

SECTION **HA**

HEATER & AIR CONDITIONING SYSTEM

A
B
C
D
E
F
G
H
HA
J
K
L
M
N
O
P

CONTENTS

PRECAUTION	3	Perform Lubricant Return Operation	22
PRECAUTIONS	3	Lubricant Adjusting Procedure for Components	
Precaution for Supplemental Restraint System (SRS) "AIR BAG" and "SEAT BELT PRE-TENSIONER"	3	Replacement Except Compressor	22
Precaution for Procedure without Cowl Top Cover.....	3	Lubricant Adjusting Procedure for Compressor	
Precautions for Removing Battery Terminal	4	Replacement	23
Precautions For Refrigerant System Service	4	PERFORMANCE TEST	25
Service Equipment	7	Inspection	25
PREPARATION	9	SYMPTOM DIAGNOSIS	27
PREPARATION	9	REFRIGERATION SYSTEM SYMPTOMS	27
Special Service Tool	9	Trouble Diagnosis For Unusual Pressure	27
Commercial Service Tool	12	Symptom Table	27
Sealant or/and Lubricant	12	NOISE	29
SYSTEM DESCRIPTION	13	Symptom Table	29
COMPONENT PARTS	13	REMOVAL AND INSTALLATION	30
Component Parts Location	13	COMPRESSOR	30
Component Description	13	Exploded View	30
SYSTEM	14	COMPRESSOR	30
System Diagram	14	COMPRESSOR : Removal and Installation	31
System Description	14	MAGNET CLUTCH	32
BASIC INSPECTION	16	MAGNET CLUTCH : Removal and Installation of Compressor Clutch	32
DIAGNOSIS AND REPAIR WORKFLOW	16	Inspection	32
Work Flow	16	COOLER PIPE AND HOSE	34
REFRIGERANT	18	Exploded View	34
Description	18	HIGH-PRESSURE FLEXIBLE HOSE	35
Leak Test	18	HIGH-PRESSURE FLEXIBLE HOSE : Removal and Installation	35
Recycle Refrigerant	20	LOW-PRESSURE FLEXIBLE HOSE	36
Charge Refrigerant	20	LOW-PRESSURE FLEXIBLE HOSE : Removal and Installation	36
LUBRICANT	22	HIGH-PRESSURE PIPE	36
Description	22		
Inspection	22		

HIGH-PRESSURE PIPE : Removal and Installation	36	EVAPORATOR PIPE ASSEMBLY	52
		EVAPORATOR PIPE ASSEMBLY : Removal and Installation	53
COOLER PIPE ASSEMBLY	37	HEATER CORE	53
COOLER PIPE ASSEMBLY : Removal and Installation	37	HEATER CORE : Removal and Installation	53
REAR COOLER PIPE 1	40	EXPANSION VALVE	54
REAR COOLER PIPE 1 : Removal and Installation	40	EXPANSION VALVE : Removal and Installation ...	54
REAR COOLER PIPE 2	42	REAR A/C UNIT	55
REAR COOLER PIPE 2 : Removal and Installation	42	Exploded View	55
CONDENSER	43	REAR A/C UNIT ASSEMBLY	56
Exploded View	43	REAR A/C UNIT ASSEMBLY : Removal and Installation	56
CONDENSER	43	EVAPORATOR	57
CONDENSER : Removal and Installation	43	EVAPORATOR : Removal and Installation	57
CONDENSER PIPE ASSEMBLY	44	EVAPORATOR PIPE ASSEMBLY	58
CONDENSER PIPE ASSEMBLY : Removal and Installation	44	EVAPORATOR PIPE ASSEMBLY : Removal and Installation	58
LIQUID TANK	44	HEATER CORE	58
LIQUID TANK : Removal and Installation	44	HEATER CORE : Removal and Installation	58
REFRIGERANT PRESSURE SENSOR	45	EXPANSION VALVE	59
REFRIGERANT PRESSURE SENSOR : Removal and Installation	45	EXPANSION VALVE : Removal and Installation ...	59
A/C UNIT ASSEMBLY	46	SERVICE DATA AND SPECIFICATIONS (SDS)	60
Exploded View	46	SERVICE DATA AND SPECIFICATIONS (SDS)	60
HEATER & COOLING UNIT ASSEMBLY	48	Compressor	60
HEATER & COOLING UNIT ASSEMBLY : Removal and Installation	48	Lubricant	60
EVAPORATOR	52	Refrigerant	60
EVAPORATOR : Removal and Installation	52	Engine Idling Speed	60
		Belt Tension	60

PRECAUTIONS

< PRECAUTION >

PRECAUTION

PRECAUTIONS

Precaution for Supplemental Restraint System (SRS) "AIR BAG" and "SEAT BELT PRE-TENSIONER"

INFOID:000000011324167

The Supplemental Restraint System such as "AIR BAG" and "SEAT BELT PRE-TENSIONER", used along with a front seat belt, helps to reduce the risk or severity of injury to the driver and front passenger for certain types of collision. This system includes seat belt switch inputs and dual stage front air bag modules. The SRS system uses the seat belt switches to determine the front air bag deployment, and may only deploy one front air bag, depending on the severity of a collision and whether the front occupants are belted or unbelted. Information necessary to service the system safely is included in the "SRS AIR BAG" and "SEAT BELT" of this Service Manual.

WARNING:

Always observe the following items for preventing accidental activation.

- To avoid rendering the SRS inoperative, which could increase the risk of personal injury or death in the event of a collision that would result in air bag inflation, all maintenance must be performed by an authorized NISSAN/INFINITI dealer.
- Improper maintenance, including incorrect removal and installation of the SRS, can lead to personal injury caused by unintentional activation of the system. For removal of Spiral Cable and Air Bag Module, see "SRS AIR BAG".
- Never use electrical test equipment on any circuit related to the SRS unless instructed to in this Service Manual. SRS wiring harnesses can be identified by yellow and/or orange harnesses or harness connectors.

PRECAUTIONS WHEN USING POWER TOOLS (AIR OR ELECTRIC) AND HAMMERS

WARNING:

Always observe the following items for preventing accidental activation.

- When working near the Air Bag Diagnosis Sensor Unit or other Air Bag System sensors with the ignition ON or engine running, never use air or electric power tools or strike near the sensor(s) with a hammer. Heavy vibration could activate the sensor(s) and deploy the air bag(s), possibly causing serious injury.
- When using air or electric power tools or hammers, always switch the ignition OFF, disconnect the battery, and wait at least 3 minutes before performing any service.

Precaution for Procedure without Cowl Top Cover

INFOID:000000011324168

When performing the procedure after removing cowl top cover, cover the lower end of windshield with urethane, etc to prevent damage to windshield.

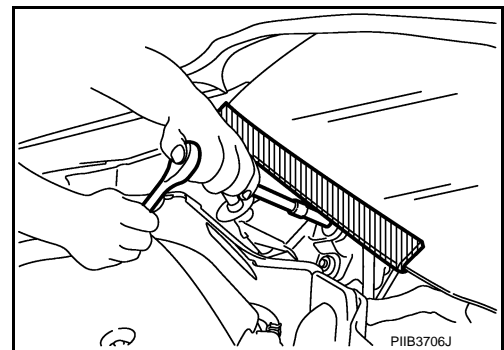

PRECAUTIONS

< PRECAUTION >

Precautions for Removing Battery Terminal

INFOID:000000011324169

- When removing the 12V battery terminal, turn OFF the ignition switch and wait at least 30 seconds.

NOTE:

ECU may be active for several tens of seconds after the ignition switch is turned OFF. If the battery terminal is removed before ECU stops, then a DTC detection error or ECU data corruption may occur.

- For vehicles with the 2-batteries, be sure to connect the main battery and the sub battery before turning ON the ignition switch.

NOTE:

If the ignition switch is turned ON with any one of the terminals of main battery and sub battery disconnected, then DTC may be detected.

- After installing the 12V battery, always check "Self Diagnosis Result" of all ECUs and erase DTC.

NOTE:

The removal of 12V battery may cause a DTC detection error.

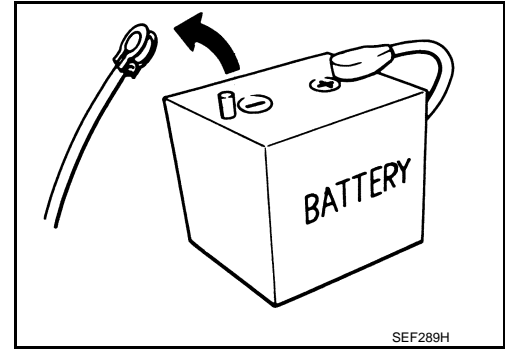

Precautions For Refrigerant System Service

INFOID:000000011324170

GENERAL REFRIGERANT PRECAUTION

WARNING:

- **Never breathe A/C refrigerant and lubricant vapor or mist. Exposure may irritate eyes, nose and throat. Remove HFC-134a (R-134a) from the A/C system, using certified service equipment meeting requirements of SAE J-2210 [HFC-134a (R-134a) recycling equipment], or J-2209 [HFC-134a (R-134a) recovery equipment]. Ventilate work area before resuming service if accidental system discharge occurs. Additional health and safety information may be obtained from refrigerant and lubricant manufacturers.**
- **Never release refrigerant into the air. Use approved recovery/recycling recharging equipment to capture the refrigerant each time an air conditioning system is discharged.**
- **Wear always eye and hand protection (goggles and gloves) when working with any refrigerant or air conditioning system.**
- **Never store or heat refrigerant containers above 52°C (126°F).**
- **Never heat a refrigerant container with an open flame; Place the bottom of the container in a warm pail of water if container warming is required.**
- **Never intentionally drop, puncture, or incinerate refrigerant containers.**
- **Keep refrigerant away from open flames: poisonous gas is produced if refrigerant burns.**
- **Refrigerant displaces oxygen, therefore be certain to work in well ventilated areas to prevent suffocation.**
- **Never pressure test or leakage test HFC-134a (R-134a) service equipment and/or vehicle air conditioning systems with compressed air during repair. Some mixtures of air and HFC-134a (R-134a) have been shown to be combustible at elevated pressures. These mixtures, if ignited, may cause injury or property damage. Additional health and safety information may be obtained from refrigerant manufacturers.**

WORKING WITH HFC-134a (R-134a)

CAUTION:

- **CFC-12 (R-12) refrigerant and HFC-134a (R-134a) refrigerant are not compatible. Compressor malfunction is likely to occur if the refrigerants are mixed, refer to "CONTAMINATED REFRIGERANT" below. To determine the purity of HFC-134a (R-134a) in the vehicle and recovery tank, use Refrigerant recovery/recycling recharging equipment and Refrigerant Identifier.**
- **Use only specified lubricant for the HFC-134a (R-134a) A/C system and HFC-134a (R-134a) components. Compressor malfunction is likely to occur if lubricant other than that specified is used.**
- **The specified HFC-134a (R-134a) lubricant rapidly absorbs moisture from the atmosphere. The following handling precautions must be observed:**
 - **Cap (seal) immediately the component to minimize the entry of moisture from the atmosphere when removing refrigerant components from a vehicle.**
 - **Never remove the caps (unseal) until just before connecting the components when installing refrigerant components to a vehicle. Connect all refrigerant loop components as quickly as possible to minimize the entry of moisture into system.**

PRECAUTIONS

< PRECAUTION >

- Use only the specified lubricant from a sealed container. Reseal immediately containers of lubricant. Lubricant becomes moisture saturated and should not be used without proper sealing.
- Never allow lubricant to come in contact with styrene foam parts. Damage may result.

CONTAMINATED REFRIGERANT

Take appropriate steps shown below if a refrigerant other than pure HFC-134a (R-134a) is identified in a vehicle:

- Explain to the customer that environmental regulations prohibit the release of contaminated refrigerant into the atmosphere.
- Explain that recovery of the contaminated refrigerant could damage service equipment and refrigerant supply.
- Suggest the customer return the vehicle to the location of previous service where the contamination may have occurred.
- In case of repairing, recover the refrigerant using only **dedicated equipment and containers. Never recover contaminated refrigerant into the existing service equipment.** Contact a local refrigerant product retailer for available service if the facility does not have dedicated recovery equipment. This refrigerant must be disposed of in accordance with all federal and local regulations. In addition, replacement of all refrigerant system components on the vehicle is recommended.
- The air conditioner warranty is void if the vehicle is within the warranty period. Please contact Nissan Customer Affairs for further assistance.

REFRIGERANT CONNECTION

A new type refrigerant connection has been introduced to all refrigerant lines except the following location.

- Expansion valve to evaporator
- Refrigerant pressure sensor to liquid tank

WARNING:

Check that all refrigerant is discharged into the recycling equipment and the pressure in the system is less than atmospheric pressure. Then gradually loosen the discharge side hose fitting and remove it.

CAUTION:

Observe the following when replacing or cleaning refrigerant cycle components.

- Store it in the same way at it is when mounted on the car when the compressor is removed. Failure to do so will cause lubricant to enter the low-pressure chamber.
- Use always a torque wrench and a back-up wrench when connecting tubes.
- Plug immediately all openings to prevent entry of dust and moisture after disconnecting tubes.
- Connect the pipes at the final stage of the operation when installing an air conditioner in the vehicle. Never remove the seal caps of pipes and other components until just before required for connection.
- Allow components stored in cool areas to warm to working area temperature before removing seal caps. This prevents condensation from forming inside A/C components.
- Remove thoroughly moisture from the refrigeration system before charging the refrigerant.
- Replace always used O-rings.
- Apply lubricant to circle of the O-rings shown in illustration when connecting tube. Be careful not to apply lubricant to threaded portion.
- O-ring must be closely attached to the groove portion of tube.
- Be careful not to damage O-ring and tube when replacing the O-ring.
- Connect tube until a click can be heard. Then tighten the nut or bolt by hand. Check that the O-ring is installed to tube correctly.

PRECAUTIONS

< PRECAUTION >

- Perform leakage test and make sure that there is no leakage from connections after connecting line. Disconnect that line and replace the O-ring when the refrigerant leaking point is found. Then tighten connections of seal seat to the specified torque.

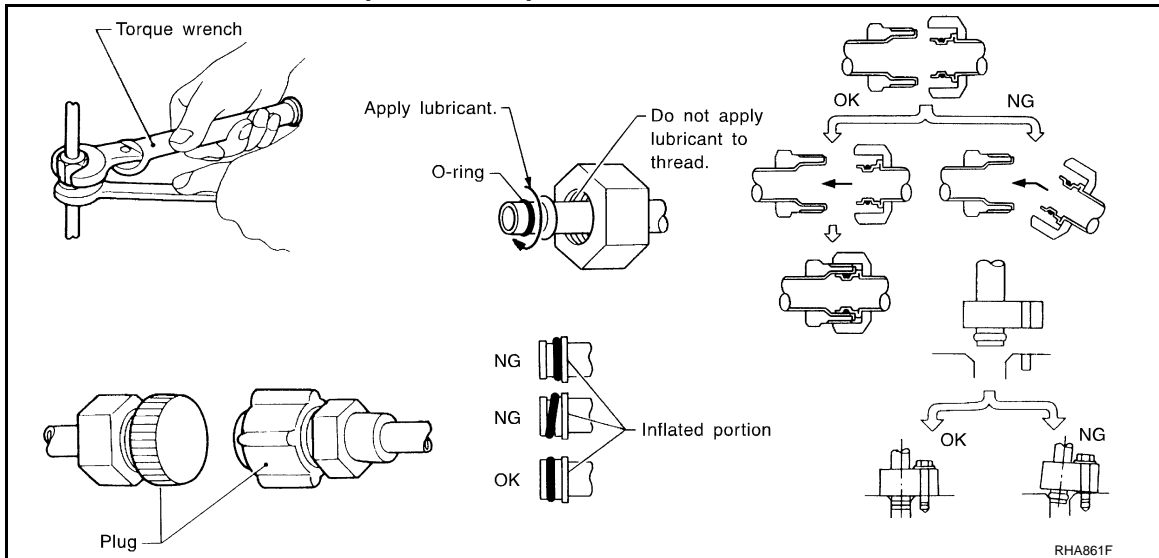

COMPRESSOR

CAUTION:

- Plug all openings to prevent moisture and foreign matter from entering.
- Store it in the same way at it is when mounted on the car when the compressor is removed.
- Follow "Maintenance of Lubricant Quantity in Compressor" exactly when replacing or repairing compressor. Refer to [HA-22, "Description"](#).
- Keep friction surfaces between clutch and pulley clean. Wipe it off by using a clean waste cloth moistened with thinner if the surface is contaminated with lubricant.
- Turn the compressor shaft by hand more than five turns in both directions after compressor service operation. This distributes equally lubricant inside the compressor. Let the engine idle and operate the compressor for one hour after the compressor is installed.
- Apply voltage to the new one and check for normal operation after replacing the compressor magnet clutch.

LEAK DETECTION DYE

CAUTION:

- The A/C system contains a fluorescent leak detection dye used for locating refrigerant leakages. An ultraviolet (UV) lamp is required to illuminate the dye when inspecting for leakages.
- Wear always fluorescence enhancing UV safety goggles to protect eyes and enhance the visibility of the fluorescent dye.
- The fluorescent dye leak detector is not a replacement for an electrical leak detector (SST: J-41995). The fluorescent dye leak detector should be used in conjunction with an electrical leak detector (SST: J-41995) to pin-point refrigerant leakages.
- Read and follow all manufacturer's operating instructions and precautions prior to performing the work for the purpose of safety and customer's satisfaction.
- A compressor shaft seal should not necessarily be repaired because of dye seepage. The compressor shaft seal should only be repaired after confirming the leakage with an electrical leak detector (SST: J-41995).
- Remove always any remaining dye from the leakage area after repairs are completed to avoid a misdiagnosis during a future service.
- Never allow dye to come into contact with painted body panels or interior components. Clean immediately with the approved dye cleaner if dye is spilled. Fluorescent dye left on a surface for an extended period of time cannot be removed.
- Never spray the fluorescent dye cleaning agent on hot surfaces (engine exhaust manifold, etc.).
- Never use more than one refrigerant dye bottle [1/4 ounce (7.4 cc)] per A/C system.
- Leak detection dyes for HFC-134a (R-134a) and CFC-12 (R-12) A/C systems are different. Never use HFC-134a (R-134a) leak detection dye in CFC-12 (R-12) A/C system, or CFC-12 (R-12) leak detection dye in HFC-134a (R-134a) A/C system, or A/C system damage may result.
- The fluorescent properties of the dye remains for three or more years unless a compressor malfunction occurs.

PRECAUTIONS

< PRECAUTION >

NOTE:

- Identification
- Vehicles with factory installed fluorescent dye have a green label.
- Vehicles without factory installed fluorescent dye have a blue label.

Service Equipment

INFOID:000000011324171

RECOVERY/RECYCLING RECHARGING EQUIPMENT

Be certain to follow the manufacturer's instructions for machine operation and machine maintenance. Never introduce any refrigerant other than that specified into the machine.

ELECTRICAL LEAK DETECTOR

Be certain to follow the manufacturer's instructions for tester operation and tester maintenance.

VACUUM PUMP

The lubricant contained inside the vacuum pump is not compatible with the specified lubricant for HFC-134a (R-134a) A/C systems. The vent side of the vacuum pump is exposed to atmospheric pressure. So the vacuum pump lubricant may migrate out of the pump into the service hose. This is possible when the pump is switched OFF after evacuation (vacuuming) and hose is connected to it. To prevent this migration, use a manual valve placed near the hose-to-pump connection, as per the following.

- Vacuum pumps usually have a manual isolator valve as part of the pump. Close this valve to isolate the service hose from the pump.
- Use a hose equipped with a manual shut-off valve near the pump end for pumps without an isolator. Close the valve to isolate the hose from the pump.
- Disconnect the hose from the pump if the hose has an automatic shut-off valve. As long as the hose is connected, the valve is open and lubricating oil may migrate.

Some one-way valves open when vacuum is applied and close under no vacuum condition. Such valves may restrict the pump's ability to pull a deep vacuum and are not recommended.

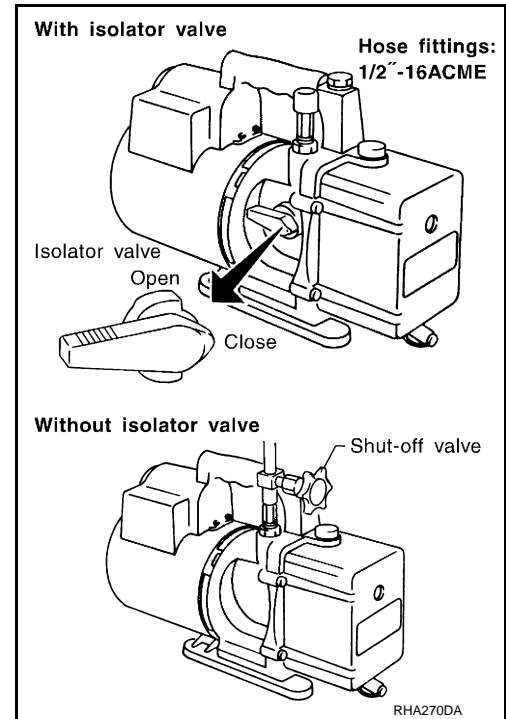

MANIFOLD GAUGE SET

Be certain that the gauge face indicates HFC-134a or R-134a. Be sure the gauge set has 1/2"-16 ACME threaded connections for service hoses. Confirm the set has been used only with refrigerant HFC-134a (R-134a) and specified lubricants.

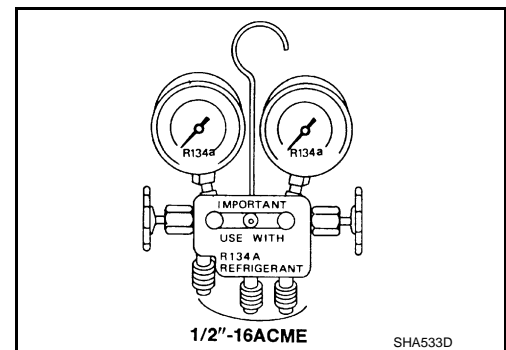

SERVICE HOSES

PRECAUTIONS

< PRECAUTION >

Be certain that the service hoses display the markings described (colored hose with black stripe). All hoses must equip positive shut-off devices (either manual or automatic) near the end of the hoses opposite to the manifold gauge.

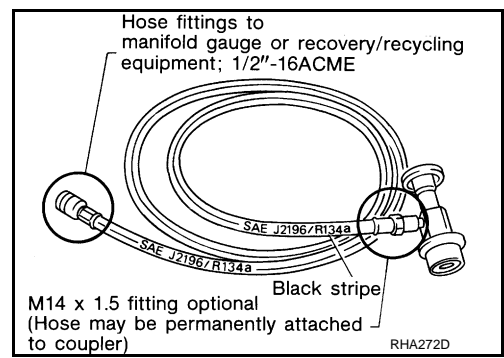

SERVICE COUPLERS

Never attempt to connect HFC-134a (R-134a) service couplers to the CFC-12 (R-12) A/C system. The HFC-134a (R-134a) couplers do not properly connect to the CFC-12 (R-12) system. However, if an improper connection is attempted, discharging and contamination may occur.

Shut-off valve rotation	A/C service valve
Clockwise	Open
Counterclockwise	Close

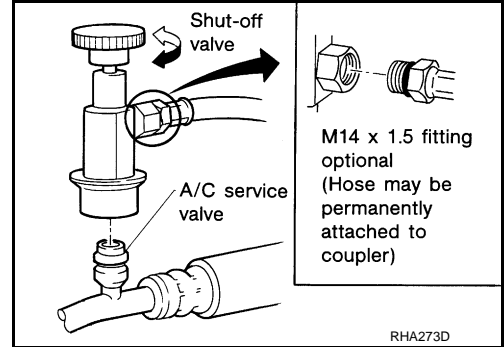

REFRIGERANT WEIGHT SCALE

Verify that no refrigerant other than HFC-134a (R-134a) and specified lubricants have been used with the scale. The hose fitting must be 1/2"-16 ACME if the scale controls refrigerant flow electronically.

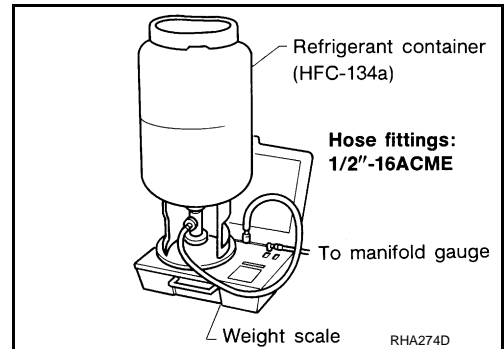

CHARGING CYLINDER

Using a charging cylinder is not recommended. Refrigerant may be vented into air from cylinder's top valve when filling the cylinder with refrigerant. Also, the accuracy of the cylinder is generally less than that of an electronic scale or of quality recycle/recharge equipment.

PREPARATION

< PREPARATION >

PREPARATION

PREPARATION



Special Service Tool

INFOID:000000011324172

The actual shapes of Kent-Moore tools may differ from those of special service tools illustrated here.



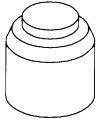

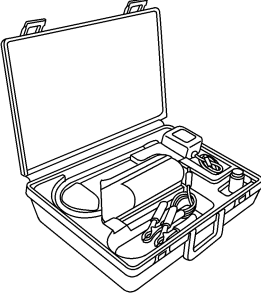
HFC-134a (R-134a) Service Tool and Equipment

- Never mix HFC-134a (R-134a) refrigerant and/or its specified lubricant with CFC-12 (R-12) refrigerant and/or its lubricant.
- Separate and non-interchangeable service equipment must be used for handling each type of refrigerant/lubricant.
- Refrigerant container fittings, service hose fittings and service equipment fittings (equipment that handles refrigerant and/or lubricant) are different between CFC-12 (R-12) and HFC-134a (R-134a). This is to avoid mixed use of the refrigerants/lubricant.
- Never use adapters that convert one size fitting to another. Refrigerant/lubricant contamination occurs and compressor malfunction may result.

Tool number (Kent-Moore No.) Tool name	Description
KV99106200 (J-41260) Pulley installer  S-NT235	Installing pulley
(ACR2005-NI) ACR5 A/C Service Center  WJIA0293E	Function: Refrigerant recovery, recycling and recharging
(J-41995) Electrical leak detector  AHA281A	Power supply: DC 12 V (Battery terminal)

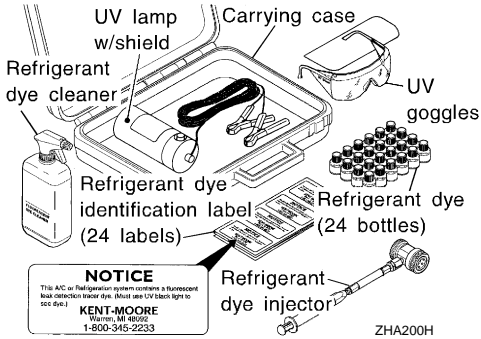
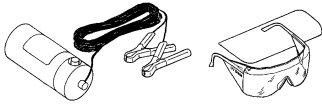
PREPARATION

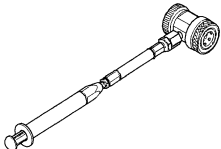
< PREPARATION >

Tool number (Kent-Moore No.) Tool name	Description
<p>(J-43926) Refrigerant dye leak detection kit Kit includes: (J-42220) UV lamp and UV safety goggles (J-41459) HFC-134a (R-134a) dye injector Use with J-41447, 1/4 ounce bottle (J-41447) HFC-134a (R-134a) fluorescent leak detection dye (Box of 24, 1/4 ounce bottles) (J-43872) Refrigerant dye cleaner</p>	 <p style="text-align: right;">Power supply: DC 12 V (Battery terminal)</p>
<p>(J-42220) UV lamp and UV safety goggles</p>	 <p style="text-align: center;">SHA438F</p> <p style="text-align: right;">Power supply: DC 12 V (Battery terminal) For checking refrigerant leakage when fluorescent dye is equipped in A/C system Includes: UV lamp and UV safety goggles</p>
<p>(J-41447) HFC-134a (R-134a) fluorescent leak detection dye (Box of 24, 1/4 ounce bottles)</p>	 <p style="text-align: center;">Refrigerant dye (24 bottles)</p> <p style="text-align: center;">SHA439F</p> <p style="text-align: right;">Application: For HFC-134a (R-134a) PAG oil Container: 1/4 ounce (7.4 cc) bottle (Includes self-adhesive dye identification labels for affixing to vehicle after charging system with dye.)</p>
<p>(J-41459) HFC-134a (R-134a) dye injector Use with J-41447, 1/4 ounce bottle</p>	 <p style="text-align: center;">SHA440F</p> <p style="text-align: right;">For injecting 1/4 ounce of fluorescent leak detection dye into A/C system</p>
<p>(J-43872) Refrigerant dye cleaner</p>	 <p style="text-align: center;">SHA441F</p> <p style="text-align: right;">For cleaning dye spills</p>

PREPARATION

< PREPARATION >

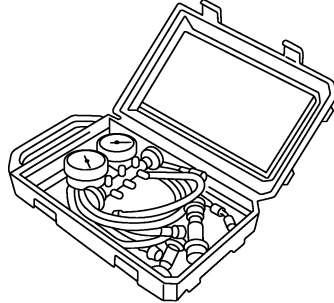
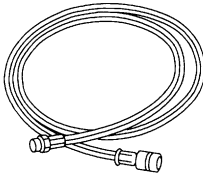
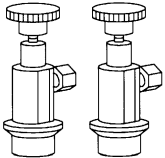
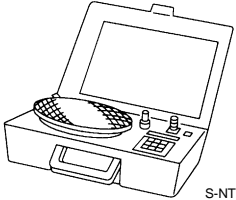
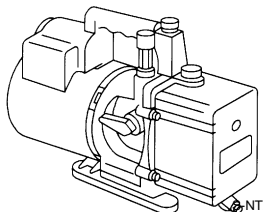
Tool number (Kent-Moore No.) Tool name	Description	A
<p>(J-39183) Manifold gauge set (with hoses and couplers)</p>  <p style="text-align: right; font-size: small;">RJIA0196E</p>	<p>Identification:</p> <ul style="list-style-type: none"> The gauge face indicates HFC-134a (R-134a). <p>Fitting size: Thread size</p> <ul style="list-style-type: none"> 1/2" -16 ACME 	B C D
<p>Service hoses</p> <ul style="list-style-type: none"> High-pressure side hose (J-39501-72) Low-pressure side hose (J-39502-72) Utility hose (J-39476-72)  <p style="text-align: right; font-size: small;">S-NT201</p>	<p>Hose color:</p> <ul style="list-style-type: none"> Low-pressure side hose: Blue with black stripe High-pressure side hose: Red with black stripe Utility hose: Yellow with black stripe or green with black stripe <p>Hose fitting to gauge:</p> <ul style="list-style-type: none"> 1/2" -16 ACME 	E F G
<p>Service couplers</p> <ul style="list-style-type: none"> High-pressure side coupler (J-39500-20) Low-pressure side coupler (J-39500-24)  <p style="text-align: right; font-size: small;">S-NT202</p>	<p>Hose fitting to service hose: M14 x 1.5 fitting is optional or permanently attached.</p>	H HA
<p>(J-39650) Refrigerant weight scale</p>  <p style="text-align: right; font-size: small;">S-NT200</p>	<p>For measuring of refrigerant</p> <p>Fitting size: Thread size</p> <p>1/2" -16 ACME</p>	J K L
<p>(J-39649) Vacuum pump (Including the isolator valve)</p>  <p style="text-align: right; font-size: small;">S-NT203</p>	<p>Capacity:</p> <ul style="list-style-type: none"> Air displacement: 4 CFM Micron rating: 20 microns Oil capacity: 482 g (17 oz) <p>Fitting size: Thread size</p> <ul style="list-style-type: none"> 1/2" -16 ACME 	M N O P

PREPARATION

< PREPARATION >

Commercial Service Tool

INFOID:000000011324173

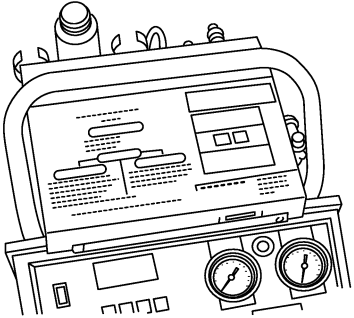
Tool name	Description
<p>Refrigerant identifier equipment</p> <div style="text-align: center;">  <p style="font-size: small;">RJIA0197E</p> </div>	<p>Checking for refrigerant purity and system contamination</p>

Sealant or/and Lubricant

INFOID:000000011324174

HFC-134a (R-134a) Service Tool and Equipment

- Never mix HFC-134a (R-134a) refrigerant and/or its specified lubricant with CFC-12 (R-12) refrigerant and/or its lubricant.
- Separate and non-interchangeable service equipment must be used for handling each type of refrigerant/lubricant.
- Refrigerant container fittings, service hose fittings and service equipment fittings (equipment which handles refrigerant and/or lubricant) are different between CFC-12 (R-12) and HFC-134a (R-134a). This is to avoid mixed use of the refrigerants/lubricant.
- Never use adapters that convert one size fitting to another: refrigerant/lubricant contamination occurs and compressor malfunction may result.

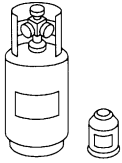
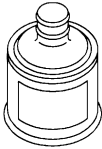
Tool name	Description
<p>HFC-134a (R-134a) refrigerant</p> <div style="text-align: center;">  <p style="font-size: small;">S-NT196</p> </div>	<p>Container color: Light blue Container marking: HFC-134a (R-134a) Fitting size: Thread size</p> <ul style="list-style-type: none"> • Large container 1/2"-16 ACME
<p>A/C System Oil Type S (DH-PS)</p> <div style="text-align: center;">  <p style="font-size: small;">JMIIA1759ZZ</p> </div>	<p>Type: Polyalkylene glycol oil (PAG), type S (DH-PS) Application: HFC-134a (R-134a) swash plate compressors Capacity: 40 mℓ (1.4 US fl oz, 1.4 Imp fl oz)</p>

COMPONENT PARTS

< SYSTEM DESCRIPTION >

SYSTEM DESCRIPTION

COMPONENT PARTS

Component Parts Location

INFOID:0000000011324175

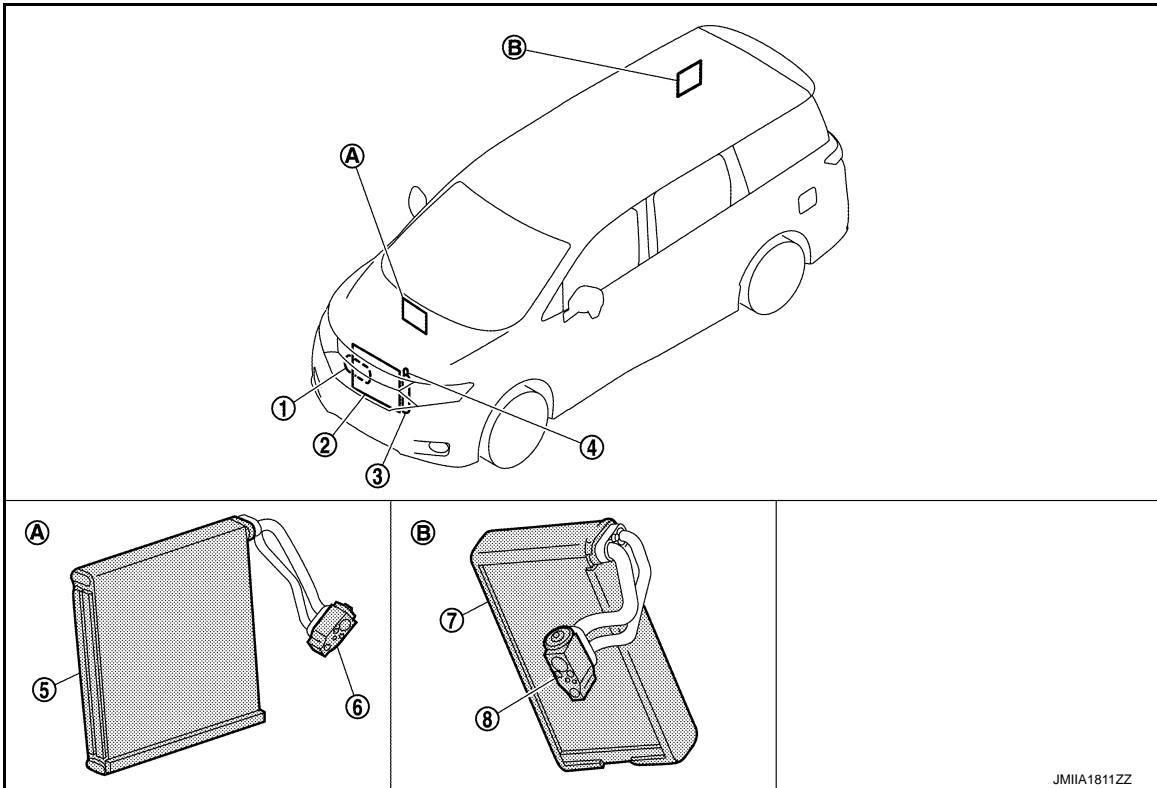

- | | | |
|--|------------------------------------|--------------------|
| 1. Compressor | 2. Condenser | 3. Liquid tank |
| 4. Refrigerant pressure sensor | 5. Evaporator | 6. Expansion valve |
| 7. Evaporator | 8. Expansion valve | |
| A. Built-in heater & cooling unit assembly | B. Built-in rear A/C unit assembly | |

Component Description

INFOID:0000000011324176

Component	Description
Evaporator	The mist form liquid refrigerant transforms to gas by evaporation by the air conveyed from blower motor. The air is cooled by the heat by evaporation.
Condenser	Cools refrigerant discharged from compressor, and transforms it to liquid refrigerant.
Compressor	Intakes, compresses, and discharges refrigerant, to circulate refrigerant inside the refrigerant cycle.
Refrigerant pressure sensor	Refer to HAC-13, "Refrigerant Pressure Sensor" .
Liquid tank	Eliminates foreign matter in refrigerant, and stores temporarily liquid refrigerant.
Expansion valve	Transforms high-pressure liquid refrigerant to mist form low-pressure liquid refrigerant by drawing function.

SYSTEM

< SYSTEM DESCRIPTION >

SYSTEM

System Diagram

INFOID:000000011324177

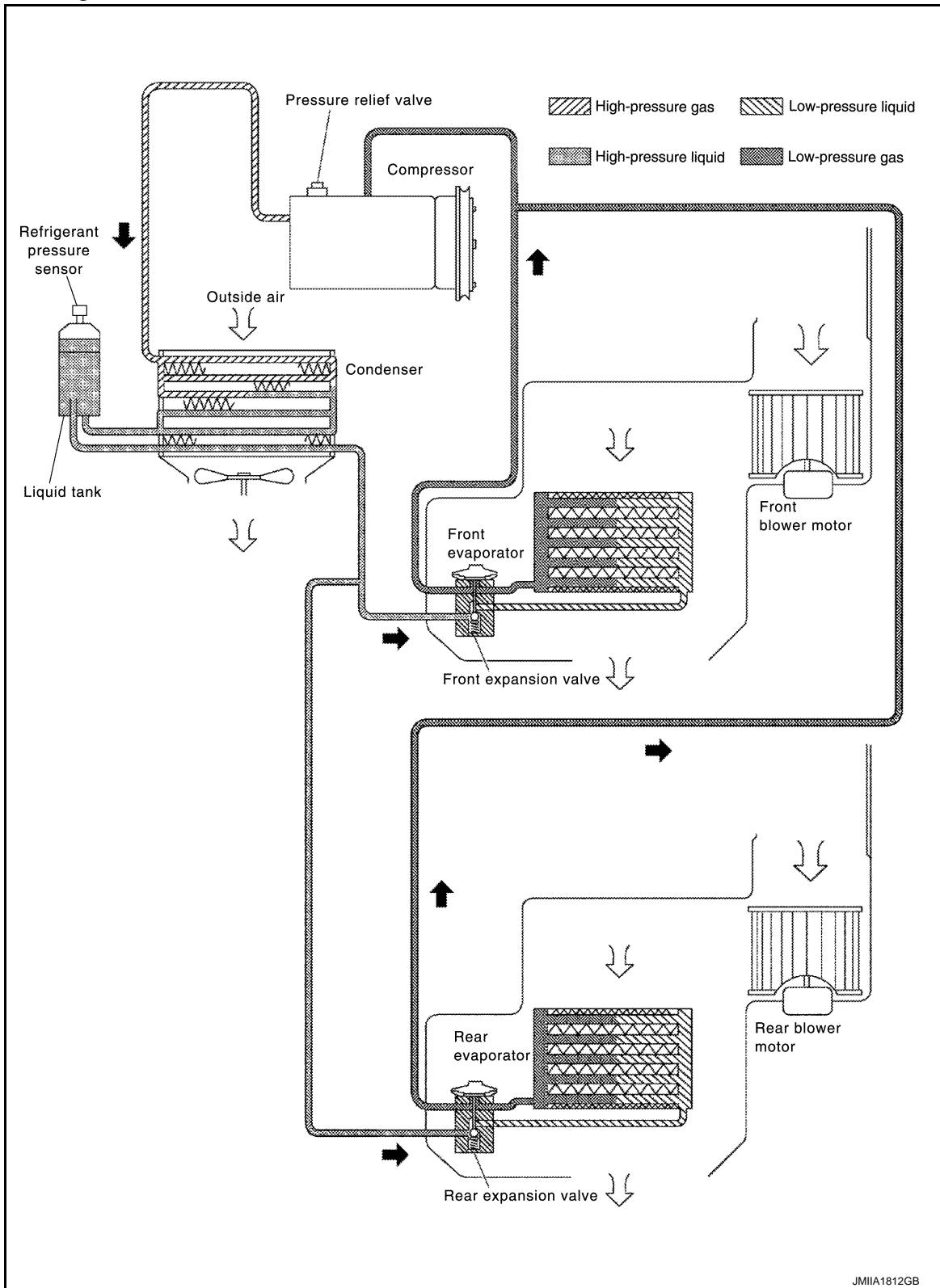

System Description

INFOID:000000011324178

REFRIGERANT CYCLE

Refrigerant Flow

Revision: 2014 August

SYSTEM

< SYSTEM DESCRIPTION >

The refrigerant from the compressor, flows the condenser with liquid tank, the evaporator, and returns to the compressor. The refrigerant evaporation in the evaporator is controlled by an expansion valve.

A

Freeze Protection

When evaporator fin temperature is low, compressor stops so that freeze of evaporator can be prevented.

- Refer to [HAC-19. "FRONT AUTOMATIC AIR CONDITIONING SYSTEM : Compressor Control"](#). (Automatic air conditioning)
- Refer to [HAC-163. "FRONT MANUAL AIR CONDITIONING SYSTEM : Compressor Control"](#). (Manual air conditioning)

B

C

REFRIGERANT SYSTEM PROTECTION

Refrigerant Pressure Sensor

- The refrigerant system is protected against excessively high- or low-pressures by the refrigerant pressure sensor, installed at the upper liquid tank. The refrigerant pressure sensor detects the pressure inside the refrigerant line and sends the voltage signal to the ECM if the system pressure rises above, or falls below the specifications.
- ECM turns the A/C relay to OFF and stops the compressor when the high-pressure side detected by refrigerant pressure sensor is following conditions;
 - Approximately 3,120 kPa (31.8 kg/cm², 452 psi) or more (Engine speed is less than 1,500 rpm.)
 - Approximately 2,740 kPa (27.9 kg/cm², 397 psi) or more (Engine speed is 1,500 rpm or more.)
 - Approximately 140 kPa (1.4 kg/cm², 20 psi) or less

D

E

F

Pressure Relief Valve

The refrigerant system is also protected by a pressure relief valve, located in the rear head of the compressor. The release port on the pressure relief valve automatically opens and releases refrigerant into the atmosphere when the pressure of refrigerant in the system increases to an unusual level [more than 3,800 kPa (38.8 kg/cm², 551 psi)].

G

H

HA

J

K

L

M

N

O

P

DIAGNOSIS AND REPAIR WORKFLOW

< BASIC INSPECTION >

BASIC INSPECTION

DIAGNOSIS AND REPAIR WORKFLOW

Work Flow

INFOID:000000011324179

OVERALL SEQUENCE

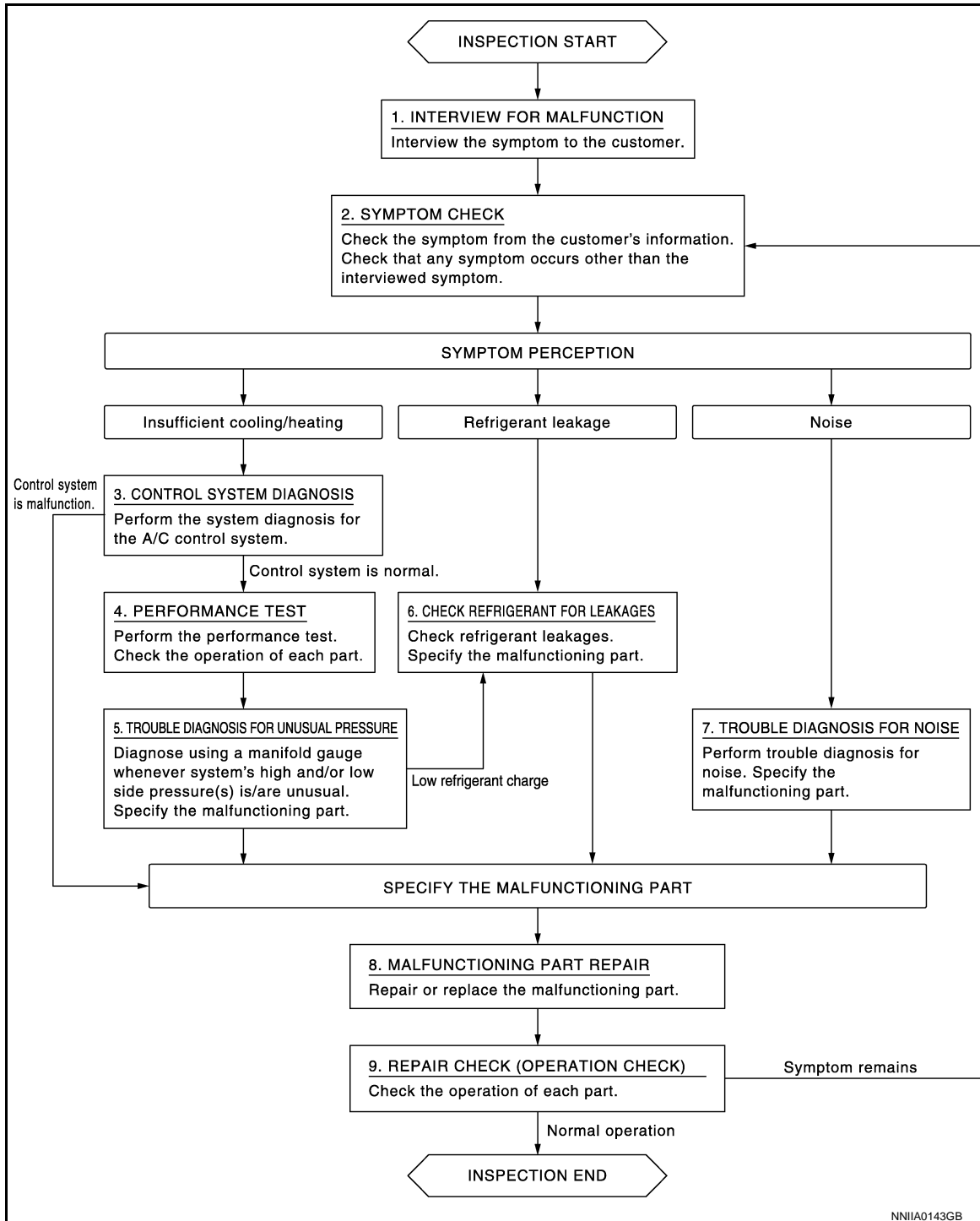

DETAILED FLOW

1. INTERVIEW FOR MALFUNCTION

Interview the symptom to the customer.

DIAGNOSIS AND REPAIR WORKFLOW

< BASIC INSPECTION >

>> GO TO 2.

2. SYMPTOM CHECK

Check the symptom from the customer's information. Check that any symptom occurs other than the interviewed symptom.

Insufficient cooling/heating>>GO TO 3.

Refrigerant leakage>>GO TO 6.

Noise >> GO TO 7.

3. CONTROL SYSTEM DIAGNOSIS

Perform the system diagnosis for the A/C control system.

- Refer to [HAC-73, "Work Flow"](#). (Automatic air conditioning)
- Refer to [HAC-191, "Work Flow"](#). (Manual air conditioning)

Is A/C control system normal?

YES >> GO TO 4.

NO >> GO TO 8.

4. PERFORMANCE TEST

Perform the performance test. Check the operation of each part. Refer to [HA-25, "Inspection"](#).

>> GO TO 5.

5. TROUBLE DIAGNOSIS FOR UNUSUAL PRESSURE

Diagnose using a manifold gauge whenever system's high and/or low side pressure(s) is/are unusual. Specify the malfunctioning part. Refer to [HA-27, "Symptom Table"](#).

Low refrigerant charge>>GO TO 6.

Except above>>GO TO 8.

6. CHECK REFRIGERANT FOR LEAKAGES

Check refrigerant for leakages. Specify the malfunctioning part. Refer to [HA-18, "Leak Test"](#).

>> GO TO 8.

7. TROUBLE DIAGNOSIS FOR NOISE

Perform trouble diagnosis for noise. Specify the malfunctioning part. Refer to [HA-29, "Symptom Table"](#).

>> GO TO 8.

8. MALFUNCTION PART REPAIR

Repair or replace the malfunctioning part.

>> GO TO 9.

9. REPAIR CHECK (OPERATION CHECK)

Check the operation of each part.

Does it operate normally?

YES >> INSPECTION END

NO >> GO TO 2.

A
B
C
D
E
F
G
H
HA
J
K
L
M
N
O
P

REFRIGERANT

< BASIC INSPECTION >

REFRIGERANT

Description

INFOID:000000011324180

CONNECTION OF SERVICE TOOLS AND EQUIPMENT

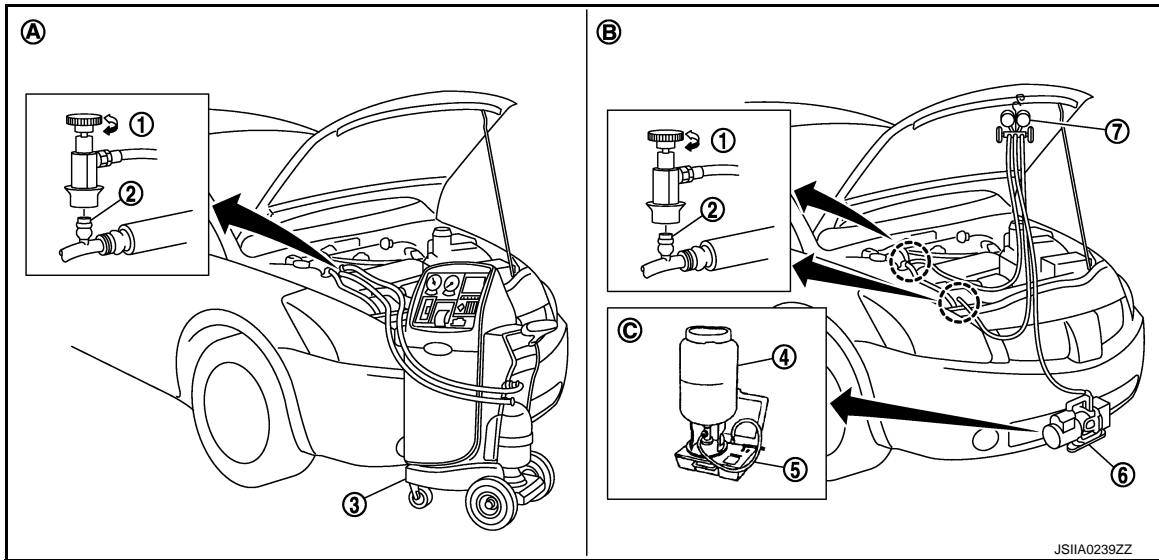

- | | | |
|-------------------------------------|---------------------------|--|
| 1. Shut-off valve | 2. A/C service valve | 3. Recovery/recycling/recharging equipment |
| 4. Refrigerant container (HFC-134a) | 5. Weight scale (J-39650) | 6. Vacuum pump (J-39649) |
| 7. Manifold gauge set (J-39183) | | |
| A. Preferred (best) method | B. Alternative method | C. For charging |

Leak Test

INFOID:000000011324181

CHECK REFRIGERANT LEAKAGE USING FLUORESCENT LEAK DETECTION DYE

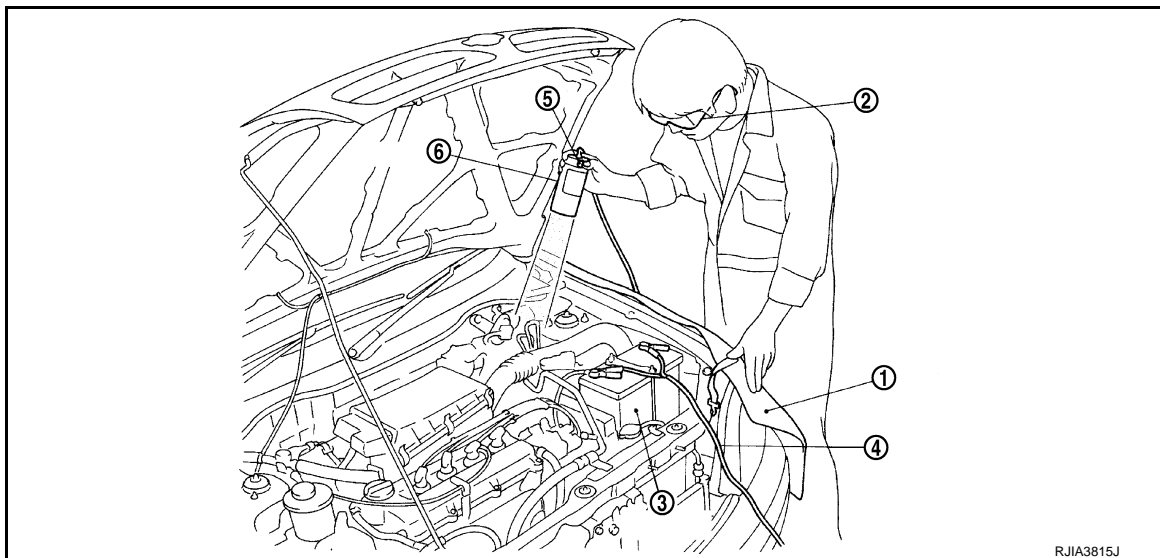

1. Install a fender cover (1).
2. Wear UV safety goggles (2) provided with refrigerant dye leak detection kit.
3. Connect power cable (4) of UV lamp (6) to positive and negative terminals of the battery (3).
4. Press UV lamp switch (5) and check A/C system for refrigerant leakage. (Where refrigerant leakage occurs, fluorescent leak detection dye appears in green color.)

WARNING:

REFRIGERANT

< BASIC INSPECTION >

Never look directly into UV lamp light source.

NOTE:

- For continuous operating time of UV lamp, follow the manufacturer operating instructions.
- Illuminate piping joints from different angles using UV lamp and check that there is no leakage.
- Use a mirror in area that is difficult to see to check refrigerant leakage.
- Refrigerant leakage from evaporator can be detected by soaking cotton swab or a similar material with drain hose water and illuminating it using UV lamp.
- Dust, dirt, and packing materials adhesive used for condenser, evaporator, and other locations may fluoresce. Be careful not to misidentify leakage.

5. Repair or replace parts where refrigerant leakage occurs and wipe off fluorescent leak detection dye.

NOTE:

Completely wipe off fluorescent leak detection dye from gaps between parts, screw threads, and others using a cotton swab or similar materials.

6. Use a UV lamp to check that no fluorescent leak detection dye remains after finishing work.

WARNING:

Never look directly into UV lamp light source.

NOTE:

- For continuous operating time of UV lamp, follow the manufacturer operating instructions.
- Dust, dirt, and packing materials adhesive used for condenser, evaporator, and other locations may fluoresce. Be careful not to misidentify leakage.

CHECK REFRIGERANT LEAKAGE USING ELECTRICAL LEAK DETECTOR

WARNING:

Never check refrigerant leakage while the engine is running.

CAUTION:

Be careful of the following items so that inaccurate checks or misidentifications are avoided.

- **Never allow refrigerant vapor, shop chemical vapors, cigarette smoke, or others around the vehicle.**
- **Always check refrigerant leakage in a low air flow environment so that refrigerant may not disperse when leakage occurs.**

1. Stop the engine.
2. Connect recovery/recycling/recharging equipment or manifold gauge set to A/C service valve.
3. Check that A/C refrigerant pressure is 345 kPa (3.52 kg/cm², 50 psi) or more when temperature is 16°C (61°F) or more. When pressure is lower than the specified value, recycle refrigerant completely and fill refrigerant to the specified level.

NOTE:

Leakages may not be detected if A/C refrigerant pressure is 345 kPa (3.52 kg/cm², 50 psi) or less when temperature is less than 16°C (61°F).

4. Clean area where refrigerant leakage check is performed, and check refrigerant leakage along all surfaces of pipe connections and A/C system components using electrical leak detector probe.

CAUTION:

- **Continue checking when a leakage is found. Always continue and complete checking along all pipe connections and A/C system components for additional leakage.**
- **When a leakage is detected, clean leakage area using compressed air and check again.**
- **When checking leakage of cooling unit inside, always clean inside of drain hose so that the probe surface may not be exposed to water or dirt.**

NOTE:

- Always check leakage starting from high-pressure side and continue to low-pressure side.
- When checking leakage of cooling unit inside, operate blower fan motor for 15 minutes or more at the maximum fan speed while the engine is stopped, and then insert electrical leak detector probe into drain hose and hold for 10 minutes or more.
- When disconnecting shut-off valve that is connected to A/C service valve, always evacuate remaining refrigerant so that misidentification can be avoided.

5. Repair or replace parts where refrigerant leakage is detected. (Leakage is detected but leakage area is unknown. GO TO 6.)
6. Start the engine and set A/C control in the following conditions.
 - A/C switch ON
 - Air flow: VENT (ventilation)
 - Intake door position: Recirculation

A

B

C

D

E

F

G

H

HA

J

K

L

M

N

O

P

REFRIGERANT

< BASIC INSPECTION >

- Temperature setting: Full cold
 - Fan (blower) speed: Maximum speed set
7. Run the engine at approximately 1,500 rpm for 2 minutes or more.
 8. Stop the engine. Check again for refrigerant leakage. GO TO 4.

WARNING:

Be careful not to get burned when the engine is hot.

NOTE:

- Start refrigerant leakage check immediately after the engine is stopped.
- When refrigerant circulation is stopped, pressure on the low-pressure side rises gradually, and after this, pressure on the high-pressure side falls gradually.
- The higher the pressure is, the easier it is to find the refrigerant leakage.

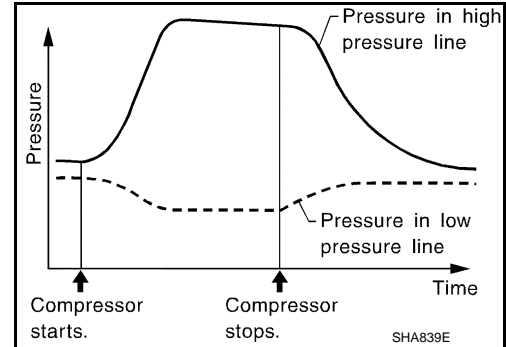

Recycle Refrigerant

INFOID:0000000011324182

WARNING:

- Always use HFC-134a for A/C refrigerant. If CFC-12 is accidentally charged, compressor is damaged due to insufficient lubrication.
 - Always observe and follow precautions described on refrigerant container. Incorrect handling may result in an explosion of refrigerant container, frostbite, or the loss of eyesight.
 - Never breathe A/C refrigerant and lubricant vapor or mist. Exposure may irritate eyes, nose, or throat.
 - Never allow HFC-134a to be exposed to an open flame or others because it generates poisonous gas when in contact with high temperature objects. Keep workshop well ventilated.
1. Perform lubricant return operation. Refer to [HA-22, "Perform Lubricant Return Operation"](#). (If refrigerant or lubricant leakage is detected in a large amount, omit this step, and then GO TO 2.)

CAUTION:

Never perform lubricant return operation if a large amount of refrigerant or lubricant leakage is detected.

2. Check gauge pressure readings of recovery/recycling/recharging equipment. When remaining pressure exists, recycle refrigerant from high-pressure hose and low-pressure hose.

NOTE:

Follow manufacturer instructions for the handling or maintenance of the equipment. Never fill the equipment with non-specified refrigerant.

3. Remove A/C service valve cap from the vehicle.
4. Connect recovery/recycling/recharging equipment to A/C service valve.
5. Operate recovery/recycling/recharging equipment, and recycle refrigerant from the vehicle.
6. Evacuate air for 10 minutes or more to remove any remaining refrigerant integrated to compressor lubricant, etc.
7. Refrigerant recycle operation is complete.

Charge Refrigerant

INFOID:0000000011324183

WARNING:

- Always use HFC-134a for A/C refrigerant. If CFC-12 is accidentally charged, compressor is damaged due to insufficient lubrication.
 - Always observe and follow precautions described on refrigerant container. Incorrect handling may result in an explosion of refrigerant container, frostbite, or the loss of eyesight.
 - Never breathe A/C refrigerant and lubricant vapor or mist. Exposure may irritate eyes, nose, or throat.
 - Never allow HFC-134a to be exposed to an open flame or others because it generates poisonous gas when in contact with high temperature objects. Keep workshop well ventilated.
1. Connect recovery/recycling/recharging equipment to the A/C service valve.

REFRIGERANT

< BASIC INSPECTION >

2. Operate recovery/recycling/recharging equipment, and evacuate air from A/C system for 25 minutes or more.
CAUTION:
Evacuate air for 15 minutes or more if the parts are replaced.
3. Check the airtightness of A/C system for 25 minutes or more. If pressure rises more than the specified level, charge A/C system with approximately 200 g (0.4 lb) refrigerant and check that there is no refrigerant leakage. Refer to [HA-18. "Leak Test"](#).
CAUTION:
Check the airtightness for 15 minutes or more if the parts are replaced.
4. If parts other than compressor are replaced, fill compressor lubricant according to parts that are replaced.
5. Charge the specified amount of refrigerant to A/C system.
6. Check that A/C system operates normally.
7. Disconnect recovery/recycling/recharging equipment. (Collect the refrigerant from the high-pressure hose and low-pressure hose of recovery/recycling/recharging equipment.)
8. Install A/C service valve cap.
9. Refrigerant charge is complete.

A

B

C

D

E

F

G

H

HA

J

K

L

M

N

O

P

LUBRICANT

< BASIC INSPECTION >

LUBRICANT

Description

INFOID:000000011324184

MAINTENANCE OF LUBRICANT LEVEL

The compressor lubricant is circulating in the system together with the refrigerant. It is necessary to fill compressor with lubricant when replacing A/C system parts or when a large amount of refrigerant leakage is detected. It is important to always maintain lubricant level within the specified level. Otherwise, the following conditions may occur.

- Insufficient lubricant amount: Stuck compressor
- Excessive lubricant amount: Insufficient cooling (caused by insufficient heat exchange)

Name : A/C System Oil Type S

Inspection

INFOID:000000011324185

If a compressor is malfunctioning (internal noise, insufficient cooling), check the compressor oil.

1. COMPRESSOR OIL JUDGMENT

1. Remove the compressor. Refer to [HA-30, "Exploded View"](#).
2. Sample a compressor oil and judge on the figure.

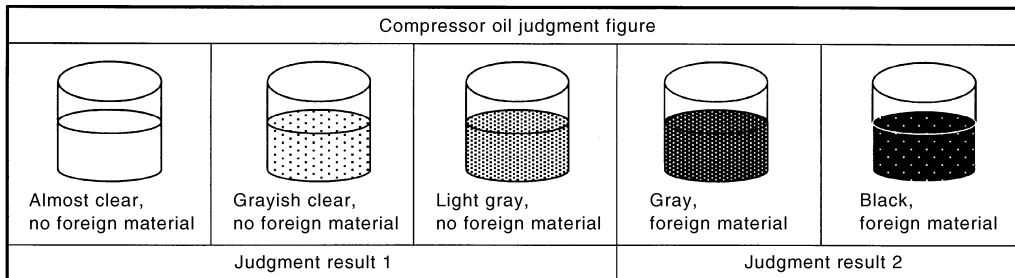

JSIA0927GB

Judgement result 1>>Replace compressor only.

Judgement result 2>>Replace compressor and liquid tank.

Perform Lubricant Return Operation

INFOID:000000011324186

CAUTION:

If a large amount of refrigerant or lubricant leakage is detected, never perform lubricant return operation.

1. Start the engine and set to the following conditions.
 - Engine speed: Idling to 1,200 rpm
 - A/C switch: ON
 - Fan (blower) speed: Maximum speed set
 - Intake door position: Recirculation
 - Temperature setting: Full cold
2. Perform lubricant return operation for approximately 10 minutes.
3. Stop the engine.
4. Lubricant return operation is complete.

Lubricant Adjusting Procedure for Components Replacement Except Compressor

INFOID:000000011324187

Fill with lubricant for the amount that is calculated according to the following conditions.

Example: Lubricant amount to be added when replacing evaporator (front) and liquid tank [m ℓ (US fl oz, Imp fl oz)] = 75 m ℓ (2.5 US fl oz, 2.6 Imp fl oz) + 10 m ℓ (0.3 US fl oz, 0.4 Imp fl oz) + α

LUBRICANT

< BASIC INSPECTION >

Conditions		Lubricant amount to be added to A/C system m ℓ (US fl oz, Imp fl oz)
Replace evaporator	Front A/C unit	75 (2.5, 2.6)
	Rear A/C unit	40 (1.4, 1.4)
Replace condenser		35 (1.2, 1.2)
Replace liquid tank		10 (0.3, 0.4)
Refrigerant leakage is detected	Large amount leakage	30 (1.0, 1.1)
	Small amount leakage	—
Lubricant amount that is recycled together with refrigerant during recycle operation		α

Lubricant Adjusting Procedure for Compressor Replacement

INFOID:000000011324188

1. Drain lubricant from removed compressor and measure lubricant amount.

1. Drain lubricant from high-pressure port (A) and low-pressure port (B) while rotating magnet clutch.
2. Measure total amount of lubricant that is drained from removed compressor.

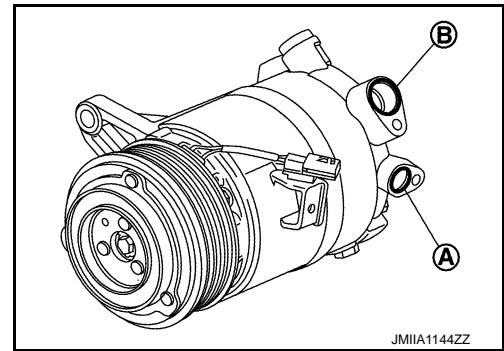

2. Drain lubricant from a new compressor that is calculated according to the following conditions.

Amount to be drained (A)

$$[m \ell \text{ (US fl oz, Imp fl oz)}] = F - (D + S + R + \alpha)$$

F : Lubricant amount that a new compressor contains [250 (8.5, 8.8)]

D : Lubricant amount that is drained from removed compressor

S : Lubricant amount that remains inside of removed compressor [30 (1.0, 1.1)]

R : Lubricant amount to be added according to components that are removed except compressor

α : Lubricant amount that is recycled together with refrigerant during recycle operation

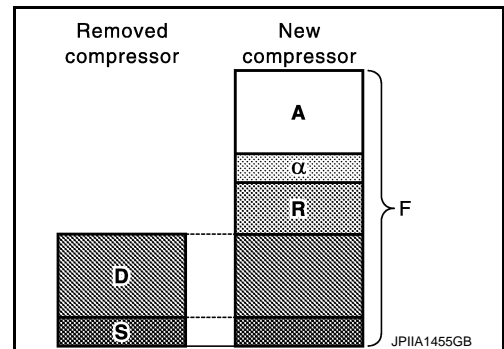

CAUTION:

If lubricant amount that is drained from removed compressor is less than 60 m ℓ (2.0 US fl oz, 2.1 Imp fl oz), perform calculation by setting “D” as 40 m ℓ (1.4 US fl oz, 1.4 Imp fl oz).

Conditions		Lubricant amount to be added to A/C system m ℓ (US fl oz, Imp fl oz)
Replace evaporator	Front	75 (2.5, 2.6)
	Rear	40 (1.4, 1.4)
Replace condenser		35 (1.2, 1.2)
Replace liquid tank		10 (0.3, 0.4)

LUBRICANT

< BASIC INSPECTION >

Example: Lubricant amount to be drained from a new compressor when replacing compressor and liquid tank. [mℓ (US fl oz, Imp fl oz)] [D = 60 (2.0, 2.1), α = 5 (0.2, 0.2)]
 $250 (8.5, 8.8) - [60 (2.0, 2.1) + 30 (1.0, 1.1) + 10 (0.3, 0.4) + 5 (0.2, 0.2)] = 145 (5.0, 5.1)$

3. Install compressor and check the operation.

PERFORMANCE TEST

< BASIC INSPECTION >

PERFORMANCE TEST

Inspection

INFOID:000000011324189

INSPECTION PROCEDURE

1. Connect recovery/recycling/recharging equipment (for HFC-134a) or manifold gauge.
2. Start the engine, and set to the following condition.

Test condition		
Surrounding condition		Indoors or in the shade (in a well-ventilated place)
Vehicle condition	Door	Closed
	Door glass	Full open
	Hood	Open
	Engine speed	Idle speed
A/C condition (front/rear)	Temperature control switch or dial	Full cold
	A/C switch	ON
	Air outlet	VENT (ventilation)
	Intake door position	Recirculation
	Fan (blower) speed	Maximum speed set

3. Maintain test condition until A/C system becomes stable. (Approximately 10 minutes)
4. Check that test results of “recirculating-to-discharge air temperature” and “ambient air temperature-to-operating pressure” are within the specified value.
5. When test results are within the specified value, inspection is complete.
If any of test result is out of the specified value, perform diagnosis by gauge pressure. Refer to [HA-27](#), "[Symptom Table](#)".

RECIRCULATING-TO-DISCHARGE AIR TEMPERATURE TABLE

FRONT

Inside air (Recirculating air) at blower assembly inlet		Discharge air temperature from center ventilator °C (°F)
Relative humidity %	Air temperature °C (°F)	
50 – 60	20 (68)	6.9 - 8.9 (44 - 48)
	25 (77)	10.8 - 13.3 (51 - 56)
	30 (86)	14.9 - 17.9 (58 - 64)
	35 (95)	20.3 - 23.8 (69 - 75)
60 – 70	20 (68)	8.9 - 10.9 (48 - 52)
	25 (77)	13.3 - 15.8 (55 - 60)
	30 (86)	17.9 - 20.9 (64 - 70)
	35 (95)	23.8 - 27.4 (75 - 81)

REAR

Inside air (Recirculating air) at blower assembly inlet		Discharge air temperature from rear ventilator grille A RH* °C (°F)
Relative humidity %	Air temperature °C (°F)	
50 – 60	20 (68)	9.4 - 11.4 (49 - 53)
	25 (77)	13.5 - 15.9 (56 - 61)
	30 (86)	17.5 - 20.5 (63 - 69)
	35 (95)	21.2 - 24.7 (70 - 76)

PERFORMANCE TEST

< BASIC INSPECTION >

Inside air (Recirculating air) at blower assembly inlet		Discharge air temperature from rear ventilator grille A RH* °C (°F)
Relative humidity %	Air temperature °C (°F)	
60 – 70	20 (68)	11.4 - 13.4 (53 - 56)
	25 (77)	15.9 - 18.5 (61 - 65)
	30 (86)	20.5 - 23.6 (69 - 74)
	35 (95)	24.7 - 28.2 (76 - 83)

*: Measuring point of temperature is 5 mm (1.99 in) from air outlet end of rear ventilator grille A RH (passenger room side).

AMBIENT AIR TEMPERATURE-TO-OPERATING PRESSURE TABLE

Fresh air		High-pressure (Discharge side) kPa (kg/cm ² , psi)	Low-pressure (Suction side) kPa (kg/cm ² , psi)
Relative humidity %	Air temperature °C (°F)		
50 – 70	25 (77)	930 - 1,130 (9.5 - 11.5, 134.9 - 163.9)	240 - 300 (2.4 - 3.1, 34.8 - 43.5)
	30 (86)	1,113 - 1,361 (11.3 - 13.9, 161.3 - 197.3)	288 - 351 (2.9 - 3.6, 41.8 - 51.0)
	35 (95)	1,363 - 1,669 (13.9 - 17.0, 197.6 - 242.0)	343 - 424 (3.5 - 4.3, 49.7 - 61.5)
	40 (104)	1,830 - 2,230 (18.7 - 22.7, 265.4 - 323.4)	410 - 500 (4.2 - 5.1, 59.5 - 72.5)

REFRIGERATION SYSTEM SYMPTOMS

< SYMPTOM DIAGNOSIS >

SYMPTOM DIAGNOSIS

REFRIGERATION SYSTEM SYMPTOMS

Trouble Diagnosis For Unusual Pressure

INFOID:0000000011324190

Diagnose using a manifold gauge whenever system's high and/or low side pressure(s) is/are unusual. The marker above the gauge scale in the following tables indicates the standard (usual) pressure range. Refer to above table (Ambient air temperature-to-operating pressure table) since the standard (usual) pressure, however, differs from vehicle to vehicle.

Symptom Table

INFOID:0000000011324191

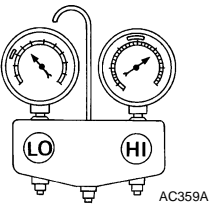
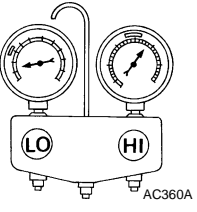
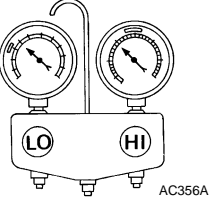
Gauge indication	Refrigerant cycle	Probable cause	Corrective action
<p>Both high- and low-pressure sides are too high.</p> 	<p>The pressure returns to normal soon after sprinkling water on condenser.</p>	<p>Overfilled refrigerant.</p>	<p>Collect all refrigerant, evacuate refrigerant cycle again, and then refill it with the specified amount of refrigerant.</p>
	<p>Air flow to condenser is insufficient.</p>	<p>Insufficient condenser cooling performance.</p> <ul style="list-style-type: none"> • Poor fan rotation of radiator and condenser. • Improper installation of air guide. • Clogged or dirty condenser fins. 	<ul style="list-style-type: none"> • Repair or replace malfunctioning parts. • Clean and repair condenser fins.
	<p>When compressor is stopped, a high-pressure reading quickly drops by approximately 196 kPa (2 kg/cm², 28 psi). It then gradually decreases.</p>	<p>Air mixed in refrigerant cycle.</p>	<p>Collect all refrigerant, evacuate refrigerant cycle again, and then refill it with the specified amount of refrigerant.</p>
	<ul style="list-style-type: none"> • Low-pressure pipe is cooler than the outlet of evaporator. • Low-pressure pipe is frosted. 	<p>Expansion valve opened too much (excessive flow of refrigerant).</p>	<p>Replace expansion valve.</p>
<p>High-pressure side is excessively high and low-pressure side is too low.</p> 	<p>High-pressure pipe and upper side of condenser become hot, however, liquid tank does not become so hot.</p>	<p>Clogged or crushed high-pressure pipe located between compressor and condenser.</p>	<p>Repair or replace the malfunctioning parts.</p>
<p>High-pressure side is too low and low-pressure side is too high.</p> 	<ul style="list-style-type: none"> • The readings of both sides become equal soon after compressor operation stops. • There is no temperature difference between high- and low-pressure sides. 	<p>Malfunction in compressor system (insufficient compressor pressure operation).</p> <ul style="list-style-type: none"> • Damage or breakage of valve. • Malfunctioning gaskets. 	<p>Replace compressor.</p>

REFRIGERATION SYSTEM SYMPTOMS

< SYMPTOM DIAGNOSIS >

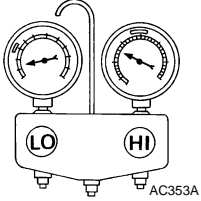
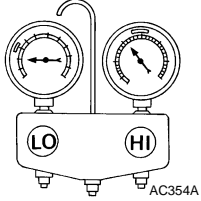
Gauge indication	Refrigerant cycle	Probable cause	Corrective action
<p>Both high- and low-pressure sides are too low.</p> 	<ul style="list-style-type: none"> The area around evaporator outlet does not become cold. The area around evaporator inlet becomes frosted. 	<p>Clogged expansion valve.</p> <ul style="list-style-type: none"> Breakage of temperature sensor. Clogging by foreign material. 	<p>Eliminate foreign material from expansion valve, or replace it.</p>
	<ul style="list-style-type: none"> There is a temperature difference between the areas around outlet and inlet pipes of liquid tank. Liquid tank becomes frosted. 	<p>Malfunction in inner liquid tank (clogged strainer).</p>	<p>Replace liquid tank.</p>
	<p>Evaporator becomes frosted.</p>	<p>Clogged or crushed low-pressure pipe.</p>	<p>Repair or replace malfunctioning parts.</p>
		<p>Malfunction in intake sensor .</p>	<p>Check intake sensor system. Refer to HAC-203, "Diagnosis Procedure".</p>
<p>There is a small temperature difference between the high and low pressure pipes for refrigerant cycle.</p>	<ul style="list-style-type: none"> Shortage of refrigerant. Leakage of refrigerant. 	<ul style="list-style-type: none"> Check for leakage. Collect all refrigerant, evacuate refrigerant cycle again, and then refill it with the specified amount of refrigerant. 	
<p>Low-pressure side sometimes becomes negative.</p> 	<ul style="list-style-type: none"> Sometimes the area around evaporator outlet does not become cold. Sometimes the area around evaporator inlet is frosted. 	<ul style="list-style-type: none"> Icing caused by the mixing of water in cooler cycle. Deteriorated dryer in liquid tank. 	<ul style="list-style-type: none"> Collect all refrigerant. Evacuate refrigerant cycle completely, and then refill it with the specified amount of refrigerant. At this time, always replace liquid tank.

NOISE

< SYMPTOM DIAGNOSIS >

NOISE

Symptom Table

INFOID:000000011324192

Symptom	Noise source	Probable cause	Corrective action
Unusual noise from compressor when A/C is ON.	Inside of compressor	Wear, breakage, or clogging of foreign material in inner parts.	Check compressor oil. Refer to HA-22, "Inspection" .
	Magnet clutch	Contact of clutch disc with pulley.	Check clearance between clutch disc and pulley. Refer to HA-32, "Inspection" .
	Compressor body	Loosened compressor mounting bolts.	Check bolts for tightness. Refer to HA-30, "Exploded View" .
Unusual noise from cooler piping.	Cooler piping (pipe and flexible hose)	Improper installation of clip and bracket.	Check the installation condition of the cooler piping. Refer to HA-34, "Exploded View" .
Unusual noise from expansion valve when A/C is ON.	Expansion valve	Shortage of refrigerant.	<ul style="list-style-type: none"> • Check for leakage. • Collect all refrigerant, evacuate refrigerant cycle again, and then refill it with the specified amount of refrigerant.
		Wear, breakage, or clogging of foreign material in inner parts.	Eliminate foreign material from expansion valve, or replace it.
Unusual noise from belt.	—	Loosened belt	Check belt tension. Refer to EM-15, "Checking" .
		Internal compressor parts get locked	Replace compressor.

A
B
C
D
E
F
G
H
HA
J
K
L
M
N
O
P

COMPRESSOR

< REMOVAL AND INSTALLATION >

REMOVAL AND INSTALLATION

COMPRESSOR

Exploded View

INFOID:000000011324193

REMOVAL

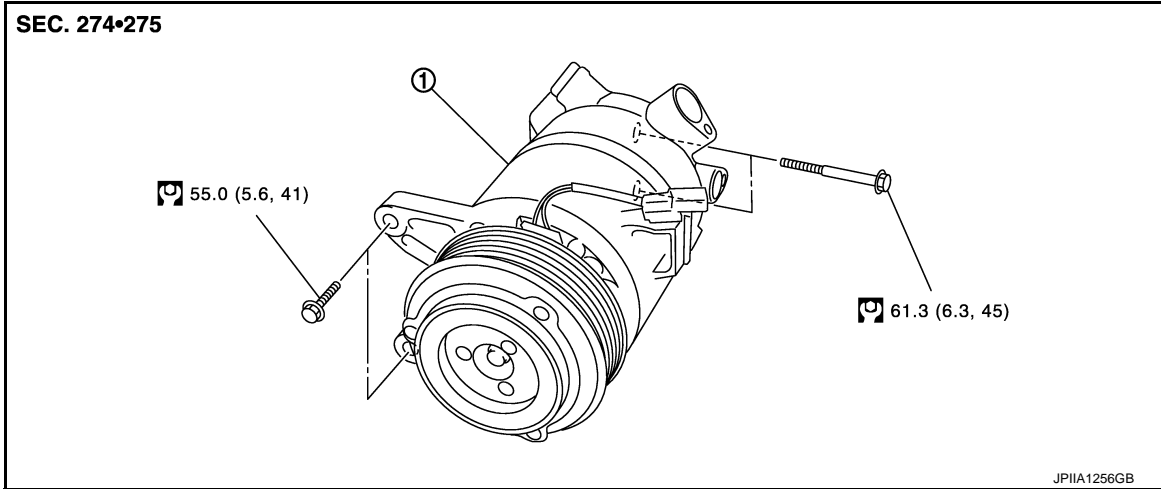

1. Compressor

: N·m (kg·m, ft·lb)

DISASSEMBLY

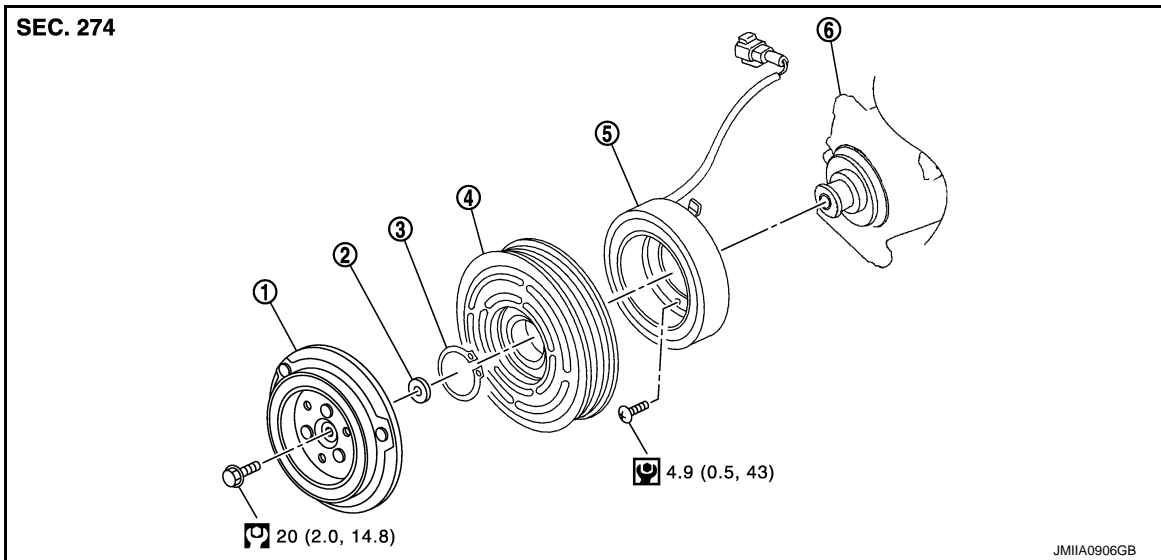

1. Clutch disc

2. Shim

3. Snap ring

4. Pulley assembly

5. Field coil

6. Compressor unit

: N·m (kg·m, ft·lb)

: N·m (kg·m, in·lb)

COMPRESSOR

COMPRESSOR

< REMOVAL AND INSTALLATION >

COMPRESSOR : Removal and Installation

INFOID:000000011324194

CAUTION:

Perform lubricant return operation before each refrigeration system disassembly. However, if a large amount of refrigerant or lubricant is detected, never perform lubricant return operation. Refer to [HA-22, "Perform Lubricant Return Operation"](#).

REMOVAL

1. Use a refrigerant collecting equipment (for HFC-134a) to discharge the refrigerant. Refer to [HA-20, "Recycle Refrigerant"](#).
2. Remove engine under cover. Refer to [EXT-28, "Removal and Installation"](#).
3. Remove splash guard RH. Refer to [EXT-23, "Removal and Installation"](#).
4. Remove drive belt. Refer to [EM-14, "Removal and Installation"](#).
5. Remove mounting bolts (A), and then disconnect low-pressure flexible hose (1) and high-pressure flexible hose (2) from compressor (3).

CAUTION:

- Plug low-pressure port and high-pressure port of compressor to prevent compressor oil leakage.
- Cap or wrap the joint of the low-pressure flexible hose, high-pressure flexible hose, and compressor with suitable material such as vinyl tape to avoid the entry of air.

↶ : Vehicle front

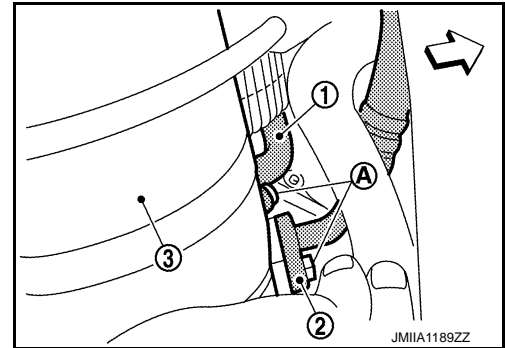

6. Disconnect magnet clutch harness connector (A), and then remove harness fixing clip (B) from compressor.

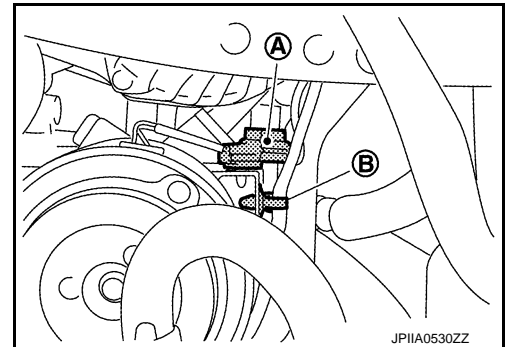

7. Remove return tube fixing clamps, and then move return tube to secure work space. Refer to [ST-35, "Exploded View"](#).
8. Remove compressor mounting bolts, and then remove compressor from the right side of the vehicle.

INSTALLATION

Note the following items, and then install in the reverse order of removal.

CAUTION:

- Tighten compressor mounting bolts in numerical order as shown in the figure.

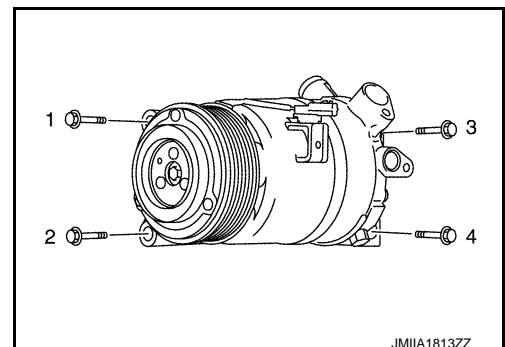

- Replace O-rings with new ones. Then apply compressor oil to them when installing.
- Check tension of the drive belt after installing compressor. Refer to [EM-15, "Checking"](#).

COMPRESSOR

< REMOVAL AND INSTALLATION >

- Check for leakages when recharging refrigerant. Refer to [HA-18, "Leak Test"](#).
- Perform lubricant adjusting procedure before installing new compressor. Refer to [HA-23, "Lubricant Adjusting Procedure for Compressor Replacement"](#).

MAGNET CLUTCH

MAGNET CLUTCH : Removal and Installation of Compressor Clutch

INFOID:000000011324195

REMOVAL

1. Fix clutch disc.
2. Remove center bolt, and then remove clutch disc.
3. Remove snap ring using external snap ring pliers.
4. Position center pulley puller on the end of the drive shaft, and remove pulley assembly using any commercially available pulley puller.
To prevent pulley groove from being deformed, puller claws should be positioned into the edge of the pulley assembly.
5. Disconnect field coil harness from compressor unit.
6. Remove screw, and then remove field coil.

INSTALLATION

1. Install field coil (1).
Be sure to align the coil's pin (2) with the hole in the compressor's front head.
2. Connect field coil harness to compressor unit.

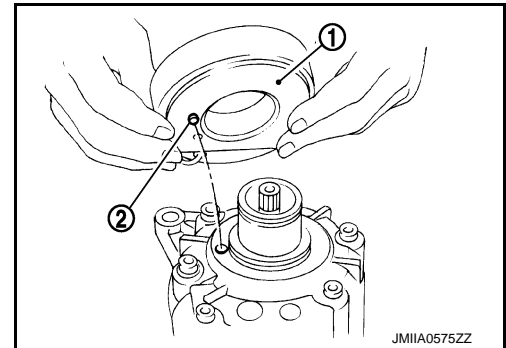

3. Install pulley assembly (1) using installer (SST: J-41260) (A) and a hand press, and then install snap ring (2) using snap ring pliers.

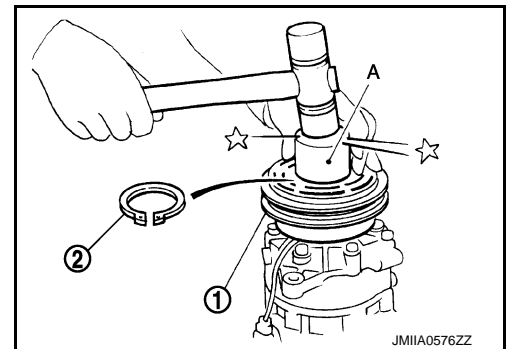

4. Install clutch disc on drive shaft, together with original shim(s). Press clutch disc down by hand.
5. Using holder to prevent clutch disc rotation.
After tightening the bolt, check that the pulley rotates smoothly.

Break-in Operation

When replacing compressor clutch assembly, always carry out the break-in operation. This is done by engaging and disengaging the clutch about thirty-times. Break-in operation raises the level of transmitted torque.

Inspection

INFOID:000000011324196

CHECK DISC TO PULLEY CLEARANCE

COMPRESSOR

< REMOVAL AND INSTALLATION >

Check the clearance (B) between pulley assembly (1) and clutch disc (2) along the entire periphery with a feeler gauge (A).

Clearance : Refer to [HA-60, "Compressor"](#).

CAUTION:

Replace compressor if the specified clearance is not obtained, replace adjusting spacer and readjust.

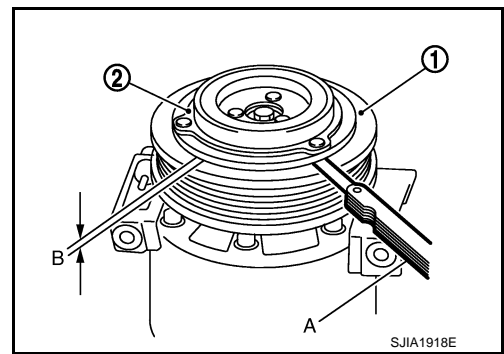

A
B
C
D
E
F
G
H
HA
J
K
L
M
N
O
P

COOLER PIPE AND HOSE

< REMOVAL AND INSTALLATION >

COOLER PIPE AND HOSE

Exploded View

INFOID:000000011324197

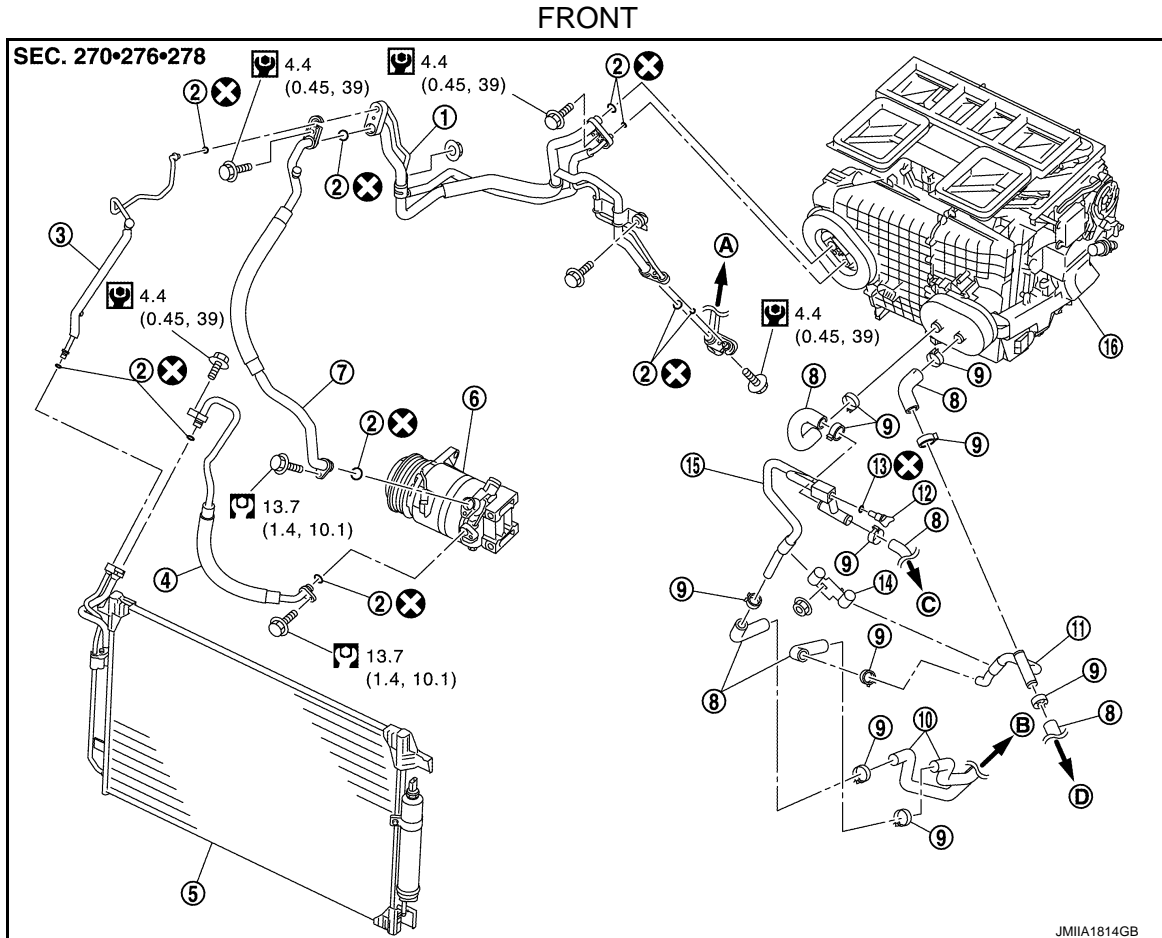

- | | | |
|------------------------------------|-------------------------------|-----------------------------|
| 1. Front cooler pipe assembly | 2. O-ring | 3. High-pressure pipe |
| 4. High-pressure flexible hose | 5. Condenser | 6. Compressor |
| 7. Low-pressure flexible hose | 8. Heater hose | 9. Clamp |
| 10. Heater pipe | 11. Rear heater inlet tube | 12. Drain cock |
| 13. Drain cock packing | 14. Front cooler pipe bracket | 15. Rear heater outlet tube |
| 16. Heater & cooling unit assembly | | |
| A. To rear cooler cycle | B. To rear heater cycle | C. To heater outlet |
| D. To heater inlet | | |

⊗ : Always replace after every disassembly.

☐ : N·m (kg-m, ft-lb)

☐ : N·m (kg-m, in-lb)

COOLER PIPE AND HOSE

< REMOVAL AND INSTALLATION >

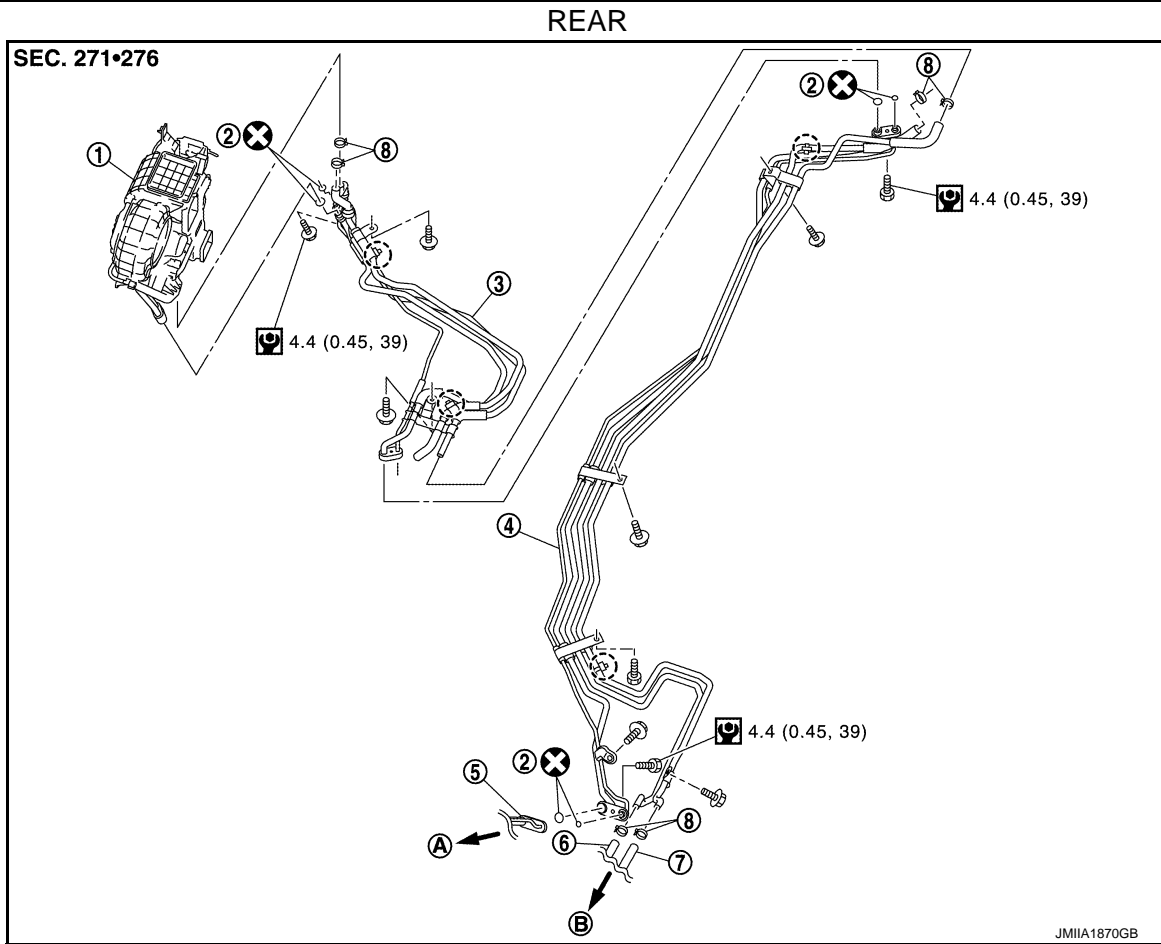

- | | | |
|--------------------------------|-------------------------------|--------------------------------|
| 1. Rear A/C unit assembly | 2. O-ring | 3. Rear cooler pipe assembly 2 |
| 4. Rear cooler pipe assembly 1 | 5. Front cooler pipe assembly | 6. Heater hose |
| 7. Heater hose | 8. Clamp | |
| A. To front cooler cycle | B. To front heater cycle | |

○ : Clip

⊗ : Always replace after every disassembly.

Ⓜ : N·m (kg·m, in·lb)

HIGH-PRESSURE FLEXIBLE HOSE

HIGH-PRESSURE FLEXIBLE HOSE : Removal and Installation

INFOID:000000011324198

CAUTION:

Perform lubricant return operation before each refrigeration system disassembly. However, if a large amount of refrigerant or lubricant is detected, never perform lubricant return operation. Refer to [HA-22, "Perform Lubricant Return Operation"](#).

REMOVAL

- Use a refrigerant collecting equipment (for HFC-134a) to discharge the refrigerant. Refer to [HA-20, "Recycle Refrigerant"](#).
- Remove mounting bolt, and then disconnect high-pressure flexible hose from compressor. Refer to [HA-31, "COMPRESSOR : Removal and Installation"](#).

CAUTION:

- Plug high-pressure port of compressor to prevent compressor oil leakage.
- Cap or wrap the joint of the A/C piping and compressor with suitable material such as vinyl tape to avoid the entry of air.

COOLER PIPE AND HOSE

< REMOVAL AND INSTALLATION >

3. Remove mounting bolt (A), and then disconnect high-pressure pipe (1) and high-pressure flexible hose (2) from condenser pipe assembly.

CAUTION:

Cap or wrap the joint of the A/C piping with suitable material such as vinyl tape to avoid the entry of air.

⇐ : Vehicle front

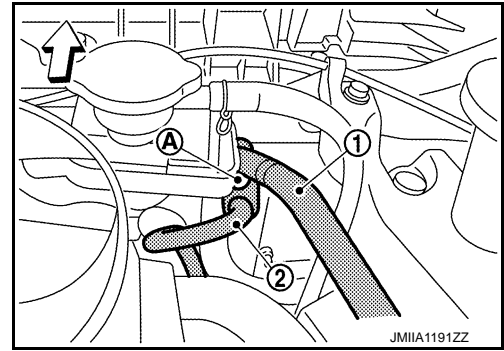

4. Remove high-pressure flexible hose from the vehicle.

INSTALLATION

Note the following items, and then install in the reverse order of removal.

CAUTION:

- Replace O-rings with new ones. Then apply compressor oil to them when installing.
- Check for leakages when recharging refrigerant. Refer to [HA-18, "Leak Test"](#).

LOW-PRESSURE FLEXIBLE HOSE

LOW-PRESSURE FLEXIBLE HOSE : Removal and Installation

INFOID:000000011324199

CAUTION:

Perform lubricant return operation before each refrigeration system disassembly. However, if a large amount of refrigerant or lubricant is detected, never perform lubricant return operation. Refer to [HA-22, "Perform Lubricant Return Operation"](#).

REMOVAL

1. Use a refrigerant collecting equipment (for HFC-B4a) to discharge the refrigerant. Refer to [HA-20, "Recycle Refrigerant"](#).
2. Remove mounting bolt, and then disconnect low-pressure flexible hose from compressor. Refer to [HA-31, "COMPRESSOR : Removal and Installation"](#).

CAUTION:

- Plug low-pressure port of compressor to prevent compressor oil leakage.
- Cap or wrap the joint of the A/C piping and compressor with suitable material such as vinyl tape to avoid the entry of air.

3. Remove mounting bolt (A), and then disconnect low-pressure flexible hose (1) and high-pressure pipe (2) from front cooler pipe assembly (3).

CAUTION:

Cap or wrap the joint of the A/C piping with suitable material such as vinyl tape to avoid the entry of air.

⇐ : Vehicle front

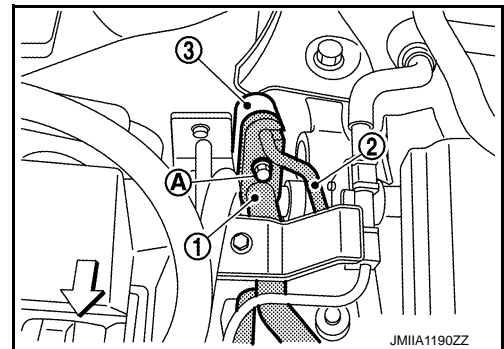

4. Remove low-pressure flexible hose from the vehicle.

INSTALLATION

Note the following items, and then install in the reverse order of removal.

CAUTION:

- Replace O-rings with new ones. Then apply compressor oil to them when installing.
- Check for leakages when recharging refrigerant. Refer to [HA-18, "Leak Test"](#).

HIGH-PRESSURE PIPE

HIGH-PRESSURE PIPE : Removal and Installation

INFOID:000000011324200

CAUTION:

COOLER PIPE AND HOSE

< REMOVAL AND INSTALLATION >

Perform lubricant return operation before each refrigeration system disassembly. However, if a large amount of refrigerant or lubricant is detected, never perform lubricant return operation. Refer to [HA-22, "Perform Lubricant Return Operation"](#).

REMOVAL

1. Use a refrigerant collecting equipment (for HFC-134a) to discharge the refrigerant. Refer to [HA-20, "Recycle Refrigerant"](#).
2. Remove mounting bolt (A), and then disconnect low-pressure flexible hose (1) and high-pressure pipe (2) from front cooler pipe assembly (3).

CAUTION:

Cap or wrap the joint of the A/C piping with suitable material such as vinyl tape to avoid the entry of air.

← : Vehicle front

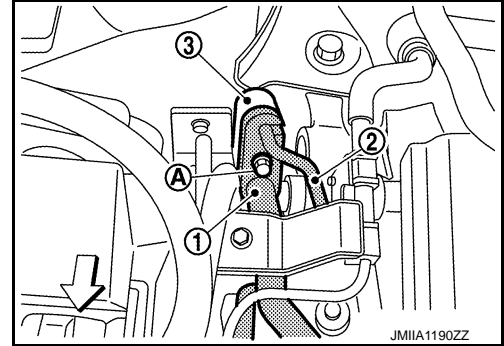

3. Remove mounting bolt (A), and then disconnect high-pressure pipe (1) and high-pressure flexible hose (2) from condenser pipe assembly.

CAUTION:

Cap or wrap the joint of the A/C piping with suitable material such as vinyl tape to avoid the entry of air.

← : Vehicle front

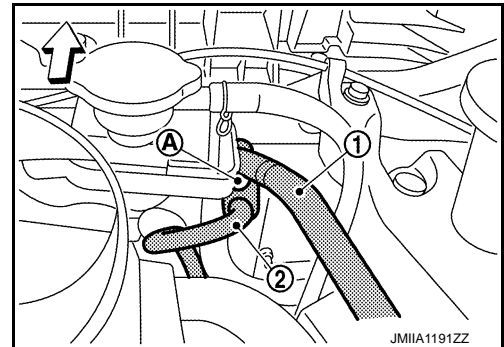

4. Remove fixing clips, and then remove high-pressure pipe from the vehicle.

INSTALLATION

Note the following items, and then install in the reverse order of removal.

CAUTION:

- Replace O-rings with new ones. Then apply compressor oil to them when installing.
- Check for leakages when recharging refrigerant. Refer to [HA-18, "Leak Test"](#).

COOLER PIPE ASSEMBLY

COOLER PIPE ASSEMBLY : Removal and Installation

INFOID:000000011324201

CAUTION:

Perform lubricant return operation before each refrigeration system disassembly. However, if a large amount of refrigerant or lubricant is detected, never perform lubricant return operation. Refer to [HA-22, "Perform Lubricant Return Operation"](#).

REMOVAL

1. Use a refrigerant collecting equipment (for HFC-134a) to discharge the refrigerant. Refer to [HA-20, "Recycle Refrigerant"](#).
2. Drain engine coolant from cooling system. Refer to [CO-8, "Draining"](#).
3. Remove cowl top extension. Refer to [EXT-22, "Removal and Installation"](#).
4. Remove intake manifold collector. Refer to [EM-30, "Removal and Installation"](#).

COOLER PIPE AND HOSE

< REMOVAL AND INSTALLATION >

5. Remove fixing clamps (A), and then disconnect heater hoses from heater & cooling unit assembly.

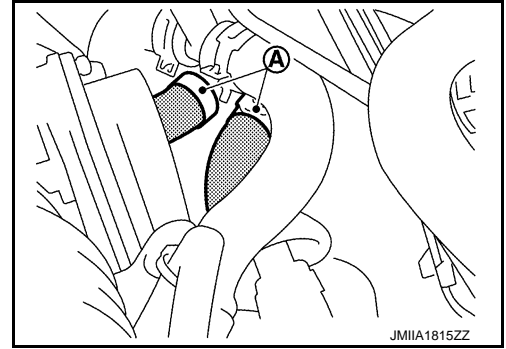

6. Remove fixing clamps (A), and then disconnect heater hoses from rear heater tube. (inlet and outlet)

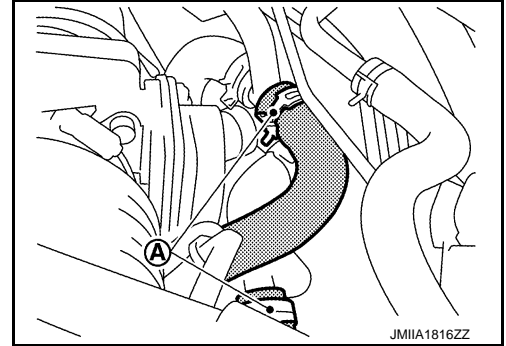

7. Remove mounting bolt (A), and then disconnect low-pressure flexible hose (1) and high-pressure pipe (2) from front cooler pipe assembly (3).

CAUTION:

Cap or wrap the joint of the A/C piping with suitable material such as vinyl tape to avoid the entry of air.

← : Vehicle front

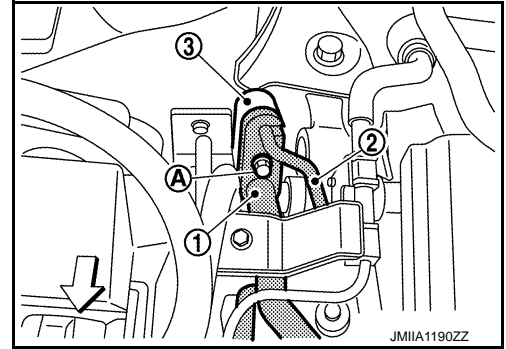

8. Remove mounting bolt (A), and then disconnect front cooler pipe assembly (2) from expansion valve (1).

CAUTION:

Cap or wrap the joint of the A/C piping and expansion valve with suitable material such as vinyl tape to avoid the entry of air.

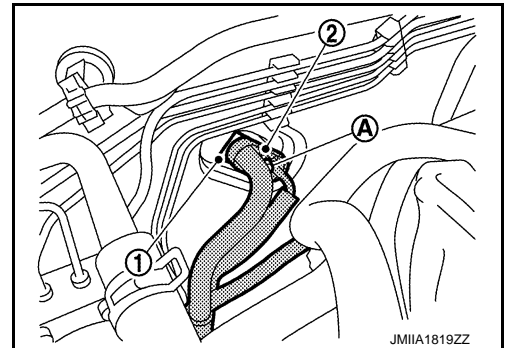

9. Remove front cooler pipe assembly mounting bolt and nut from engine room. Refer to [HA-34. "Exploded View"](#).

COOLER PIPE AND HOSE

< REMOVAL AND INSTALLATION >

10. Remove mounting nuts (A) and bolt (B), and then remove heat insulator.

CAUTION:

- **Work when system is cool, as the exhaust system is hot just after stopping the engine.**
- **Be careful not to cut hands on the edge of heat shield plate.**

⇐ : Vehicle front

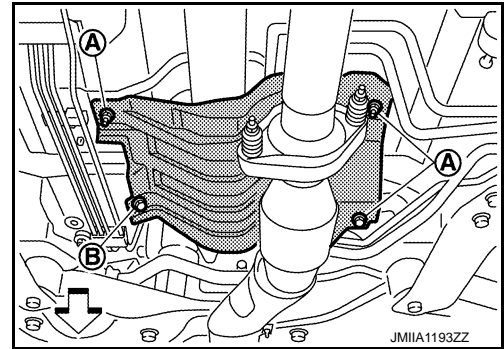

11. Remove mounting bolt (A) and fixing clip (B) so that rear cooler pipe assembly 1 can be moved freely to secure work space.

⇐ : Vehicle front

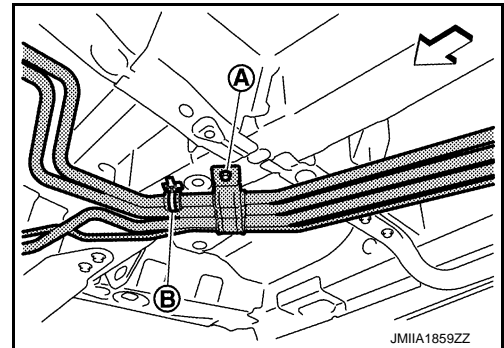

12. Remove mounting bolt (A) so that rear cooler pipe assembly 1 can be moved freely to secure work space.

⇐ : Vehicle front

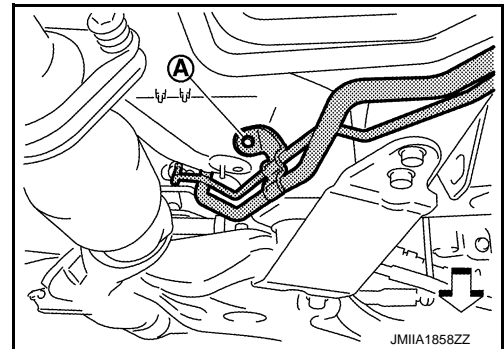

13. Remove mounting bolt (A) so that rear cooler pipe assembly 1 can be moved freely to secure work space.

⇐ : Vehicle front

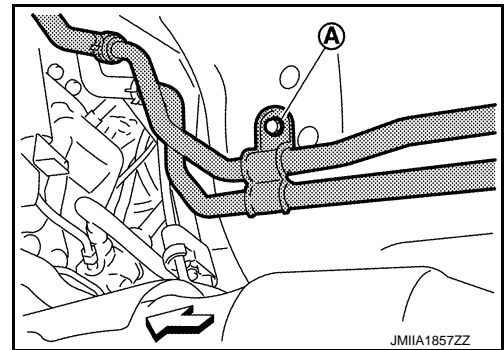

14. Remove mounting bolt (A), and then disconnect rear cooler pipe assembly 1 from front cooler pipe assembly.

CAUTION:

- **Cap or wrap the joint of the A/C piping with suitable material such as vinyl tape to avoid the entry of air.**

⇐ : Vehicle front

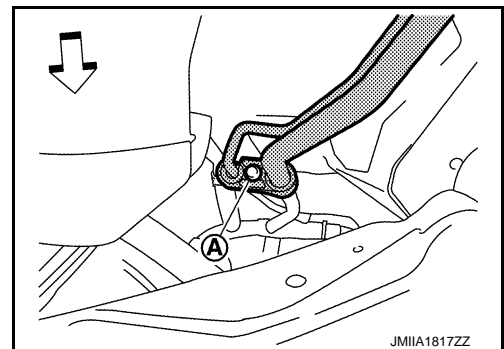

A
B
C
D
E
F
G
H
HA
J
K
L
M
N
O
P

COOLER PIPE AND HOSE

< REMOVAL AND INSTALLATION >

15. Remove front cooler pipe assembly from underneath the vehicle.

CAUTION:

Cap or wrap the joint of the A/C piping with suitable material such as vinyl tape to avoid the entry of air.

⇐ : Vehicle front

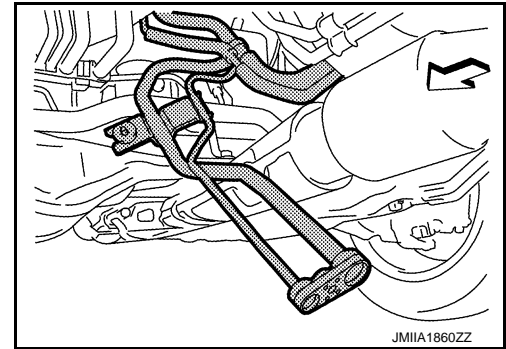

INSTALLATION

Note the following items, and then install in the reverse order of removal.

CAUTION:

- Replace O-rings with new ones. Then apply compressor oil to them when installing.
- Check for leakages when recharging refrigerant. Refer to [HA-18, "Leak Test"](#).

REAR COOLER PIPE 1

REAR COOLER PIPE 1 : Removal and Installation

INFOID:000000011324202

CAUTION:

Perform lubricant return operation before each refrigeration system disassembly. However, if a large amount of refrigerant or lubricant is detected, never perform lubricant return operation. Refer to [HA-22, "Perform Lubricant Return Operation"](#).

REMOVAL

1. Use a refrigerant collecting equipment (for HFC-134a) to discharge the refrigerant. Refer to [HA-20, "Recycle Refrigerant"](#).
2. Drain engine coolant from cooling system. Refer to [CO-8, "Draining"](#).
3. Remove mounting nuts (A) and bolt (B), and then remove heat insulator.

CAUTION:

- Work when system is cool, as the exhaust system is hot just after stopping the engine.
- Be careful not to cut hands on the edge of heat shield plate.

⇐ : Vehicle front

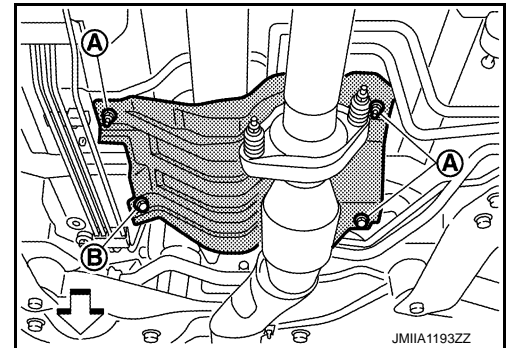

4. Remove exhaust front tube. Refer to [EX-6, "Removal and Installation"](#).

CAUTION:

Block the openings with tape to make sure that no foreign materials get inside engine.

5. Remove rear cooler pipe assembly 1 mounting bolt (A).

⇐ : Vehicle front

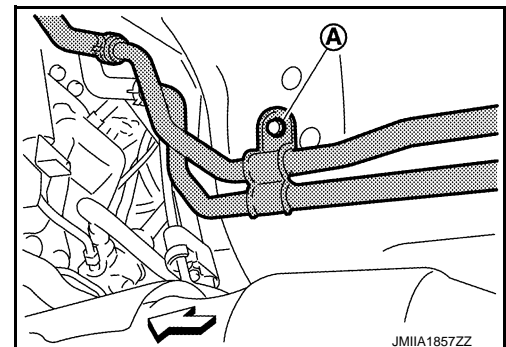

COOLER PIPE AND HOSE

< REMOVAL AND INSTALLATION >

6. Remove rear cooler pipe assembly 1 mounting bolt (A).

↔ : Vehicle front

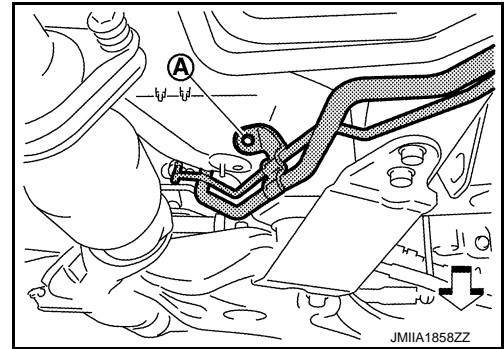

7. Remove rear cooler pipe assembly 1 mounting bolt (A) and fixing clip (B).

↔ : Vehicle front

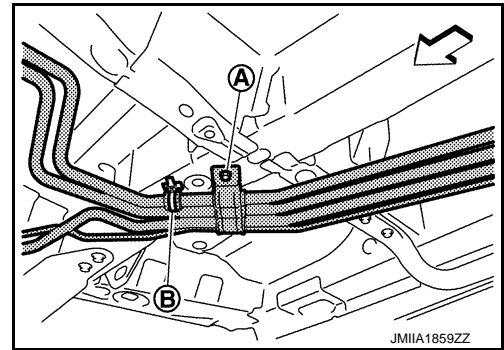

8. Remove mounting bolt (A), and then disconnect rear cooler pipe assembly 1 from front cooler pipe assembly.

CAUTION:

Cap or wrap the joint of the A/C piping with suitable material such as vinyl tape to avoid the entry of air.

↔ : Vehicle front

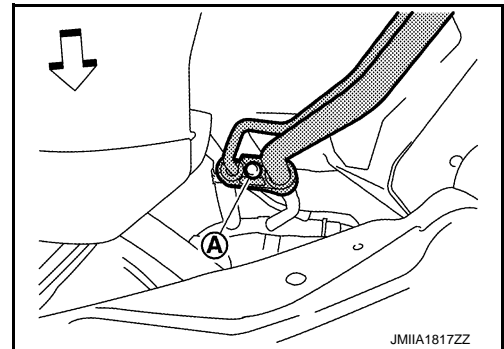

9. Remove fixing clamps (A), and then disconnect heater hoses (1) from rear cooler pipe assembly 1 (2).

↔ : Vehicle front

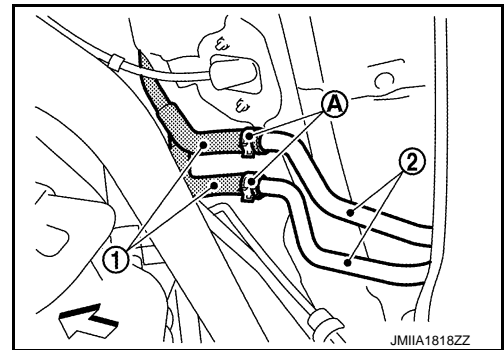

10. Remove mounting bolt (A) and fixing clamps (B), and then disconnect rear cooler pipe assembly 1 (1) from rear cooler pipe assembly 2 (2).

CAUTION:

Cap or wrap the joint of the A/C piping with suitable material such as vinyl tape to avoid the entry of air.

↔ : Vehicle front

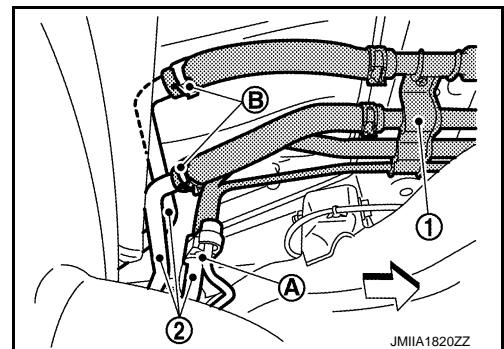

A
B
C
D
E
F
G
H
HA
J
K
L
M
N
O
P

COOLER PIPE AND HOSE

< REMOVAL AND INSTALLATION >

11. Remove rear cooler pipe assembly 1 bracket mounting bolts and fixing clips, and then remove rear cooler pipe assembly 1 from the vehicle.

INSTALLATION

Note the following items, and then install in the reverse order of removal.

CAUTION:

- Replace O-rings with new ones. Then apply compressor oil to them when installing.
- Check for leakages when recharging refrigerant. Refer to [HA-18, "Leak Test"](#).

REAR COOLER PIPE 2

REAR COOLER PIPE 2 : Removal and Installation

INFOID:000000011324203

CAUTION:

Perform lubricant return operation before each refrigeration system disassembly. However, if a large amount of refrigerant or lubricant is detected, never perform lubricant return operation. Refer to [HA-22, "Perform Lubricant Return Operation"](#).

REMOVAL

1. Use a refrigerant collecting equipment (for HFC-134a) to discharge the refrigerant. Refer to [HA-20, "Recycle Refrigerant"](#).
2. Drain engine coolant from cooling system. Refer to [CO-8, "Draining"](#).
3. Remove rear suspension member. Refer to [RSU-19, "Removal and Installation"](#).
4. Remove mounting bolt (A) and fixing clamps (B), and then disconnect rear cooler pipe assembly 1 (1) from rear cooler pipe assembly 2 (2).

CAUTION:

Cap or wrap the joint of the A/C piping with suitable material such as vinyl tape to avoid the entry of air.

← : Vehicle front

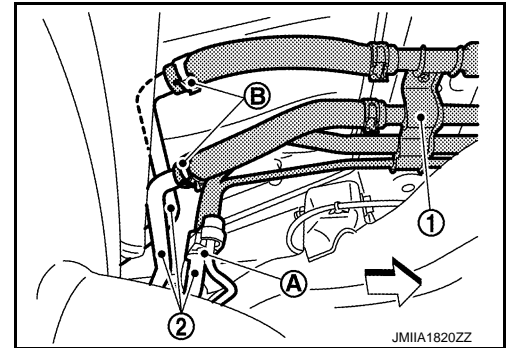

5. Remove rear bumper closing. Refer to [EXT-17, "REAR BUMPER CLOSING : Removal and Installation"](#).
6. Remove mounting bolt (A) and fixing clamps (B), and then disconnect rear cooler pipe assembly 2 from rear A/C unit assembly.

CAUTION:

Cap or wrap the joint of the A/C piping and rear A/C unit assembly with suitable material such as vinyl tape to avoid the entry of air.

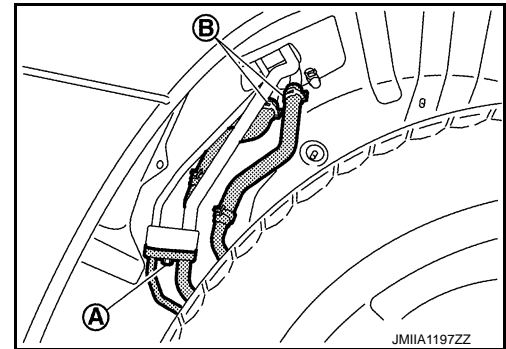

7. Remove rear cooler pipe assembly 2 mounting bolts and fixing clips, and then remove rear cooler pipe assembly 2 from the vehicle.

INSTALLATION

Note the following items, and then install in the reverse order of removal.

CAUTION:

- Replace O-rings with new ones. Then apply compressor oil to them when installing.
- Check for leakages when recharging refrigerant. Refer to [HA-18, "Leak Test"](#).

CONDENSER

< REMOVAL AND INSTALLATION >

CONDENSER

Exploded View

INFOID:0000000011324204

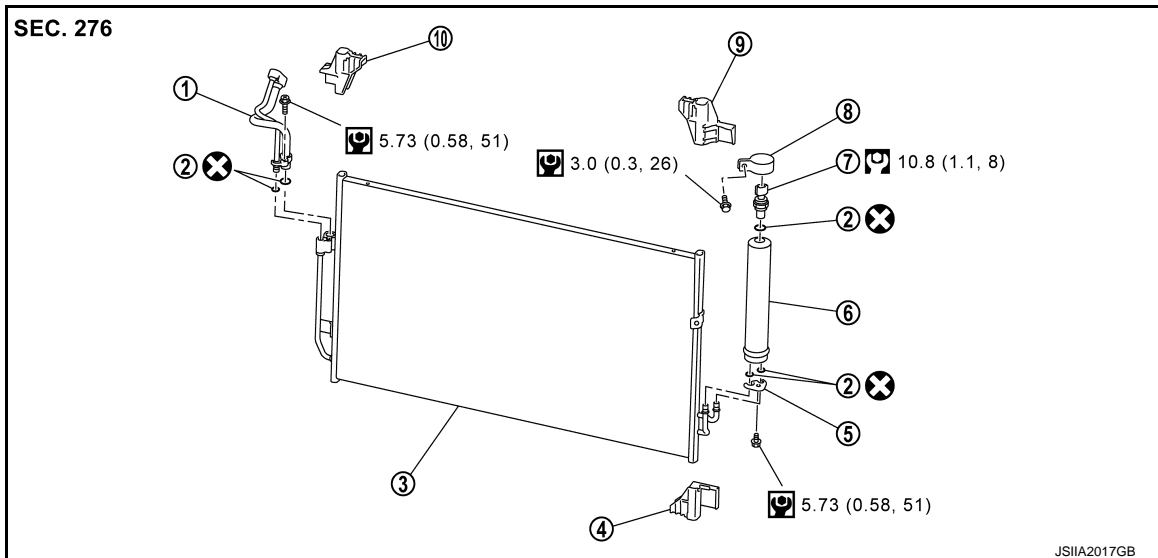

- | | | |
|--------------------------------|------------------------|-------------------------------|
| 1. Condenser pipe assembly | 2. O-ring | 3. Condenser |
| 4. Condenser lower bracket | 5. Bracket | 6. Liquid tank |
| 7. Refrigerant pressure sensor | 8. Liquid tank bracket | 9. Condenser upper bracket LH |
| 10. Condenser upper bracket RH | | |

⊗ : Always replace after every disassembly.

🔧 : N·m (kg-m, ft-lb)

🔧 : N·m (kg-m, in-lb)

CONDENSER

CONDENSER : Removal and Installation

INFOID:0000000011324205

CAUTION:

Perform lubricant return operation before each refrigeration system disassembly. However, if a large amount of refrigerant or lubricant is detected, never perform lubricant return operation. Refer to [HA-22, "Perform Lubricant Return Operation"](#).

REMOVAL

1. Use a refrigerant collecting equipment (for HFC-134a) to discharge the refrigerant. Refer to [HA-20, "Recycle Refrigerant"](#).
2. Remove condenser pipe assembly. Refer to [HA-44, "CONDENSER PIPE ASSEMBLY : Removal and Installation"](#).

CAUTION:

Cap or wrap the joint of the condenser pipe assembly and condenser with suitable material such as vinyl tape to avoid the entry of air.

3. Remove horn assembly. Refer to [HRN-6, "Removal and Installation"](#).
4. Remove air guide upper. Refer to [DLK-421, "Removal and Installation"](#).
5. Disconnect refrigerant pressure sensor harness connector.
6. Pull up condenser toward vehicle upper to remove.

CAUTION:

Be careful not to damage core surface of condenser.

INSTALLATION

Note the following items, and then install in the reverse order of removal.

CONDENSER

< REMOVAL AND INSTALLATION >

CAUTION:

- Replace O-rings with new ones. Then apply compressor oil to them when installing.
- Perform lubricant adjusting procedure before installing new condenser. Refer to [HA-22, "Lubricant Adjusting Procedure for Components Replacement Except Compressor"](#).
- Check for leakages when recharging refrigerant. Refer to [HA-18, "Leak Test"](#).

CONDENSER PIPE ASSEMBLY

CONDENSER PIPE ASSEMBLY : Removal and Installation

INFOID:000000011324206

REMOVAL

1. Use a refrigerant collecting equipment (for HFC-134a) to discharge the refrigerant. Refer to [HA-20, "Recycle Refrigerant"](#).
2. Remove front grille. Refer to [EXT-18, "Removal and Installation"](#).
3. Remove mounting bolt (A), and then disconnect high-pressure pipe (1) and high-pressure flexible hose (2) from condenser pipe assembly.

CAUTION:

Cap or wrap the joint of the A/C piping and condenser pipe assembly with suitable material such as vinyl tape to avoid the entry of air.

← : Vehicle front

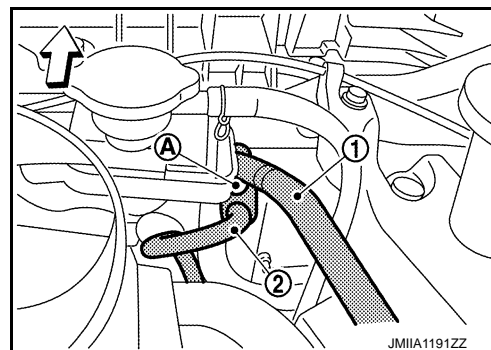

4. Remove mounting bolt (A), and then disconnect condenser pipe assembly from condenser.

CAUTION:

Cap or wrap the joint of the condenser pipe assembly and condenser with suitable material such as vinyl tape to avoid the entry of air.

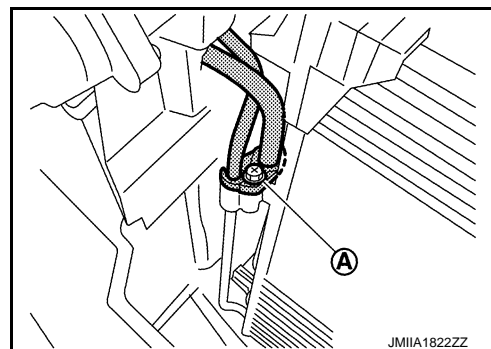

5. Remove air guide side RH. Refer to [DLK-421, "Exploded View"](#).
6. Remove condenser pipe assembly from the vehicle.

INSTALLATION

Note the following items, and then install in the reverse order of removal.

CAUTION:

- Replace O-rings with new ones. Then apply compressor oil to them when installing.
- Check for leakages when recharging refrigerant. Refer to [HA-18, "Leak Test"](#).

LIQUID TANK

LIQUID TANK : Removal and Installation

INFOID:000000011324207

CAUTION:

Perform lubricant return operation before each refrigeration system disassembly. However, if a large amount of refrigerant or lubricant is detected, never perform lubricant return operation. Refer to [HA-22, "Perform Lubricant Return Operation"](#).

REMOVAL

1. Use a refrigerant collecting equipment (for HFC-134a) to discharge the refrigerant. Refer to [HA-20, "Recycle Refrigerant"](#).
2. Remove front grille. Refer to [EXT-18, "Removal and Installation"](#).
3. Clean liquid tank and its surrounding area, and then remove dust and rust from liquid tank.

CONDENSER

< REMOVAL AND INSTALLATION >

CAUTION:

Be sure to clean carefully.

4. Disconnect refrigerant pressure sensor harness connector (A).
5. Remove liquid tank mounting bolt (C) and liquid tank bracket mounting bolt (B), and then remove liquid tank from condenser.

CAUTION:

- Be careful not to damage core surface of condenser.
- Cap or wrap the joint of the liquid tank and condenser with suitable material such as vinyl tape to avoid the entry of air.

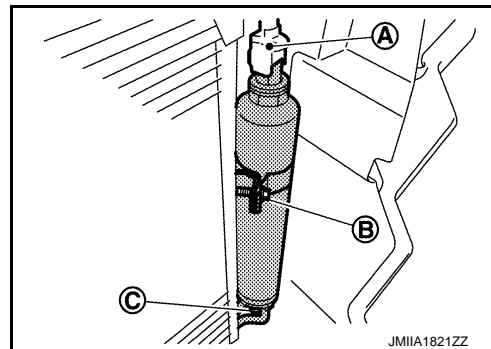

INSTALLATION

Note the following items, and then install in the reverse order of removal.

CAUTION:

- Replace O-rings with new ones. Then apply compressor oil to them when installing.
- Perform lubricant adjusting procedure before installing new liquid tank. Refer to [HA-22, "Lubricant Adjusting Procedure for Components Replacement Except Compressor"](#).
- Check for leakages when recharging refrigerant. Refer to [HA-18, "Leak Test"](#).

REFRIGERANT PRESSURE SENSOR

REFRIGERANT PRESSURE SENSOR : Removal and Installation

INFOID:000000011324208

CAUTION:

Perform lubricant return operation before each refrigeration system disassembly. However, if a large amount of refrigerant or lubricant is detected, never perform lubricant return operation. Refer to [HA-22, "Perform Lubricant Return Operation"](#).

REMOVAL

1. Use a refrigerant collecting equipment (for HFC-134a) to discharge the refrigerant. Refer to [HA-20, "Recycle Refrigerant"](#).
2. Clean refrigerant pressure sensor and its surrounding area, and then remove dust and rust from refrigerant pressure sensor.

CAUTION:

Be sure to clean carefully.

3. Remove liquid tank. Refer to [HA-44, "LIQUID TANK : Removal and Installation"](#).

CAUTION:

- Be careful not to damage liquid tank.
- Cap or wrap the joint of the liquid tank and condenser with suitable material such as vinyl tape to avoid the entry of air.

4. Fix the liquid tank (1) using a vice (A).
5. Remove refrigerant pressure sensor (2) using a wrench (B).

CAUTION:

Be careful not to damage liquid tank.

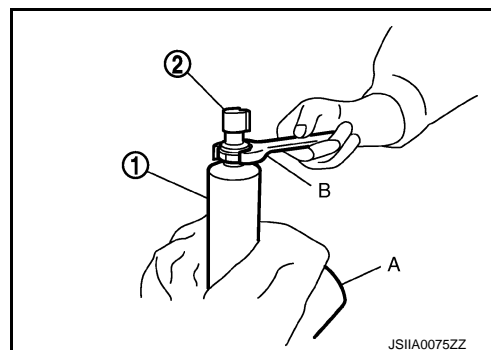

INSTALLATION

Note the following items, and then install in the reverse order of removal.

CAUTION:

- Replace O-ring with new one. Then apply compressor oil to them when installing.
- Check for leakages when recharging refrigerant. Refer to [HA-18, "Leak Test"](#).

A/C UNIT ASSEMBLY

< REMOVAL AND INSTALLATION >

A/C UNIT ASSEMBLY

Exploded View

INFOID:000000011324209

REMOVAL

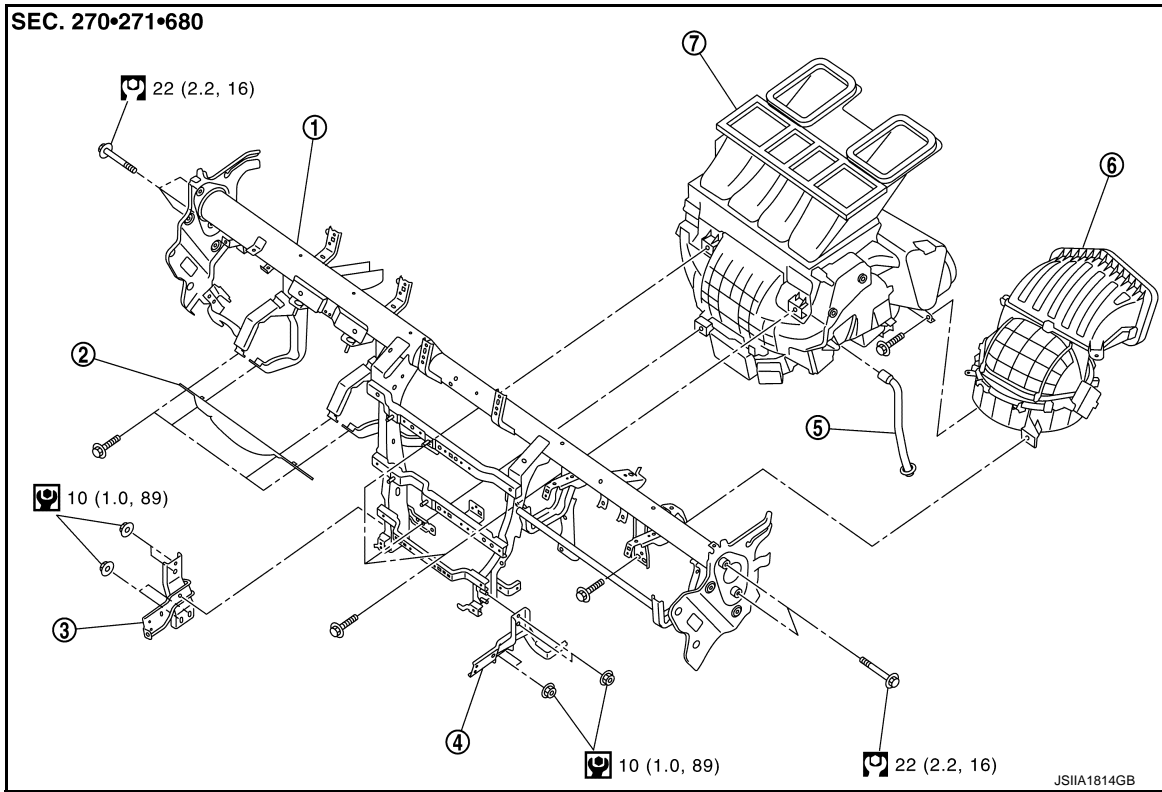

- | | | |
|-----------------------------------|-------------------|-------------------------|
| 1. Steering member | 2. Knee protector | 3. Instrument stay LH |
| 4. Instrument stay RH | 5. Drain hose | 6. Blower unit assembly |
| 7. Heater & cooling unit assembly | | |

: N·m (kg-m, ft-lb)

: N·m (kg-m, in-lb)

DISASSEMBLY

A/C UNIT ASSEMBLY

< REMOVAL AND INSTALLATION >

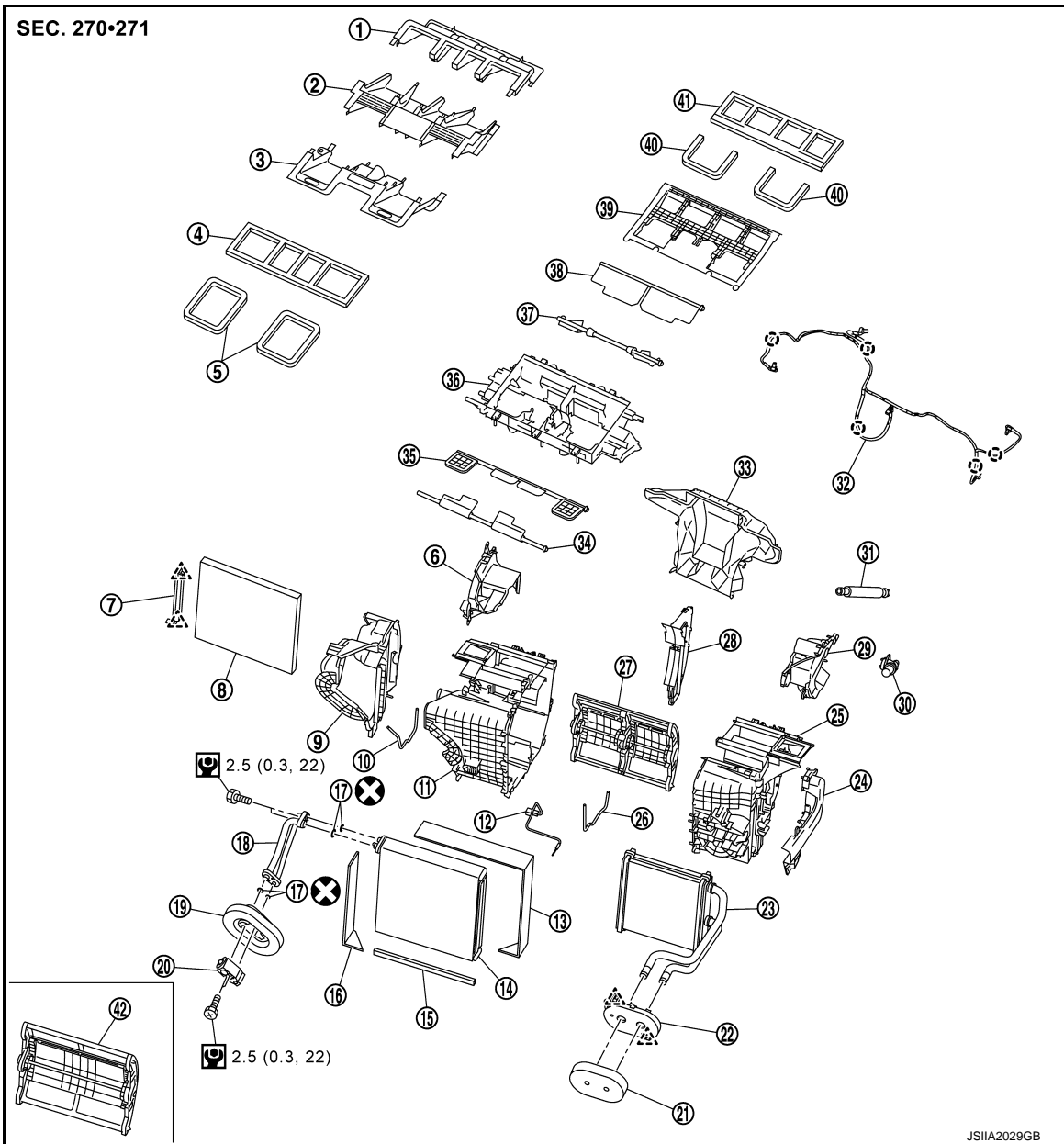



- | | | |
|-----------------------------------|-----------------------------------|--------------------------------------|
| 1. Adapter duct rear | 2. Adapter duct center | 3. Adapter duct front |
| 4. Ventilator duct packing | 5. Defroster duct packing | 6. Foot duct RH |
| 7. Filter cover | 8. In-cabin microfilter | 9. Heater & cooling unit case cover |
| 10. Case packing 2 | 11. Heater & cooling unit case RH | 12. Intake sensor |
| 13. Insulator 1 | 14. Evaporator | 15. Insulator 3 |
| 16. Insulator 2 | 17. O-ring | 18. Evaporator pipe assembly |
| 19. Cooler grommet | 20. Expansion valve | 21. Heater pipe grommet |
| 22. Heater pipe support | 23. Heater core | 24. Heater pipe cover |
| 25. Heater & cooling unit case LH | 26. Case packing 1 | 27. Air mix door (Slide door unit)*1 |
| 28. Center case | 29. Foot duct LH | 30. Aspirator*1 |
| 31. Aspirator duct*1 | 32. Sub harness | 33. Adapter case |
| 34. Max. cool door | 35. Foot door | 36. Distributor case lower |
| 37. Defroster door | 38. Ventilator door | 39. Distributor case upper |
| 40. Defroster packing | 41. Ventilator packing | 42. Air mix door (Slide door unit)*2 |

○ : Clip

A/C UNIT ASSEMBLY

< REMOVAL AND INSTALLATION >

 : Pawl

 : Always replace after every disassembly.

 : N·m (kg·m, in·lb)

*1: Automatic air conditioning

*2: Manual air conditioning

HEATER & COOLING UNIT ASSEMBLY

HEATER & COOLING UNIT ASSEMBLY : Removal and Installation

INFOID:000000011324210

CAUTION:

Perform lubricant return operation before each refrigeration system disassembly. However, if a large amount of refrigerant or lubricant is detected, never perform lubricant return operation. Refer to [HA-22, "Perform Lubricant Return Operation"](#).

REMOVAL

1. Use a refrigerant collecting equipment (for HFC-134a) to discharge the refrigerant. Refer to [HA-20, "Recycle Refrigerant"](#).
2. Drain engine coolant from cooling system. Refer to [CO-8, "Draining"](#).
3. Remove cowl top extension. Refer to [EXT-22, "Removal and Installation"](#).
4. Remove electric throttle control actuator. Refer to [EM-30, "Removal and Installation"](#).
5. Remove fixing clamps (A), and then disconnect heater hose from heater & cooling unit assembly.

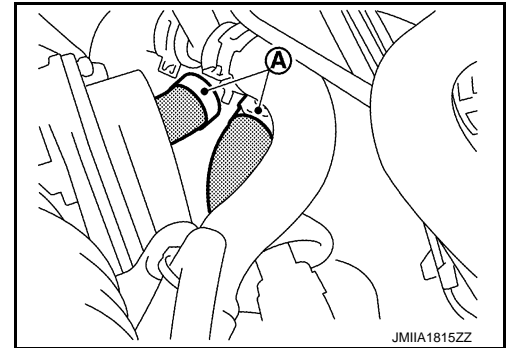

6. Remove mounting bolt (A), and then disconnect front cooler pipe assembly (2) from expansion valve (1).

CAUTION:

Cap or wrap the joint of the A/C piping and expansion valve with suitable material such as vinyl tape to avoid the entry of air.

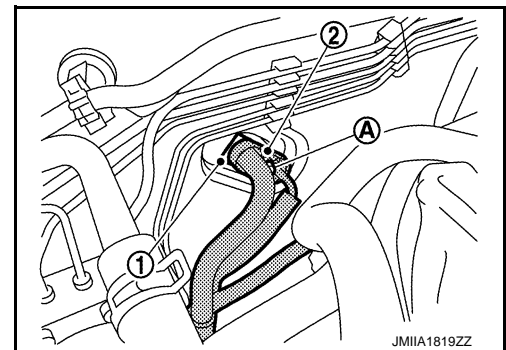

7. Remove instrument panel assembly. Refer to [IP-14, "Removal and Installation"](#).

A/C UNIT ASSEMBLY

< REMOVAL AND INSTALLATION >

8. Remove mounting bolts (A), and then remove knee protector.

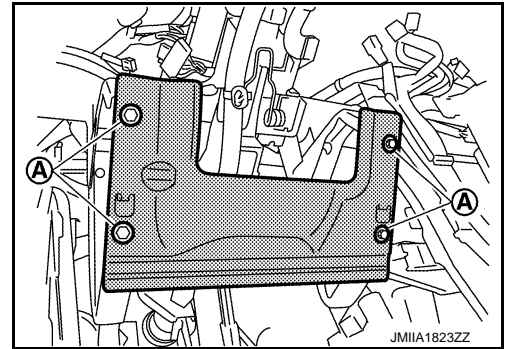

9. Remove mounting bolts and nuts, and then move steering column aside. Refer to [ST-13. "Exploded View"](#).

10. Remove fixing screws (A), and then remove F/B.

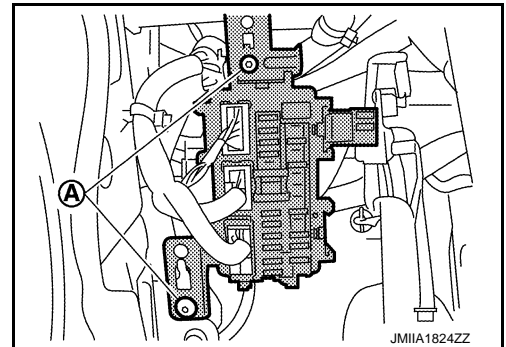

11. Remove mounting bolt (A), and then remove circuit breakers bracket (1).

12. Remove mounting bolt (B), and then remove circuit breaker and relay bracket (2).

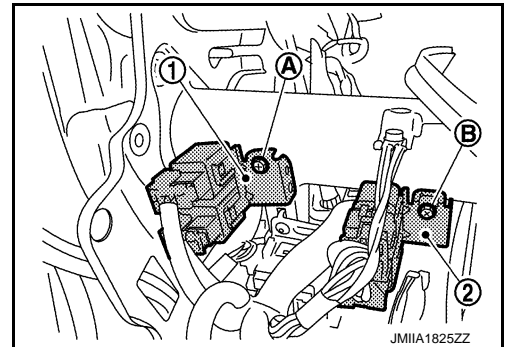

13. Disconnect junction harness connectors. (Driver side)

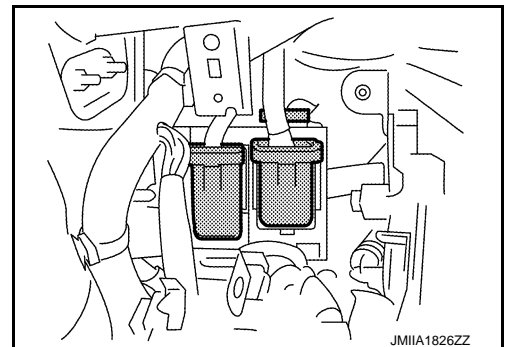

A
B
C
D
E
F
G
H
HA
J
K
L
M
N
O
P

A/C UNIT ASSEMBLY

< REMOVAL AND INSTALLATION >

14. Remove mounting bolt (A), and then remove automatic drive positioner control unit.

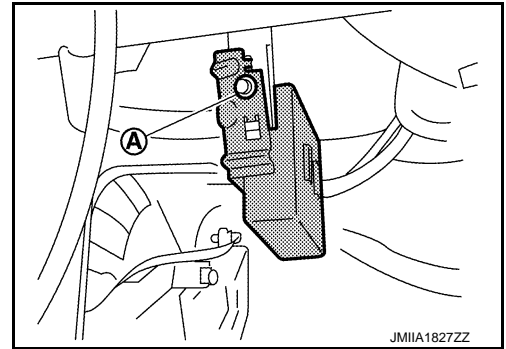

15. Remove harness fixing clip (A), and then disconnect harness connector.

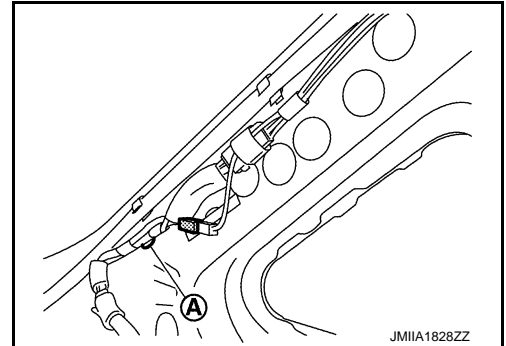

16. Disconnect junction harness connectors. (Passenger side)

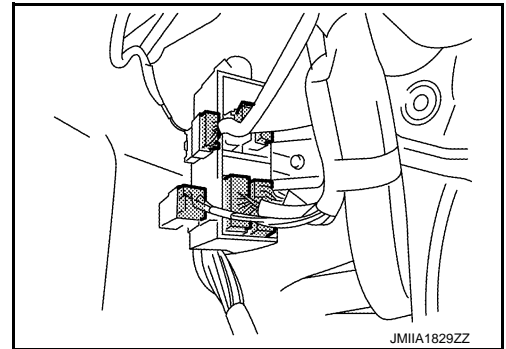

17. Remove mounting nuts (A), and then remove instrument stay. (LH and RH)

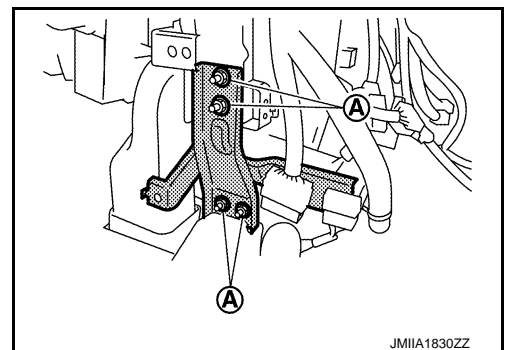

18. Remove harness fixing clip (A).
19. Disconnect drain hose from heater & cooling unit assembly.

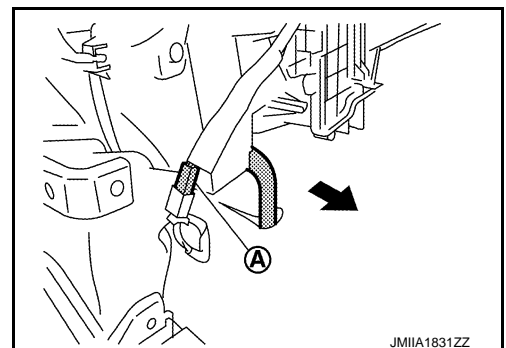

A/C UNIT ASSEMBLY

< REMOVAL AND INSTALLATION >

20. Disconnect front door harness connector. Refer to [DLK-425. "DOOR ASSEMBLY : Removal and Installation"](#). (Passenger side)

21. Disconnect diagnosis sensor unit harness connectors. Refer to [SR-29. "Removal and Installation"](#).

NOTE:

Remove all of harness connectors and clips necessary to allow steering member to be moved. Move main harness aside and secure work space so that steering member can be easily moved.

22. Perform the following operation to move steering member (1).

- Remove steering member mounting bolts (A) from the vehicle.
- Remove steering member mounting bolts (B) and harness fixing clip (C) from heater & cooling unit assembly
- Remove steering member mounting bolt (D) from blower unit assembly

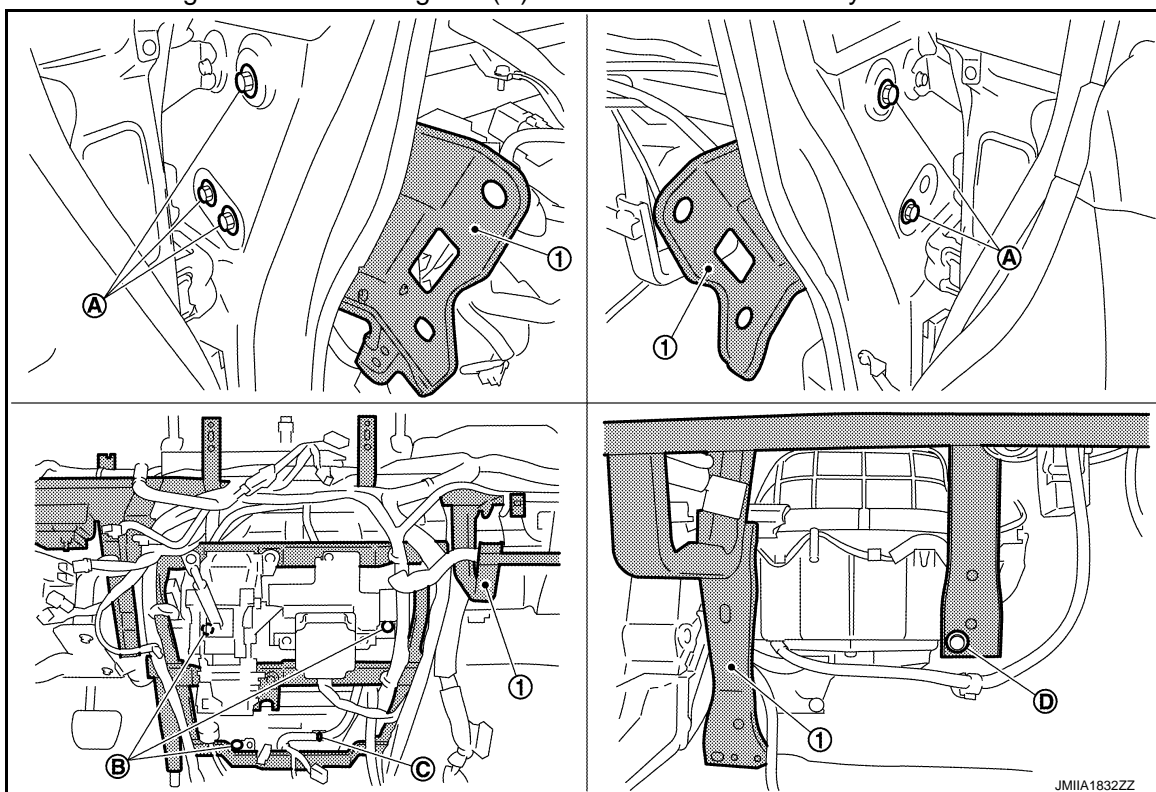

23. Move steering member to secure work space as shown in the figure.

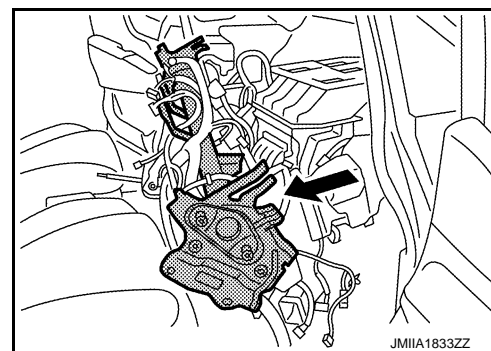

24. Remove front A/C unit assembly from the vehicle.

25. Separate blower unit assembly and heater & cooling unit assembly.

INSTALLATION

Note the following items, and then install in the reverse order of removal.

CAUTION:

- Replace O-rings with new ones. Then apply compressor oil to them when installing.
- Check for leakages when recharging refrigerant. Refer to [HA-18. "Leak Test"](#).

NOTE:

Refer to [CO-9. "Refilling"](#) when filling radiator with engine coolant.

A/C UNIT ASSEMBLY

< REMOVAL AND INSTALLATION >

EVAPORATOR

EVAPORATOR : Removal and Installation

INFOID:000000011324211

CAUTION:

Perform lubricant return operation before each refrigeration system disassembly. However, if a large amount of refrigerant or lubricant is detected, never perform lubricant return operation. Refer to [HA-22, "Perform Lubricant Return Operation"](#).

REMOVAL

1. Use a refrigerant collecting equipment (for HFC-134a) to discharge the refrigerant. Refer to [HA-20, "Recycle Refrigerant"](#).
2. Remove front A/C unit assembly. Refer to [HA-48, "HEATER & COOLING UNIT ASSEMBLY : Removal and Installation"](#).
3. Separate blower unit assembly and heater & cooling unit assembly.
4. Remove foot duct RH. Refer to [VTL-13, "FOOT DUCT : Removal and Installation"](#).
5. Remove front air mix door motor. (Passenger side)
 - Refer to [HAC-151, "Exploded View"](#). (Automatic air conditioning)
 - Refer to [HAC-242, "Exploded View"](#). (Manual air conditioning)
6. Remove fixing screws (A), and then remove heater & cooling unit case cover (1) and filter cover (2) from heater & cooling unit assembly as a set.

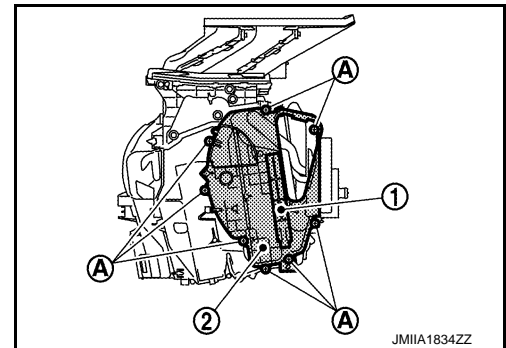

7. Pull out evaporator assembly (2) toward heater & cooling unit assembly (1) to remove.

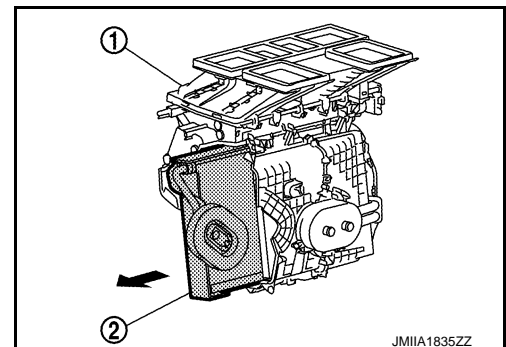

8. Remove intake sensor from evaporator assembly. Refer to [HA-46, "Exploded View"](#).
9. Remove mounting bolts, and then remove evaporator pipe and expansion valve from evaporator assembly as a set. Refer to [HA-46, "Exploded View"](#).

CAUTION:

Cap or wrap the joint of the evaporator, evaporator pipe, and expansion valve with suitable material such as vinyl tape to avoid the entry of air.

INSTALLATION

Note the following items, and then install in the reverse order of removal.

CAUTION:

- Replace O-rings with new ones. Then apply compressor oil to them when installing.
- When install the intake sensor, set the same position before replacement.
- Never rotate the bracket insertion part when removing and installing the intake sensor.
- Perform lubricant adjusting procedure after installing new evaporator. Refer to [HA-22, "Lubricant Adjusting Procedure for Components Replacement Except Compressor"](#).

EVAPORATOR PIPE ASSEMBLY

A/C UNIT ASSEMBLY

< REMOVAL AND INSTALLATION >

EVAPORATOR PIPE ASSEMBLY : Removal and Installation

INFOID:000000011324212

CAUTION:

Perform lubricant return operation before each refrigeration system disassembly. However, if a large amount of refrigerant or lubricant is detected, never perform lubricant return operation. Refer to [HA-22, "Perform Lubricant Return Operation"](#).

REMOVAL

1. Use a refrigerant collecting equipment (for HFC-134a) to discharge the refrigerant. Refer to [HA-20, "Recycle Refrigerant"](#).
2. Remove evaporator assembly. Refer to [HA-52, "EVAPORATOR : Removal and Installation"](#).
3. Remove mounting bolts, and then remove expansion valve from evaporator assembly. Refer to [HA-46, "Exploded View"](#).
4. Remove mounting bolts, and then remove evaporator pipe assembly from evaporator assembly. Refer to [HA-46, "Exploded View"](#).

CAUTION:

Cap or wrap the joint of expansion valve, evaporator pipe assembly, and evaporator with suitable material such as vinyl tape to avoid the entry of air.

INSTALLATION

Note the following items, and then install in the reverse order of removal.

CAUTION:

- Replace O-rings with new ones. Then apply compressor oil to them when installing.
- Check for leakages when recharging refrigerant. Refer to [HA-18, "Leak Test"](#).

HEATER CORE

HEATER CORE : Removal and Installation

INFOID:000000011324213

CAUTION:

Perform lubricant return operation before each refrigeration system disassembly. However, if a large amount of refrigerant or lubricant is detected, never perform lubricant return operation. Refer to [HA-22, "Perform Lubricant Return Operation"](#).

REMOVAL

1. Use a refrigerant collecting equipment (for HFC-134a) to discharge the refrigerant. Refer to [HA-20, "Recycle Refrigerant"](#).
2. Drain engine coolant from cooling system. Refer to [CO-8, "Draining"](#).
3. Remove front A/C unit assembly. Refer to [HA-48, "HEATER & COOLING UNIT ASSEMBLY : Removal and Installation"](#).
4. Separate blower unit assembly and heater & cooling unit assembly.
5. Remove heater pipe grommet. Refer to [HA-46, "Exploded View"](#).
6. Remove fixing screw (A), and then remove fixing pawls.

 : Pawl

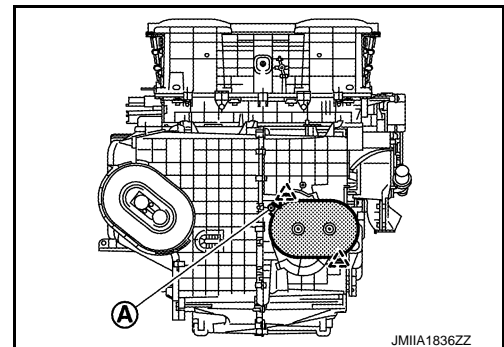

7. Remove heater pipe support from heater & cooling unit assembly.

A/C UNIT ASSEMBLY

< REMOVAL AND INSTALLATION >

8. Remove fixing screws (A), and then remove heater pipe cover.

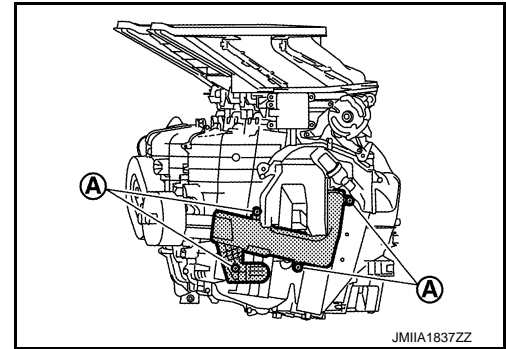

9. Pull out heater core (2) toward heater & cooling unit assembly (1) to remove.

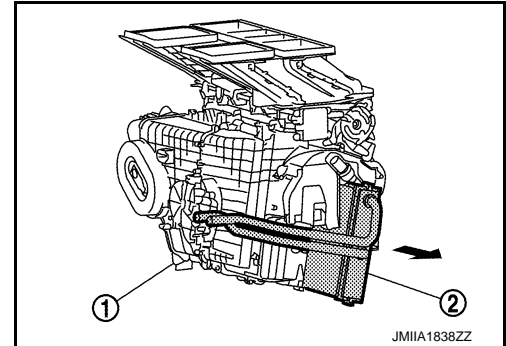

INSTALLATION

Note the following item, and then install in the reverse order of removal.

NOTE:

Refer to [CO-9, "Refilling"](#) when filling radiator with engine coolant.

EXPANSION VALVE

EXPANSION VALVE : Removal and Installation

INFOID:000000011324214

CAUTION:

Perform lubricant return operation before each refrigeration system disassembly. However, if a large amount of refrigerant or lubricant is detected, never perform lubricant return operation. Refer to [HA-22, "Perform Lubricant Return Operation"](#).

REMOVAL

1. Use a refrigerant collecting equipment (for HFC-134a) to discharge the refrigerant. Refer to [HA-20, "Recycle Refrigerant"](#).
2. Disconnect front cooler pipe assembly from expansion valve. Refer to [HA-37, "COOLER PIPE ASSEMBLY : Removal and Installation"](#).
3. Remove mounting bolts, and then remove expansion valve from evaporator assembly. Refer to [HA-46, "Exploded View"](#).

CAUTION:

Cap or wrap the joint of the A/C piping, expansion valve, and evaporator assembly with suitable material such as vinyl tape to avoid the entry of air.

INSTALLATION

Note the following items, and then install in the reverse order of removal.

CAUTION:

- Replace O-rings with new ones. Then apply compressor oil to them when installing.
- Check for leakages when recharging refrigerant. Refer to [HA-18, "Leak Test"](#).

REAR A/C UNIT

< REMOVAL AND INSTALLATION >

REAR A/C UNIT

Exploded View

INFOID:000000011324215

REMOVAL

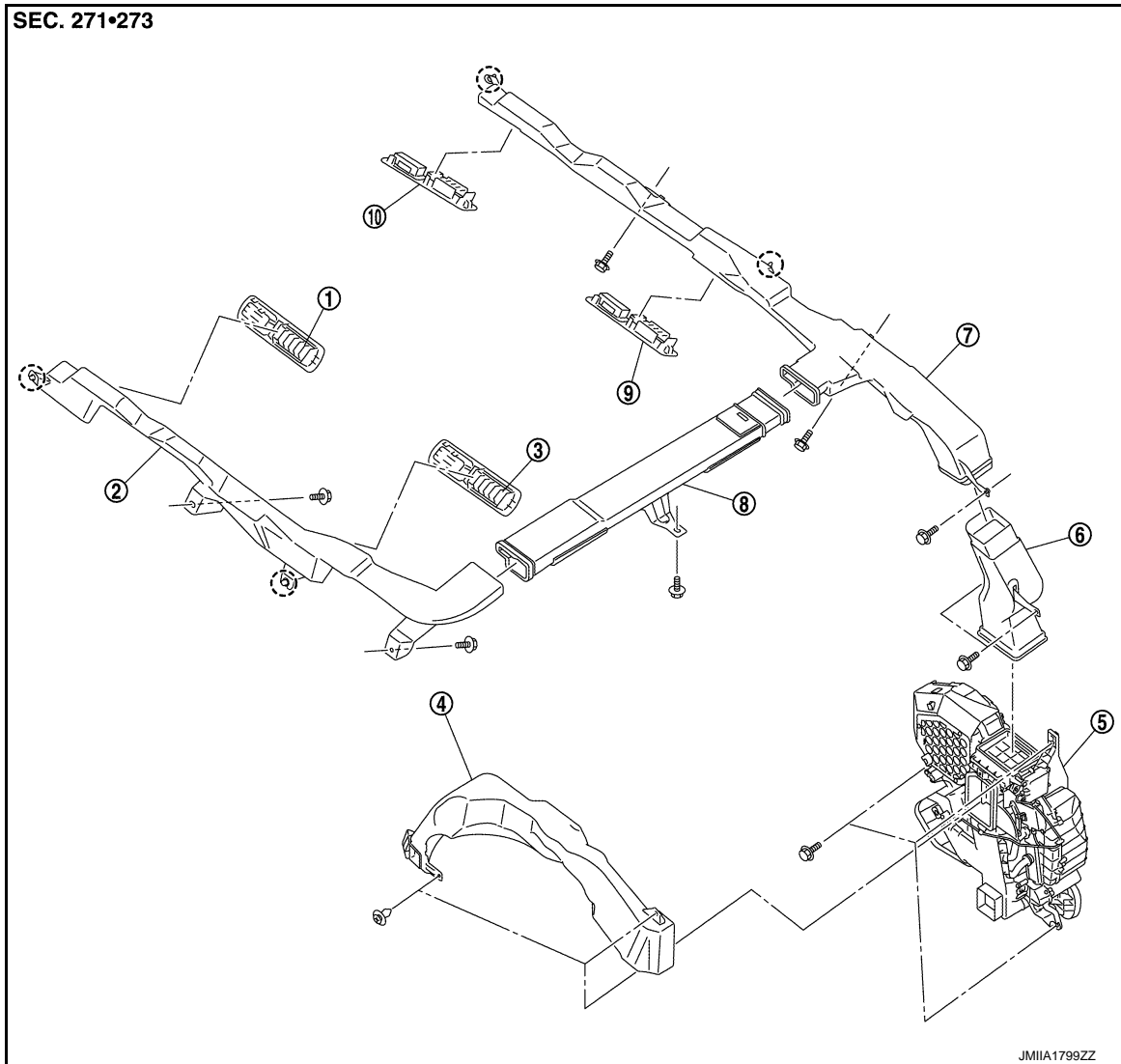

- | | | |
|---------------------------------|---------------------------------|--------------------------------|
| 1. Rear ventilator grille 1 LH | 2. Rear upper ventilator duct 1 | 3. Rear ventilator grille 2 LH |
| 4. Rear foot duct 1 | 5. Rear A/C unit assembly | 6. Rear ventilator pillar duct |
| 7. Rear upper ventilator duct 3 | 8. Rear upper ventilator duct 2 | 9. Rear ventilator grille 2 RH |
| 10. Rear ventilator grille 1 LH | | |

○ : Clip

DISASSEMBLY

A
B
C
D
E
F
G
H
HA
J
K
L
M
N
O
P

REAR A/C UNIT

< REMOVAL AND INSTALLATION >



- | | | |
|--------------------------------|---------------------------------|---------------------------|
| 1. Foot packing | 2. Rear foot duct 2 | 3. Intake sensor |
| 4. Rear heater core | 5. Clamp | 6. Blind cap |
| 7. Sub harness | 8. Rear A/C unit case LH | 9. Drain flange packing |
| 10. Drain flange | 11. Drain flange adapter | 12. Drain packing |
| 13. Rear A/C unit case packing | 14. Rear A/C unit case RH | 15. Sub harness |
| 16. Rear blower motor | 17. Insulator 1 | 18. Insulator 3 |
| 19. Evaporator | 20. Insulator 2 | 21. O-ring |
| 22. Rear A/C unit packing | 23. Rear A/C unit pipe assembly | 24. Rear air mix door |
| 25. Rear mode door | 26. Rear A/C unit grommet | 27. Expansion valve |
| 28. Evaporator pipe assembly | 29. Rear ventilator packing | 30. Rear A/C unit bracket |

⊗ : Always replace after every disassembly.

🔧 : N·m (kg-m, in-lb)

REAR A/C UNIT ASSEMBLY

REAR A/C UNIT ASSEMBLY : Removal and Installation

INFOID:0000000011324216

CAUTION:

Perform lubricant return operation before each refrigeration system disassembly. However, if a large amount of refrigerant or lubricant is detected, never perform lubricant return operation. Refer to [HA-22. "Perform Lubricant Return Operation"](#).

REMOVAL

1. Use a refrigerant collecting equipment (for HFC-134a) to discharge the refrigerant. Refer to [HA-20. "Recycle Refrigerant"](#).
2. Drain engine coolant from cooling system. Refer to [CO-8. "Draining"](#).
3. Remove rear bumper closing. Refer to [EXT-17. "REAR BUMPER CLOSING : Removal and Installation"](#).

REAR A/C UNIT

< REMOVAL AND INSTALLATION >

4. Remove mounting bolt (A) and fixing clamps (B).
5. Disconnect rear cooler pipe assembly 2 from expansion valve.

CAUTION:

Cap or wrap the joint of the A/C piping and expansion valve with suitable material such as vinyl tape to avoid the entry of air.

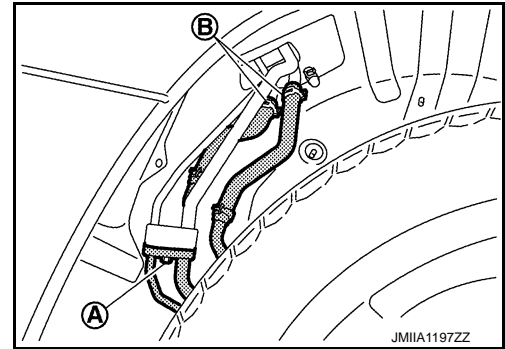

6. Remove luggage side lower finisher RH. Refer to [INT-43. "LUGGAGE SIDE LOWER FINISHER : Removal and Installation"](#).
7. Remove back pillar garnish RH. Refer to [INT-27. "BACK PILLAR GARNISH : Removal and Installation"](#).
8. Remove rear ventilator pillar duct. Refer to [VTL-14. "REAR VENTILATOR DUCT : Removal and Installation"](#).
9. Remove seat belt shoulder bracket RH. Refer to [SB-16. "Exploded View"](#).
10. Disconnect harness connectors (A), and then remove harness fixing clip (B).

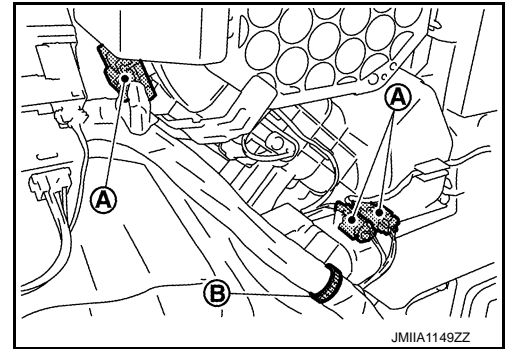

11. Remove mounting bolts, and then remove rear A/C unit assembly from the vehicle. Refer to [HA-55. "Exploded View"](#).

INSTALLATION

Note the following items, and then install in the reverse order of removal.

CAUTION:

- Replace O-rings with new ones. Then apply compressor oil to them when installing.
- Check for leakages when recharging refrigerant. Refer to [HA-18. "Leak Test"](#).

NOTE:

Refer to [CO-9. "Refilling"](#) when filling radiator with engine coolant.

EVAPORATOR

EVAPORATOR : Removal and Installation

INFOID:000000011324217

CAUTION:

Perform lubricant return operation before each refrigeration system disassembly. However, if a large amount of refrigerant or lubricant is detected, never perform lubricant return operation. Refer to [HA-22. "Perform Lubricant Return Operation"](#).

REMOVAL

1. Use a refrigerant collecting equipment (for HFC-134a) to discharge the refrigerant. Refer to [HA-20. "Recycle Refrigerant"](#).
2. Remove rear A/C unit assembly. Refer to [HA-56. "REAR A/C UNIT ASSEMBLY : Removal and Installation"](#).
3. Remove mounting bolt, and then disconnect rear cooler pipe assembly from expansion valve.
CAUTION:
Cap or wrap the joint of the rear A/C piping and expansion valve with suitable material such as vinyl tape to avoid the entry of air.
4. Disassemble rear A/C unit assembly, and then remove evaporator assembly.

REAR A/C UNIT

< REMOVAL AND INSTALLATION >

5. Remove mounting bolts, and then remove evaporator pipe assembly and expansion valve from evaporator assembly as a set. Refer to [HA-55, "Exploded View"](#).

INSTALLATION

Note the following items, and then install in the reverse order of removal.

CAUTION:

- Replace O-rings with new ones. Then apply compressor oil to them when installing.
- Perform lubricant adjusting procedure after installing new evaporator. Refer to [HA-22, "Lubricant Adjusting Procedure for Components Replacement Except Compressor"](#).
- Check for leakages when recharging refrigerant. Refer to [HA-18, "Leak Test"](#).

EVAPORATOR PIPE ASSEMBLY

EVAPORATOR PIPE ASSEMBLY : Removal and Installation

INFOID:000000011324218

CAUTION:

Perform lubricant return operation before each refrigeration system disassembly. However, if a large amount of refrigerant or lubricant is detected, never perform lubricant return operation. Refer to [HA-22, "Perform Lubricant Return Operation"](#).

REMOVAL

1. Use a refrigerant collecting equipment (for HFC-134a) to discharge the refrigerant. Refer to [HA-20, "Recycle Refrigerant"](#).
2. Remove rear A/C unit assembly. Refer to [HA-56, "REAR A/C UNIT ASSEMBLY : Removal and Installation"](#).
3. Remove mounting bolt, and then disconnect rear cooler pipe assembly from expansion valve.
CAUTION:
Cap or wrap the joint of the rear A/C piping and expansion valve with suitable material such as vinyl tape to avoid the entry of air.
4. Remove mounting bolts, and then remove expansion valve from evaporator pipe assembly.
CAUTION:
Cap or wrap the joint of the expansion valve and evaporator pipe assembly with suitable material such as vinyl tape to avoid the entry of air.
5. Disassemble rear A/C unit assembly, and then remove evaporator assembly.
6. Remove mounting bolts, and then remove evaporator pipe assembly from evaporator assembly.

INSTALLATION

Note the following items, and then install in the reverse order of removal.

CAUTION:

- Replace O-rings with new ones. Then apply compressor oil to them when installing.
- Check for leakages when recharging refrigerant. Refer to [HA-18, "Leak Test"](#).

HEATER CORE

HEATER CORE : Removal and Installation

INFOID:000000011324219

CAUTION:

Perform lubricant return operation before each refrigeration system disassembly. However, if a large amount of refrigerant or lubricant is detected, never perform lubricant return operation. Refer to [HA-22, "Perform Lubricant Return Operation"](#).

REMOVAL

1. Use a refrigerant collecting equipment (for HFC-134a) to discharge the refrigerant. Refer to [HA-20, "Recycle Refrigerant"](#).
2. Remove rear A/C unit assembly. Refer to [HA-56, "REAR A/C UNIT ASSEMBLY : Removal and Installation"](#).
3. Remove fixing screws, and then remove rear foot duct 2 from rear A/C unit assembly.
4. Remove heater core from rear A/C unit assembly.

INSTALLATION

Note the following item, and then install in the reverse order of removal.

NOTE:

REAR A/C UNIT

< REMOVAL AND INSTALLATION >

Refer to [CO-9, "Refilling"](#) when filling radiator with engine coolant.

EXPANSION VALVE

EXPANSION VALVE : Removal and Installation

INFOID:0000000011324220

CAUTION:

Perform lubricant return operation before each refrigeration system disassembly. However, if a large amount of refrigerant or lubricant is detected, never perform lubricant return operation. Refer to [HA-22, "Perform Lubricant Return Operation"](#).

REMOVAL

1. Use a refrigerant collecting equipment (for HFC-134a) to discharge the refrigerant. Refer to [HA-20, "Recycle Refrigerant"](#).
2. Remove rear A/C unit assembly. Refer to [HA-56, "REAR A/C UNIT ASSEMBLY : Removal and Installation"](#).
3. Remove mounting bolt, and then disconnect rear cooler pipe assembly from expansion valve.
CAUTION:
Cap or wrap the joint of the rear A/C piping and expansion valve with suitable material such as vinyl tape to avoid the entry of air.
4. Remove mounting bolts, and then disconnect expansion valve from evaporator pipe assembly.
CAUTION:
Cap or wrap the joint of the expansion valve and evaporator pipe assembly with suitable material such as vinyl tape to avoid the entry of air.

INSTALLATION

Note the following items, and then install in the reverse order of removal.

CAUTION:

- Replace O-rings with new ones. Then apply compressor oil to them when installing.
- Check for leakages when recharging refrigerant. Refer to [HA-18, "Leak Test"](#).

A
B
C
D
E
F
G
H
HA
J
K
L
M
N
O
P

SERVICE DATA AND SPECIFICATIONS (SDS)

< SERVICE DATA AND SPECIFICATIONS (SDS)

SERVICE DATA AND SPECIFICATIONS (SDS)

SERVICE DATA AND SPECIFICATIONS (SDS)

Compressor

INFOID:0000000011324221

Model		VALEO THERMAL SYSTEMS JAPAN make DKS-17D
Type		Fixation displacement swash plate
Displacement cm ³ (cu in)/rev	Maximum	175 (10.7)
Direction of rotation		Clockwise (viewed from clutch)
Drive belt		Poly V
Disc to pulley clearance mm (in)	Standard	0.3 – 0.6 (0.012 – 0.024)

Lubricant

INFOID:0000000011324222

Name		A/C System Oil Type S (DH-PS)
Capacity m ^l (US fl oz, Imp fl oz)	Total in system	250 (8.5, 8.8)
	Compressor (service part) charging amount	250 (8.5, 8.8)

Refrigerant

INFOID:0000000011324223

Type		HFC-134a (R-134a)
Capacity kg (lb)		0.9 (1.98)

Engine Idling Speed

INFOID:0000000011324224

Refer to [EC-513, "Idle Speed"](#).

Belt Tension

INFOID:0000000011324225

Refer to [EM-15, "Tension Adjustment"](#).