

SECTION **DEF**
DEFOGGER

A
B
C

CONTENTS

D
E

PRECAUTION	3	DIAGNOSIS AND REPAIR WORK FLOW	21	F
PRECAUTIONS	3	Work Flow	21	
Precaution for Supplemental Restraint System (SRS) "AIR BAG" and "SEAT BELT PRE-TENSIONER"	3	DTC/CIRCUIT DIAGNOSIS	22	G
Precaution for Procedure without Cowl Top Cover.....	3	REAR WINDOW DEFOGGER SWITCH	22	
Precautions For Xenon Headlamp Service	3	WITH AUTO A/C	22	H
Precautions for Removing Battery Terminal	4	WITH AUTO A/C : Component Function Check	22	
SYSTEM DESCRIPTION	5	WITH AUTO A/C : Diagnosis Procedure	22	
COMPONENT PARTS	5	WITH MANUAL A/C	23	I
Component Parts Location	5	WITH MANUAL A/C : Component Function Check	23	
Rear window defogger	6	WITH MANUAL A/C : Diagnosis Procedure	23	J
Door mirror defogger	6	REAR WINDOW DEFOGGER RELAY	25	
SYSTEM	7	Component Function Check	25	K
System Description	7	Diagnosis Procedure	25	
Circuit Diagram	8	Component Inspection	26	
DIAGNOSIS SYSTEM (BCM)	9	REAR WINDOW DEFOGGER	27	DEF
COMMON ITEM	9	Component Function Check	27	
COMMON ITEM : CONSULT Function (BCM - COMMON ITEM)	9	Diagnosis Procedure	27	
REAR WINDOW DEFOGGER	10	DOOR MIRROR DEFOGGER	29	M
REAR WINDOW DEFOGGER : CONSULT Function (BCM - REAR DEFOGGER)	11	Component Function Check	29	
Diagnosis Procedure	11	Diagnosis Procedure	29	
ECU DIAGNOSIS INFORMATION	12	DRIVER SIDE DOOR MIRROR DEFOGGER ...	30	N
BCM	12	Component Function Check	30	
List of ECU Reference	12	Diagnosis Procedure	30	O
WIRING DIAGRAM	13	PASSENGER SIDE DOOR MIRROR DEFOGGER	31	
REAR WINDOW DEFOGGER SYSTEM	13	Component Function Check	31	P
Wiring Diagram	13	Diagnosis Procedure	31	
BASIC INSPECTION	21	REAR WINDOW DEFOGGER FEEDBACK SIGNAL	32	
		WITH AUTO A/C	32	
		WITH AUTO A/C : Component Function Check	32	

WITH AUTO A/C : Diagnosis Procedure	32	DOOR MIRROR DEFOGGER DOES NOT OPERATE	38
WITH MANUAL A/C	33	BOTH SIDES	38
WITH MANUAL A/C : Component Function Check	33	BOTH SIDES : Description	38
WITH MANUAL A/C : Diagnosis Procedure	33	BOTH SIDES : Diagnosis Procedure	38
SYMPTOM DIAGNOSIS	35	DRIVER SIDE	38
REAR WINDOW DEFOGGER DOES NOT OPERATE	35	DRIVER SIDE : Description	38
Description	35	DRIVER SIDE : Diagnosis Procedure	38
Diagnosis Procedure	35	PASSENGER SIDE	38
REAR WINDOW DEFOGGER AND DOOR MIRROR DEFOGGERS DO NOT OPERATE ...	36	PASSENGER SIDE : Description	38
Description	36	PASSENGER SIDE : Diagnosis Procedure	38
Diagnosis Procedure	36	REAR WINDOW DEFOGGER INDICATOR DOES NOT ILLUMINATE	40
REAR WINDOW DEFOGGER DOES NOT OPERATE BUT BOTH DOOR MIRROR DEFOGGERS OPERATE	37	Diagnosis Procedure	40
Description	37	REMOVAL AND INSTALLATION	41
Diagnosis Procedure	37	FILAMENT	41
		Inspection and Repair	41

PRECAUTIONS

< PRECAUTION >

PRECAUTION

PRECAUTIONS

Precaution for Supplemental Restraint System (SRS) "AIR BAG" and "SEAT BELT PRE-TENSIONER"

INFOID:000000012409519

The Supplemental Restraint System such as "AIR BAG" and "SEAT BELT PRE-TENSIONER", used along with a front seat belt, helps to reduce the risk or severity of injury to the driver and front passenger for certain types of collision. This system includes seat belt switch inputs and dual stage front air bag modules. The SRS system uses the seat belt switches to determine the front air bag deployment, and may only deploy one front air bag, depending on the severity of a collision and whether the front occupants are belted or unbelted. Information necessary to service the system safely is included in the "SRS AIR BAG" and "SEAT BELT" of this Service Manual.

WARNING:

Always observe the following items for preventing accidental activation.

- To avoid rendering the SRS inoperative, which could increase the risk of personal injury or death in the event of a collision that would result in air bag inflation, all maintenance must be performed by an authorized NISSAN/INFINITI dealer.
- Improper maintenance, including incorrect removal and installation of the SRS, can lead to personal injury caused by unintentional activation of the system. For removal of Spiral Cable and Air Bag Module, see "SRS AIR BAG".
- Never use electrical test equipment on any circuit related to the SRS unless instructed to in this Service Manual. SRS wiring harnesses can be identified by yellow and/or orange harnesses or harness connectors.

PRECAUTIONS WHEN USING POWER TOOLS (AIR OR ELECTRIC) AND HAMMERS

WARNING:

Always observe the following items for preventing accidental activation.

- When working near the Air Bag Diagnosis Sensor Unit or other Air Bag System sensors with the ignition ON or engine running, never use air or electric power tools or strike near the sensor(s) with a hammer. Heavy vibration could activate the sensor(s) and deploy the air bag(s), possibly causing serious injury.
- When using air or electric power tools or hammers, always switch the ignition OFF, disconnect the battery, and wait at least 3 minutes before performing any service.

Precaution for Procedure without Cowl Top Cover

INFOID:000000012409520

When performing the procedure after removing cowl top cover, cover the lower end of windshield with urethane, etc to prevent damage to windshield.

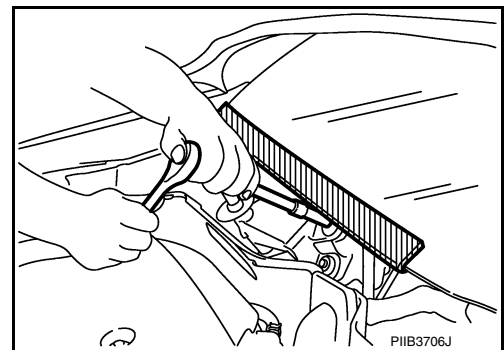

Precautions For Xenon Headlamp Service

INFOID:000000012409521

WARNING:

Comply with the following warnings to prevent any serious accident.

- Disconnect the battery cable (negative terminal) or the power supply fuse before installing, removing, or touching the xenon headlamp (bulb included). The xenon headlamp contains high-voltage generated parts.
- Never work with wet hands.
- Check the xenon headlamp ON-OFF status after assembling it to the vehicle. Never turn the xenon headlamp ON in other conditions. Connect the power supply to the vehicle-side connector.

A
B
C
D
E
F
G
H
I
J
K
DEF
M
N
O
P

PRECAUTIONS

< PRECAUTION >

(Turning it ON outside the lamp case may cause fire or visual impairments.)

- Never touch the bulb glass immediately after turning it OFF. It is extremely hot.

CAUTION:

Comply with the following cautions to prevent any error and malfunction.

- Install the xenon bulb securely. (Insufficient bulb socket installation may melt the bulb, the connector, the housing, etc. by high-voltage leakage or corona discharge.)
- Never perform HID circuit inspection with a tester.
- Never touch the xenon bulb glass with hands. Never put oil and grease on it.
- Dispose of the used xenon bulb after packing it in thick vinyl without breaking it.
- Never wipe out dirt and contamination with organic solvent (thinner, gasoline, etc.).

Precautions for Removing Battery Terminal

INFOID:000000013042688

When disconnecting the battery terminal, pay attention to the following.

- Always use a 12V battery as power source.
- Never disconnect battery terminal while engine is running.
- When removing the 12V battery terminal, turn OFF the ignition switch and wait at least 30 seconds.
- For vehicles with the engine listed below, remove the battery terminal after a lapse of the specified time:

D4D engine	: 20 minutes	YS23DDT	: 4 minutes
HRA2DDT	: 12 minutes	YS23DDTT	: 4 minutes
K9K engine	: 4 minutes	ZD30DDTi	: 60 seconds
M9R engine	: 4 minutes	ZD30DDTT	: 60 seconds
R9M engine	: 4 minutes		
V9X engine	: 4 minutes		
YD25DDTi	: 2 minutes		

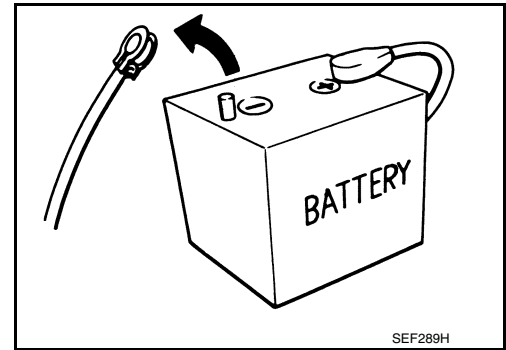

NOTE:

ECU may be active for several tens of seconds after the ignition switch is turned OFF. If the battery terminal is removed before ECU stops, then a DTC detection error or ECU data corruption may occur.

- After high-load driving, if the vehicle is equipped with the V9X engine, turn the ignition switch OFF and wait for at least 15 minutes to remove the battery terminal.

NOTE:

- Turbocharger cooling pump may operate in a few minutes after the ignition switch is turned OFF.
- Example of high-load driving
 - Driving for 30 minutes or more at 140 km/h (86 MPH) or more.
 - Driving for 30 minutes or more on a steep slope.
- For vehicles with the 2-batteries, be sure to connect the main battery and the sub battery before turning ON the ignition switch.

NOTE:

If the ignition switch is turned ON with any one of the terminals of main battery and sub battery disconnected, then DTC may be detected.

- After installing the 12V battery, always check "Self Diagnosis Result" of all ECUs and erase DTC.

NOTE:

The removal of 12V battery may cause a DTC detection error.

COMPONENT PARTS

< SYSTEM DESCRIPTION >

SYSTEM DESCRIPTION

COMPONENT PARTS

Component Parts Location

INFOID:000000012409523

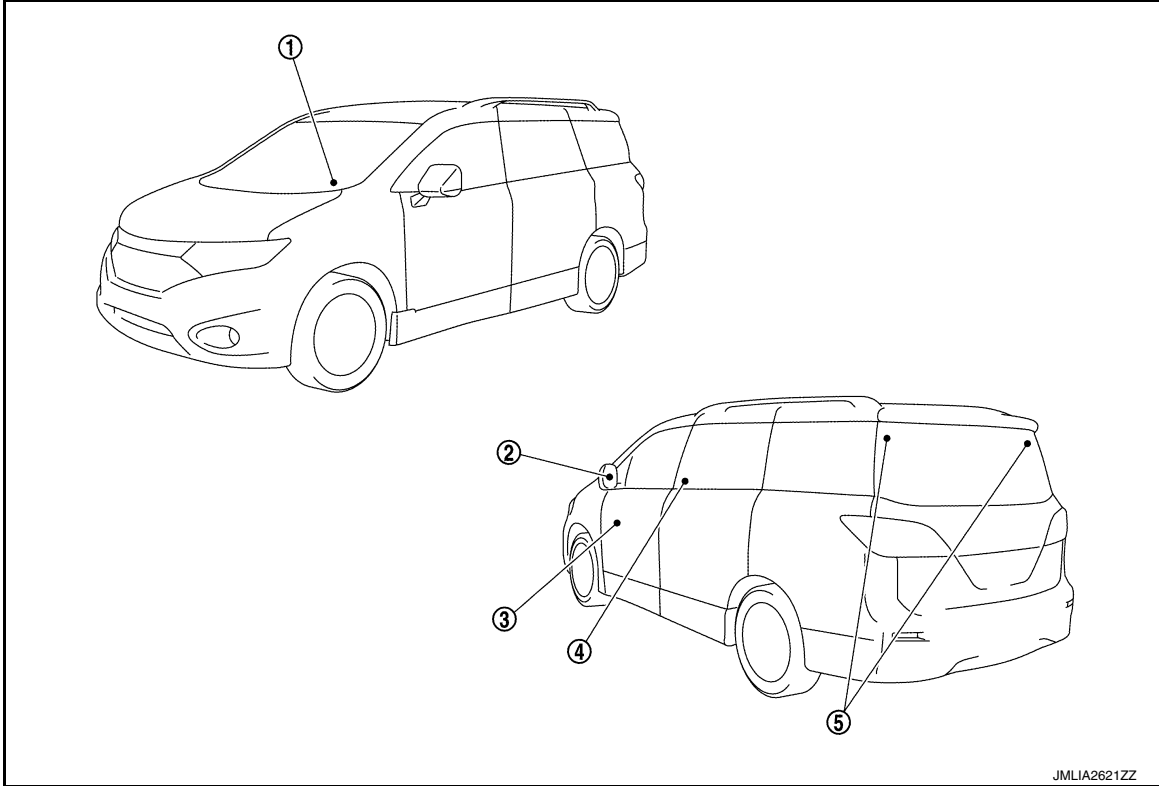

No.	Component	Function
1.	BCM	<ul style="list-style-type: none"> • Detects rear window defogger switch signal then turns rear window defogger relay ON. • Performs the timer control of rear window defogger and door mirror defogger*3. Refer to BCS-5, "BODY CONTROL SYSTEM : Component Parts Location" for detailed installation location.
2.	Door mirror defogger*3	Refer to DEF-6, "Door mirror defogger" .
3.	Rear window defogger relay (built in fuse block J/B)	Operates the rear window defogger and door mirror defogger*3 with BCM control.
4.	<ul style="list-style-type: none"> • A/C auto amp.*1 • A/C amp.*2 (Rear window defogger switch)	<ul style="list-style-type: none"> • The rear window defogger switch is installed. • Rear window defogger and door mirror defogger*3 are operated by turning the rear window defogger switch ON. • The indicator lamp in the rear window defogger switch illuminates when the rear window defogger is operating. Refer to HAC-9, "Component Parts Location" for detailed installation location.
5.	Rear window defogger connector (Rear window defogger)	Refer to DEF-6, "Rear window defogger" .

*1: With auto A/C

*2: With manual A/C

*3: For models with door mirror defogger

COMPONENT PARTS

< SYSTEM DESCRIPTION >

Rear window defogger

INFOID:000000012409524

Heats the heating wire with the power supply from the rear window defogger relay to prevent the rear window from fogging up.

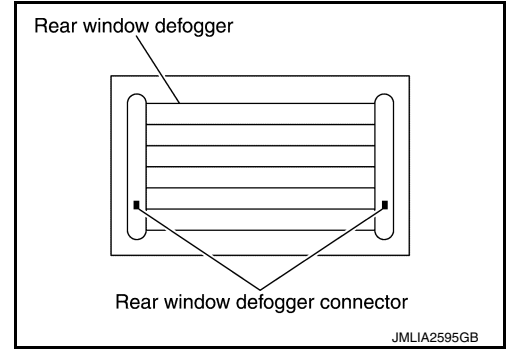

Door mirror defogger

INFOID:000000012409525

Heats the heating wire with the power supply from the rear window defogger relay to prevent the door mirror from fogging up.

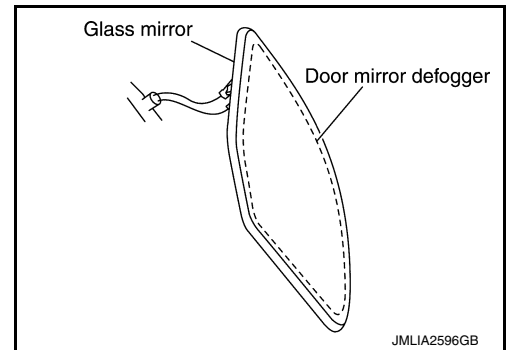

SYSTEM

< SYSTEM DESCRIPTION >

SYSTEM

System Description

INFOID:000000012409526

SYSTEM DIAGRAM

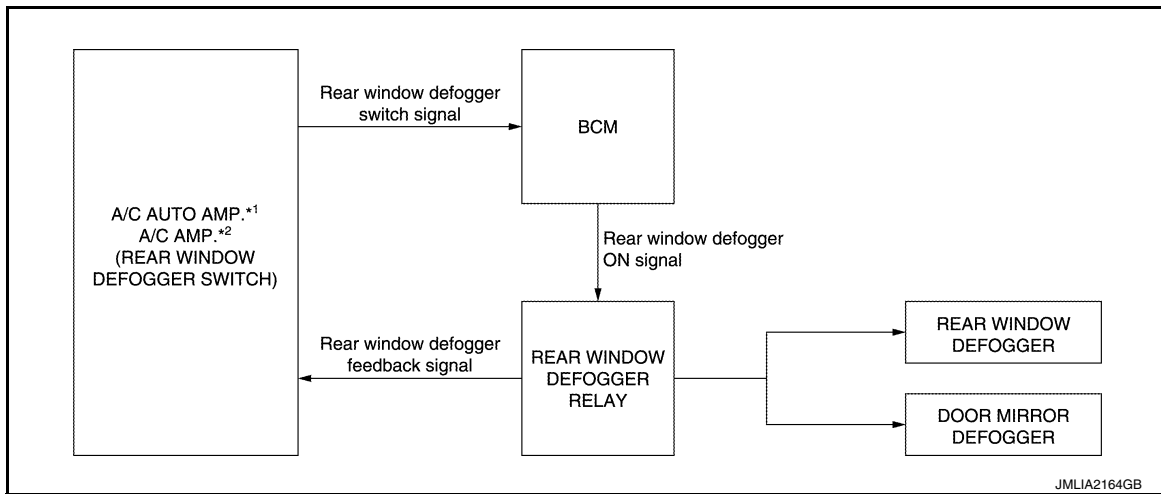

*1: With auto A/C

*2: With manual A/C

OPERATION DESCRIPTION

- When BCM receives rear window defogger switch signal, BCM transmits rear window defogger ON signal to rear window defogger relay (integrated in fuse block J/B) for approximately 15 minutes.
- When rear window defogger relay (integrated in fuse block J/B) turns ON, power supply is supplied to rear window defogger and door mirror defogger (For models with door mirror defogger).
- When rear window defogger and door mirror defogger (For models with door mirror defogger) are operated, rear window defogger feedback signal is transmitted to A/C auto amp.*1 or A/C amp.*2, and then indicator lamp of rear window defogger switch is turned ON.

*1: With auto A/C

*2: With manual A/C

TIMER FUNCTION

- BCM transmits rear window defogger ON signal to rear window defogger relay (integrated in fuse block J/B) for approximately 15 minutes when rear window defogger switch is turned ON while ignition switch is ON.
- Timer is cancelled when rear window defogger switch is pressed again during timer operation. BCM stops the output of rear window defogger ON signal. The same reaction also occurs during timer operation when ignition switch is turned OFF.

A
B
C
D
E
F
G
H
I
J
K
DEF
M
N
O
P

SYSTEM

< SYSTEM DESCRIPTION >

Circuit Diagram

INFOID:000000012409527

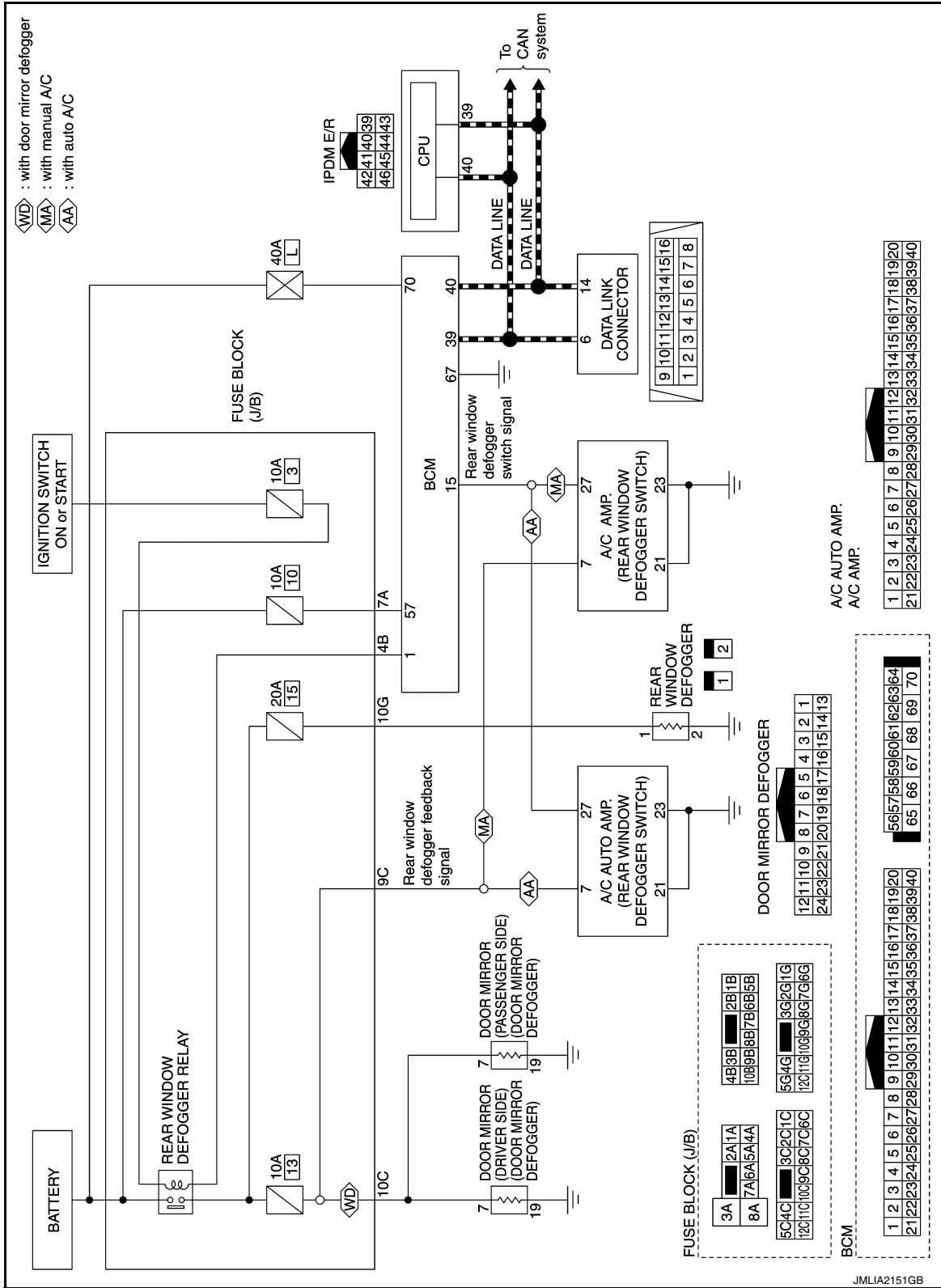

DIAGNOSIS SYSTEM (BCM)

< SYSTEM DESCRIPTION >

DIAGNOSIS SYSTEM (BCM)

COMMON ITEM

COMMON ITEM : CONSULT Function (BCM - COMMON ITEM)

INFOID:000000013042951

APPLICATION ITEM

CONSULT performs the following functions via CAN communication with BCM.

Diagnosis mode	Function Description
Work Support	Changes the setting for each system function.
Self Diagnostic Result	Displays the diagnosis results judged by BCM.
CAN Diag Support Monitor	Monitors the reception status of CAN communication viewed from BCM.
Data Monitor	The BCM input/output signals are displayed.
Active Test	The signals used to activate each device are forcibly supplied from BCM.
Ecu Identification	The BCM part number is displayed.
Configuration	<ul style="list-style-type: none"> Read and save the vehicle specification. Write the vehicle specification when replacing BCM.

SYSTEM APPLICATION

BCM can perform the following functions for each system.

NOTE:

It can perform the diagnosis modes except the following for all sub system selection items.

×: Applicable item

System	Sub system selection item	Diagnosis mode		
		Work Support	Data Monitor	Active Test
Door lock	DOOR LOCK	×	×	×
Rear window defogger	REAR DEFOGGER		×	×
Warning chime	BUZZER		×	×
Interior room lamp control system	INT LAMP	×	×	×
Exterior lamp	HEAD LAMP	×	×	×
Wiper and washer	WIPER	×	×	×
Turn signal and hazard warning lamps	FLASHER	×	×	×
Air conditioning control system	AIR CONDITONER		×	×*
<ul style="list-style-type: none"> Intelligent Key system Engine start system 	INTELLIGENT KEY	×	×	×
Combination switch	COMB SW		×	
Body control system	BCM	×		
NVIS	IMMU	×	×	×
Interior room lamp battery saver	BATTERY SAVER	×	×	×
Back door open	TRUNK		×	
Vehicle security system	THEFT ALM	×	×	×
RAP system	RETAINED PWR		×	
Signal buffer system	SIGNAL BUFFER		×	×
TPMS	AIR PRESSURE MONITOR	×	×	×

NOTE:

*: For models with automatic air conditioning control system, this diagnosis mode is not used.

FREEZE FRAME DATA (FFD)

The BCM records the following vehicle condition at the time a particular DTC is detected, and displays on CONSULT.

DIAGNOSIS SYSTEM (BCM)

< SYSTEM DESCRIPTION >

CONSULT screen item	Indication/Unit	Description	
Vehicle Speed	km/h	Vehicle speed of the moment a particular DTC is detected	
Odo/Trip Meter	km	Total mileage (Odometer value) of the moment a particular DTC is detected	
Vehicle Condition	SLEEP>LOCK	Power position status of the moment a particular DTC is detected*	While turning BCM status from low power consumption mode to normal mode [Power supply position is OFF (LOCK)]
	SLEEP>OFF		While turning BCM status from low power consumption mode to normal mode [Power supply position is OFF (OFF)]
	LOCK>ACC		While turning power supply position from OFF (LOCK) to ACC
	ACC>ON		While turning power supply position from ACC to ON
	RUN>ACC		While turning power supply position from RUN to ACC (Except emergency stop operation)
	CRANK>RUN		While turning power supply position from CRANK to RUN
	RUN>URGENT		While turning power supply position from RUN to ACC (Emergency stop operation)
	ACC>OFF		While turning power supply position from ACC to OFF (OFF)
	OFF>LOCK		While turning power supply position from OFF (OFF) to OFF (LOCK)
	OFF>ACC		While turning power supply position from OFF (OFF) to ACC
	ON>CRANK		While turning power supply position from ON to CRANK
	OFF>SLEEP		While turning BCM status from normal mode [Power supply position is OFF (OFF)] to low power consumption mode
	LOCK>SLEEP		While turning BCM status from normal mode [Power supply position is OFF (LOCK)] to low power consumption mode
	LOCK		Power supply position is OFF (LOCK)
	OFF		Power supply position is OFF (OFF)
	ACC		Power supply position is ACC
	ON		Power supply position is ON
	ENGINE RUN		Power supply position is RUN
CRANKING	Power supply position is CRANK		
IGN Counter	0 - 39	The number of times that ignition switch is turned ON after DTC is detected <ul style="list-style-type: none"> • The number is 0 when a malfunction is detected now. • The number increases like 1 → 2 → 3...38 → 39 after returning to the normal condition whenever ignition switch OFF → ON. • The number is fixed to 39 until the self-diagnosis results are erased if it is over 39. 	

NOTE:

*: Refer to the following for details of the power supply position.

- OFF (OFF, LOCK): Ignition switch OFF
- ACC: Ignition switch ACC
- IGN: Ignition switch ON with engine stopped
- RUN: Ignition switch ON with engine running
- CRANK: At engine cranking

Power supply position shifts to "OFF (LOCK)" from "OFF (OFF)", when ignition switch is in the OFF position, shift position is in the P position, and any of the following conditions are met.

- Closing door
- Opening door
- Door is locked using door request switch
- Door is locked using Intelligent Key

The power supply position shifts to "ACC" when the push-button ignition switch (push switch) is pushed at "OFF (LOCK)".

REAR WINDOW DEFOGGER

DIAGNOSIS SYSTEM (BCM)

< SYSTEM DESCRIPTION >

REAR WINDOW DEFOGGER : CONSULT Function (BCM - REAR DEFOGGER)

INFOID:000000012409529

DATA MONITOR

NOTE:

The following table includes information (items) inapplicable to this vehicle. For information (items) applicable to this vehicle, refer to CONSULT display items.

Monitor Item	Description
REAR DEF SW	Displays "Press (ON)/other (OFF)" status determined with the rear window defogger switch.
PUSH SW	Indicates [ON/OFF] condition of push switch.

ACTIVE TEST

Test Item	Description
REAR DEFOGGER	Rear window defogger operates when ON on CONSULT screen is touched.

A
B
C
D
E
F
G
H
I
J
K
DEF
M
N
O
P

BCM

< ECU DIAGNOSIS INFORMATION >

ECU DIAGNOSIS INFORMATION

BCM

List of ECU Reference

INFOID:000000012409530

ECU	Reference
BCM	BCS-41. "Reference Value"
	BCS-63. "Fail-safe"
	BCS-63. "DTC Inspection Priority Chart"
	BCS-64. "DTC Index"

REAR WINDOW DEFOGGER SYSTEM

< WIRING DIAGRAM >

WIRING DIAGRAM

REAR WINDOW DEFOGGER SYSTEM

Wiring Diagram

INFOID:000000012409531

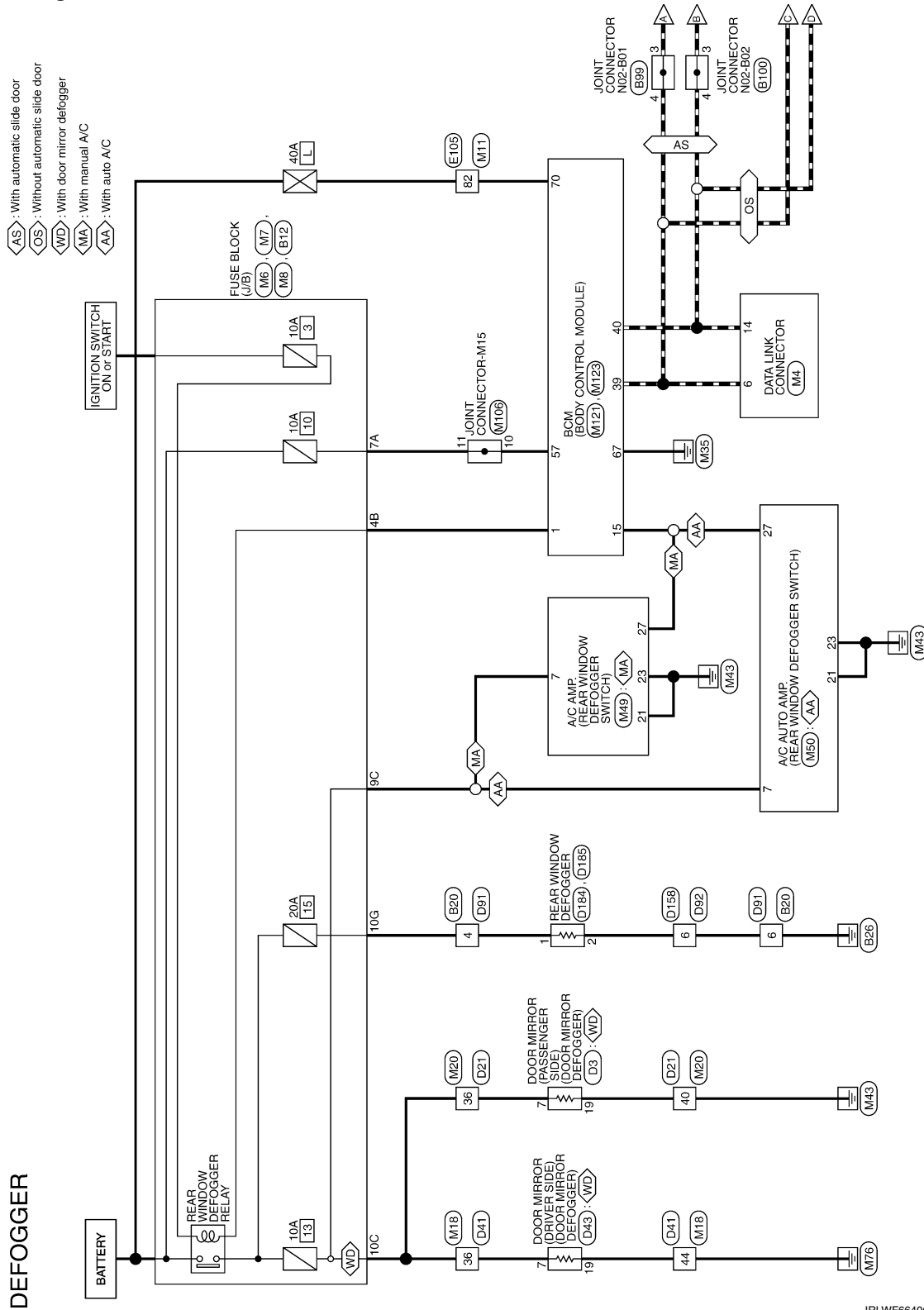

2015/09/04

JRLWF6640GB

REAR WINDOW DEFOGGER SYSTEM

< WIRING DIAGRAM >

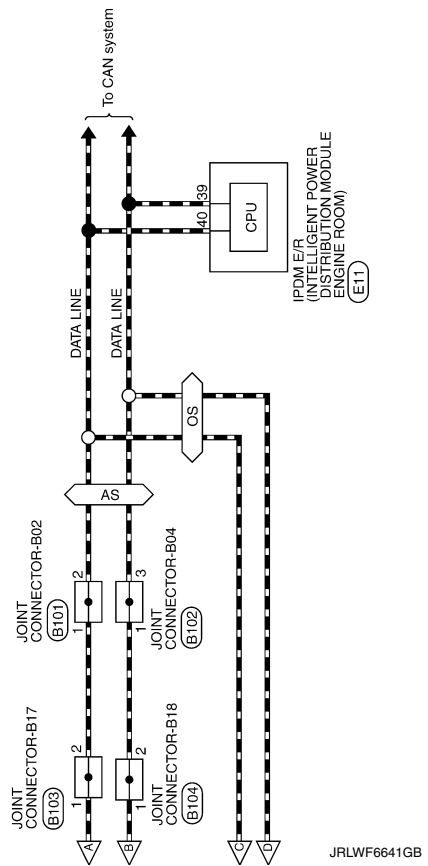



REAR WINDOW DEFOGGER SYSTEM

< WIRING DIAGRAM >



DEFOGGER

Connector No.	B12
Connector Name	FUSE BLOCK (J/B)
Connector Type	NS2J28K-CS



Terminal No.	Color Of Wire	Signal Name [Specification]
10G	Y	-
12G	V	-
2G	P	-
4G	P	-
5G	W	-

Connector No.	B20
Connector Name	WIRE TO WIRE
Connector Type	M05MW-LC



Terminal No.	Color Of Wire	Signal Name [Specification]
1	L	- [With automatic back door]
2	B	- [Without automatic back door]
3	BR	- [With automatic back door]
4	Y	- [Without automatic back door]
5	V	-
6	B	-

Connector No.	B99
Connector Name	JOINT CONNECTOR NO2-B01
Connector Type	TK04FW-J

Terminal No.	Color Of Wire	Signal Name [Specification]
2	W	-
3	L	-
4	L	-

Connector No.	B100
Connector Name	JOINT CONNECTOR NO2-B02
Connector Type	TK04FW-J

Terminal No.	Color Of Wire	Signal Name [Specification]
2	B	-
3	P	-
4	P	-

Connector No.	B101
Connector Name	JOINT CONNECTOR-B02
Connector Type	TK04FW-J

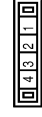

Terminal No.	Color Of Wire	Signal Name [Specification]
1	L	-
2	L	-
3	L	-
4	L	-

Connector No.	B102
Connector Name	JOINT CONNECTOR-B04
Connector Type	TK04FW-J

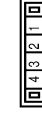

Terminal No.	Color Of Wire	Signal Name [Specification]
1	P	-
2	P	-
3	P	-
4	P	-

Connector No.	B103
Connector Name	JOINT CONNECTOR-B17
Connector Type	TK04FW-J

Terminal No.	Color Of Wire	Signal Name [Specification]
1	L	-
2	L	-
3	L	-

Connector No.	B104
Connector Name	JOINT CONNECTOR-B18
Connector Type	TK04FW-J

Terminal No.	Color Of Wire	Signal Name [Specification]
1	P	-
2	P	-
3	P	-

A
B
C
D
E
F
G
H
I
J
K
DEF
M
N
O
P

REAR WINDOW DEFOGGER SYSTEM

< WIRING DIAGRAM >

DEFOGGER

Connector No.	D33
Connector Name	DOOR MIRROR (PASSENGER SIDE)
Connector Type	TH24MW-NH



Terminal No.	Color Of Wire	Signal Name [Specification]
1	L	-
5	W	-
6	R	-
7	P	-
10	W	-
11	G	-
12	R	-
13	Y	-
17	SHIELD	-
18	B	-
19	B	-
20	LG	-
21	R	-
22	W	-
23	GR	-

Connector No.	D21
Connector Name	WIRE TO WIRE
Connector Type	TH40FW-CS15



Terminal No.	Color Of Wire	Signal Name [Specification]
7	B	-
8	V	-
9	BR	- [With manual A/C]
9	W	- [With auto A/C]

Terminal No.	Color Of Wire	Signal Name [Specification]
10	LG	-
11	GR	-
12	BR	-
14	R	- [Without BOSE system]
14	R	- [With BOSE system]
15	L	-
15	W	- [Without BOSE system]
15	W	- [With BOSE system]
16	P	-
17	GR	-
18	R	-
19	W	-
21	R	-
22	B	-
23	W	-
24	SHIELD	-
25	Y	-
26	L	-
36	P	-
37	G	-
38	W	-
39	LG	-
40	B	-
41	GR	-
42	G	-
43	R	-
45	G	-
46	GR	-
50	W	-
51	W	-
52	C	-
52	SHIELD	-
54	B	-
55	W	-

Connector No.	D41
Connector Name	WIRE TO WIRE
Connector Type	TH40FW-CS15

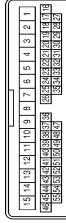

Terminal No.	Color Of Wire	Signal Name [Specification]
2	V	-
3	SP	-
4	Y	-
5	BR	-
6	L	-
7	Y	-
8	GR	-
9	G	- [With manual A/C]
9	R	- [With auto A/C]
10	Y	-
11	BR	-
12	LG	-
13	W	-
14	B	-
15	L	- [Without BOSE system]
15	W	- [With BOSE system]
16	G	-
17	R	-
18	G	-
19	P	-
20	W	-
21	GR	-
22	P	-
23	R	-
24	B	-
25	SHIELD	-
27	R	-
28	P	-
29	GR	-
30	P	-
31	W	-
32	G	-
33	P	-
34	W	-
35	G	-
36	P	-
37	G	-
38	W	-
39	LG	-
40	GR	-
41	GR	-
42	G	-
43	R	-
44	B	-
45	G	-
45	Y	- [Without around view monitor]
45	G	- [With around view monitor]

Terminal No.	Color Of Wire	Signal Name [Specification]
46	GR	- [Without around view monitor]
46	GR	- [With around view monitor]
47	GR	-
48	R	-
49	R	-
50	G	- [With automatic drive positioner]
50	W	- [Without automatic drive positioner]
51	P	- [With automatic drive positioner]
51	R	- [Without automatic drive positioner]
52	G	- [With automatic drive positioner]
52	W	- [Without automatic drive positioner]
53	SHIELD	-
54	B	-
55	W	-

Connector No.	D43
Connector Name	DOOR MIRROR (DRIVER SIDE)
Connector Type	TH24MW-NH



Terminal No.	Color Of Wire	Signal Name [Specification]
5	W	-
5	M	-
6	R	-
7	P	-
10	G	-
11	GR	-
12	P	-
13	Y	-
17	SHIELD	-
18	B	-
19	B	-
20	LG	-
21	P	-
22	R	-
23	W	-
24	G	-

REAR WINDOW DEFOGGER SYSTEM

< WIRING DIAGRAM >

DEFOGGER

Connector No.	D191
Connector Name	WIRE TO WIRE
Connector Type	M08FW-LC



Terminal No.	Color Of Wire	Signal Name [Specification]
1	G	- [With automatic back door]
2	B	- [Without automatic back door]
3	B/W	- [With automatic back door]
4	Y	- [Without automatic back door]
5	R	-
6	B	-

Connector No.	D192
Connector Name	WIRE TO WIRE
Connector Type	M08FW-LC



Terminal No.	Color Of Wire	Signal Name [Specification]
1	B/W	- [With automatic back door]
2	B	- [Without automatic back door]
3	G	- [With automatic back door]
5	R	- [Without automatic back door]
6	B	-

Connector No.	D158
Connector Name	WIRE TO WIRE
Connector Type	M08FW-LC



Terminal No.	Color Of Wire	Signal Name [Specification]
1	GR	- [Without automatic back door]
2	B	- [With automatic back door]
3	BR	- [With automatic back door]
5	SB	- [Without automatic back door]
6	B	-

Connector No.	D184
Connector Name	REAR WINDOW DEFOGGER
Connector Type	PG1FE-A



Terminal No.	Color Of Wire	Signal Name [Specification]
1	Y	-

Connector No.	D185
Connector Name	REAR WINDOW DEFOGGER
Connector Type	PG1FE-A



Terminal No.	Color Of Wire	Signal Name [Specification]
2	B	-

Connector No.	E11
Connector Name	POWER (MULTI-COLOR POWER SYSTEM) (MULTI-COLOR ENGINE ROOM)
Connector Type	TH08FW-WH



Terminal No.	Color Of Wire	Signal Name [Specification]
39	L	-
40	B	-
41	B	-
42	SB	-
43	LG	-
44	W	-
45	Y	-
46	O	-

Connector No.	E105
Connector Name	WIRE TO WIRE
Connector Type	TH08FW-CS10-M3



Terminal No.	Color Of Wire	Signal Name [Specification]
1	SHIELD	-
2	W	-
3	B	-
4	R	-
6	LG	-
7	R	-
8	GR	-
9	V	-
10	BR	-
11	Y	-
12	O	-
13	W	-
14	L	-
15	P	-
31	GR	-
32	O	-
33	BR	-
34	Y	-
35	P	-
36	W	-
37	V	-
40	P	-
41	L	-
42	LG	-
43	O	-
45	P	-
46	SB	-
47	V	-
49	L	-
51	BR	-
52	G	-
53	B	-
54	O	-
55	Y	-
56	SHIELD	-
61	P	-
62	G	-
63	W/L	-

A
B
C
D
E
F
G
H
I
J
K
DEF
M
N
O
P

REAR WINDOW DEFOGGER SYSTEM

< WIRING DIAGRAM >

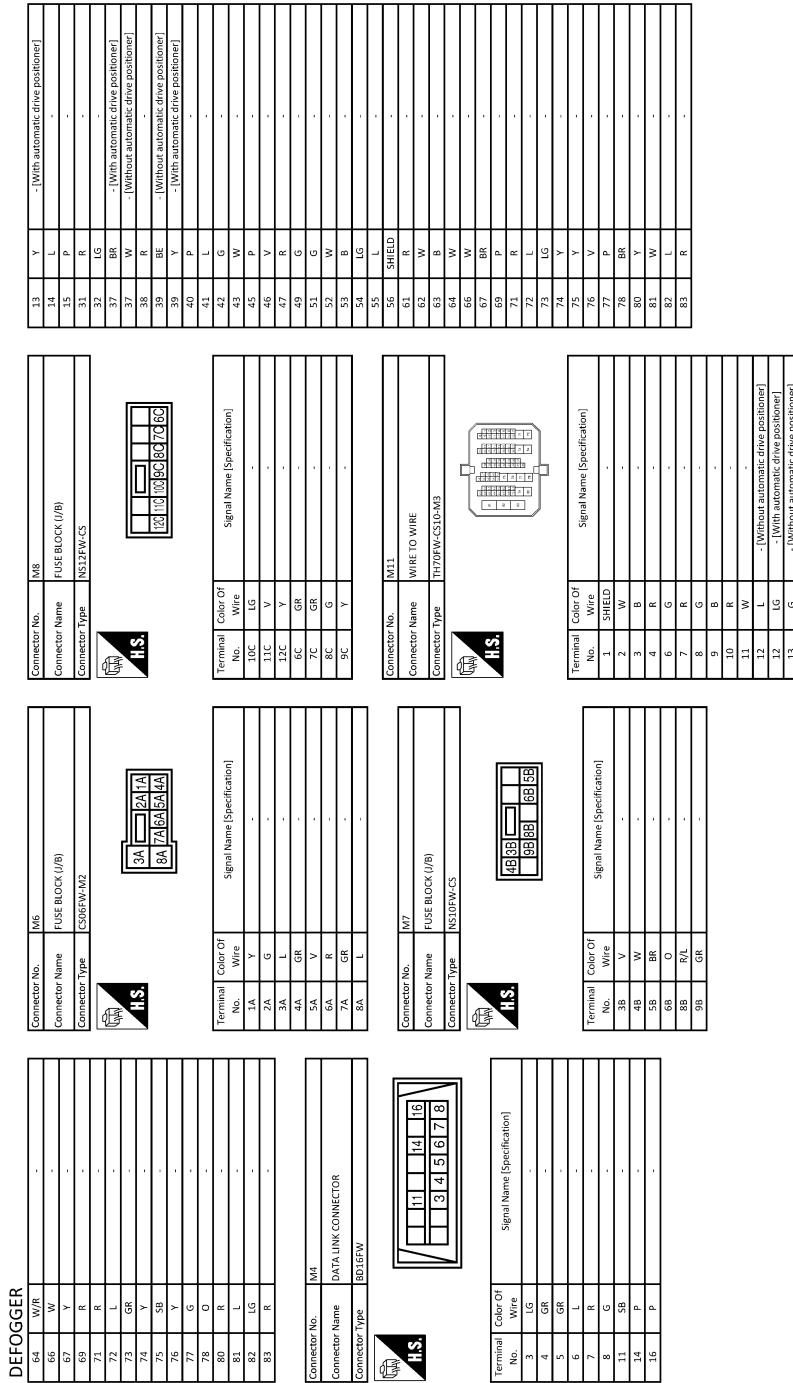

JRLWF6645GB

REAR WINDOW DEFOGGER SYSTEM

< WIRING DIAGRAM >

DEFOGGER

Connector No.	M18
Connector Name	WIRE TO WIRE
Connector Type	TH403WV-CS15



1	2	3	4	5	6	7	8	9	10	11	12	13	14	15
1	2	3	4	5	6	7	8	9	10	11	12	13	14	15

Terminal No.	Wire	Signal Name [Specification]
1	B	-
2	R	-
3	W	-
4	Y	-
5	SB	-
6	LG	-
7	V	-
8	L	-
9	GR	-
10	Y	-
11	V	-
12	G	-
13	G	-
14	B	-
14	R	- [Without BOSE system]
15	W	- [Without BOSE system]
15	W	- [Without BOSE system]
16	BE	-
18	P	-
19	W	-
20	LG	-
21	P	-
22	G	-
23	R	-
24	B	-
25	W	-
26	SHIELD	-
27	Y	-
28	G	-
29	W	-
30	R	-
31	W	-
32	G	-
33	BE	-
34	P	-

DEFOGGER

Connector No.	M18
Connector Name	WIRE TO WIRE
Connector Type	TH403WV-CS15



1	2	3	4	5	6	7	8	9	10	11	12	13	14	15
1	2	3	4	5	6	7	8	9	10	11	12	13	14	15

Terminal No.	Wire	Signal Name [Specification]
35	W	-
36	LG	-
37	W	-
38	Y	-
39	V	-
40	R	-
41	B	-
42	W	-
43	G	-
44	B	-
44	B	- [With around view monitor]
45	GR	- [Without around view monitor]
46	R	- [Without around view monitor]
46	W	- [With BOSE system]
47	GR	- [With around view monitor]
48	GR	-
49	P	- [Without automatic drive positioner]
49	R	- [With automatic drive positioner]
50	GR	- [With automatic drive positioner]
50	W	- [Without automatic drive positioner]
51	B	-
51	G	- [With automatic drive positioner]
52	GR	- [Without automatic drive positioner]
52	P	- [With automatic drive positioner]
53	SHIELD	-
54	W	-
55	B	-

Connector No.	M20
Connector Name	WIRE TO WIRE
Connector Type	TH403WV-CS15



1	2	3	4	5	6	7	8	9	10	11	12	13	14	15
1	2	3	4	5	6	7	8	9	10	11	12	13	14	15

Terminal No.	Wire	Signal Name [Specification]
7	B	-
8	L	- [With manual A/C]
8	Y	- [With auto A/C]
9	GR	- [With manual A/C]
9	LG	- [With auto A/C]
10	V	-
11	SB	-

DEFOGGER

Connector No.	M19
Connector Name	A/C AMP.
Connector Type	TH403WV-NH



1	2	3	4	5	6	7	8	9	10	11	12	13	14	15
1	2	3	4	5	6	7	8	9	10	11	12	13	14	15

Terminal No.	Wire	Signal Name [Specification]
12	V	-
14	L	- [Without BOSE system]
14	G	- [With BOSE system]
15	G	-
16	Y	-
17	P	-
18	R	-
19	LG	-
21	R	-
22	B	-
23	W	-
24	SHIELD	-
25	B	-
26	W	-
36	LG	-
37	W	-
38	P	-
39	Y	-
41	GR	-
42	BE	-
43	R	-
46	GR	-
50	W	-
51	B	-
52	GR	-
53	SHIELD	-
54	W	-
55	B	-

Connector No.	M19
Connector Name	A/C AMP.
Connector Type	TH403WV-NH



1	2	3	4	5	6	7	8	9	10	11	12	13	14	15
1	2	3	4	5	6	7	8	9	10	11	12	13	14	15

Terminal No.	Wire	Signal Name [Specification]
1	P	BATTERY POWER SUPPLY
2	G	IGNITION POWER SUPPLY
4	SB	DOOR MOTOR POWER SUPPLY
5	BR	LAN SIGNAL
7	R	REAR WINDOW DEFOGGER F/BS SIGNAL
8	P	ILLUMINATION POWER SUPPLY
9	GR	A/C POWER SUPPLY
10	W	FRONT BLOWER MOTOR CONTROL SIGNAL
12	BE	BLOWER FAN ON SIGNAL
13	G	A/C ON SIGNAL
15	GR	IONIZER ON/OFF CONTROL SIGNAL
17	G	ENGINE COOLANT TEMPERATURE SIGNAL
18	W	SUNLOAD SENSOR SIGNAL
19	P	FRONT IN-VEHICLE SENSOR SIGNAL
20	R	A/C AUTO AMP. CONNECTION RECOGNITION SIGNAL
21	B	GROUND
23	B	GROUND
24	BE	VEHICLE SPEED SIGNAL

DEFOGGER

Connector No.	M50
Connector Name	A/C AUTO AMP.
Connector Type	TH403WV-NH



1	2	3	4	5	6	7	8	9	10	11	12	13	14	15
1	2	3	4	5	6	7	8	9	10	11	12	13	14	15

Terminal No.	Wire	Signal Name [Specification]
7	R	REAR WINDOW DEFOGGER F/BS SIGNAL
8	GR	ILLUMINATION POWER SUPPLY
9	GR	A/C POWER SUPPLY
10	G	FRONT BLOWER MOTOR CONTROL SIGNAL
12	BE	BLOWER FAN ON SIGNAL
13	G	A/C ON SIGNAL
17	G	ENGINE COOLANT TEMPERATURE SIGNAL
21	B	GROUND
23	B	GROUND
27	BE	REAR WINDOW DEFOGGER ON SIGNAL
28	GR	ILLUMINATION GROUND
30	R	REAR BLOWER MOTOR CONTROL SIGNAL
32	G	COMM (A/C AUTO AMP.-RR A/C CONT)
33	W	COMM (RR A/C CONT.-A/C AUTO AMP.)
37	BE	INTAKE SENSOR SIGNAL
40	G	SENSOR GROUND

Connector No.	M50
Connector Name	A/C AUTO AMP.
Connector Type	TH403WV-NH



1	2	3	4	5	6	7	8	9	10	11	12	13	14	15
1	2	3	4	5	6	7	8	9	10	11	12	13	14	15

Terminal No.	Wire	Signal Name [Specification]
7	R	REAR WINDOW DEFOGGER F/BS SIGNAL
8	P	ILLUMINATION POWER SUPPLY
9	GR	A/C POWER SUPPLY
10	W	FRONT BLOWER MOTOR CONTROL SIGNAL
12	BE	BLOWER FAN ON SIGNAL
13	G	A/C ON SIGNAL
15	GR	IONIZER ON/OFF CONTROL SIGNAL
17	G	ENGINE COOLANT TEMPERATURE SIGNAL
18	W	SUNLOAD SENSOR SIGNAL
19	P	FRONT IN-VEHICLE SENSOR SIGNAL
20	R	A/C AUTO AMP. CONNECTION RECOGNITION SIGNAL
21	B	GROUND
23	B	GROUND
24	BE	VEHICLE SPEED SIGNAL

A
B
C
D
E
F
G
H
I
J
K
DEF
M
N
O
P

REAR WINDOW DEFOGGER SYSTEM

< WIRING DIAGRAM >

DEFOGGER

27	BE	REAR WINDOW DEFOGGER ON SIGNAL
28	GR	LUMINA MOTOR CONTROL SIGNAL
29	GR	REAR BLINDERS MOTOR CONTROL SIGNAL
30	G	COMM (A/C AUTO AMP - SR (A/C CONT))
31	W	COMM (FR A/C CONT - SW (A/C AUTO AMP))
32	W	COMM (FR A/C CONT - SW (A/C AUTO AMP))
33	W	COMM (FR A/C CONT - SW (A/C AUTO AMP))
34	R	EPH GAS TON INSECTOR DETECTING SENSOR SIGNAL
35	R	INTAKE SENSOR SIGNAL
36	GR	REAR IN VEHICLE SENSOR SIGNAL
37	GR	REAR IN VEHICLE SENSOR SIGNAL
38	GR	REAR IN VEHICLE SENSOR SIGNAL
39	L	AMBIENT SENSOR SIGNAL
40	G	SENSOR GROUND

Connector No.	M106
Connector Name	JOINT CONNECTOR M15
Connector Type	B130FW

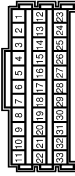

Terminal No.	Color Of Wire	Signal Name (Specification)
1	B	-
2	B	-
3	B	-
4	B	-
5	L	-
6	L	-
7	L	-
8	GR	-
9	Y	-
10	Y	-
11	Y	-
12	R	-
13	R	-
14	R	-
15	R	-
16	R	-
17	Y	-
18	Y	-
19	Y	-
20	Y	-
21	G	- [Without automatic drive positioner]
22	G	- [With automatic drive positioner]
23	GR	- [Without automatic drive positioner]
24	GR	- [With automatic drive positioner]
25	GR	-
26	V	-

27	V	-
28	V	-
29	SB	-
30	BE	-
31	SE	-
32	SE	-
33	BE	-

Connector No.	M121
Connector Name	BCM (BODY CONTROL MODULE)
Connector Type	TH407B-NH



Terminal No.	Color Of Wire	Signal Name (Specification)
1	W	REAR WINDOW DEF RELAY CONT
2	R	COMBI SW INPUT 5
3	G	COMBI SW INPUT 4
4	BE	COMBI SW INPUT 3
5	G	COMBI SW INPUT 2
6	W	COMBI SW INPUT 1
7	W	KEY SW INPUT
8	GR	PW SW COMBI (With automatic drive positioner)
9	Y	KEY LOCK SW (With automatic drive positioner)
10	GR	STOP LAMP SW 1
11	GR	DOOR LK & UNLK SW LOCK
12	GR	DOOR LK & UNLK SW UNLOCK
13	L	OPTICAL SENS
14	L	REAR WINDOW DEF SW
15	W	DIMMER
16	Y	DIMMER
17	O	SENS PWRSPLY
18	R	RECEIV/SENS GND
19	W	MATS ANT AMP
20	W	SECURITY IND CONT
21	P	MATS ANT AMP
22	P	MATS ANT AMP
23	O	A/C ON
24	BR	BLOWER FAN ON
25	P	HAZARD SW
26	L	BK DOOR OPMR SW
27	L	DR DOOR UNLK SENS
28	R	COMBI SW OUTPUT 5
29	W	COMBI SW OUTPUT 4

34	P	COMBI SW OUTPUT 3
35	GR	COMBI SW OUTPUT 2
36	GR	COMBI SW OUTPUT 1
37	C	DEFIN SW
38	BE	RECEIVER COMM
39	L	CAN-H
40	P	CAN-L

Connector No.	M123
Connector Name	BCM (BODY CONTROL MODULE)
Connector Type	FEA09FW-FHA6-SA

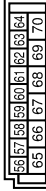

Terminal No.	Color Of Wire	Signal Name (Specification)
56	P	INT ROOM LAMP PWRSPLY
57	Y	BAT
58	O	AIRBAG
59	SB	PASS DOOR UNLK OUTPUT
60	V	TURNSIGLH OUTPUT
61	V	TURNSIGLH OUTPUT
62	W	EXT LAMP
63	R	INT ROOM LAMP CONT
64	W	CRANK REA
65	V	ALL DOOR LOCK OUTPUT
66	G	DR DOOR UNLK OUTPUT
67	B	GROUND
68	L	PW PWRSPLY (IGN)
69	P	PW PWRSPLY (BAT)
70	L	BAT

DIAGNOSIS AND REPAIR WORK FLOW

< BASIC INSPECTION >

BASIC INSPECTION

DIAGNOSIS AND REPAIR WORK FLOW

Work Flow

INFOID:0000000012409532

DETAILED FLOW

1.OBTAIN INFORMATION ABOUT SYMPTOM

Interview the customer to obtain the malfunction information (conditions and environment when the malfunction occurred) as much as possible when the customer brings the vehicle in.

>> GO TO 2.

2.CHECK FOR DTC

Perform self diagnosis with CONSULT

Is any DTC detected?

YES >> BCM: Refer to [BCS-64, "DTC Index"](#).

NO >> GO TO 3.

3.REPRODUCE THE MALFUNCTION INFORMATION

Check the malfunction on the vehicle that the customer describes.
Inspect the relation of the symptoms and the condition when the symptoms occur.

>> GO TO 4.

4.IDENTIFY THE MALFUNCTIONING SYSTEM WITH "SYMPTOM DIAGNOSIS"

Use "Symptom diagnosis" from the symptom inspection result in step 3. Then identify where to start performing the diagnosis based on possible causes and symptoms.

>> GO TO 5.

5.IDENTIFY MALFUNCTIONING PARTS WITH "COMPONENT DIAGNOSIS"

Perform the diagnosis with "Component diagnosis" of the applicable system.

>> GO TO 6.

6.REPAIR OR REPLACE THE MALFUNCTIONING PARTS

Repair or replace the specified malfunctioning parts.

>> GO TO 7.

7.FINAL CHECK

Check that malfunctions are not reproduced when obtaining the malfunction information from the customer, referring to the symptom inspection result in step 3.

Are all malfunctions corrected?

YES >> INSPECTION END

NO >> GO TO 4.

A
B
C
D
E
F
G
H
I
J
K
DEF
M
N
O
P

REAR WINDOW DEFOGGER SWITCH

< DTC/CIRCUIT DIAGNOSIS >

DTC/CIRCUIT DIAGNOSIS

REAR WINDOW DEFOGGER SWITCH WITH AUTO A/C

WITH AUTO A/C : Component Function Check

INFOID:000000012409533

1. CHECK REAR WINDOW DEFOGGER SWITCH FUNCTION

1. Perform ("REAR DEF SW") in BCM - REAR DEFOGGER "DATA MONITOR" mode by using CONSULT.
2. Operate rear window defogger switch and check Monitor Status on CONSULT screen.

Monitor Item	Condition		Monitor Status
REAR DEF SW	Rear window defogger switch	Pressed	On
		Released	Off

Is the inspection result normal?

- YES >> Rear window defogger switch function is OK.
 NO >> Refer to [DEF-22, "WITH AUTO A/C : Diagnosis Procedure"](#).

WITH AUTO A/C : Diagnosis Procedure

INFOID:000000012409534

1. CHECK AUTO A/C

Check the operating condition of auto A/C

Does auto A/C operate normally?

- YES >> GO TO 2.
 NO >> Perform auto A/C diagnosis. Refer to [HAC-76, "Work Flow"](#).

2. CHECK BCM OUTPUT SIGNAL

1. Turn ignition switch OFF.
2. Disconnect A/C auto amp. connector.
3. Check voltage between A/C auto amp. harness connector and ground by oscilloscope.

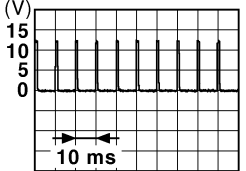
(+)		(-)	Voltage (Approx.)
A/C auto amp.			
Connector	Terminal		
M50	27	Ground	 <p style="text-align: right; font-size: small;">JPMIA0012GB</p>

Is the inspection result normal?

- YES >> GO TO 4.
 NO >> GO TO 3.

3. CHECK REAR WINDOW DEFOGGER SWITCH CIRCUIT

1. Disconnect BCM connector.
2. Check continuity between BCM harness connector and A/C auto amp. harness connector.

BCM		A/C auto amp.		Continuity
Connector	Terminal	Connector	Terminal	
M121	15	M50	27	Existed

3. Check continuity between BCM harness connector and ground.

REAR WINDOW DEFOGGER SWITCH

< DTC/CIRCUIT DIAGNOSIS >

BCM		Ground	Continuity
Connector	Terminal		
M121	15		Not existed

Is the inspection result normal?

- YES >> Replace BCM. Refer to [BCS-99, "Removal and Installation"](#).
NO >> Repair or replace harness.

4. REPLACE A/C AUTO AMP.

1. Turn ignition switch OFF.
2. Replace A/C auto amp.
3. Turn ignition switch ON.
4. Operate rear window defogger switch and check the operating condition.

Is the inspection result normal?

- YES >> INSPECTION END.
NO >> GO TO 5.

5. CHECK INTERMITTENT INCIDENT

Refer to [GI-41, "Intermittent Incident"](#).

Is the inspection result normal?

>> INSPECTION END

WITH MANUAL A/C

WITH MANUAL A/C : Component Function Check

INFOID:000000012409535

1. CHECK REAR WINDOW DEFOGGER SWITCH FUNCTION

1. Perform ("REAR DEF SW") in BCM - REAR DEFOGGER "DATA MONITOR" mode by using CONSULT.
2. Operate rear window defogger switch and check Monitor Status on CONSULT screen.

Monitor Item	Condition	Monitor Status
REAR DEF SW	Rear window defogger switch Pressed	On
	Released	Off

Is the inspection result normal?

- YES >> Rear window defogger switch function is OK.
NO >> Refer to [DEF-23, "WITH MANUAL A/C : Diagnosis Procedure"](#).

WITH MANUAL A/C : Diagnosis Procedure

INFOID:000000012409536

1. CHECK MANUAL A/C

Check the operating condition of manual A/C

Does manual A/C operate normally?

- YES >> GO TO 2.
NO >> Perform manual A/C diagnosis. Refer to [HAC-196, "Work Flow"](#).

2. CHECK BCM OUTPUT SIGNAL

1. Turn ignition switch OFF.
2. Disconnect A/C amp. connector.
3. Check voltage between A/C amp. harness connector and ground by oscilloscope.

A
B
C
D
E
F
G
H
I
J
K
M
N
O
P

DEF

REAR WINDOW DEFOGGER SWITCH

< DTC/CIRCUIT DIAGNOSIS >

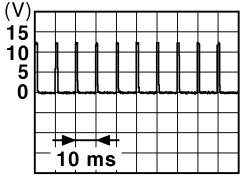
(+)		(-)	Voltage (Approx.)
A/C amp.			
Connector	Terminal		
M49	27	Ground	 <small>JPMIA0012GB</small>

Is the inspection result normal?

- YES >> GO TO 4.
 NO >> GO TO 3.

3. CHECK REAR WINDOW DEFOGGER SWITCH CIRCUIT

1. Disconnect BCM connector.
2. Check continuity between BCM harness connector and A/C amp. harness connector.

BCM		A/C amp.		Continuity
Connector	Terminal	Connector	Terminal	
M121	15	M49	27	Existed

3. Check continuity between BCM harness connector and ground.

BCM		Ground	Continuity
Connector	Terminal		
M121	15		Not existed

Is the inspection result normal?

- YES >> Replace BCM. Refer to [BCS-99, "Removal and Installation"](#).
 NO >> Repair or replace harness.

4. REPLACE A/C AMP.

1. Turn ignition switch OFF.
2. Replace A/C amp.
3. Turn ignition switch ON.
4. Operate rear window defogger switch and check the operating condition.

Is the inspection result normal?

- YES >> INSPECTION END.
 NO >> GO TO 5.

5. CHECK INTERMITTENT INCIDENT

Refer to [GI-41, "Intermittent Incident"](#).

Is the inspection result normal?

>> INSPECTION END

REAR WINDOW DEFOGGER RELAY

< DTC/CIRCUIT DIAGNOSIS >

REAR WINDOW DEFOGGER RELAY

Component Function Check

INFOID:000000012409537

1.CHECK REAR WINDOW DEFOGGER RELAY POWER SUPPLY CIRCUIT

1. Perform BCM Active Test ("REAR DEFOGGER") with CONSULT.
2. Touch "ON".
3. Check that the rear window heating wire is getting warmer.

Is the inspection result normal?

- YES >> Rear window defogger relay power supply circuit function is OK.
NO >> Refer to [DEF-25. "Diagnosis Procedure"](#).

Diagnosis Procedure

INFOID:000000012409538

1.CHECK FUSE

1. Turn ignition switch OFF.
2. Check 10A fuse [No.3, located in fuse block (J/B)].

Is the inspection result normal?

- YES >> GO TO 2.
NO >> Replace the blown fuse after repairing the affected circuit if a fuse is blown.

2.CHECK REAR WINDOW DEFOGGER CIRCUIT 1

1. Turn ignition switch ON.
2. Check voltage between BCM harness connector and ground.

(+)		(-)	Condition	Voltage (V) (Approx.)	
BCM					
Connector	Terminal				
M121	1	Ground	Rear window de-fogger switch	ON	0
				OFF	Battery voltage

Is the inspection result normal?

- YES >> GO TO 6.
Fixed at 0 V>>GO TO 3.
Fixed at 9 – 16 V >>Replace BCM. Refer to [BCS-99. "Removal and Installation"](#).

3.CHECK REAR WINDOW DEFOGGER CIRCUIT 2

1. Turn ignition switch OFF.
2. Disconnect BCM connector and fuse block (J/B).
3. Check continuity between BCM harness connector and fuse block (J/B) harness connector.

BCM		Fuse block (J/B)		Continuity
Connector	Terminal	Connector	Terminal	
M121	1	M7	4B	Existed

Is the inspection result normal?

- YES >> GO TO 4.
NO >> Repair or replace harness.

4.CHECK REAR WINDOW DEFOGGER RELAY 1

Check rear window defogger relay.
Refer to [DEF-26. "Component Inspection"](#).

Is the inspection result normal?

- YES >> GO TO 5.
NO >> Replace rear window defogger relay.

5.CHECK FUSE BLOCK (J/B)

A
B
C
D
E
F
G
H
I
J
K
M
N
O
P

DEF

REAR WINDOW DEFOGGER RELAY

< DTC/CIRCUIT DIAGNOSIS >

1. Install the rear window defogger relay.
2. Turn ignition switch ON.
3. Check voltage between fuse block (J/B) connector (fuse block side) and ground.

(+)		(-)	Voltage (V) (Approx.)
Fuse block (J/B)			
Connector	Terminal		
M7	4B	Ground	Battery voltage

Is the inspection result normal?

- YES >> GO TO 7.
 NO >> Replace fuse block (J/B).

6. CHECK REAR WINDOW DEFOGGER RELAY 2

Check rear window defogger relay.
 Refer to [DEF-26, "Component Inspection"](#).

Is the inspection result normal?

- YES >> GO TO 7.
 NO >> Replace rear window defogger relay.

7. CHECK INTERMITTENT INCIDENT

Check intermittent incident.
 Refer to [GI-41, "Intermittent Incident"](#).

>> INSPECTION END

Component Inspection

INFOID:000000012409539

1. CHECK REAR WINDOW DEFOGGER RELAY

1. Turn ignition switch OFF.
2. Disconnect rear window defogger relay.
3. Check rear window defogger relay.

Rear window defogger relay		Condition	Continuity
Terminal			
3	5	12 V direct current supply between terminals 1 and 2	Existed
		No current supply	Not existed

Is the inspection result normal?

- YES >> INSPECTION END
 NO >> Replace rear window defogger relay.

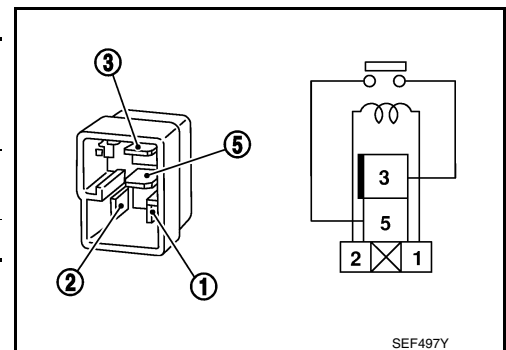

REAR WINDOW DEFOGGER

< DTC/CIRCUIT DIAGNOSIS >

REAR WINDOW DEFOGGER

Component Function Check

INFOID:000000012409540

1.CHECK REAR WINDOW DEFOGGER

1. Perform Active Test ("REAR DEFOGGER") with CONSULT.
2. Touch "ON".
3. Check that the rear window heating wire is getting warmer.

Is the inspection result normal?

- YES >> Rear window defogger is OK.
NO >> Refer to [DEF-27, "Diagnosis Procedure"](#).

Diagnosis Procedure

INFOID:000000012409541

1.CHECK FUSE

1. Turn ignition switch OFF.
2. Check 20A fuse [No.15, located in fuse block (J/B)].

Is the inspection result normal?

- YES >> GO TO 2.
NO >> Replace the blown fuse after repairing the affected circuit if a fuse is blown.

2.CHECK POWER SUPPLY CIRCUIT

1. Disconnect rear window defogger harness connector.
2. Turn ignition switch ON.
3. Check voltage between rear window defogger connector and ground.

(+)		(-)	Condition		Voltage (V) (Approx.)
Connector	Terminal				
D184	1	Ground	Rear window defogger switch	ON	Battery voltage
				OFF	0

Is the inspection result normal?

- YES >> GO TO 3.
NO >> GO TO 4.

3.CHECK GROUND CIRCUIT

1. Turn ignition switch OFF.
2. Check continuity between rear window defogger harness connector and ground.

Rear window defogger		Ground	Continuity
Connector	Terminal		
D185	2		Existed

Is the inspection result normal?

- YES >> GO TO 6.
NO >> Repair or replace harness or connector between rear window defogger and ground.

4.CHECK REAR WINDOW DEFOGGER CIRCUIT

1. Turn ignition switch OFF.
2. Disconnect fuse block (J/B) harness connector.
3. Check continuity between fuse block (J/B) harness connector and rear window defogger harness connector.

REAR WINDOW DEFOGGER

< DTC/CIRCUIT DIAGNOSIS >

Fuse block (J/B)		Rear window defogger		Continuity
Connector	Terminal	Connector	Terminal	
B12	10G	D184	1	Existed

Is the inspection result normal?

YES >> GO TO 5.

NO >> Repair or replace harness or connector between fuse block (J/B) and rear window defogger.

5.CHECK FUSE BLOCK (J/B)

1. Turn ignition switch ON.
2. Check voltage between fuse block (J/B) connector (fuse block side) and ground.

(+) Fuse block (J/B)		(-)	Condition	Voltage (V) (Approx.)
Connector	Terminal			
B12	10G	Ground	Rear window defogger switch	ON Battery voltage
				OFF 0

Is the inspection result normal?

YES >> GO TO 7.

NO >> Replace fuse block (J/B).

6.CHECK FILAMENT

Check the filament for damage or blown.
Refer to [DEF-41, "Inspection and Repair"](#).

Is the inspection result normal?

YES >> GO TO 7.

NO >> Repair filament.

7.CHECK INTERMITTENT INCIDENT

Check intermittent incident.
Refer to [GI-41, "Intermittent Incident"](#).

>> INSPECTION END

DOOR MIRROR DEFOGGER

< DTC/CIRCUIT DIAGNOSIS >

DOOR MIRROR DEFOGGER

Component Function Check

INFOID:000000012409542

1.CHECK DOOR MIRROR DEFOGGER

1. Perform Active Test ("REAR DEFOGGER") with CONSULT.
2. Touch "ON".
3. Check that both side door mirror glasses are getting warmer.

Is the inspection result normal?

- YES >> Door mirror defoggers are OK.
NO >> Refer to [DEF-29, "Diagnosis Procedure"](#).

Diagnosis Procedure

INFOID:000000012409543

1.CHECK DOOR MIRROR DEFOGGER CIRCUIT

1. Turn ignition switch OFF.
2. Disconnect door mirror (both sides) connectors.
3. Turn ignition switch ON.
4. Check voltage between door mirror (driver side) connector and ground.

(+)		(-)	Condition		Voltage (V) (Approx.)
Door mirror (driver side)					
Connector	Terminal	Ground	Rear window defogger switch	ON	Battery voltage
D43	7				OFF

Is the inspection result normal?

- YES >> GO TO 3.
NO >> GO TO 2.

2.CHECK FUSE BLOCK (J/B)

1. Turn ignition switch OFF.
2. Disconnect fuse block (J/B) harness connector.
3. Turn ignition switch ON.
4. Check voltage between fuse block (J/B) connector (fuse block side) and ground.

(+)		(-)	Condition		Voltage (V) (Approx.)
Fuse block (J/B)					
Connector	Terminal	Ground	Rear window defogger switch	ON	Battery voltage
M8	10C				OFF

Is the inspection result normal?

- YES >> Repair or replace harness or connector between fuse block (J/B) and door mirror (driver side).
NO >> Replace fuse block (J/B).

3.CHECK INTERMITTENT INCIDENT

Check intermittent incident.
Refer to [GI-41, "Intermittent Incident"](#).

Is the inspection result normal?

>> INSPECTION END

A
B
C
D
E
F
G
H
I
J
K
DEF
M
N
O
P

DRIVER SIDE DOOR MIRROR DEFOGGER

< DTC/CIRCUIT DIAGNOSIS >

DRIVER SIDE DOOR MIRROR DEFOGGER

Component Function Check

INFOID:000000012409544

1.CHECK DRIVER SIDE DOOR MIRROR DEFOGGER

1. Perform Active Test ("REAR DEFOGGER") with CONSULT.
2. Touch "ON".
3. Check that the driver side door mirror glass is getting warmer.

Is the inspection result normal?

- YES >> Driver side door mirror defogger is OK.
NO >> Refer to [DEF-30, "Diagnosis Procedure"](#).

Diagnosis Procedure

INFOID:000000012409545

1.CHECK POWER SUPPLY CIRCUIT

1. Turn ignition switch OFF.
2. Disconnect door mirror (driver side) connector.
3. Turn ignition switch ON.
4. Check voltage between door mirror (driver side) harness connector and ground.

(+)		(-)	Condition		Voltage (V) (Approx.)
Door mirror (driver side) Connector	Terminal				
D43	7	Ground	Rear window defogger switch	ON	Battery voltage
				OFF	0

Is the inspection result normal?

- YES >> GO TO 2.
NO >> Repair or replace harness or connector between fuse block (J/B) and door mirror (driver side).

2.CHECK GROUND CIRCUIT

1. Turn ignition switch OFF.
2. Check continuity between door mirror (driver side) harness connector and ground.

Door mirror (driver side)		Ground	Continuity
Connector	Terminal		
D43	19		Existed

Is the inspection result normal?

- YES >> Replace glass mirror (driver side).
NO >> Repair or replace harness or connector between door mirror (driver side) and ground.

PASSENGER SIDE DOOR MIRROR DEFOGGER

< DTC/CIRCUIT DIAGNOSIS >

PASSENGER SIDE DOOR MIRROR DEFOGGER

Component Function Check

INFOID:000000012409546

1.CHECK PASSENGER SIDE DOOR MIRROR DEFOGGER

1. Perform Active Test ("REAR DEFOGGER") with CONSULT.
2. Touch "ON".
3. Check that the passenger side door mirror glass is getting warmer.

Is the inspection result normal?

- YES >> Passenger side door mirror defogger is OK.
NO >> Refer to [DEF-31. "Diagnosis Procedure"](#).

Diagnosis Procedure

INFOID:000000012409547

1.CHECK POWER SUPPLY CIRCUIT

1. Turn ignition switch OFF.
2. Disconnect door mirror (passenger side) connector.
3. Turn ignition switch ON.
4. Check voltage between door mirror (passenger side) harness connector and ground.

(+)		(-)	Condition		Voltage (V) (Approx.)
Door mirror (Passenger side) Connector	Terminal				
D3	7	Ground	Rear window defogger switch	ON	Battery voltage
				OFF	0

Is the inspection result normal?

- YES >> GO TO 2.
NO >> Repair or replace harness or connector between fuse block (J/B) and door mirror (passenger side).

2.CHECK GROUND CIRCUIT

1. Turn ignition switch OFF.
2. Check continuity between door mirror (passenger side) harness connector and ground.

Door mirror (passenger side)		Ground	Continuity
Connector	Terminal		
D3	19		Existed

Is the inspection result normal?

- YES >> Replace glass mirror (passenger side).
NO >> Repair or replace harness or connector between door mirror (passenger side) and ground.

A
B
C
D
E
F
G
H
I
J
K
DEF
M
N
O
P

REAR WINDOW DEFOGGER FEEDBACK SIGNAL

< DTC/CIRCUIT DIAGNOSIS >

REAR WINDOW DEFOGGER FEEDBACK SIGNAL WITH AUTO A/C

WITH AUTO A/C : Component Function Check

INFOID:000000012409548

1. CHECK REAR WINDOW DEFOGGER FEEDBACK SIGNAL

Check that the indicator lamp of rear window defogger switch is illuminated when turning the rear window defogger switch ON.

Is the inspection result normal?

YES >> Rear window defogger feedback signal is OK.

NO >> Refer to [DEF-32, "WITH AUTO A/C : Diagnosis Procedure"](#).

WITH AUTO A/C : Diagnosis Procedure

INFOID:000000012409549

1. CHECK FUSE

1. Turn ignition switch OFF.
2. Check 10A fuse [No.13, located in fuse block (J/B)]

Is the inspection result normal?

YES >> GO TO 2.

NO >> Replace the blown fuse after repairing the affected circuit if a fuse is blown.

2. CHECK REAR WINDOW DEFOGGER FEEDBACK SIGNAL

1. Disconnect A/C auto amp. connector.
2. Turn ignition switch ON.
3. Check voltage between A/C auto amp. harness connector and ground.

(+)		(-)	Condition		Voltage (V) (Approx.)
A/C auto amp.					
Connector	Terminal				
M50	7	Ground	Rear window defogger switch	ON	Battery voltage
				OFF	0

Is the inspection result normal?

YES >> Replace A/C auto amp.

NO >> GO TO 3.

3. CHECK REAR WINDOW DEFOGGER CIRCUIT

1. Turn ignition switch OFF.
2. Disconnect fuse block (J/B) connector.
3. Check continuity between fuse block (J/B) harness connector and A/C auto amp. harness connector.

Fuse block (J/B)		A/C auto amp.		Continuity
Connector	Terminal	Connector	Terminal	
M8	9C	M50	7	Existed

4. Check continuity between fuse block (J/B) and ground.

Fuse block (J/B)		Ground	Continuity
Connector	Terminal		
M8	9C		Not existed

Is the inspection result normal?

YES >> GO TO 4.

NO >> Repair or replace harness.

4. CHECK FUSE BLOCK (J/B)

REAR WINDOW DEFOGGER FEEDBACK SIGNAL

< DTC/CIRCUIT DIAGNOSIS >

1. Turn ignition switch ON.
2. Check voltage between fuse block (J/B) connector (fuse block side) and ground.

(+)		(-)	Condition	Voltage (V) (Approx.)	
Fuse block (J/B)					
Connector	Terminal				
M8	9C	Ground	Rear window defogger switch	ON	Battery voltage
			OFF	0	

Is the inspection result normal?

- YES >> GO TO 5.
 NO >> Replace fuse block (J/B).

5.CHECK INTERMITTENT INCIDENT

Check intermittent incident.
 Refer to [GI-41, "Intermittent Incident"](#).

>> INSPECTION END

WITH MANUAL A/C

WITH MANUAL A/C : Component Function Check

INFOID:000000012409550

1.CHECK REAR WINDOW DEFOGGER FEEDBACK SIGNAL

Check that the indicator lamp of rear window defogger switch is illuminated when turning the rear window defogger switch ON.

Is the inspection result normal?

- YES >> Rear window defogger feedback signal is OK.
 NO >> Refer to [DEF-33, "WITH MANUAL A/C : Diagnosis Procedure"](#).

WITH MANUAL A/C : Diagnosis Procedure

INFOID:000000012409551

1.CHECK FUSE

1. Turn ignition switch OFF.
2. Check 10A fuse [No.13, located in fuse block (J/B)]

Is the inspection result normal?

- YES >> GO TO 2.
 NO >> Replace the blown fuse after repairing the affected circuit if a fuse is blown.

2.CHECK REAR WINDOW DEFOGGER FEEDBACK SIGNAL

1. Disconnect A/C amp. connector.
2. Turn ignition switch ON.
3. Check voltage between A/C amp. harness connector and ground.

(+)		(-)	Condition	Voltage (V) (Approx.)	
A/C amp.					
Connector	Terminal				
M49	7	Ground	Rear window defogger switch	ON	Battery voltage
			OFF	0	

Is the inspection result normal?

- YES >> Replace A/C amp.
 NO >> GO TO 3.

3.CHECK REAR WINDOW DEFOGGER CIRCUIT

1. Turn ignition switch OFF.
2. Disconnect fuse block (J/B) connector.

A
B
C
D
E
F
G
H
I
J
K
M
N
O
P

DEF

REAR WINDOW DEFOGGER FEEDBACK SIGNAL

< DTC/CIRCUIT DIAGNOSIS >

3. Check continuity between fuse block (J/B) harness connector and A/C amp. harness connector.

Fuse block (J/B)		A/C amp.		Continuity
Connector	Terminal	Connector	Terminal	
M8	9C	M49	7	Existed

4. Check continuity between fuse block (J/B) and ground.

Fuse block (J/B)		Ground	Continuity
Connector	Terminal		
M8	9C		Not existed

Is the inspection result normal?

- YES >> GO TO 4.
 NO >> Repair or replace harness.

4. CHECK FUSE BLOCK (J/B)

1. Turn ignition switch ON.
 2. Check voltage between fuse block (J/B) connector (fuse block side) and ground.

(+)		(-)	Condition	Voltage (V) (Approx.)	
Fuse block (J/B)					
Connector	Terminal				
M8	9C	Ground	Rear window defogger switch	ON	Battery voltage
			OFF	0	

Is the inspection result normal?

- YES >> GO TO 5.
 NO >> Replace fuse block (J/B).

5. CHECK INTERMITTENT INCIDENT

Check intermittent incident.
 Refer to [GI-41, "Intermittent Incident"](#).

>> INSPECTION END

REAR WINDOW DEFOGGER DOES NOT OPERATE

< SYMPTOM DIAGNOSIS >

SYMPTOM DIAGNOSIS

REAR WINDOW DEFOGGER DOES NOT OPERATE

Description

INFOID:0000000012409552

For models without door mirror defogger.

Diagnosis Procedure

INFOID:0000000012409553

1. CHECK REAR WINDOW DEFOGGER SWITCH

Check rear window defogger switch.

Refer to [DEF-22, "WITH AUTO A/C : Component Function Check"](#) (with auto A/C) or [DEF-23, "WITH MANUAL A/C : Component Function Check"](#) (with manual A/C).

Is the inspection result normal?

YES >> GO TO 2.

NO >> Repair or replace the malfunctioning parts.

2. CHECK REAR WINDOW DEFOGGER RELAY

Check rear window defogger relay.

Refer to [DEF-25, "Component Function Check"](#).

Is the inspection result normal?

YES >> GO TO 3.

NO >> Repair or replace the malfunctioning parts.

3. CHECK REAR WINDOW DEFOGGER

Check rear window defogger.

Refer to [DEF-27, "Component Function Check"](#).

Is the inspection result normal?

YES >> GO TO 4.

NO >> Repair or replace the malfunctioning parts.

4. CONFIRM THE OPERATION

Confirm the operation again.

Is the inspection result normal?

YES >> Check intermittent incident. Refer to [GI-41, "Intermittent Incident"](#).

NO >> GO TO 1.

A

B

C

D

E

F

G

H

I

J

K

DEF

M

N

O

P

REAR WINDOW DEFOGGER AND DOOR MIRROR DEFOGGER DO NOT OPERATE

< SYMPTOM DIAGNOSIS >

REAR WINDOW DEFOGGER AND DOOR MIRROR DEFOGGER DO NOT OPERATE

Description

INFOID:000000012409554

For models with door mirror defogger.

Diagnosis Procedure

INFOID:000000012409555

1. CHECK REAR WINDOW DEFOGGER SWITCH

Check rear window defogger switch.

Refer to [DEF-22. "WITH AUTO A/C : Component Function Check"](#) (with auto A/C) or [DEF-23. "WITH MANUAL A/C : Component Function Check"](#) (with manual A/C).

Is the inspection result normal?

YES >> GO TO 2.

NO >> Repair or replace the malfunctioning parts.

2. CHECK REAR WINDOW DEFOGGER RELAY

Check rear window defogger relay.

Refer to [DEF-25. "Component Function Check"](#).

Is the inspection result normal?

YES >> GO TO 3.

NO >> Repair or replace the malfunctioning parts.

3. CHECK REAR WINDOW DEFOGGER

Check rear window defogger.

Refer to [DEF-27. "Component Function Check"](#).

Is the inspection result normal?

YES >> GO TO 4.

NO >> Repair or replace the malfunctioning parts.

4. CONFIRM THE OPERATION

Confirm the operation again.

Is the inspection result normal?

YES >> Check intermittent incident. Refer to [GI-41. "Intermittent Incident"](#).

NO >> GO TO 1.

REAR WINDOW DEFOGGER DOES NOT OPERATE BUT BOTH DOOR MIRROR DEFOGGERS OPERATE

< SYMPTOM DIAGNOSIS >

REAR WINDOW DEFOGGER DOES NOT OPERATE BUT BOTH DOOR MIRROR DEFOGGERS OPERATE

Description

INFOID:000000012409556

For models with door mirror defogger.

Diagnosis Procedure

INFOID:000000012409557

1.CHECK REAR WINDOW DEFOGGER

Check rear window defogger.

Refer to [DEF-27. "Component Function Check"](#).

Is the inspection result normal?

YES >> GO TO 2.

NO >> Repair or replace the malfunctioning parts.

2.CONFIRM THE OPERATION

Confirm the operation again

Is the inspection result normal?

YES >> Check intermittent incident. Refer to [GI-41. "Intermittent Incident"](#).

NO >> GO TO 1.

A
B
C
D
E
F
G
H
I
J
K
DEF
M
N
O
P

DOOR MIRROR DEFOGGER DOES NOT OPERATE

< SYMPTOM DIAGNOSIS >

DOOR MIRROR DEFOGGER DOES NOT OPERATE BOTH SIDES

BOTH SIDES : Description

INFOID:000000012409558

Driver side and passenger side door mirror defoggers do not operate.

BOTH SIDES : Diagnosis Procedure

INFOID:000000012409559

1.CHECK DOOR MIRROR DEFOGGER

Check door mirror defogger.

Refer to [DEF-29, "Component Function Check"](#).

Is the inspection result normal?

YES >> GO TO 2.

NO >> Repair or replace the malfunctioning parts.

2.CONFIRM THE OPERATION

Confirm the operation again.

Is the inspection result normal?

YES >> Check intermittent incident. Refer to [GI-41, "Intermittent Incident"](#).

NO >> GO TO 1.

DRIVER SIDE

DRIVER SIDE : Description

INFOID:000000012409560

Driver side door mirror defogger does not operate.

DRIVER SIDE : Diagnosis Procedure

INFOID:000000012409561

1.CHECK DRIVER SIDE DOOR MIRROR DEFOGGER

Check driver side door mirror defogger.

Refer to [DEF-30, "Component Function Check"](#).

Is the inspection result normal?

YES >> GO TO 2.

NO >> Repair or replace the malfunctioning parts.

2.CONFIRM THE OPERATION

Confirm the operation again.

Is the inspection result normal?

YES >> Check intermittent incident. Refer to [GI-41, "Intermittent Incident"](#).

NO >> GO TO 1.

PASSENGER SIDE

PASSENGER SIDE : Description

INFOID:000000012409562

Passenger side door mirror defogger does not operate.

PASSENGER SIDE : Diagnosis Procedure

INFOID:000000012409563

1.CHECK PASSENGER SIDE DOOR MIRROR DEFOGGER.

Check passenger side door mirror defogger.

Refer to [DEF-31, "Component Function Check"](#).

Is the inspection result normal?

YES >> GO TO 2.

NO >> Repair or replace the malfunctioning parts.

2.CONFIRM THE OPERATION

DOOR MIRROR DEFOGGER DOES NOT OPERATE

< SYMPTOM DIAGNOSIS >

Confirm the operation again.

Is the inspection result normal?

- YES >> Check intermittent incident. Refer to [GI-41. "Intermittent Incident"](#).
NO >> GO TO 1.

A

B

C

D

E

F

G

H

I

J

K

DEF

M

N

O

P

REAR WINDOW DEFOGGER INDICATOR DOES NOT ILLUMINATE

< SYMPTOM DIAGNOSIS >

REAR WINDOW DEFOGGER INDICATOR DOES NOT ILLUMINATE

Diagnosis Procedure

INFOID:000000012409564

1. CHECK REAR WINDOW DEFOGGER FEEDBACK SIGNAL

Check rear window defogger feedback signal.

Refer to [DEF-32. "WITH AUTO A/C : Component Function Check"](#) (With auto A/C) or [DEF-33. "WITH MANUAL A/C : Component Function Check"](#) (With manual A/C).

Is the inspection result normal?

YES >> GO TO 2.

NO >> Repair or replace the malfunctioning parts.

2. CONFIRM THE OPERATION

Confirm the operation again.

Is the inspection result normal?

YES >> Check intermittent incident. Refer to [GI-41. "Intermittent Incident"](#).

NO >> GO TO 1.

FILAMENT

< REMOVAL AND INSTALLATION >

REMOVAL AND INSTALLATION

FILAMENT

Inspection and Repair

INFOID:000000012409565

INSPECTION

1. When measuring voltage, wrap tin foil around the top of the negative probe. Then press the foil against the wire with your finger.

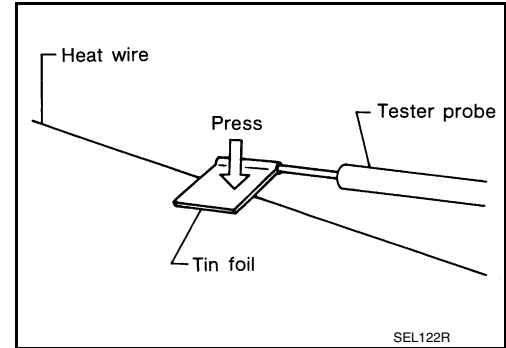

2. Attach probe circuit tester (in Volt range) to middle portion of each filament.

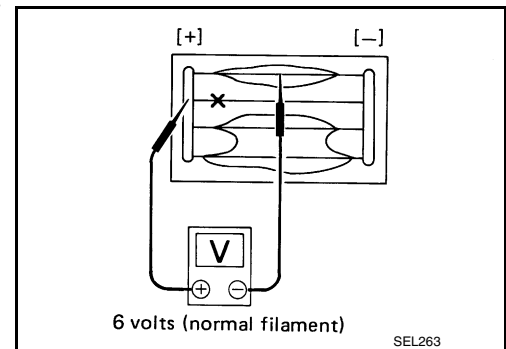

3. If a filament is burned out, circuit tester registers 0 or battery voltage.
4. To locate burned out point, move probe to left and right along filament. Test needle will swing abruptly when probe passes the point.

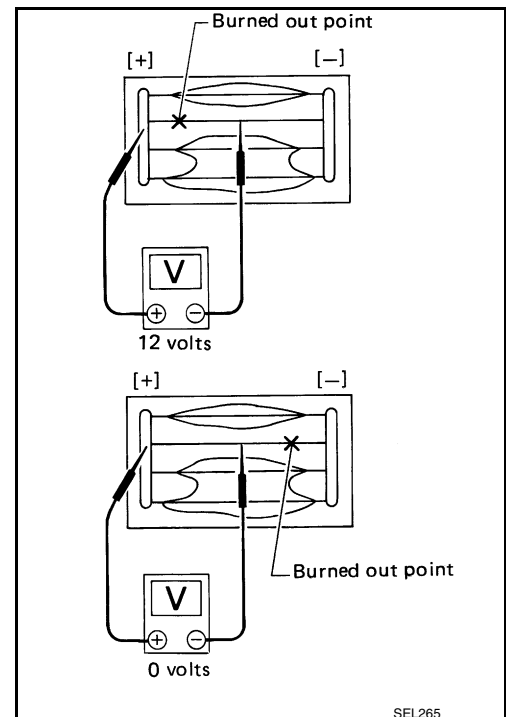

REPAIR

REPAIR EQUIPMENT

- Conductive silver composition (Dupont No. 4817 or equivalent)

A
B
C
D
E
F
G
H
I
J
K
DEF
M
N
O
P

FILAMENT

< REMOVAL AND INSTALLATION >

- Ruler 30 cm (11.8 in) long
- Drawing pen
- Heat gun
- Alcohol
- Cloth

REPAIRING PROCEDURE

1. Wipe broken heat wire and its surrounding area clean with a cloth dampened in alcohol.
2. Apply a small amount of conductive silver composition to tip of drawing pen. Shake silver composition container before use.
3. Place ruler on glass along broken line. Deposit conductive silver composition on break with drawing pen. Slightly overlap existing heat wire on both sides [preferably 5 mm (0.20 in)] of the break.

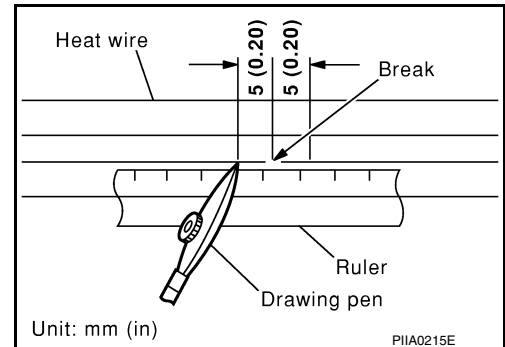

4. After repair has been completed, check repaired wire for continuity. This check should be conducted 10 minutes after silver composition is deposited. Do not touch repaired area while test is being conducted.

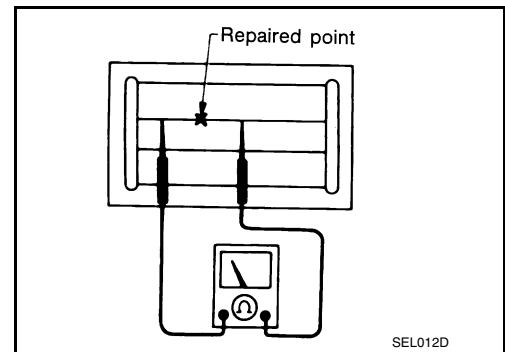

5. Apply a constant stream of hot air directly to the repaired area for approximately 20 minutes with a heat gun. A minimum distance of 3 cm (1.2 in) should be kept between repaired area and hot air outlet. If a heat gun is not available, let the repaired area dry for 24 hours.

