

A

# SECTION STR

STR

## STARTING SYSTEM

C

### CONTENTS

D

<b>PRECAUTION</b> .....	<b>DIAGNOSIS AND REPAIR WORK FLOW</b> .....	F
	Work Flow (With GR8-1200 NI) .....	
<b>PRECAUTIONS</b> .....	Work Flow (Without GR8-1200 NI) .....	
Precaution for Supplemental Restraint System (SRS) "AIR BAG" and "SEAT BELT PRE-TENSIONER" .....	<b>DTC/CIRCUIT DIAGNOSIS</b> .....	G
Precaution for Procedure without Cowl Top Cover.....	<b>B TERMINAL CIRCUIT</b> .....	H
Precautions for Removing Battery Terminal .....	Description .....	
Precautions For Xenon Headlamp Service .....	Diagnosis Procedure .....	
Precautions When Battery Is Discharged .....	<b>S CONNECTOR CIRCUIT</b> .....	I
<b>PREPARATION</b> .....	Description .....	
	Diagnosis Procedure .....	
<b>PREPARATION</b> .....	<b>SYMPTOM DIAGNOSIS</b> .....	J
Special Service Tools .....	<b>STARTING SYSTEM</b> .....	
Commercial Service Tools .....	Symptom Table .....	K
<b>SYSTEM DESCRIPTION</b> .....	<b>REMOVAL AND INSTALLATION</b> .....	L
<b>COMPONENT PARTS</b> .....	<b>STARTER MOTOR</b> .....	
Component Parts Location .....	Exploded View .....	
<b>SYSTEM</b> .....	Removal and Installation .....	M
System Description .....	<b>SERVICE DATA AND SPECIFICATIONS (SDS)</b> .....	N
<b>WIRING DIAGRAM</b> .....	<b>SERVICE DATA AND SPECIFICATIONS (SDS)</b> .....	O
<b>STARTING SYSTEM</b> .....	Starter Motor .....	P
Wiring Diagram .....		
<b>BASIC INSPECTION</b> .....		

# PRECAUTIONS

< PRECAUTION >

## PRECAUTION

### PRECAUTIONS

#### Precaution for Supplemental Restraint System (SRS) "AIR BAG" and "SEAT BELT PRE-TENSIONER"

INFOID:000000012408296

The Supplemental Restraint System such as "AIR BAG" and "SEAT BELT PRE-TENSIONER", used along with a front seat belt, helps to reduce the risk or severity of injury to the driver and front passenger for certain types of collision. This system includes seat belt switch inputs and dual stage front air bag modules. The SRS system uses the seat belt switches to determine the front air bag deployment, and may only deploy one front air bag, depending on the severity of a collision and whether the front occupants are belted or unbelted. Information necessary to service the system safely is included in the "SRS AIR BAG" and "SEAT BELT" of this Service Manual.

#### **WARNING:**

Always observe the following items for preventing accidental activation.

- To avoid rendering the SRS inoperative, which could increase the risk of personal injury or death in the event of a collision that would result in air bag inflation, all maintenance must be performed by an authorized NISSAN/INFINITI dealer.
- Improper maintenance, including incorrect removal and installation of the SRS, can lead to personal injury caused by unintentional activation of the system. For removal of Spiral Cable and Air Bag Module, see "SRS AIR BAG".
- Never use electrical test equipment on any circuit related to the SRS unless instructed to in this Service Manual. SRS wiring harnesses can be identified by yellow and/or orange harnesses or harness connectors.

#### PRECAUTIONS WHEN USING POWER TOOLS (AIR OR ELECTRIC) AND HAMMERS

#### **WARNING:**

Always observe the following items for preventing accidental activation.

- When working near the Air Bag Diagnosis Sensor Unit or other Air Bag System sensors with the ignition ON or engine running, never use air or electric power tools or strike near the sensor(s) with a hammer. Heavy vibration could activate the sensor(s) and deploy the air bag(s), possibly causing serious injury.
- When using air or electric power tools or hammers, always switch the ignition OFF, disconnect the battery, and wait at least 3 minutes before performing any service.

#### Precaution for Procedure without Cowl Top Cover

INFOID:000000012408297

When performing the procedure after removing cowl top cover, cover the lower end of windshield with urethane, etc to prevent damage to windshield.

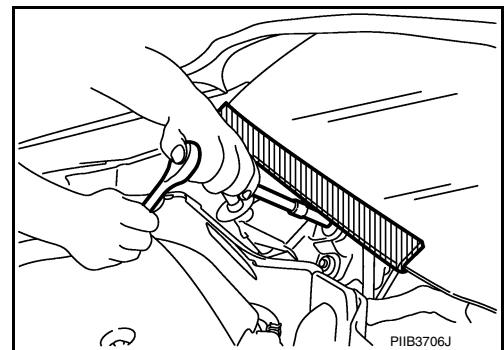

#### Precautions for Removing Battery Terminal

INFOID:000000013056750

When disconnecting the battery terminal, pay attention to the following.

- Always use a 12V battery as power source.
- Never disconnect battery terminal while engine is running.

# PRECAUTIONS

## < PRECAUTION >

- When removing the 12V battery terminal, turn OFF the ignition switch and wait at least 30 seconds.
- For vehicles with the engine listed below, remove the battery terminal after a lapse of the specified time:

D4D engine	: 20 minutes	YS23DDT	: 4 minutes
HRA2DDT	: 12 minutes	YS23DDTT	: 4 minutes
K9K engine	: 4 minutes	ZD30DDTi	: 60 seconds
M9R engine	: 4 minutes	ZD30DDTT	: 60 seconds
R9M engine	: 4 minutes		
V9X engine	: 4 minutes		
YD25DDTi	: 2 minutes		

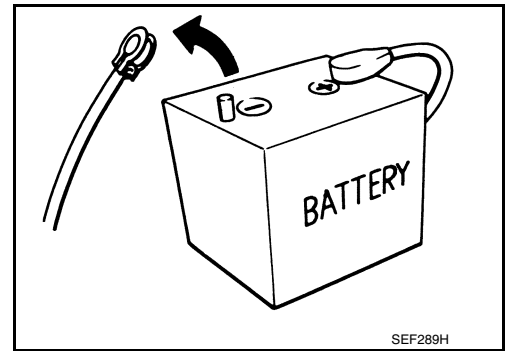

A

STR

C

D

E

F

G

H

I

J

K

L

M

N

O

P

### NOTE:

ECU may be active for several tens of seconds after the ignition switch is turned OFF. If the battery terminal is removed before ECU stops, then a DTC detection error or ECU data corruption may occur.

- After high-load driving, if the vehicle is equipped with the V9X engine, turn the ignition switch OFF and wait for at least 15 minutes to remove the battery terminal.

### NOTE:

- Turbocharger cooling pump may operate in a few minutes after the ignition switch is turned OFF.
- Example of high-load driving
  - Driving for 30 minutes or more at 140 km/h (86 MPH) or more.
  - Driving for 30 minutes or more on a steep slope.
- For vehicles with the 2-batteries, be sure to connect the main battery and the sub battery before turning ON the ignition switch.

### NOTE:

If the ignition switch is turned ON with any one of the terminals of main battery and sub battery disconnected, then DTC may be detected.

- After installing the 12V battery, always check "Self Diagnosis Result" of all ECUs and erase DTC.

### NOTE:

The removal of 12V battery may cause a DTC detection error.

## Precautions For Xenon Headlamp Service

INFOID:0000000012408298

### WARNING:

Comply with the following warnings to prevent any serious accident.

- Disconnect the battery cable (negative terminal) or the power supply fuse before installing, removing, or touching the xenon headlamp (bulb included). The xenon headlamp contains high-voltage generated parts.
- Never work with wet hands.
- Check the xenon headlamp ON-OFF status after assembling it to the vehicle. Never turn the xenon headlamp ON in other conditions. Connect the power supply to the vehicle-side connector. (Turning it ON outside the lamp case may cause fire or visual impairments.)
- Never touch the bulb glass immediately after turning it OFF. It is extremely hot.

### CAUTION:

Comply with the following cautions to prevent any error and malfunction.

- Install the xenon bulb securely. (Insufficient bulb socket installation may melt the bulb, the connector, the housing, etc. by high-voltage leakage or corona discharge.)
- Never perform HID circuit inspection with a tester.
- Never touch the xenon bulb glass with hands. Never put oil and grease on it.
- Dispose of the used xenon bulb after packing it in thick vinyl without breaking it.
- Never wipe out dirt and contamination with organic solvent (thinner, gasoline, etc.).

## Precautions When Battery Is Discharged

INFOID:0000000012408300

When battery is discharged, disconnect the negative terminal of the battery and wait for 1 minute before connecting jumper cables to restart the engine. (This is necessary for resetting information in ECM.)

# PREPARATION

< PREPARATION >

## PREPARATION

### PREPARATION

#### Special Service Tools

INFOID:000000012408301

Tool number (TechMate No.) Tool name	Description
<p>— (—) Model GR8-1200 NI Multitasking battery and electrical diagnostic station</p>  <p style="text-align: right;">AWIA1239ZZ</p>	<p>Tests batteries, starting and charging systems and charges batteries. For operating instructions, refer to diagnostic station instruction manual.</p>

#### Commercial Service Tools

INFOID:000000012408302

Tool name	Description
<p>Power tool</p>  <p style="text-align: right;">PIIB1407E</p>	<p>Loosening bolts, nuts and screws</p>

# COMPONENT PARTS

< SYSTEM DESCRIPTION >

## SYSTEM DESCRIPTION

### COMPONENT PARTS

#### Component Parts Location

INFOID:0000000012408303

A

STR

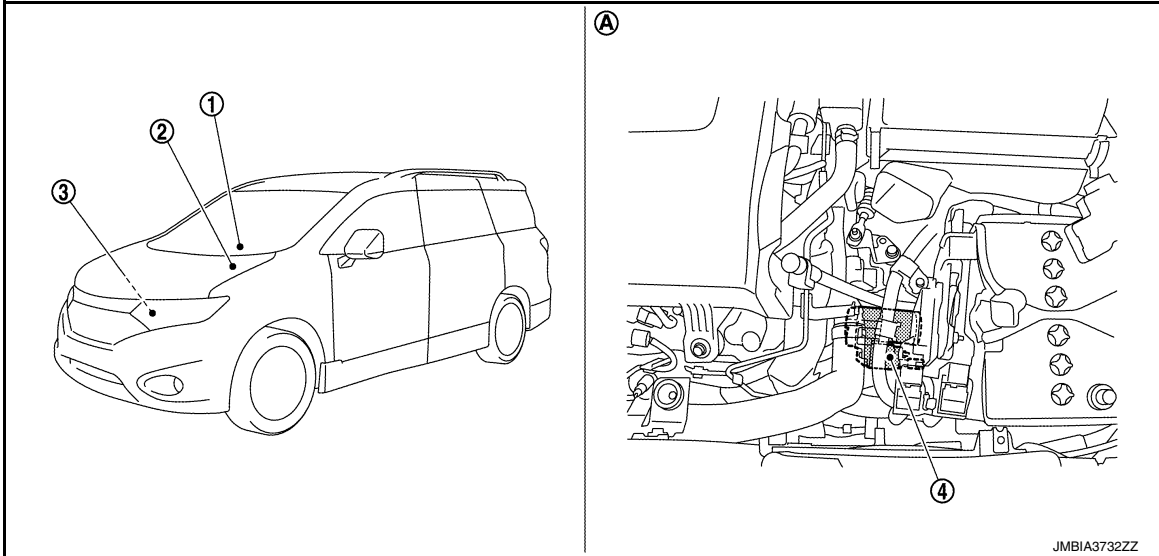

A. Engine room LH

C

D

E

F

G

H

I

J

K

L

M

N

O

P

No.	Component part	Description
1.	BCM	BCM controls the starter relay. Refer to <a href="#">BCS-5. "BODY CONTROL SYSTEM : Component Parts Location"</a> .
2.	IPDM E/R	CPU inside IPDM E/R controls the starter control relay. Refer to <a href="#">PCS-4. "IPDM E/R : Component Parts Location"</a> .
3.	Transmission range switch	When the selector lever is shifted to the "P" or "N" position, power is supplied to BCM and IPDM E/R (CPU) by transmission range switch.
4.	Starter motor	The starter motor plunger closes and the motor is supplied with battery power, which in turn cranks the engine, when the "S" terminal is supplied with electric power.

# SYSTEM

< SYSTEM DESCRIPTION >

## SYSTEM

### System Description

INFOID:000000012408304

### SYSTEM DIAGRAM

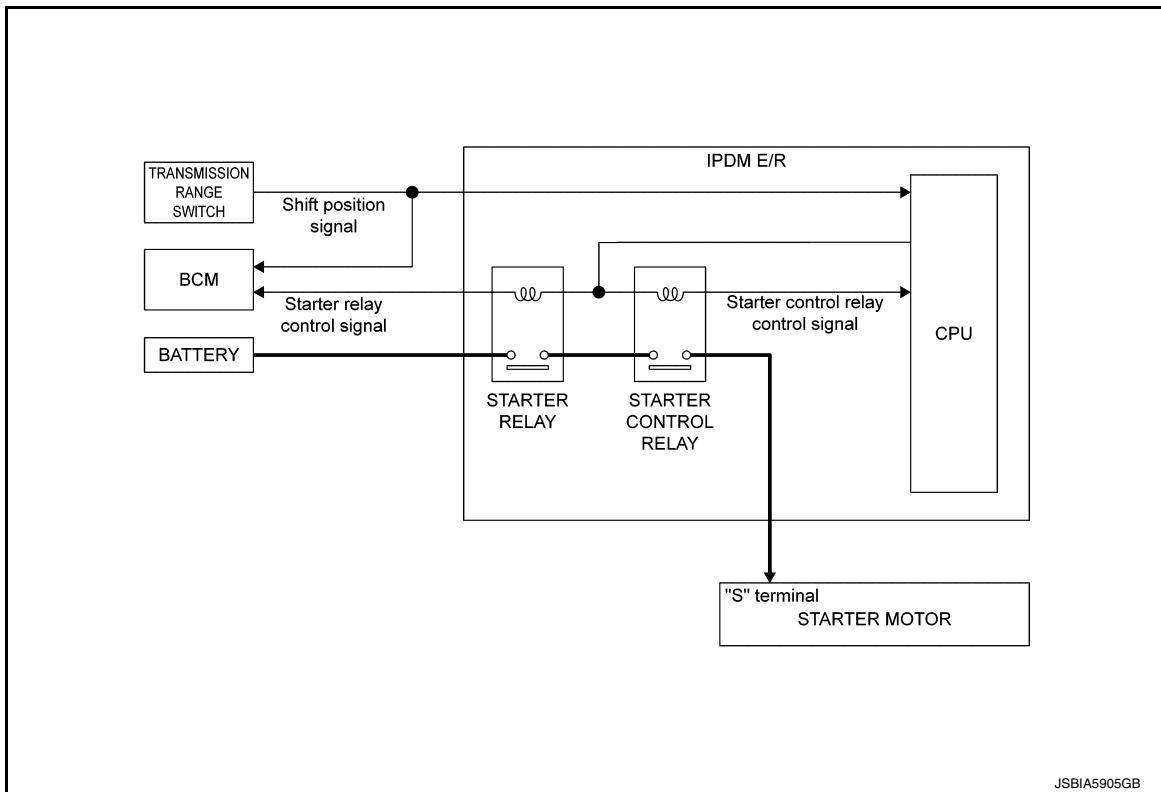

### OUTLINE

- When selector lever is "P" or "N", power is supplied to BCM and IPDM E/R (CPU) by transmission range switch. BCM and IPDM E/R (CPU) detect selector lever P/N condition by the inputted signal.
- When starter operating condition is satisfied, IPDM E/R turns starter control relay ON by starter control relay control signal.
- When engine cranking condition is satisfied, BCM turns starter relay ON by starter relay control signal.
- Then battery power is supplied to starter motor ("S" terminal) through starter control relay and starter relay.

# STARTING SYSTEM

< WIRING DIAGRAM >

## WIRING DIAGRAM

### STARTING SYSTEM

Wiring Diagram

INFOID:000000012408305

A

STR

C

D

E

F

G

H

I

J

K

L

M

N

O

P

STARTING SYSTEM

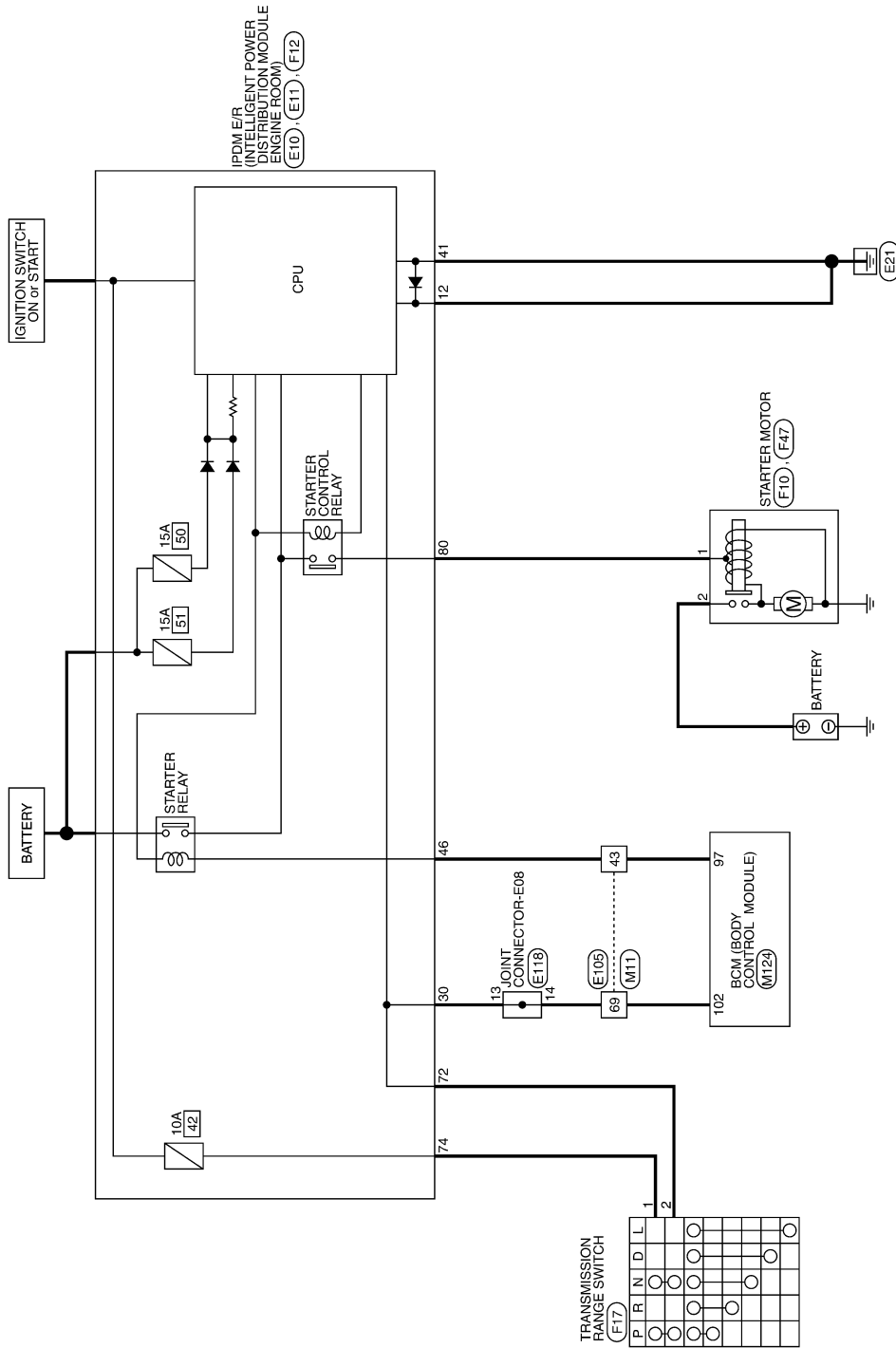

2015/09/04

JRBWD7683GB

# STARTING SYSTEM

< WIRING DIAGRAM >

## STARTING SYSTEM

Connector No.	FE10
Connector Name	POWER DISTRIBUTION MODULE ENGINE ROOM
Connector Type	THORN-C52-NM4-1V



1	13	14	15	16	17	18	19	20	21	22	23	24	25	26	27	28
4	5	6	7	8	9	10	11	12	13	14	15	16	17	18	19	20

Terminal No.	Color Of Wire	Signal Name [Specification]
4	LG	-
5	Y	-
7	BR	-
10	P	-
12	B	-
13	G	-
15	L	-
16	R	-
18	P	-
19	V	-
20	W	-
21	O	-
22	GR	-
23	GR	-
24	GR	-
25	GR	-
27	BR	-
28	GR	-
30	LG	-
34	O	-
35	P	-
36	G	-
38	GR	-

Connector No.	FE11
Connector Name	POWER DISTRIBUTION MODULE ENGINE ROOM
Connector Type	THORN-MNH



42	44	46	48
46	45	44	43

Terminal No.	Color Of Wire	Signal Name [Specification]
39	P	-
40	L	-
41	B	-
42	SB	-
43	LG	-
44	W	-
45	Y	-
46	O	-

Connector No.	FE105
Connector Name	WIRE TO WIRE
Connector Type	THORN-C510-M3



1	2	3	4	5	6	7	8	9	10	11	12	13	14	15	16	17	18	19	20	21	22	23	24	25	26	27	28	29	30	31	32	33	34	35	36	37	38	39	40	41	42	43	44	45	46	47	48	49	50	51	52	53	54	55	56	57	58	59	60	61	62	63	64	65	66	67	68	69	70	71	72	73	74	75	76	77	78	79	80	81	82	83
---	---	---	---	---	---	---	---	---	----	----	----	----	----	----	----	----	----	----	----	----	----	----	----	----	----	----	----	----	----	----	----	----	----	----	----	----	----	----	----	----	----	----	----	----	----	----	----	----	----	----	----	----	----	----	----	----	----	----	----	----	----	----	----	----	----	----	----	----	----	----	----	----	----	----	----	----	----	----	----	----	----	----

Terminal No.	Color Of Wire	Signal Name [Specification]
1	SHIELD	-
2	W	-
3	B	-
4	R	-
6	LG	-
7	R	-
8	GR	-
9	V	-
10	BR	-
11	Y	-
12	O	-

Connector No.	FE18
Connector Name	JOINT CONNECTOR-EB8
Connector Type	BUDEN



1	10	19	28	37	46	55	64	73	82	91	100	109	118	127	136	145	154	163	172	181	190	199	208	217	226	235	244	253	262	271	280	289	298	307	316	325	334	343	352	361	370	379	388	397	406	415	424	433	442	451	460	469	478	487	496	505	514	523	532	541	550	559	568	577	586	595	604	613	622	631	640	649	658	667	676	685	694	703	712	721	730	739	748	757	766	775	784	793	802	811	820	829	838	847	856	865	874	883	892	901	910	919	928	937	946	955	964	973	982	991	1000
---	----	----	----	----	----	----	----	----	----	----	-----	-----	-----	-----	-----	-----	-----	-----	-----	-----	-----	-----	-----	-----	-----	-----	-----	-----	-----	-----	-----	-----	-----	-----	-----	-----	-----	-----	-----	-----	-----	-----	-----	-----	-----	-----	-----	-----	-----	-----	-----	-----	-----	-----	-----	-----	-----	-----	-----	-----	-----	-----	-----	-----	-----	-----	-----	-----	-----	-----	-----	-----	-----	-----	-----	-----	-----	-----	-----	-----	-----	-----	-----	-----	-----	-----	-----	-----	-----	-----	-----	-----	-----	-----	-----	-----	-----	-----	-----	-----	-----	-----	-----	-----	-----	-----	-----	-----	-----	-----	------

Terminal No.	Color Of Wire	Signal Name [Specification]
1	L	-
2	L	-
3	L	-
6	Y	-
7	Y	-
8	Y	-
9	Y	-
10	Y	-
11	Y	-
12	R	-
13	R	-
14	R	-
15	V	-
16	V	-
17	V	-
18	V	-
19	L	-
20	L	-
21	L	-
22	L	-
23	SB	-
24	SB	-
25	BR	-
26	BR	-
27	R	-
28	R	-
29	B/V	-
30	B/V	-
32	P	-
33	P	-

Terminal No.	Color Of Wire	Signal Name [Specification]
13	W	-
14	P	-
15	P	-
31	GR	-
32	V	-
37	BR	-
38	GR	-
39	GR	-
40	P	-
41	L	-
42	LG	-
43	O	-
45	P	-
46	SB	-
47	V	-
49	L	-
51	BR	-
52	G	-
53	B	-
54	O	-
55	Y	-
56	SHIELD	-
61	P	-
62	G	-
63	W/L	-
64	W/R	-
65	W	-
66	R	-
67	R	-
68	R	-
69	R	-
70	L	-
71	L	-
72	GR	-
73	L	-
74	Y	-
75	SB	-
76	Y	-
77	G	-
78	O	-
80	R	-
81	L	-
82	LG	-
83	R	-



# STARTING SYSTEM

< WIRING DIAGRAM >

A  
STR  
C  
D  
E  
F  
G  
H  
I  
J  
K  
L  
M  
N  
O  
P

## STARTING SYSTEM

Connector No.	F10
Connector Name	STARTER MOTOR
Connector Type	25-340_1A66A



Terminal No.	Color Of Wire	Signal Name [Specification]
2	B/R	-

Connector No.	F12
Connector Name	IPM (IPM) INTELLIGENT POWER DISTRIBUTION MODULE (ENGINE STOP)
Connector Type	TH40FW-CS12-M4



Terminal No.	Color Of Wire	Signal Name [Specification]
48	R/B	-
49	R/B	-
51	LG	-
52	Y/G	-
53	B/W	-
54	G/W	-
55	W/L	-
56	R/Y	-
57	O	-
58	Y	-
69	W/B	-
70	O	-
71	P	-
72	R/B	-
74	LG	-
76	GR	-
77	B	-
80	B	-

Connector No.	F17
Connector Name	TRANSMISSION RANGE SWITCH
Connector Type	YD008F#1H54

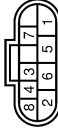

Terminal No.	Color Of Wire	Signal Name [Specification]
1	LG	-
2	R/B	-
3	LG	-
4	BR/W	-
5	P/B	-
6	P/L	-
7	G/O	-
8	GR	-

Connector No.	F47
Connector Name	STARTER MOTOR
Connector Type	X014GY



Terminal No.	Color Of Wire	Signal Name [Specification]
1	B	-

Connector No.	M11
Connector Name	WIRE TO WIRE
Connector Type	TH70FW-CS10-M3

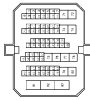

Terminal No.	Color Of Wire	Signal Name [Specification]
1	SHIELD	-
2	W	-
3	B	-
4	R	-
6	G	-
7	R	-
8	G	-
9	B	-
10	R	-
11	W	-
12	L	- [Without automatic drive positioner]
12	LG	- [With automatic drive positioner]
13	G	- [Without automatic drive positioner]
13	Y	- [With automatic drive positioner]
14	L	-
15	R	-
16	P	-
31	LG	- [With automatic drive positioner]
32	LG	- [Without automatic drive positioner]
37	BR	- [With automatic drive positioner]
37	R	- [Without automatic drive positioner]
38	R	-
39	BE	- [Without automatic drive positioner]
40	P	- [With automatic drive positioner]
41	L	-
42	G	-
43	L	-
45	P	-
46	V	-
47	R	-
49	G	-
51	G	-
52	W	-
53	B	-
54	LG	-
55	L	-

56	SHIELD	-
61	R	-
62	R	-
63	W	-
66	W	-
67	BR	-
69	P	-
71	R	-
72	L	-
73	LG	-
74	Y	-
75	Y	-
76	V	-
77	P	-
78	BR	-
80	Y	-
81	W	-
82	L	-
83	R	-

Connector No.	M124
Connector Name	BCM (BODY CONTROL MODULE)
Connector Type	TH40FW-NH



Terminal No.	Color Of Wire	Signal Name [Specification]
73	G	ON/IND
75	G	DR DOOR REQ SW
76	V	PUSH SW
78	B	DR DOOR ANT+
79	W	DR DOOR ANT-
80	GR	PASS DOOR ANT+
81	BE	PASS DOOR ANT-
82	G	REAR BIMP ANT+
83	R	REAR BIMP ANT-
84	GR	ROOM ANT+
85	B	ROOM ANT-
86	W	ROOM ANT+
87	BE	ROOM ANT-
88	GR	Luggage ROOM ANT+

# STARTING SYSTEM

< WIRING DIAGRAM >

STARTING SYSTEM		
88	B	LAGGAGE INDICANT
89	W	PUSH-BTN IGN SW 1/1 PWR SPLY
91	W	LOCK PLUS
92	R	PUSH-BTN IGN SW 1/1 GND
93	R	KEY/MARKER/FEEDER
96	BE	ACC RELAY CONT OUTPUT
97	W	STARTER RELAY CONT
98	P	IGN RELAY (F/B) CONT
99	G	IGN RELAY (F/B) CONT OUTPUT
100	R	PASS DOOR RECS SW
101	R	IGN PWR SPLY 2
102	P	P/N POSITION
104	L	CVT SHIFT SELECT PWR SPLY
105	R	STOP LAMP SW 2
106	O	BLWR RELAY CONT OUTPUT
109	R	ACC IND

JRBWD7686GB

# DIAGNOSIS AND REPAIR WORK FLOW

< BASIC INSPECTION >

## BASIC INSPECTION

### DIAGNOSIS AND REPAIR WORK FLOW

Work Flow (With GR8-1200 NI)

INFOID:0000000012408306

A

STR

#### STARTING SYSTEM DIAGNOSIS WITH GR8-1200 NI

To test the starting system, use the following special service tool:

- GR8-1200 NI Multitasking battery and electrical diagnostic station

**NOTE:**

Refer to the diagnostic station Instruction Manual for proper starting system diagnosis procedures.

C

D

E

F

G

H

I

J

K

L

M

N

O

P

# DIAGNOSIS AND REPAIR WORK FLOW

< BASIC INSPECTION >

## OVERALL SEQUENCE

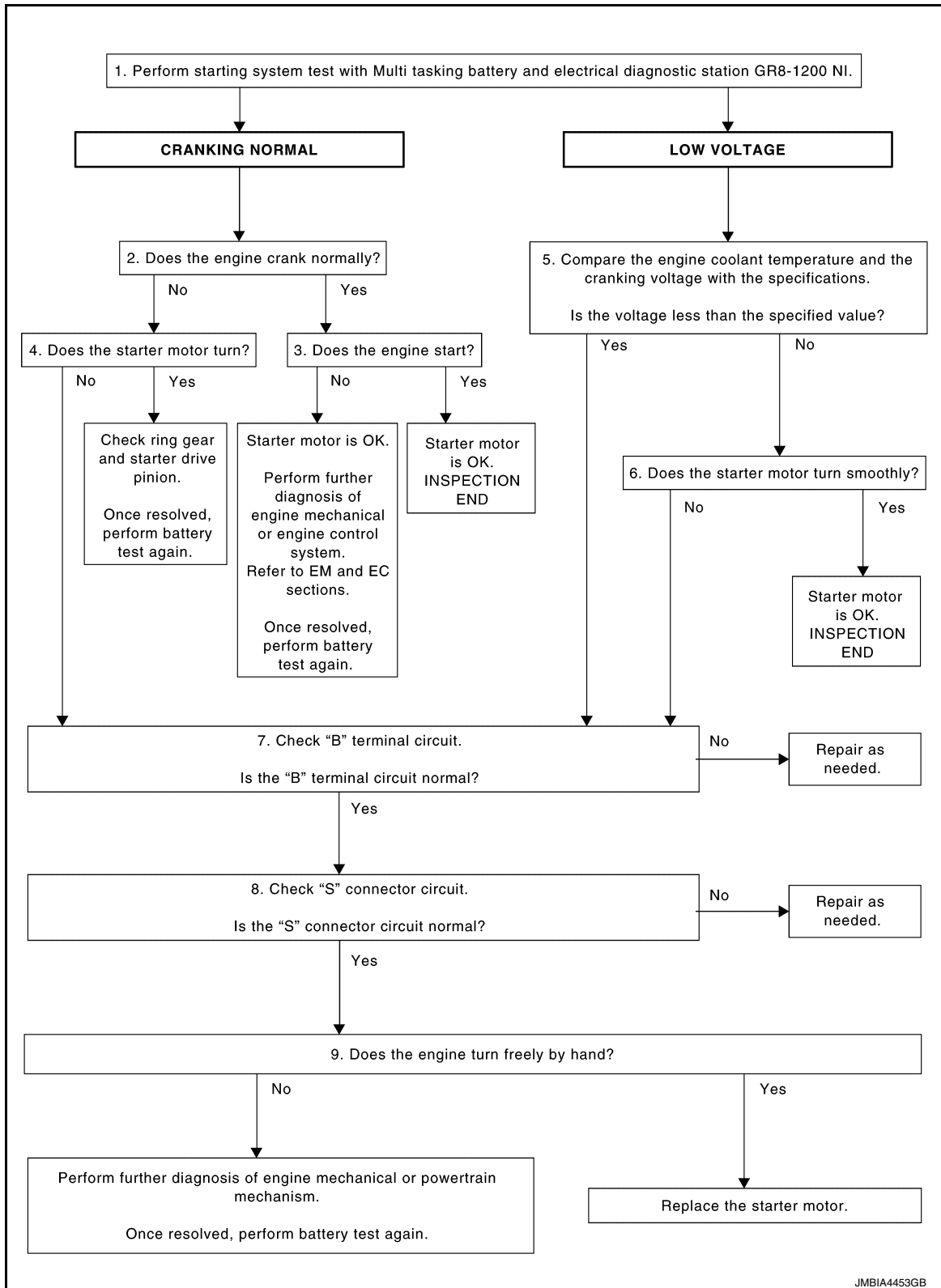

### DETAILED FLOW

#### NOTE:

To ensure a complete and thorough diagnosis, the battery, starter motor and alternator test segments must be done as a set from start to finish.

#### 1. DIAGNOSIS WITH MULTITASKING BATTERY AND ELECTRICAL DIAGNOSTIC STATION GR8-1200 NI

# DIAGNOSIS AND REPAIR WORK FLOW

## < BASIC INSPECTION >

Perform the starting system test with Multitasking battery and electrical diagnostic station GR8-1200 NI. For details and operating instructions, refer to diagnostic station Instruction Manual.

### Test result

CRANKING NORMAL>>GO TO 2.

LOW VOLTAGE>>GO TO 5.

CHARGE BATTERY>>Perform the slow battery charging procedure. (Initial rate of charge is 10A for 12 hours.) Perform battery test again. Refer to diagnostic station instruction manual.

REPLACE BATTERY>>Before replacing battery, clean the battery cable clamps and battery posts. Perform battery test again. Refer to diagnostic station instruction manual. If second test result is "REPLACE BATTERY", then do so. Perform battery test again to confirm repair.

## 2. CRANKING CHECK

Check that the starter motor operates correctly.

### Does the engine crank normally?

YES >> GO TO 3.

NO >> GO TO 4.

## 3. ENGINE START CHECK

Check that the engine starts.

### Does the engine start?

YES >> Starter motor is OK. INSPECTION END

NO >> Perform further diagnosis of engine mechanical or engine control system. Refer EM and EC sections. Once resolved, perform battery test again.

## 4. STARTER MOTOR ACTIVATION

Check that the starter motor operates.

### Does the starter motor turn?

YES >> Check ring gear and starter motor drive pinion. Once resolved, perform battery test again.

NO >> GO TO 7.

## 5. COMPARISON BETWEEN ENGINE COOLANT AND CRANKING VOLTAGE

Compare the engine coolant temperature and the cranking voltage with the specifications.

### Minimum Specification of Cranking Voltage Referencing Coolant Temperature

Engine coolant temperature [°C (°F)]	Voltage [V]
-30 to -20 (-22 to -4)	8.6
-19 to -10 (-2 to 14)	9.1
-9 to 0 (16 to 32)	9.5
More than 1 (More than 34)	9.9

### Is the voltage less than the specified value?

YES >> GO TO 7.

NO >> GO TO 6.

## 6. STARTER OPERATION

Check the starter operation status.

### Does the starter motor turn smoothly?

YES >> Starter motor is OK. INSPECTION END

NO >> GO TO 7.

## 7. "B" TERMINAL CIRCUIT INSPECTION

Check "B" terminal circuit. Refer to [STR-16, "Diagnosis Procedure"](#).

### Is "B" terminal circuit normal?

YES >> GO TO 8.

NO >> Repair as needed.

## 8. "S" CONNECTOR CIRCUIT INSPECTION

Check "S" connector circuit. Refer to [STR-17, "Diagnosis Procedure"](#).

# DIAGNOSIS AND REPAIR WORK FLOW

## < BASIC INSPECTION >

### Is "S" connector circuit normal?

- YES >> GO TO 9.
- NO >> Repair as needed.

## 9. ENGINE ROTATION STATUS

Check that the engine can be rotated by hand.

### Does the engine turn freely by hand?

- YES >> Replace starter motor. Refer to [STR-19. "Removal and Installation"](#).
- NO >> Perform further diagnosis of engine mechanical or powertrain mechanism. Once resolved, perform battery test again using Multitasking battery and electrical diagnostic station GR8-1200 NI. Refer to the diagnostic station Instruction Manual for proper testing procedures.

## Work Flow (Without GR8-1200 NI)

INFOID:000000012408307

## OVERALL SEQUENCE

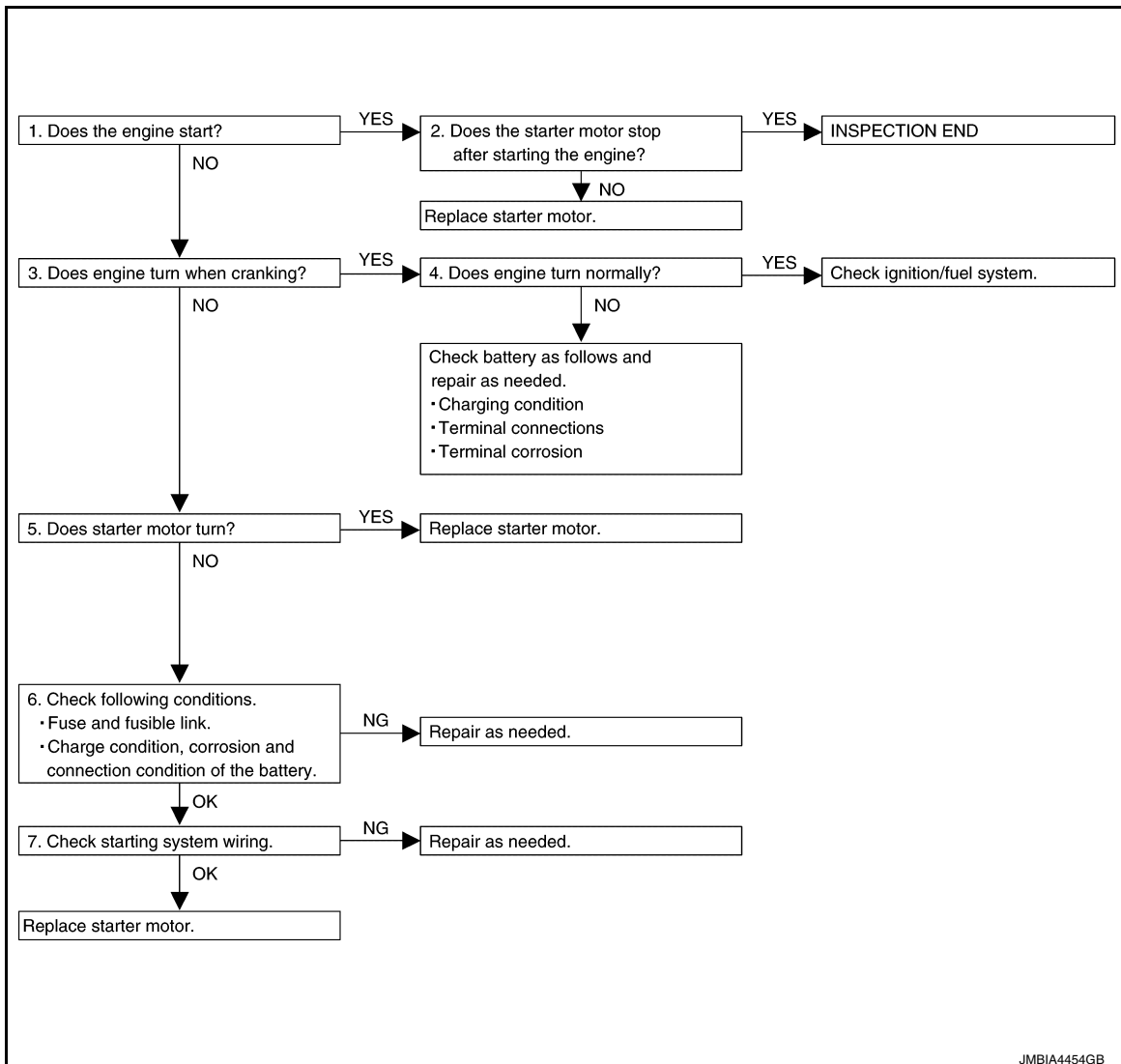

## DETAILED FLOW

### NOTE:

If any malfunction is found, immediately disconnect the battery cable from the negative terminal.

## 1. CHECK ENGINE START

Crank the engine and check that the engine starts.

### Does the engine start?

- YES >> GO TO 2.

# DIAGNOSIS AND REPAIR WORK FLOW

## < BASIC INSPECTION >

---

NO >> GO TO 3.

### 2.CHECK THAT THE STARTER MOTOR STOPS

---

Check that the starter motor stops after starting the engine.

Does the starter motor stop?

YES >> INSPECTION END

NO >> Replace starter motor. Refer to [STR-19. "Removal and Installation"](#).

### 3.CHECK THAT THE ENGINE TURNS WHEN CRANKING

---

Check that the engine turns when cranking.

Does engine turn when cranking?

YES >> GO TO 4.

NO >> GO TO 5.

### 4.CHECK THE ENGINE SPEED WHEN CRANKING

---

Check that the engine speed is not low when cranking.

Does engine turn normally?

YES >> Check ignition/fuel system.

NO >> Check charge condition, corrosion and connection condition of the battery. Refer to [PG-128. "Work Flow"](#).

### 5.CHECK STARTER MOTOR ACTIVATION

---

Check that the starter motor runs at cranking.

Does starter motor turn?

YES >> Replace starter motor. Refer to [STR-19. "Removal and Installation"](#).

NO >> GO TO 6.

### 6.CHECK POWER SUPPLY CIRCUIT

---

Check the following conditions.

- Fuse and fusible link
- Charge condition, corrosion and connection condition of the battery. Refer to [PG-128. "Work Flow"](#).

Are these inspection results normal?

YES >> GO TO 7.

NO >> Repair as needed.

### 7.CHECK STARTING SYSTEM WIRING

---

Check the following.

- "B" terminal circuit. Refer to [STR-16. "Diagnosis Procedure"](#).
- "S" connector circuit. Refer to [STR-17. "Diagnosis Procedure"](#).

Are these inspection results normal?

YES >> Replace starter motor. Refer to [STR-19. "Removal and Installation"](#).

NO >> Repair as needed.

A

STR

C

D

E

F

G

H

I

J

K

L

M

N

O

P

# B TERMINAL CIRCUIT

< DTC/CIRCUIT DIAGNOSIS >

## DTC/CIRCUIT DIAGNOSIS

### B TERMINAL CIRCUIT

#### Description

INFOID:0000000012408308

The "B" terminal is constantly supplied with battery power.

#### Diagnosis Procedure

INFOID:0000000012408309

#### CAUTION:

Perform diagnosis under the condition that engine cannot start by the following procedure.

1. Remove fuel pump fuse.
2. Crank or start the engine (where possible) until the fuel pressure is released.

#### 1. CHECK "B" TERMINAL CIRCUIT

1. Turn ignition switch OFF.
2. Check that starter motor "B" terminal connection is clean and tight.
3. Check voltage between starter motor "B" terminal and ground.

Terminals		Voltage (Approx.)
(+)	(-)	
Starter motor "B" terminal	Terminal	Battery voltage
F10	2	
	Ground	

Is the inspection result normal?

- YES >> GO TO 2.  
NO >> Check harness between battery and starter motor for open circuit.

#### 2. CHECK BATTERY CABLE CONNECTION STATUS (VOLTAGE DROP TEST)

1. Shift selector lever to "P" or "N" position.
2. Check voltage between battery positive terminal and starter motor "B" terminal.

Terminals		Condition	Voltage (Approx.)
(+)	(-)		
	Starter motor "B" terminal	When the ignition switch is in START position	Less than 0.5 V
Battery positive terminal	F10		
	Terminal		
	2		

Is the inspection result normal?

- YES >> GO TO 3.  
NO >> Check harness between the battery and the starter motor for poor continuity.

#### 3. CHECK GROUND CIRCUIT STATUS (VOLTAGE DROP TEST)

1. Shift selector lever to "P" or "N" position.
2. Check voltage between starter motor case and battery negative terminal.

Terminals		Condition	Voltage (Approx.)
(+)	(-)		
Starter motor case	Battery negative terminal	When the ignition switch is in START position	Less than 0.2 V

Is the inspection result normal?

- YES >> "B" terminal circuit is OK. Further inspection is necessary. Refer to [STR-11, "Work Flow \(With GR8-1200 NI\)"](#) or [STR-14, "Work Flow \(Without GR8-1200 NI\)"](#).  
NO >> Check the starter motor case and ground for poor continuity.



# S CONNECTOR CIRCUIT

< DTC/CIRCUIT DIAGNOSIS >

## S CONNECTOR CIRCUIT

### Description

INFOID:000000012408310

The starter motor magnetic switch is supplied with power when the ignition switch is turned to the START position while the selector lever is in the P or N position.

STR

### Diagnosis Procedure

INFOID:000000012408311

#### CAUTION:

Perform diagnosis under the condition that engine cannot start by the following procedure.

1. Remove fuel pump fuse.
2. Crank or start the engine (where possible) until the fuel pressure is released.

#### 1. CHECK "S" CONNECTOR CIRCUIT

1. Turn ignition switch OFF.
2. Disconnect starter motor connector.
3. Shift selector lever to "P" or "N" position.
4. Check voltage between starter motor harness connector and ground.

terminals		(-)	Condition	Voltage (Approx.)
(+)	Terminal			
Starter motor harness connector				
F47	1	Ground	When the ignition switch is in START position	Battery voltage

#### Is the inspection result normal?

YES >> "S" connector circuit is OK. Further inspection is necessary. Refer to [STR-11, "Work Flow \(With GR8-1200 NI\)"](#) or [STR-14, "Work Flow \(Without GR8-1200 NI\)"](#).

NO >> GO TO 2.

#### 2. CHECK HARNESS CONTINUITY (OPEN CIRCUIT)

1. Disconnect IPDM E/R connector.
2. Check continuity between starter motor harness connector and IPDM E/R harness connector.

Starter motor harness connector		IPDM E/R harness connector		Continuity
Connector No.	Terminal No.	Connector No.	Terminal No.	
F47	1	F12	80	Existed

#### Is the inspection result normal?

YES >> Further inspection is necessary. Refer to [STR-11, "Work Flow \(With GR8-1200 NI\)"](#) or [STR-14, "Work Flow \(Without GR8-1200 NI\)"](#).

NO >> Repair the harness.

# STARTING SYSTEM

< SYMPTOM DIAGNOSIS >

## SYMPTOM DIAGNOSIS

### STARTING SYSTEM

#### Symptom Table

INFOID:000000012408312

Symptom	Reference
No normal cranking	Refer to <a href="#">STR-11. "Work Flow (With GR8-1200 NI)"</a> or <a href="#">STR-14. "Work Flow (Without GR8-1200 NI)"</a> .
Starter motor does not rotate	

# STARTER MOTOR

< REMOVAL AND INSTALLATION >

## REMOVAL AND INSTALLATION

### STARTER MOTOR

Exploded View

INFOID:000000012408313

A  
STR

#### REMOVAL

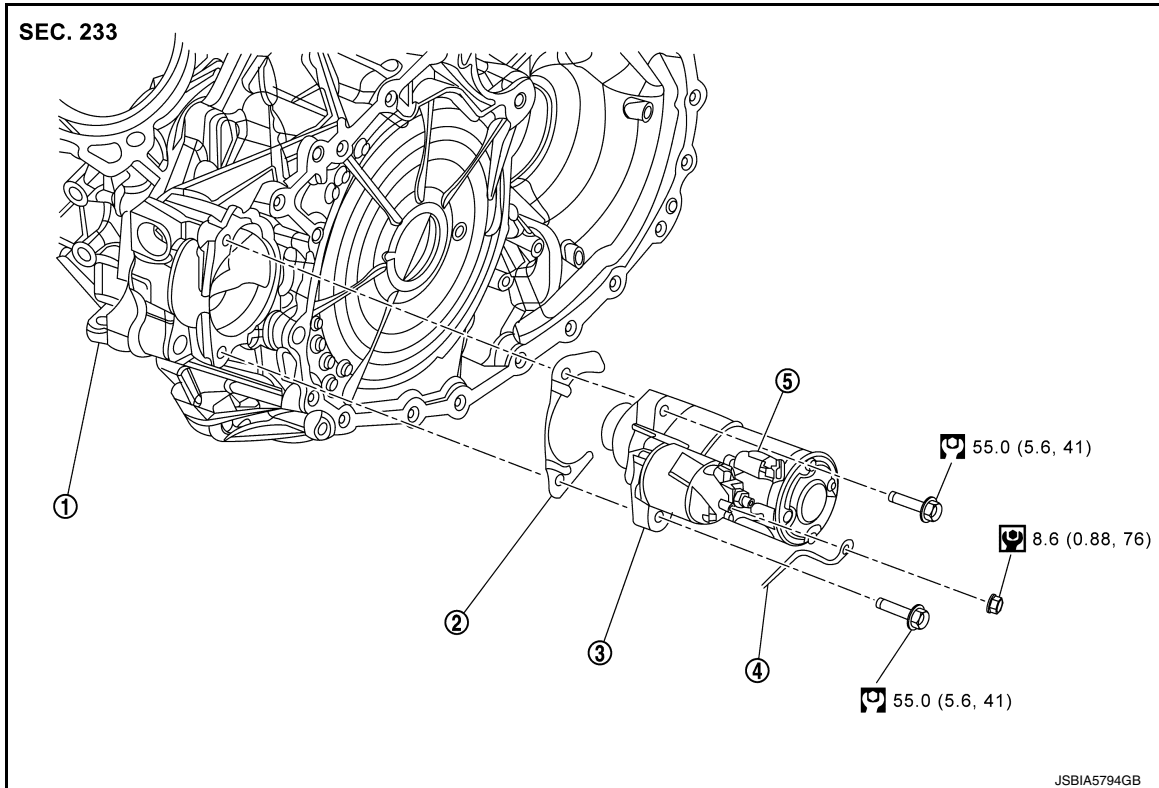

C  
D  
E  
F  
G  
H  
I  
J

- |                         |                  |                  |
|-------------------------|------------------|------------------|
| 1. Cylinder block       | 2. Shim          | 3. Starter motor |
| 4. "B" terminal harness | 5. "S" connector |                  |

: N·m (kg-m, in-lb)

: N·m (kg-m, ft-lb)

K  
L

#### Removal and Installation

INFOID:000000012408314

#### REMOVAL

1. Remove battery. Refer to [PG-136, "Removal and Installation"](#).
2. Remove air duct (inlet) and air cleaner assembly. Refer to [EM-27, "Removal and Installation"](#).
3. Disconnect TCM harness connector (1) and ECM harness connectors (2).

: Vehicle front

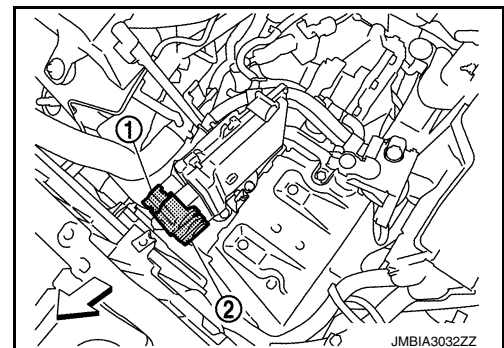

M  
N  
O  
P

# STARTER MOTOR

## < REMOVAL AND INSTALLATION >

4. Remove harness fixing clips (A) and harness mounting bolt (B).

↔ : Vehicle front

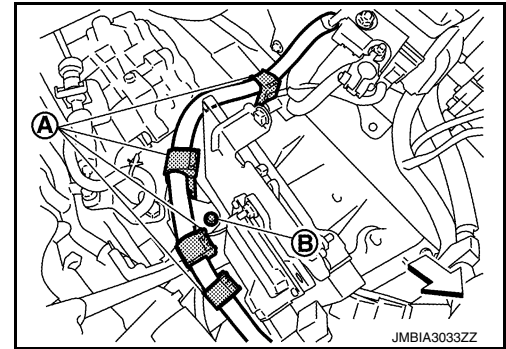

5. Remove ECM bracket mounting bolts (A), and then remove ECM bracket (1).

↔ : Vehicle front

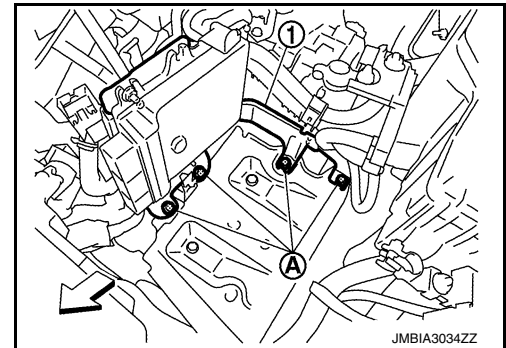

6. Remove battery tray mounting bolts (A), and then remove battery tray (1).

↔ : Vehicle front

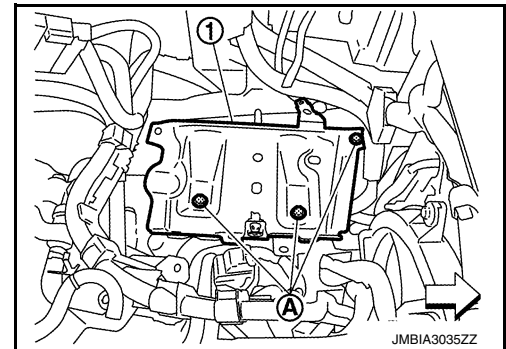

7. Disconnect "S" terminal harness connector.
8. Remove "B" terminal harness nut, and then disconnect "B" terminal harness.
9. Remove splash guard LH. Refer to [EXT-23, "Removal and Installation"](#).
10. Remove starter motor mounting bolts from the left side of the vehicle and the engine room.
11. Remove starter motor from the vehicle.

## INSTALLATION

Note the following items, and install in the reverse order of removal.

### CAUTION:

- Be careful to tighten "B" terminal nut to the specified torque.
- To prevent damage to the parts, connect the battery cable to the positive terminal first.
- To prevent damage to the vehicle, after connecting battery cables, ensure that they are tightly clamped to battery terminals for good contact.
- To prevent damage to the parts, check battery terminal for poor connection caused by corrosion.

### NOTE:

Reset electronic systems as necessary. Refer to [GI-59, "ADDITIONAL SERVICE WHEN REMOVING BATTERY NEGATIVE TERMINAL : Required Procedure After Battery Disconnection"](#).

# SERVICE DATA AND SPECIFICATIONS (SDS)

< SERVICE DATA AND SPECIFICATIONS (SDS)

## SERVICE DATA AND SPECIFICATIONS (SDS)

SERVICE DATA AND SPECIFICATIONS (SDS)

Starter Motor

INFOID:0000000012408315

A

STR

Type	M000TB0271		
	MITSUBISHI make		
	Reduction gear type		
System voltage	[V]	12	
No-load	Terminal voltage	[V]	11
	Current	[A]	Less than 90
	Revolution	[rpm]	More than 2,370

C

D

E

F

G

H

I

J

K

L

M

N

O

P