

**SECTION BF**

GI  
MA  
EM  
LG  
EF &  
EC

**CONTENTS**

<b>GENERAL SERVICING</b> .....	2	Interior .....	31
Precautions .....	2	Roof Trim .....	35
Supplemental Restraint System Supplemental “AIR BAG” .....	2	Exterior .....	37
Circuit Breaker Inspection .....	2	① Hood front sealing rubber .....	38
Clip and Fastener .....	3	② ③ Hood rear sealing rubber & cowl top grille .....	38
<b>BODY END</b> .....	6	④ Sun roof frame weatherstrip and sun roof lid weatherstrip .....	38
Body Front End .....	6	⑤ Windshield upper molding .....	38
Removal — Front bumper assembly .....	6	⑥ Windshield side molding .....	38
Bumper Shock Absorber Inspection — Front .....	9	⑦ Body side drip molding .....	39
Body Rear End and Opener .....	10	⑧ Waist rail finisher .....	39
Removal — Rear bumper assembly .....	10	⑨ Front door weatherstrip .....	39
Bumper Shock Absorber Inspection — Rear ...	10	⑩ Sliding door weatherstrip .....	39
<b>DOOR</b> .....	13	⑪ Sliding door lower seal .....	39
Front Door .....	13	⑫ Back door opening weatherstrip .....	39
Sliding Door .....	14	⑬ Luggage rack .....	40
<b>POWER DOOR LOCK</b> .....	16	⑭ Outside door molding .....	41
System Description .....	16	⑮ Front door corner covers .....	42
Wiring Diagram —D/LOCK— .....	18	⑯ Side guard molding .....	42
Trouble Diagnoses .....	20	<b>SEAT</b> .....	43
Sliding Door Lock Delay Operation .....	20	Front Seat .....	43
Door Lock Timer Inspection .....	20	Front Power Seat .....	44
Electrical Components Inspection .....	21	Front Power Seat/System Description .....	45
Sliding door switch .....	21	Front Power Seat/Wiring Diagram —SEAT— .....	46
Lock knob switch (built into driver side door lock actuator) .....	21	2nd Seat .....	48
Lock and unlock switch .....	21	Type I .....	48
Door lock actuator .....	21	Type II .....	49
<b>POWER WINDOW</b> .....	22	3rd Seat .....	50
System Description .....	22	Third Sliding Seat Rails .....	51
Wiring Diagram —WINDOW— .....	24	<b>AUTOMATIC SEAT BELT SYSTEM</b> .....	56
Trouble Diagnoses .....	27	Unit Location .....	56
Power Window Amp. Inspection .....	27	Removal and Installation .....	57
<b>INSTRUMENT PANEL</b> .....	28	Shoulder Belt Buckle Drive Motor .....	57
Removal — Instrument panel assembly .....	28	Wiring Diagram —S/BELT— .....	58
Installation .....	28	Description .....	61
<b>INTERIOR AND EXTERIOR</b> .....	31		

FE  
AT  
FA  
RA  
BR  
ST

**BF**

HA  
EL  
IDX

# CONTENTS (Cont'd.)

## AUTOMATIC SEAT BELT SYSTEM — Trouble

<b>Diagnoses</b> .....	63
Symptom Chart .....	64
Preliminary Check .....	65
Procedure 1 .....	65
Procedure 2 .....	67
Main Power Supply and Ground Circuit Check .....	69
Procedure 1 .....	69
Main power supply .....	69
Ground circuit .....	69
Procedure 2 .....	69
Power supply for drive motor .....	69
Ground circuit for drive motor .....	69
Harness Layout .....	70
Circuit Diagram for Quick Pinpoint Check .....	72
Diagnostic Procedure 1 .....	73
Diagnostic Procedure 2 .....	76
Diagnostic Procedure 3 .....	78
Diagnostic Procedure 4 .....	80
Diagnostic Procedure 5 .....	82
Diagnostic Procedure 6 .....	84
Diagnostic Procedure 7 .....	85
Diagnostic Procedure 8 .....	86
Diagnostic Procedure 9 .....	87
Diagnostic Procedure 10 .....	88
Electrical Components Inspection .....	89
Front Limit Switch .....	89
Rear Limit Switch .....	89
Shoulder Belt Retractor Switch .....	89
Door Latch Switch (Built-in door lock assembly) .....	89
Drive Motor Assembly .....	89
Lap Belt Buckle Switch (Built-in lap belt buckle for LH side) .....	90
<b>THREE POINT TYPE SEAT BELTS</b> .....	91
<b>SUN ROOF</b> .....	92
Removal And Installation .....	92
Disassembly And Assembly — Guide rail assembly .....	92
Removal And Installation — Sun roof drain hoses .....	92
System Description .....	95
Wiring Diagram —SROOF— .....	96
<b>WINDSHIELD AND WINDOWS</b> .....	97
Windshield/Back Door Window .....	97
Repairing Water Leaks .....	97
Side Window (1st) .....	98
Side Window (2nd) .....	99
Installation .....	99
<b>MIRROR</b> .....	100
Door Mirror .....	100

Removal .....	100
Wiring Diagram —MIRROR— .....	101
Rearview Mirror .....	102
Removal .....	102
Installation .....	102
<b>BODY ALIGNMENT</b> .....	103
Engine Compartment .....	104
Measurement .....	104
Measurement Points .....	105
Underbody .....	106
Measurement .....	106
Measurement Points .....	107
<b>SUPPLEMENTAL RESTRAINT SYSTEM (SRS)</b> .....	109
Precautions for SRS Supplemental “Air Bag” Service .....	109
Special Service Tools .....	109
Commercial Service Tools .....	109
Description .....	110
Self-diagnosis .....	110
SRS Component Parts Location and Caution Labels .....	111
Caution Labels .....	112
Maintenance Items .....	114
Removal and Installation — Diagnosis (Control) Unit and Sensors .....	115
Removal — Supplemental Air Bag Module and Spiral Cable .....	116
Installation — Supplemental Air Bag Module and Spiral Cable .....	118
Scrapping the Supplemental Air Bag .....	119
Connecting To Battery .....	119
Deployment Tool Check .....	119
Supplemental Air Bag Deployment Tool Lamp Illumination Chart .....	119
Connecting To Supplemental Air Bag .....	120
Deployment .....	120
Disposal .....	120
<b>TROUBLE DIAGNOSES — Supplemental Restraint System (SRS)</b> .....	121
Schematic .....	121
Wiring Diagram —SRS— .....	121
Self-diagnosis .....	124
Using CONSULT .....	124
Self-diagnosis results .....	125
Using The Warning Lamp .....	126
Diagnostic Procedure 1 .....	129
Diagnostic Procedure 2 .....	129
Diagnostic Procedure 3 .....	130
Collision Diagnosis .....	131

# CONTENTS (Cont'd.)

When you read wiring diagrams:

- Read GI section, "HOW TO READ WIRING DIAGRAMS".
- See EL section, "POWER SUPPLY ROUTING" for power distribution circuit.

When you perform trouble diagnoses, read GI section, "HOW TO FOLLOW FLOW CHART IN TROUBLE DIAGNOSES".

★ For additional seat belt inspection information, refer to MA section.

GI

MA

EM

LC

EF &  
EC

FE

AT

FA

RA

BR

ST

**BF**

HA

EL

IDX

## Precautions

- When removing or installing various parts, place a cloth or padding on the vehicle body to prevent scratches.
- Handle trim, molding, instruments, grille, etc. carefully during removing or installation. Be careful not to soil or damage them.
- Apply sealing compound where necessary when installing parts.
- When applying sealing compound, be careful that the sealing compound does not protrude from parts.
- When replacing any metal parts (for example body outer panel, members, etc.), be sure to take rust prevention measures.

## Supplemental Restraint System Supplemental "AIR BAG"

The Supplemental Restraint System Supplemental "Air Bag", used along with seat belts, helps to reduce the risk or severity of injury to the driver in a frontal collision. The Supplemental Restraint System consists of a supplemental air bag module (located in the center of the steering wheel), sensors, a diagnosis (control) unit, warning lamp, wiring harness and spiral cable. Information necessary to service the system safely is included in the **BF section** of this Service Manual.

### WARNING:

- **To avoid rendering the SRS inoperative, which could lead to personal injury or death in the event of a severe frontal collision, all maintenance must be performed by an authorized NISSAN dealer.**
- **Improper maintenance, including incorrect removal and installation of the SRS, can lead to personal injury caused by unintentional activation of the system.**
- **All SRS electrical wiring harnesses and connectors are covered with yellow outer insulation. Do not use electrical test equipment on any circuit related to the SRS Supplemental "Air Bag".**

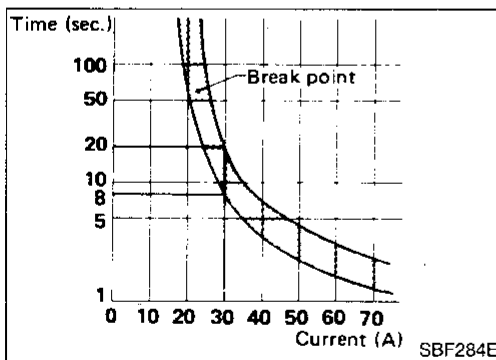

## Circuit Breaker Inspection

For example, when current is 30A, the circuit is broken within 8 to 20 seconds.

Circuit breakers are used in the following systems:

### Circuit Breaker 1

- Power door lock
- Power window
- Power sun roof
- Digital touch entry system



### Circuit Breaker 2

- Front power seat
- Automatic seat belt system

# GENERAL SERVICING

## Clip and Fastener

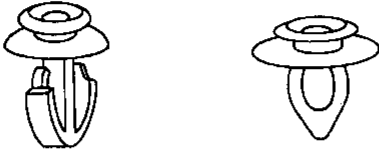
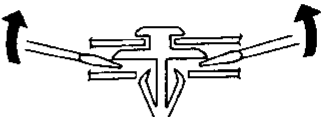

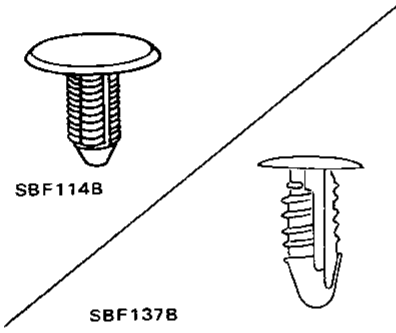
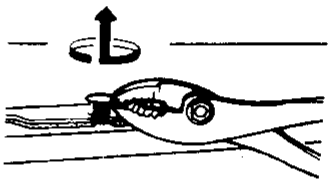



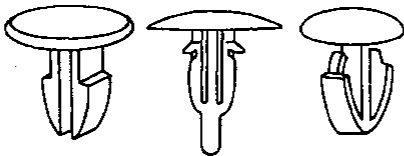
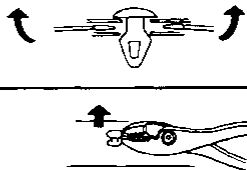

- Clips and fasteners in BF section correspond to the following numbers and symbols.
- Replace any clips and/or fasteners which are damaged during removal or installation.

Symbol No.	Shapes	Removal & Installation
 <p>C101</p>	 <p style="text-align: right; margin-right: 50px;">SBF256G</p>	<p><b>Removal:</b> Remove by bending up with flat-bladed screwdrivers.</p>  <p style="text-align: right;">SBF367B</p>
 <p>C102</p>	 <p style="text-align: center;">SBF114B</p> <p style="text-align: center;">SBF137B</p>	 <p><b>Removal:</b> Pull up by rotating.</p> <p style="text-align: right;">SBF115B</p>

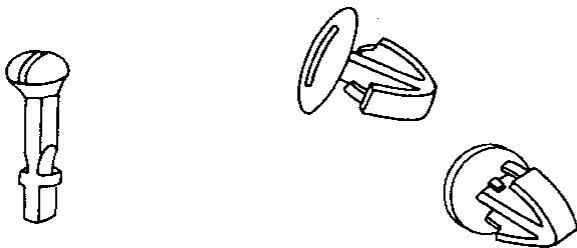
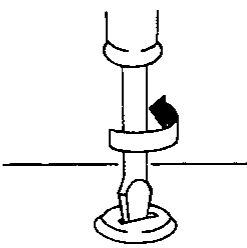
GI  
 MA  
 EM  
 LC  
 EF &  
 EC  
 FE  
 AT  
 FA  
 RA  
 BR  
 ST  
**BF**  
 HA  
 EL  
 IDX

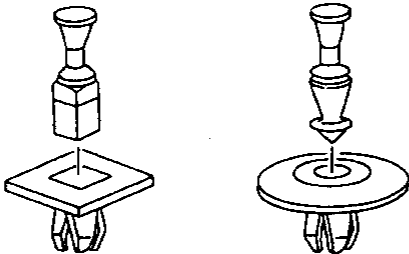
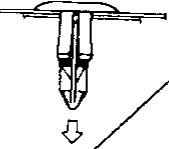
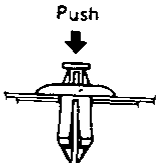
# GENERAL SERVICING

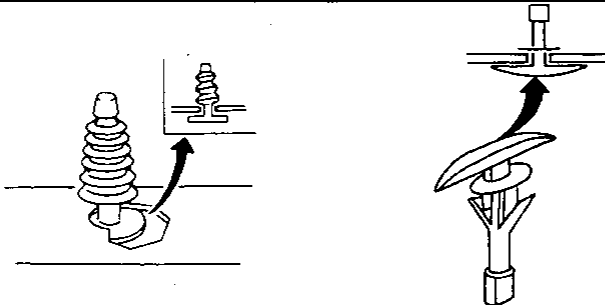
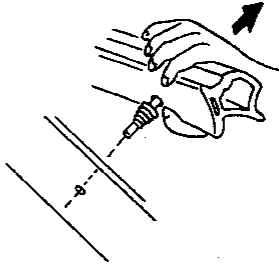
## Clip and Fastener (Cont'd)

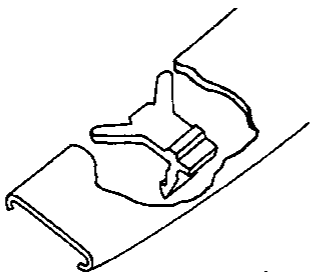
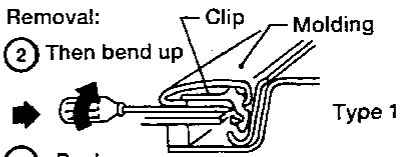
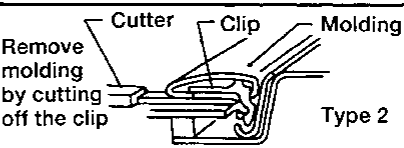
Symbol No.	Shapes	Removal & Installation
		<p>Removal: Remove with a flat-bladed screwdriver or pliers.</p> 
		
		<p>Push center pin to catching position. (Do not remove center pin by hitting it.)</p> <p>Push</p>  <p>Installation:</p> 
		
		<p>Removal:</p> <p>Clip Molding</p> <p>② Then bend up</p>  <p>Type 1</p> <p>① Push</p> <p>Cutter Clip Molding</p> <p>Remove molding by cutting off the clip</p>  <p>Type 2</p>

ABF161



## BODY END

---

### Body Front End

- When removing or installing hood or trunk lid, place a cloth or other padding on hood or trunk lid to avoid scratching vehicle body.
- Hood adjustment: Adjust at hinge portion.
- Hood lock adjustment: After adjusting, check hood lock control operation. Apply a coat of grease to hood lock engaging mechanism.
- Hood opener: Do not attempt to bend cable forcibly.

#### REMOVAL — Front bumper assembly

- If fascia retainer bolts and four bumper fascia clips are to be accessed from above headlamps require removal prior to removal of front bumper assembly.
- ① Remove left and right screws securing fender protector to bumper fascia.
- ② Remove the four clips (C102) securing bumper fascia to radiator core support.
- ③ Remove the three clips (C102) securing bumper fascia to bumper reinforcement.
- ④ Remove the four left and right screws securing bumper fascia to fender.
- ⑤ Remove the two left and right nuts securing bumper fascia to fender.
- ⑥ Remove the four left and right bolts securing fascia retainer to closing plate.
- ⑦ Remove the two left and right clips securing bumper fascia to fender bracket.
- ⑧ Remove bumper fascia.
- ⑨ Remove the eight left and right bolts securing bumper reinforcement to bumper shock absorber support.
- ⑩ Remove the six left and right bolts securing bumper shock absorber support to side member.



# BODY END

## Body Front End (Cont'd)

### Hood lock adjustment

- Adjust lock so that hood primary lock meshes at a position where hood is 1 to 1.5mm (0.039 to 0.059 in) lower than fender.
- After hood lock adjustment, adjust bumper rubber.
- When securing hood lock, ensure it does not tilt. Striker must be positioned at the center of hood primary lock.
- After adjustment, ensure that hood primary and secondary lock operate properly.

Hood lock secondary latch hooking length:

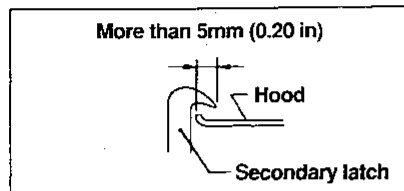

### Bumper rubber adjustment

- Adjust so that hood is aligned with fender. [Bumper rubber free height is approx. 13 mm (0.51 in)]

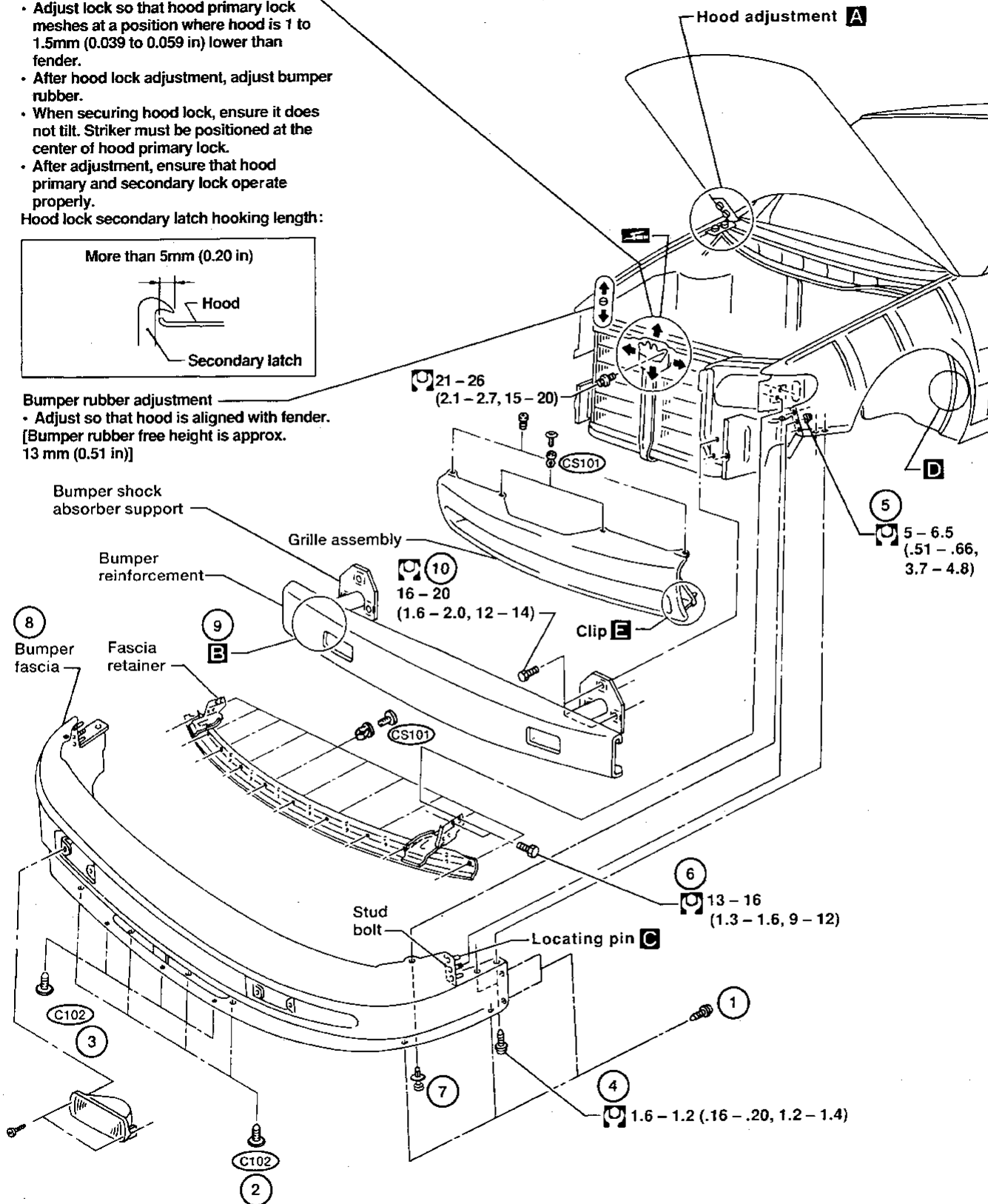

: N·m (kg-m, ft-lb)

: Should be lubricated with grease

GI  
MA  
EM  
LC  
EF & EC  
FE  
AT  
FA  
RA  
BR  
ST  
BF  
HA  
EL  
IDX

# BODY END

## Body Front End (Cont'd)

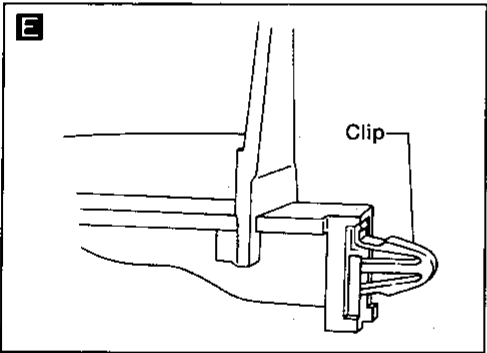
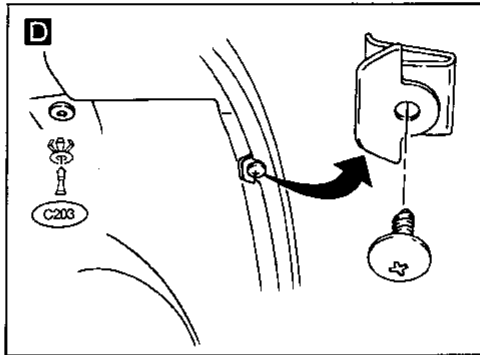
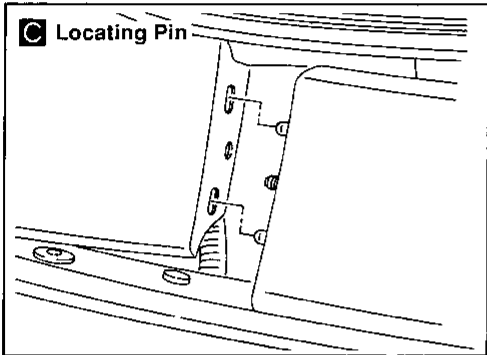
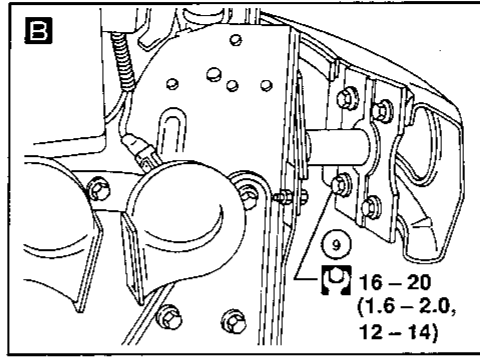
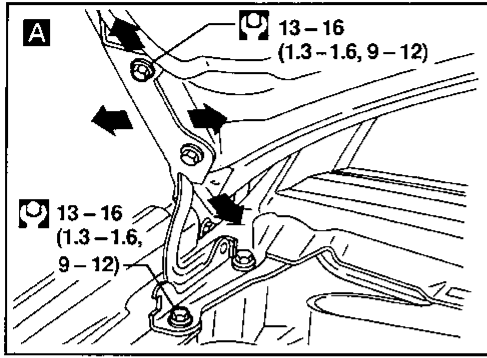

$\square$  : N·m (kg·m, ft·lb)

## BODY END

### Body Front End (Cont'd)

#### BUMPER SHOCK ABSORBER INSPECTION — Front

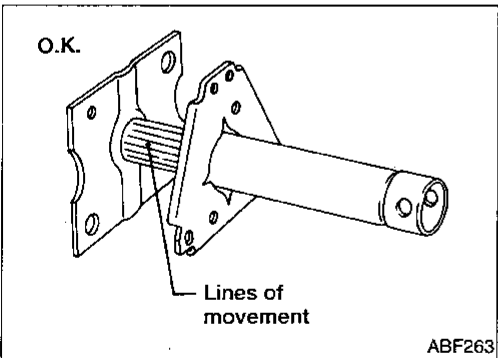
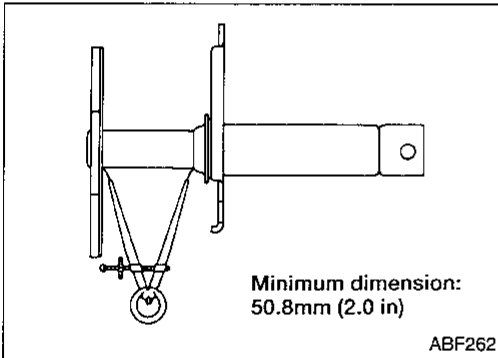
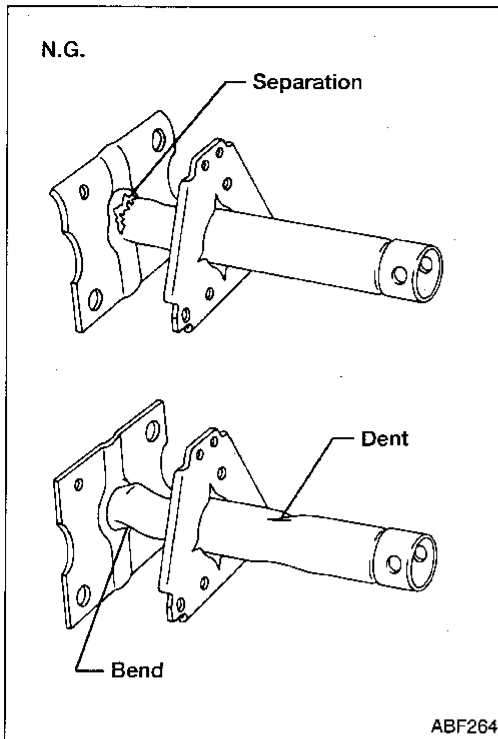

1. Inspect the absorber unit for any deformation. It is acceptable to repair a bent mounting bracket using a cold straightening method. If damage is apparent, such as a separation, dent, or bend, replace the absorber unit.

GI

MA

EM

LC

EF &

EC

FE

AT

FA

2. Measure the distance of the absorber unit shaft between the mounting brackets.

**Minimum acceptable dimension:**

**50.8 mm (2.0 in)**

- If the dimension is less than acceptable, replace the absorber unit.

RA

BR

ST

3. Lines of movement on the absorber unit shaft are acceptable only if the dimension of the shaft meets the requirements described above.

BF

HA

4. When installing, tighten the mounting bracket bolts to specification.

**Body front end:**

13 - 16 N·m (1.3 - 1.6 kg·m, 9 - 2 ft·lb)

**Body rear end:**

31 - 42 N·m (3.2 - 4.3 kg·m, 23 - 31 ft·lb)

EL

IDX

### Body Rear End and Opener

- Back door adjustment: Adjust at hinge for proper back door fit.
- Back door lock system adjustment: Adjust lock & striker so that they are in the center. After adjustment, check back door lock operation.
- Before removing bumper, remove side marker lamps.
- Opener cable: Do not attempt to bend cable using excessive force.
- After installation, make sure that back door and fuel filler lid open smoothly.

#### WARNING:

- **Be careful not to scratch back door stay and/or back door hatch stay when installing back door and/or back door hatch. A scratched stay may cause gas leakage.**
- **The contents of the back door stay and back door hatch stay are under pressure. Do not take apart, puncture, apply heat or allow fire near them.**

#### REMOVAL — Rear bumper assembly

- ① Remove seven clips (CS101) securing bumper fascia to body.
- ② Remove four screws and seven clips (CS101) securing sight shield to bumper fascia.
- ③ Remove six nuts securing bumper fascia to body.
- ④ Remove bumper fascia.
- ⑤ Remove side markers.
- ⑥ Remove eight nuts securing bumper reinforcement to shock absorbers.
- ⑦ Remove bumper reinforcement.
- ⑧ Remove six nuts and shock absorbers.

#### BUMPER SHOCK ABSORBER INSPECTION — Rear

The rear bumper shock absorber inspection is the same as the front bumper shock absorber inspection. For inspection of the front bumper shock absorber, refer to "BUMPER SHOCK ABSORBER INSPECTION" in "Body Front End".



# BODY END

## Body Rear End and Opener (Cont'd)

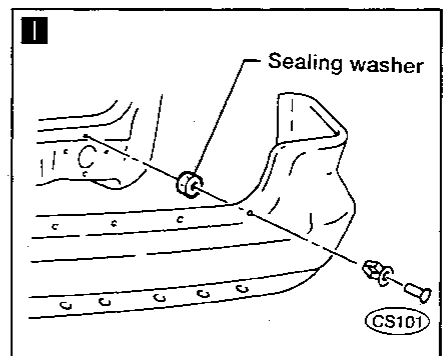
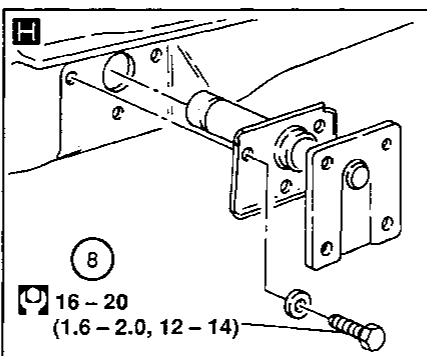
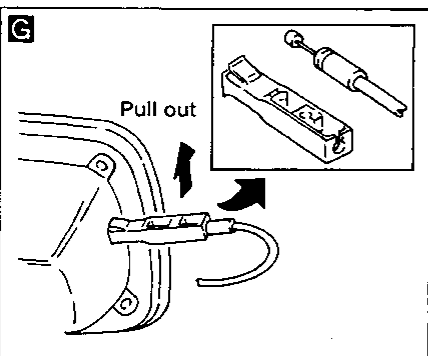
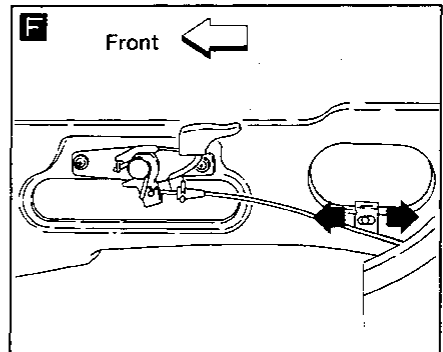
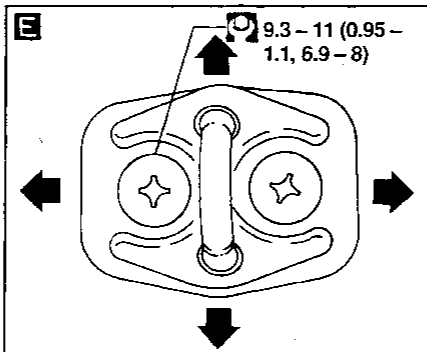
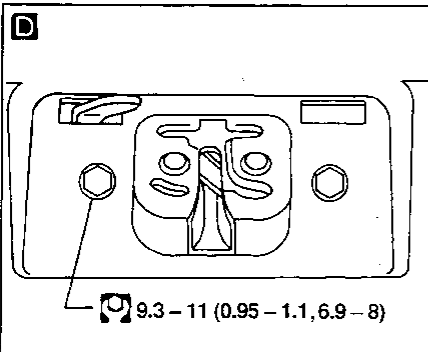
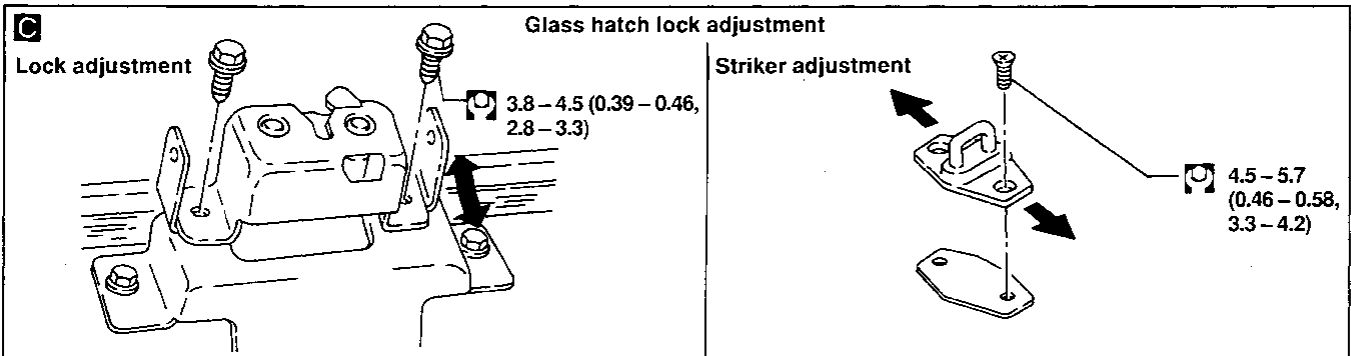
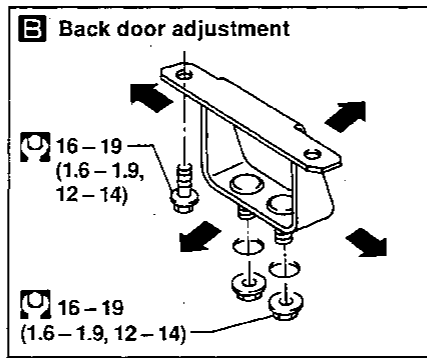
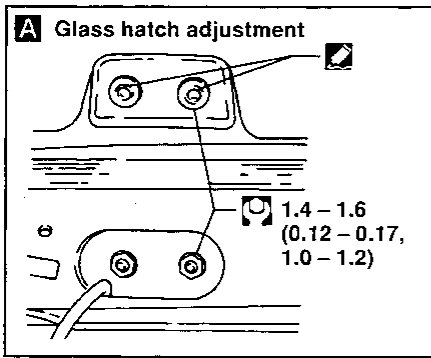

: N·m (kg-m, ft-lb)

ABF251

# DOOR

## Front Door

- For removal of door trim, refer to "Interior" in "INTERIOR AND EXTERIOR".
- After adjusting door or door lock, check door lock operation.

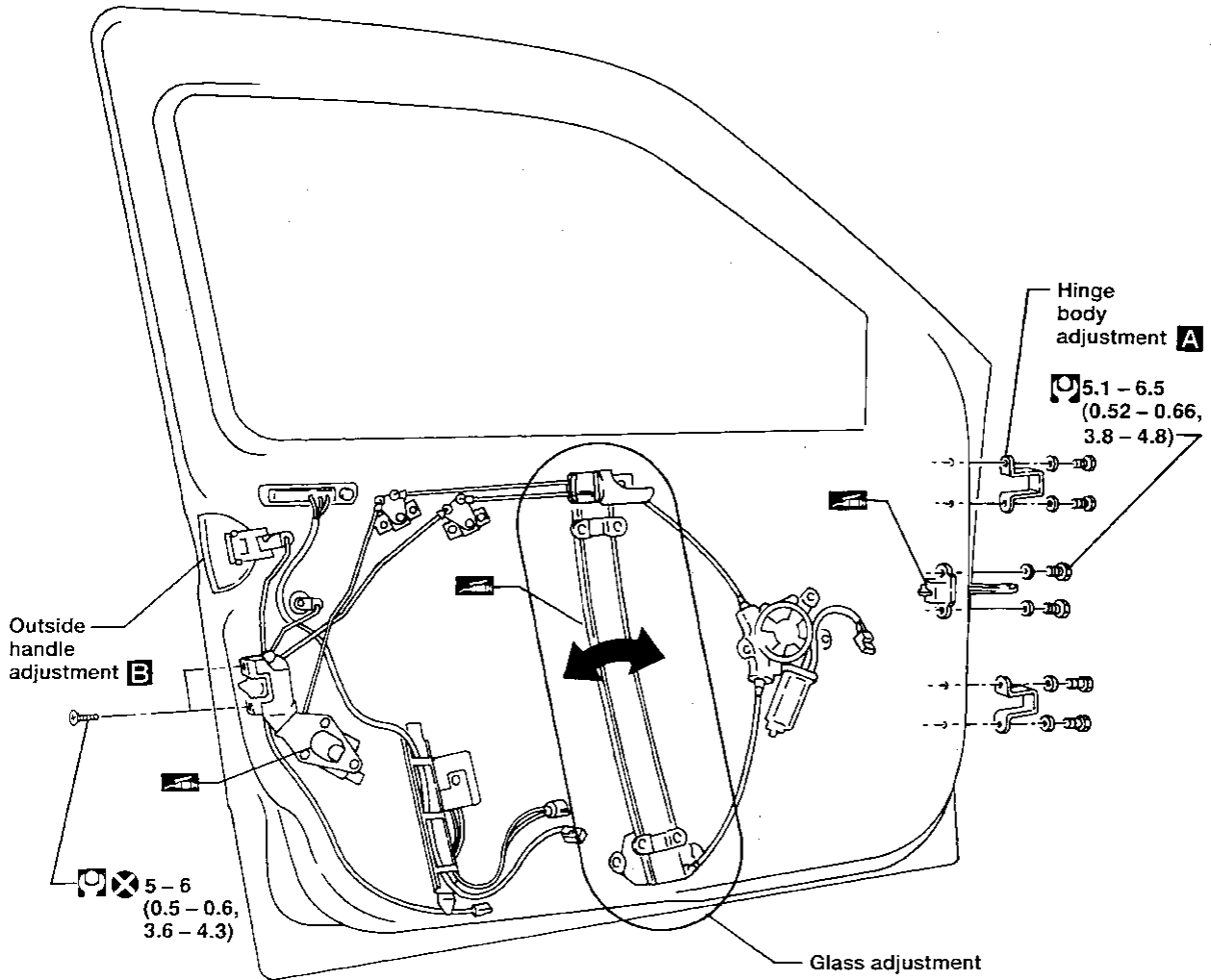

Hinge body adjustment

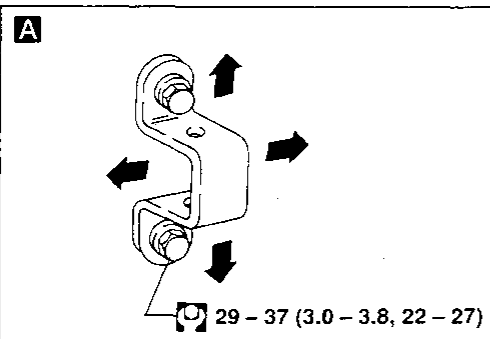

Outside handle adjustment

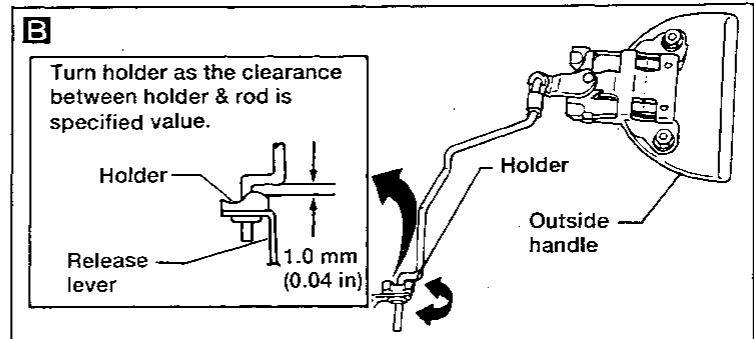

Striker adjustment

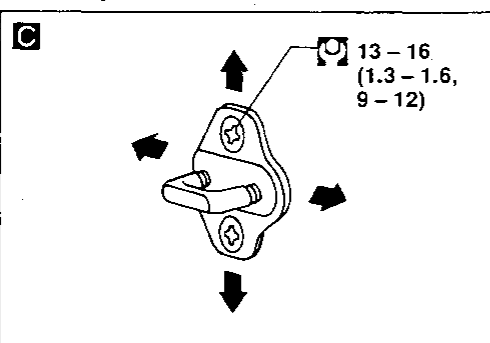

⊗ : N·m (kg·m, ft·lb)

ABF266

⊗ : Always replace after every disassembly

BF-13

GI  
HA  
EM  
LC  
EF & EC  
FE  
AT  
FA  
RA  
BR  
ST  
BF

HA  
EL  
IDX

# DOOR

## Sliding Door

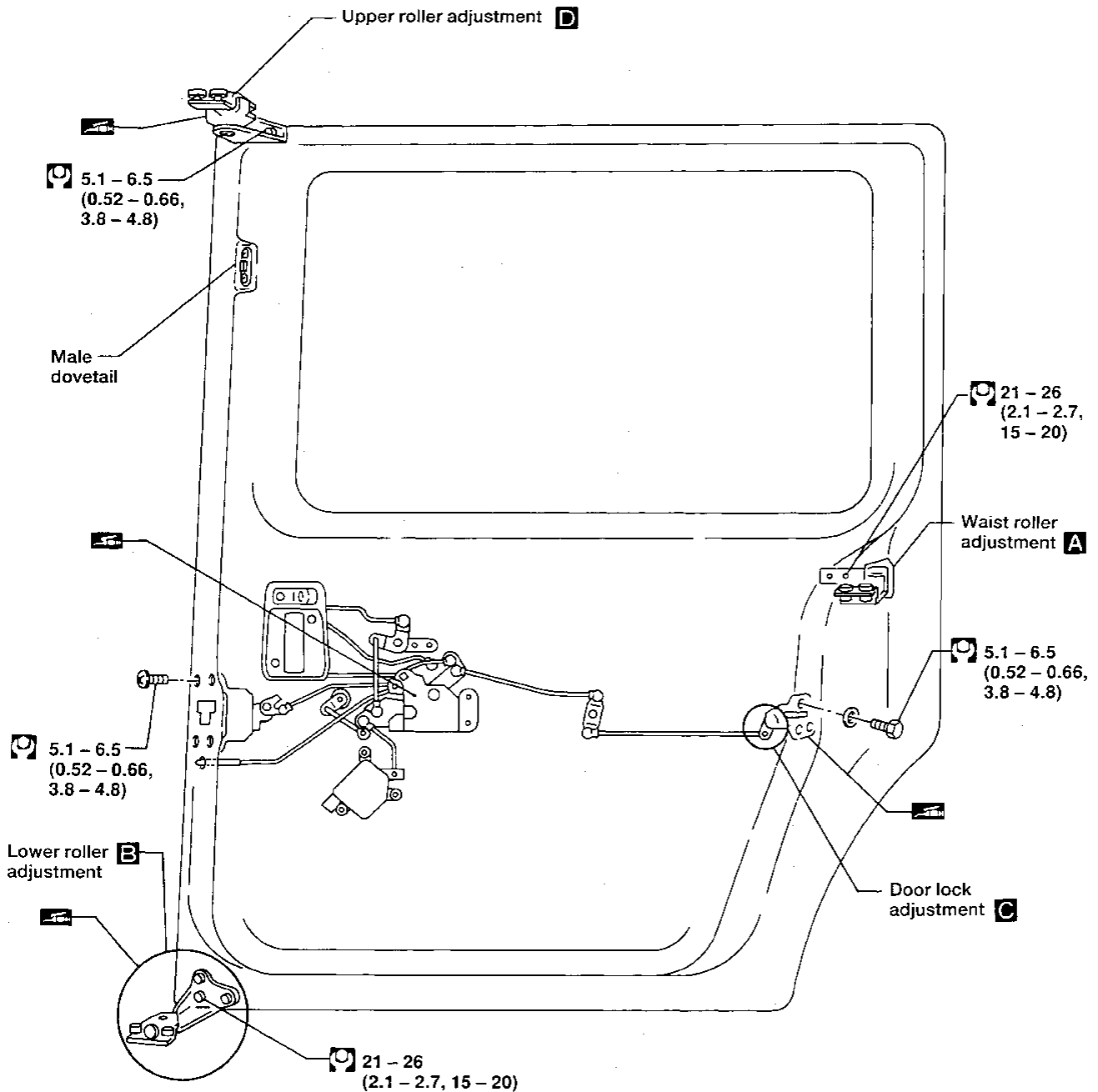

Dovetail adjustment

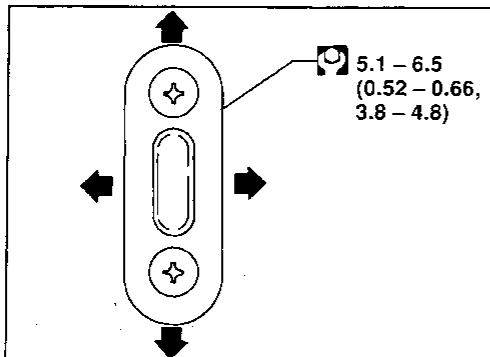

Striker adjustment

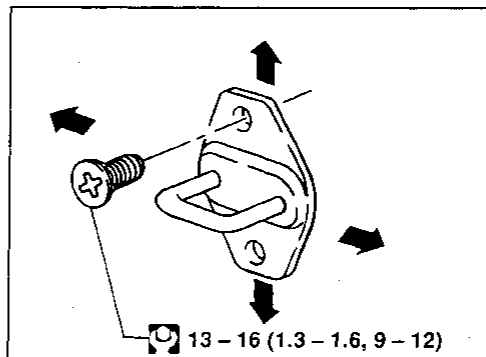

: N·m (kg-m, ft-lb)

ABF004-1



# DOOR

## Sliding Door (Cont'd)

CI  
 MA  
 EM  
 LC  
 EF & EC  
 FE  
 AT  
 FA  
 RA  
 BR  
 ST  
**BF**  
 HA  
 EL  
 DX

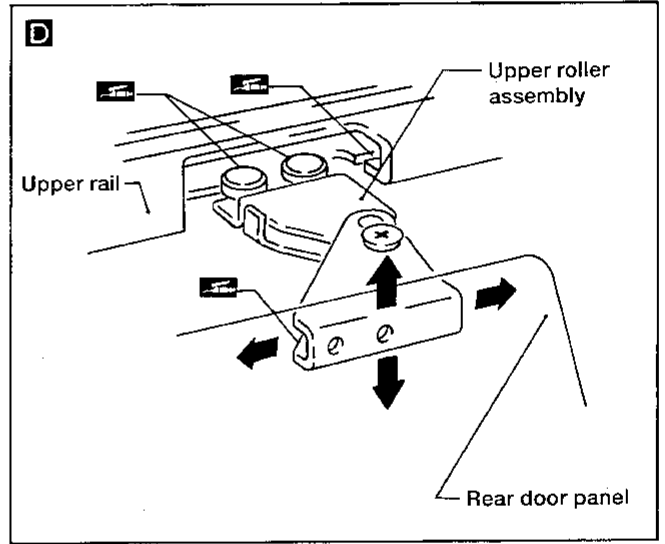
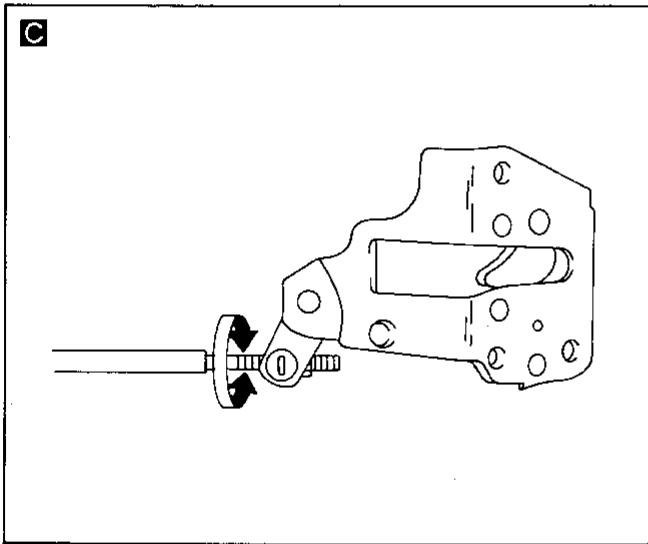
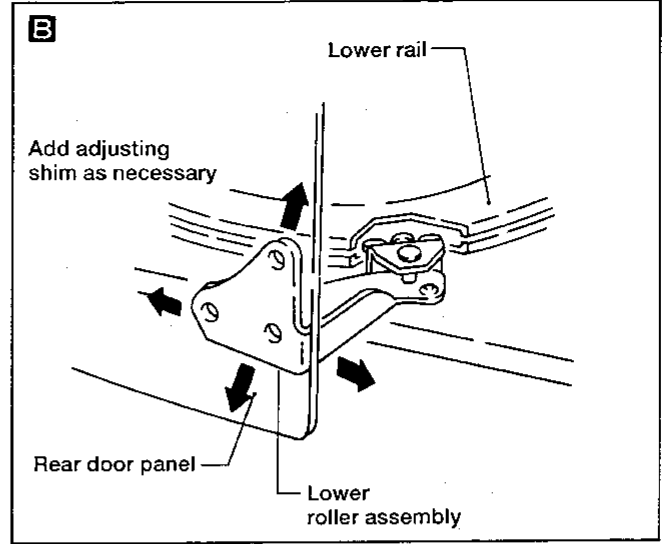
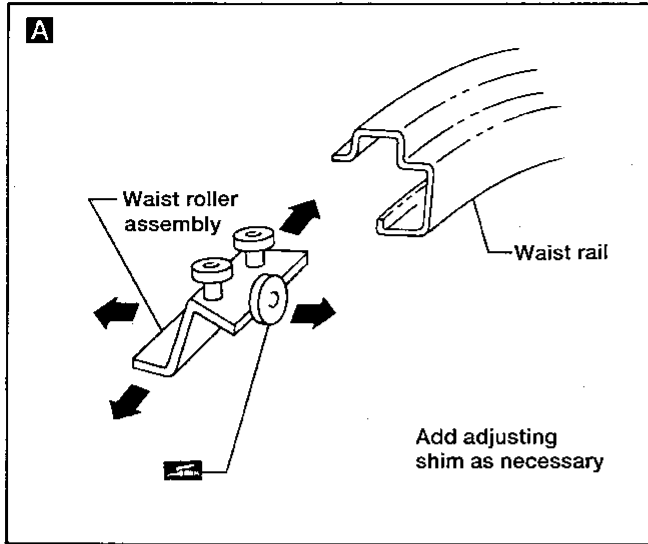

: N•m (kg-m, ft-lb)

ABF244

# POWER DOOR LOCK

## System Description

If equipped with digital touch entry system, refer to EL section (“System Description”, “DIGITAL TOUCH ENTRY SYSTEM”).

### POWER DOOR LOCKS

The door lock and unlock switches (LH and RH) activate the power door lock actuators. The door key and lock knob switch will activate the lock feature of the power door lock system.

Power is supplied at all times:

- to the door lock timer terminal ④
- through circuit breaker-1.

Ground is supplied:

- to the door lock timer terminal ⑧
- to the lock and unlock switch (LH and RH) terminal ③, and
- to the front door actuator LH terminal ④ for the lock knob switch
- through body grounds M5 and M75.

### UNLOCK

When either door lock and unlock switch is pressed to the UNLOCK position, ground is supplied:

- to the door lock timer terminal ③
- from the lock and unlock switch terminal ②.

When the door lock timer receives this ground input:

- the door lock timer terminal ② supplies power to each door actuator terminal ②, and
- the door lock timer terminal ⑩ supplies ground to each door actuator terminal ①.

With power and ground supplied, all the door lock actuators move to the UNLOCK position.

### LOCK

When either door lock and unlock switch is pressed to the LOCK position, ground is supplied:

- to the door lock timer terminal ⑤
- from the lock and unlock switch terminal ①.

When the door key or lock knob switch is moved to the LOCK position, ground is removed:

- from the door lock timer terminal ⑥
- through the front door actuator LH terminal ③.

When the door lock timer receives either of these inputs:

- the door lock timer terminal ⑩ supplies power to each door actuator terminal ①, and
- the door lock timer terminal ② supplies ground to each door actuator terminal ②.

With power and ground supplied, all the door lock actuators move to the LOCK position.

### LOCK - Sliding Door Delay

When any door lock switch is pressed to the LOCK position, with the sliding door open, all the door lock actuators, except the sliding door lock actuator, move to the LOCK position.

When the sliding door is closed, the time control module sends a signal to the door lock timer terminal ①. The door lock timer then moves the sliding door actuator to the LOCK position.

# POWER DOOR LOCK

---

## NOTE

GI

MA

EM

LC

EF &  
EC

FE

AT

FA

RA

BR

ST

**BF**

HA

EL

IDX

# POWER DOOR LOCK

## Wiring Diagram -D/LOCK-

**BF-D/LOCK-01**

**POWER AT ALL TIMES**

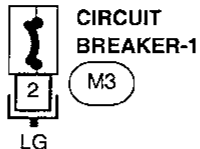

N : MODELS WITHOUT DIGITAL TOUCH ENTRY  
 DT : MODELS WITH DIGITAL TOUCH ENTRY

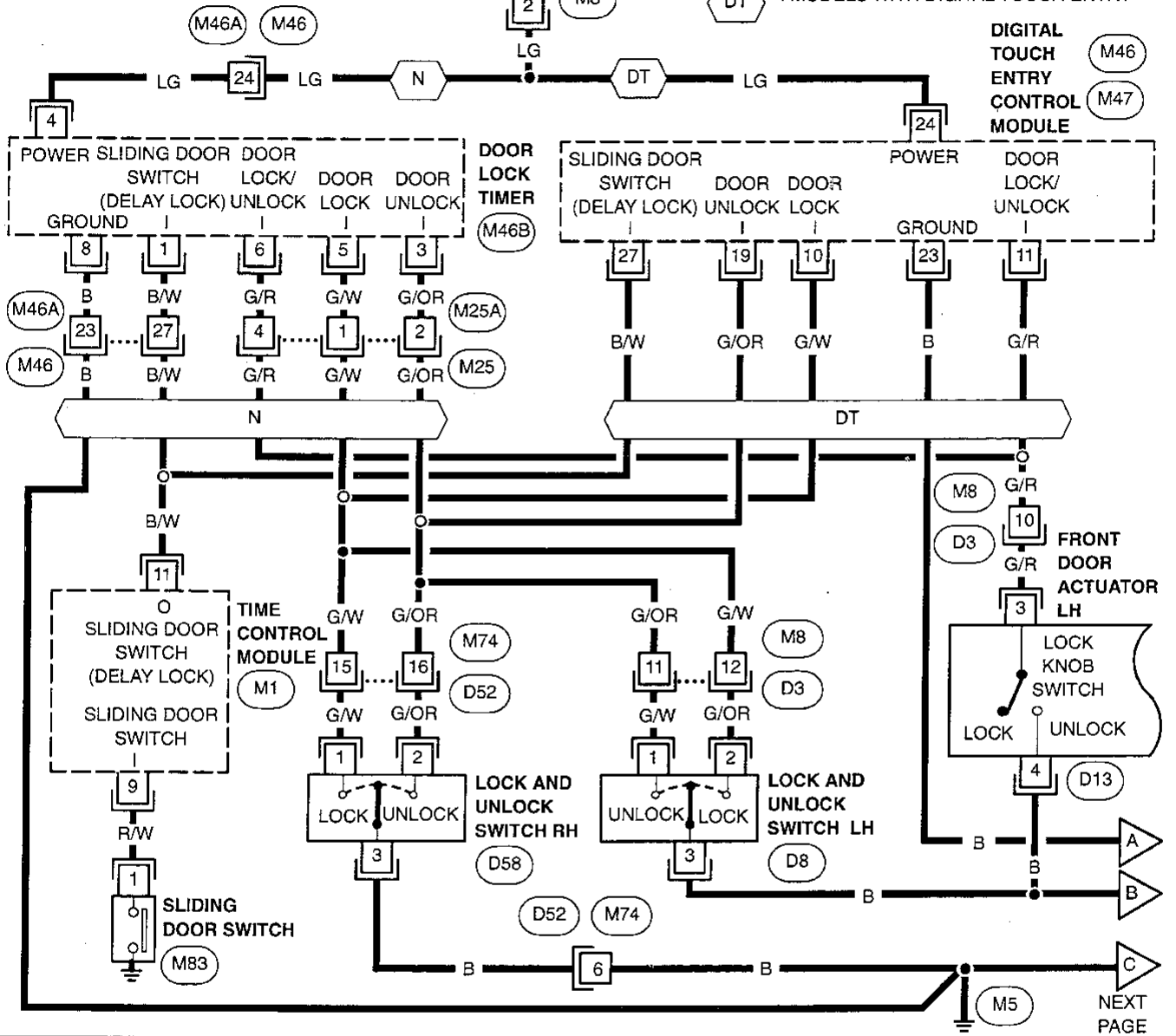

NEXT PAGE

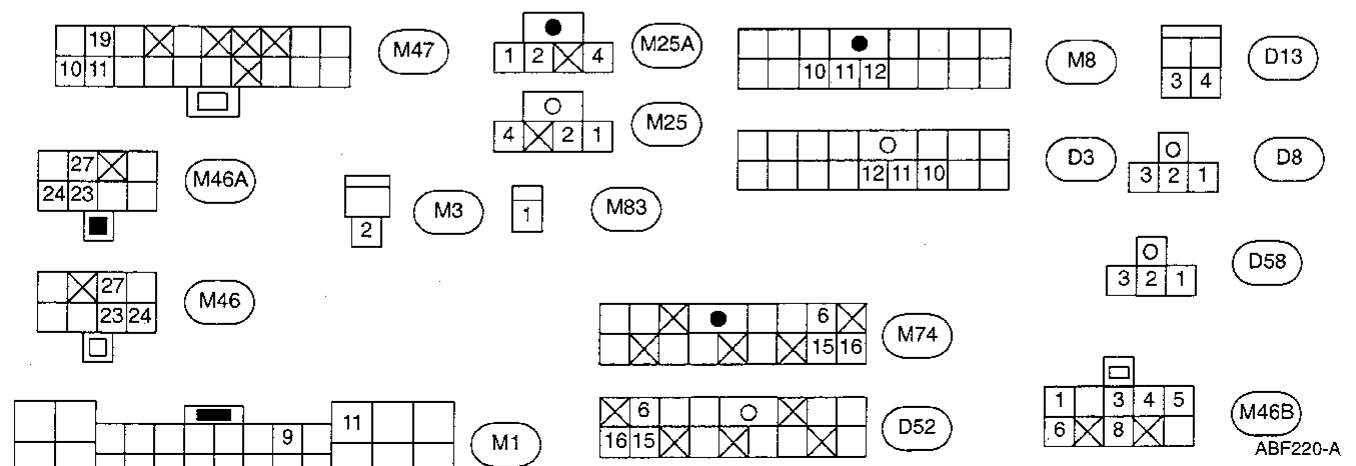

**BF-18**

# POWER DOOR LOCK

## Wiring Diagram -D/LOCK- (Cont'd)

### BF-D/LOCK-02

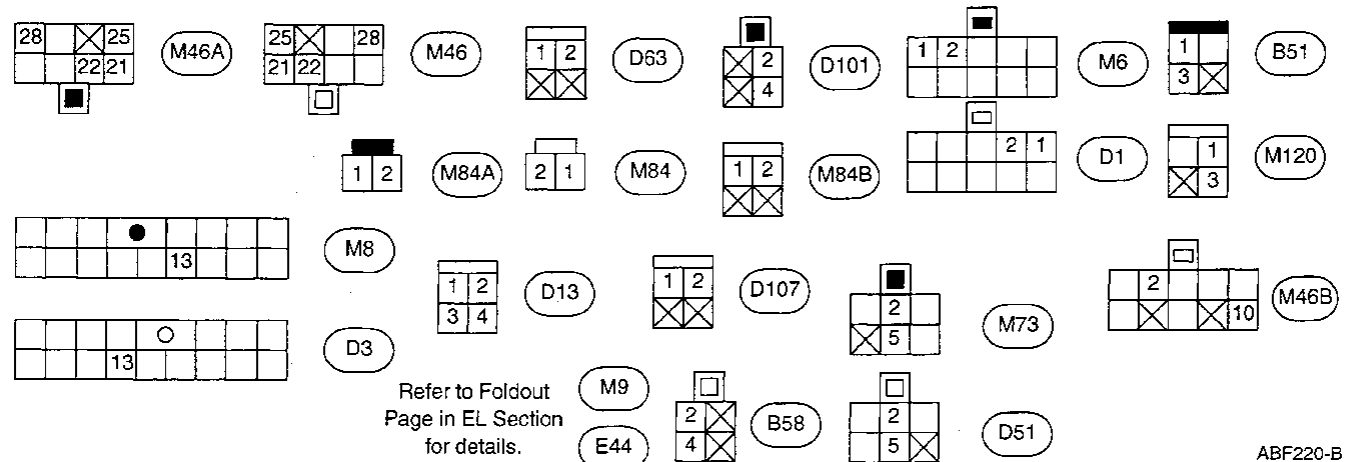
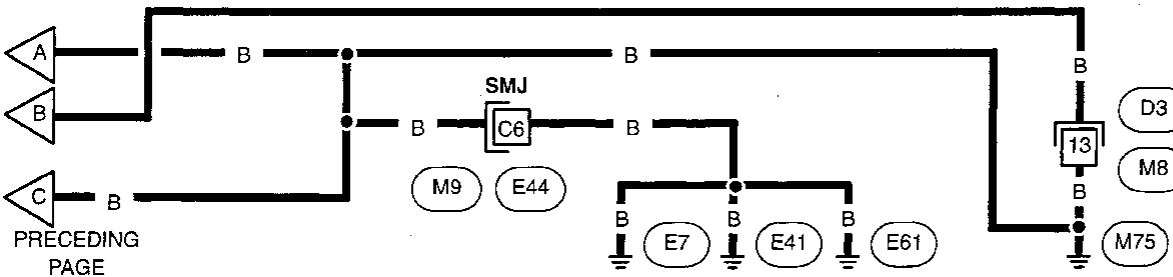
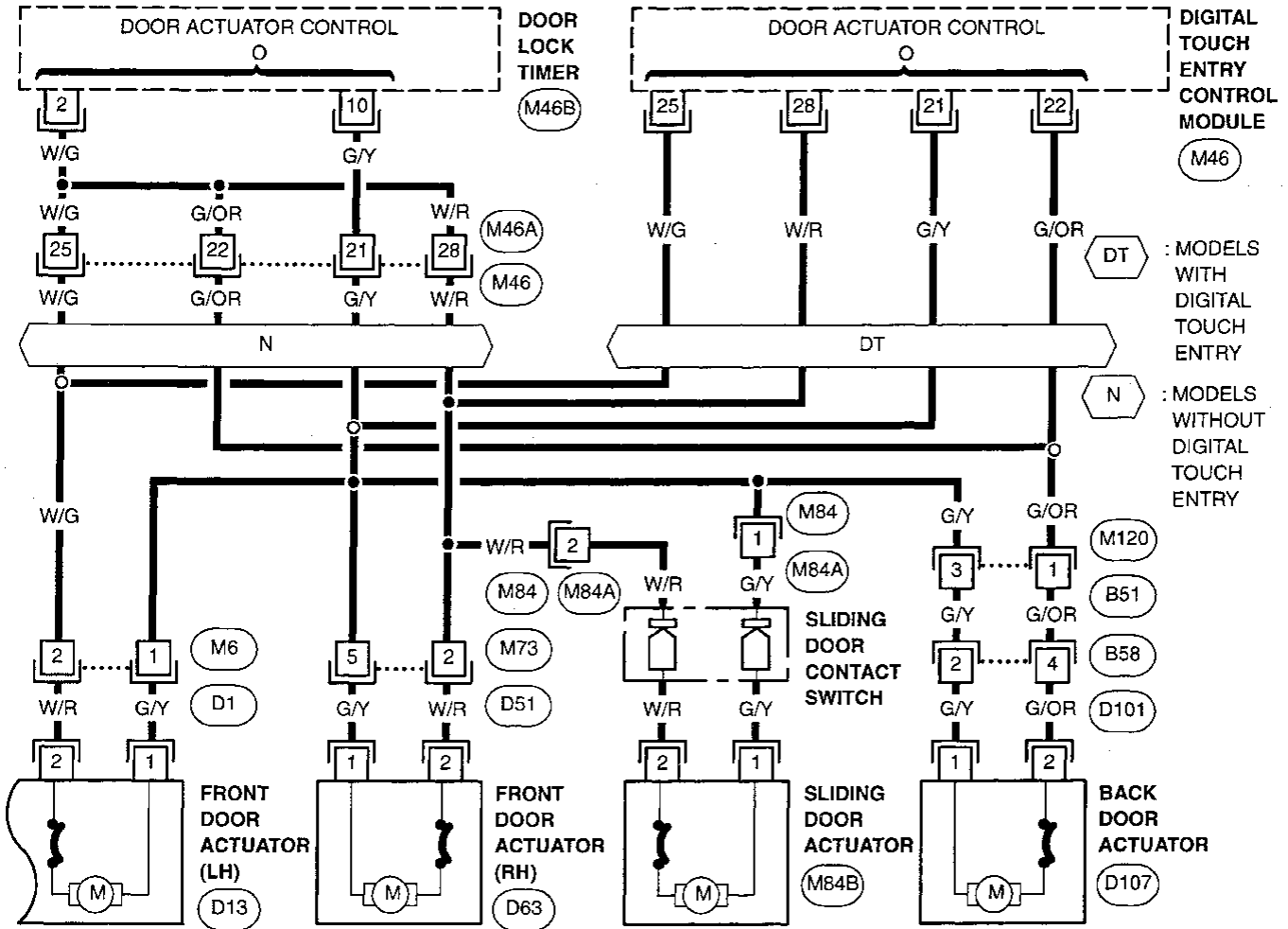

Refer to Foldout Page in EL Section for details.

ABF220-B

# POWER DOOR LOCK

## Trouble Diagnoses

### SLIDING DOOR LOCK DELAY OPERATION

If the sliding door is open when lock signal is given by lock knob switch or armrest switches, all doors, except the sliding door, are closed. The sliding door locks when it is closed. Any unlock signals prior to closing the sliding door cancel the sliding door lock delay operation.

### DOOR LOCK TIMER INSPECTION

- Carry out the following inspections:

(1) Check power source and ground.

(2) Check input signals.

If the input signal is NG, check harness and go to BF-21.

(3) Check output signals.

If the input signal is OK, and the output signal is NG, replace the door lock timer.

If the input signal and output signal are OK, check harness and door lock actuator in ELECTRICAL COMPONENTS INSPECTION. Refer to BF-21.

Terminal number		Terminal connections		Operations					
				Lock knob switch		Lock & unlock switch			
		Unlock→Lock	Lock→Unlock	N→Lock	N→Unlock	N→Lock	*		
Ⓣ	Ⓝ	Sliding door is closed.				Open	Open→Closed		
24	4	Power source	12V						
23	8	Ground	Ground						
27	1	Input signals	Sliding door switch	OFF			ON	ON→OFF	
19	3		Lock & unlock switch (Unlock)	—	—	—	OFF→ON	—	
10	5		Lock & unlock switch (Lock)	—	—	OFF→ON	—	OFF→ON	
11	6		Lock knob switch	ON→OFF	OFF→ON	—	—	—	
22 25 28	2	Output signals	Door lock actuator (Unlock power source)	0V	—	0V	12V (Approx. 1.0 sec.) →0V	0V	0V
21	10		Door lock actuator (Lock power source)	12V (Approx. 1.0 sec.) →0V	—	12V (Approx. 1.0 sec.) →0V	0V	12V (Approx. 1.0 sec.) →0V	12V (Approx. 1.0 sec.) →0V

- The voltages are approximate values.

- Continuity with ground should exist when ON, should not exist when OFF.

Ⓣ: Equipped with digital touch entry system.

Ⓝ: Not equipped with digital touch entry system.

\*: Open sliding door, push lock switch, then close sliding door.

# POWER DOOR LOCK

## Trouble Diagnoses (Cont'd)

### ELECTRICAL COMPONENTS INSPECTION

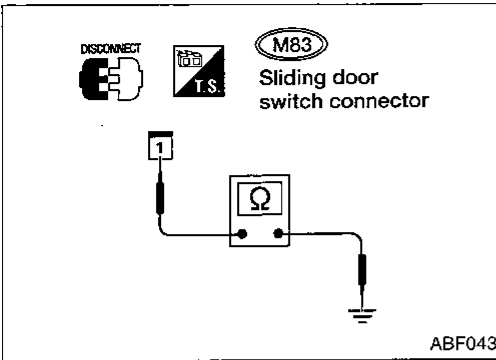

#### Sliding door switch

Terminals	Condition	Continuity
① - Ground	Door is closed.	No
	Door is open.	Yes

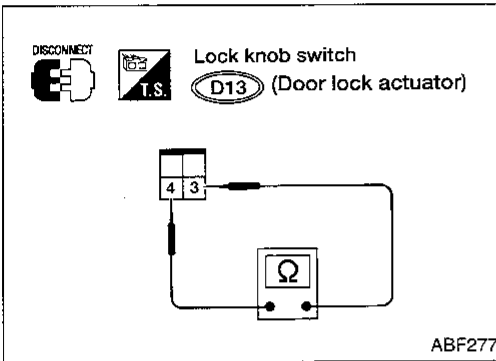

#### Lock knob switch (built into driver side door lock actuator)

Terminals	Condition	Continuity
④ - ③	Lock	No
	Unlock	Yes

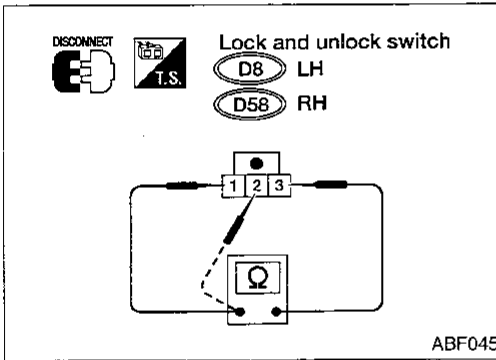

#### Lock and unlock switch

Terminals	Operation	Continuity
① - ③	Lock	Yes
	Neutral and unlock	No
② - ③	Unlock	Yes
	Neutral and unlock	no

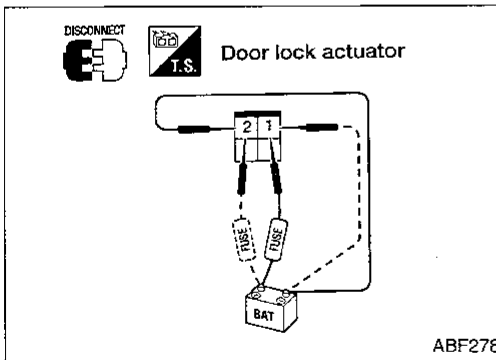

#### Door lock actuator

Terminals		Operation
⊕	⊖	
①	②	Lock
②	①	Unlock

CI  
MA  
EM  
LC  
EF & EC  
FE  
AT  
FA  
RA  
BR  
ST  
BF  
HA  
EL  
IDX

# POWER WINDOW

## System Description

The power window main switch, located in the driver door, contains individual switches for the driver side and passenger side power windows. The driver can also control the operation of the rear power windows through the rear window opener switch, located in the overhead switch panel. The power window sub switch, located in the passenger side door, controls the operation of the passenger side power window. The window lock switch disables the operation of the passenger side power window by interrupting the ground path of the passenger side power window regulator.

Power is supplied at all times:

- through 30A fusible link (No. 13, located in the fusible link box-1)
- to circuit breaker-1 terminal ①
- through circuit breaker-1 terminal ②
- to power window relay terminal ⑤.

With the ignition switch in the ON or START position, power is supplied:

- through 10A fuse (Letter 1, located in the fuse block)
- to power window relay terminal ②, and
- to the power window amplifier terminal ⑤1.

Ground is supplied:

- to power window relay terminal ①
- to power window main switch terminal ④
- to power window amplifier terminal ⑤2
- through body grounds (M5) and (M75).

With power and ground supplied, the power window relay is energized and power is supplied:

- to power window main switch terminal ⑤
- to power window sub switch terminal ①
- to power window amplifier terminal ⑤3, and
- to rear window opener switch terminal ①.

## DRIVER SIDE WINDOW OPERATION

When the power window main switch is pressed in the DOWN position, ground is supplied:

- through the power window main switch terminal ②
- to the power window amplifier terminal ⑤6.

When a ground signal is sent to the power window amplifier terminal ⑤6, the power window amplifier supplies power:

- through the power window amplifier terminal ⑤7
- to the driver side power window regulator terminal ②.

Ground is supplied:

- to the driver side power window regulator terminal ①
- through the power window amplifier terminal ⑤8.

With power and ground supplied, the driver side power window goes down.

When the power window main switch is pressed in the UP position, power is supplied:

- through the power window main switch terminal ③
- to the power window amplifier terminal ⑤5.

When a power signal is sent to the power window amplifier terminal ⑤5, the power window amplifier supplies power:

- through the power window amplifier terminal ⑤8
- to the driver side power window regulator terminal ①.

Ground is supplied:

- to the driver side power window regulator terminal ②
- through the power window amplifier terminal ⑤7.

With power and ground supplied, the driver side power window goes up.

## PASSENGER SIDE WINDOW OPERATION

When the power window main switch is pressed in the DOWN (UP) position, power is supplied:

- through the power window main switch terminal ⑥ (⑦)
- to the power window sub switch terminal ③ (④)
- through the power window sub switch terminal ② (⑤)
- to the passenger side power window regulator terminal ② (①).



# POWER WINDOW

## System Description (Cont'd)

If the window lock switch, located in the power window main switch, is in the UNLOCK position, ground is supplied:

- through the power window main switch terminal ⑦ (⑥)
- to the power window sub switch terminal ④ (③)
- through the power window sub switch terminal ⑤ (②)
- to the passenger side power window regulator terminal ① (②).

With power and ground supplied, the passenger side power window goes down (up).

When the power window sub switch is pressed in the DOWN (UP) position, power is supplied:

- through the power window sub switch terminal ② (⑤)
- to the passenger side power window regulator terminal ② (①).

If the window lock switch, located in the power window main switch, is in the UNLOCK position, ground is supplied:

- through the power window main switch terminal ⑦ (⑥)
- to the power window sub switch terminal ④ (③)
- through the power window sub switch terminal ⑤ (②)
- to the passenger side power window regulator terminal ① (②).

With power and ground supplied, the passenger side power window goes down (up).

### REAR DRIVER SIDE WINDOW OPERATION

When the rear window opener switch is placed in the OPEN (CLOSE) position, power is supplied:

- through the rear window opener switch terminal ④ (⑤)
- to the rear driver side window opener regulator terminal ① (②).

Ground is supplied:

- to the rear driver side window opener regulator terminal ② (①)
- through the rear window opener switch terminal ⑤ (④).

With power and ground supplied, the rear driver side window opens (closes).

### REAR PASSENGER SIDE WINDOW OPERATION

When the rear window opener switch is placed in the OPEN (CLOSE) position, power is supplied:

- through the rear window opener switch terminal ② (③)
- to the rear passenger side window opener regulator terminal ① (②).

Ground is supplied:

- to the rear passenger side window opener regulator terminal ② (①)
- through the rear window opener switch terminal ③ (②).

With power and ground supplied, the rear passenger side window opens (closes).

### AUTO DOWN FEATURE

The power window AUTO feature enables the driver to lower the driver side window without holding the window switch in the DOWN position. When the AUTO switch, in the power window main switch, is pressed and released, the driver side window will travel to the fully open position. The AUTO feature only operates on the driver side window downward movement.

### LOCK FEATURE

The lock feature is designed to disable the operation of the passenger side power window. When the lock switch, in the power window main switch, is pressed to the LOCK position, the ground path for the passenger side power window regulator is interrupted and the passenger side power window becomes inoperative.

GI

MA

EM

LC

EF &  
EC

FE

AT

FA

RA

BR

ST

BF

HA

EL

IDX

# POWER WINDOW

## Wiring Diagram -WINDOW- BF-WINDOW-01

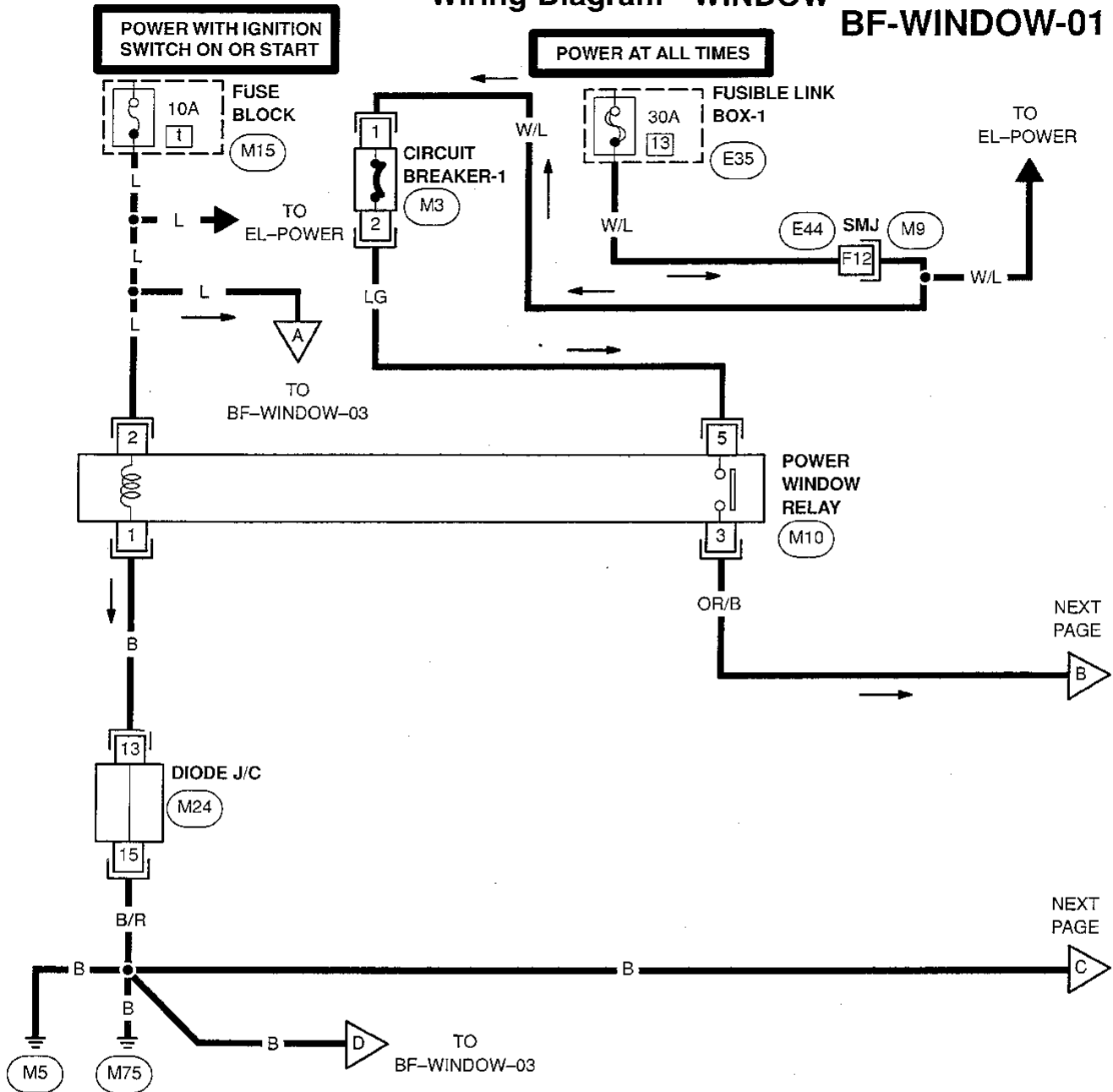

Refer to POWER SUPPLY ROUTING in EL Section (M15)

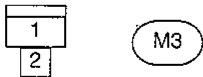

Refer to POWER SUPPLY ROUTING in EL Section (E35)

Refer to Foldout Page in EL Section for details. (M9, E44)

Refer to Foldout Page in EL Section for details. (M24)

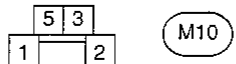

# POWER WINDOW

## Wiring Diagram -WINDOW- (Cont'd)

### BF-WINDOW-02

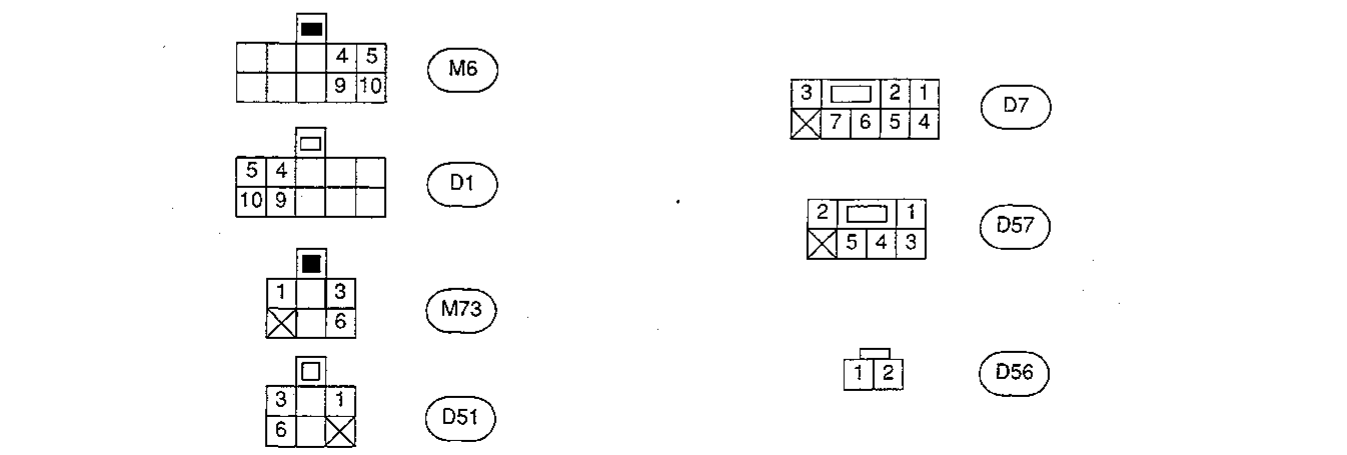
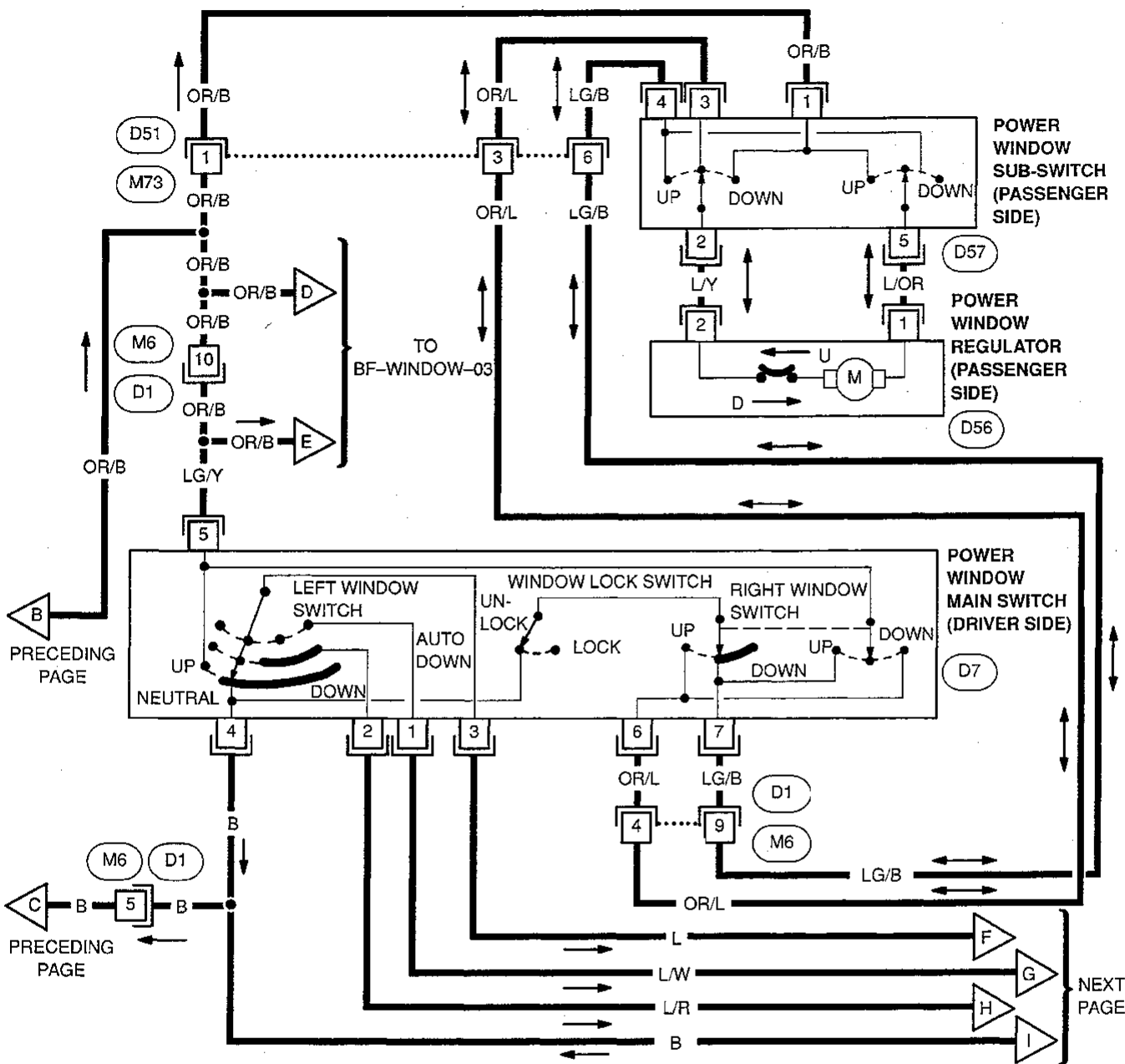

CI  
MA  
EM  
LC  
EF & EC  
FE  
AT  
FA  
RA  
BR  
ST  
BF  
HA  
EL  
IDX

# POWER WINDOW

## Wiring Diagram -WINDOW- (Cont'd)

### BF-WINDOW-03

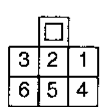
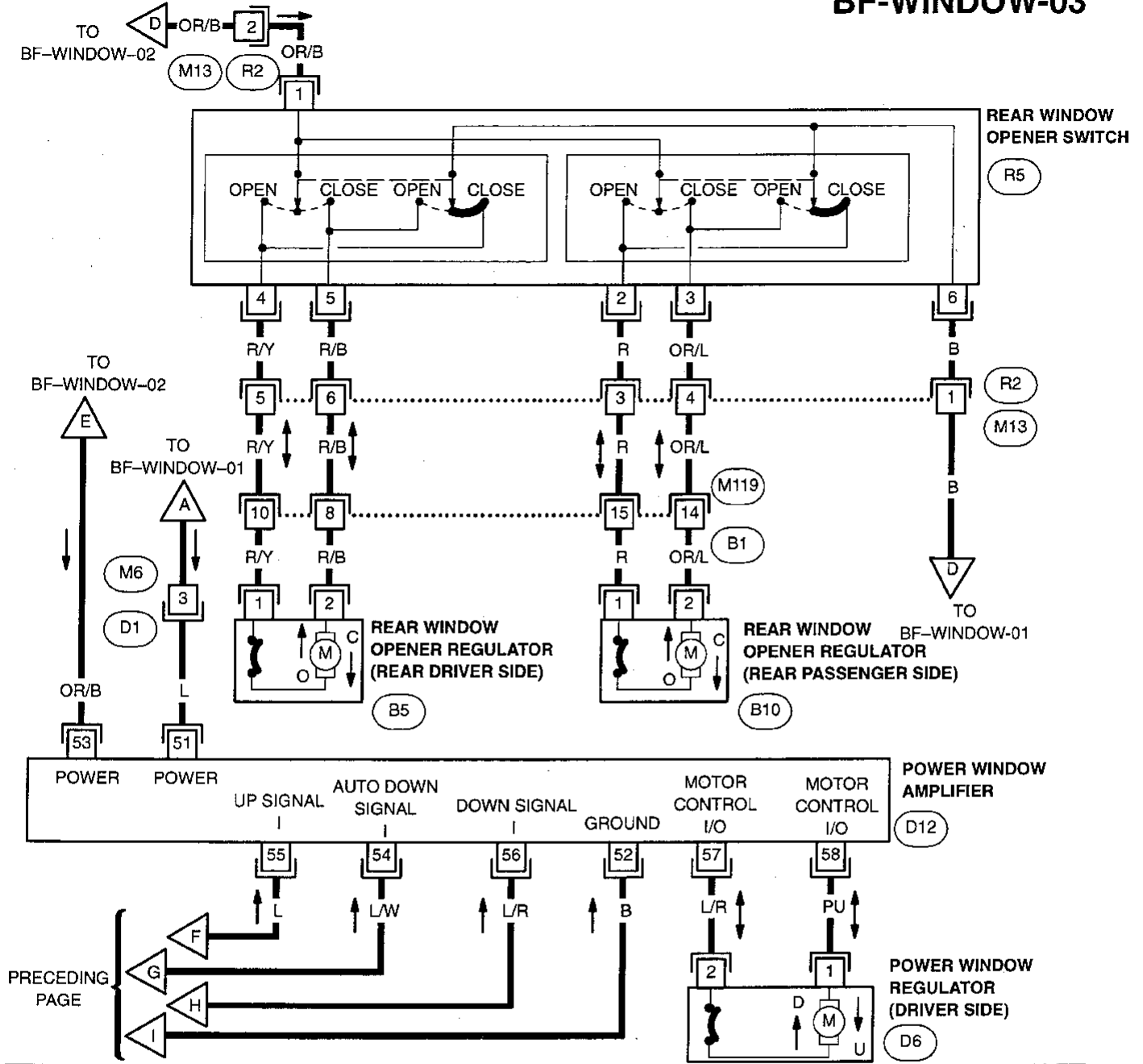

R5

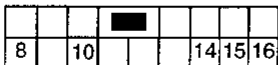

B1

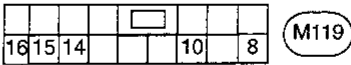

M119



B5

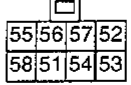

D12

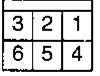

R2



B10



D6



M13

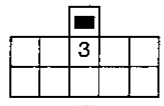

M6

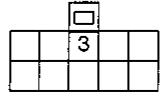

D1

# POWER WINDOW

## Trouble Diagnoses

### POWER WINDOW AMP. INSPECTION

Carry out the inspections below.

- (1) Power source and ground: Battery positive voltage should exist between terminals ⑤③ and ⑤② (IGN "ON" or "ST").
- (2) Check input signals.
- (3) Output signals: Battery positive voltage shown in the chart should exist.

Terminal connections		Operations (driver's side power window SW)					
		Manual operation			One-touch (Auto) operation		
		N	UP	Down	N	Down → N	
53	Power source (IGN)	12V	12V	12V	12V	12V	
52	Ground	Ground	Ground	Ground	Ground	Ground	
51	From ignition SW (ON or ST)	12V	12V	12V	12V	12V	
54	Input signal	To FR driver's power window SW (AUTO) ①	OFF	OFF	OFF	OFF	Ground→OFF
55		To FR driver's side power window SW (UP) ③	Ground	12V	Ground	Ground	Ground
56		To FR driver's side power window SW (DOWN) ②	OFF	OFF	Ground	OFF	Ground→OFF
58	Output signal	FR driver's side regulator (Upward power source)	0V	Over 9V	0V	0V	0V
57		FR driver's side regulator (Downward power source)	0V	0V	Over 9V	0V	Over 9V→0V

Regulator Operating Condition	Stop	Upward operation	Downward operation	Stop	Starting	Keeping operation until fully open, then stops automatically
					Downward operation	

- Carry out the operation check in this chart from left to right continuously.
- The voltages are approximate values.
- Do not disconnect power window amp. connector.

GI  
MA  
EM  
LC  
EF & EC  
FE  
AT  
FA  
RA  
BR  
ST  
BF  
HA  
EL  
ICX

# INSTRUMENT PANEL

---

## CAUTION:

- a. Disconnect ground terminal from battery in advance.
- b. Disconnect supplemental air bag system line in advance.
- c. Be careful not to scratch pad and other parts.

## REMOVAL — Instrument panel assembly

- ① Remove console center cover, lower.
- ② Remove lower instrument cover (RH/LH).  
Disconnect foot lamp harness connector.
- ③ Remove instrument pocket.
- ④ Remove lower instrument panel (driver/passenger).  
Remove knee reinforcement plates.  
Lower steering column. Refer to ST section ("Removal and Installation", "STEERING WHEEL AND STEERING COLUMN").
- ⑤ Remove cluster lid.  
Disconnect cluster lid switches.
- ⑥ Remove combination meter.  
Disconnect combination meter harness connectors.  
Disconnect warning chime harness connector.  
Remove remote control door mirror switch.  
Disconnect remote control door mirror harness connector.
- ⑦ Remove glove box.  
Disconnect glove box lamp harness connector.
- ⑧ Remove center console bezel/coinholder, center vent assembly.
- ⑨ Remove ashtray.  
Disconnect ashtray harness connector.
- ⑩ Remove audio system bracket assembly and components.  
Disconnect audio harness connectors.  
Disconnect antenna feeder.
- ⑪ Remove heater control module.
- ⑫ Remove A-pillar trim LH/RH. Refer to "Interior", "INTERIOR AND EXTERIOR".
- ⑬ Remove defroster grill.  
Remove photocell.  
Disconnect autolamp module.
- ⑭ Remove instrument panel.

## INSTALLATION

Reverse the procedures described above.

**Pay attention so as not to scratch the parts (plastic). During installation, fit the ducting parts precisely.**

# INSTRUMENT PANEL

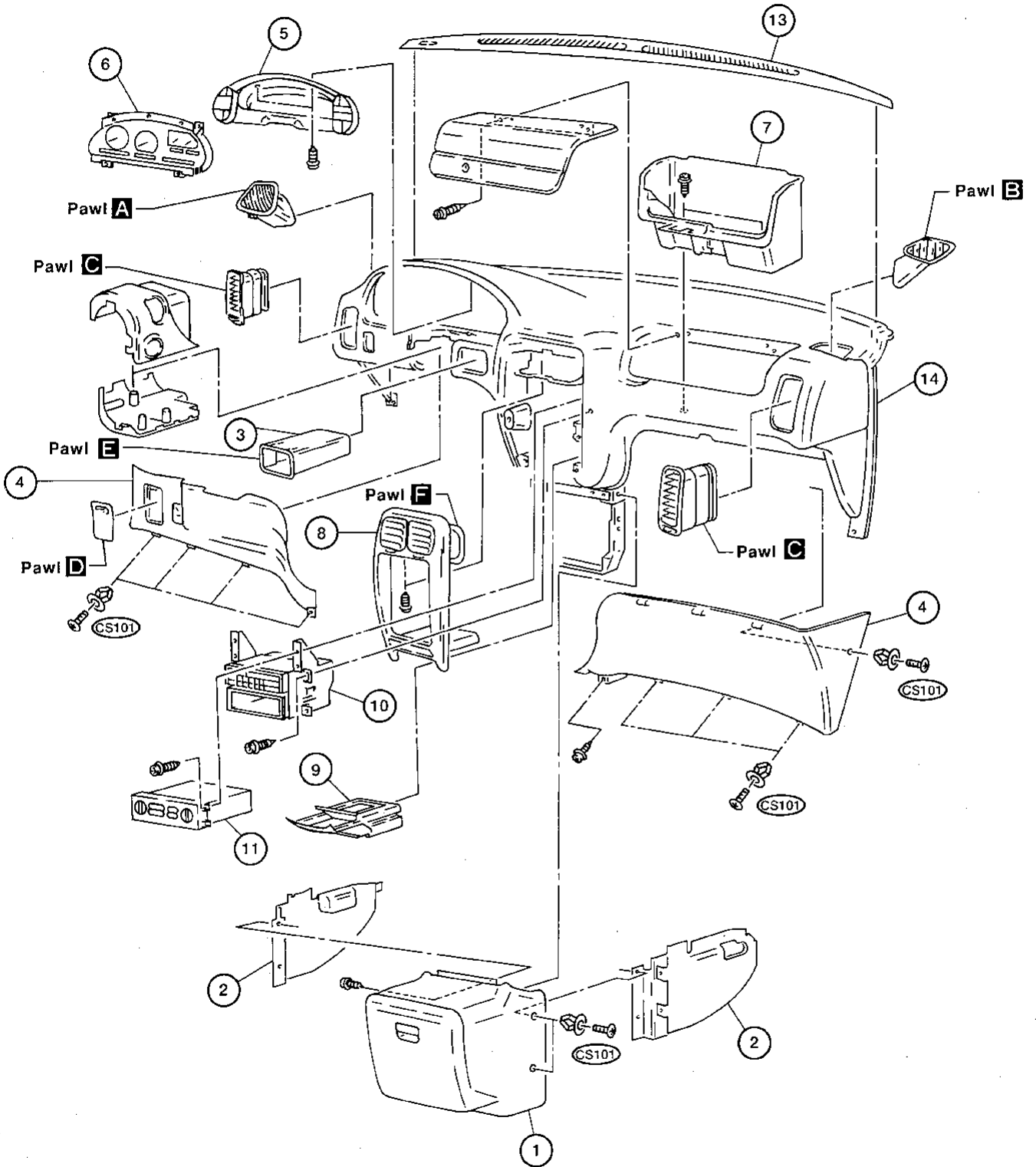

GI  
MA  
EM  
LC  
EF &  
EC  
FE  
AT  
FA  
RA  
BR  
ST  
BF  
HA  
EL  
IDX

# INSTRUMENT PANEL

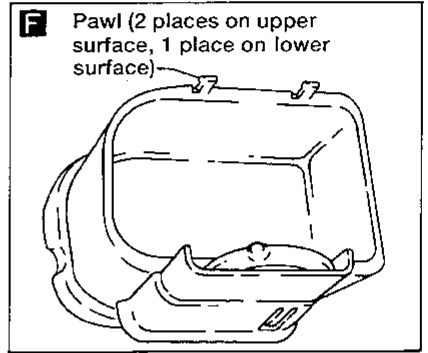
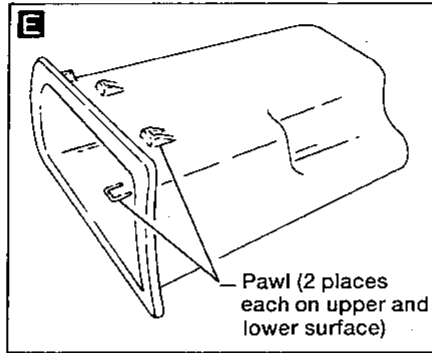
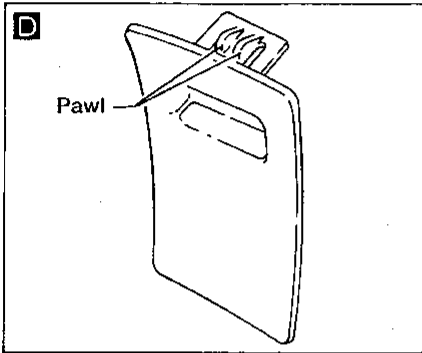
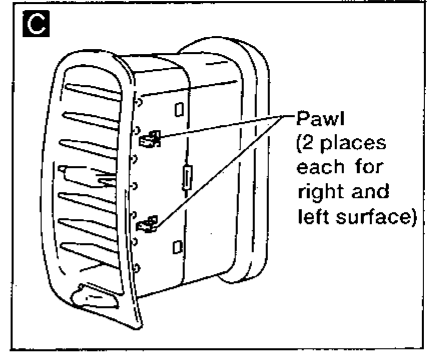
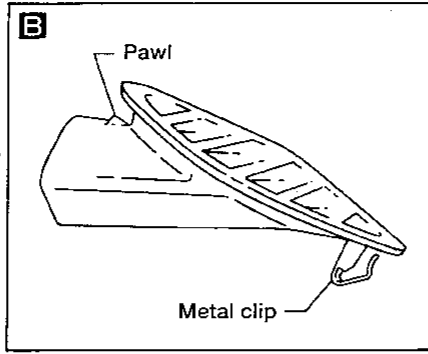
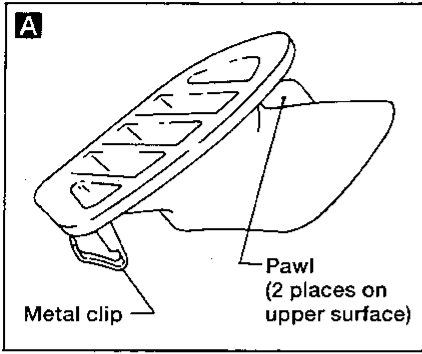



# INTERIOR AND EXTERIOR

- When handling interior or exterior parts, do not use excessive force and take care not to damage them.

## Interior

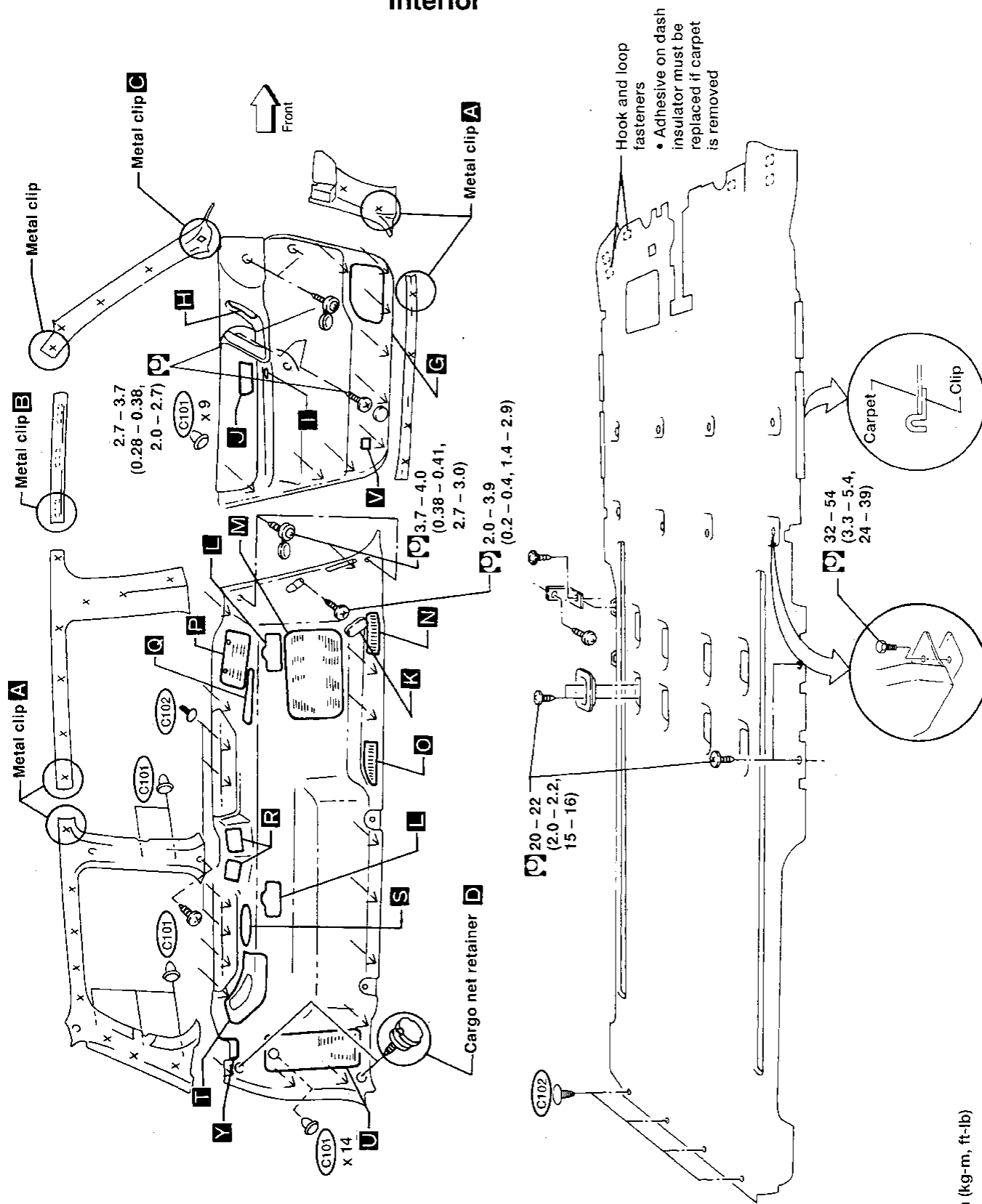

GI  
MA  
EM  
LC  
EF &  
EC  
FE  
AT  
FA  
PA  
BR  
ST  
BF  
HA  
EL  
IDX

□ : N·m (kg·m, ft·lb)

ABF268

# INTERIOR AND EXTERIOR

## Interior (Cont'd)

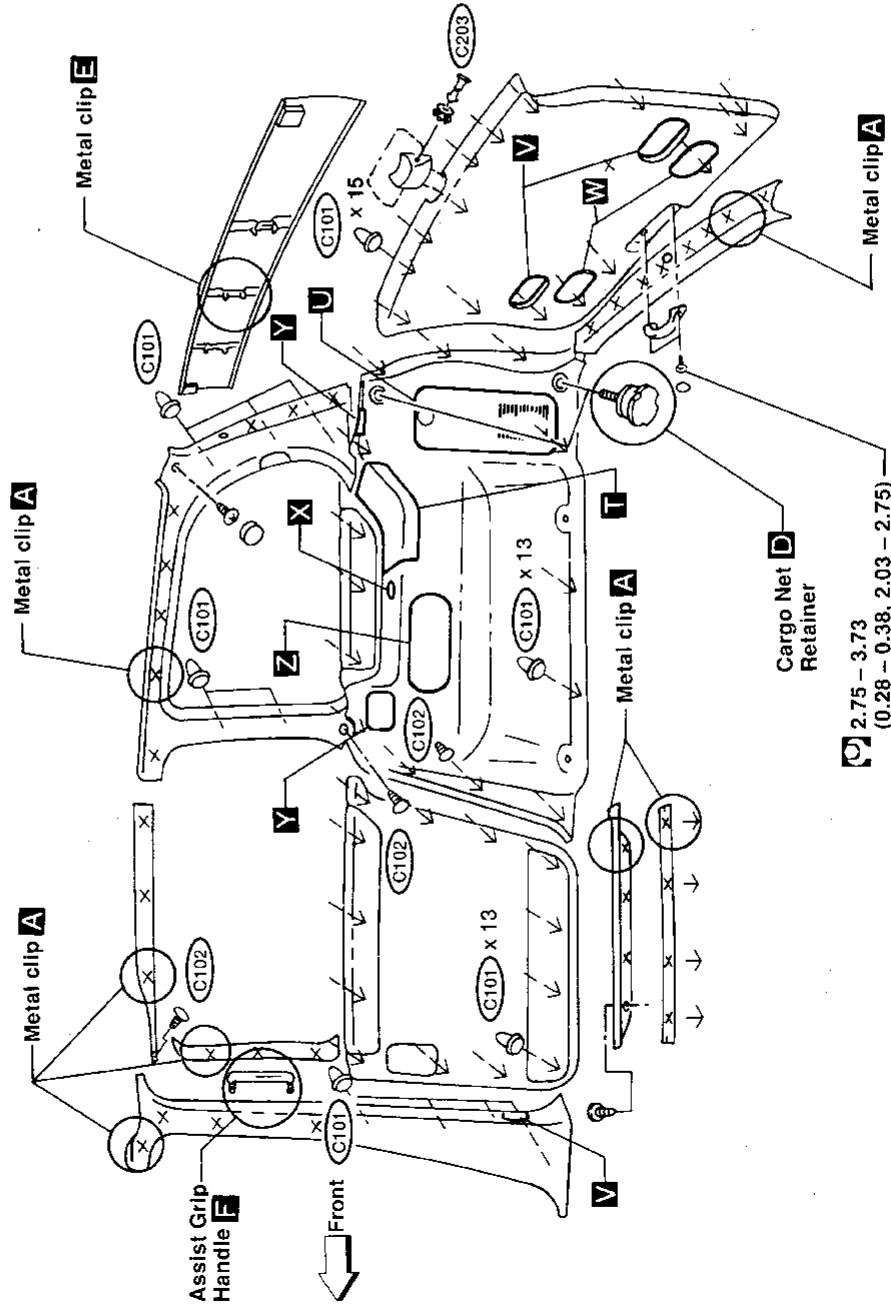
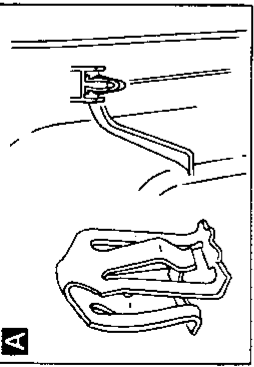
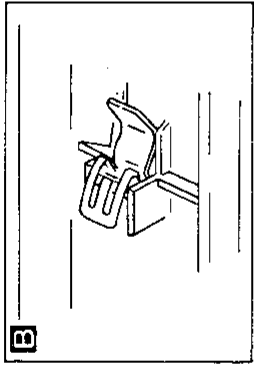
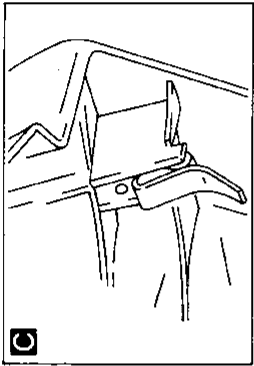
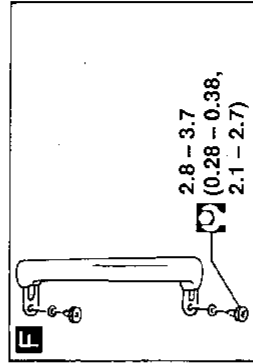
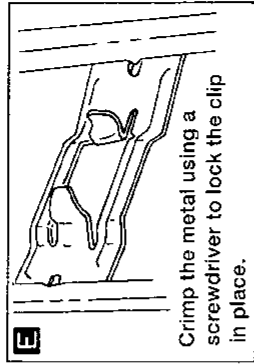
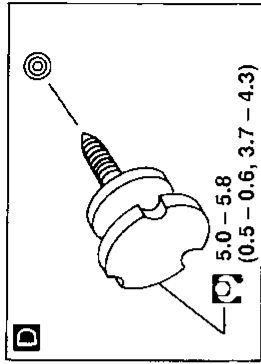

**N·m (kg-m, ft-lb)**

# INTERIOR AND EXTERIOR

## Interior (Cont'd)

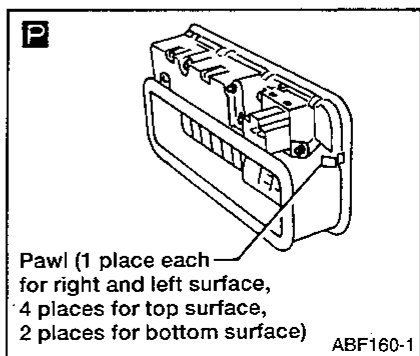
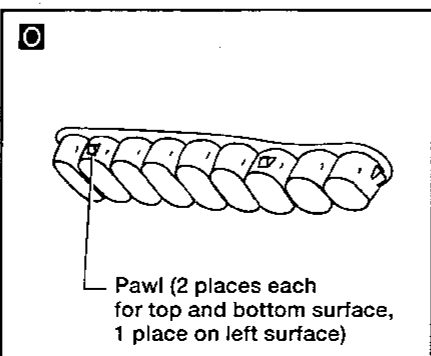
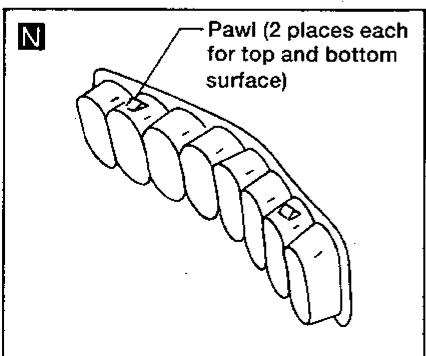
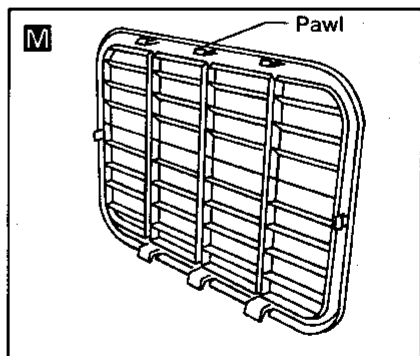
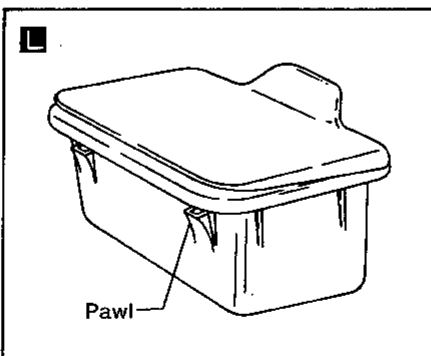
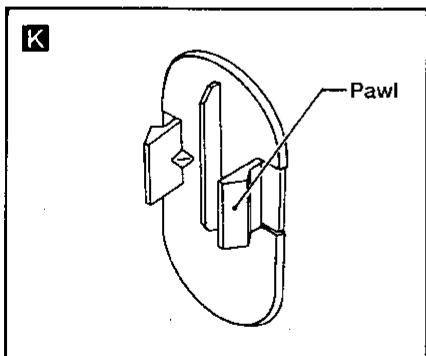
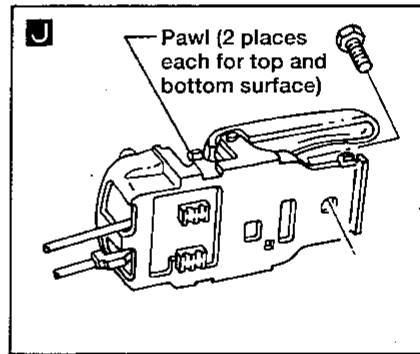
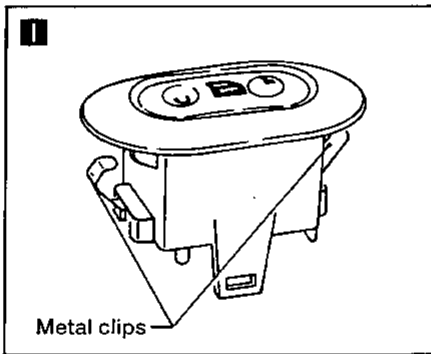
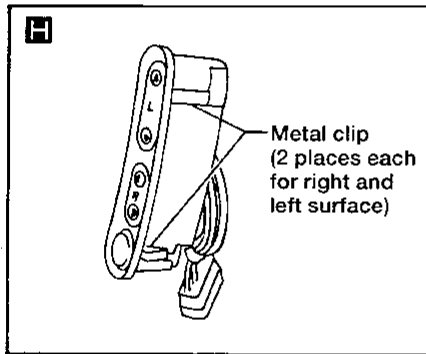
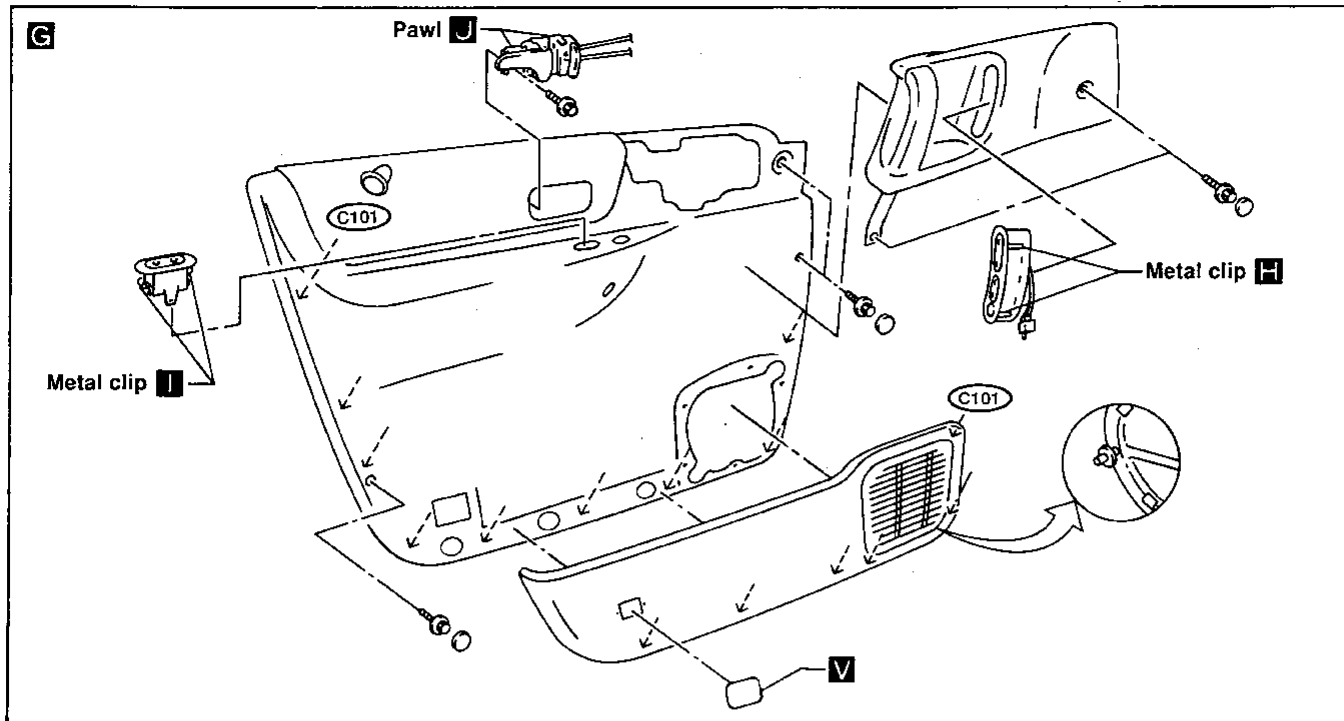

ABF160-1

GI  
MA  
EM  
LC  
EF &  
EC  
FE  
AT  
FA  
RA  
BR  
ST  
BF  
HA  
EL  
IDX

# INTERIOR AND EXTERIOR

## Interior (Cont'd)

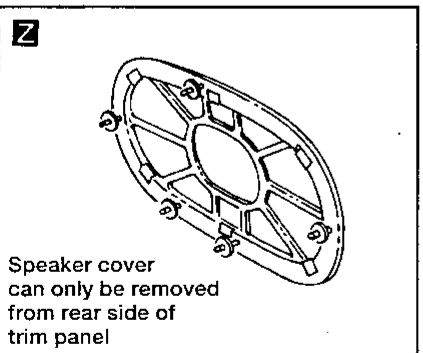
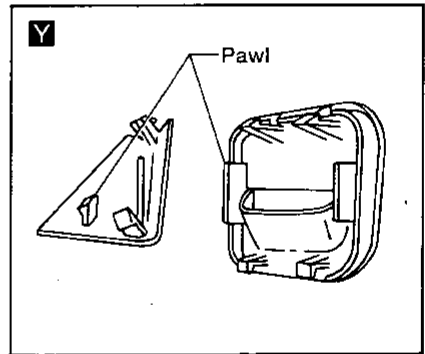
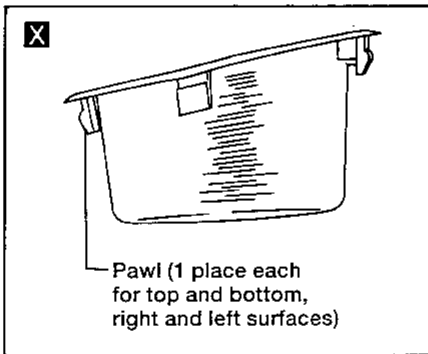
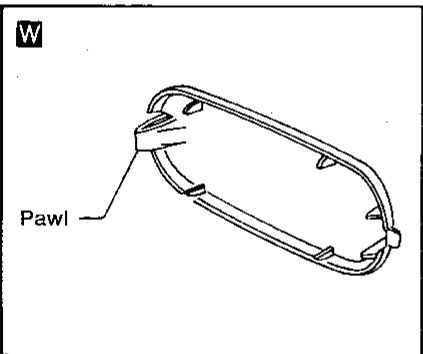
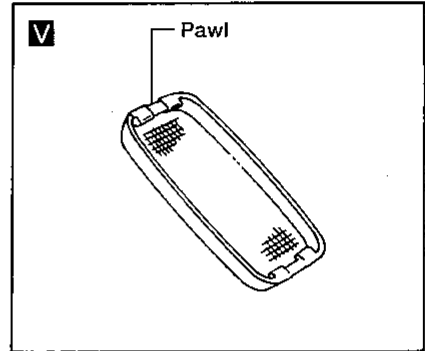
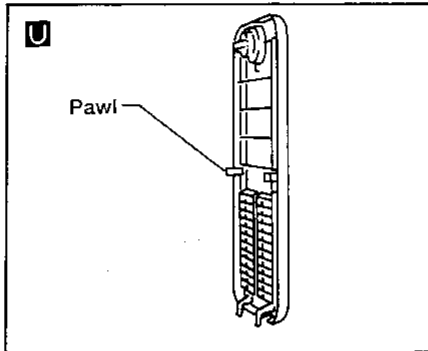
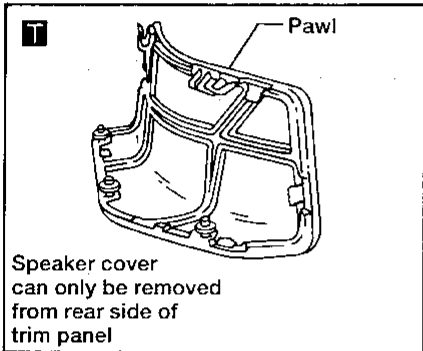
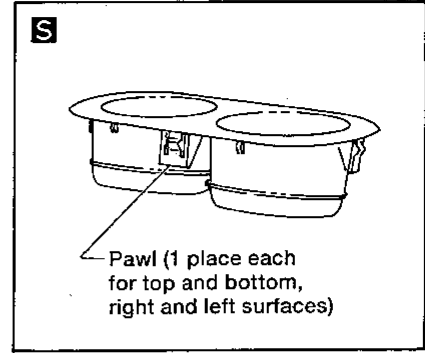
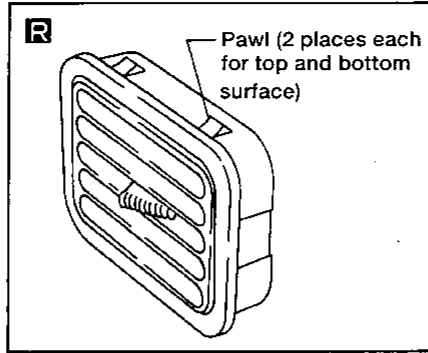
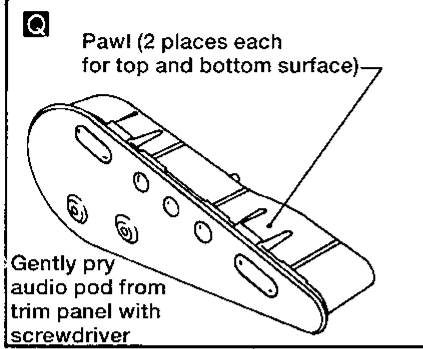

# INTERIOR AND EXTERIOR

## Interior (Cont'd)

### ROOF TRIM

With sun roof

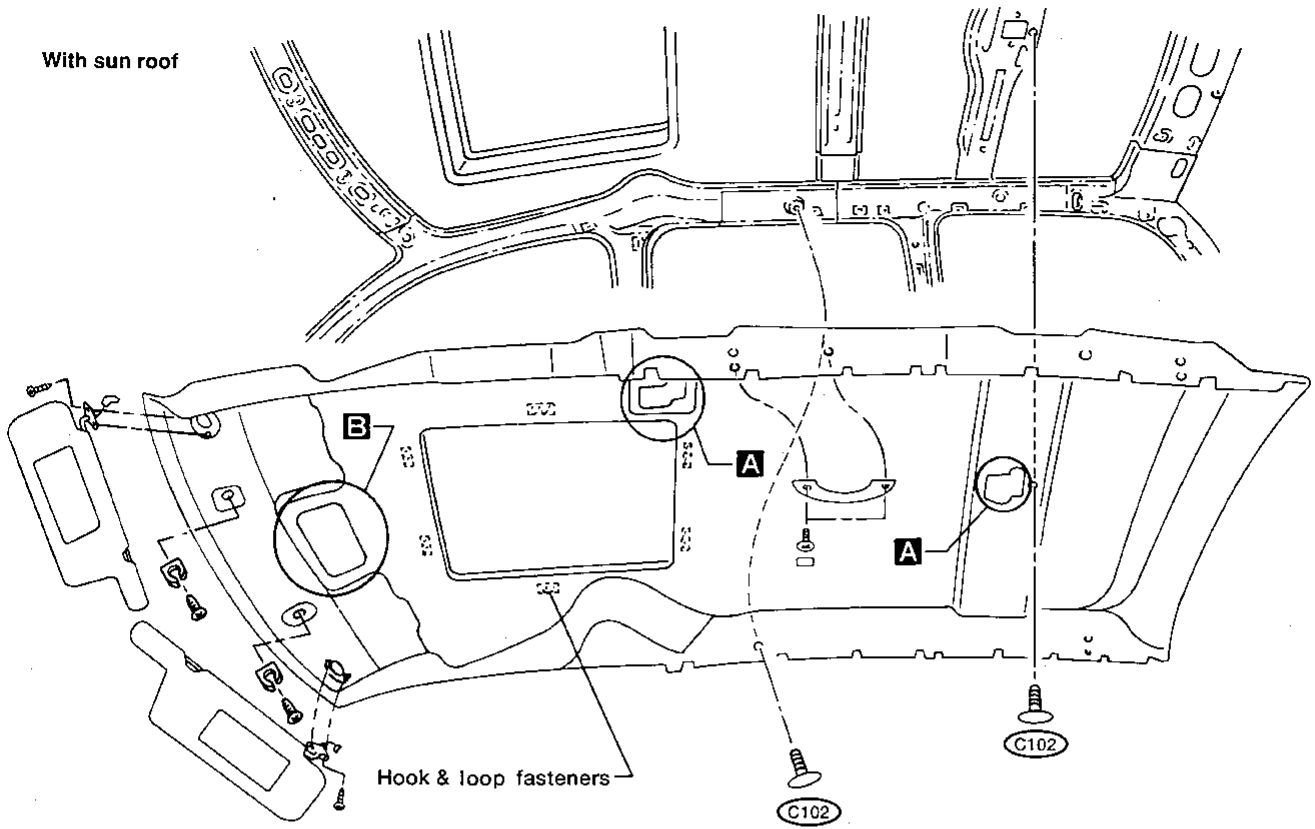

Without sun roof

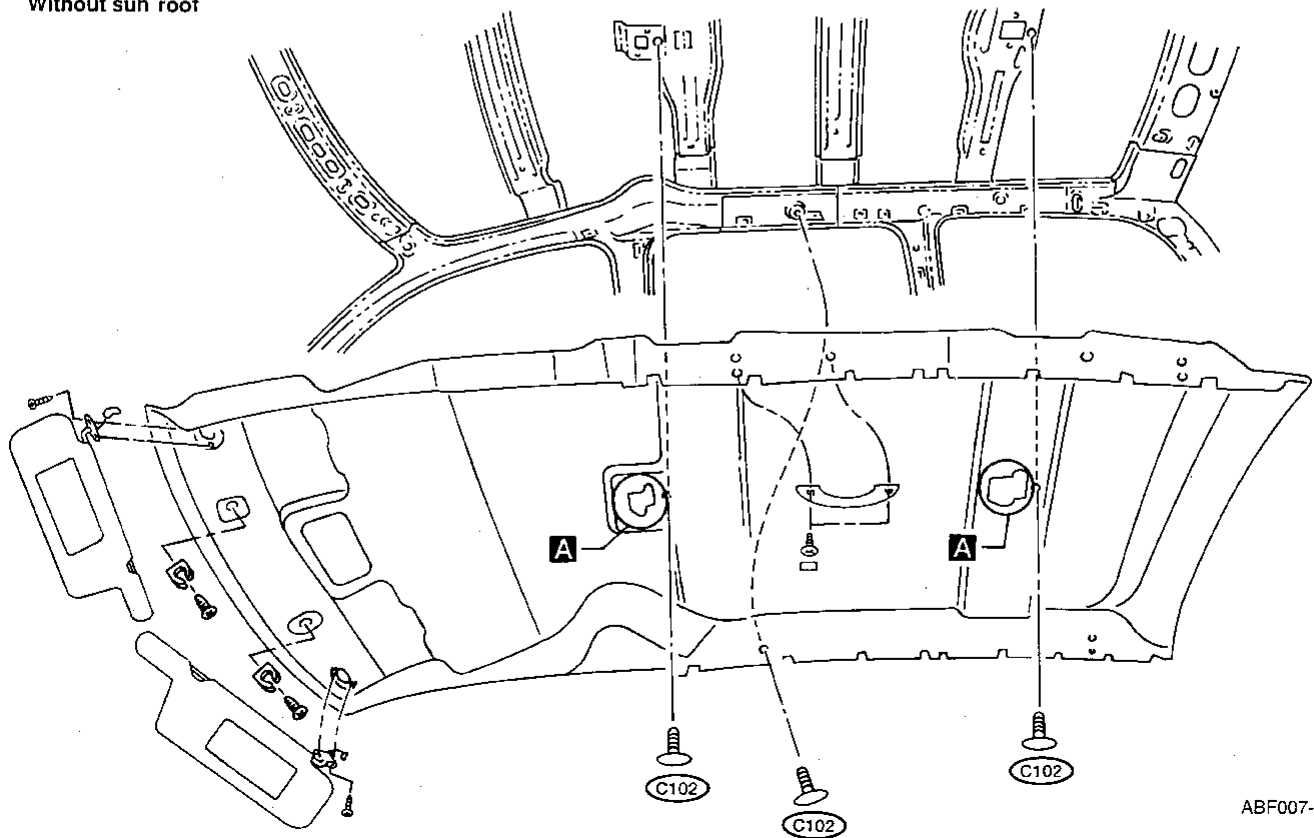

GI  
MA  
EM  
LC  
EF &  
EC  
FE  
AT  
FA  
RA  
BR  
ST  
BF  
HA  
EL  
IDX

BF-35

ABF007-1

# INTERIOR AND EXTERIOR

## Interior (Cont'd)

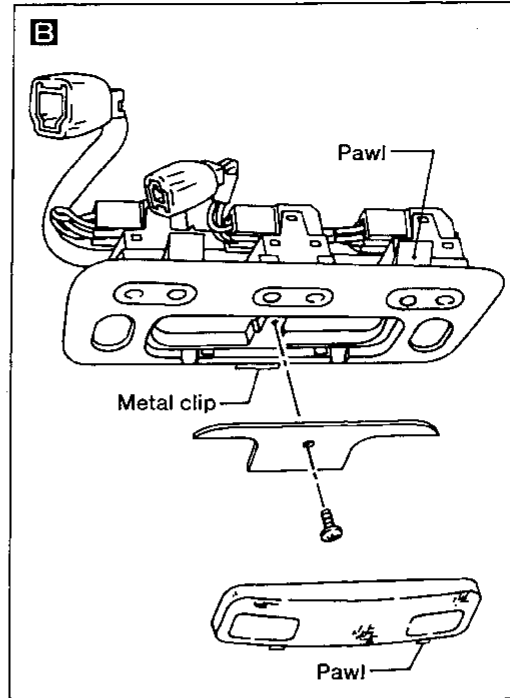
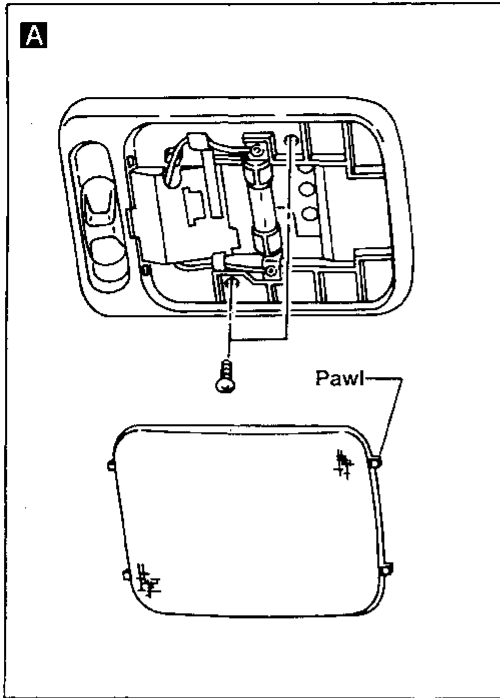

# INTERIOR AND EXTERIOR

## Exterior

- Apply sealing compound where necessary while installing parts.
- When applying sealing compound, be careful that the sealing compound does not protrude from parts.

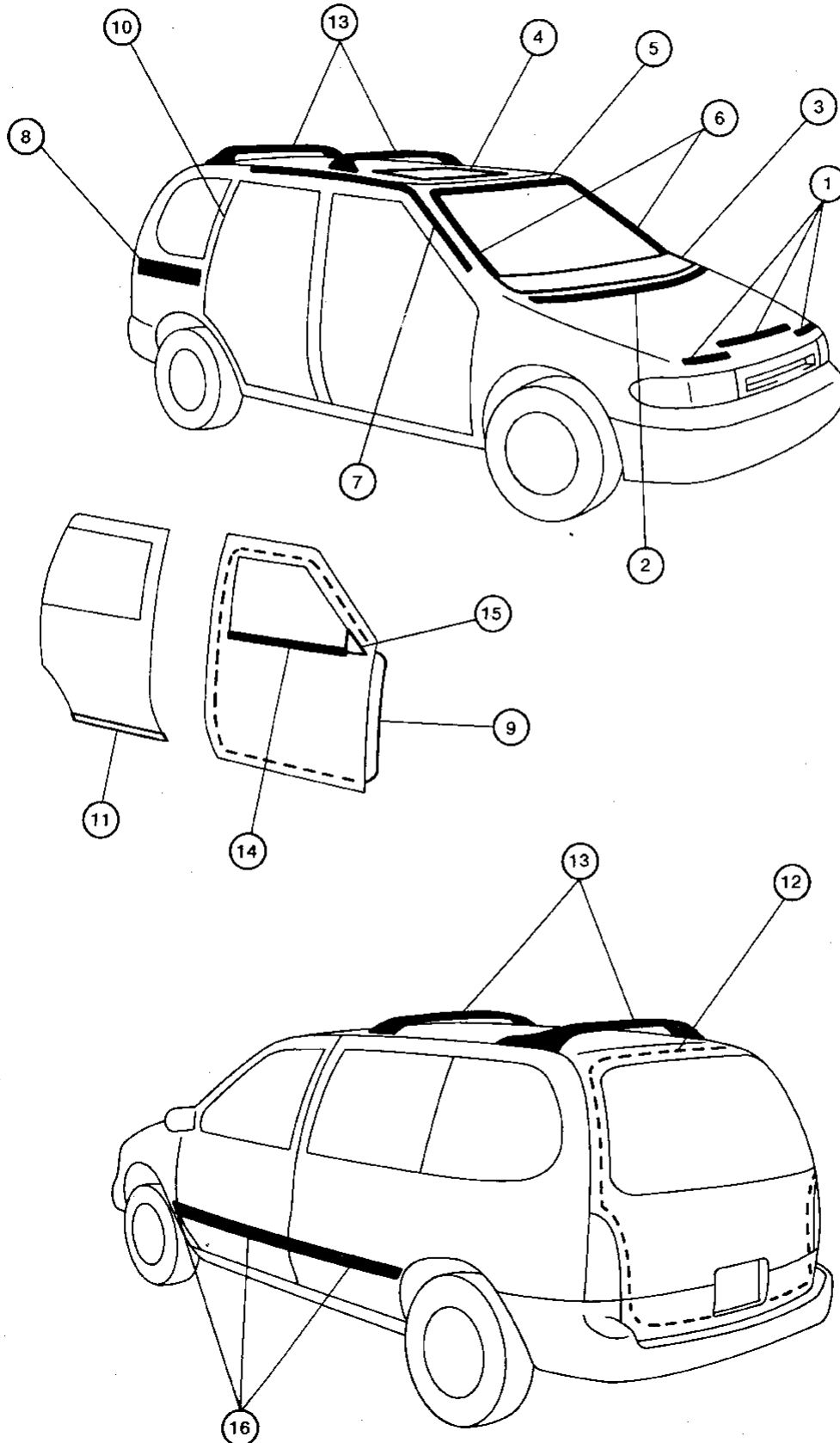

GI

MA

EM

LC

EF &

EC

FE

AT

FA

RA

BR

ST

**BF**

HA

EL

IDX

# INTERIOR AND EXTERIOR

## Exterior (Cont'd)

### ① Hood front sealing rubber

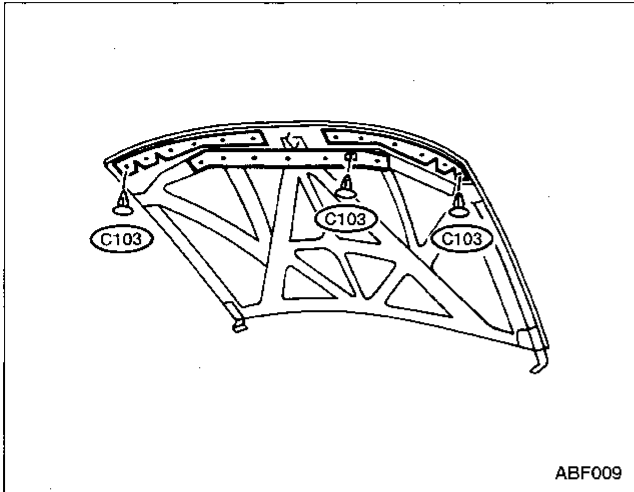

### ② ③ Hood rear sealing rubber & cowl top grille

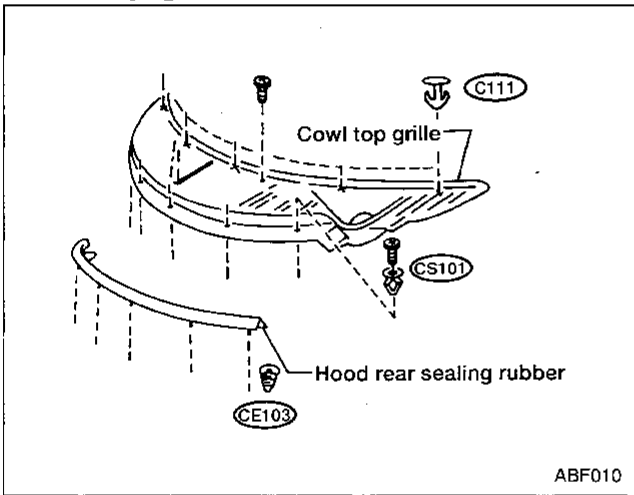

### ④ Sun roof frame weatherstrip and sun roof lid weatherstrip

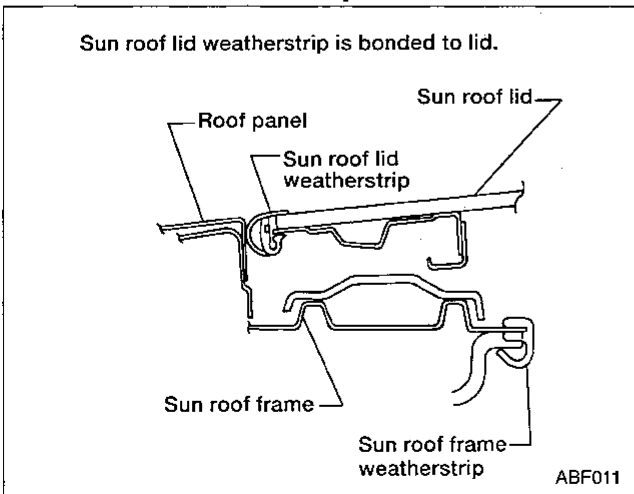

### ⑤ Windshield upper molding

#### Method 1

Cut off top portion of molding and clean glass and panel surfaces.

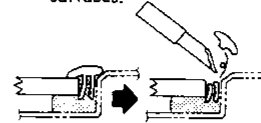

Apply sealant to top portion of molding.

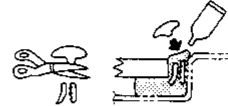

Cut off lower portion of new molding.

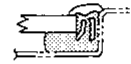

Finish well to give it a good appearance.

#### Method 2

1. Cut off sealant at glass end.
2. Clean the side on which panel was mounted.
3. Set molding fastener and apply sealant to body panel, and apply primer to molding and body.

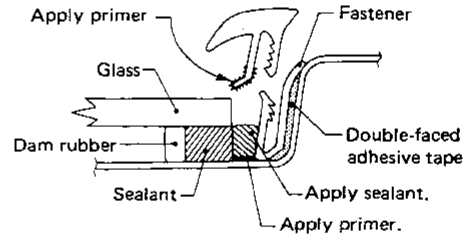

4. Install molding by aligning the molding mark located on center with vehicle center. Be sure to install tightly so that there is no gap around the corner.

SBF161E

### ⑥ Windshield side molding

It is mounted with screws.



# INTERIOR AND EXTERIOR

## Exterior (Cont'd)

⑦ Body side drip molding

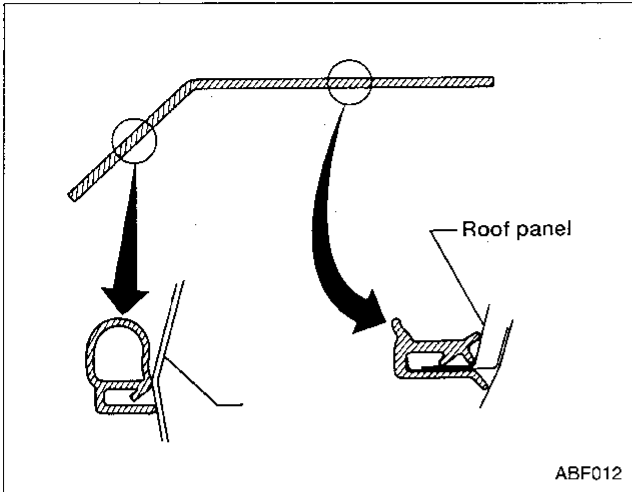

⑩ Sliding door weatherstrip

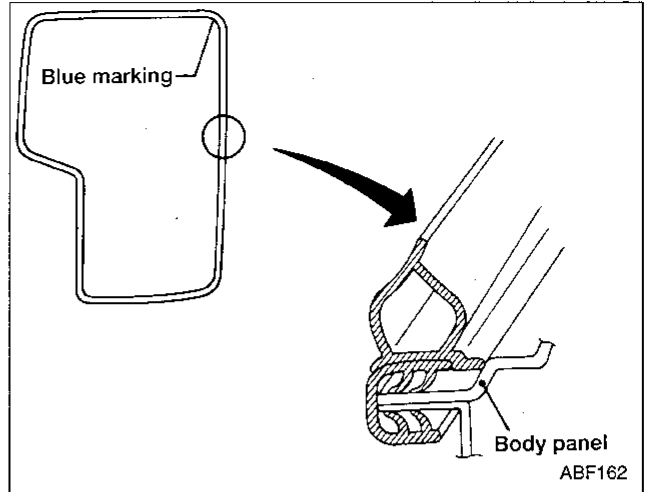

⑧ Waist rail finisher

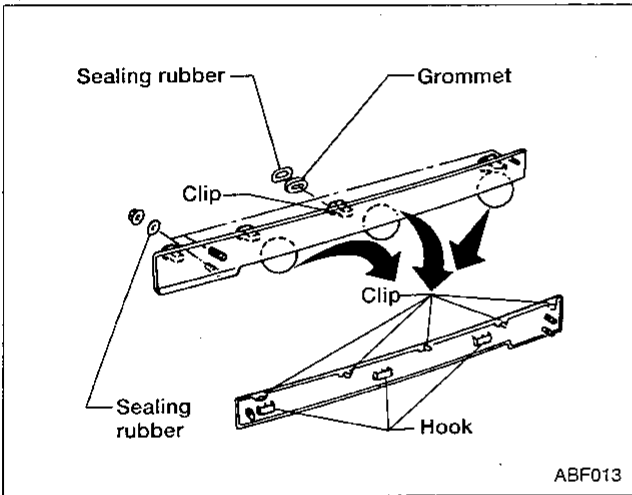

⑪ Sliding door lower seal

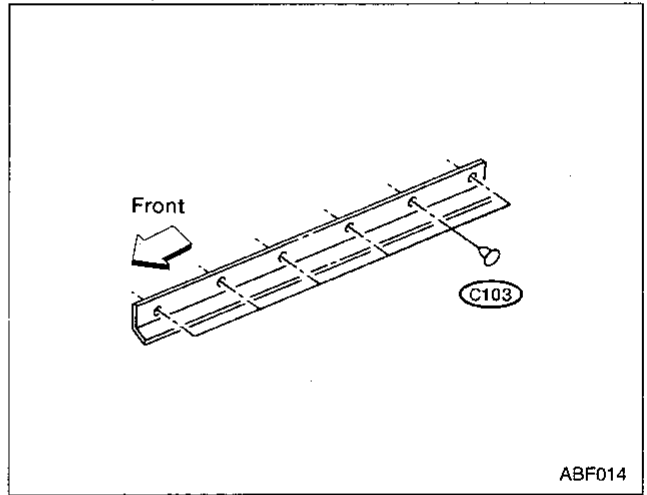

⑨ Front door weatherstrip

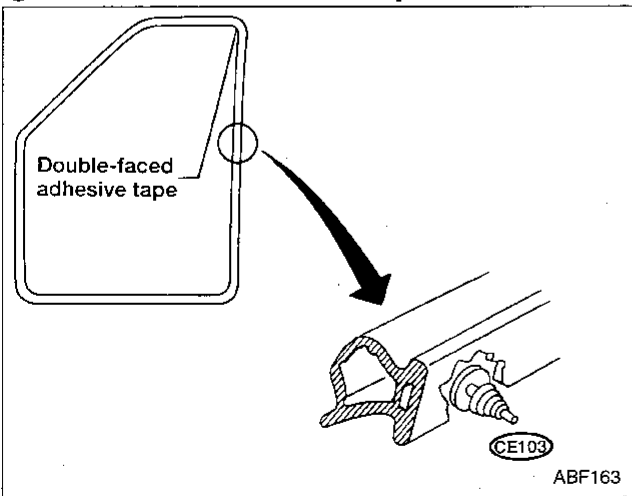

⑫ Back door opening weatherstrip

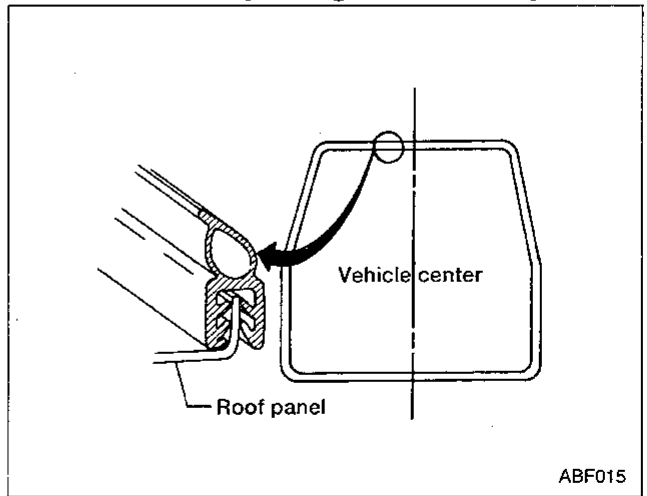

CI  
MA  
EM  
LC  
EF &  
EC  
FE  
AT  
FA  
RA  
BR  
ST  
BF  
HA  
EL  
IDX

# INTERIOR AND EXTERIOR

## Exterior (Cont'd)

### ⑬ Luggage rack

With sun roof

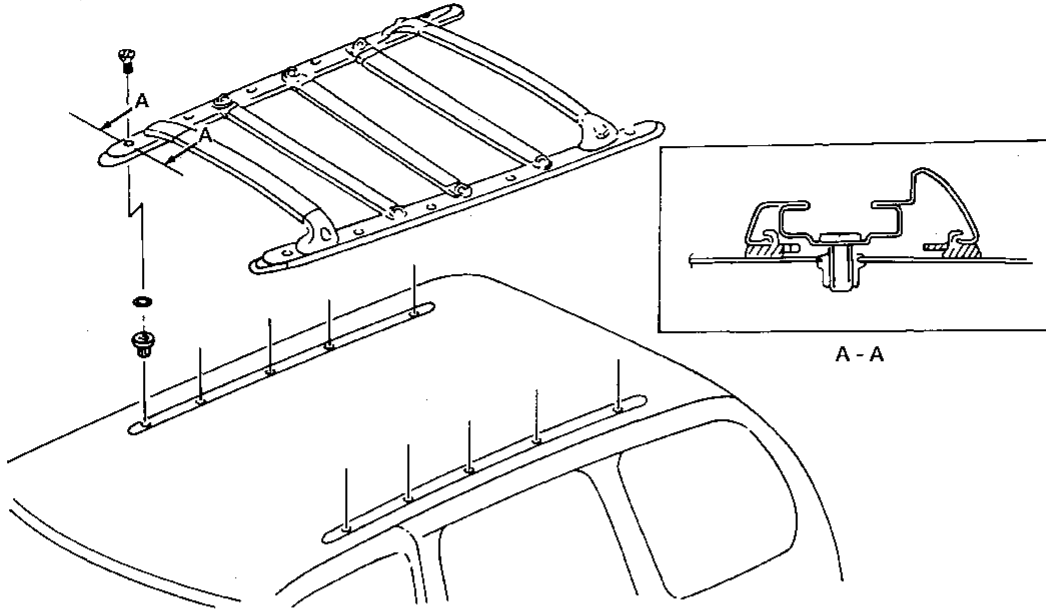

Without sun roof

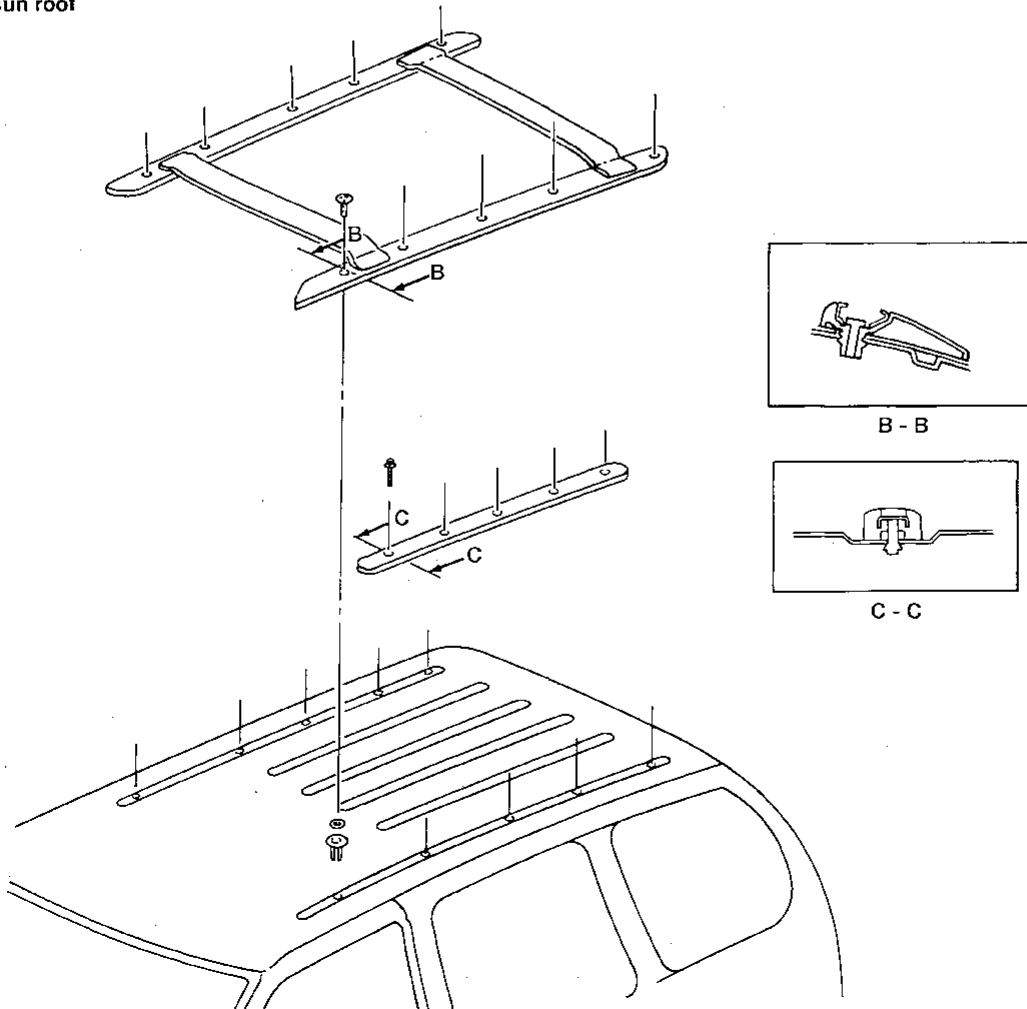

BF-40

ABF016

INTERIOR AND EXTERIOR

Exterior (Cont'd)

14 Outside door molding

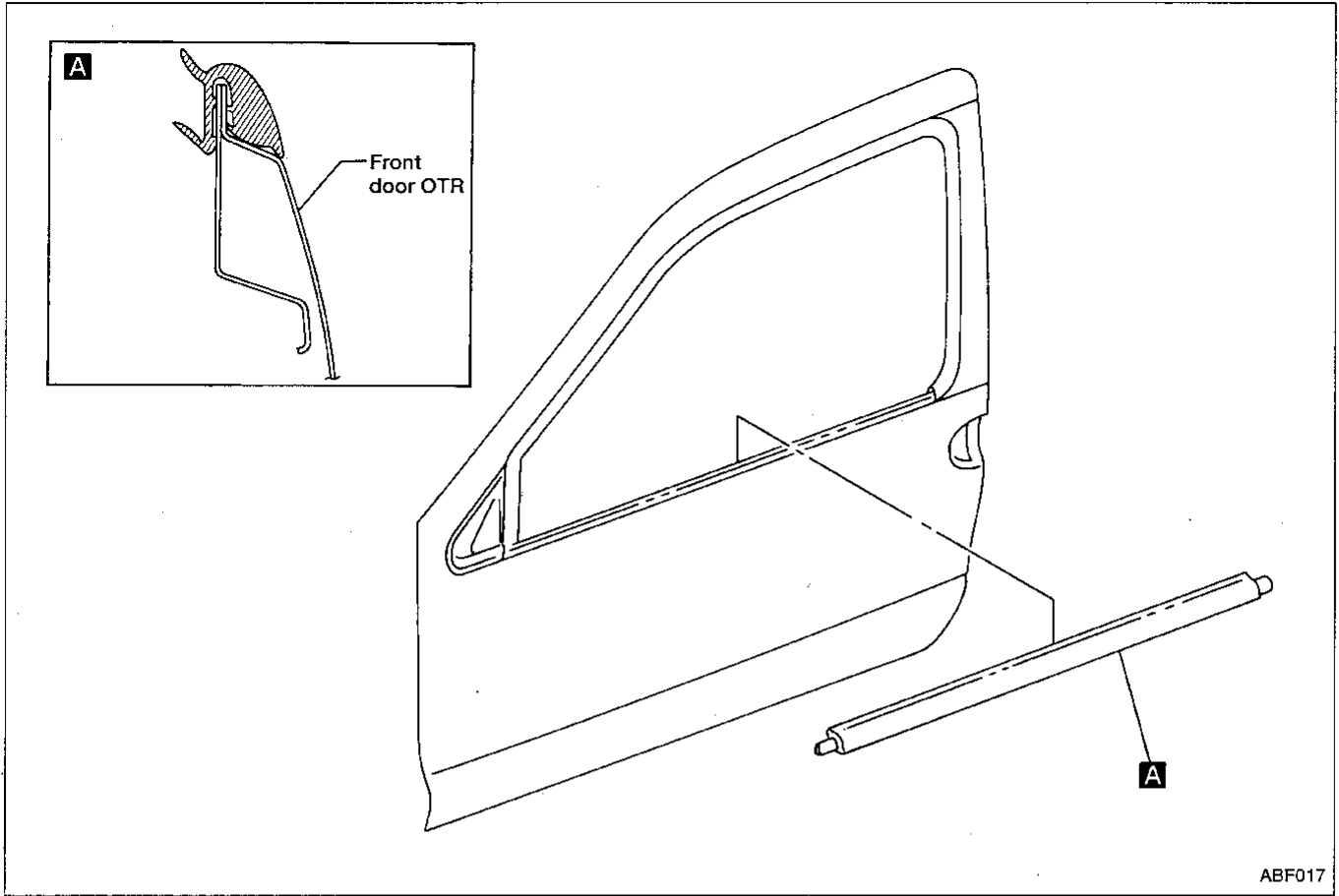

GI  
NA  
EM  
LC  
EF &  
EC  
FE  
AT  
FA  
RA  
BR  
ST  
BF  
HA  
EL  
IDX

### 15 Front door corner covers

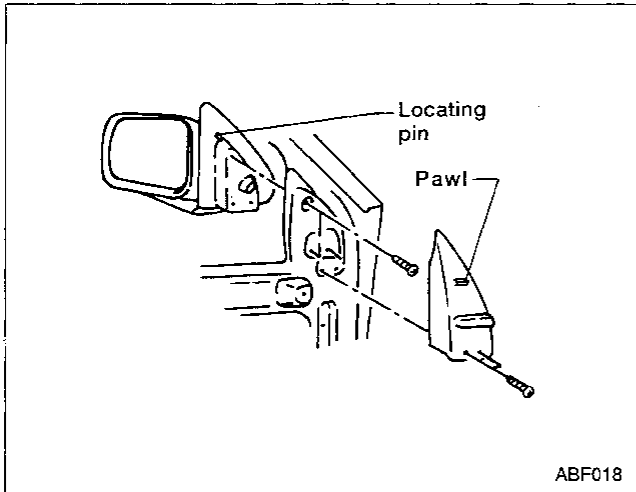

### 16 Side guard molding

A cross-sectional diagram of the side guard molding assembly. It shows a rectangular molding piece with a hatched pattern on its top and bottom surfaces, indicating the presence of double-faced adhesive tape. The molding is shown being attached to a body panel. A legend below the diagram shows a hatched square followed by the text ': Double-faced adhesive tape'.

- **Removal:**
  1. Heat molding portion to 30 to 40°C (86 to 104°F) with a heat gun.

A diagram showing a hand holding a heat gun and directing it towards the side guard molding. The heat gun is labeled 'Heat gun' and the diagram is labeled 'SBF455A' in the bottom right corner.

2. Raise end of molding and, while cutting off bonding agent, detach molding.

- **Installation:**
  1. Remove all traces of bonding agent from body panel. Then clean contact face of body.
  2. Heat body panel and molding to 30 to 40°C (86 to 104°F) with a heat gun. Then install molding.

MBF047A

# SEAT

- When removing or installing the seat trim, carefully handle it to keep dirt out and avoid damage.

## Front Seat

### Installation sequence

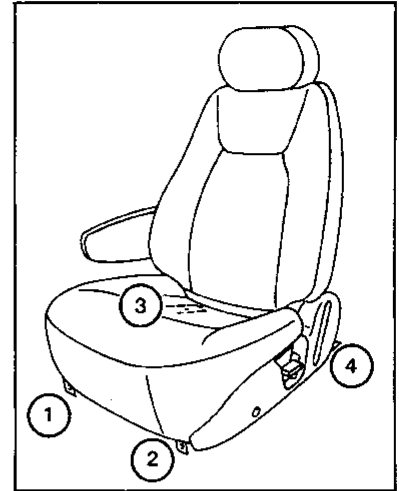

- GI
- MA
- EM
- LC
- EF & EC
- FE
- AT
- FA
- RA
- BR
- ST
- BF**
- HA
- EL
- IDX

Head rest holder  
 • Roll up seat back trim and pinch bottom.

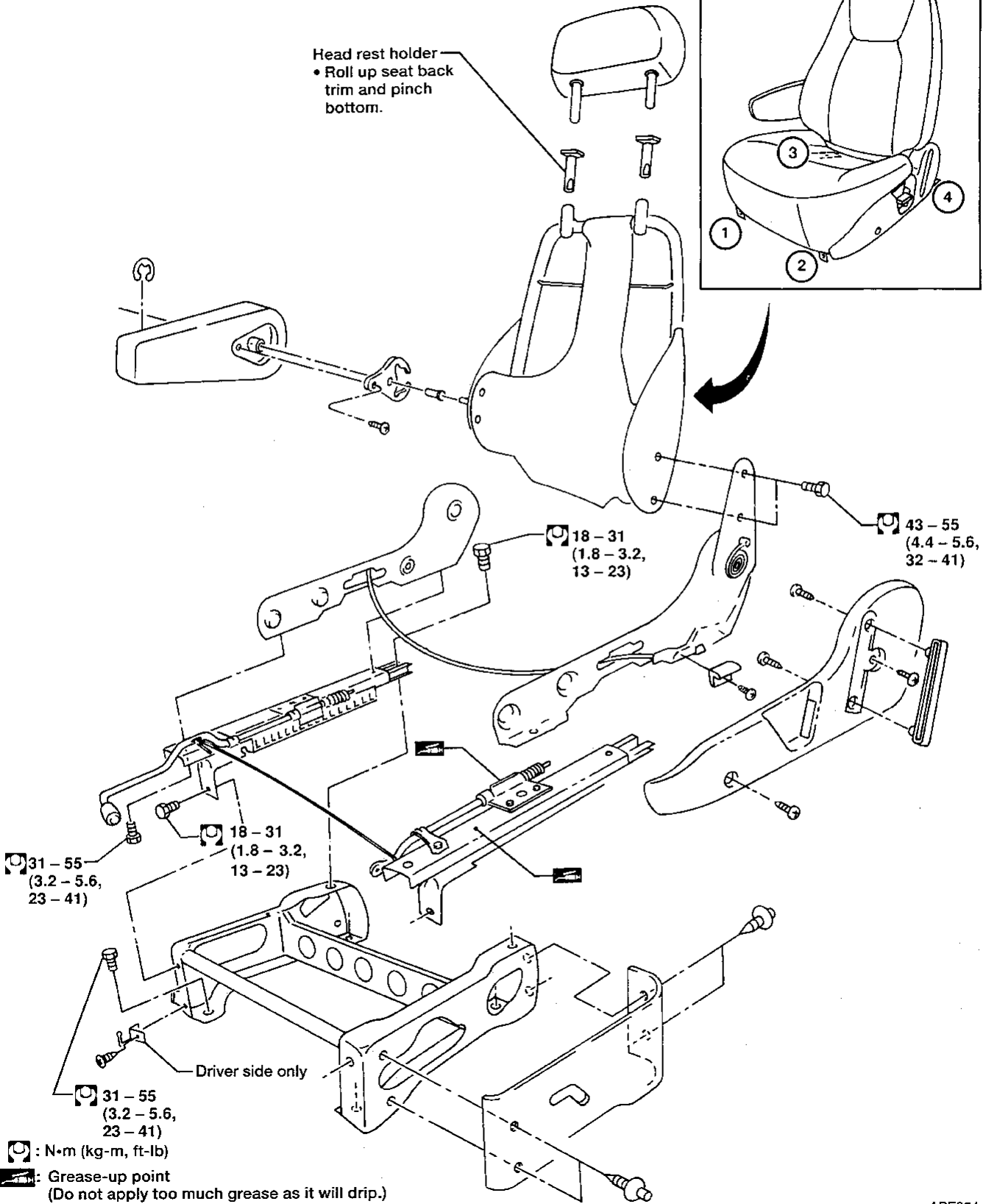

# SEAT

## Front Power Seat

Installation sequence

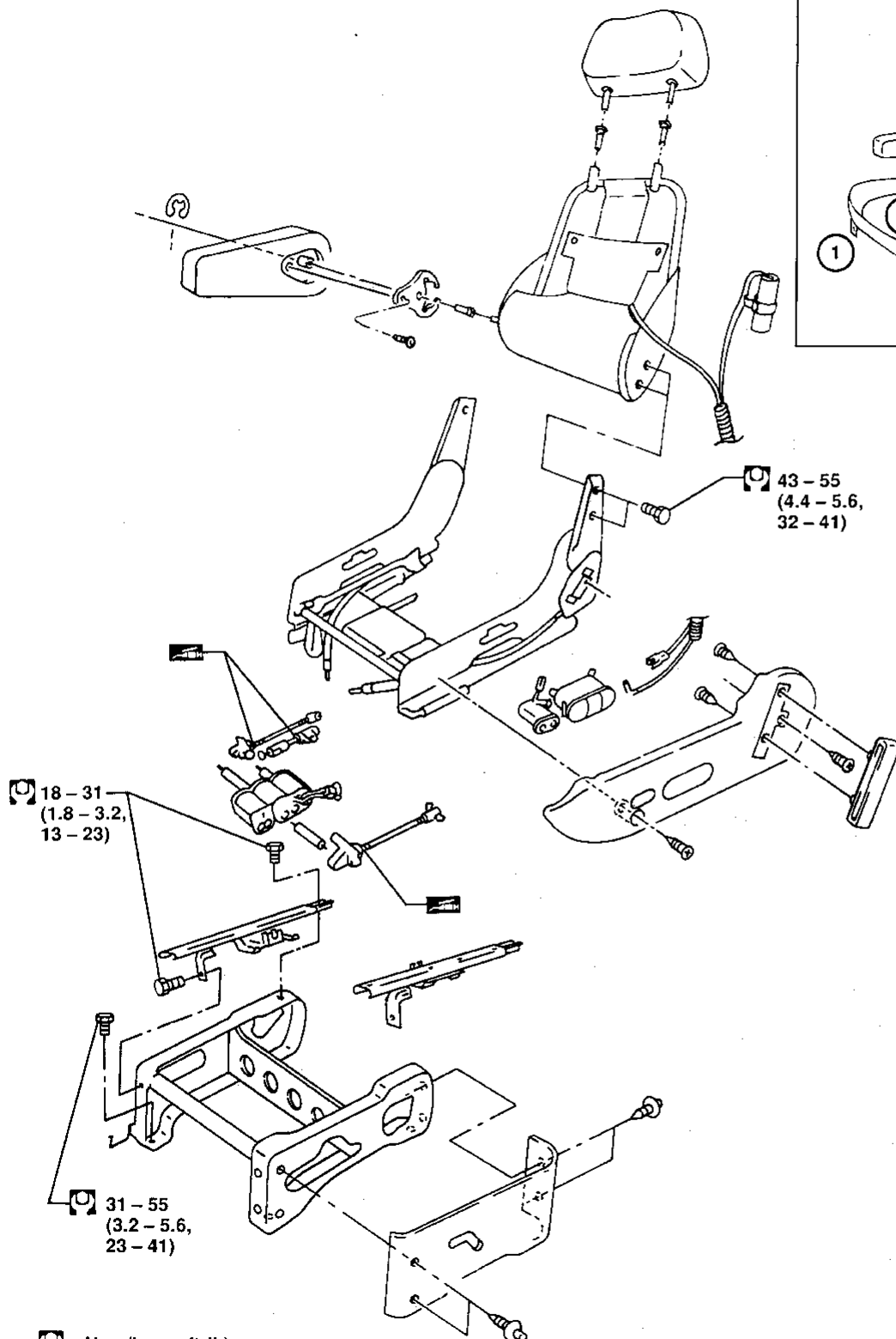
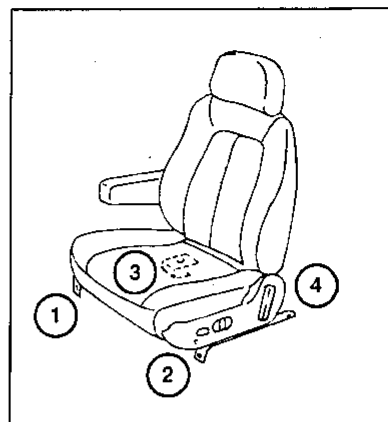

 : N·m (kg-m, ft-lb)

 : Grease-up point  
(Do not apply too much grease as it will drip.)

**Front Power Seat/System Description**

The front LH seat has six way power adjustments that electronically control:

- the forward and rearward movement
- the seat back angle, and
- the height adjustment of the seat.

A power lumbar air bladder in the front LH seat also provides adjustable support for the lower back.

The front RH seat has four way power adjustments that electronically control:

- the forward and rearward movement, and
- the seat back angle.

Power is supplied at all times:

- through the 30A fusible link (No. 13, located in the fusible link box-1)
- to circuit breaker-2 terminal ①
- through circuit breaker-2 terminal ②
- to the right power seat switch terminal ⑥
- to the left power seat switch terminal ⑥, and
- to the lumbar support switch terminal ①.

Ground is supplied at all times:

- to the right power seat switch terminal ③
- to the left power seat switch terminal ③, and
- to the lumbar support motor terminal ②
- through body grounds: (M5) and (M75).

**LUMBAR SUPPORT OPERATION**

When the lumbar support switch is placed in the FILL position, power is supplied:

- from the lumbar support switch terminal ②
- to the lumbar support motor terminal ①.

With power and ground supplied, the lumbar support motor pumps air into the lumbar support bag.

When the lumbar support switch is placed in the RELEASE position, a check valve is opened, and air is allowed to escape from the lumbar support bag.

**POWER SEAT OPERATION**

Power and ground are supplied from the power seat switches to the power seat motors according to the following charts.

**Left power seat switch**

Switch position	Power terminal	Ground terminal
Sliding switch forward	①	②
Sliding switch rearward	②	①
Lifting switch up	⑤	④
Lifting switch down	④	⑤
Reclining switch up	⑦	⑧
Reclining switch down	⑧	⑦

**Right power seat switch**

Switch position	Power terminal	Ground terminal
Sliding switch forward	⑧	⑦
Sliding switch rearward	⑦	⑧
Reclining switch up	②	①
Reclining switch down	①	②

GI

MA

EM

LC

EF &

EC

FE

AT

FA

RA

BR

ST

BF

HA

EL

IDX

Front Power Seat/Wiring Diagram -SEAT-

BF-SEAT-01

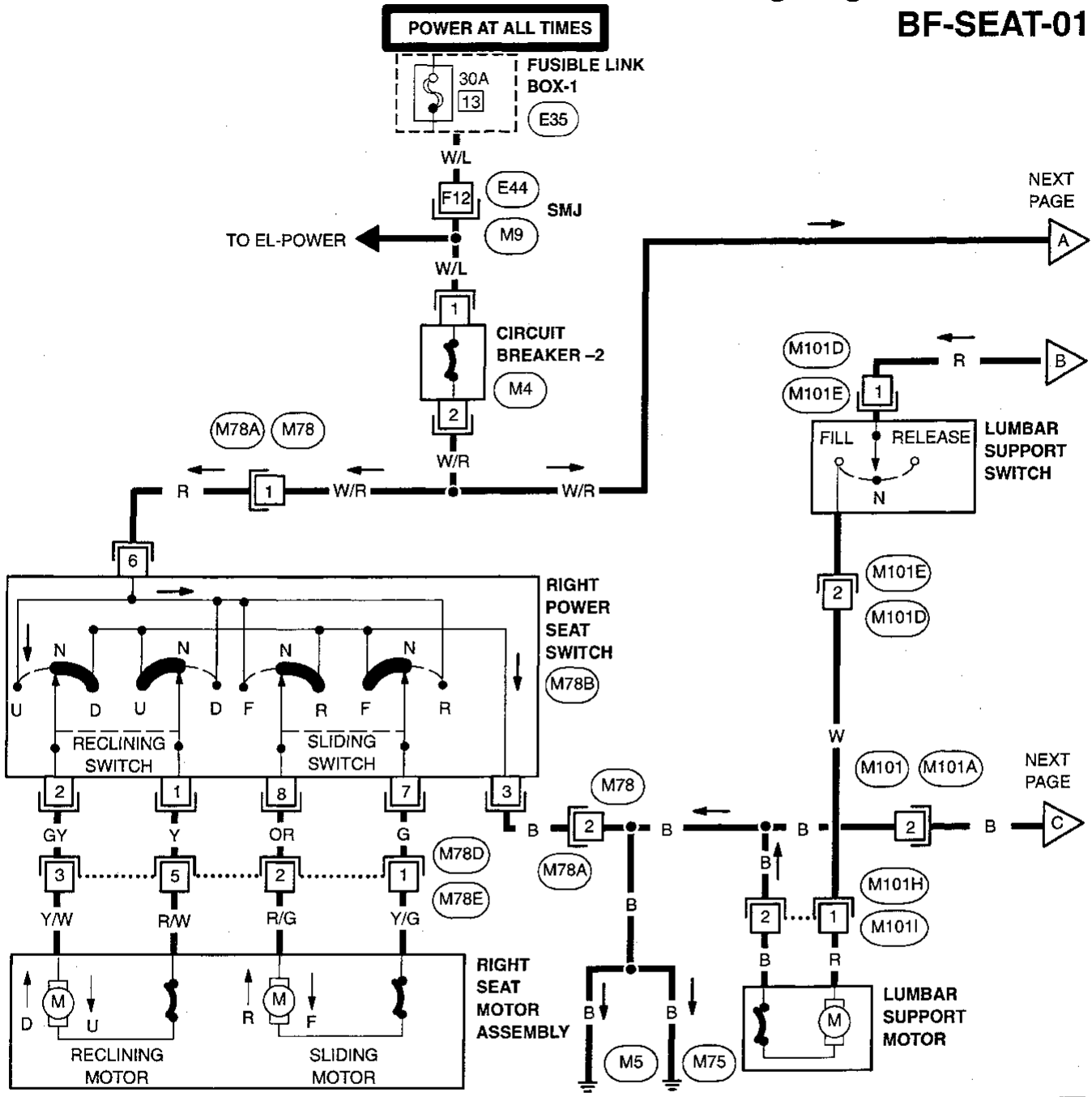

Refer to Foldout  
Page in EL Section  
for details.



Refer to POWER  
SUPPLY ROUTING  
in EL Section.

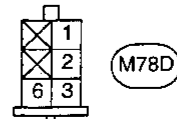
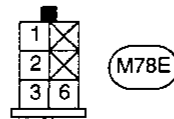
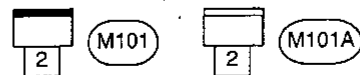
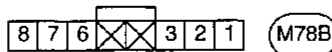
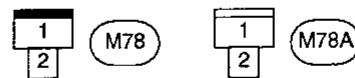
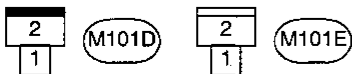
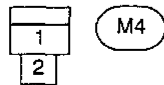

ABF222-A



# SEAT

## Front Power Seat/Wiring Diagram -SEAT- (Cont'd)

BF-SEAT-02

GI

MA

EM

LC

EF &  
EC

FE

AT

FA

RA

BR

ST

**BF**

HA

EL

IDX

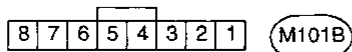
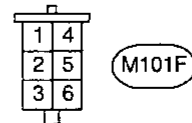
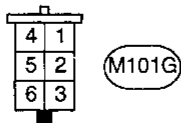
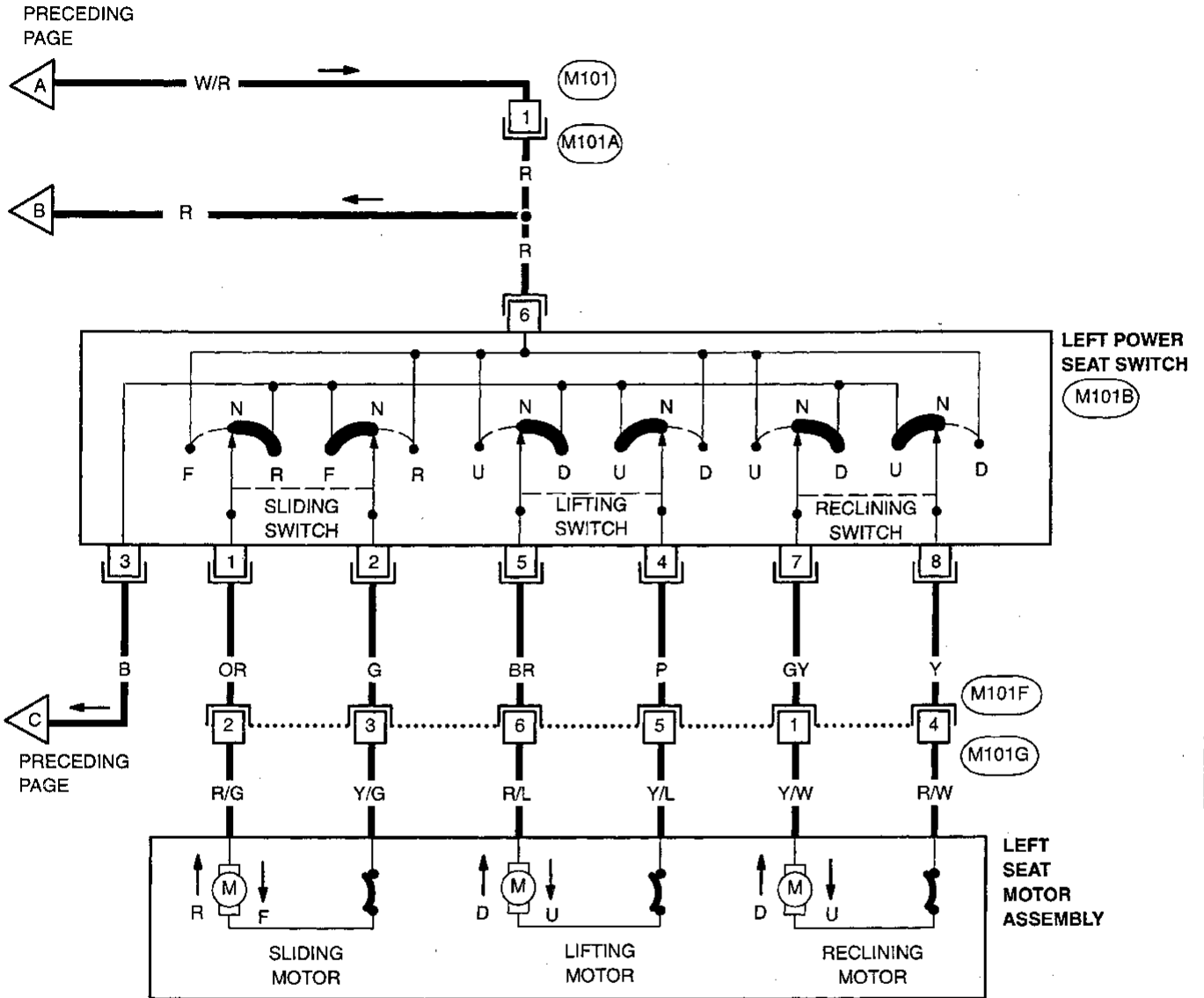

# SEAT

## 2nd Seat

TYPE I

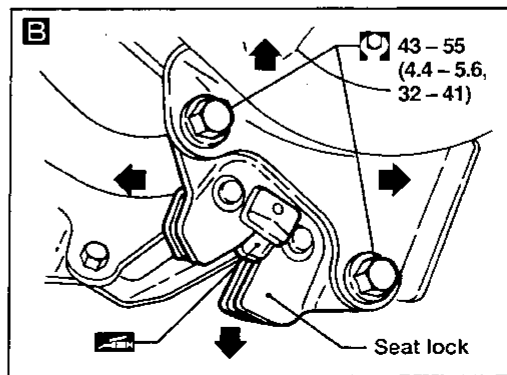
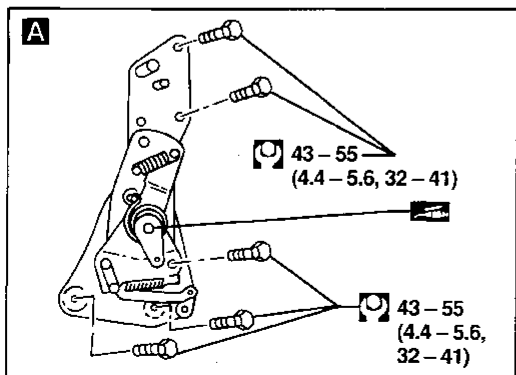
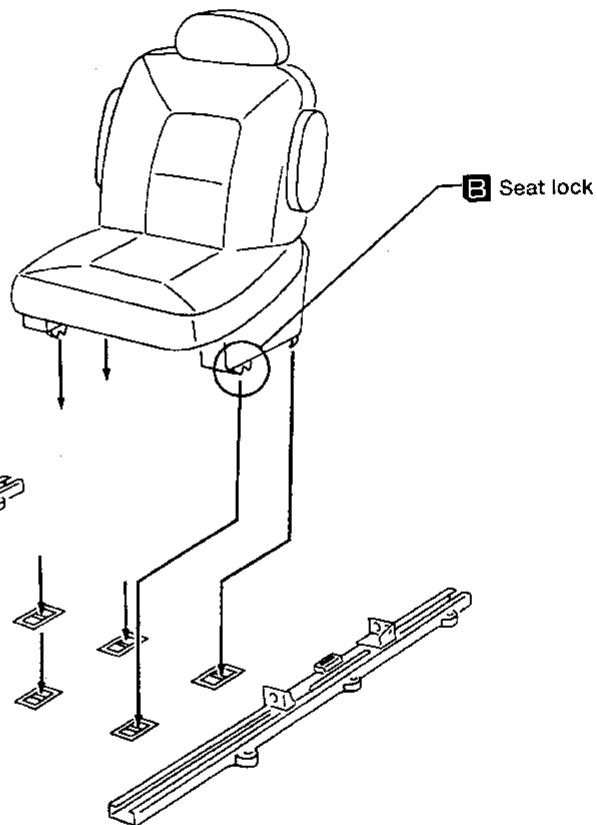
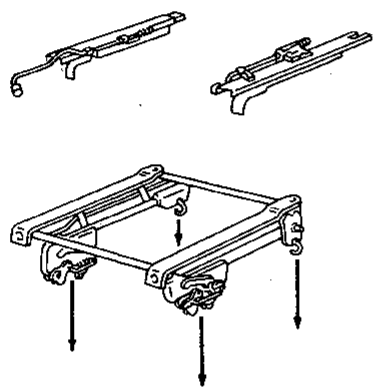
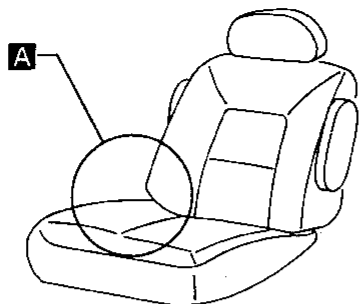

 : N•m (kg-m, ft-lb)

 : Lubricate with grease

**BF-48**

ABF021

# SEAT

## 2nd Seat (Cont'd)

TYPE II

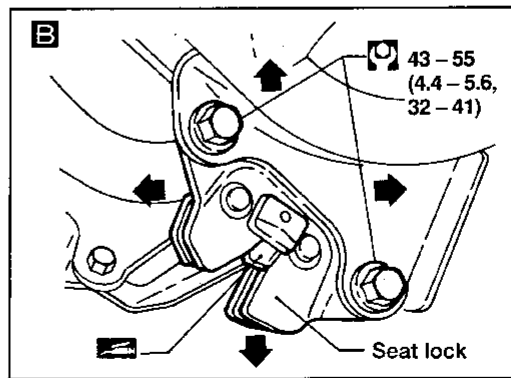
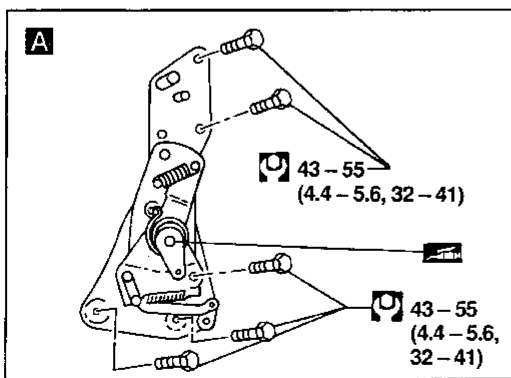
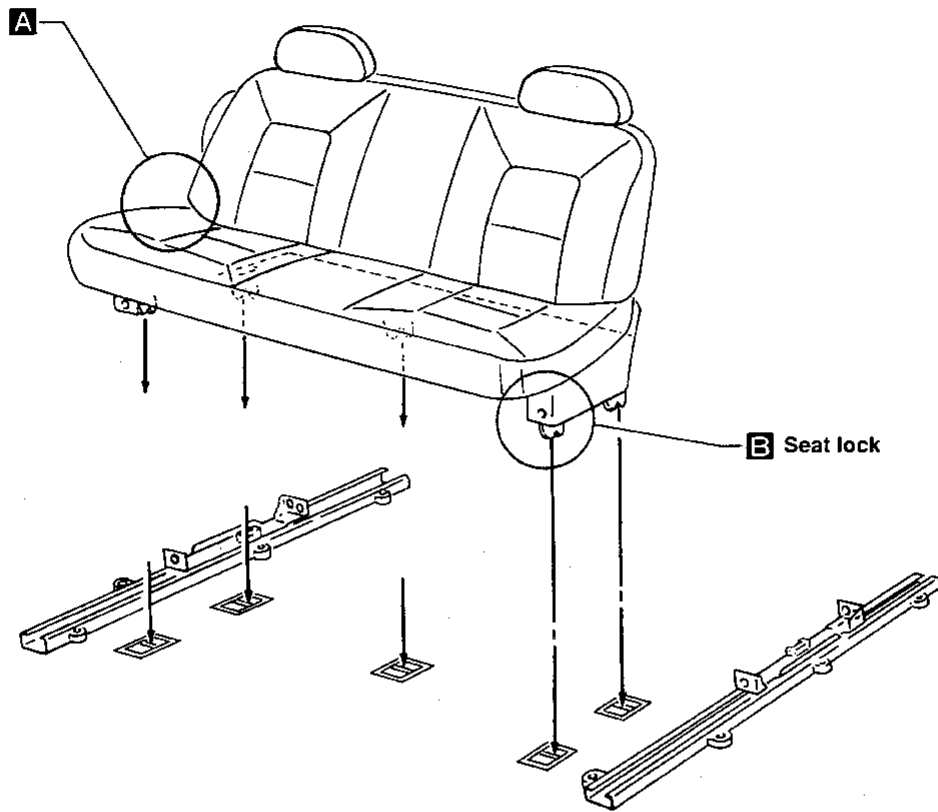

: N•m (kg-m, ft-lb)

: Lubricate with grease

GI

MA

EM

LC

EF &  
EC

FE

AT

FA

RA

BR

ST

**BF**

HA

EL

IDX

# SEAT

## 3rd Seat

### 3rd sliding seat rails — installation

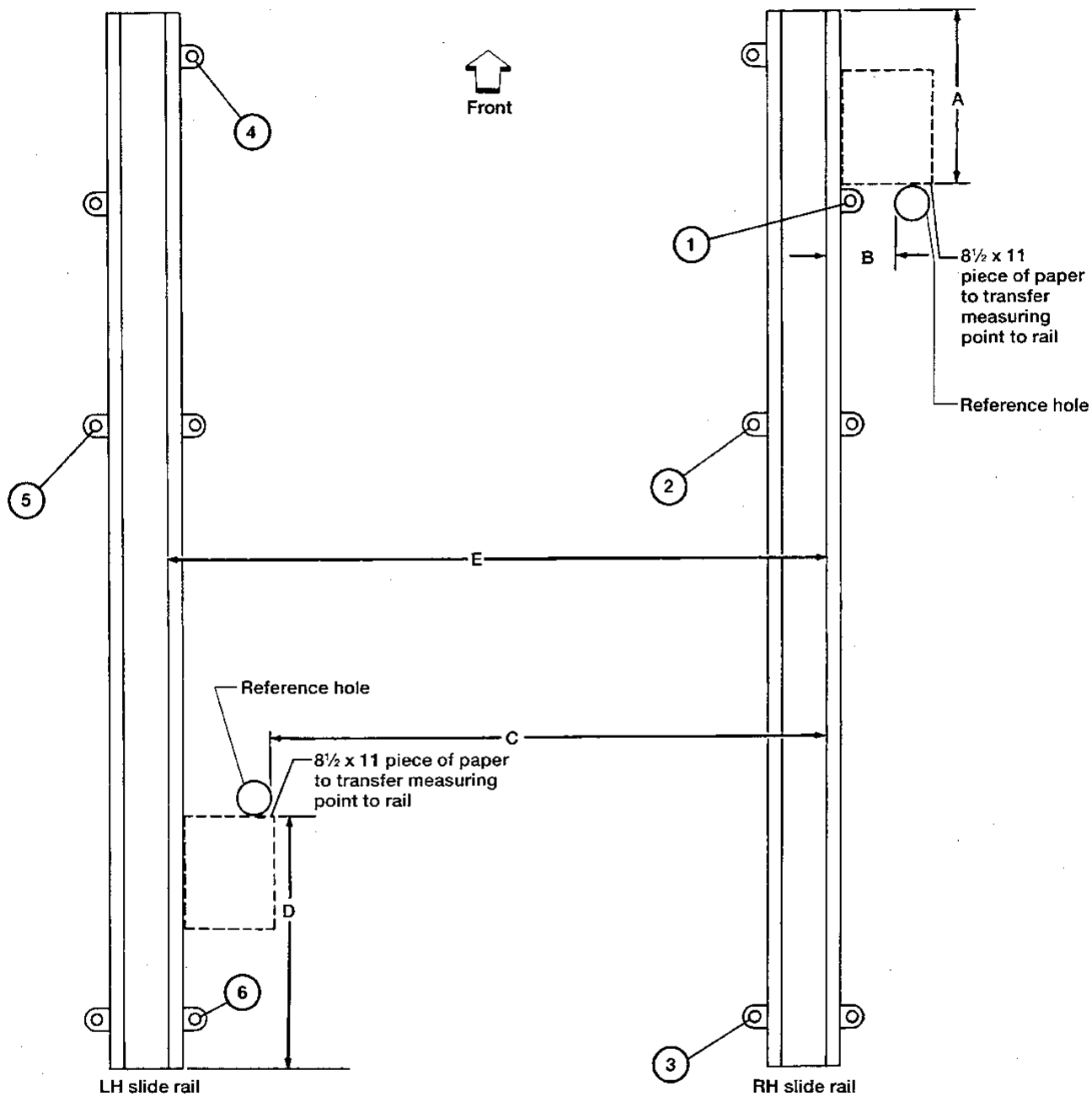

## SEAT

### 3rd Seat (Cont'd) THIRD SLIDING SEAT RAILS

#### Installation for new rails

- The following dimensions may vary by 0.5 mm (0.020 in) to obtain minimum effort to slide the 3rd seat.
  - Use an 8½x11 inch piece of paper to determine distance from reference hole to edge of slide rail.
1. Position the RH slide assembly in the vehicle with the roller in 2nd seating position and loosely install bolts ①, ② and ③.
  2. Measure distance "A".  
**Distance "A":**  
**413.5 mm (16.28 in)**
  3. Measure distance "B" with caliper.  
**Distance "B":**  
**107.00 mm (4.21 in)**
  4. Finger-tighten slide rail bolt ①.
  5. Measure distance "C".  
**Distance "C":**  
**885.50 mm (34.86 in)**
  6. Torque the RH slide rail bolts ①, ② and ③.  
**Torque: 31 - 53 N·m (3.2 - 5.4 kg-m, 23 - 39 ft-lb)**
  7. Check distance "B" and "C" to confirm position, adjust if necessary.
  8. Position the LH slide assembly in the vehicle with roller in 2nd seating position and loosely install bolts ④, ⑤ and ⑥.
  9. Measure distance "D".  
**Distance "D":**  
**561.50 mm (22.11 in)**
  10. Measure distance "E" between the right hand inner edge of each slide rail.  
**Distance "E":**  
**1,110.00 mm (43.70 in)**

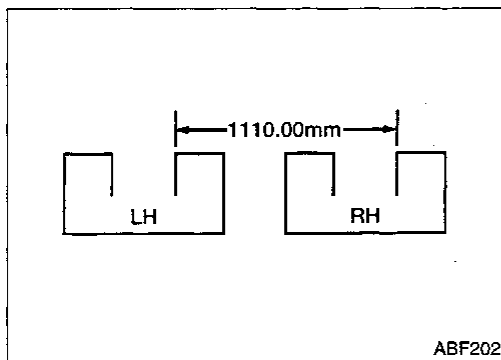

- Measure in two locations where no latch opening exists.

11. Hand-tighten bolts ④, ⑤ and ⑥.
12. Check distance "E" at several points along the slide rails, and adjust **only** the LH slide rail if necessary.
13. Torque the LH slide rail bolts ④, ⑤ and ⑥.  
**Torque: 31 - 53 N·m (3.2 - 5.4 kg-m, 23 - 39 ft-lb)**
14. Install the 3rd seat through side door.
  - Torque front 2 bolts of 3rd seat while it is in 2nd seat position.  
**Torque: 31 - 53 N·m (3.2 - 5.4 kg-m, 23 - 39 ft-lb)**
  - Slide the 3rd seat to full rear position.
  - Hand-start all remaining bolts.

## SEAT

### 3rd Seat (Cont'd)

- Torque rear position bolts, **inner bolts first**.  
☐: **31 - 53 N·m (3.2 - 5.4 kg-m, 23 - 39 ft-lb)**
- 15. Check slide release effort.
- 16. Check slide effort.
- 17. Install all remaining slide rail bolts.
- 18. From front to rear, tighten the slide rail bolts.  
☐: **31 - 53 N·m (3.2 - 5.4 kg-m, 23 - 39 ft-lb)**
- 19. Place the 3rd bench seat in the 2nd seating position and remove the 3rd bench seat.
- 20. Install the floor carpeting.
- 21. Install the 3rd seat through side door.
- **Torque front 2 bolts in 2nd seat position.**  
☐: **31 - 53 N·m (3.2 - 5.4 kg-m, 23 - 39 ft-lb)**
- Slide the 3rd seat to full rear position.
- Hand-start all remaining bolts.
- Torque rear position bolts, **inner bolts first**.  
☐: **31 - 53 N·m (3.2 - 5.4 kg-m, 23 - 39 ft-lb)**
- 22. Check slide release effort. Make adjustments as necessary.
- 23. Check slide effort. Make adjustments as necessary.

### Slide release effort check

1. Remove plastic slide release handle to expose hex shaft.
2. Check slide release effort with torque wrench and hex socket.

#### Release effort:

**2.0 - 9.0 N·m (20 - 92 kg-cm, 17 - 80 in-lb)**

- Torque value is read when the 3rd seat can just begin to move.
- Measure effort at all five latch positions.

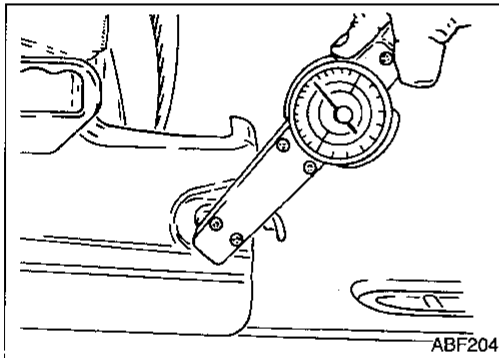

ABF204

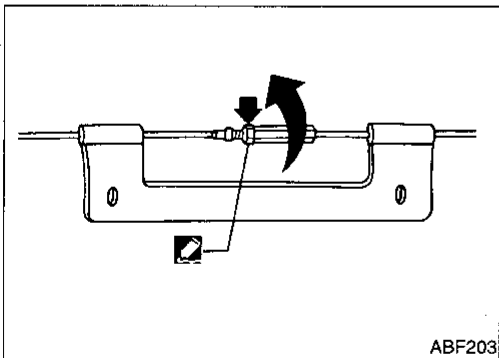

ABF203

3. If release effort is above maximum value, adjust turnbuckle on cable system.
- Loosen locknut on adjuster assembly.
  - Rotate turnbuckle clockwise to tighten the cable and reduce slide release effort.
  - Tighten the locknut and apply locking sealant.

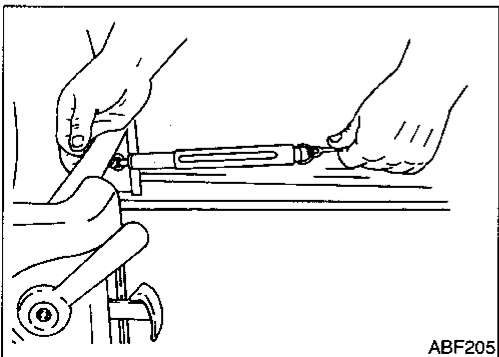

ABF205

### Slide effort check

- Check slide effort.  
**Maximum starting effort:**  
**118 N (12 kg, 26 lb)**  
**(measured at center of the 3rd seat with slide release handle fully up)**
- Measure rearward starting effort at front four latch positions with a force gauge (spring scale).
- After starting efforts have been taken, slide the 3rd seat five times the full length of the slide rails. If at anytime the seat binds, stop and take the starting effort at that location.

## SEAT

### 3rd Seat (Cont'd)

- Adjust LH slide rail side-to-side for excessive slide effort.
- If force is too high, adjust only LH slide rail until force is correct.

GI

MA

EM

LC

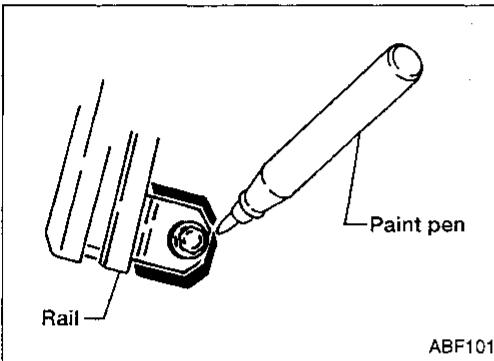

### Removal and installation for the same rails

1. Mark the rails' positions on the floor panel at the points of bolts ① to ⑥ before removing rails.
2. Loosen bolts and remove rails.
3. Install rails so that they will align with the marks made during step 1.

Torque bolts ① to ⑥.

**Ⓜ: 31 - 53 N·m (3.2 - 5.4 kg-m, 23 - 39 ft-lb)**

4. Follow the procedures beginning with step 14 in "Installation for new rails", then perform "Slide release effort check" and "Slide effort check".

EF &

EC

FE

AT

FA

RA

BR

ST

BF

HA

EL

IDX

# SEAT

## 3rd Seat (Cont'd)

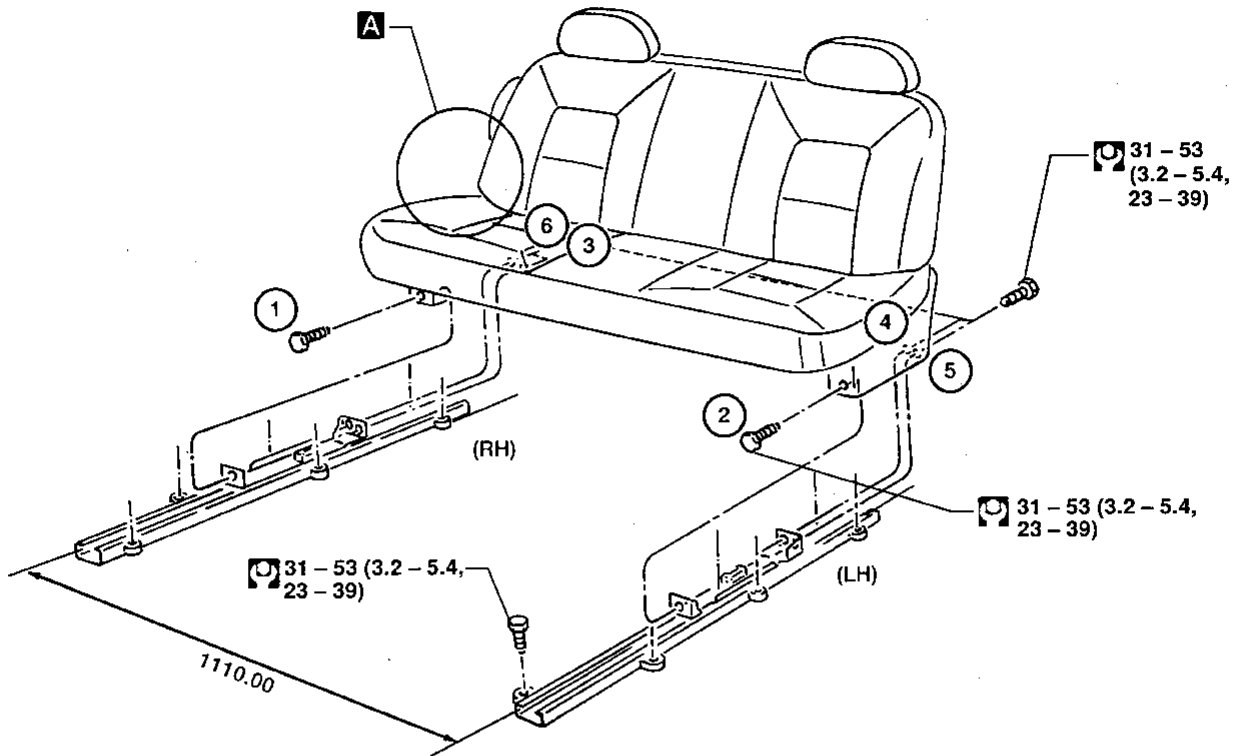

Important: Follow installation sequence and procedure.

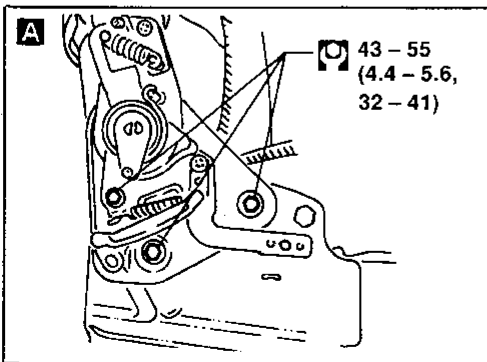

 : N·m (kg·m, ft·lb)



NOTE

GI

MA

EM

LC

EF &  
EC

FE

AT

FA

RA

BR

ST

**BF**

HA

EL

IDX

# AUTOMATIC SEAT BELT SYSTEM

## Unit Location

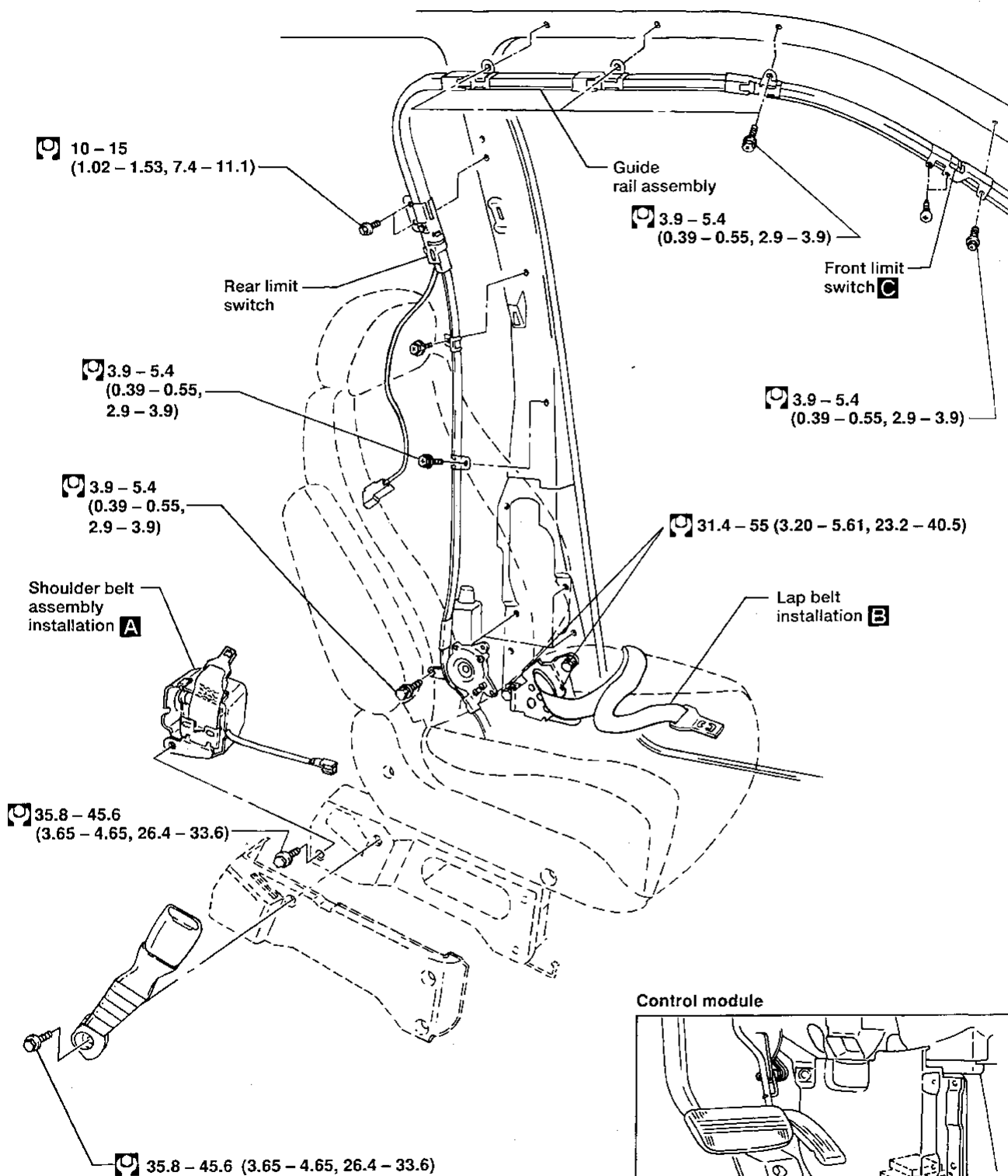

### Control module

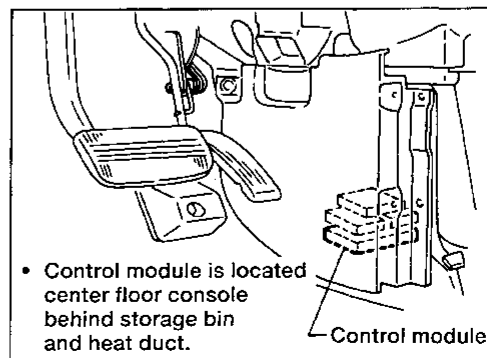

: N·m (kg-m, ft-lb)

ABF256

# AUTOMATIC SEAT BELT SYSTEM

GI

MA

EM

LC

EF &  
EC

FE

AT

FA

RA

BR

ST

BF

HA

EL

IDX

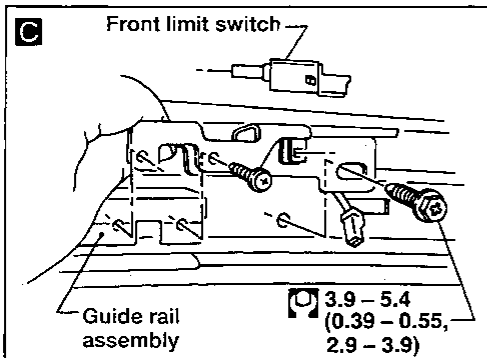
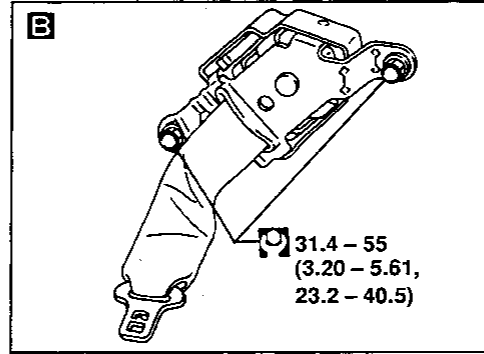
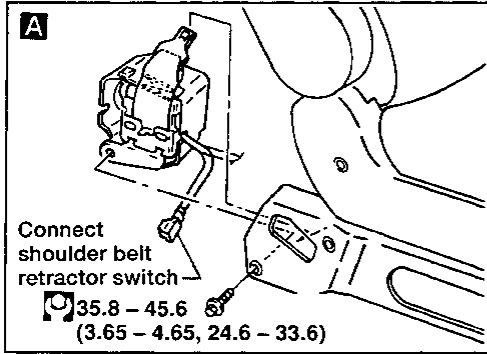

: N·m (kg-m, ft-lb)

ABF257

## Removal and Installation

### SHOULDER BELT BUCKLE DRIVE MOTOR

- When removing drive motor, remove terminals from rear limit switch and motor assembly connector.

- Note the wire color and terminal number for the drive motor terminals.
- When installing, the drive motor terminals must be inserted in the connector as shown at left.

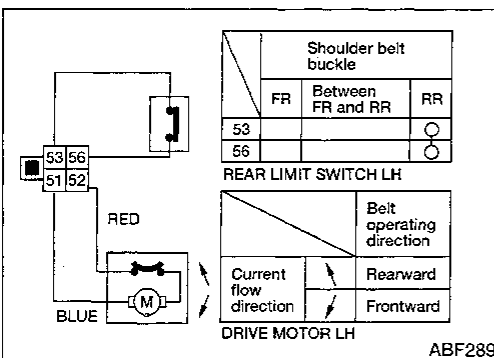
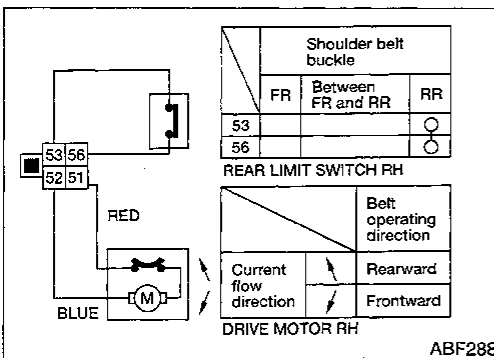

# AUTOMATIC SEAT BELT SYSTEM

## Wiring Diagram -S/BELT-

**BF-S/BELT-01**

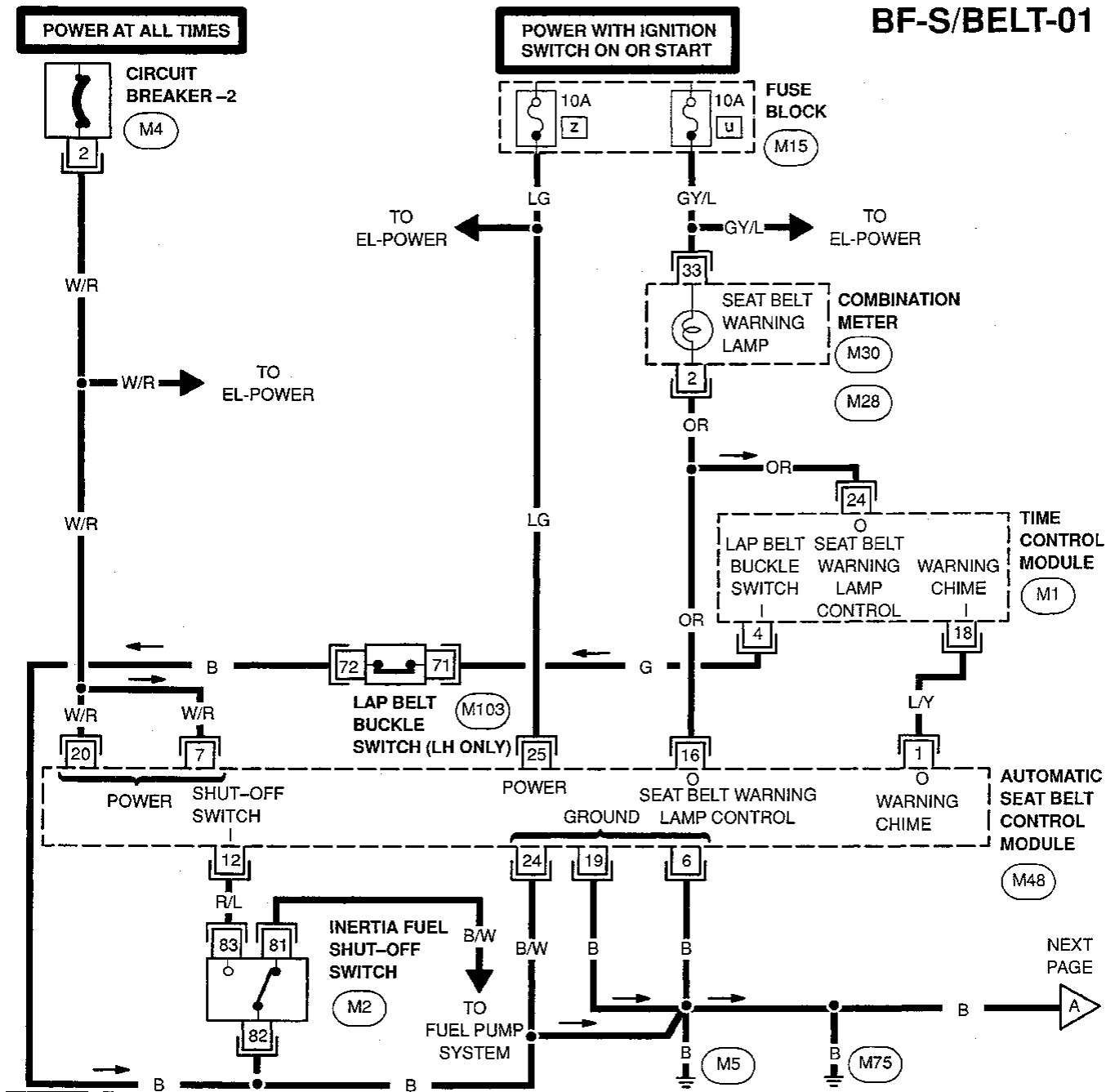

NEXT PAGE  
A

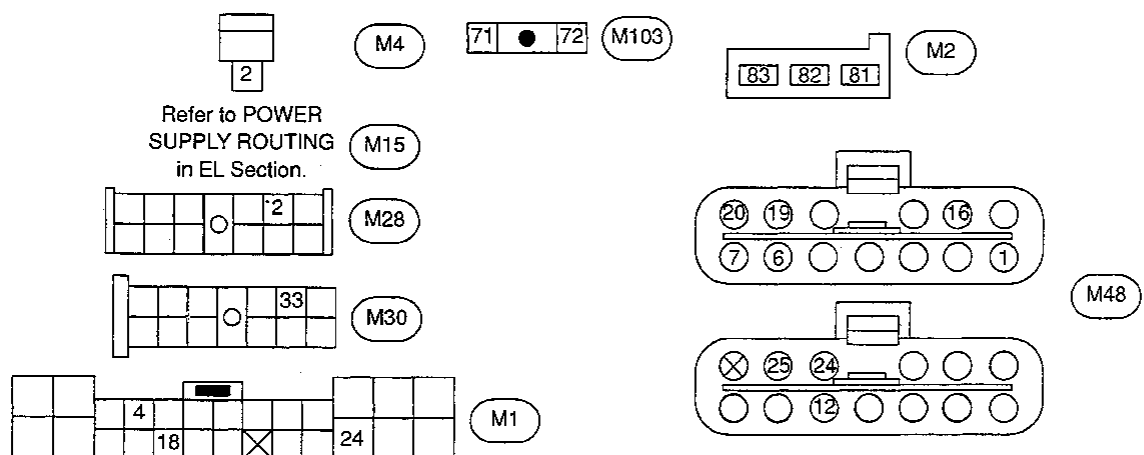

Refer to POWER SUPPLY ROUTING in EL Section.

# AUTOMATIC SEAT BELT SYSTEM

## Wiring Diagram -S/BELT- (Cont'd)

**BF-S/BELT-02**

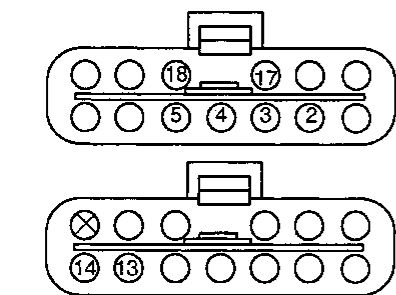
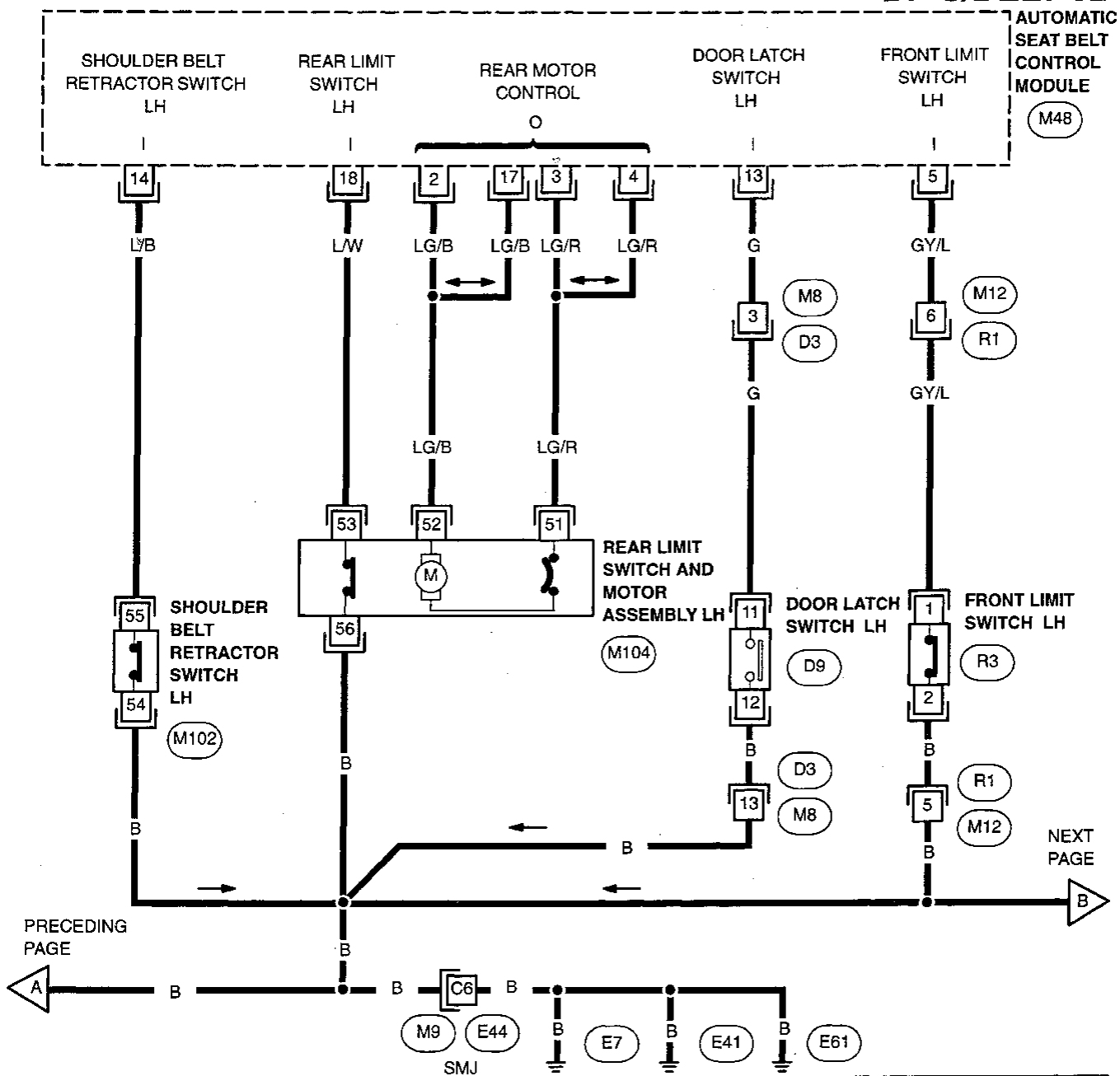

M48

Refer to Foldout Page in EL Section for details.



M102



M104



D9



R3

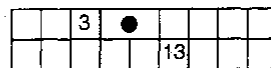

M8

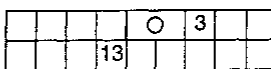

D3



M12

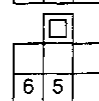

R1

ABF223-B

# AUTOMATIC SEAT BELT SYSTEM

## Wiring Diagram -S/BELT- (Cont'd)

### BF-S/BELT-03

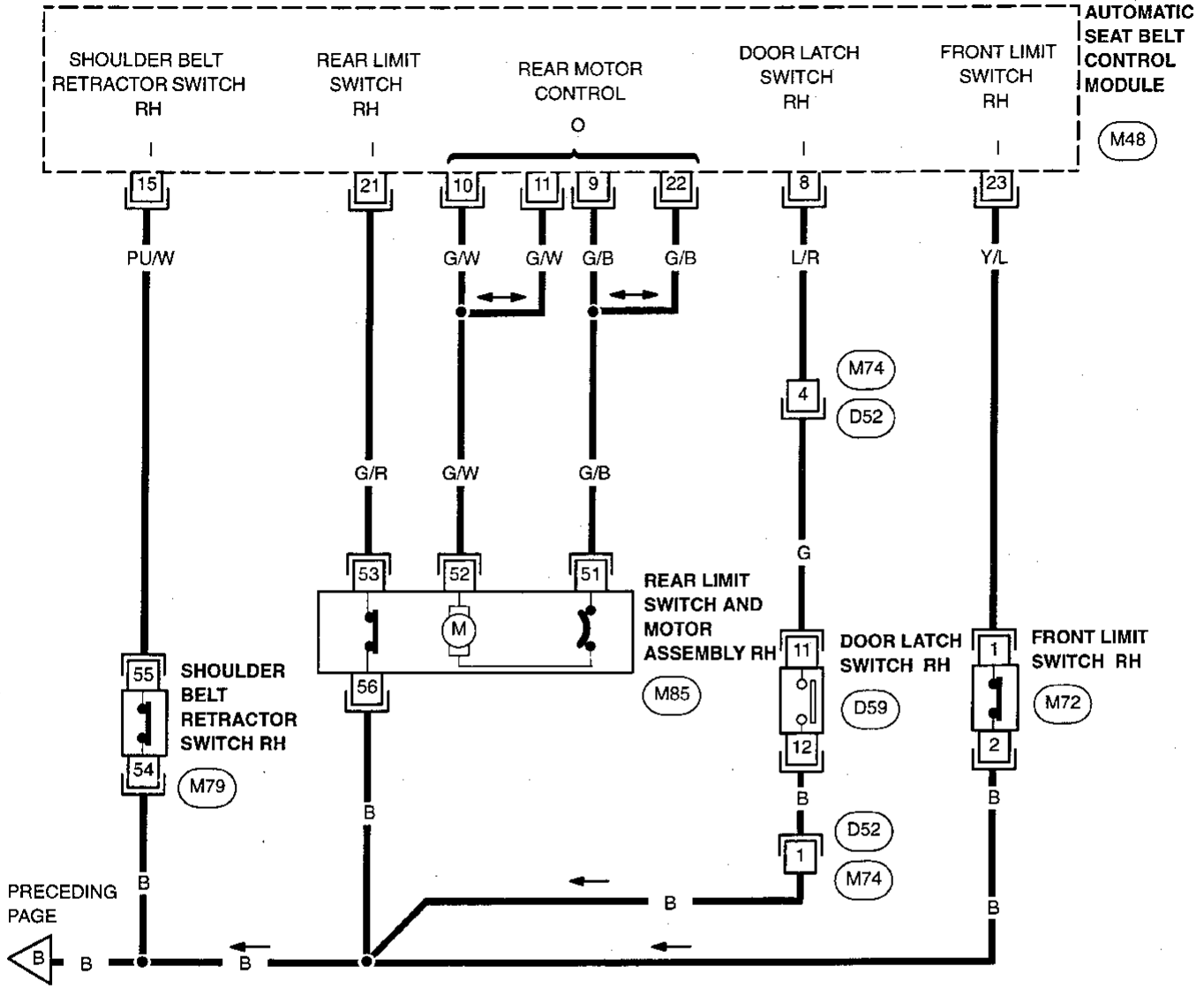

PRECEDING PAGE

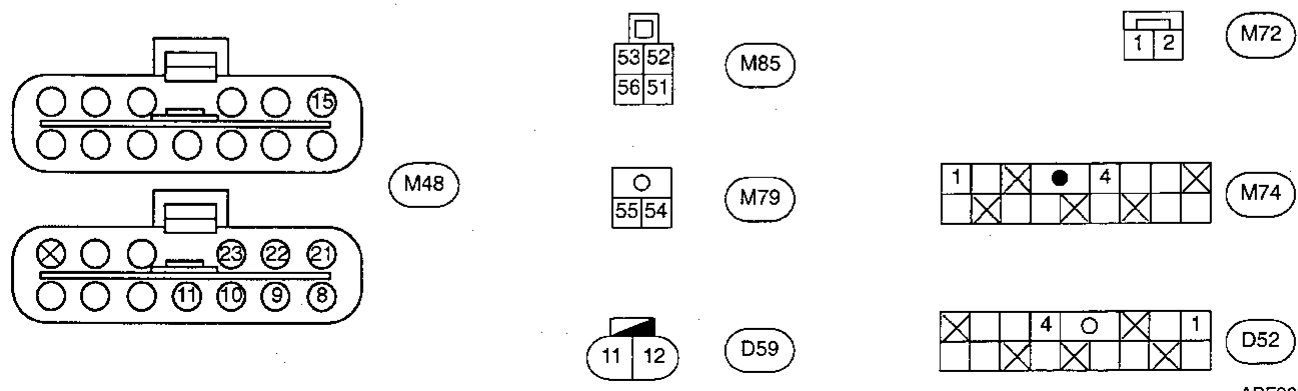

ABF223-C

# AUTOMATIC SEAT BELT SYSTEM

## Description

### FUNCTION

Shoulder belt buckle is mainly operated while ignition switch is "ON".

Condition (A): Ignition switch is "ON".

When door is opened, shoulder belt buckle is moved frontward and when door is closed, buckle is moved rearward.

Condition (B): Ignition switch is "OFF".

When door is opened, shoulder belt buckle is moved frontward. When the door is closed, buckle will remain in this position.

(Voltage of output signal is approximate value.)

Input signal	Ignition switch	OFF	OFF	ON	ON	ON	ON	ON	ON	OFF	OFF	OFF	OFF
	Door latch switch	OFF	ON	OFF	OFF	OFF	ON	ON	ON	OFF	ON	ON	OFF
	Front limit switch	ON	ON	ON	OFF	OFF	OFF	OFF	ON	OFF	OFF	OFF	OFF
	Rear limit switch	OFF	OFF	OFF	OFF	ON	ON	OFF	OFF	ON	ON	OFF	OFF
Output signal	Drive motor power source for frontward operation	0V	0V	0V	0V	0V	12V	12V	0V	0V	12V	12V	0V
	Drive motor power source for rearward operation	0V	0V	12V	12V	0V	0V	0V	0V	0V	0V	0V	0V
Shoulder belt buckle	Function	Stop	Stop	Start to move	Moving	Stop	Start to move	Moving	Stop	Stop	Start to move	Moving	Stop
	Position	Front	Front	Front	Between Front & Rear	Rear	Rear	Between Front & Rear	Front	Rear	Rear	Between Front & Rear	Between Front & Rear

### REAR LOCK (Inertia fuel shutoff switch "ON")

If inertia fuel shutoff switch is triggered, shoulder belt buckle will remain in rear position.

# AUTOMATIC SEAT BELT SYSTEM

## Description (Cont'd)

### WARNING

Priority	Warning item	Ignition switch	Indication of warning (Indicating time is approximately value.)	
1	Shoulder belt buckles are not at rear lock position. Shoulder belts and driver's lap belt fastened.	OFF → ON	Lamp	
			Chime	
			Anchor	
2	Shoulder belts are not fastened.	OFF → ON	Lamp	
			Chime	
		ON	Lamp	
			Chime	
			Belt	
3	Driver's lap belt is not fastened.	OFF → ON	Lamp	
			Chime	
			Lamp	
			Chime	
			Belt	
4	Normal (All belts are fastened and shoulder belt buckles are in rear lock position.)	OFF → ON	Lamp	
			Chime	



# AUTOMATIC SEAT BELT SYSTEM — Trouble Diagnoses

---

## IMPORTANT

---

Since left and right component parts are basically the same, harness layout and methods for electrical components inspection are shown for one side only.

Although methods for checking component parts on both sides are described in the flow chart to make it easier to troubleshoot, apply checking procedures to either side that has malfunction during trouble diagnoses. For those methods enclosed by double rectangulars, however, component parts on both sides must be checked as problems occurring on either side cannot be easily determined by a symptom.

GI

MA

EM

LC

EF &  
EC

FE

AT

FA

RA

BR

ST

**BF**

HA

EL

IDX

# AUTOMATIC SEAT BELT SYSTEM — Trouble Diagnoses

## Symptom Chart

Procedure	Reference page	SYMPTOM						
Electrical Components Inspection	BF-89	Motor	○	○				
	BF-89	Shoulder belt retractor switch	○				○	
	BF-89	Door latch switch	○		○	○		
	BF-89	Rear limit switch	○	○	○		○	
	BF-89	Front limit switch	○	○		○		
	BF-90	Lap belt buckle switch	○				○	
	BF-89	Motor	○	○				
	BF-89	Shoulder belt retractor switch	○				○	
	BF-89	Door latch switch	○		○	○		
	BF-89	Rear limit switch	○	○	○		○	
	BF-89	Front limit switch	○	○		○		
	—	Warning chime	○				○	
	—	Warning lamp	○				○	
	Diagnostic Procedure	BF-88	Procedure 10				○	
		BF-87	Procedure 9			○		
BF-86		Procedure 8					○	
BF-85		Procedure 7					○	
BF-84		Procedure 6					○	
BF-82		Procedure 5					○	
BF-80		Procedure 4	○	○	○		○	
BF-78		Procedure 3	○	○		○		
BF-76		Procedure 2			○	○		
BF-73		Procedure 1	○	○				
Main Power Supply and Ground Circuit Check	BF-69	Procedure 2		○				
	BF-69	Procedure 1	○					
Preliminary Check	BF-67	Procedure 2					○	
	BF-65	Procedure 1		○	○	○		
Procedure	Reference page	<p>SYMPTOM</p> <p>No operation has been made. (No warning indicated and no buckle movement performed)</p> <p>Shoulder belt buckle in LH or RH side does not move.</p> <p>Shoulder belt buckle moves frontwards only. (not rearwards)</p> <p>Shoulder belt buckle moves rearwards only. (not frontwards)</p> <p>Warnings indicate incorrectly or do not function.</p>						

## Preliminary Check

### PROCEDURE 1

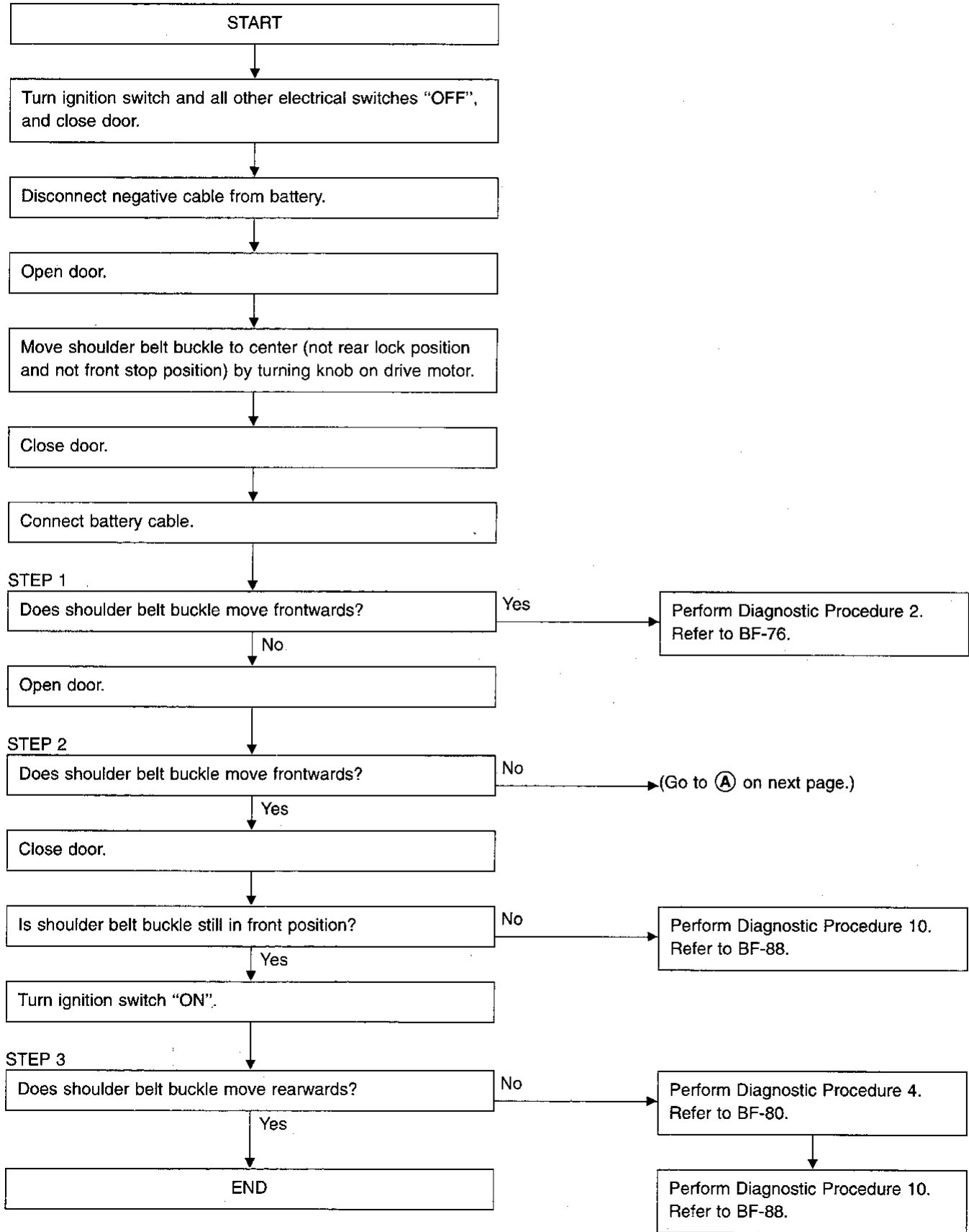

GI  
 MA  
 EM  
 LC  
 EF &  
 EC  
 FE  
 AT  
 FA  
 RA  
 BR  
 ST  
**BF**  
 HA  
 EL  
 IDX

# AUTOMATIC SEAT BELT SYSTEM — Trouble Diagnoses

## Preliminary Check (Cont'd)

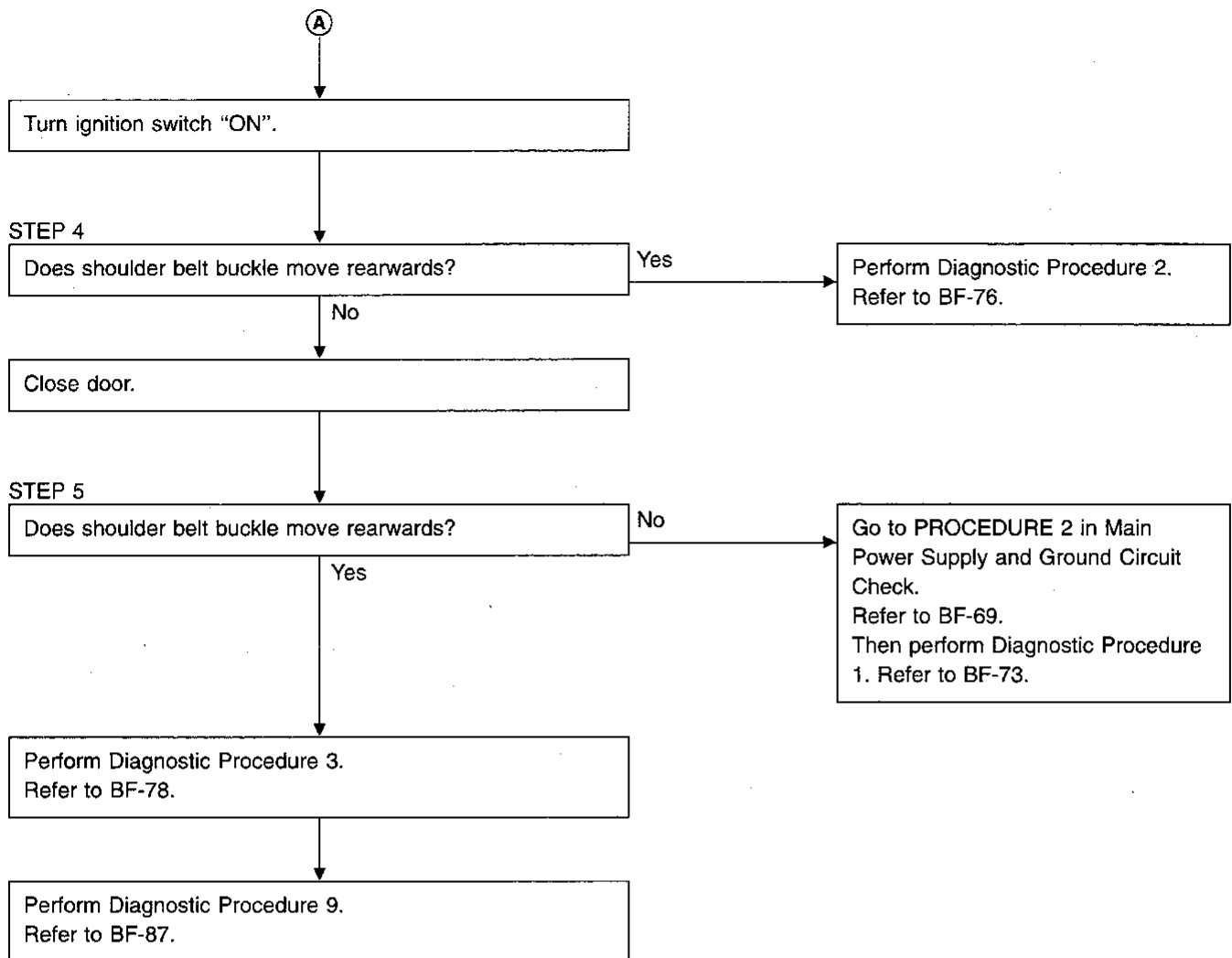

# AUTOMATIC SEAT BELT SYSTEM — Trouble Diagnoses

## Preliminary Check (Cont'd)

### PROCEDURE 2

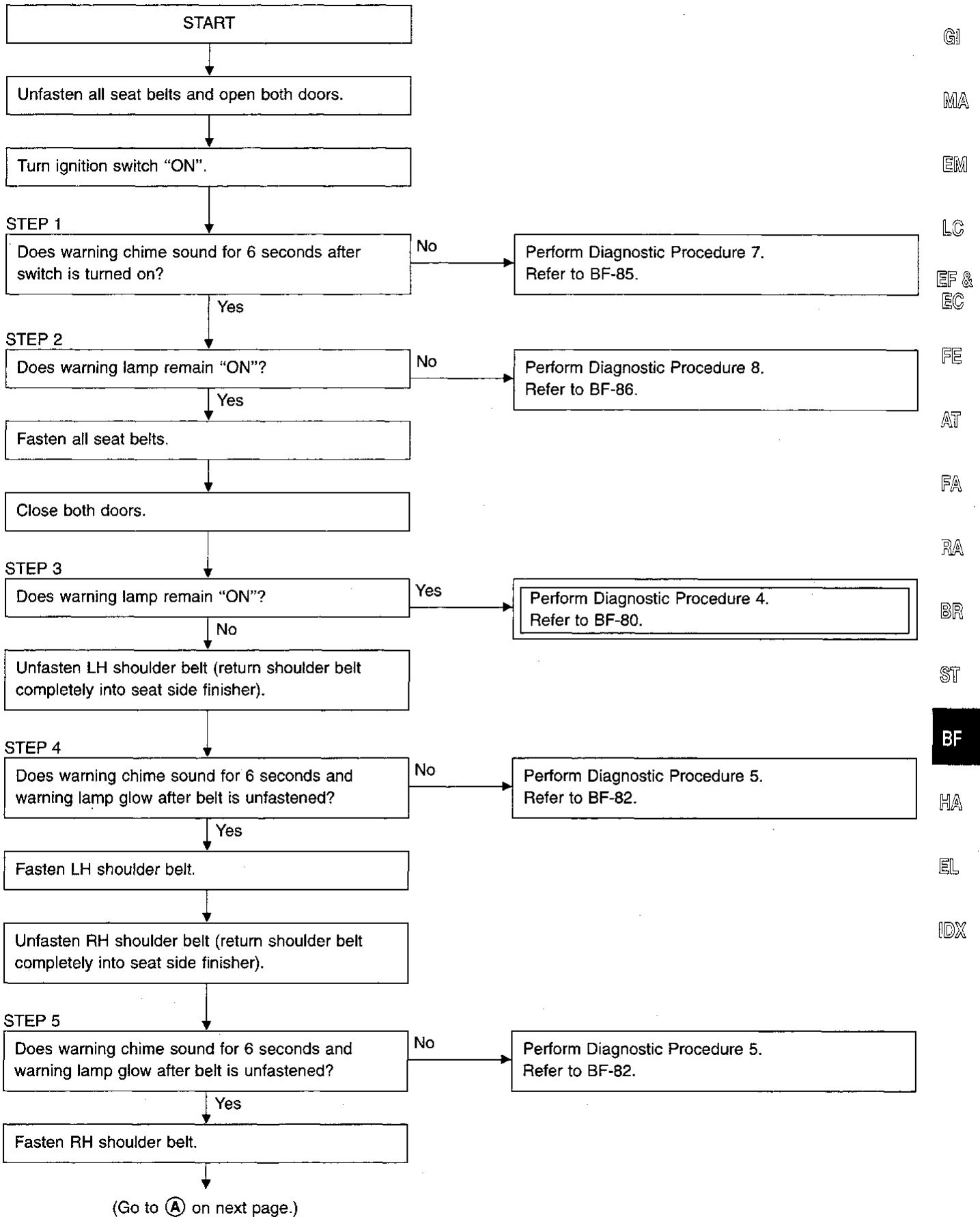

GI

MA

EM

LC

EF &amp;

EC

FE

AT

FA

RA

BR

ST

BF

HA

EL

IDX

# AUTOMATIC SEAT BELT SYSTEM — Trouble Diagnoses

## Preliminary Check (Cont'd)

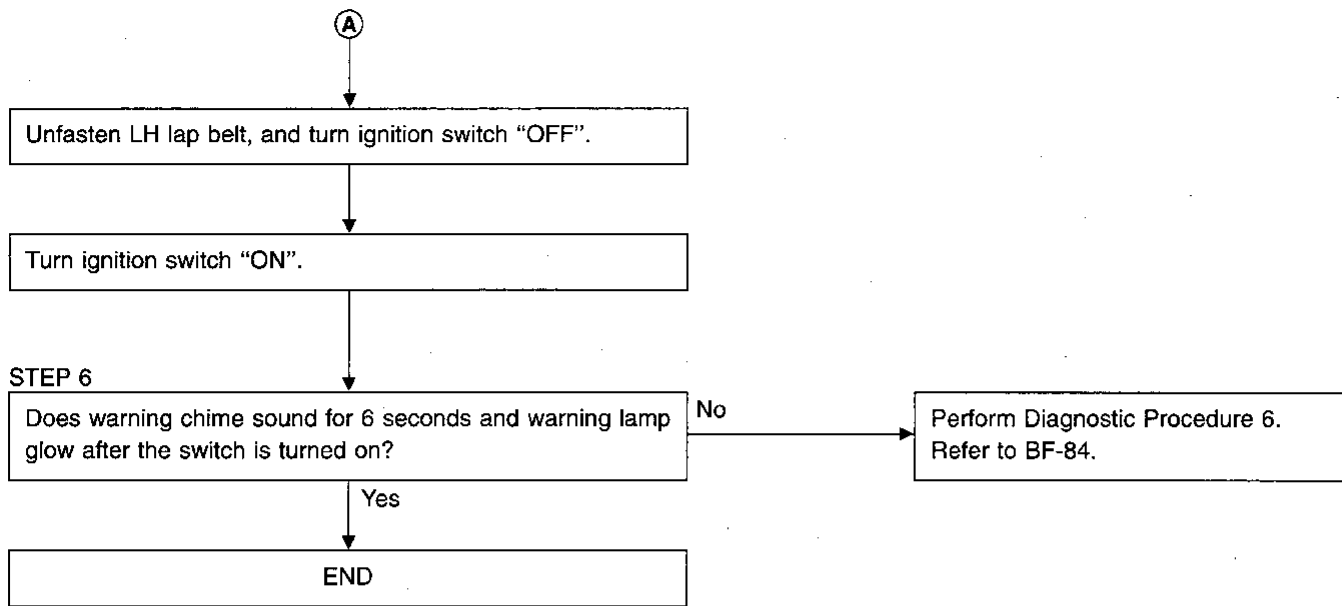

# AUTOMATIC SEAT BELT SYSTEM — Trouble Diagnoses

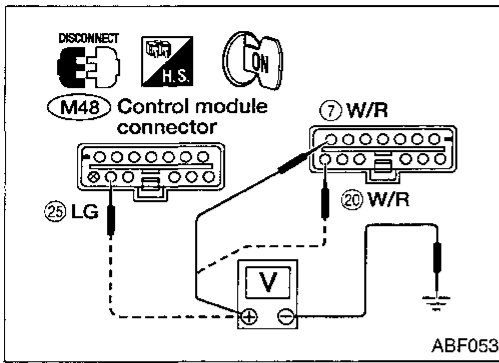

## Main Power Supply and Ground Circuit Check

### PROCEDURE 1

#### Main power supply

Terminals	Battery positive voltage existence condition	
	Ignition switch "ON"	Other than ignition switch "ON"
⑦ - Ground	Yes	Yes
⑳ - Ground	Yes	Yes
㉕ - Ground	Yes	No

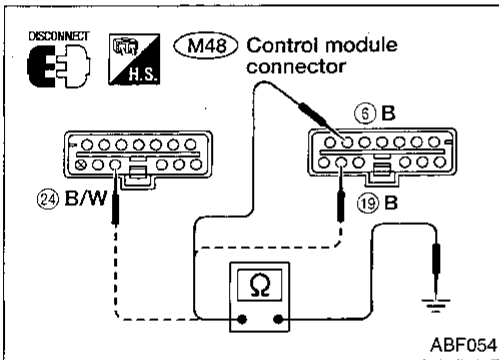

#### Ground circuit

Terminals	Continuity
⑥ - Ground	Yes
⑱ - Ground	Yes
㉔ - Ground	Yes

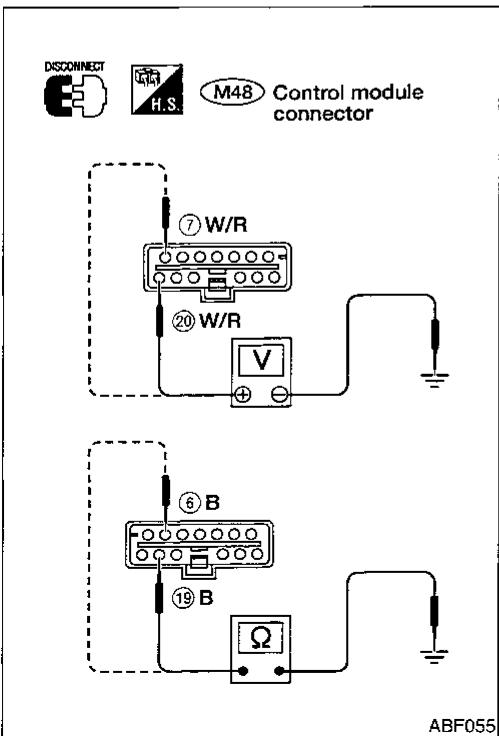

### PROCEDURE 2

#### Power supply for drive motor

Terminals	Battery positive voltage existence
⑦ - Ground	Yes
⑳ - Ground	Yes

#### Ground circuit for drive motor

Terminals	Continuity
⑥ - Ground	Yes
⑱ - Ground	Yes

GI  
MA  
EM  
LC  
EF &  
EC  
FE  
AT  
FA  
RA  
BR  
ST  
BF  
HA  
EL  
IDX

## Harness Layout

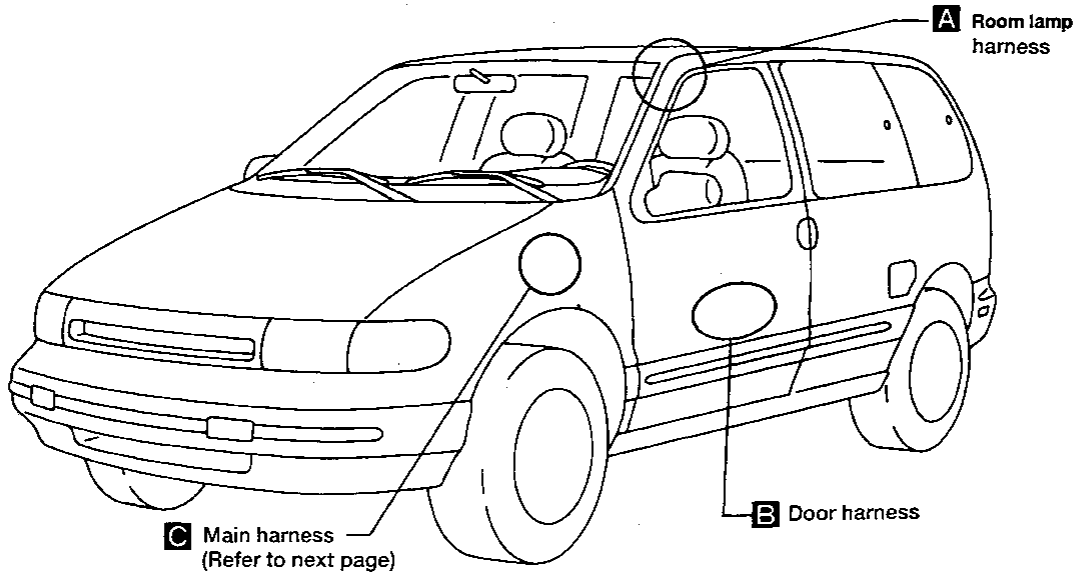

**A**

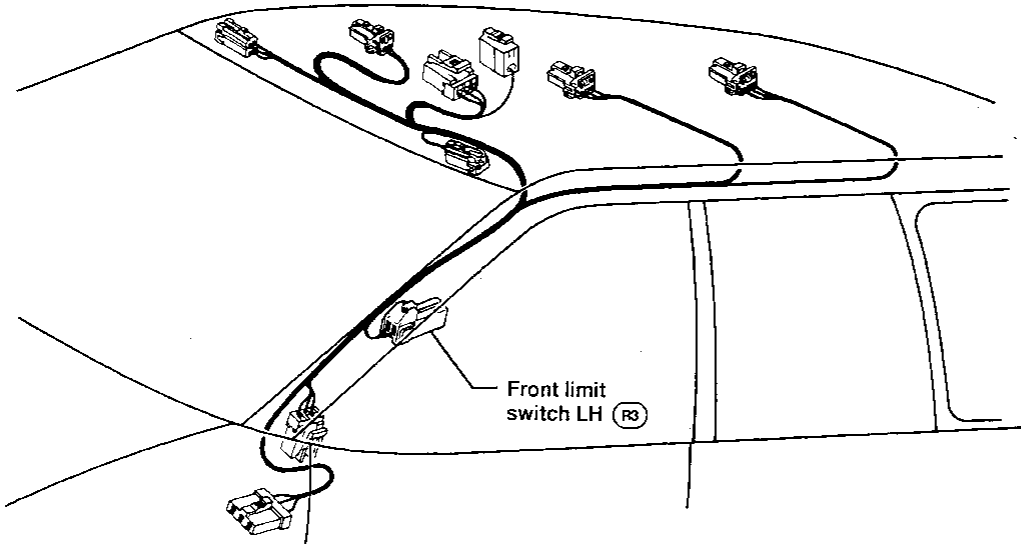

**B**

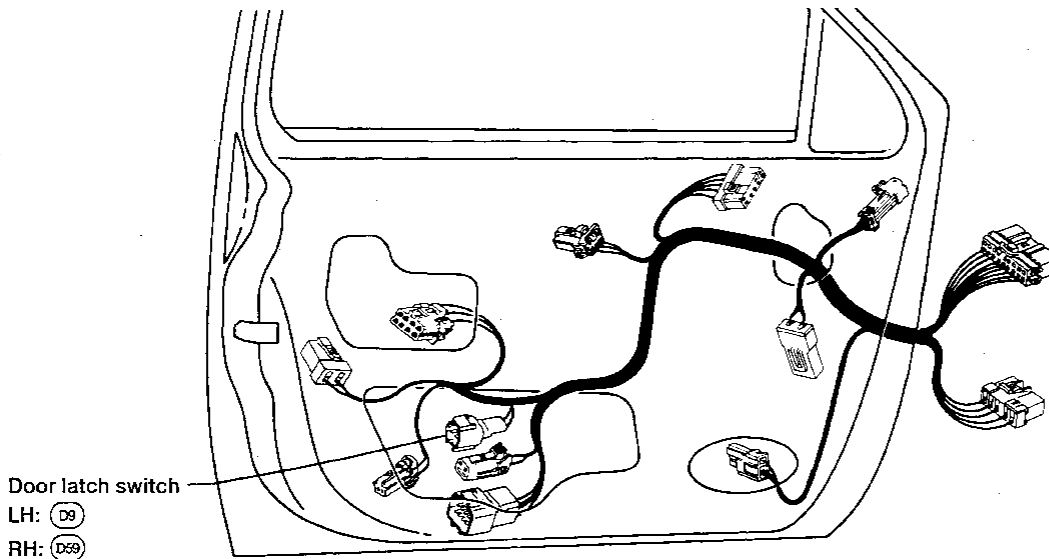

**BF-70**

ABF280



# AUTOMATIC SEAT BELT SYSTEM — Trouble Diagnoses

## Harness Layout (Cont'd)

C

Body ground

Body ground

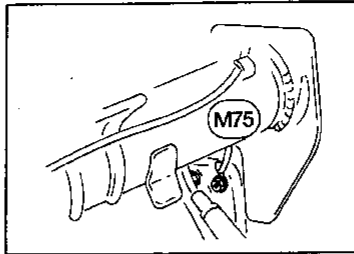
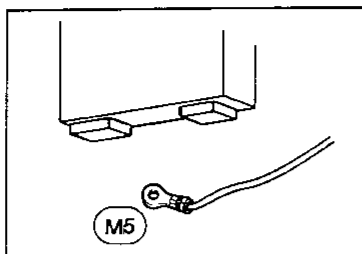

Front limit switch RH (M72)

GI

MA

EM

LC

EF & EC

FE

AT

FA

RA

BR

ST

BF

HA

EL

IDX

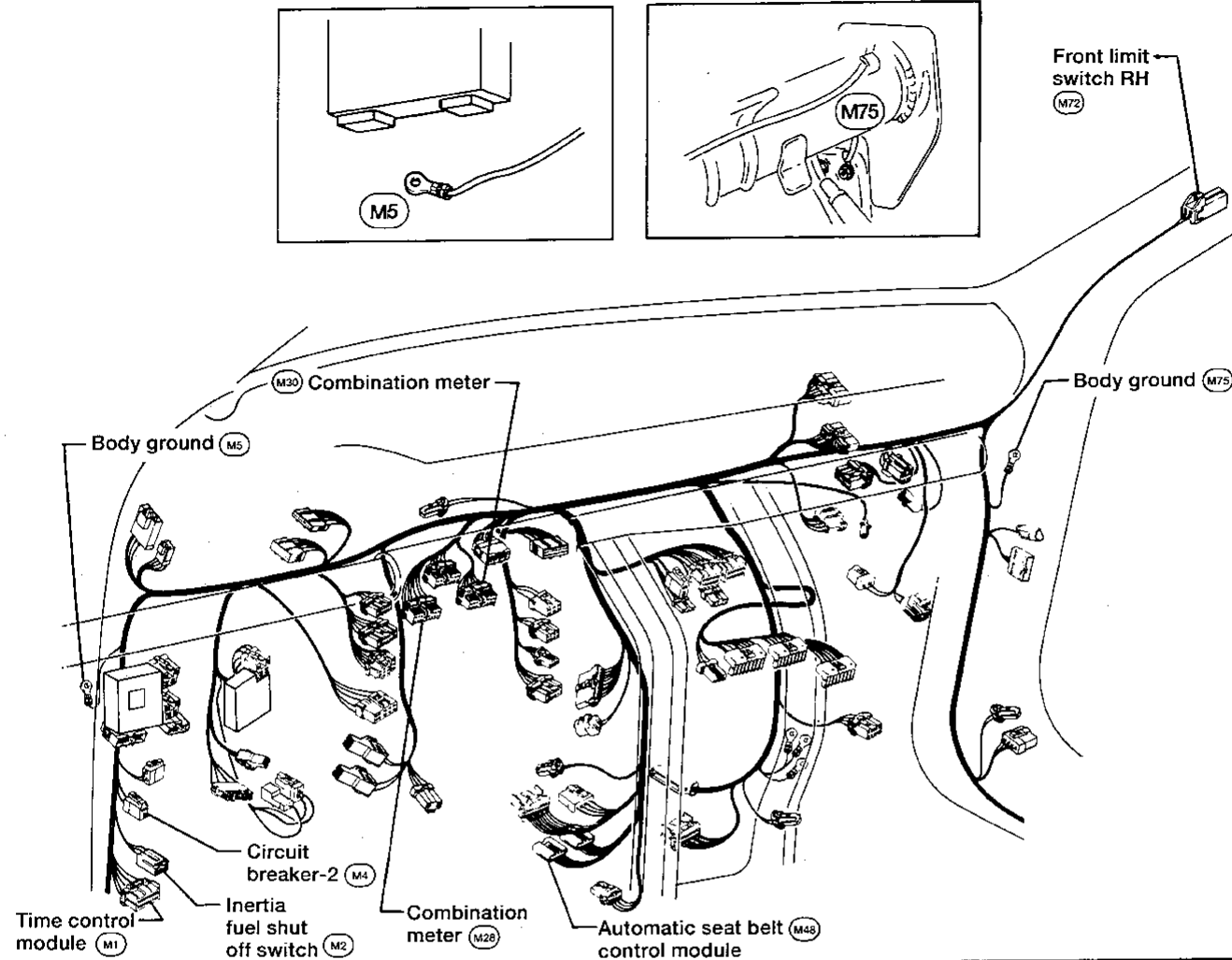

Shoulder belt retractor switch LH (M102)

Shoulder belt retractor switch RH (M79)

Rear limit switch and drive motor RH (M85)

Rear limit switch and drive motor LH (M104)

Lap belt buckle switch (M103)

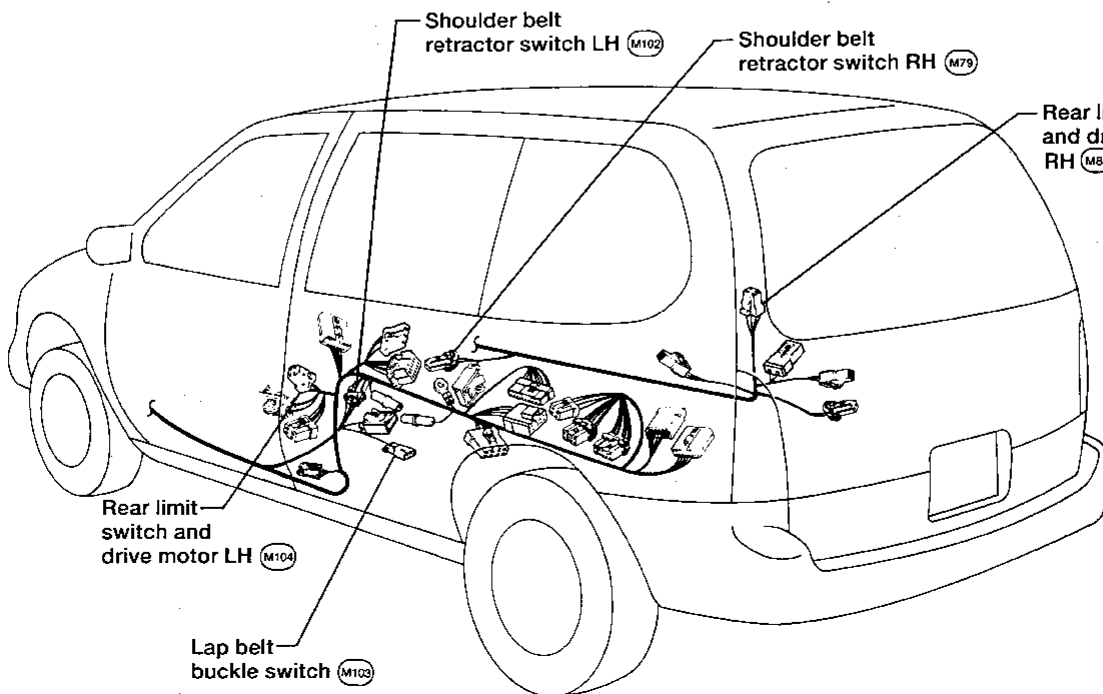

BF-71

ABF279

# AUTOMATIC SEAT BELT SYSTEM — Trouble Diagnoses

## Circuit Diagram for Quick Pinpoint Check

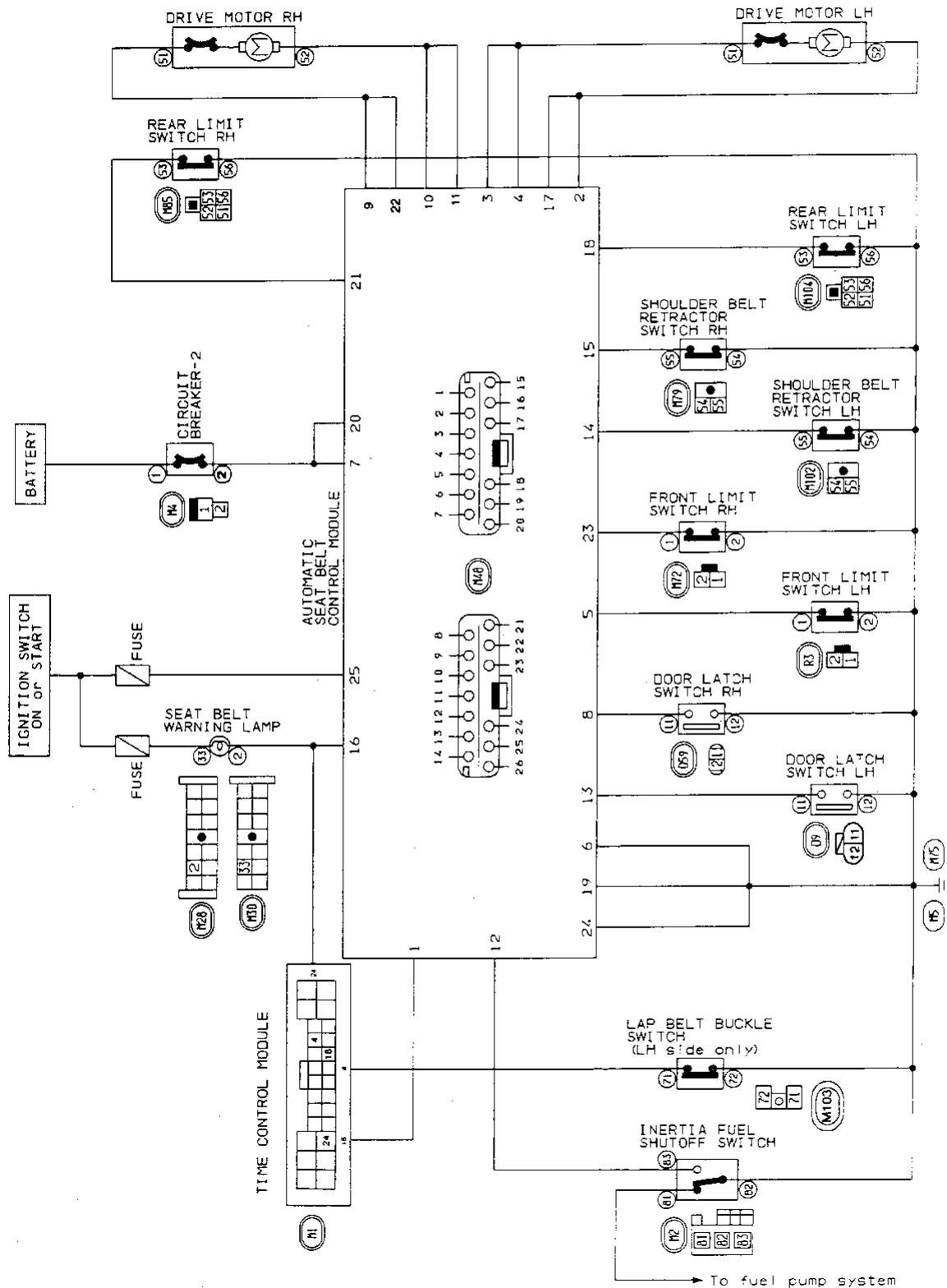

# AUTOMATIC SEAT BELT SYSTEM — Trouble Diagnoses

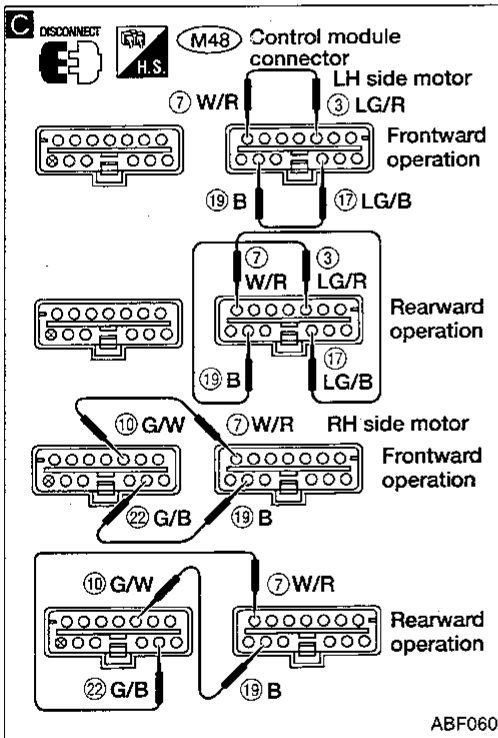
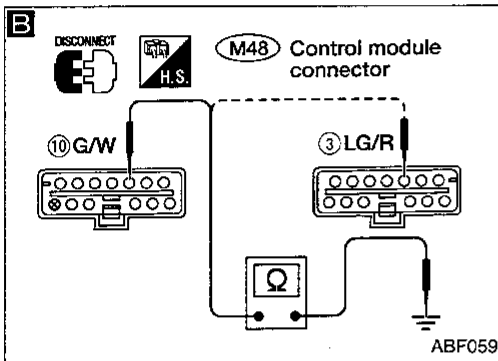
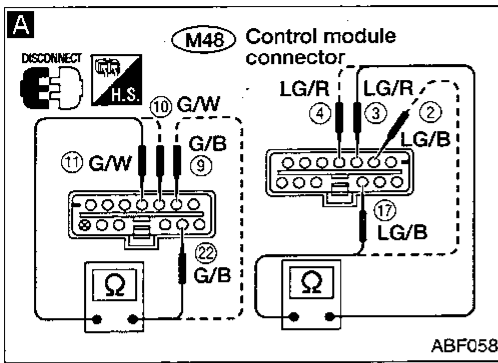

## Diagnostic Procedure 1

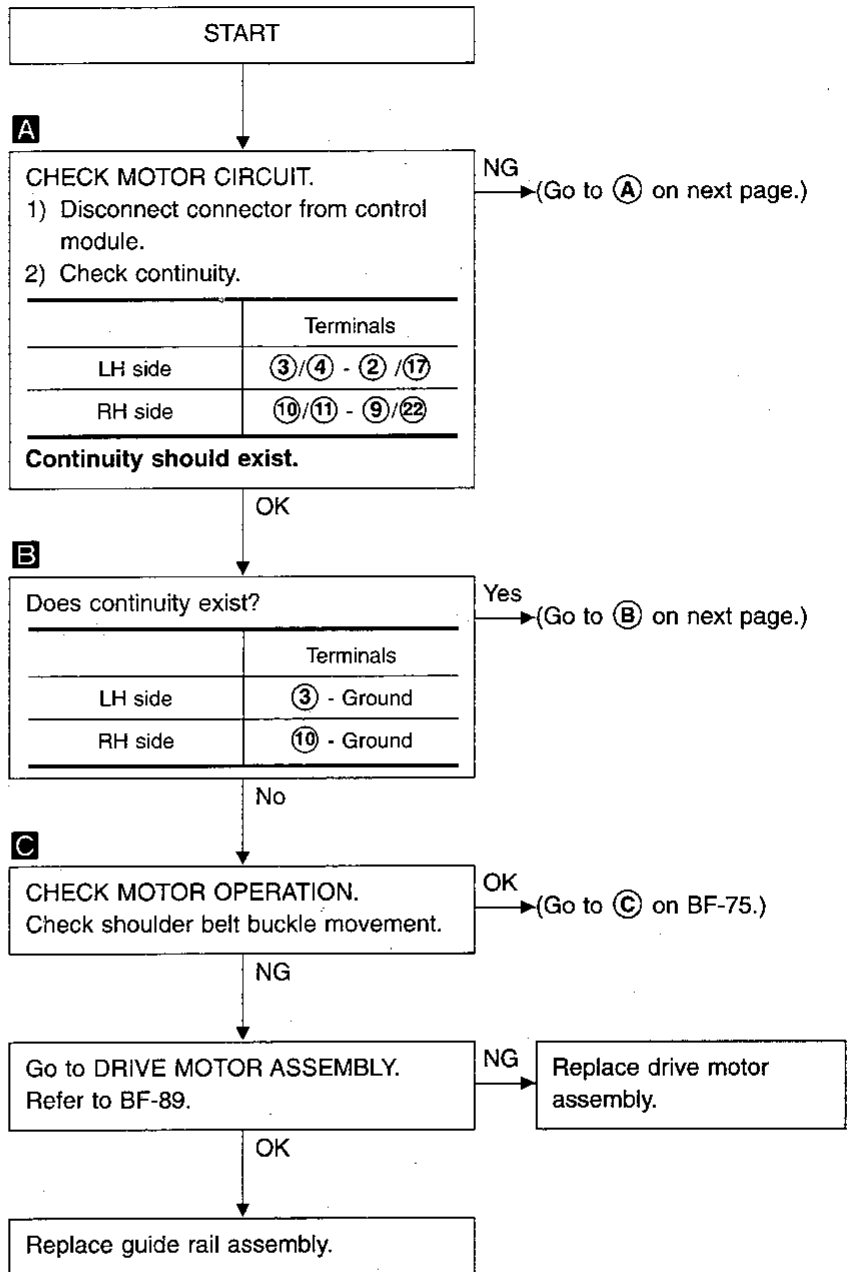

GI  
MA  
EM  
LC  
EF & EC  
FE  
AT  
FA  
RA  
BR  
ST  
BF  
HA  
EL  
IDX

# AUTOMATIC SEAT BELT SYSTEM — Trouble Diagnoses

## Diagnostic Procedure 1 (Cont'd)

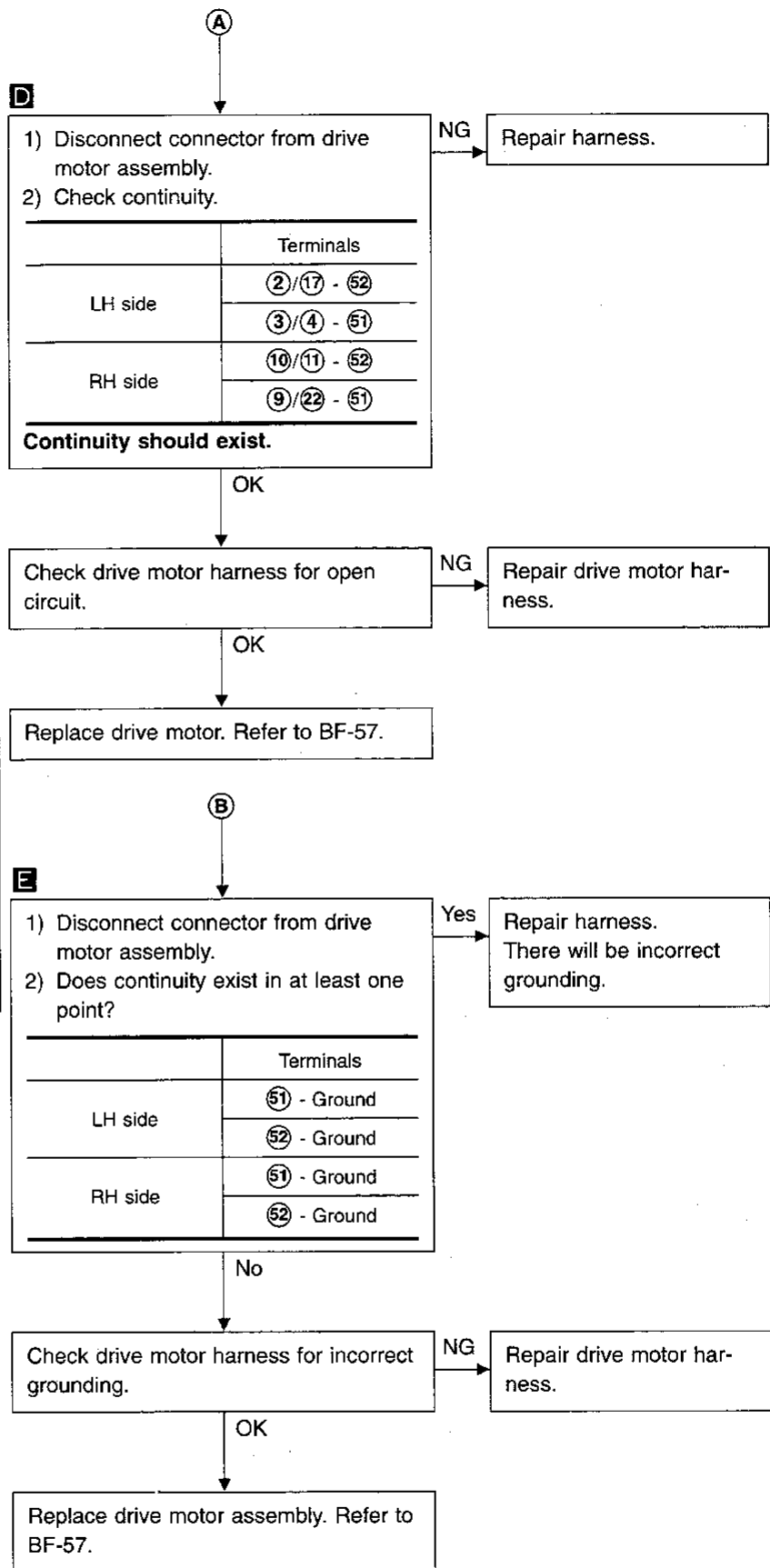
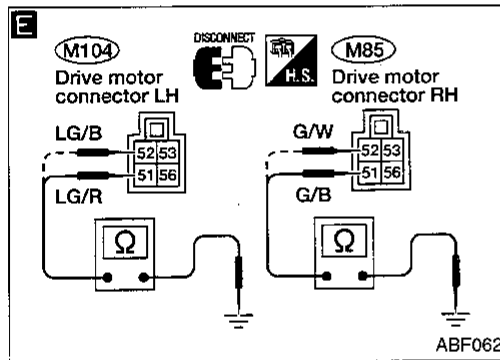
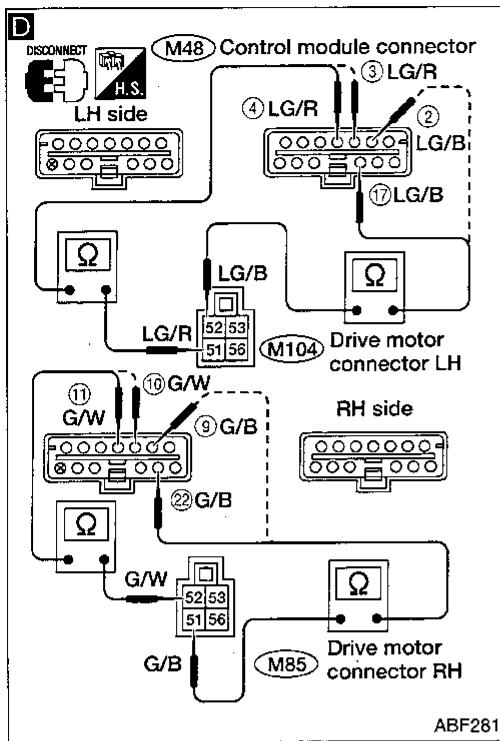

# AUTOMATIC SEAT BELT SYSTEM — Trouble Diagnoses

## Diagnostic Procedure 1 (Cont'd)

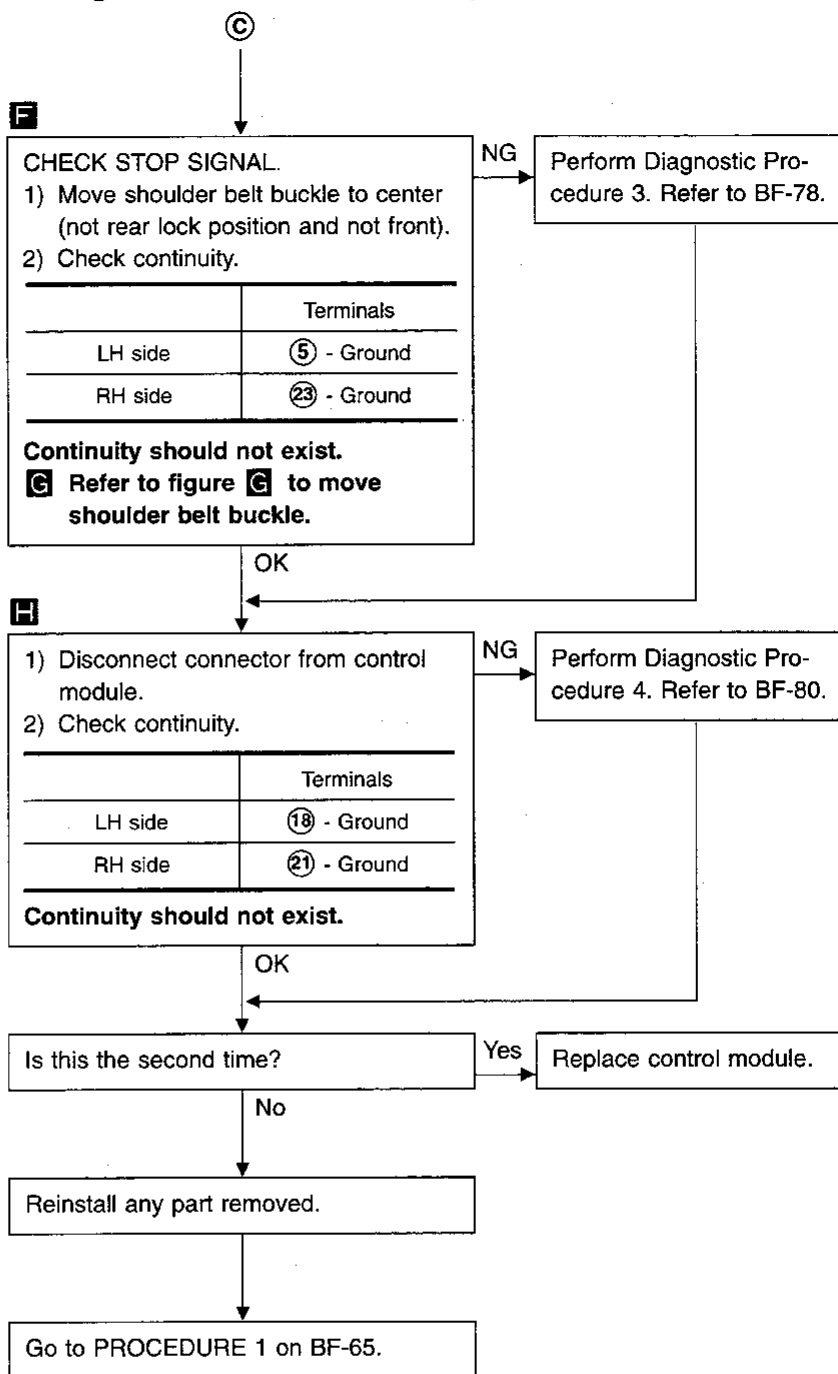
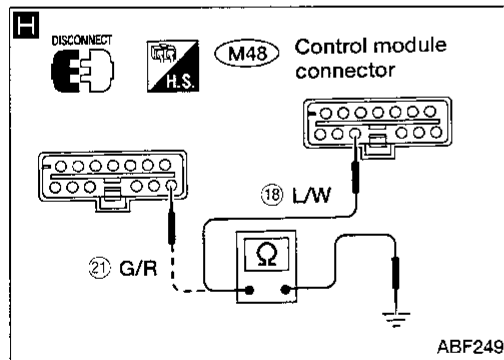
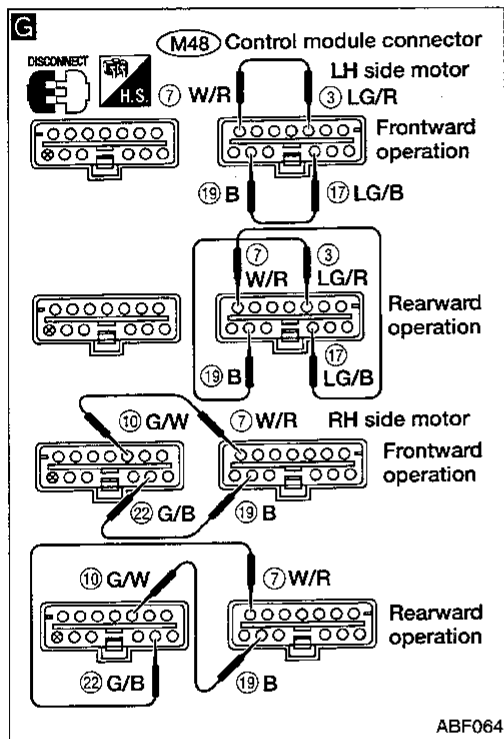
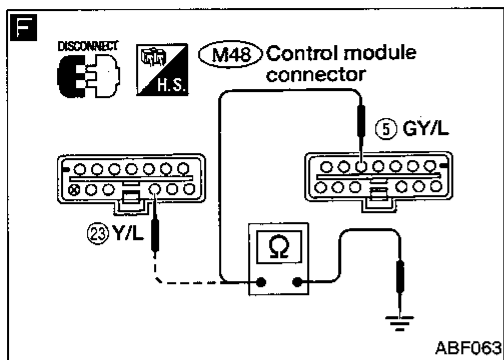

GI  
MA  
EM  
LC  
EF & EC  
FE  
AT  
FA  
RA  
BR  
ST  
BF  
HA  
EL  
IDX

# AUTOMATIC SEAT BELT SYSTEM — Trouble Diagnoses

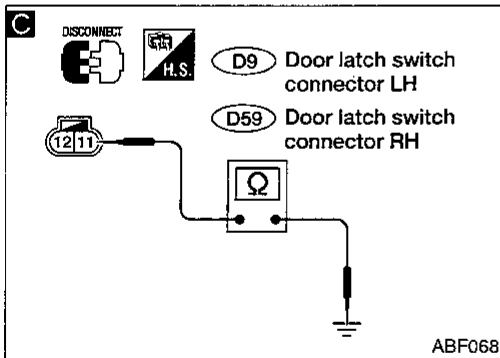
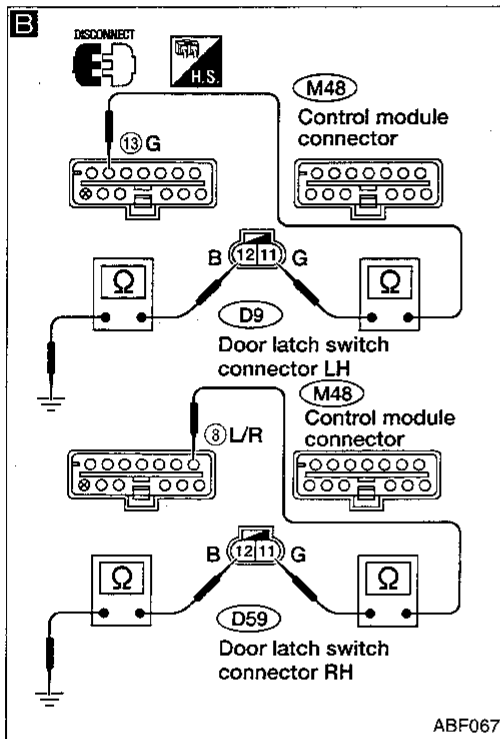
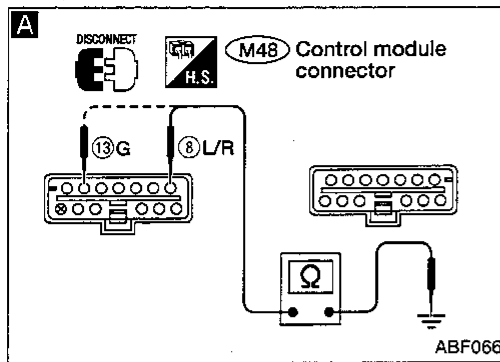

## Diagnostic Procedure 2

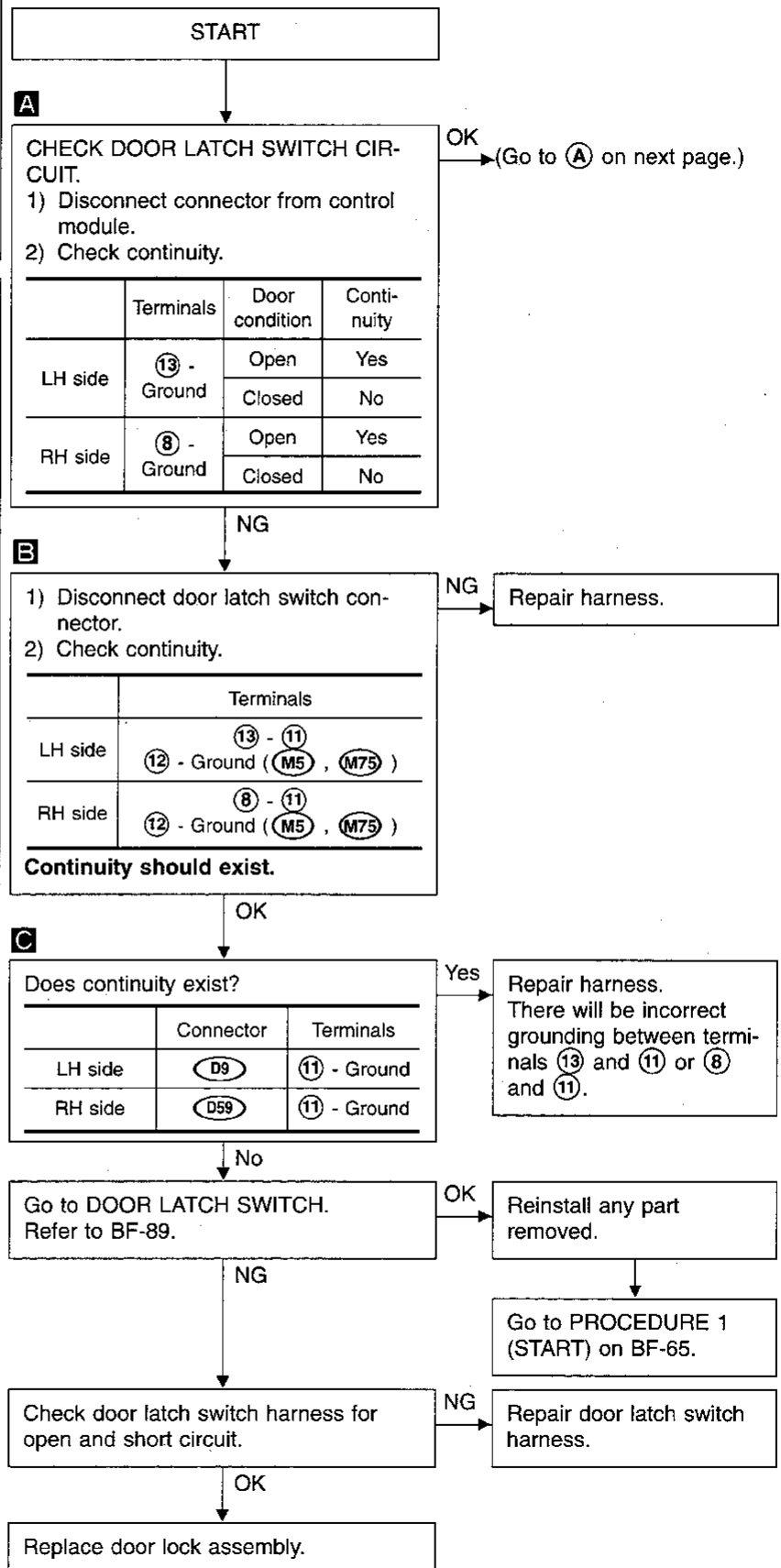

# AUTOMATIC SEAT BELT SYSTEM — Trouble Diagnoses

## Diagnostic Procedure 2 (Cont'd)

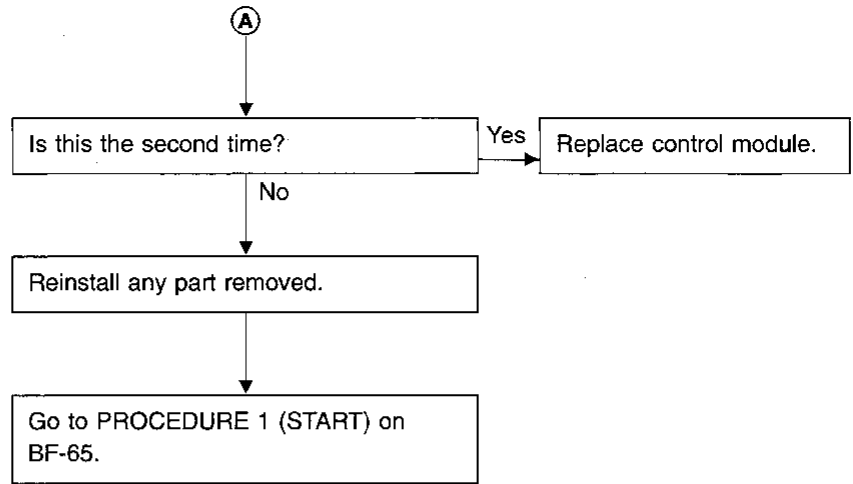

GI

MA

EM

LG

EF &

EC

FE

AT

FA

RA

BR

ST

**BF**

HA

EL

IDX

# AUTOMATIC SEAT BELT SYSTEM — Trouble Diagnoses

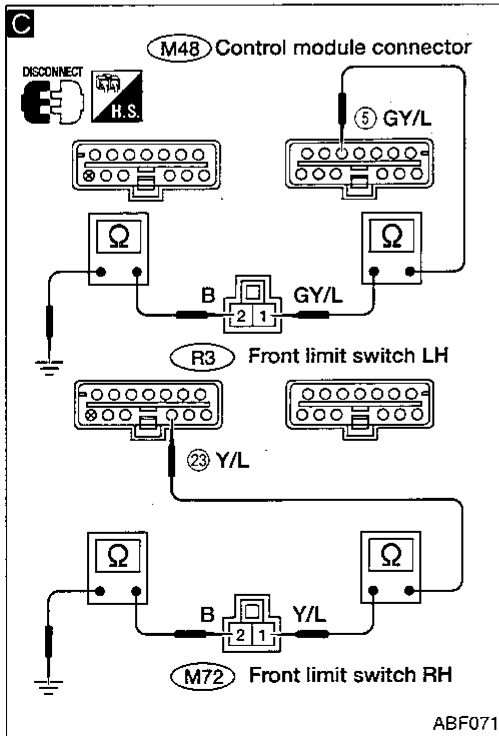
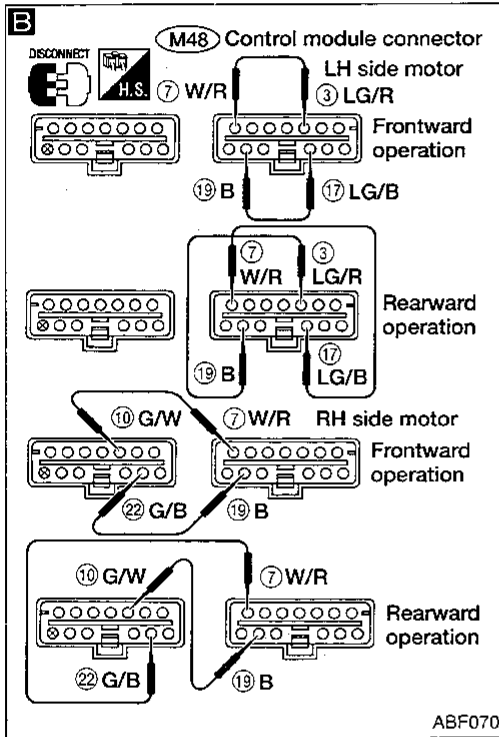
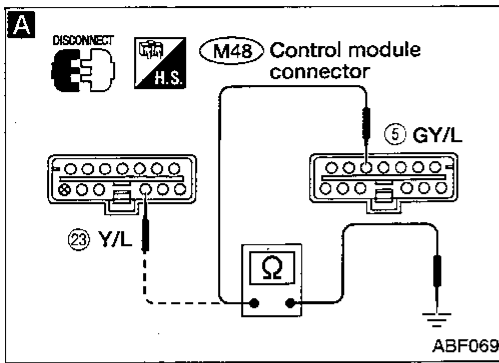

## Diagnostic Procedure 3

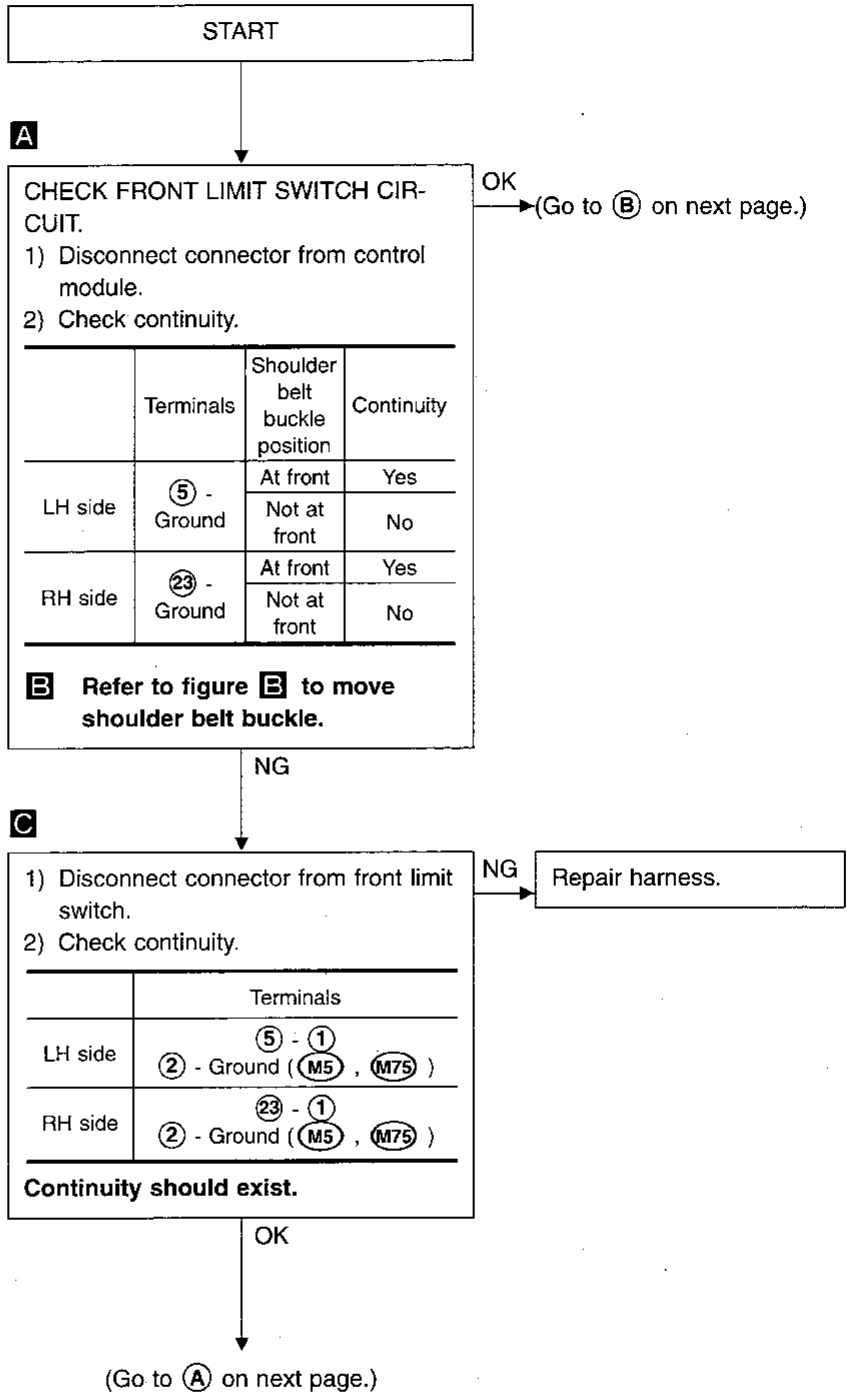



# AUTOMATIC SEAT BELT SYSTEM — Trouble Diagnoses

## Diagnostic Procedure 3 (Cont'd)

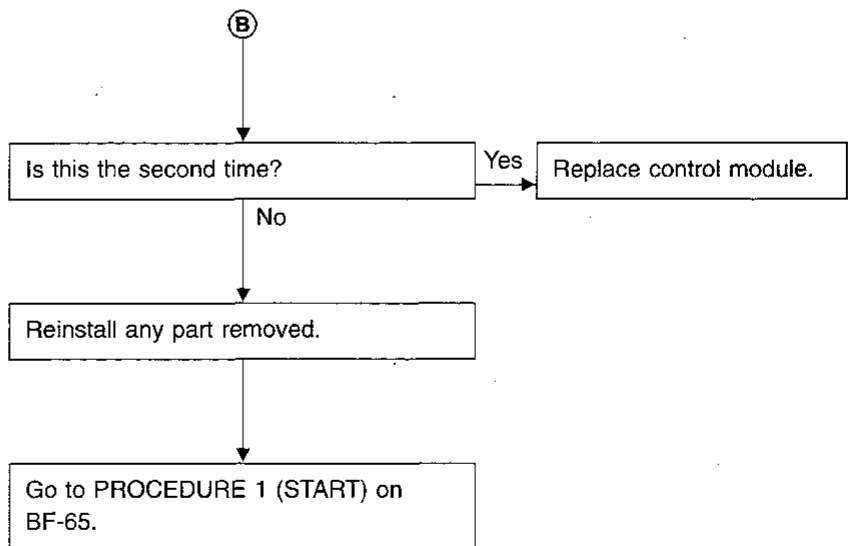
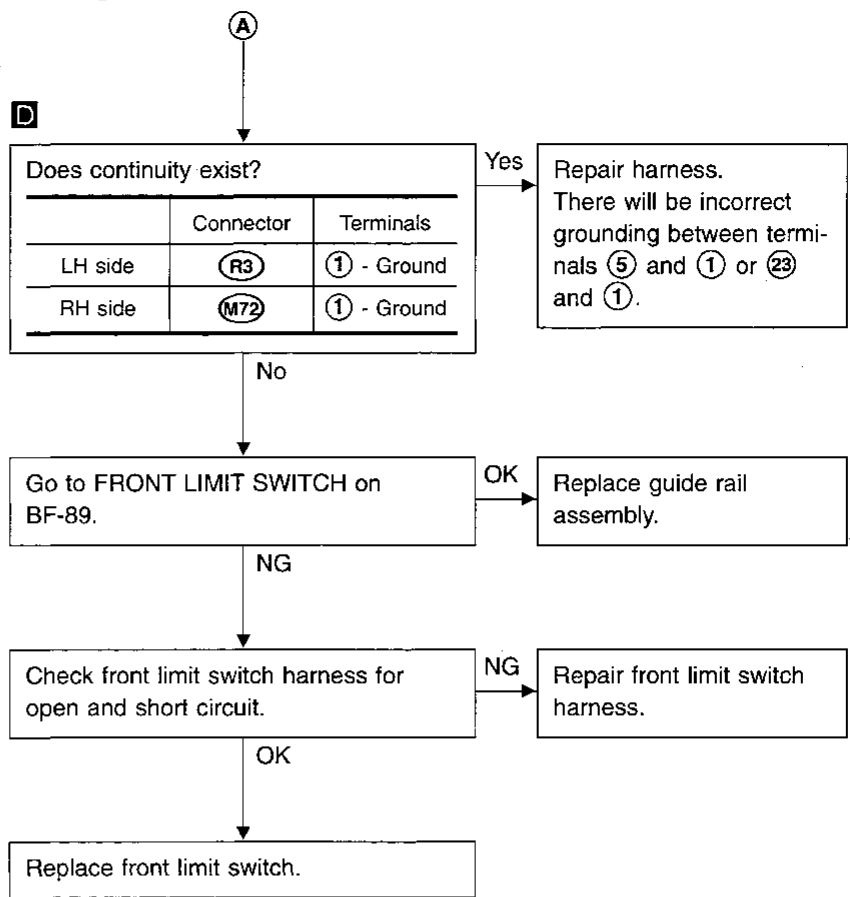
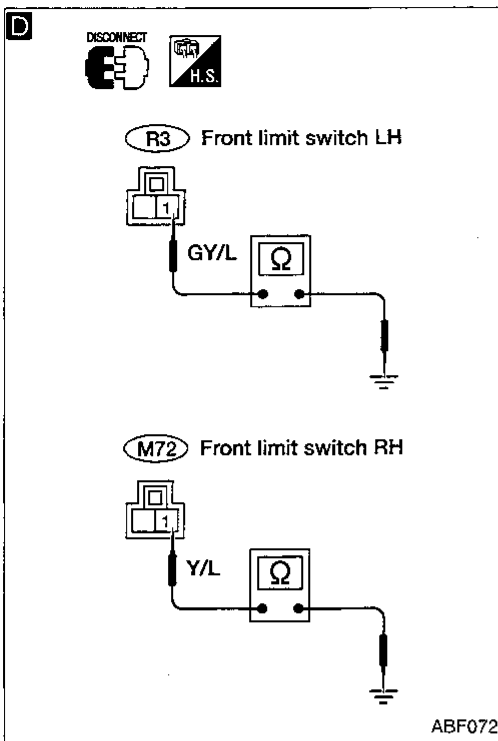

GI

MA

EM

LC

EF & EC

FE

AT

FA

RA

BR

ST

**BF**

HA

EL

IDX

# AUTOMATIC SEAT BELT SYSTEM — Trouble Diagnoses

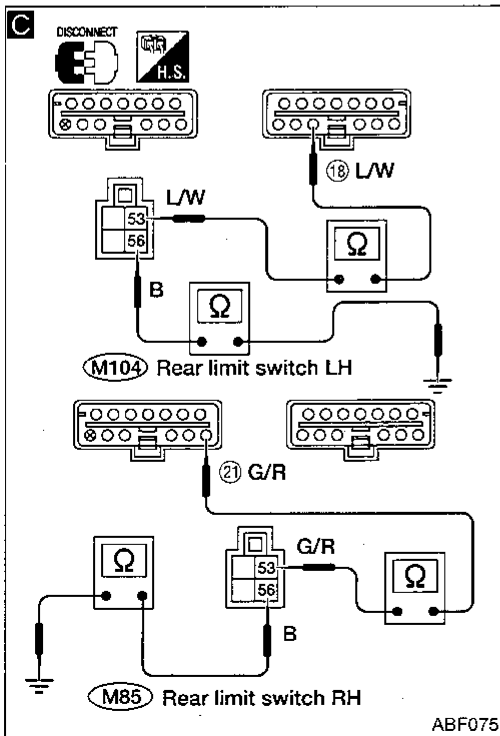
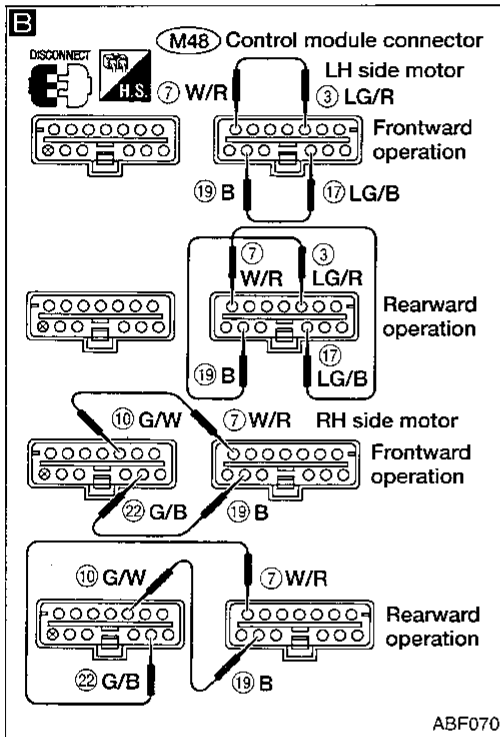
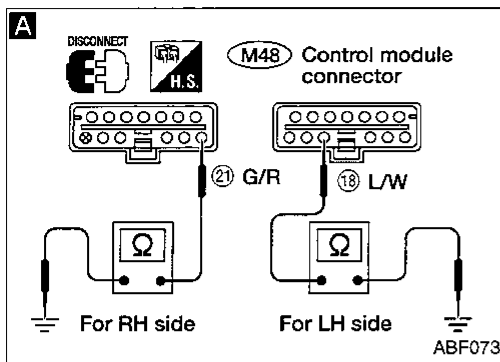

## Diagnostic Procedure 4

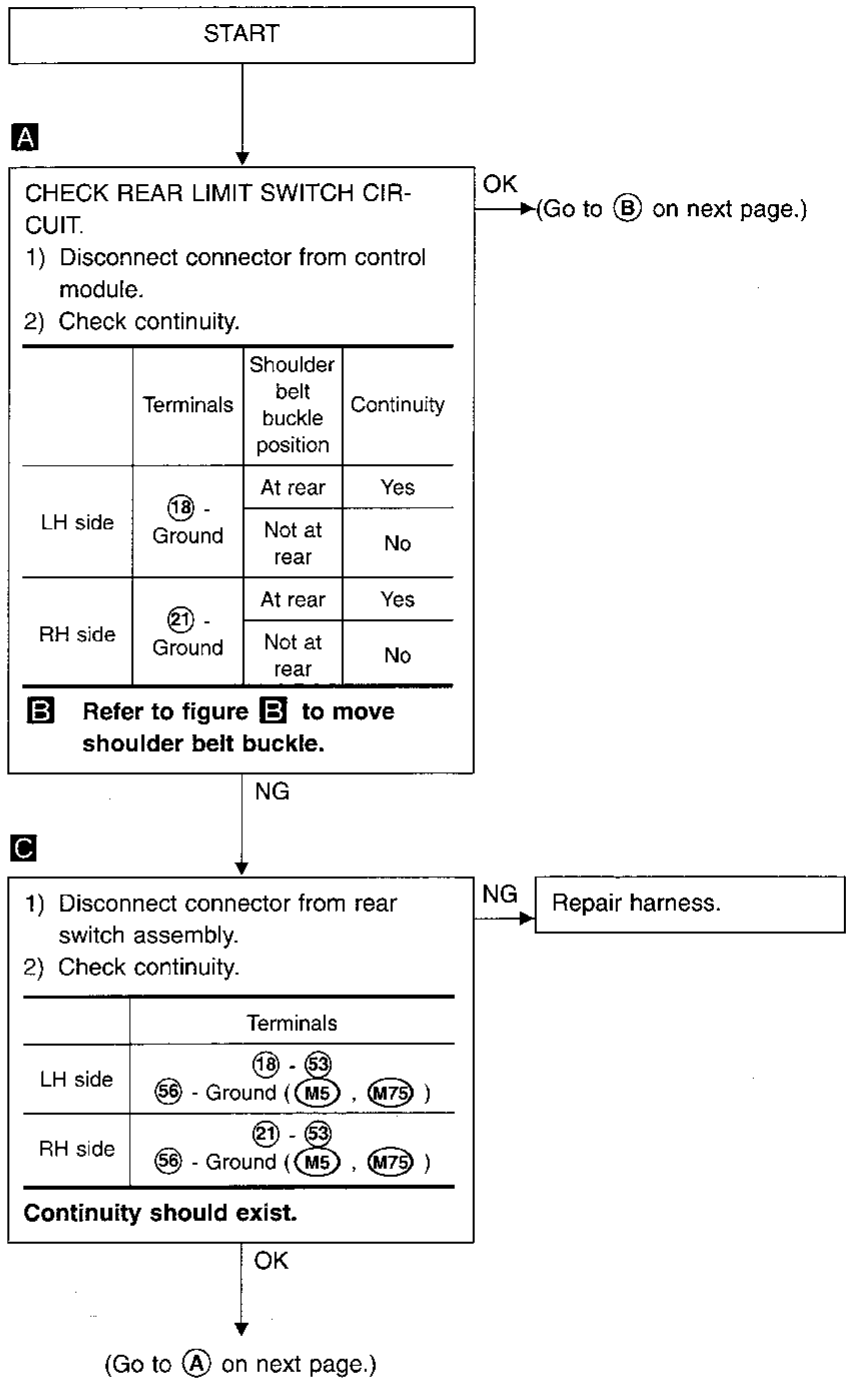

# AUTOMATIC SEAT BELT SYSTEM — Trouble Diagnoses

## Diagnostic Procedure 4 (Cont'd)

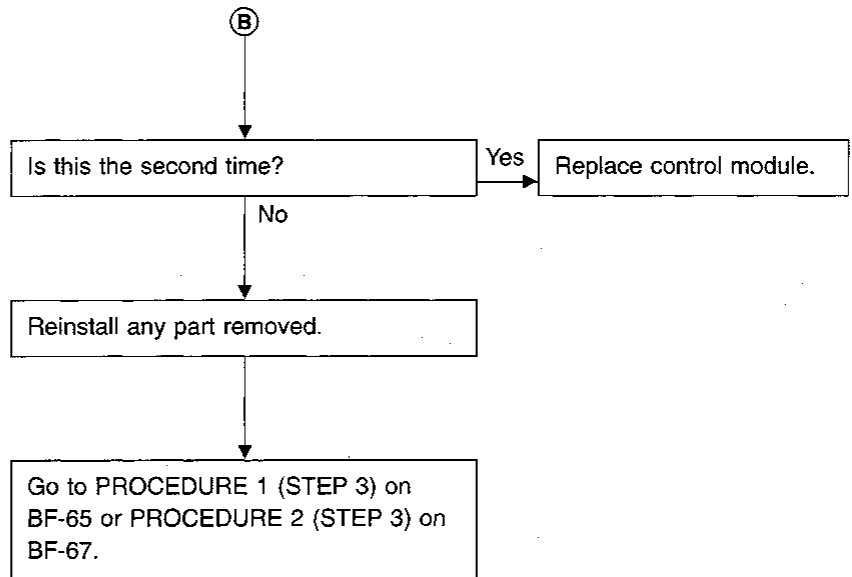
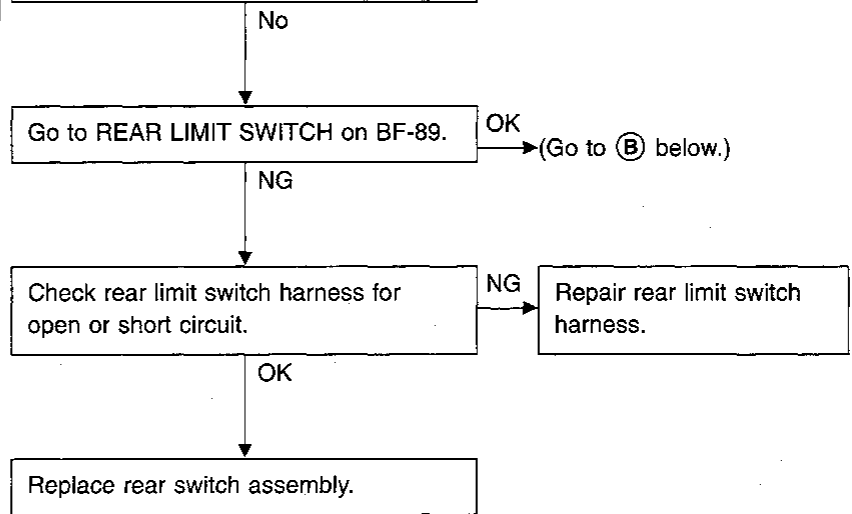
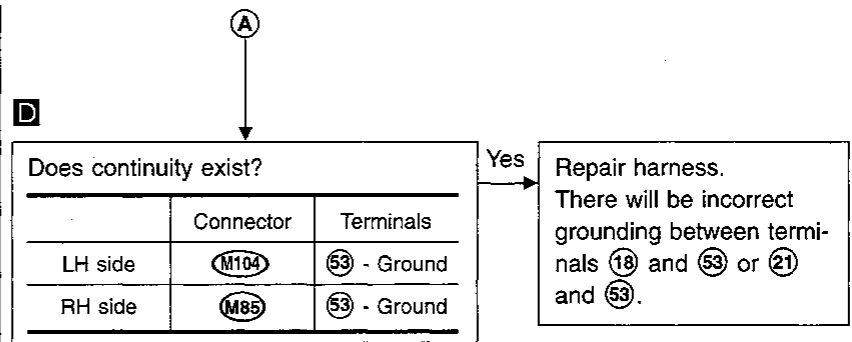
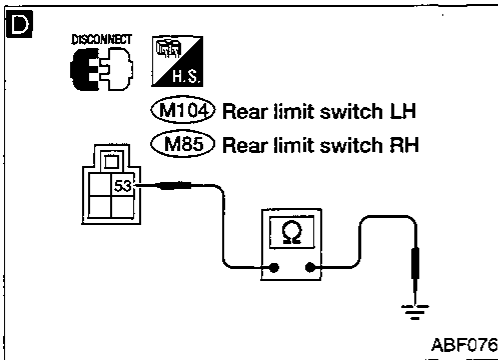

GI

MA

EW

LC

EF &amp;

EC

FE

AT

FA

RA

BR

ST

BF

HA

EL

IDX

# AUTOMATIC SEAT BELT SYSTEM — Trouble Diagnoses

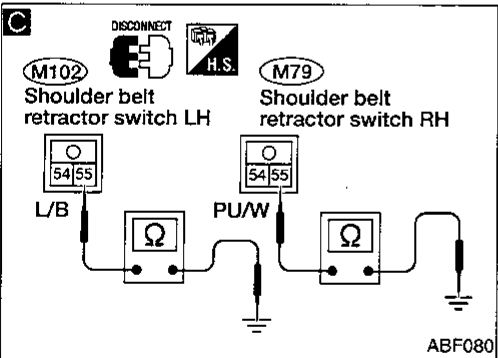
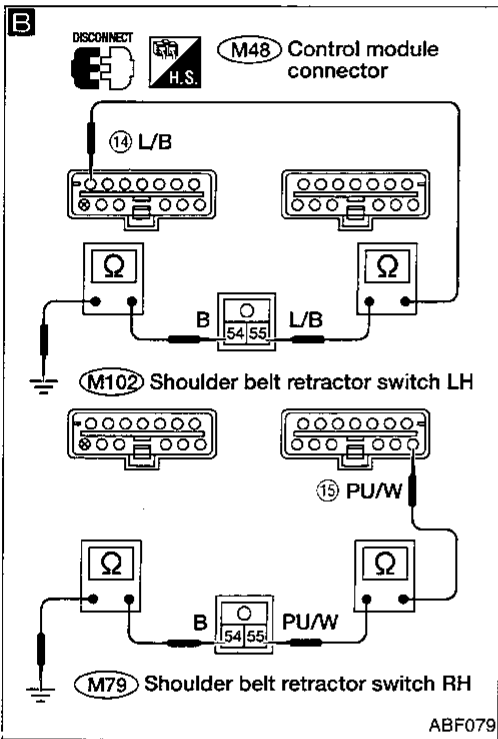
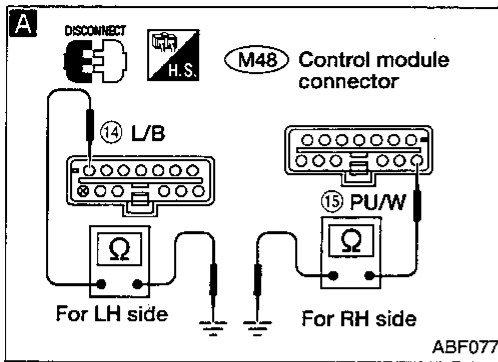

## Diagnostic Procedure 5

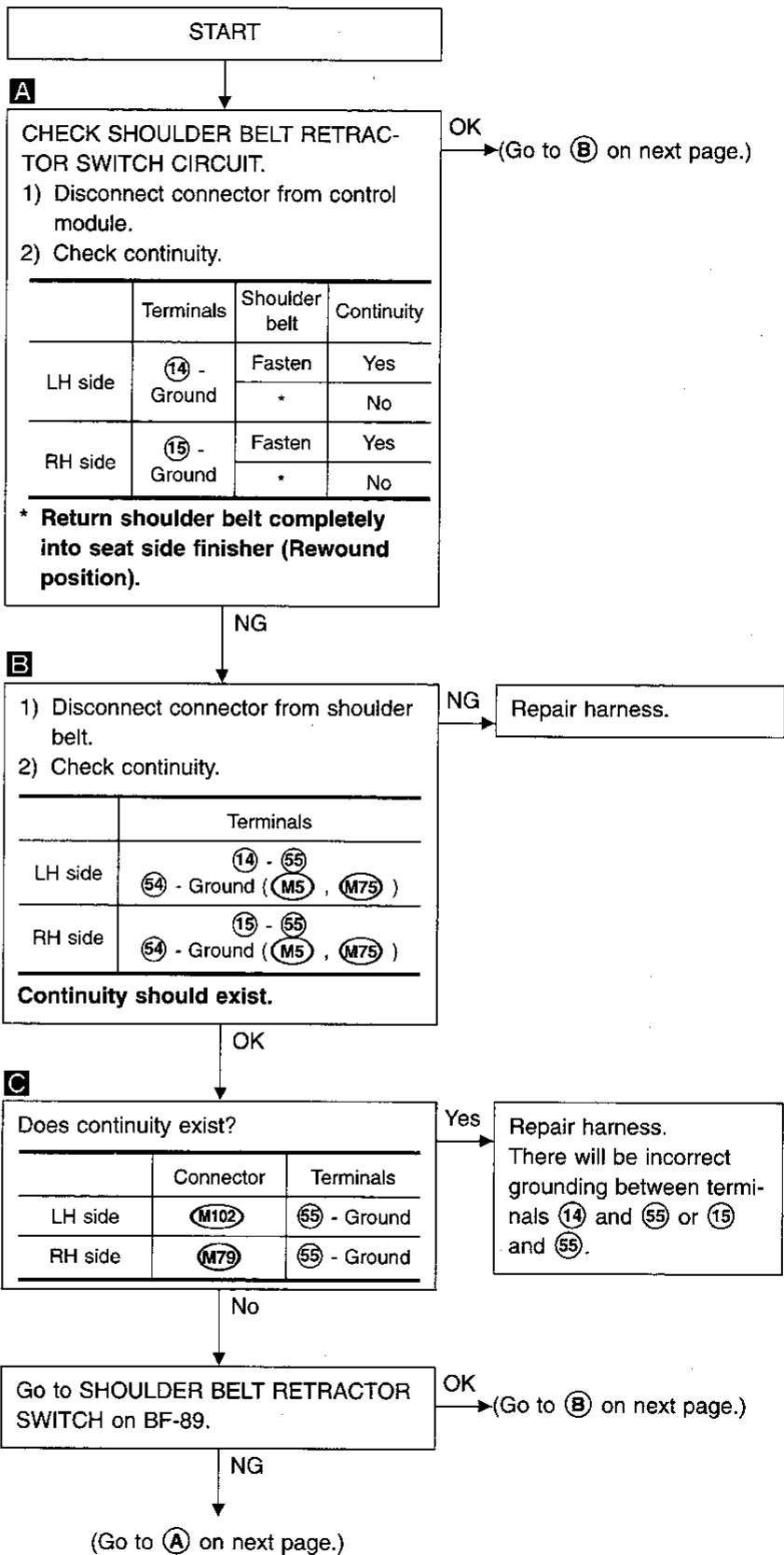

# AUTOMATIC SEAT BELT SYSTEM — Trouble Diagnoses

## Diagnostic Procedure 5 (Cont'd)

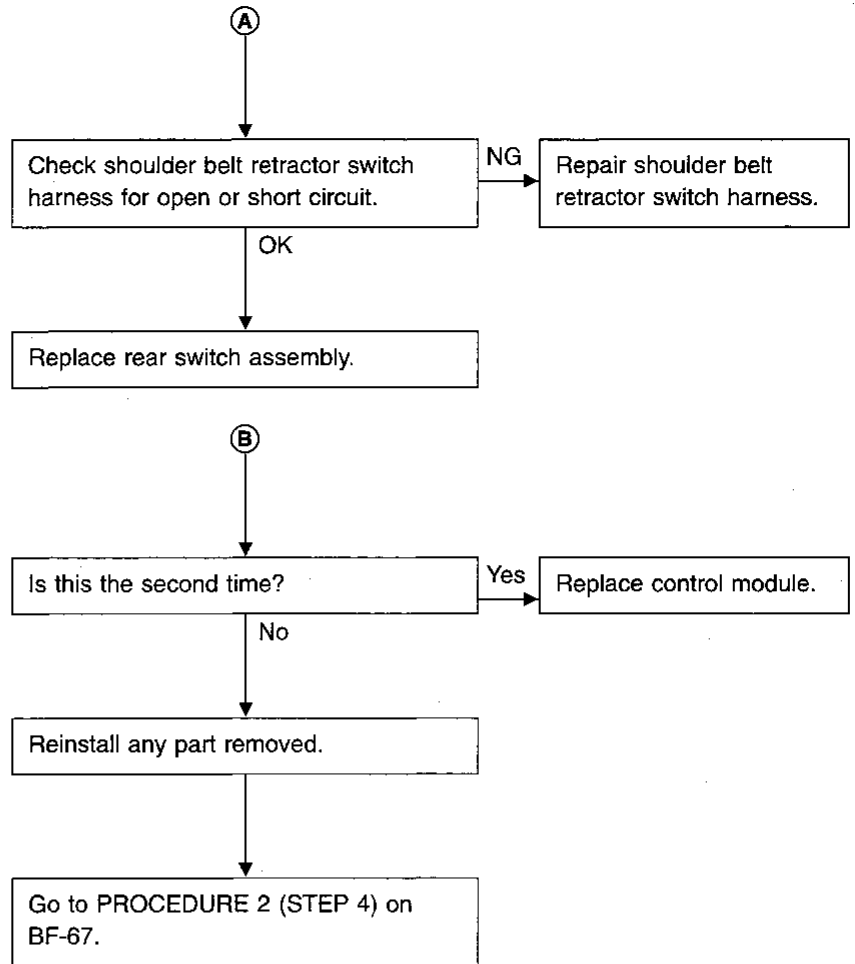

GI  
MA  
EM  
LC  
EF &  
EC  
FE  
AT  
FA  
RA  
BR  
ST  
BF  
HA  
EL  
IDX

# AUTOMATIC SEAT BELT SYSTEM — Trouble Diagnoses

## Diagnostic Procedure 6

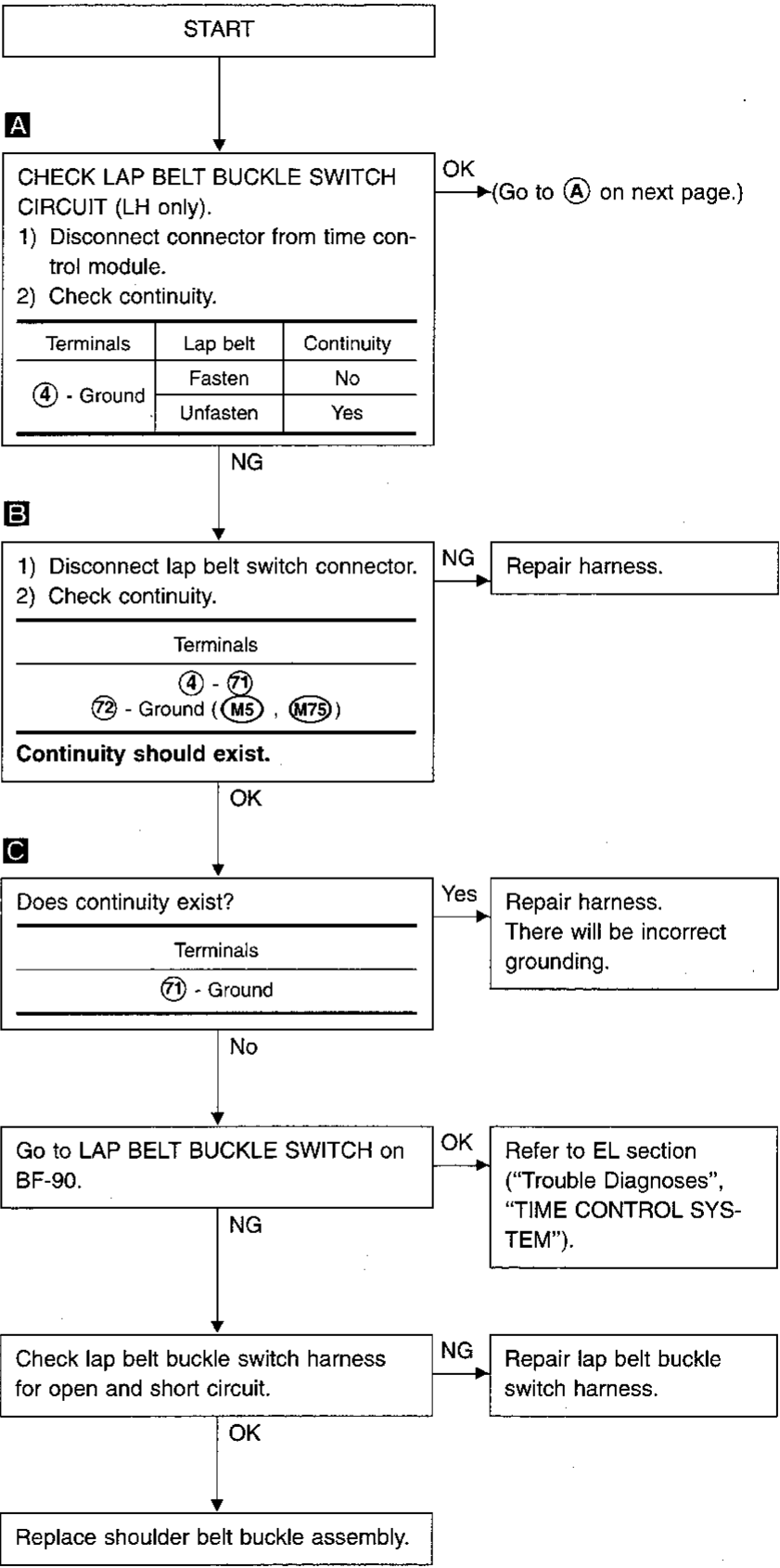
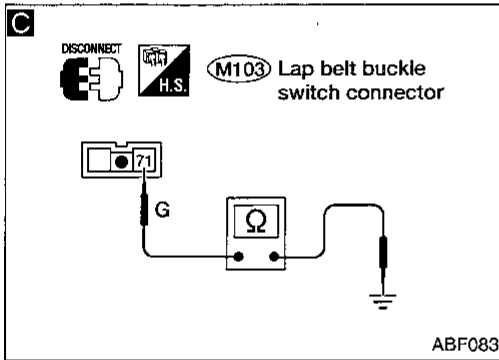
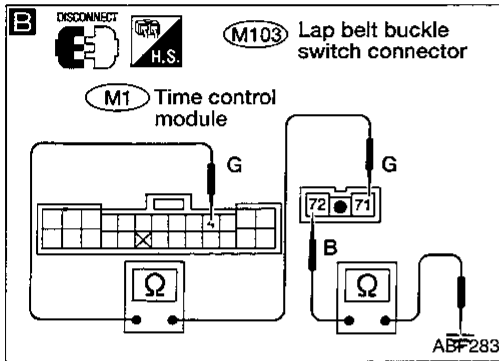
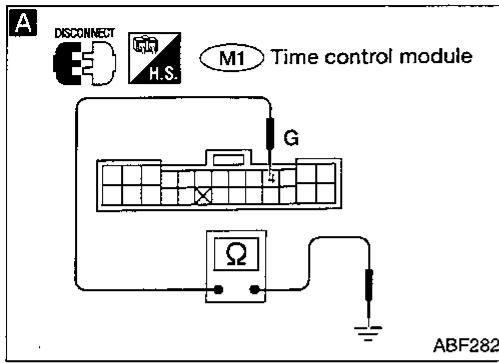

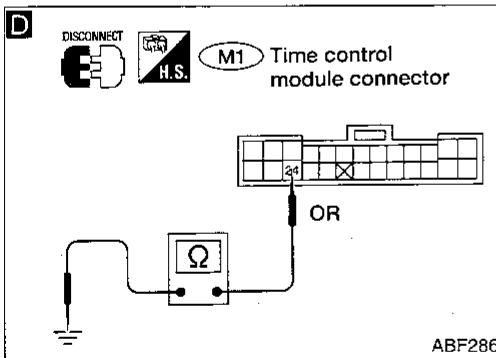
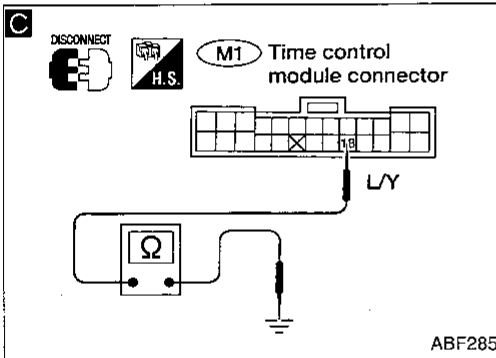
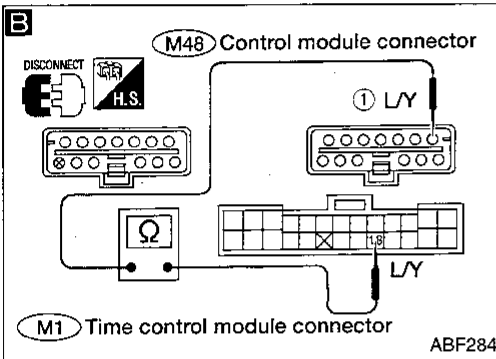
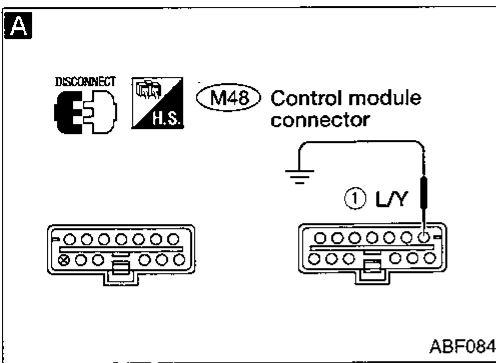

## Diagnostic Procedure 7

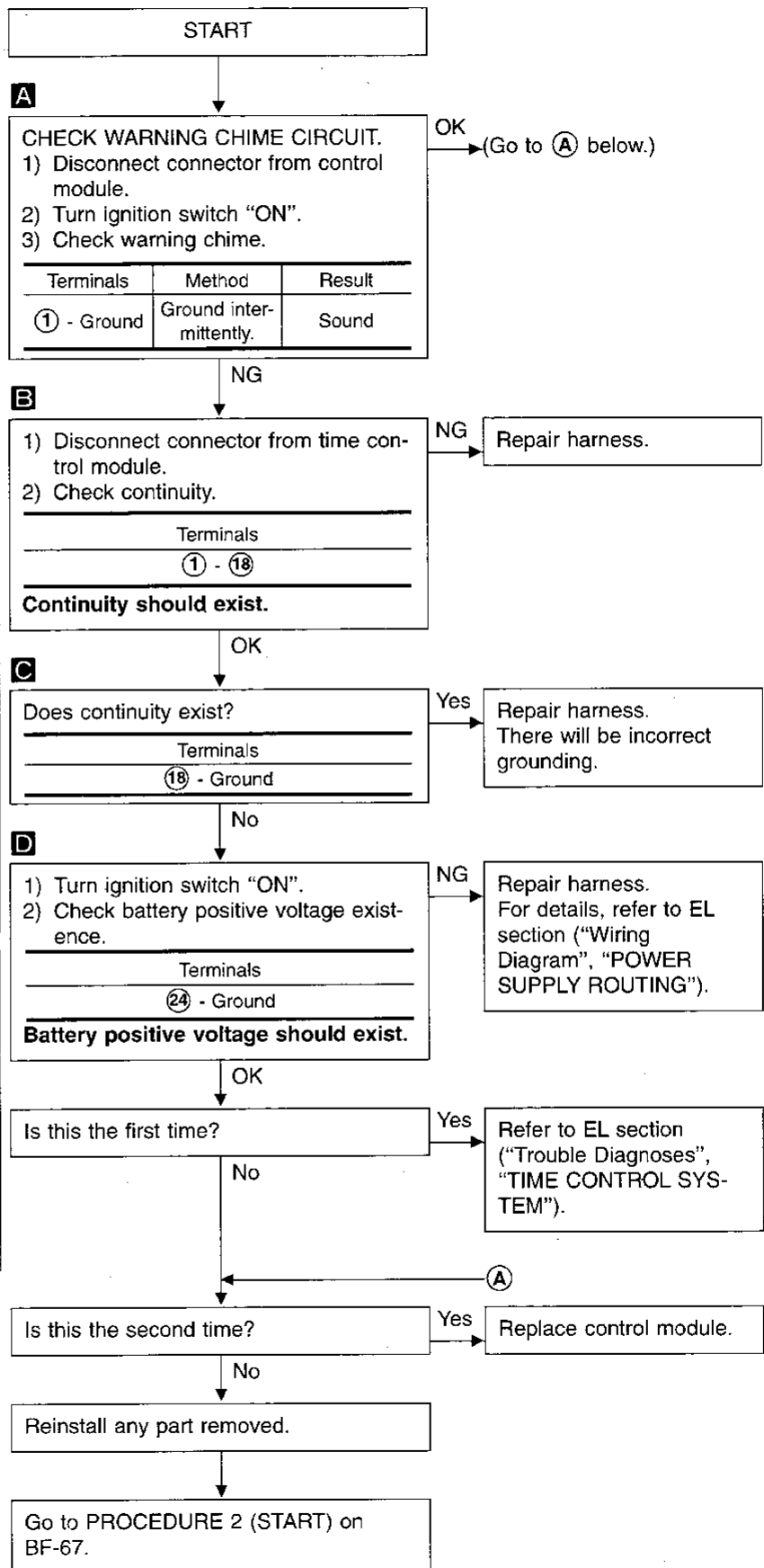

GI  
 MA  
 EM  
 LC  
 EF & EC  
 FE  
 AT  
 FA  
 RA  
 BR  
 ST  
 BF  
 HA  
 EL  
 IDX

# AUTOMATIC SEAT BELT SYSTEM — Trouble Diagnoses

## Diagnostic Procedure 8

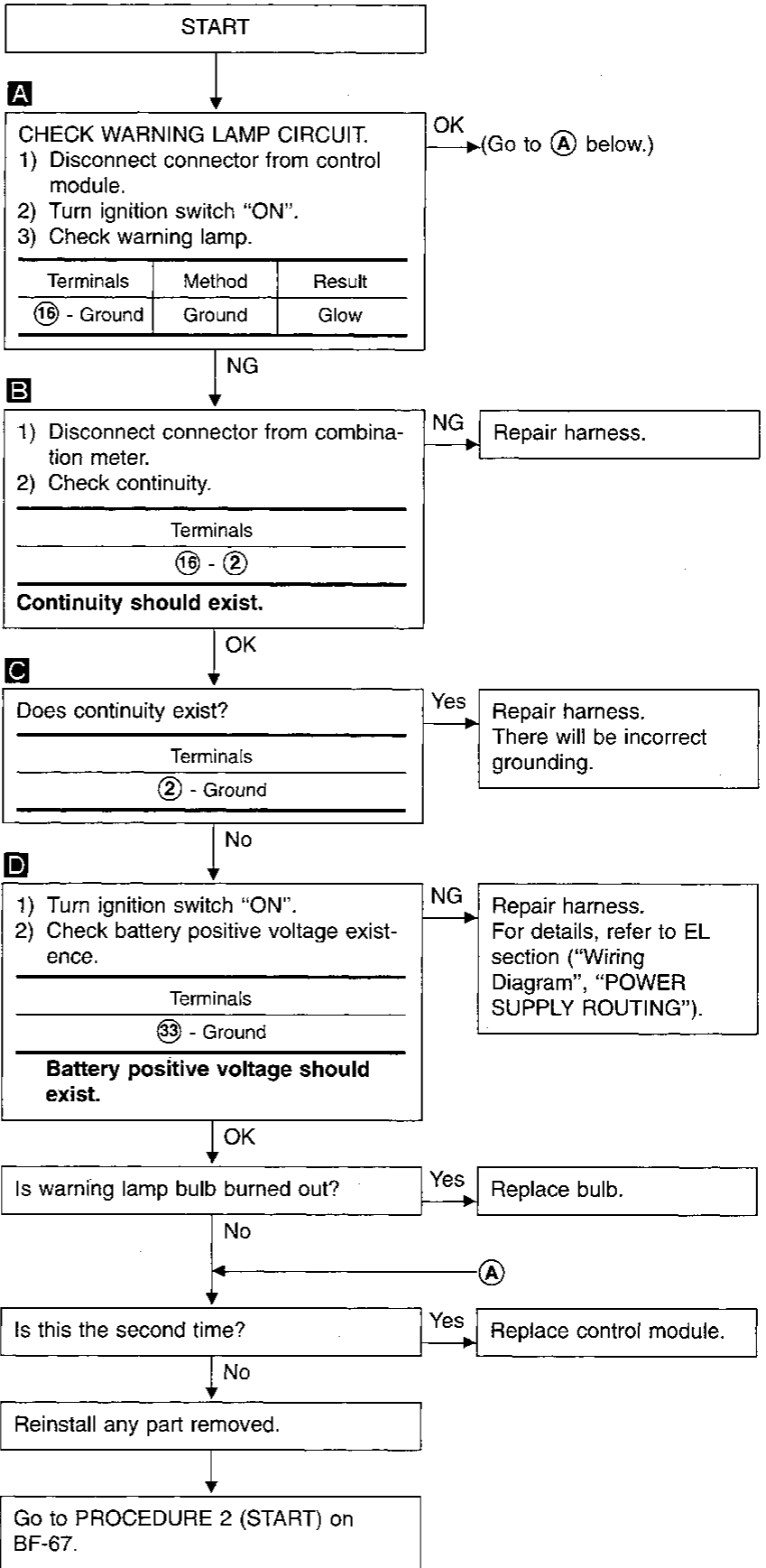
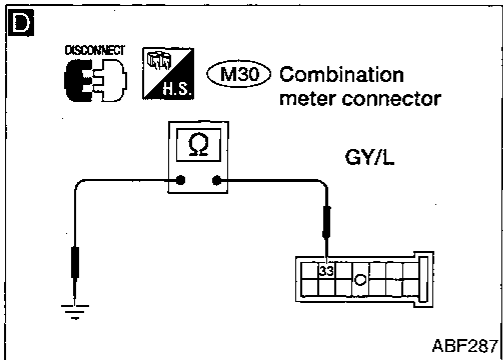
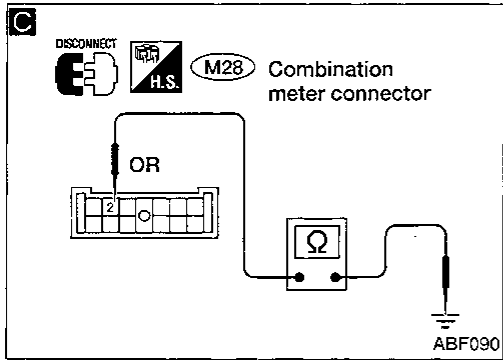
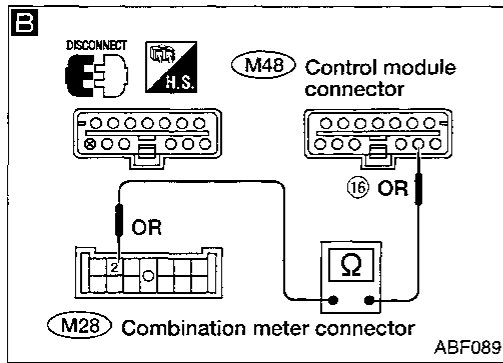
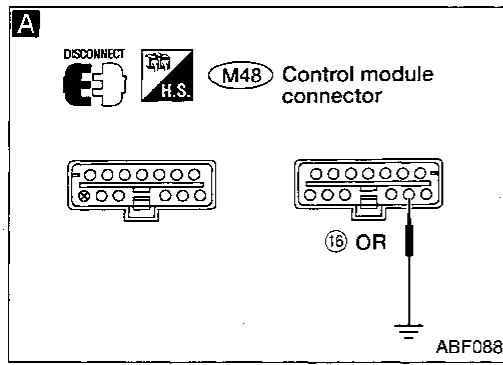



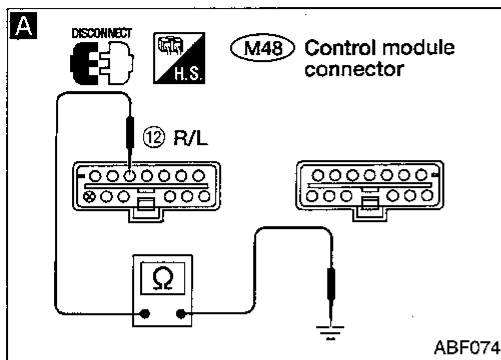

## Diagnostic Procedure 9

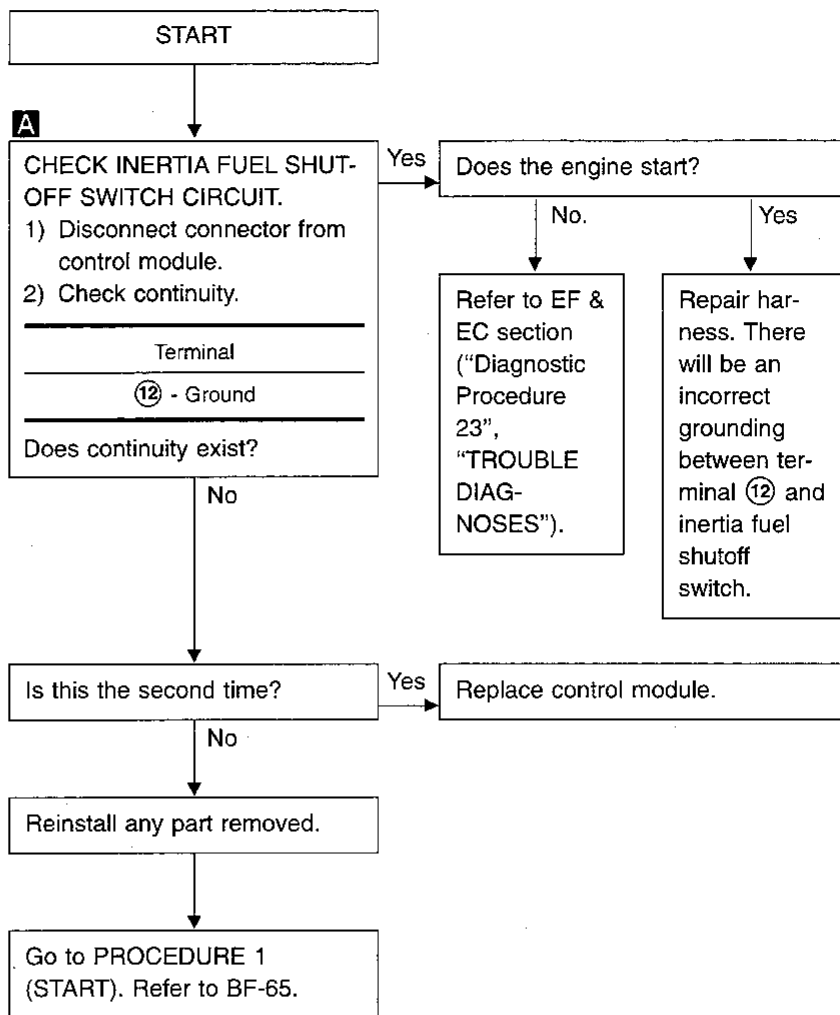

CI  
 MA  
 EM  
 LC  
 EF & EC  
 FE  
 AT  
 FA  
 RA  
 BR  
 ST  
**BF**  
 HA  
 EL  
 IDX

# AUTOMATIC SEAT BELT SYSTEM — Trouble Diagnoses

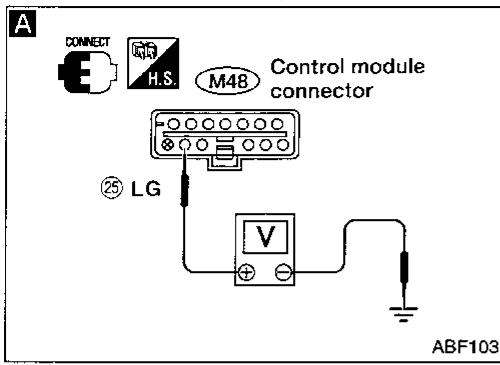

## Diagnostic Procedure 10

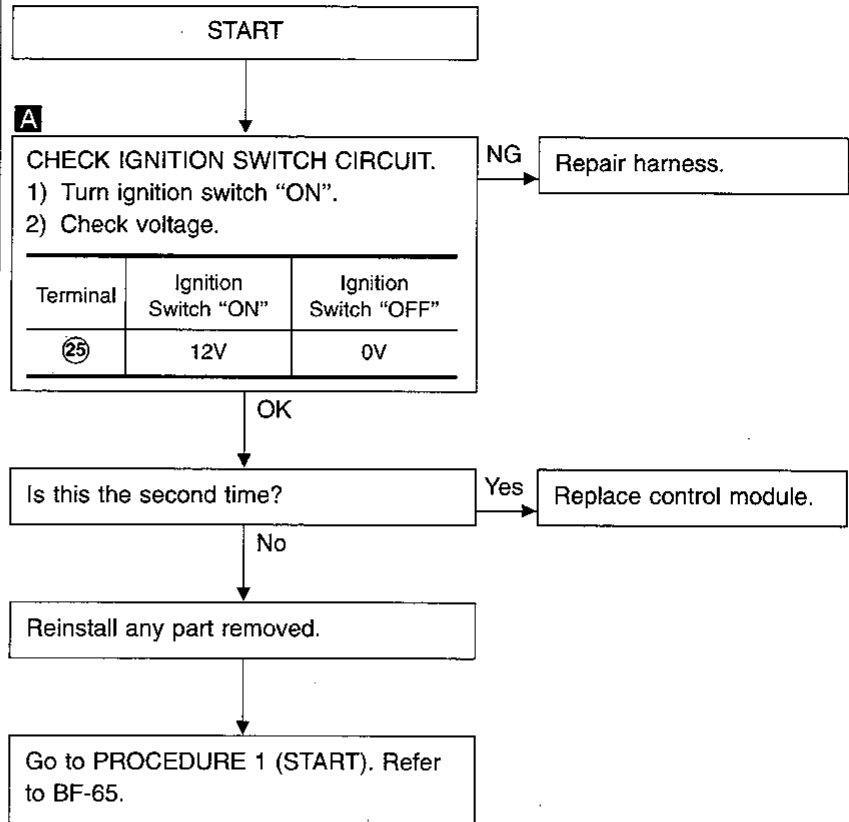

# AUTOMATIC SEAT BELT SYSTEM — Trouble Diagnoses

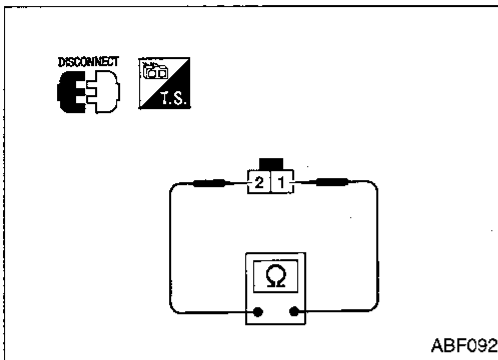

## Electrical Components Inspection

### FRONT LIMIT SWITCH

Condition	Continuity
Shoulder belt buckle is at the front end.	Yes
Shoulder belt buckle is not at the front end.	No

GI  
MA  
EM

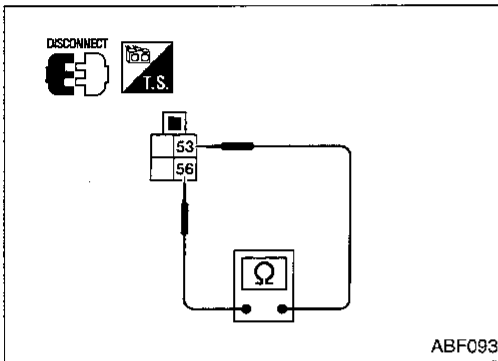

### REAR LIMIT SWITCH

Condition	Continuity
Shoulder belt buckle is at the rear end.	Yes
Shoulder belt buckle is not at the rear end.	No

LC  
EF &  
EC  
FE

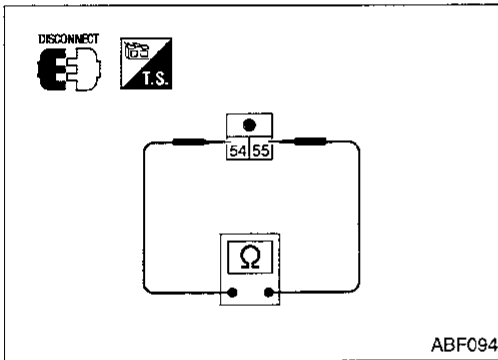

### SHOULDER BELT RETRACTOR SWITCH

Condition	Continuity
Fastened	Yes
Unfastened (Rewound position)	No

AT  
FA  
RA  
BR

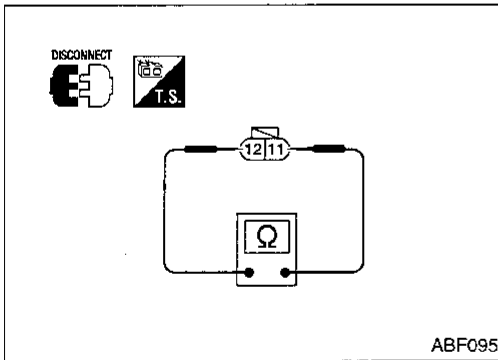

### DOOR LATCH SWITCH (Built-in door lock assembly)

Door condition	Continuity
Open	Yes
Closed	No

ST  
BF  
HA  
EL  
IDX

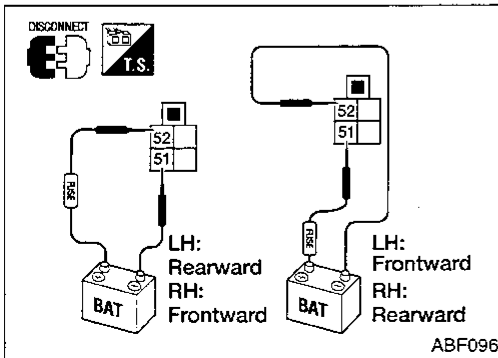

### DRIVE MOTOR ASSEMBLY

	Terminals		Buckle operation
	⊕	⊖	
Drive motor LH	52	51	Rearward
	51	52	Frontward
Drive motor RH	52	51	Frontward
	51	52	Rearward

If NG, replace drive motor. Refer to BF-57

# AUTOMATIC SEAT BELT SYSTEM — Trouble Diagnoses

## Electrical Components Inspection (Cont'd)

### LAP BELT BUCKLE SWITCH (Built-in lap belt buckle for LH side)

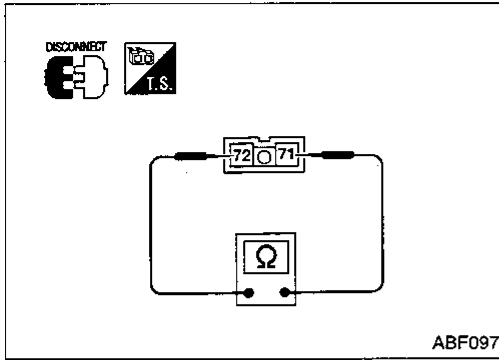

Condition	Continuity
Fastened	No
Unfastened	Yes

# THREE POINT TYPE SEAT BELTS

Second row seat belt retractor  
RH shown

(With second row bench seat)

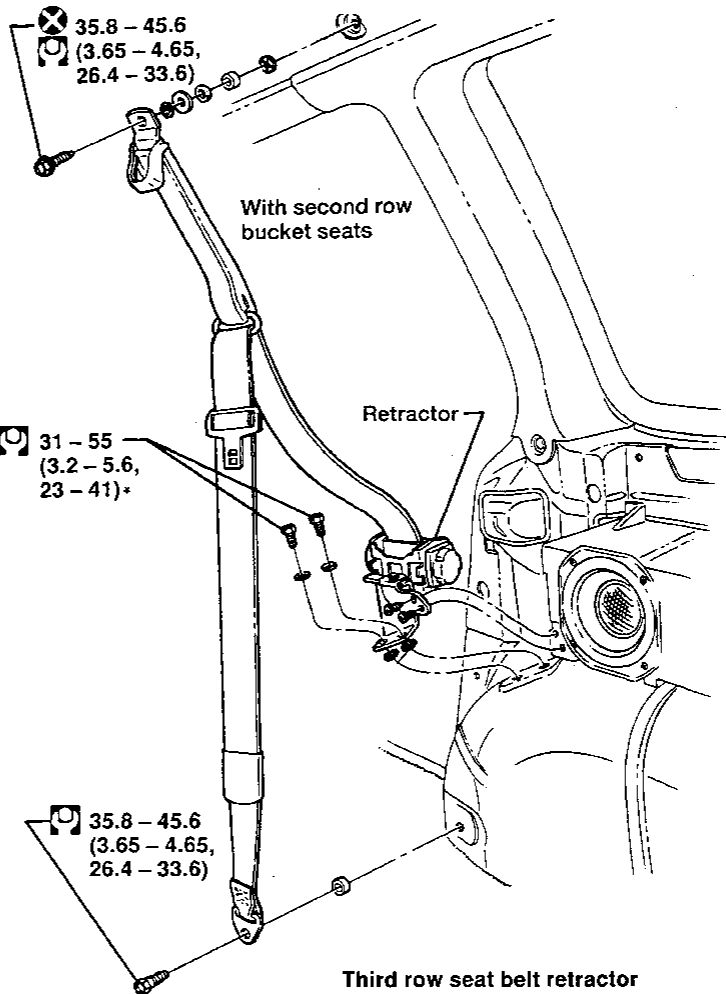
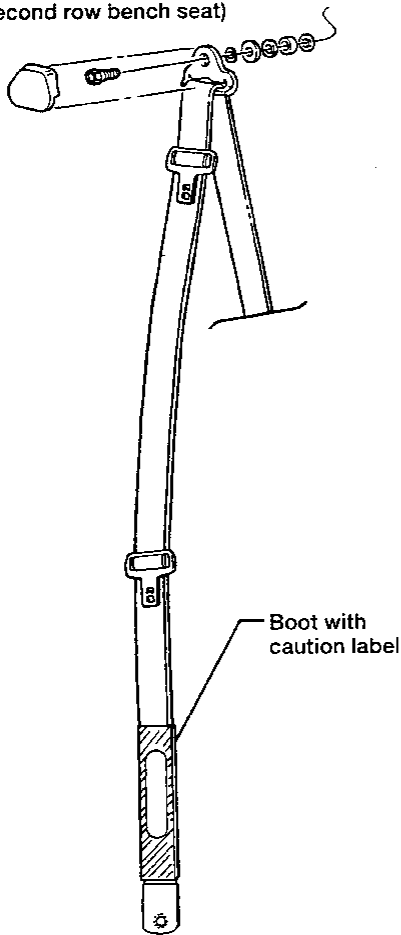

Third row seat belt retractor

Bench seat buckle

(Ref.)  
rear  
cushion

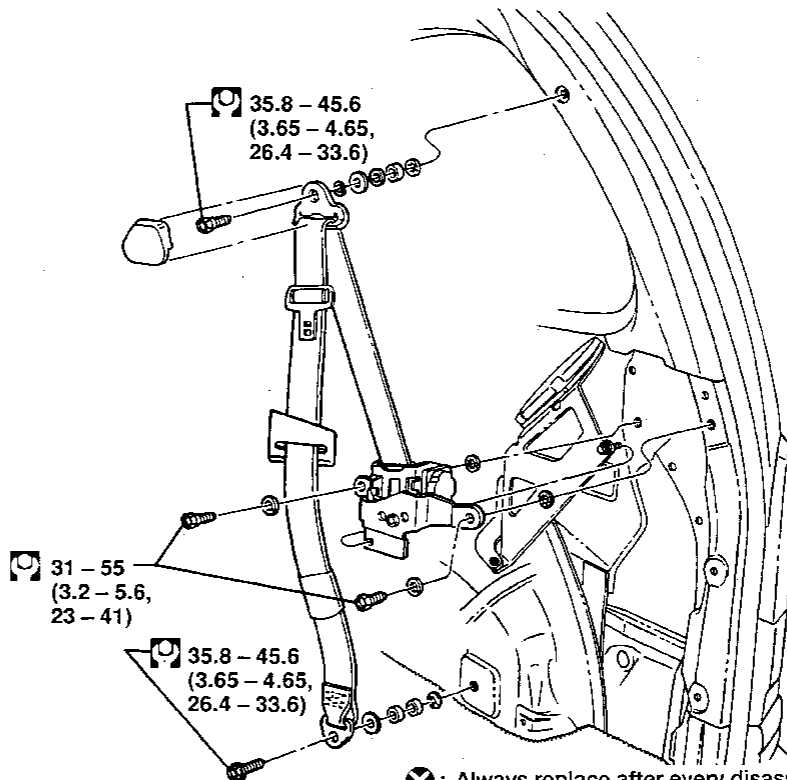
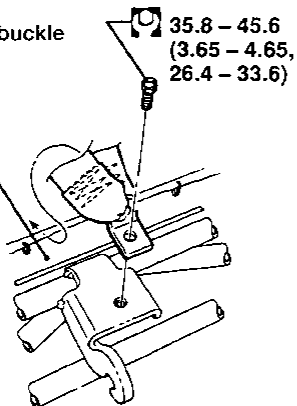

\* Important: Tighten LH second row seat belt retractor bolt to 35.8 - 45.6 N·m (3.65 - 4.65 kg-m, 26.4 - 33.6 ft-lb)

⊗ : Always replace after every disassembly  
Ⓜ : N-m (kg-m, ft-lb)

GI  
MA  
EM  
LC  
EF & EC  
FE  
AT  
FA  
RA  
BR  
ST  
BF  
HA  
EL  
IDX

ABF253

# SUN ROOF

- After any adjustment, check sun roof operation and lid alignment.
- Handle finisher plate and glass lid with care so not to damage it.
- It is desirable for easy installation to mark each point before removal.
- Always synchronize the sun roof motor in the closed position.

## CAUTION:

- Always work with a helper.
- Remove sun roof frame from rear door opening.

## REMOVAL AND INSTALLATION

- ① Remove front side of roof trim up to room lamp.
- Do not use excessive force and take care not to damage roof trim.
- ② Remove sun roof motor.
- ③ Open sunshade plate.
- ④ Remove sliding rail fixing screws.
- ⑤ Move sliding rail to back position.
- ⑥ Remove sun roof glass.
- ⑦ Disconnect four sun roof drain hoses from guide rail assembly.
- ⑧ Remove guide rail assembly with sliding rail and sun shade plate.
- Installation is basically the reverse order of removal.

## DISASSEMBLY AND ASSEMBLY — Guide rail assembly

- ⑨ Separate guide rail assembly from sliding rail and sun shade plate.
- ⑩ Remove six rivets and sun roof motor bracket.
- ⑪ Remove ten metal clips securing cables to guide rail.
- ⑫ Remove cables.
- Assembly is basically the reverse order of disassembly.

## REMOVAL AND INSTALLATION — Sun roof drain hoses

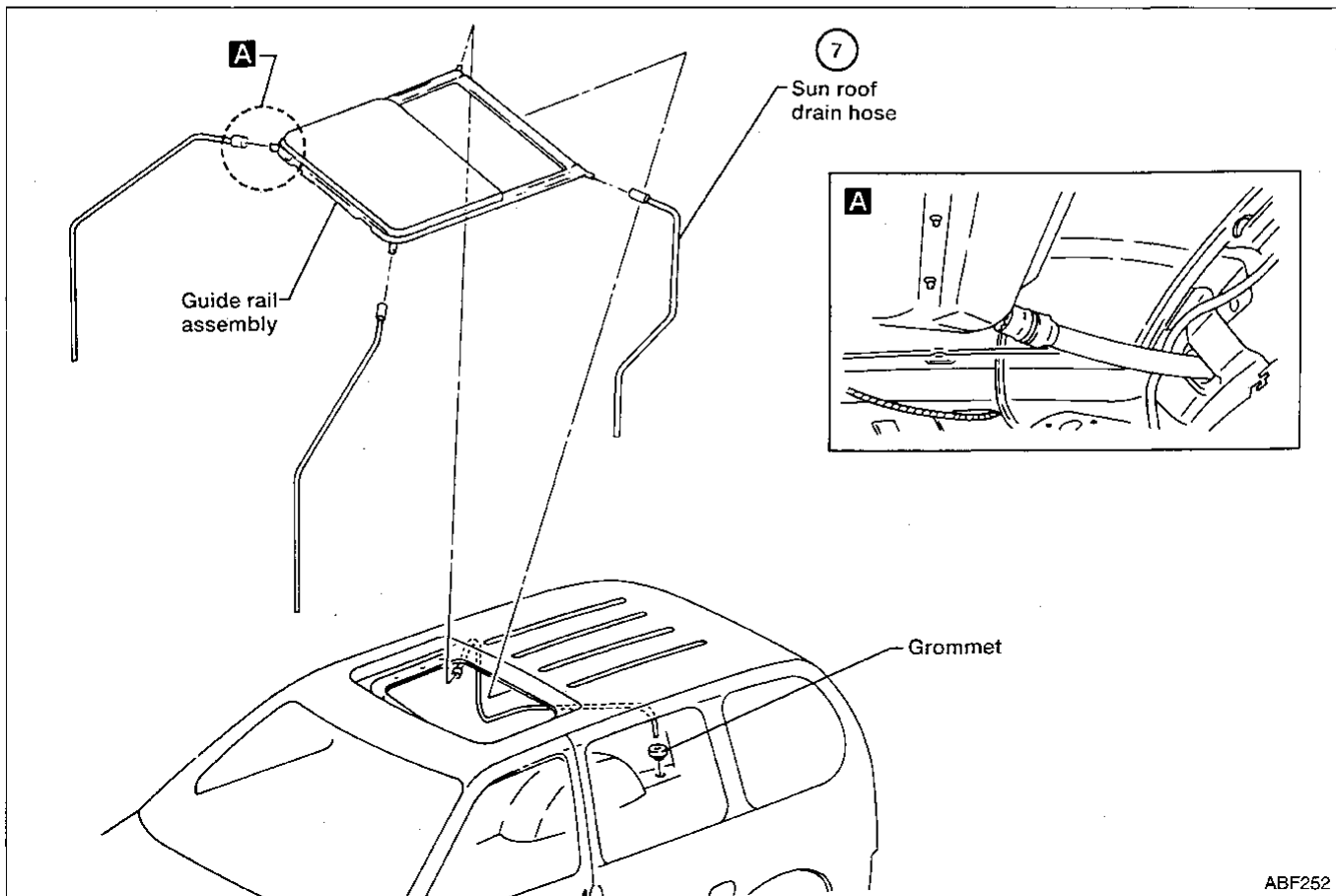

ABF252

# SUN ROOF

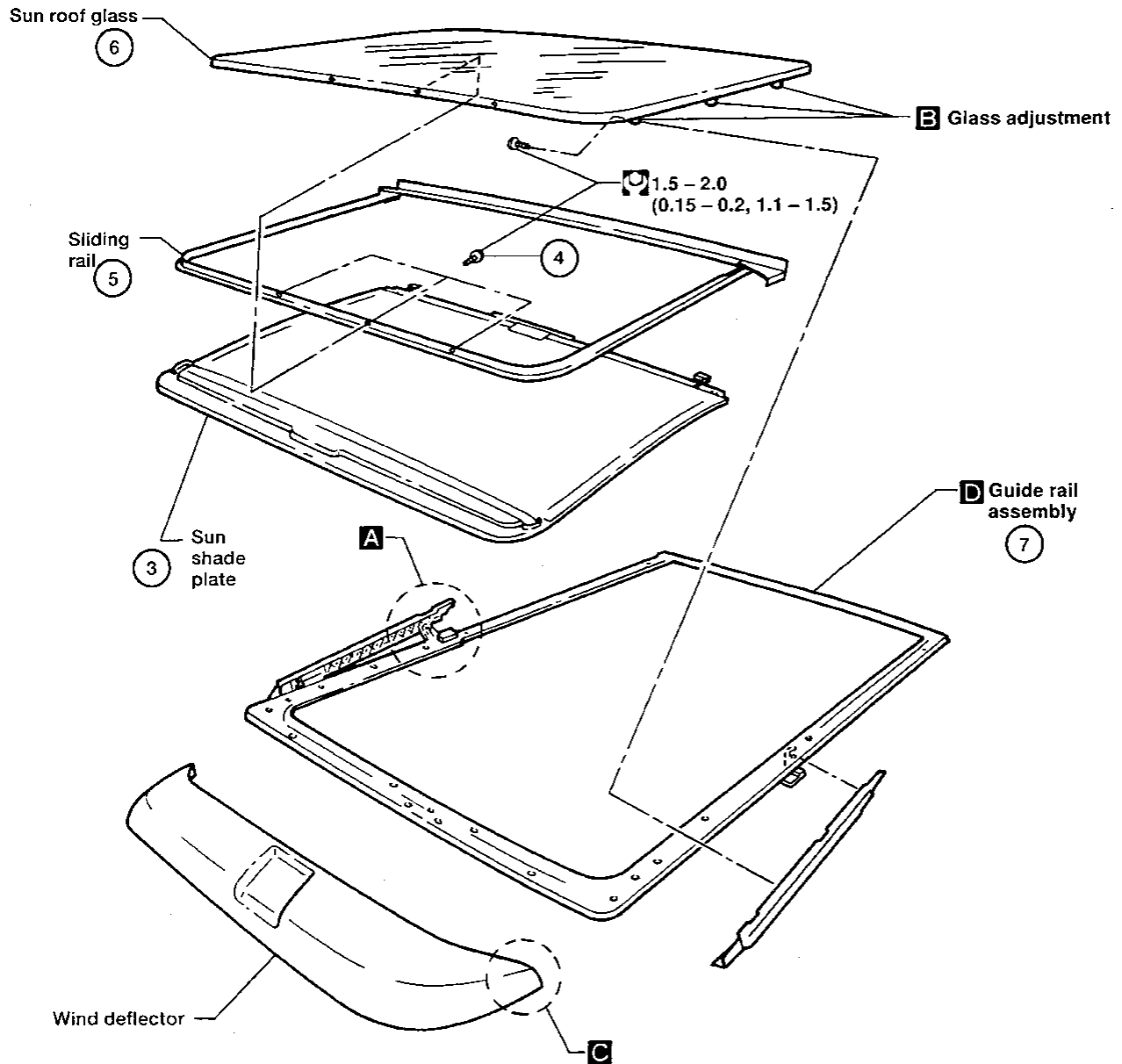
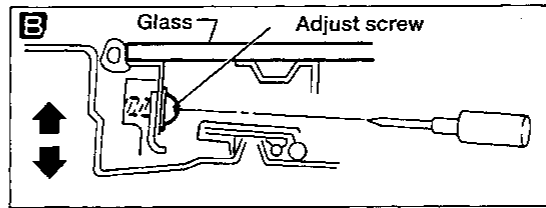
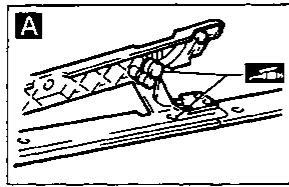

- : N-m (kg-m, lb-ft)
- : Should be lubricated with grease

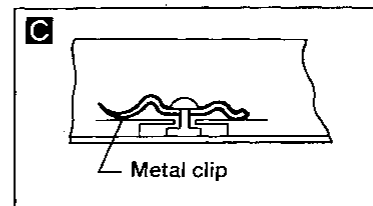

GI  
MA  
EM  
LC  
EF &  
EC  
FE  
AT  
FA  
RA  
BR  
ST  
BF  
HA  
EL  
IDX

# SUN ROOF

## D Guide rail assembly

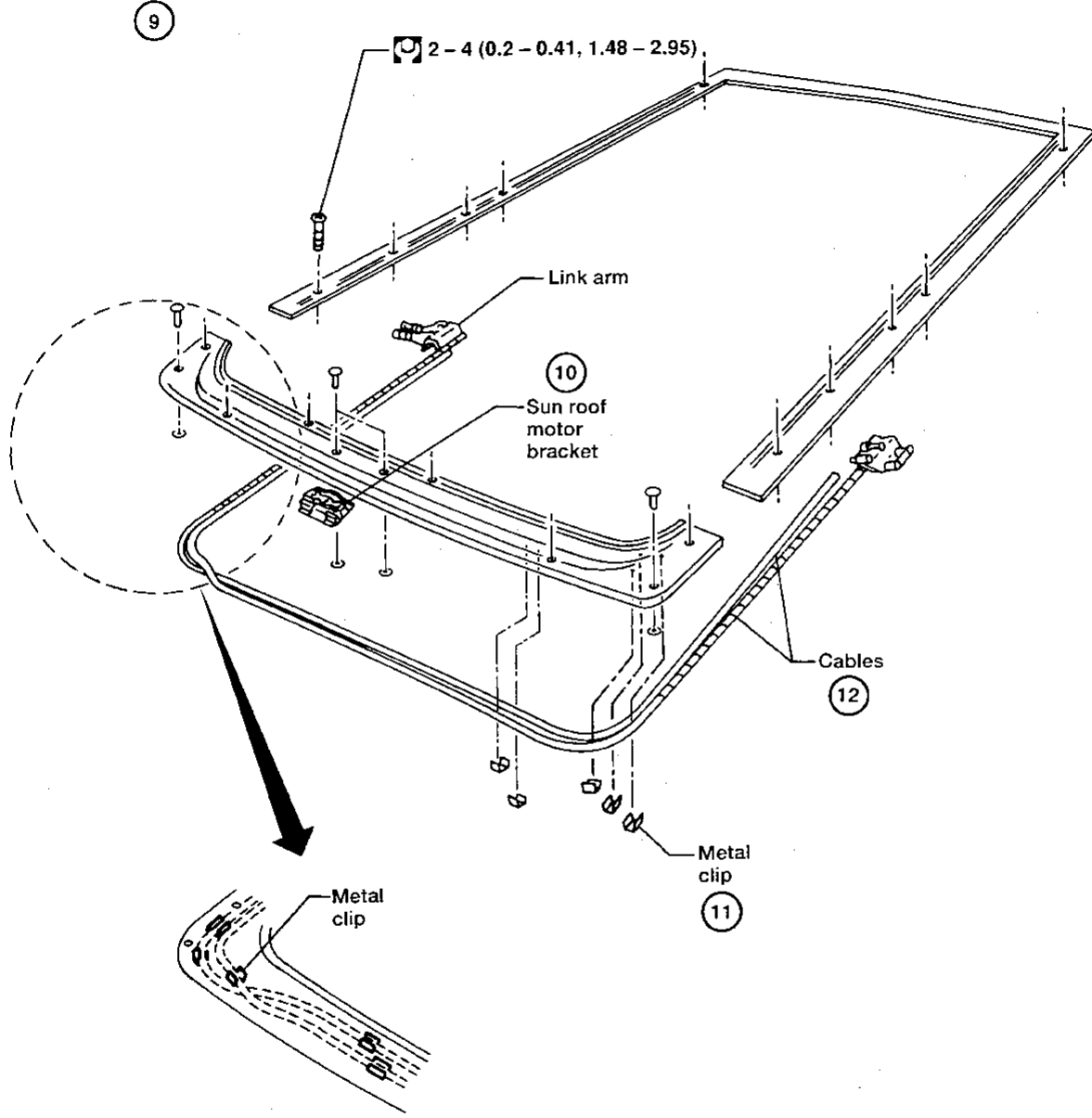



# SUN ROOF

## System Description

The position of the sunroof is controlled by the sunroof switch. The switch allows the sunroof to:

- tilt up and down to provide a rear vent, and
- open and close completely.

GI

Power is supplied at all times:

- through 30A fusible link (No. 13, located in the fusible link box-1)
- to circuit breaker-1 terminal ①
- through circuit breaker-1 terminal ②
- to the power window relay terminal ⑤.

MA

EM

With the ignition switch in the ON or START position, power is supplied:

- through 10A fuse (letter T, located in the fuse block)
- to the power window relay terminal ②.

LC

EF &

EC

Ground is supplied:

- to the power window relay terminal ①
- through the diode junction connector-1 terminal ⑬
- through the diode junction connector-1 terminal ⑮
- through body grounds M5 and M75.

FE

With power and ground supplied, the power window relay is energized, and power is supplied:

- to the sunroof motor assembly terminal ①
- from the power window relay terminal ③.

AT

Ground is supplied:

- to the sunroof motor assembly terminal ②
- through body grounds M5 and M75.

FA

RA

## TILT AND SLIDE OPERATION

A ground signal is sent to the internal control circuitry of the sunroof motor assembly when the sunroof switch is pressed. The motor is activated by the control circuitry. The motor turns off when the switch is released.

BR

The sunroof will slide open when the OPEN side of the switch is pressed. It will slide closed when the CLOSE side of the switch is pressed.

ST

The sunroof must be in the closed position for the tilt feature to operate. The rear of the sunroof will tilt up when the UP side of the switch is pressed. The sunroof will return from the up position to the closed position when the DOWN side of the switch is pressed.

BF

The sun shade opens automatically when the sunroof is opened. It must be closed manually.

HA

EL

IDX

# SUN ROOF

## Wiring Diagram -SROOF-

BF-SROOF-01

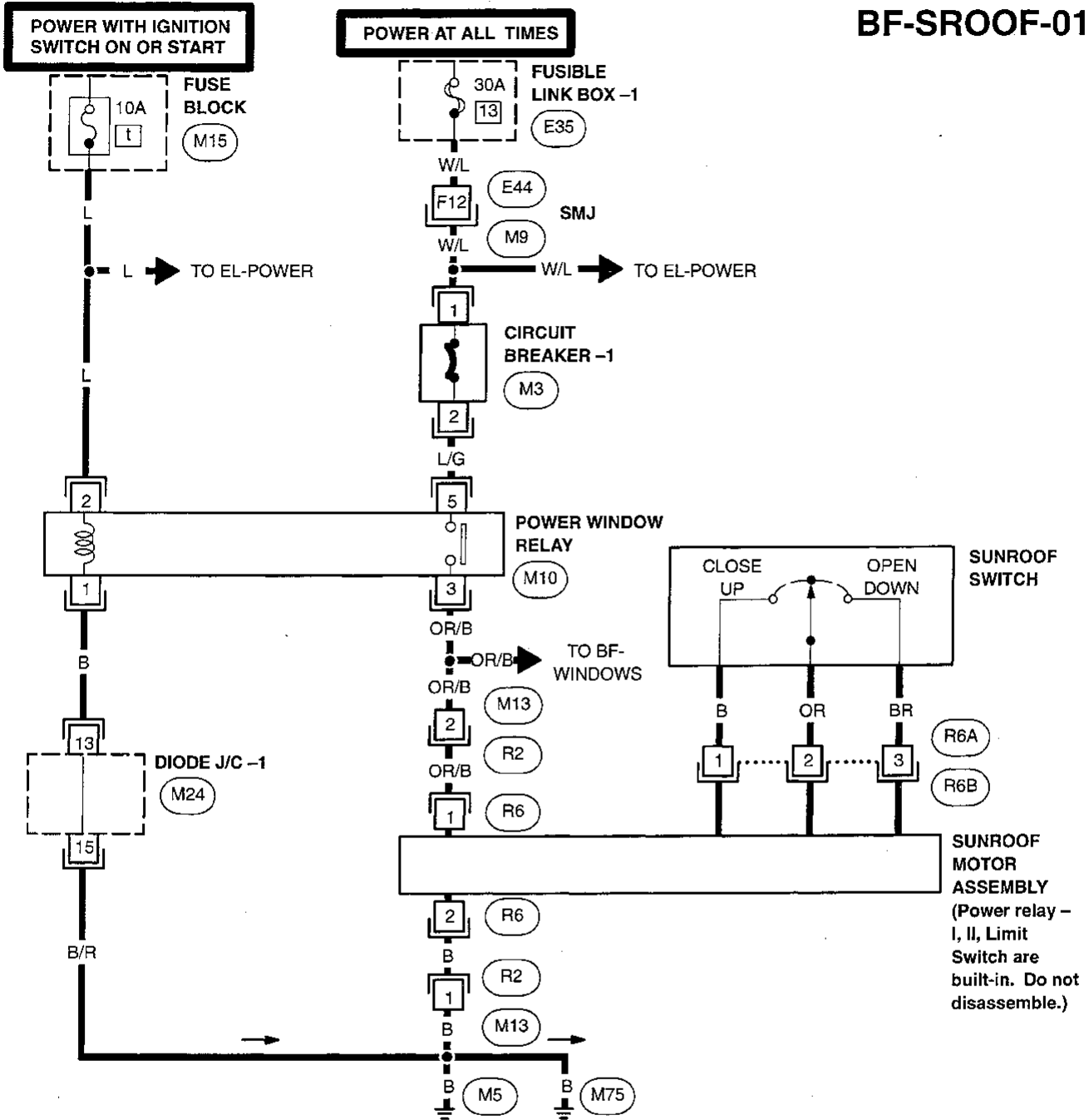

Refer to POWER SUPPLY ROUTING in EL Section. (M15)

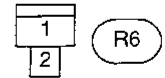
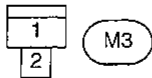

Refer to Foldout Page in EL Section for details. (M24)

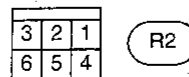
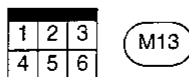
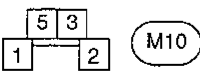

Refer to POWER SUPPLY ROUTING in EL Section. (E35)

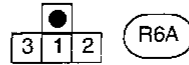
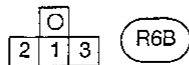

Refer to Foldout Page in EL Section for details. (M9) (E44)

## Windshield/Back Door Window

### REMOVAL

After removing moldings, remove glass.

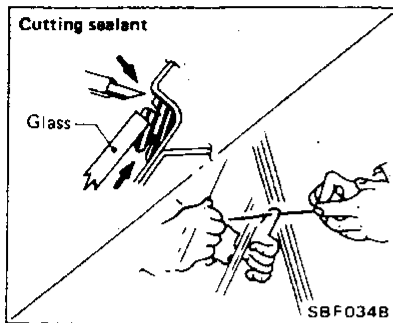

### CAUTION:

Be careful not to scratch glass when removing.

### INSTALLATION

- Use genuine Nissan Sealant kit or equivalent. Follow instructions furnished with it.
- After installation, the vehicle should remain stationary for about 24 hours.

### WARNING:

Keep heat or open flames away as primers are flammable.

### CAUTION:

Advise the user of the fact that vehicle should not be driven on rough roads or surfaces until sealant has properly vulcanized.

- Do not use sealant which is past its usable term.
- Keep primers and sealant in a cool, dry place. Ideally, they should be stored in a refrigerator.
- Windshield glass should be installed within 15 minutes of applying sealant: sealant starts to harden 15 minutes after it is applied.
- Molding must be installed securely so that it is in position and leaves no gap.

GI  
MA  
EM  
LC  
EF & EC  
FE  
AT  
FA  
RA  
BR  
ST  
BF  
HA  
EL  
IDX

Body side

Install spacer to panel

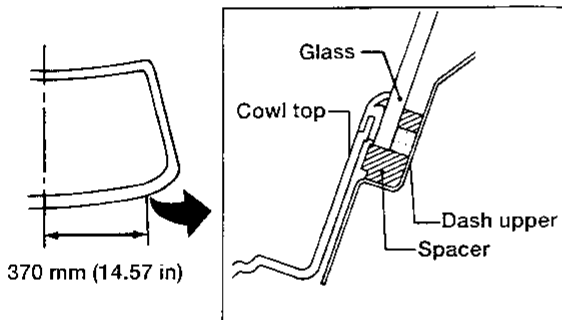

Install molding fastener.

When installing it, heat body panel and fastener to approx. 30 to 40°C (86 to 104°F).

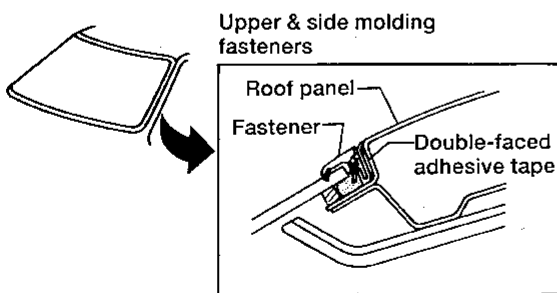

Glass side

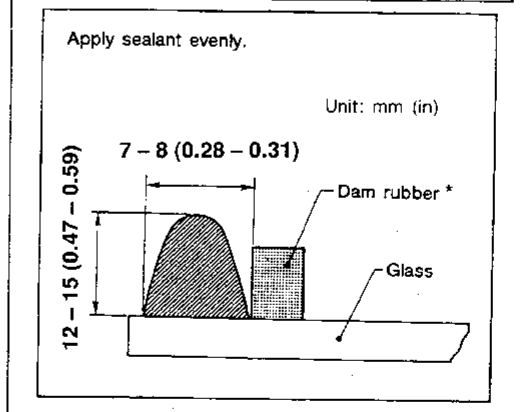
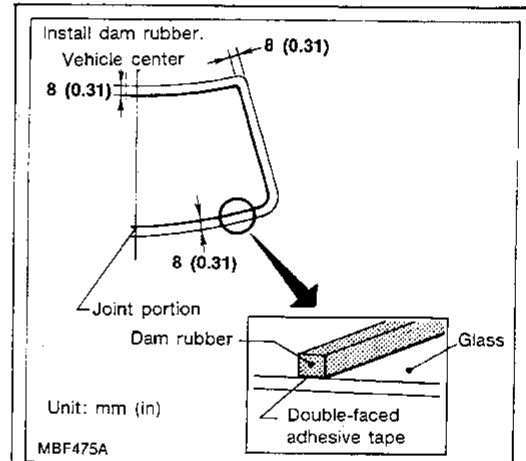

ABF275

### REPAIRING WATER LEAKS

Leaks can be repaired without removing and reinstalling glass.

**If water is leaking between caulking material and body or between glass and caulking material, determine the extent of the leak by applying water while pushing glass outward.**

To stop the leak, apply primer (if necessary) and then sealant to the leak point.

\* Back door window does not use dam rubber.

# WINDSHIELD AND WINDOWS

## Side Window (1st)

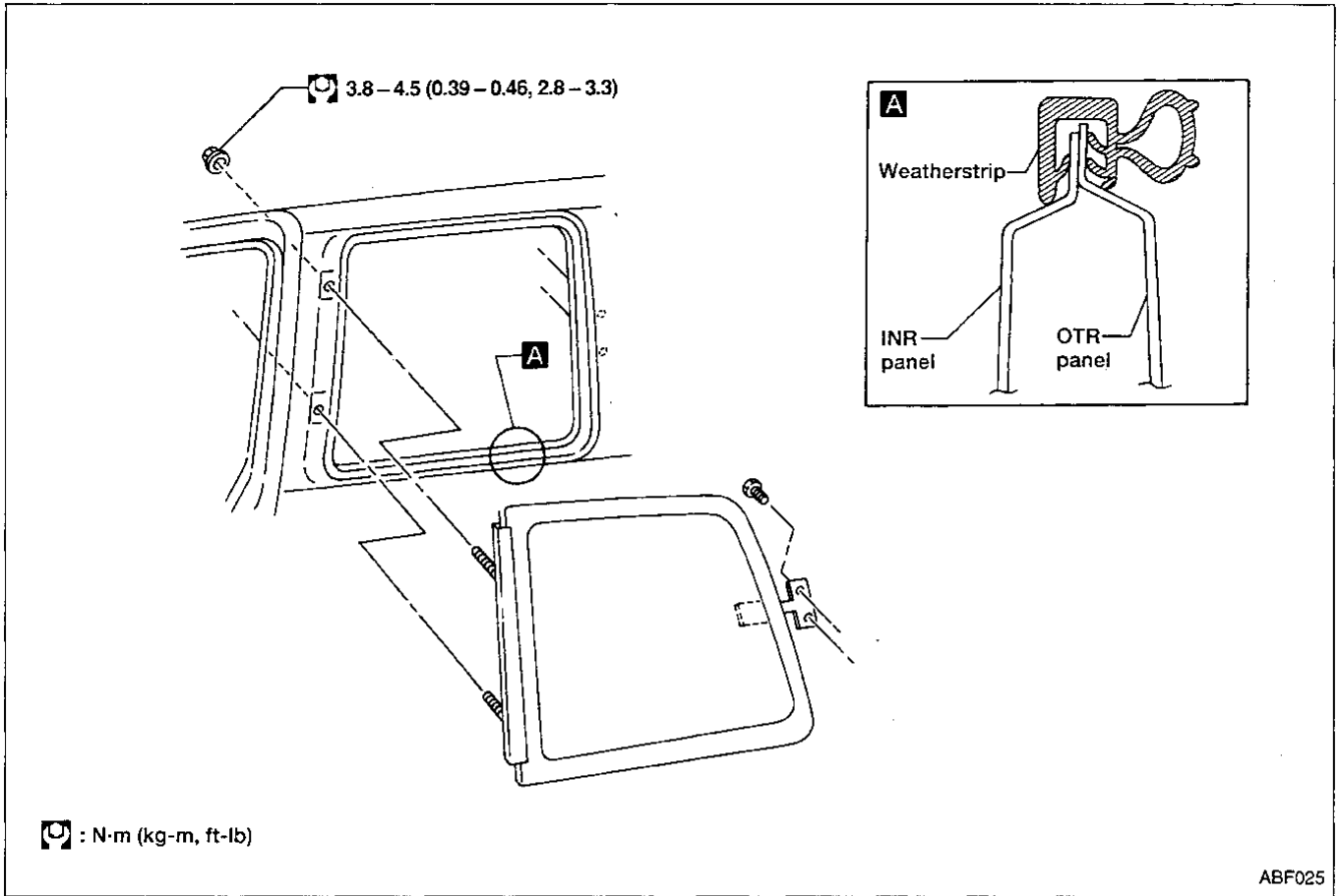

# WINDSHIELD AND WINDOWS

## Side Window (2nd)

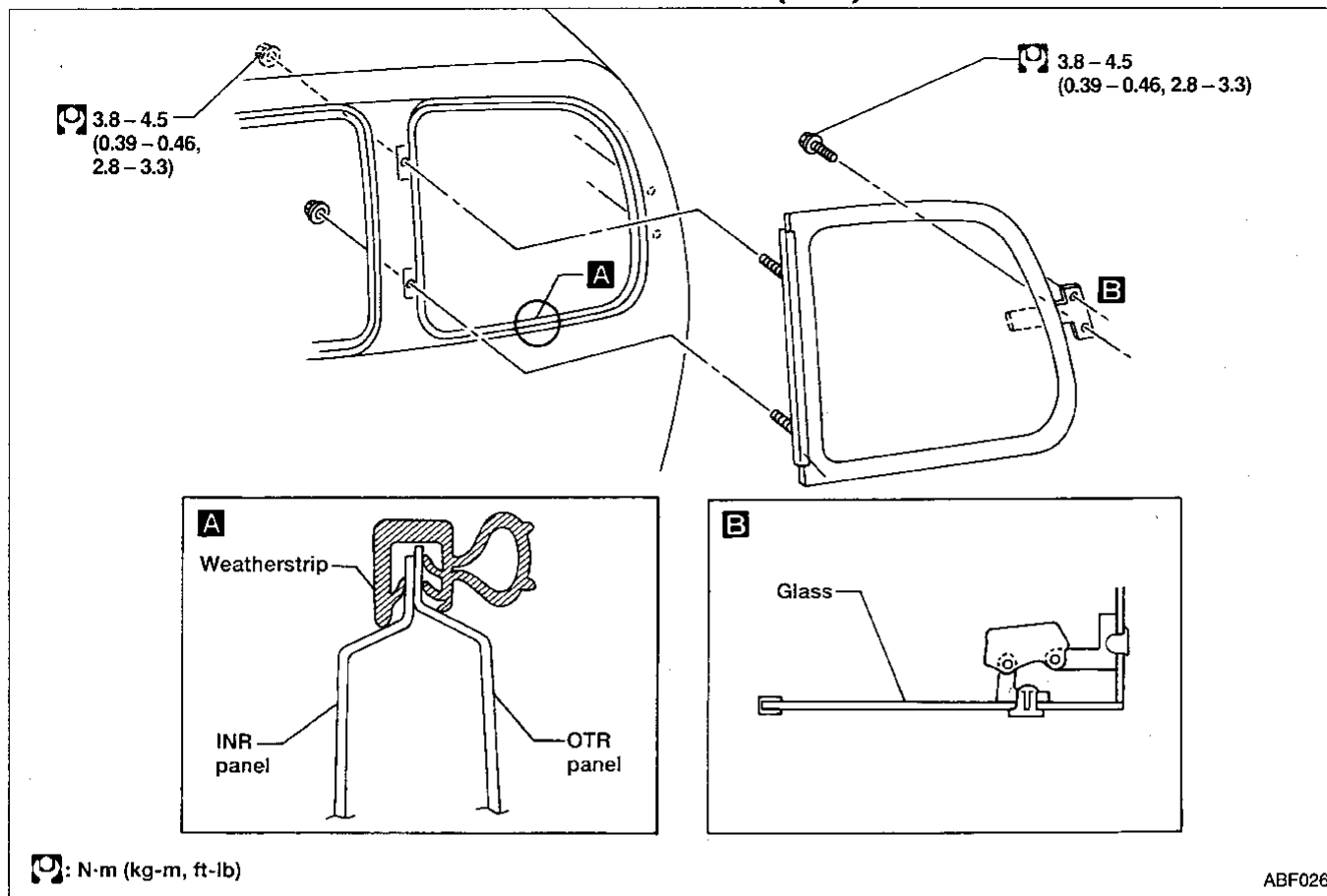

### INSTALLATION

1. Electrically place the cable in the open position.
2. Attach the mechanism to the glass and tighten the attaching screw.
3. Loosely attach mechanism to body with bolts.
  - **Do not tighten the bolts.**
4. Electronically place window to closed position.
5. From outside vehicle, push on glass at attaching point.
6. Tighten bolts.
7. Check operation.

### CAUTION:

Failure to follow this procedure may cause damage to control and wire assembly.

GI  
MA  
EM  
LC  
EF &  
EC  
FE  
AT  
FA  
RA  
BR  
ST  
BF  
HA  
EL  
IDX

# MIRROR

## Door Mirror

### REMOVAL

- Warm the door mirror to approximately 70°C (159°F) for three minutes.
- Carefully pry door mirror glass from door mirror glass frame with a stiff blade scraper.

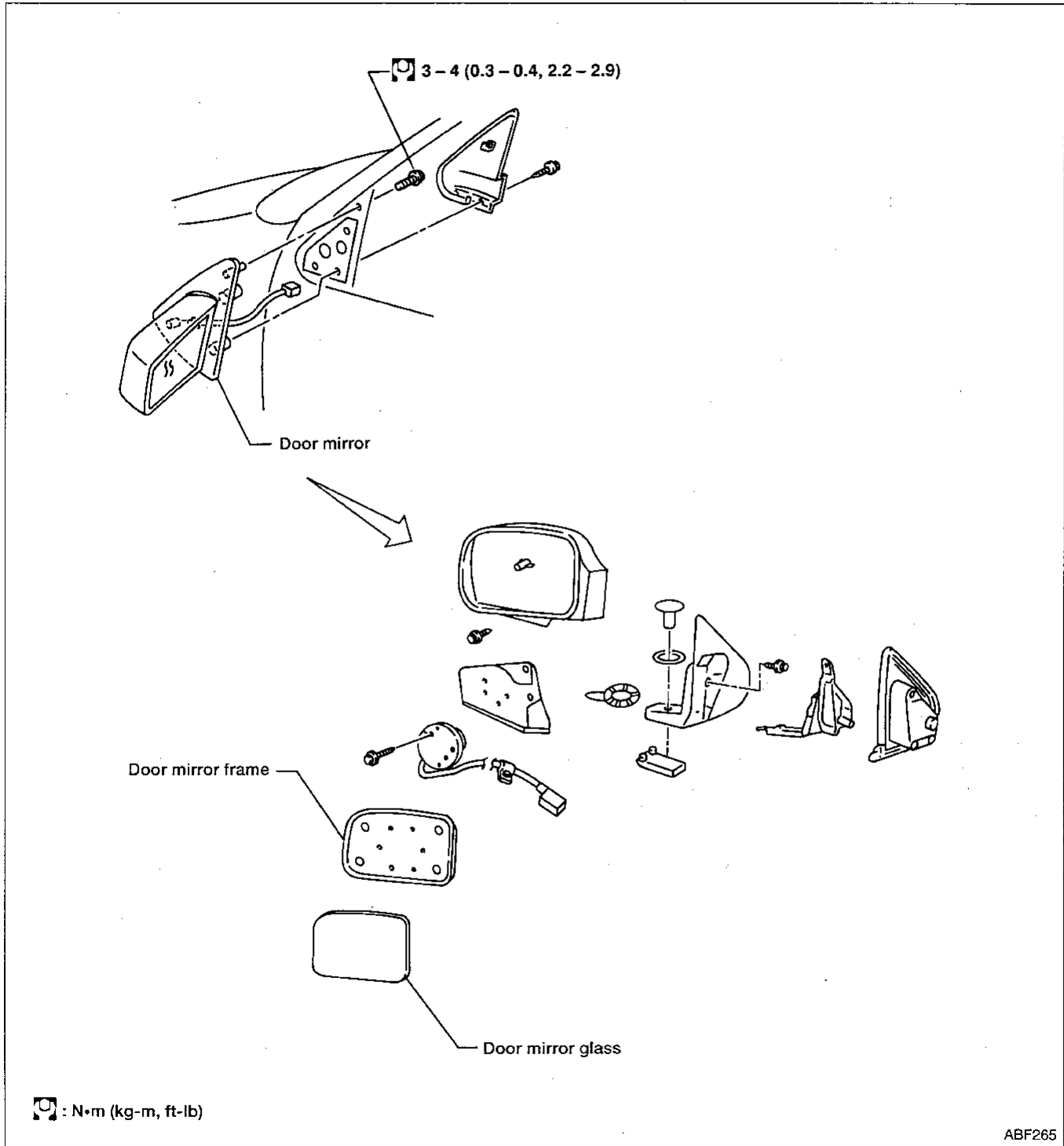

# MIRROR

## Wiring Diagram -MIRROR-

BF-MIRROR-01 GI

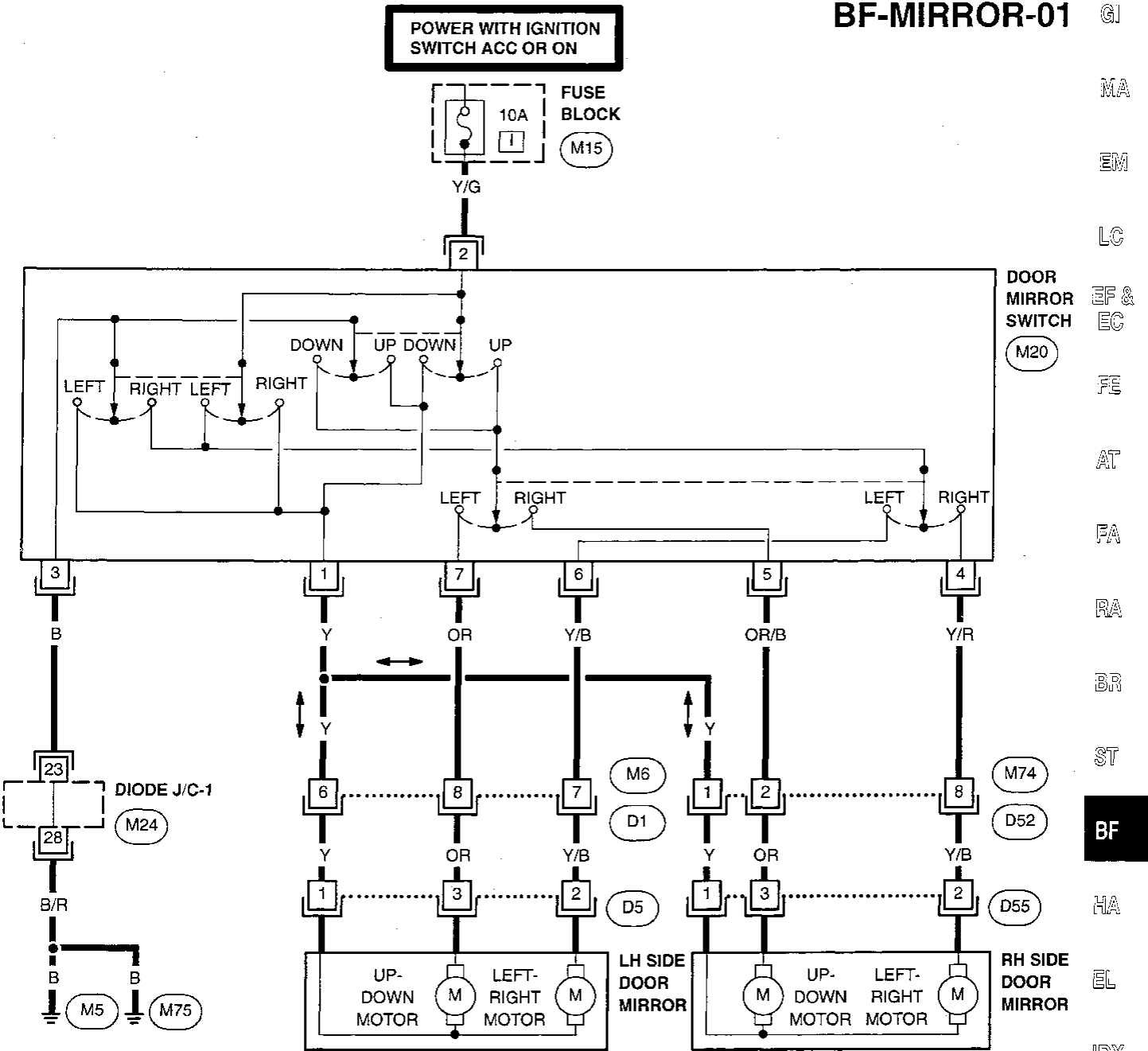

Refer to POWER SUPPLY ROUTING in EL Section. (M15)

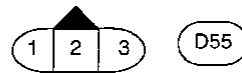
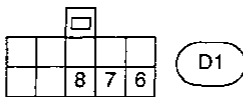
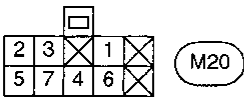
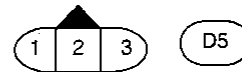
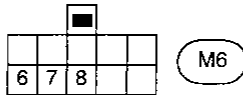

Refer to Foldout Page in EL Section for details. (M24)

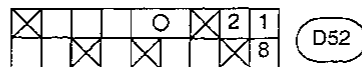
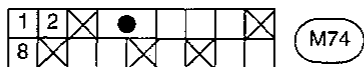

ABF225

# MIRROR

## Rearview Mirror

### REMOVAL

Remove rearview mirror by pushing deflect spring with screwdriver as shown in the figure.

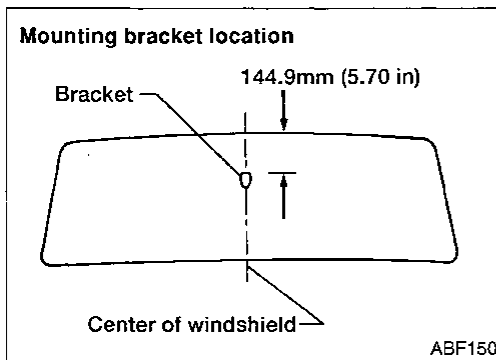
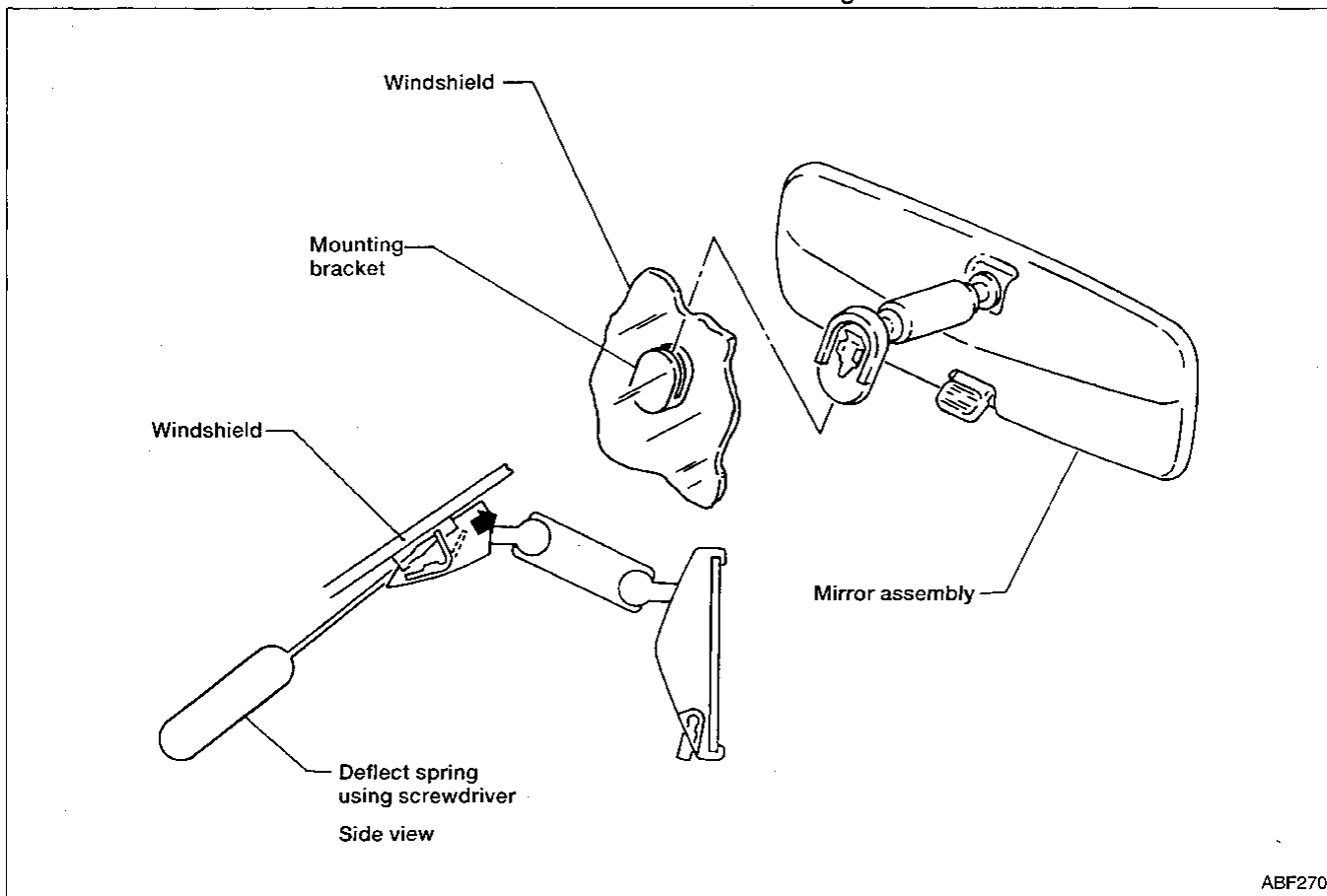

### INSTALLATION

1. Install mounting bracket as follows:
  - (1) Determine mounting bracket position on windshield by measuring from top of windshield to top of mounting bracket as shown in the figure.
  - (2) Mark location on outside of windshield with wax pencil or equivalent.
  - (3) Clean attaching point on inside of windshield with an alcohol-saturated paper towel.
  - (4) Sand bonding surface of mounting bracket with sandpaper (No. 320 or No. 360).
  - (5) Clean bonding surface of mounting bracket with an alcohol-saturated paper towel.
  - (6) Apply Loctite Adhesive 11067-2 or equivalent to bonding surface of mounting bracket.
  - (7) Install mounting bracket at premarked position and press mounting bracket against glass for 30 to 60 seconds.
  - (8) After five minutes, wipe off excess adhesive with an alcohol-moistened paper towel.
2. Install rearview mirror.



# BODY ALIGNMENT

- All dimensions indicated in figures are actual ones.
- When a tram tracking gauge is used, adjust both pointers to equal length and check the pointers and gauge itself to make sure there is no free play.
- When a measuring tape is used, check to be sure there is no elongation, twisting or bending.
- Measurements should be taken at the center of the mounting holes.
- An asterisk (\*) following the value at the measuring point indicates that the measuring point on the other side is symmetrically the same value.
- The coordinates of the measurement points are the distances measured from the standard line of "X", "Y" and "Z".

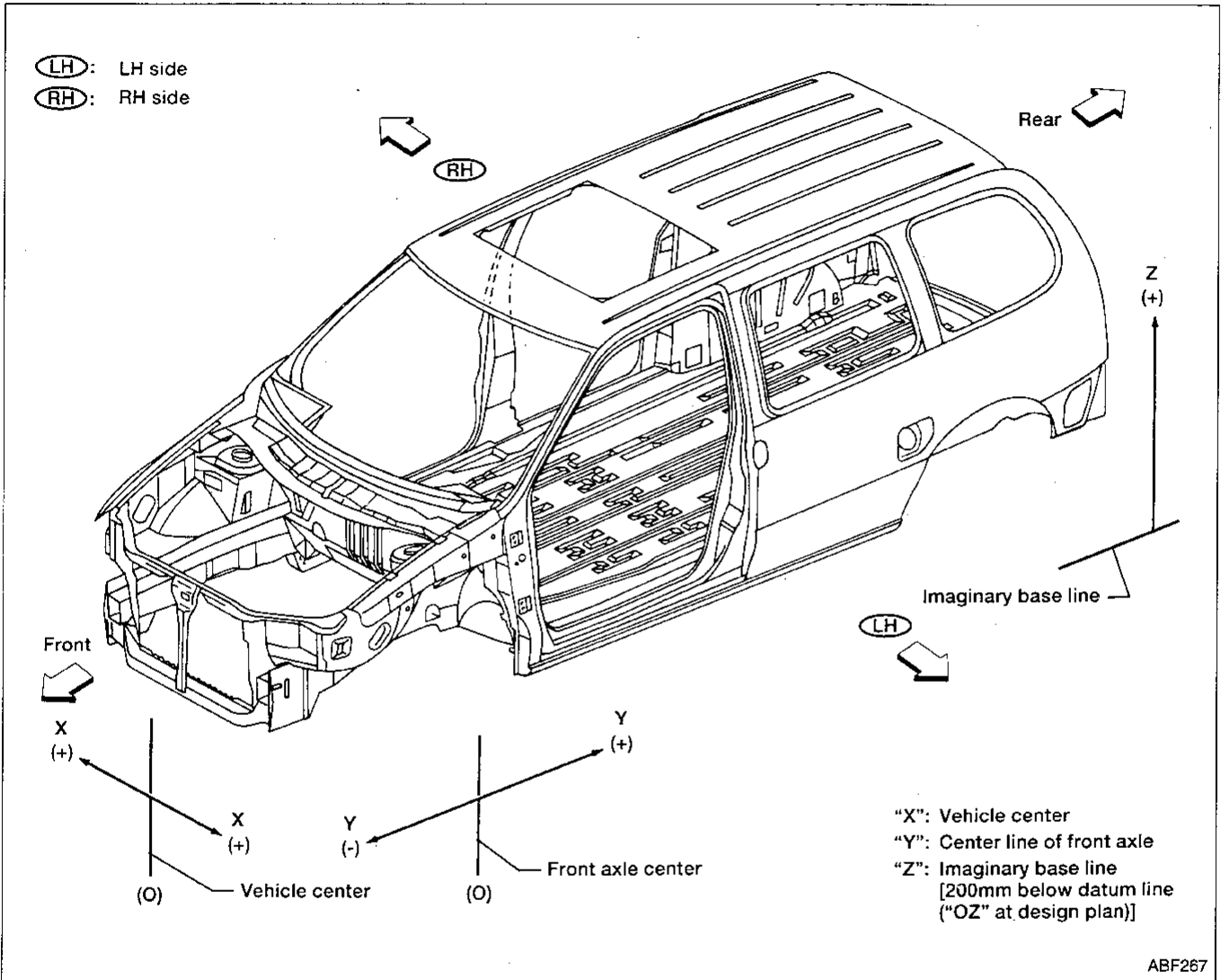

GI  
 MA  
 EM  
 LC  
 EF &  
 EC  
 FE  
 AT  
 FA  
 RA  
 BR  
 ST  
**BF**  
 HA  
 EL  
 IDX

# BODY ALIGNMENT

## Engine Compartment

### MEASUREMENT

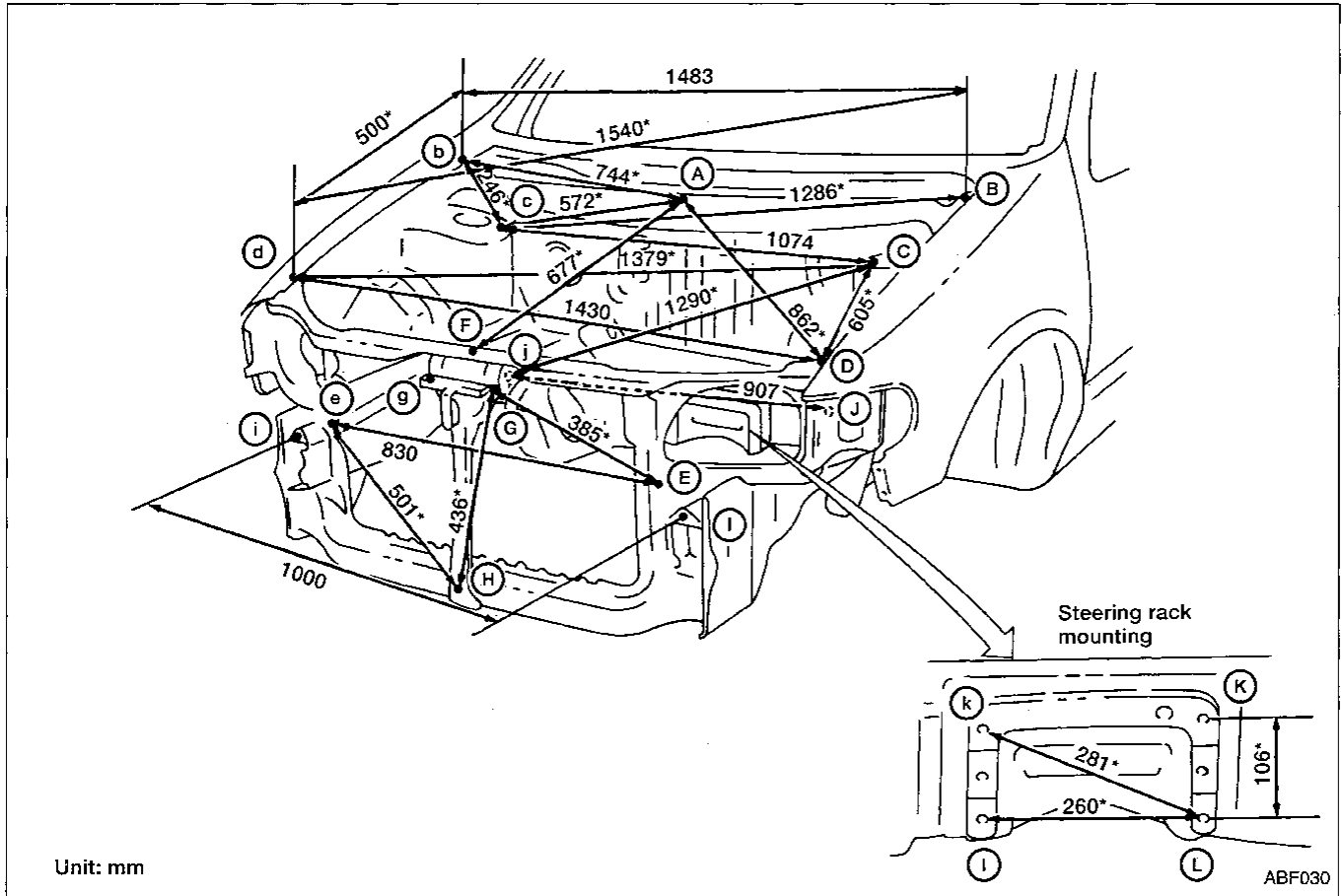

# BODY ALIGNMENT

## Engine Compartment (Cont'd)

### MEASUREMENT POINTS

Unit: mm

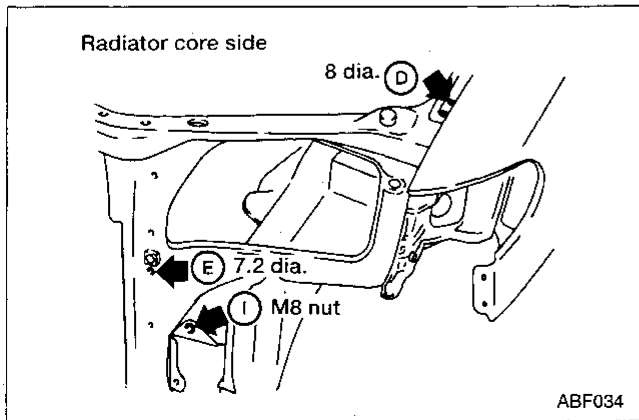
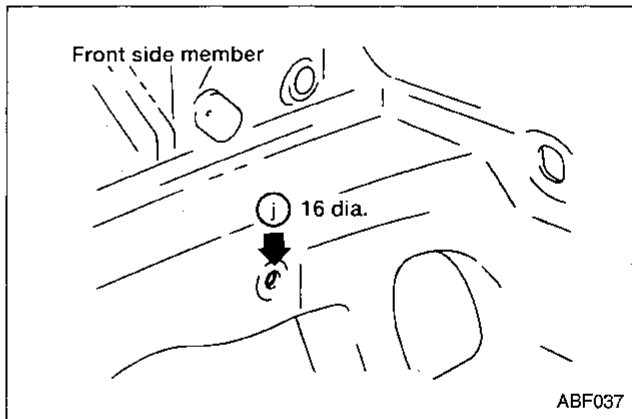
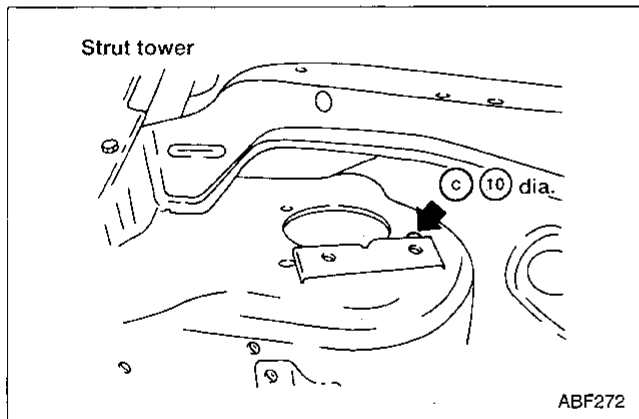
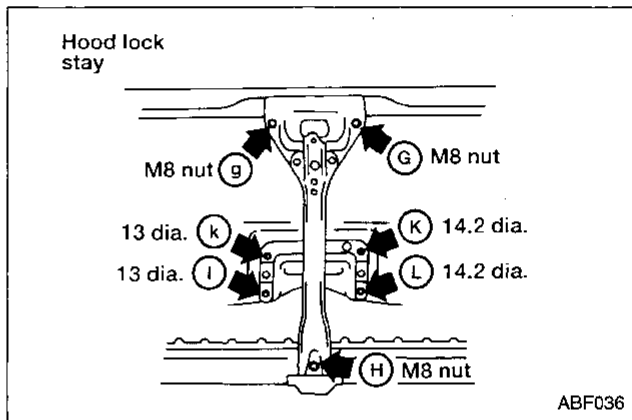
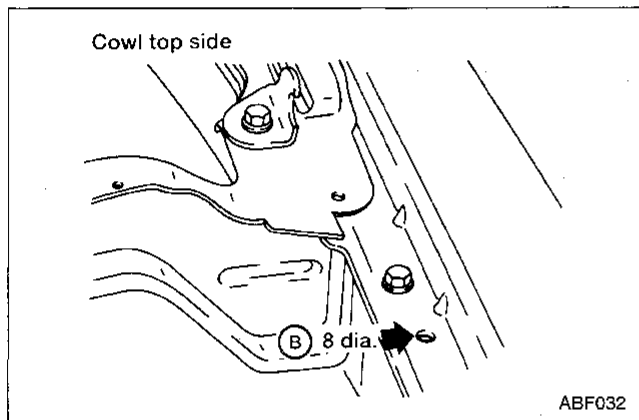
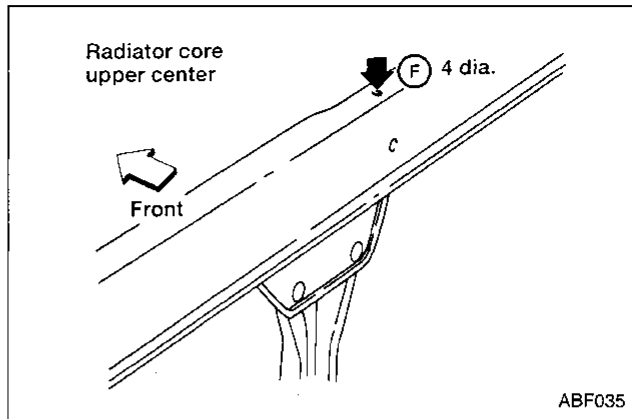
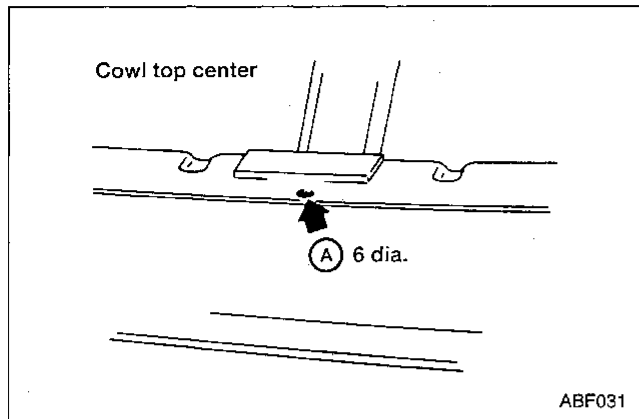

GI

MA

EM

LC

EF &

EC

FE

AT

FA

RA

BR

ST

**BF**

HA

EL

IDX

# BODY ALIGNMENT

## MEASUREMENT

### Underbody

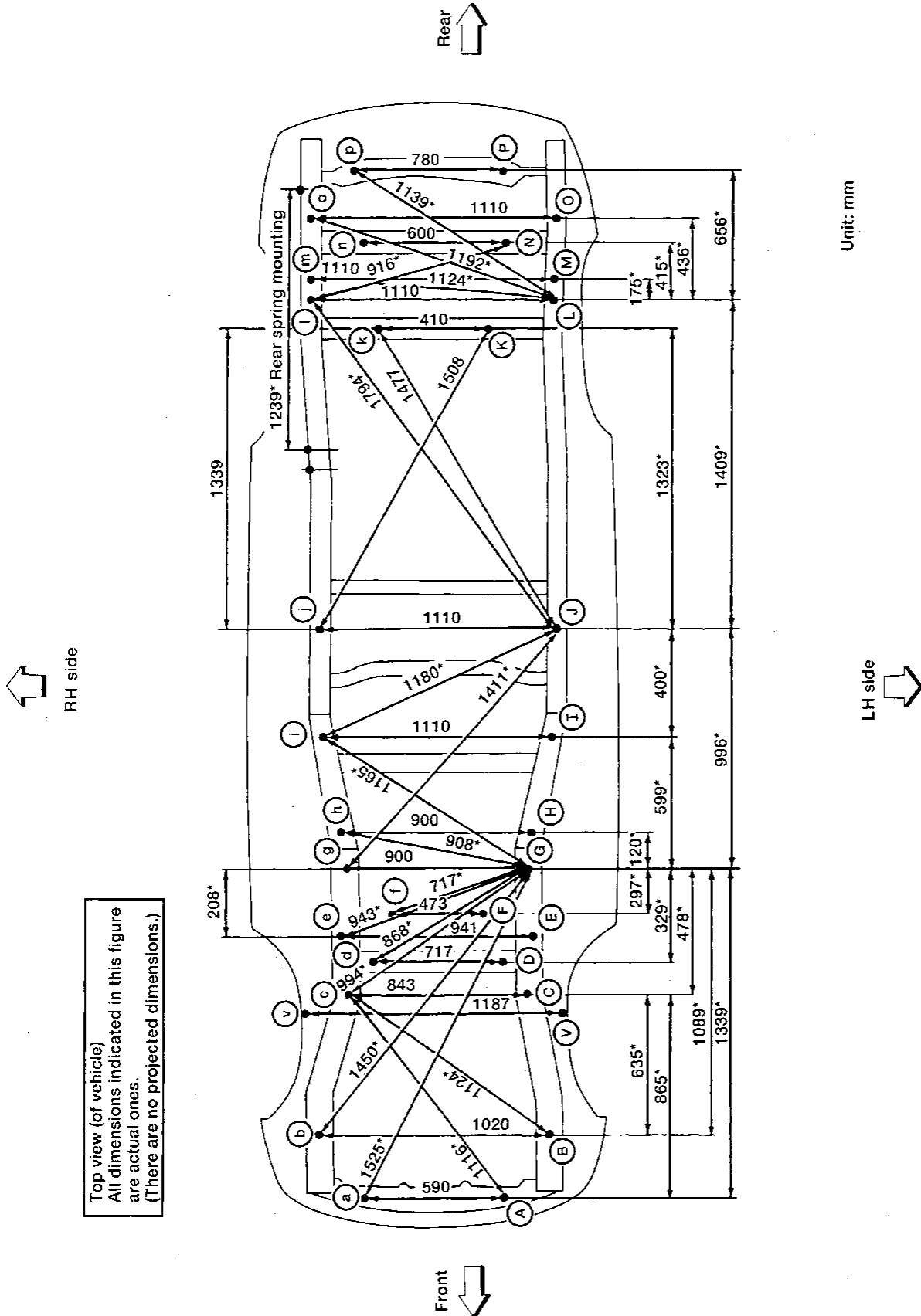

# BODY ALIGNMENT

## Underbody (Cont'd)

### MEASUREMENT POINTS

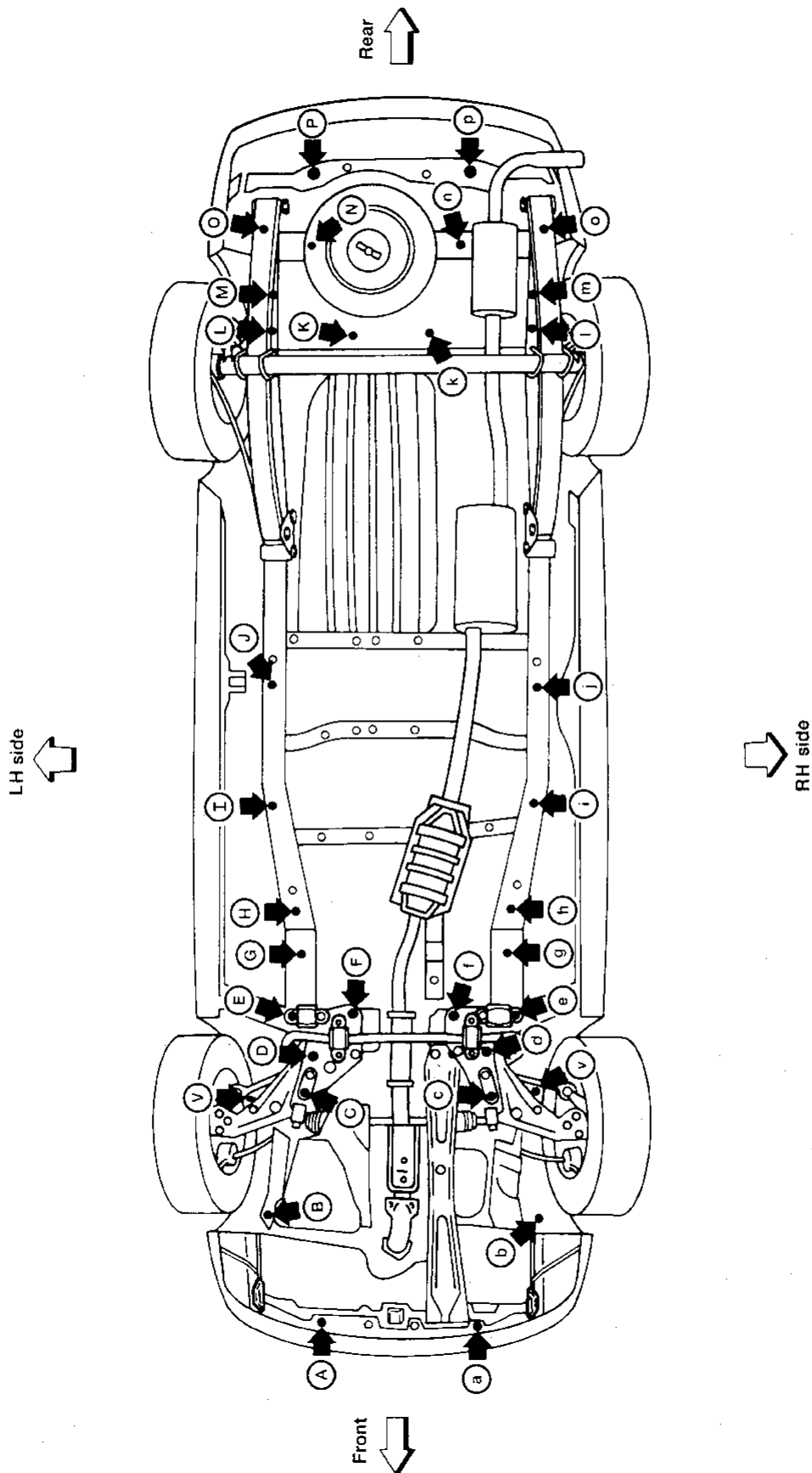

- GI
- MA
- EM
- LC
- EF & EC
- FE
- AT
- FA
- RA
- BR
- ST
- BF**
- HA
- EL
- IDX

# BODY ALIGNMENT

## Underbody (Cont'd)

### Front side member and front extension

Coordinates:

(A), (a)	X: 295
	Y: -750
	Z: 168.8
(B), (b)	X: 510
	Y: -500
	Z: 310
(C), (c)	X: 421.5
	Y: 105
	Z: 137.7
(D), (d)	X: 358.5
	Y: 264.4
	Z: 170.5
(E), (e)	X: 470.5
	Y: 373.3
	Z: 182.2
(F), (f)	X: 236.5
	Y: 373.3
	Z: 182.2
(G), (g)	X: 450
	Y: 580
	Z: 186.5
(H), (h)	X: 450
	Y: 700
	Z: 186.5
(I), (i)	X: 555
	Y: 1170
	Z: 182
(J), (j)	X: 555
	Y: 1570
	Z: 199.7

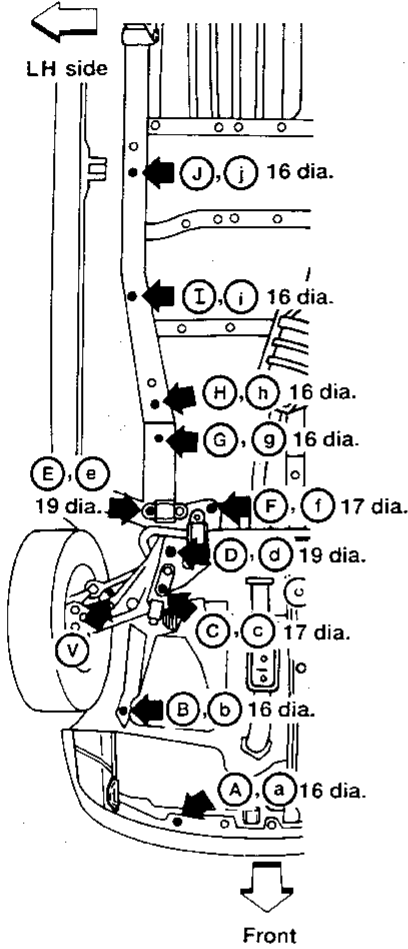

### Center side member and rear extension

Coordinates:

(K)	X: 235
	Y: 2850
	Z: 303.8
(k)	X: 175
	Y: 2850
	Z: 303.8
(L), (l)	X: 555
	Y: 2975
	Z: 307
(M), (m)	X: 555
	Y: 3150
	Z: 315.1
(N), (n)	X: 300
	Y: 3300
	Z: 347.5
(O), (o)	X: 555
	Y: 3410
	Z: 328.1
(P), (p)	X: 390
	Y: 3610
	Z: 295.6

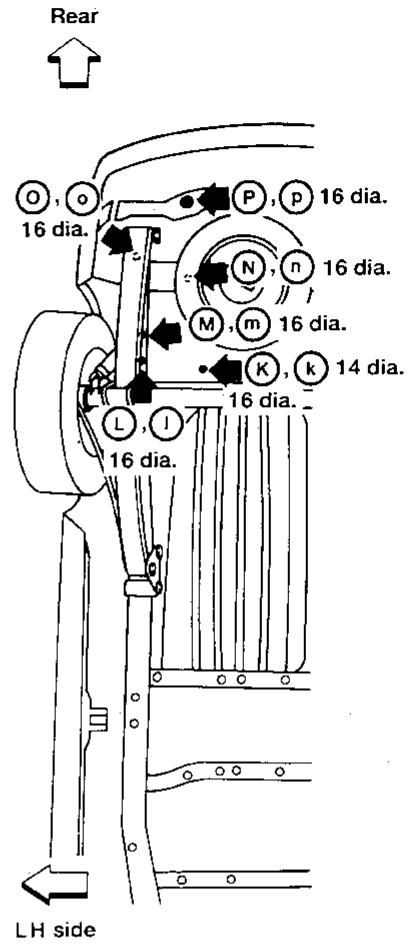

### Front strut tower centers

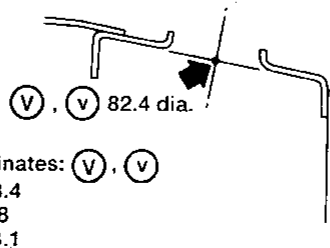

# SUPPLEMENTAL RESTRAINT SYSTEM (SRS)

## Precautions for SRS Supplemental "Air Bag" Service

- Do not use a circuit tester to check SRS circuits.
- Before servicing the SRS, turn ignition switch "OFF", disconnect battery ground cable and wait for at least 10 minutes.  
For approximately ten minutes after the cables are removed, it is still possible for the supplemental air bag to inflate. Therefore, do not work on any supplemental air bag system connectors or wires until at least ten minutes have passed.
- SRS sensors must always be installed with their arrow marks "↗" facing the front of the vehicle for proper operation. Also check sensors for cracks, deformities or rust before installation and replace as required.
- The spiral cable must be aligned with the neutral position since its rotations are limited. Do not attempt to turn steering wheel or column after removal of steering gear.
- Handle supplemental air bag module carefully. Always place it with the pad side facing upward.
- After removing any SRS parts, discard old bolts and replace with new ones. Conduct self-diagnosis to check entire SRS for proper function.
- If front of vehicle is damaged in a collision, always check the crash zone sensor and the wiring harness.

GI  
WA  
EM  
LC  
EF &  
EC  
FE

## Special Service Tools

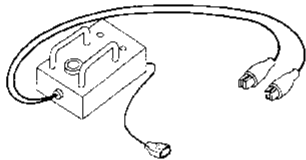
Tool number (Kent-Moore No.) Tool name	Description	
KV99106400 (J38381) Deployment tool		Disposing of supplemental air bag module

AT  
FA  
RA  
BR

## Commercial Service Tools

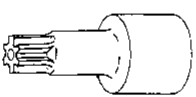
Tool name	Description	
Special torx bit		Use for special bolts (tamper resistant screw)

ST  
BF  
HA

EL  
IDX

# SUPPLEMENTAL RESTRAINT SYSTEM (SRS)

## Description

The supplemental air bag deploys when any of the two sensors (front crash zone sensor or tunnel sensor) and the safing sensor simultaneously activate while the ignition switch is "ON".

Ignition	Crash zone sensor		Tunnel sensor	Safing sensor	Supplemental air bag signal
	Front				
ON	ON			ON	ON
ON			ON	ON	ON

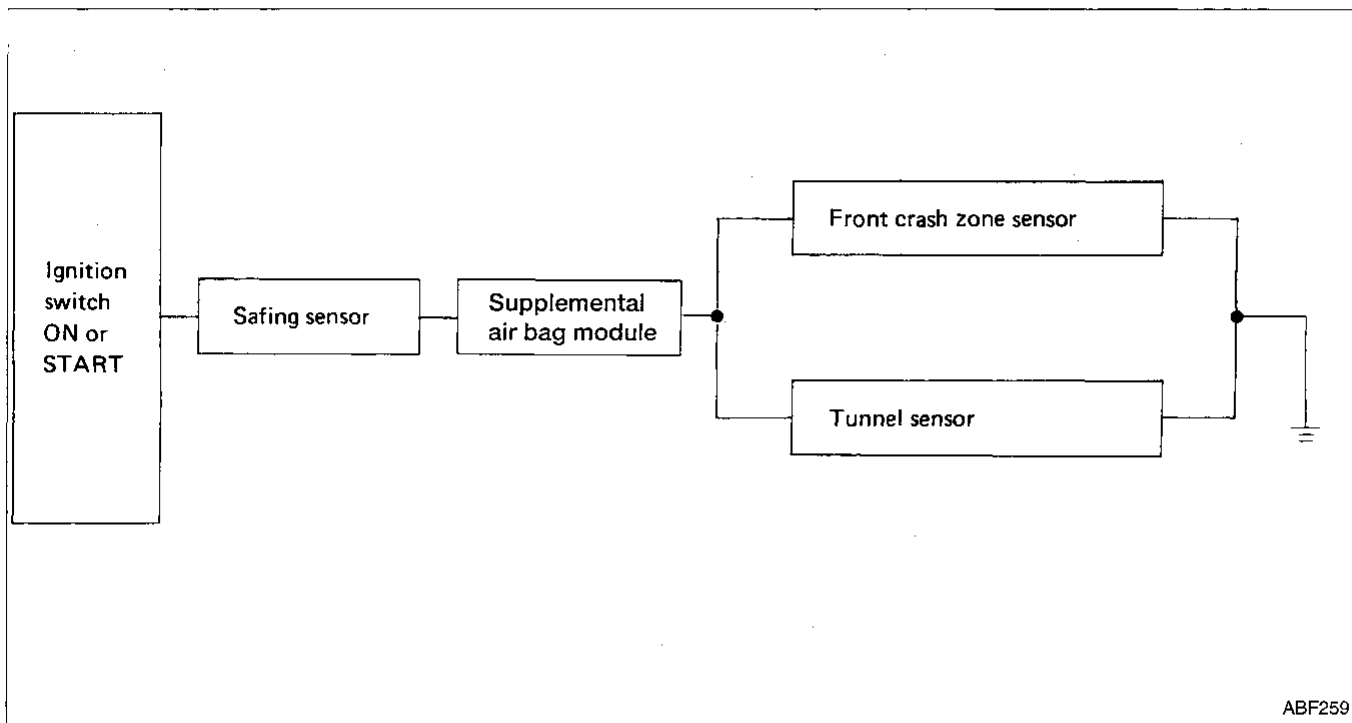

ABF259

## Self-diagnosis

The diagnosis (control) unit diagnoses the SRS circuit. When the ignition key is in the "ON" or "START" position, the supplemental "AIR BAG" warning lamp will illuminate for about 7 seconds and then turn off. This means that the system is operational.



# SUPPLEMENTAL RESTRAINT SYSTEM (SRS)

## SRS Component Parts Location and Caution Labels

The CAUTION LABELS are important when servicing the supplemental air bag in the field. If they are dirty or damaged, replace them with new ones.

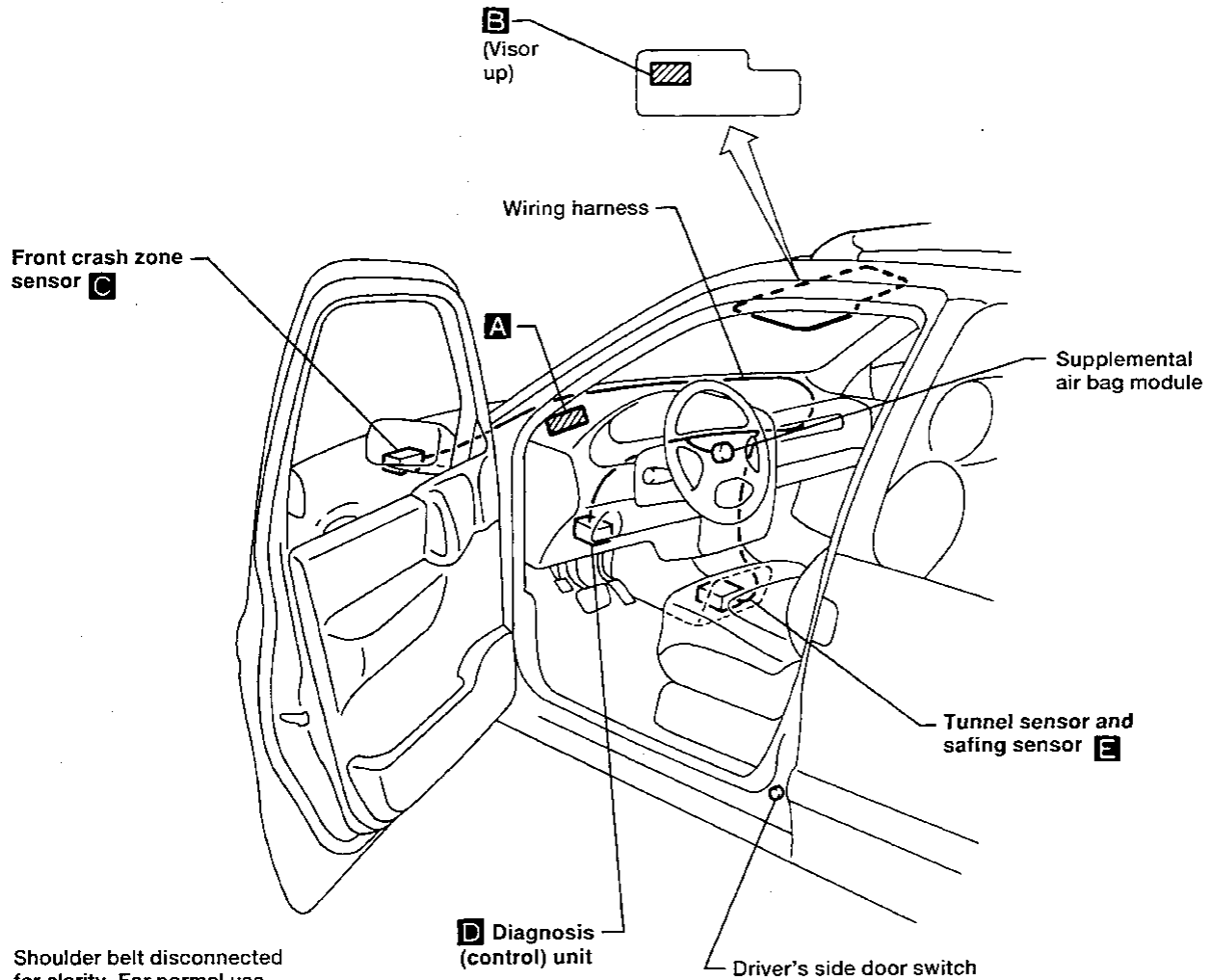

Shoulder belt disconnected for clarity. For normal use, the shoulder belt should always be connected to the buckle.

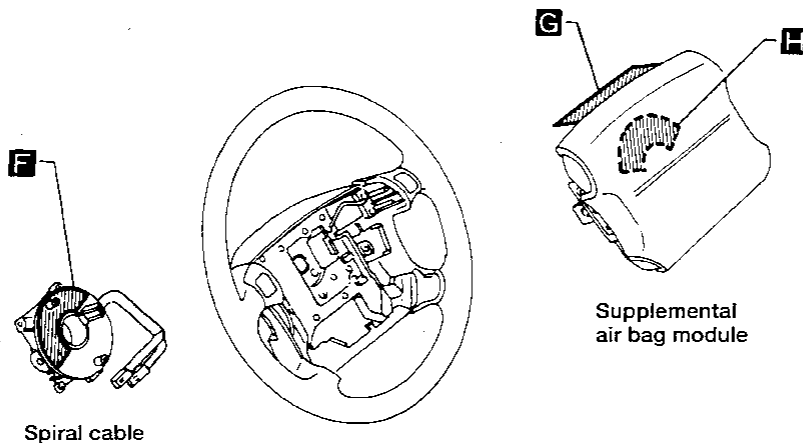

GI  
MA  
EM  
LC  
EF &  
EC  
FE  
AT  
FA  
RA  
BR  
ST  
BF  
HA  
EL  
IDX

# SUPPLEMENTAL RESTRAINT SYSTEM (SRS)

## Caution Labels

**A**

DRIVER-AIRBAG

**B**

CAUTION SRS AIRBAG

- THIS CAR HAS A DRIVER'S SIDE AIR BAG AS A SUPPLEMENTAL RESTRAINT SYSTEM (SRS) TO HELP PROTECT DRIVER IN A MODERATE OR SEVERE FRONTAL COLLISION.
- ALWAYS WEAR YOUR AUTOMATIC BELT AND MANUAL LAP BELT. THE AIR BAG IS NOT DESIGNED TO INFLATE IN MANY KINDS OF ACCIDENTS. THE AIR BAG IS NOT A SUBSTITUTE FOR SEAT BELTS.
- SEVERE INJURIES COULD OCCUR IF YOU ARE AGAINST AIR BAG WHEN IT INFLATES. SIT BACK AND UPRIGHT IN THE SEAT AND WEAR YOUR BELTS.
- THE SYSTEM MUST BE INSPECTED 10 YEARS AFTER DATE OF MANUFACTURE SHOWN ON THE CERTIFICATION LABEL ON LEFT FRONT DOOR PILLAR. THE SYSTEM MUST BE SERVICED IF THE "AIR BAG" LAMP DOES NOT GO ON, FLASHES INTERMITTENTLY OR REMAINS ON.
- SEE OWNER'S MANUAL FOR ADDITIONAL SAFETY INFORMATION.

**C**

WARNING SRS AIRBAG

- DO NOT DISASSEMBLE OR TAMPER.
- DISMANTLING AND INSTALLATION SHOULD ONLY BE PERFORMED BY TRAINED PERSONNEL.

**D**

CAUTION SRS AIRBAG

- NO SERVICEABLE PARTS INSIDE.
- DO NOT DISASSEMBLE OR TAMPER.
- DO NOT DROP; KEEP DRY.
- WHILE REMOVED, STORE IN A CLEAN AND DRY AREA.
- IF WET CONDITION OCCURS, THIS UNIT MUST BE SERVICED.

**E**

WARNING SRS AIRBAG

- DO NOT DISASSEMBLE OR TAMPER.
- DISMANTLING AND INSTALLATION SHOULD ONLY BE PERFORMED BY TRAINED PERSONNEL.

**F**

CAUTION SRS AIRBAG

- BEFORE REMOVAL AND INSTALLATION ALIGN FRONT WHEELS STRAIGHT AHEAD.
- READ SERVICE MANUAL.
- NO SERVICEABLE PARTS INSIDE.
- TO RE-CENTER ROTATE IN DIRECTION OF ARROW ← UNTIL TIGHT THEN ROTATE IN OPPOSITE DIRECTION 3 TURNS.

# SUPPLEMENTAL RESTRAINT SYSTEM (SRS)

## Caution Labels (Cont'd)

**G**

WARNING	SRS AIRBAG
<ul style="list-style-type: none"><li>● THIS AIR BAG MODULE CANNOT BE REPAIRED.</li><li>● USE DIAGNOSTIC INSTRUCTIONS TO DETERMINE IF THE UNIT IS OPERATIONAL.</li><li>● IF NOT OPERATIONAL, REPLACE AND DISPOSE OF THE ENTIRE UNIT AS DIRECTED IN THE INSTRUCTIONS.</li><li>● UNDER NO CIRCUMSTANCES SHOULD A DIAGNOSIS BE PERFORMED USING ELECTRICALLY POWERED TEST EQUIPMENT OR PROBING DEVICES.</li><li>● TAMPERING OR MISHANDLING CAN RESULT IN PERSONAL INJURY.</li><li>● STORE THE REMOVED AIR BAG MODULE WITH THE PAD SURFACE UP.</li><li>● FOR SPECIAL HANDLING OR STORAGE REFER TO SERVICE MANUAL.</li></ul>	

**H**

DANGER
CONTENTS ARE POISONOUS AND EXTREMELY FLAMMABLE. DO NOT DISMANTLE, INCINERATE OR BRING INTO CONTACT WITH ELECTRICITY OR STORE AT TEMPERATURES EXCEEDING 200°F.

GI

MA

EM

LC

EF &  
EC

FE

AT

FA

RA

BR

ST

**BF**

HA

EL

IDX

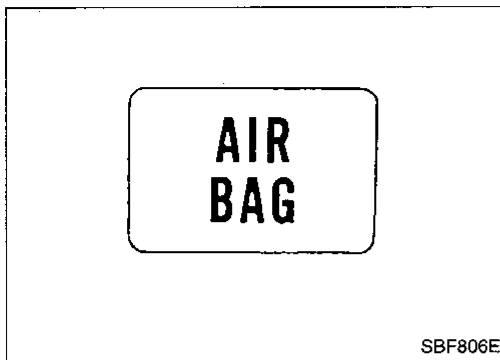

## Maintenance Items

1. Check supplemental "AIR BAG" warning lamp  
When the ignition key is in the "ON" or "START" position, the supplemental "AIR BAG" warning lamp will illuminate for about 7 seconds and then turn off. This means that the system is operational. When a warning lamp flashes, check and correct cause of the problem. Refer to BF-121.
2. Visually check SRS components
  - (1) Sensors
    - Check sensors to ensure the arrow marks face the front of the vehicle.
    - Check body and sensor brackets for deformities or rust.
    - Check sensor case for dents, cracks, deformities or rust.
    - Check sensor harness for binding, connector for damage, and terminals for deformities.
  - (2) Diagnosis (control) unit — Supplemental air bag
    - Check case and bracket for dents, cracks or deformities.
    - Check connectors for damage, and terminals for deformities.
  - (3) Main harness and instrument harness
    - Check connectors for poor connections.
    - Check harnesses for binding, connectors for damage, and terminals for deformities.
  - (4) Spiral cable
    - Visually check lock (engagement) pins and combination switch for damage.
    - Check connectors, flat cable and protective tape for damage.
    - Check steering wheel for noise, binding or difficult operation.
  - (5) Steering wheel
    - Check harness (built into steering wheel) and connectors for damage, and terminals for deformities.
    - Install supplemental air bag module to check fit or alignment with steering wheel.
    - Check steering wheel for excessive free play.
  - (6) Supplemental air bag module
    - Remove supplemental air bag module from steering wheel. Check harness cover and connectors for damage, terminals for deformities, and harness for binding.
    - Install supplemental air bag module to steering wheel to check fit or alignment with the wheel.

### CAUTION:

Replace previously used screws with new ones.



# SUPPLEMENTAL RESTRAINT SYSTEM (SRS)

## Removal — Supplemental Air Bag Module and Spiral Cable

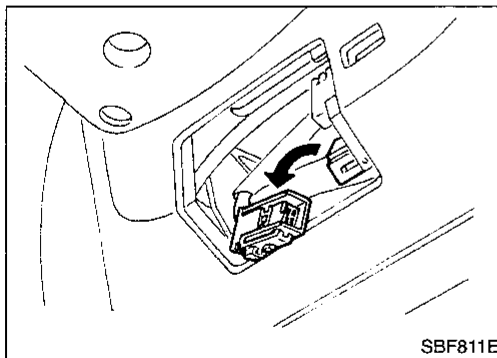
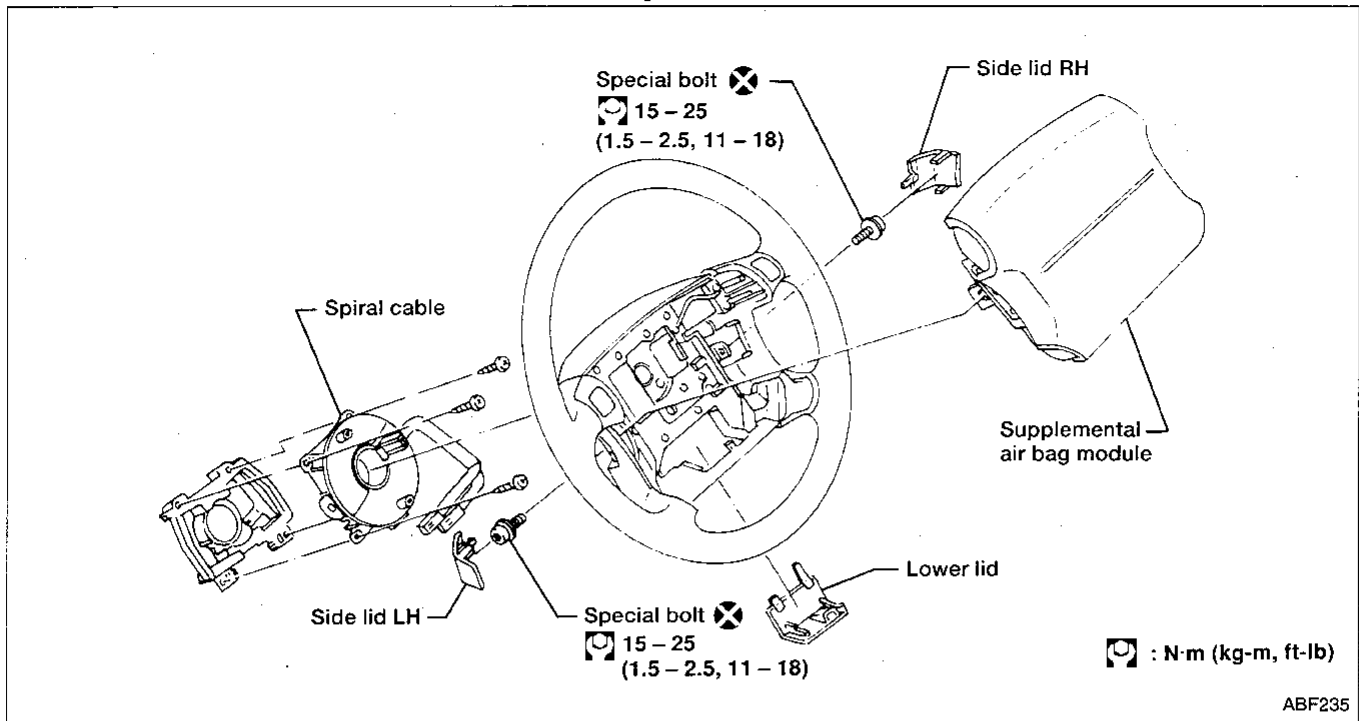

### CAUTION:

- Before servicing SRS, turn the ignition switch off, disconnect battery ground cable and wait for at least 10 minutes.
- Always service the supplemental air bag module from the side of the steering wheel.

1. Remove lower lid from steering wheel, and disconnect supplemental air bag module connector.

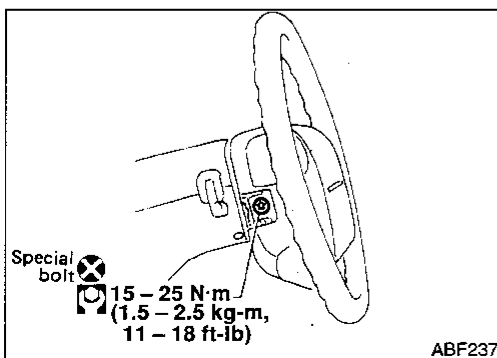

2. Remove left and right side lids. Using the T50H torx bit, remove left and right special bolts. Supplemental air bag module can then be removed.

## SUPPLEMENTAL RESTRAINT SYSTEM (SRS)

### Removal — Supplemental Air Bag Module and Spiral Cable (Cont'd)

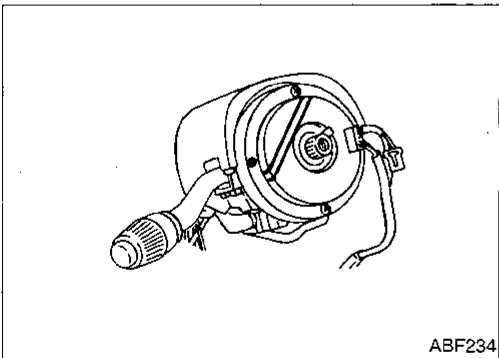
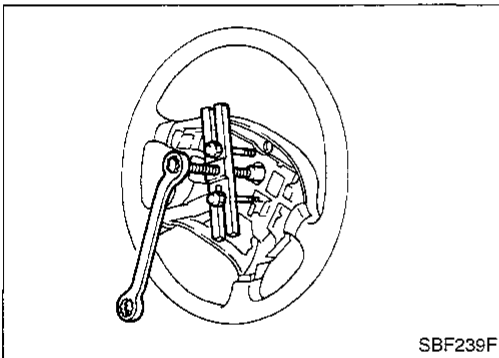
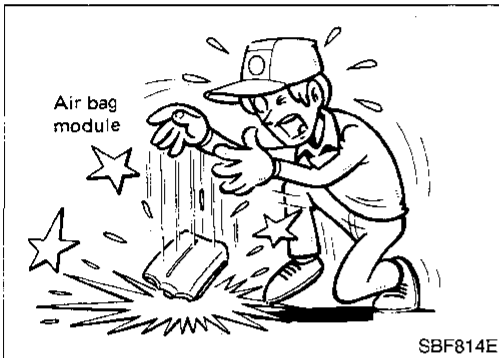
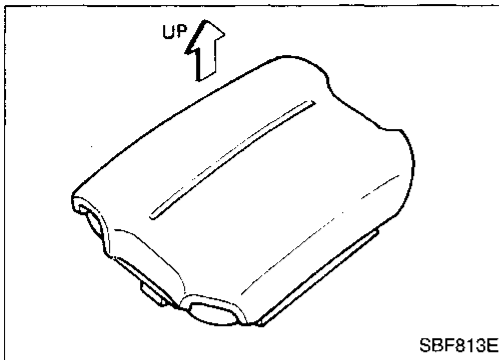

#### CAUTION:

- Always place supplemental air bag module with pad side facing upward.
- Do not attempt to disassemble supplemental air bag module.
- The special bolts are coated with bonding agent. Discard old ones after removal; replace with new ones.
- Do not insert an alien item (screwdriver, etc.) into supplemental air bag module connector.

- Do not use a circuit tester to check the supplemental air bag module harness connector.
- Do not drop or impact supplemental air bag module. If any portion is deformed or cracked, replace the supplemental air bag module.
- Do not expose the supplemental air bag module to temperatures exceeding 100°C (212°F).
- Do not allow oil, grease or water to come in contact with the supplemental air bag module.

3. Set steering wheel in the neutral position.
4. Remove steering wheel bolt.
5. Disconnect horn connector.
6. Using steering wheel puller, remove steering wheel. Be careful not to over-tighten puller bolt on steering wheel.

7. Remove four screws and lower console center cover.
8. Remove five screws and LH knee reinforcement plate.
9. Remove lower steering column cover.
10. Remove three screws and position spiral cable out of way.
11. Remove lock cylinder retaining pin.
12. Remove lock cylinder and key switch.
13. Remove spiral cable.

GI

MA

EM

LC

EF &  
EC

FE

AT

FA

RA

BR

ST

**BF**

HA

E

IDX

## Installation — Supplemental Air Bag Module and Spiral Cable

1. Install key switch and lock cylinder.

**NOTE:** If installing a new service part with yellow lock tab go to step 5.

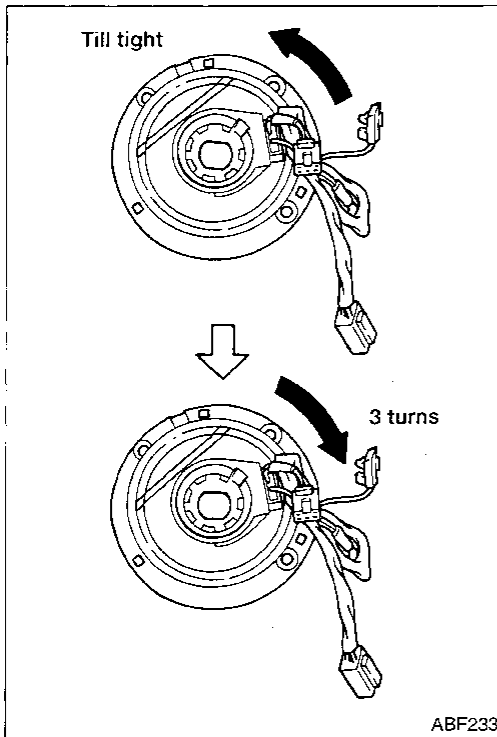

2. Rotate inner element of spiral cable counterclockwise until tight.
3. Place alignment marks on inner and outer spiral cable housings.
4. Rotate inner element of spiral cable clockwise three turns and align the alignment marks.
5. Position spiral cable on steering column and install three screws.
6. Install lower steering column cover.
7. Install LH knee reinforcement plate and five screws.
8. Install lower console center cover and four screws.

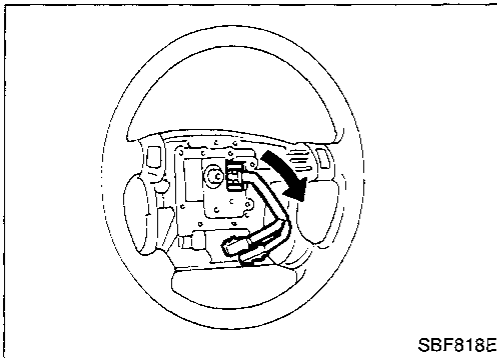

9. Install steering wheel and pull spiral cable through.
10. Connect horn connector.
11. Tighten steering wheel bolt.
12. After mounting steering wheel remove yellow lock tab on spiral cable (for new service part only).

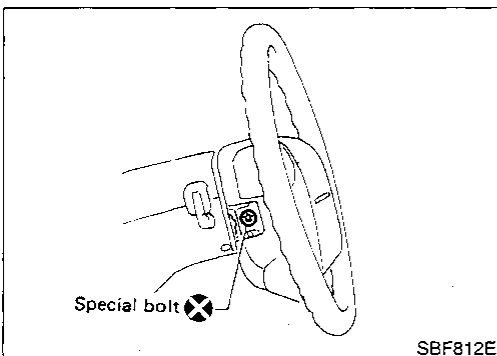

13. Position supplemental air bag module and tighten with new special bolts.
14. Connect supplemental air bag module connector.
15. Install all lids.
16. Conduct self-diagnosis to ensure entire SRS operates properly. (Use CONSULT or warning lamp check.)



# SUPPLEMENTAL RESTRAINT SYSTEM (SRS)

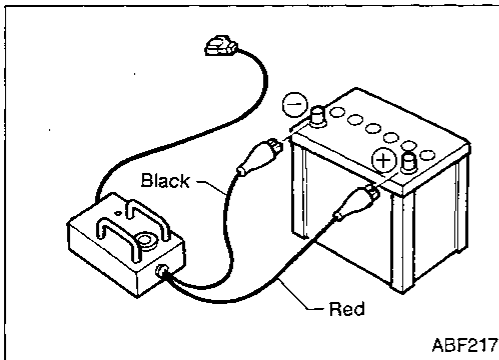

## Scrapping the Supplemental Air Bag

Before scrapping a supplemental air bag module or a vehicle equipped with an SRS supplemental air bag, be sure to deploy supplemental air bag.

### CONNECTING TO BATTERY

- Place the vehicle outdoors in such a way that it is surrounded on all sides by at least 6 m (20 ft) of open space.
- Use a voltmeter to make sure the vehicle battery is fully charged.

#### CAUTION:

**The battery must show voltage of 9.6V or more.**

Remove the battery from the vehicle and place it on dry wood blocks approximately 5 m (16 ft) away from the vehicle.

- Wait 10 to 12 minutes after the vehicle battery is disconnected before proceeding.
- Connect deployment tool to the battery.

#### CAUTION:

**Make sure the polarity is correct. The right side lamp in the tool, marked "deployment tool power", should glow with a green light. If the right side lamp glows red, reverse the connections to the battery.**

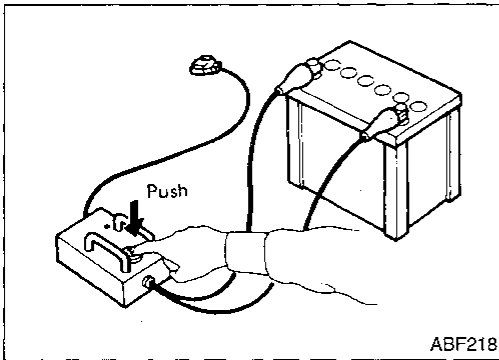

### DEPLOYMENT TOOL CHECK

Press the deployment tool switch to the "ON" position. The left side lamp in the tool, marked "air bag connector voltage" should illuminate. If it does not illuminate, replace the tool.

### SUPPLEMENTAL AIR BAG DEPLOYMENT TOOL LAMP ILLUMINATION CHART (Battery connected)

Switch operation	Left side lamp, green* "AIR BAG CONNECTOR VOLTAGE"	Right side lamp, green* "DEPLOYMENT TOOL POWER"
OFF	OFF	ON
ON	ON	ON

\*: If this lamp glows red, the tool is connected to the battery incorrectly. Reverse the connections and make sure the lamp glows green.

CI  
MA  
EM  
LC  
EF &  
EC  
FE  
AT  
FA  
RA  
BR  
ST  
BF  
HA  
EL  
IDX

## SUPPLEMENTAL RESTRAINT SYSTEM (SRS)

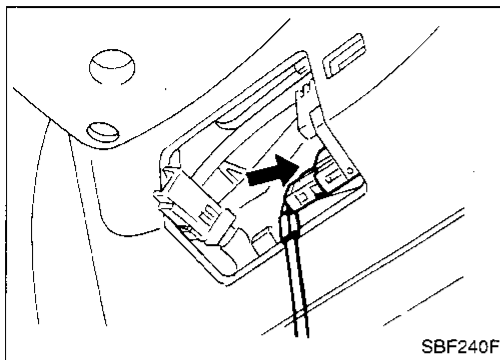

### Scrapping the Supplemental Air Bag (Cont'd)

#### CONNECTING TO SUPPLEMENTAL AIR BAG

- Disconnect the prepared battery cable.
- Also disconnect the vehicle battery ground cable and wait 10 minutes.
- Disconnect the supplemental air bag module connector.
- Connect the deployment tool connector.

#### CAUTION:

**Make sure the deployment tool is disconnected from the battery before you make this connection.**

- Reconnect the battery cable to the prepared battery.
- The lamp on the right side of the tool, marked "deployment tool power", should glow green, not red.

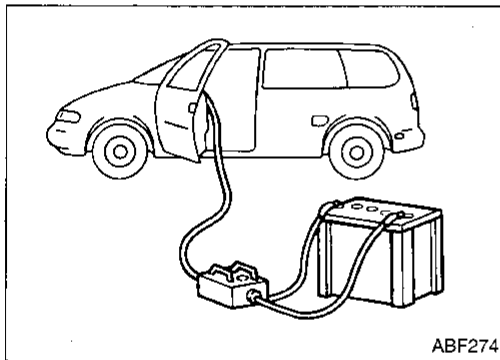

#### DEPLOYMENT

Press the button on the deployment tool. The left side lamp on the tool, marked "air bag connector voltage", will illuminate and the supplemental air bag will deploy.

#### DISPOSAL

- Remove steering wheel side lids. Use the special "torx" bit to remove the supplemental air bag module from the steering wheel. Place it into a sealed vinyl bag for disposal.

#### CAUTION:

- **When deploying supplemental air bag, ensure vehicle is empty.**
- **No poisonous gas is produced upon supplemental air bag deployment. However, be careful not to inhale gas since it irritates throat and can cause choking.**
- **Due to heat, leave supplemental air bag module unattended for more than 30 minutes after supplemental air bag deployment.**
- **Do not attempt to disassemble supplemental air bag module.**
- **Supplemental air bag module cannot be re-used.**
- **Never apply water to a deployed supplemental air bag module.**
- **Be sure to wear gloves when handling a deployed supplemental air bag module.**
- **Wash your hands clean after finishing work.**

Schematic

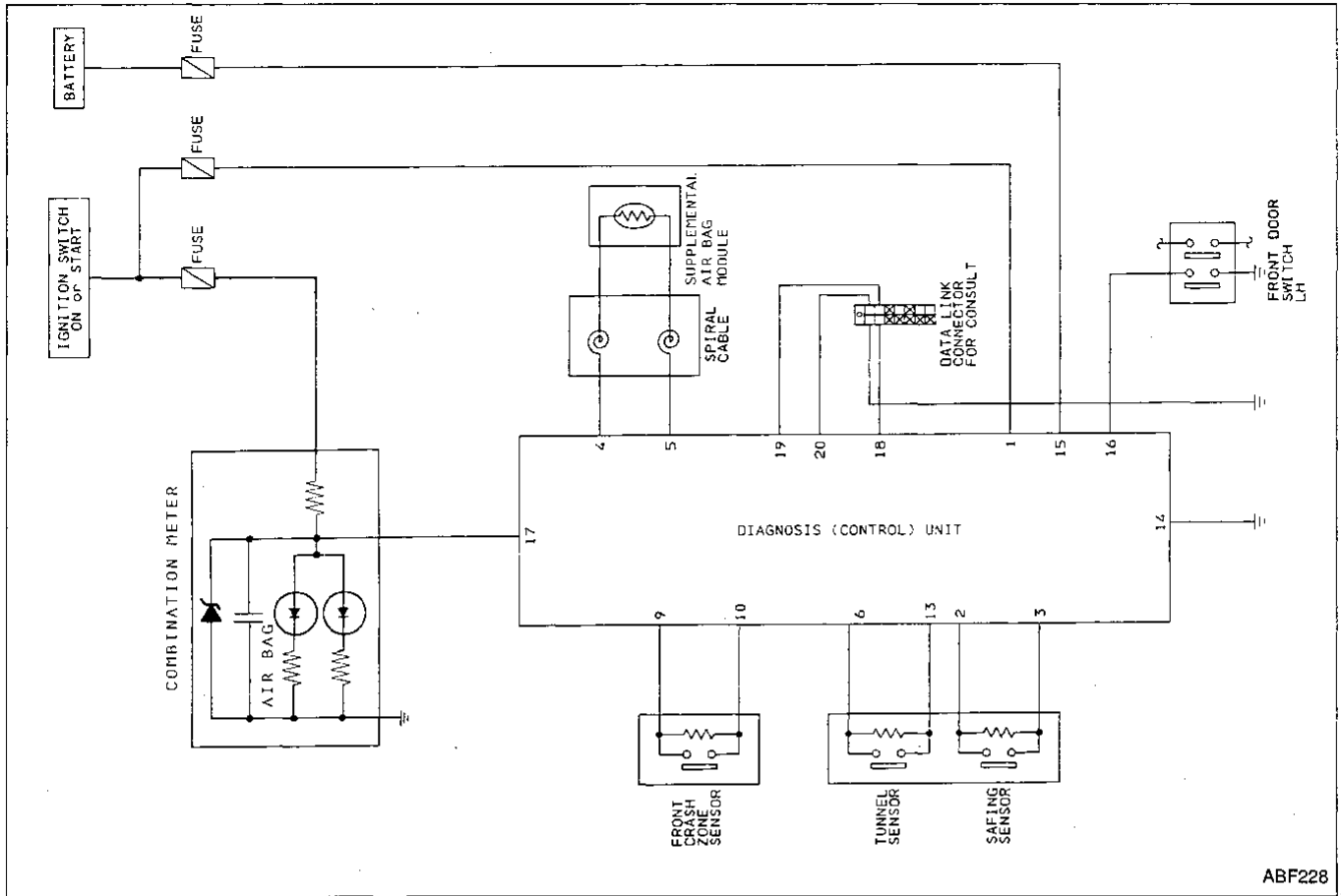

ABF228

Wiring Diagram -SRS-

CAUTION:

- Do not use a circuit tester to check SRS supplemental "Air Bag" harness connectors. The wiring harness and connectors have yellow outer insulation for easy identification.
- Do not attempt to repair, splice or modify the SRS supplemental "Air Bag" wiring harness. If the harness is damaged, replace it with a new one.
- Keep ground portion clean.

GI  
MA  
EM  
LC  
EF & EC  
FE  
AT  
FA  
RA  
BR  
ST  
BF  
HA  
EL  
IDX

# TROUBLE DIAGNOSES — Supplemental Restraint System (SRS)

## Wiring Diagram —SRS— (Cont'd)

BF-SRS-01

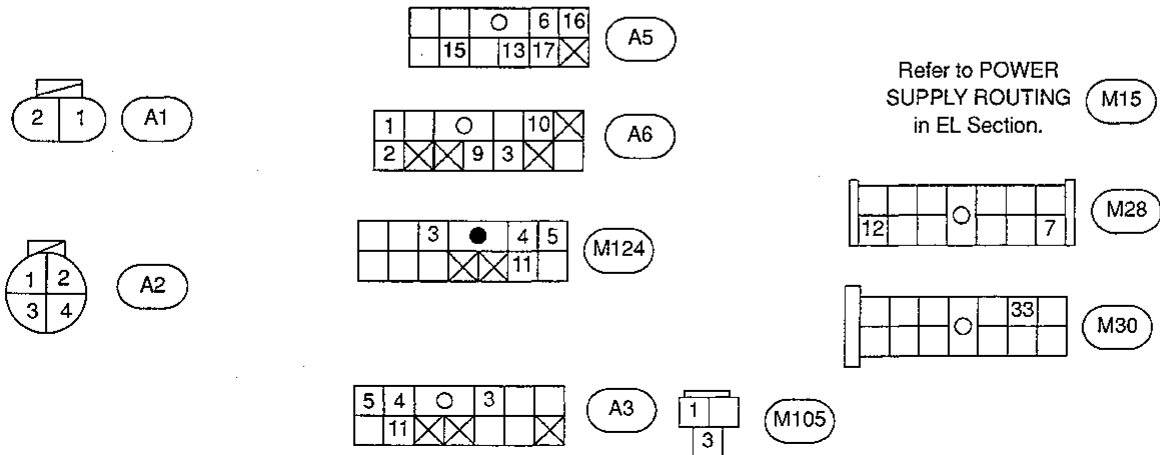
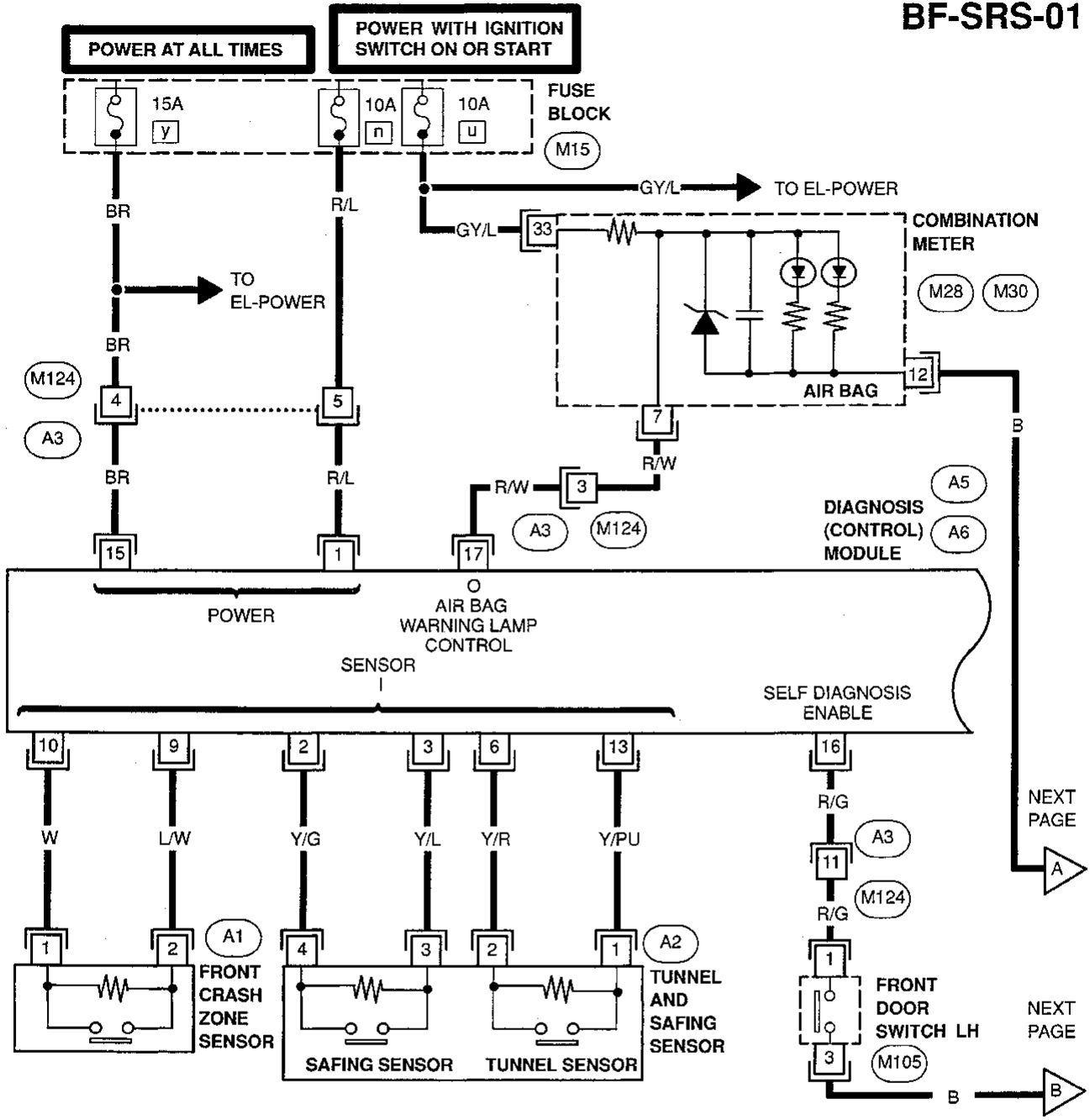

# TROUBLE DIAGNOSES — Supplemental Restraint System (SRS)

## Wiring Diagram —SRS— (Cont'd)

**BF-SRS-02**

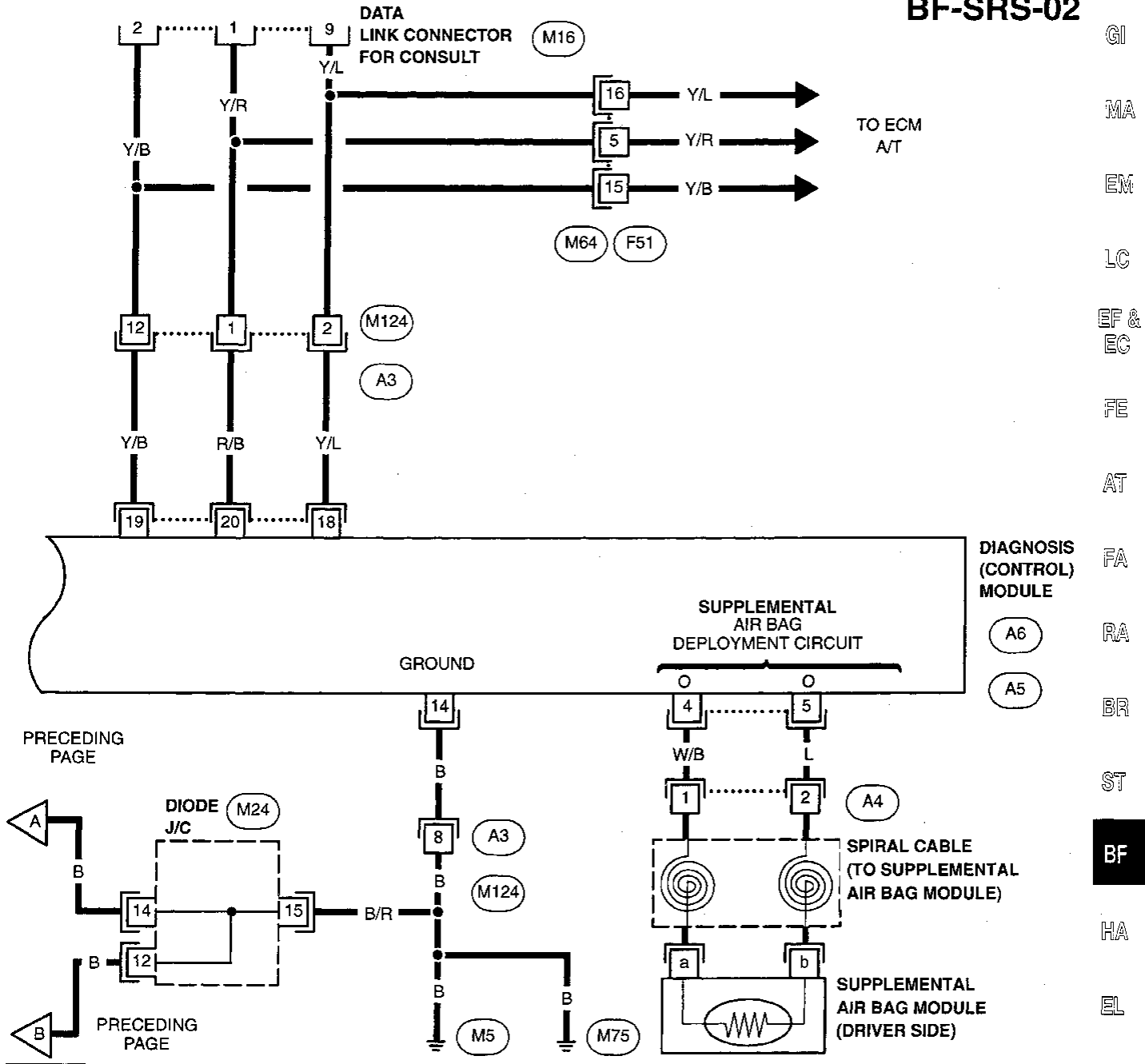

PRECEDING PAGE

A

B

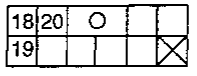
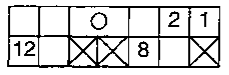
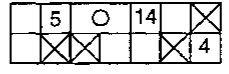
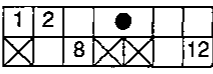
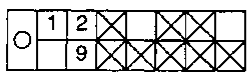

Refer to Foldout Page in EL Section for details.

(M24)

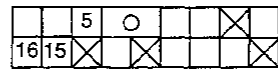
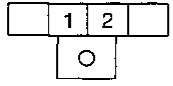
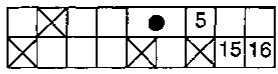

ABF226-B

GI  
MA  
EM  
LC  
EF & EC  
FE  
AT  
FA  
RA  
BR  
ST  
BF  
HA  
EL  
IDX

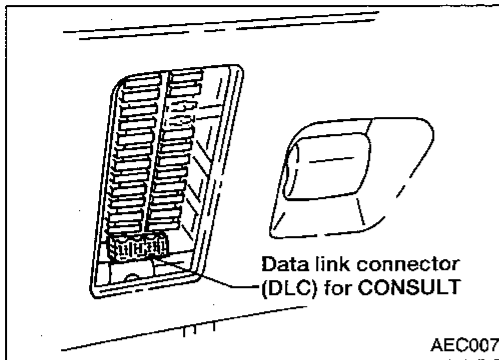

## IMPORTANT!

While CONSULT is displaying this self-diagnosis information, do not disconnect CONSULT from data link connector.

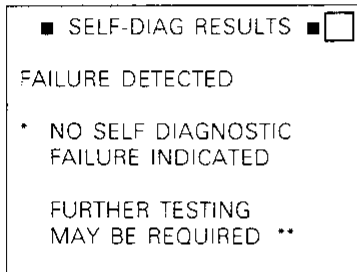

When finishing supplemental airbag diagnosis by CONSULT, make sure to change CONSULT display to SELECT SYSTEM mode by using Back Key.

ABF294

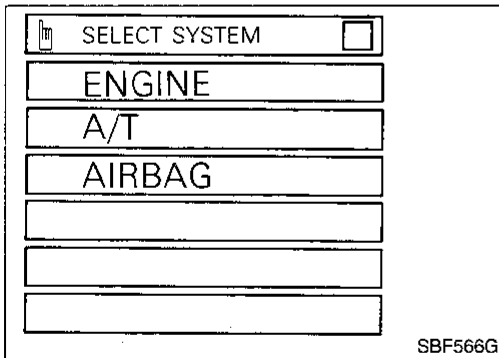

## Self-diagnosis USING CONSULT

The self-diagnosis results can be read by CONSULT, as follows:

1. Connect "CONSULT" to data link connector for CONSULT.
- ↓
2. Turn ignition switch to "ON". (When CONSULT is connected, the supplemental "AIR BAG" warning lamp will be turned to present diagnosis mode.)
- ↓
3. Touch "START" to operate "CONSULT".
- ↓
4. Touch "AIR BAG" to choose supplemental air bag system.
- ↓
5. Touch "SELF DIAG RESULTS" to read self-diagnosis results.
- ↓
6. Problem codes are displayed on "SELF DIAG RESULT 1" (first page — present mode). The problem code last indicated is displayed on "SELF DIAG RESULT 2" (second page — initial mode).
- ↓
7. When "PRINT" is pressed, information displayed on "SELF DIAG RESULTS 1 and 2" is printed out.
- ↓
8. After repairing malfunctioning parts, press "ERASE" to clear self-diagnosis results.
- **After repairing malfunctioning parts, attempt to clear self-diagnosis results from memory.**
- **If malfunctioning parts are not completely repaired, self-diagnosis results remain stored in memory.**
- ↓
9. Push Back Key of CONSULT until SELECT SYSTEM mode appears to make "SELF-DIAGNOSIS" user mode.
- ↓
10. Push the power off switch.
- ↓
11. Turn off ignition switch.

# TROUBLE DIAGNOSES — Supplemental Restraint System (SRS)

## Self-diagnosis (Cont'd)

### Self-diagnosis results

Diagnostic item [Present] and [Initial]	Explanation	Repair order * Recheck SRS at each replacement.	
NO SELF DIAGNOSTIC FAILURE INDICATED.	Normal. The SRS supplemental "Air Bag" is in good order.	—	GI MA
SAFING SENSOR [OPEN/LWR-GND-SHORT]	The circuit for the safing sensor is open or the wire from the safing sensor to the diagnosis (control) unit (terminal No. 3) is shorted.	1. Visually check the wiring harness connections. 2. Replace the safing sensor.	EM
SAFING SENSOR [SHORT/LWR-VB-SHORT]	Both the wires for the safing sensor are shorted or the wire from the safing sensor to the diagnosis (control) unit (terminal No. 3) is shorted to some power supply circuit.	(safing sensor and tunnel sensor) 3. Replace the diagnosis (control) unit. 4. Replace the main harness.	LC
AIRBAG MODULE [OPEN]	The circuit for the supplemental air bag module is open. (including the spiral cable)	1. Visually check the wiring harness connections. 2. Replace the spiral cable.	EF & EC
AIRBAG MODULE [VB-SHORT]	The circuit for the supplemental air bag module is shorted to some power supply circuit. (including the spiral cable)	3. Replace the supplemental air bag module. (Before disposing of it, it must be deployed.)	FE
AIRBAG MODULE [GND-SHORT]	The circuit for the supplemental air bag module is shorted to ground. (including the spiral cable)	4. Replace the diagnosis (control) unit. 5. Replace the main harness.	AT FA
AIRBAG MODULE [SHORT]	The circuits for the supplemental air bag module are shorted to each other.		
TUNNEL SENSOR [OPEN/UPR-VB-SHORT]	The circuit for the tunnel sensor is open or the wire from the diagnosis (control) unit (terminal No. 6) to the tunnel sensor is shorted to some power supply circuit.	1. Visually check the wiring harness connections. 2. Replace the tunnel sensor. (safing sensor and tunnel sensor)	RA BR
TUNNEL SENSOR [SHORT]	The circuits for the tunnel sensor are shorted to each other.	3. Replace the diagnosis (control) unit. 4. Replace the main harness.	ST
CRASH ZONE SEN-CTR [OPEN/UPR-VB-SHORT]	The circuit for the front crash zone sensor is open or the wire from the diagnosis (control) unit (terminal No. 9) to the front crash zone sensor is shorted to some power supply circuit.	1. Visually check the wiring harness connections. 2. Replace the front crash zone sensor. 3. Replace the diagnosis (control) unit. 4. Replace the main harness.	<b>BF</b>
CRASH ZONE SEN-CTR [SHORT]	The circuits for the front crash zone sensor are shorted to each other.		HA
CONTROL UNIT	The diagnosis (control) unit is out of order.	1. Visually check the wiring harness connections. 2. Replace the diagnosis (control) unit. 3. Replace the main harness.	EL IDX
INDEFINITE FAILURES	A problem which cannot be specified occurs because more than two parts are out of order.	1. See the SELF-DIAGNOSIS RESULT 2 trouble parts group [initial], then repair as necessary. 2. Visually check the wiring harness connections. 3. Replace the diagnosis (control) unit. 4. Replace all sensors, the spiral cable and supplemental air bag module. 5. Replace the main harness.	

# TROUBLE DIAGNOSES — Supplemental Restraint System (SRS)

## Self-diagnosis (Cont'd) USING THE WARNING LAMP

Self-diagnosis results (problem codes) can be also read by using the supplemental "AIR BAG" warning lamp. The supplemental "AIR BAG" warning lamp on the instrument panel operates as shown below:

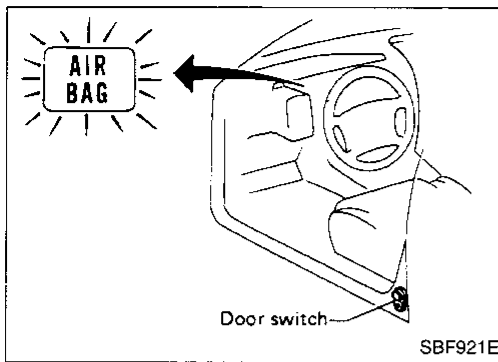

### How to alternate self-diagnosis and erase codes

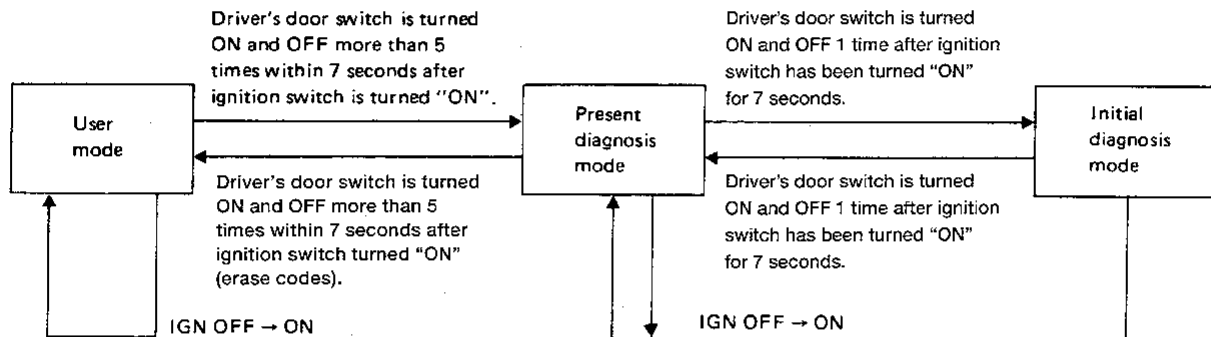

ABF211

Problem codes are displayed in present diagnosis mode (self-diagnosis result 1). The problem code last indicated is displayed in initial diagnosis mode (self-diagnosis result 2).

- After repairing malfunctioning part, attempt to clear self-diagnosis results from memory by returning to user mode.
- If a malfunctioning part is not completely repaired, self-diagnosis results will not be cleared.

#### Important:

"AIR BAG" warning lamp will continue to flash if:

1. System is not returned to user mode.
2. Malfunctioning parts are not completely repaired.

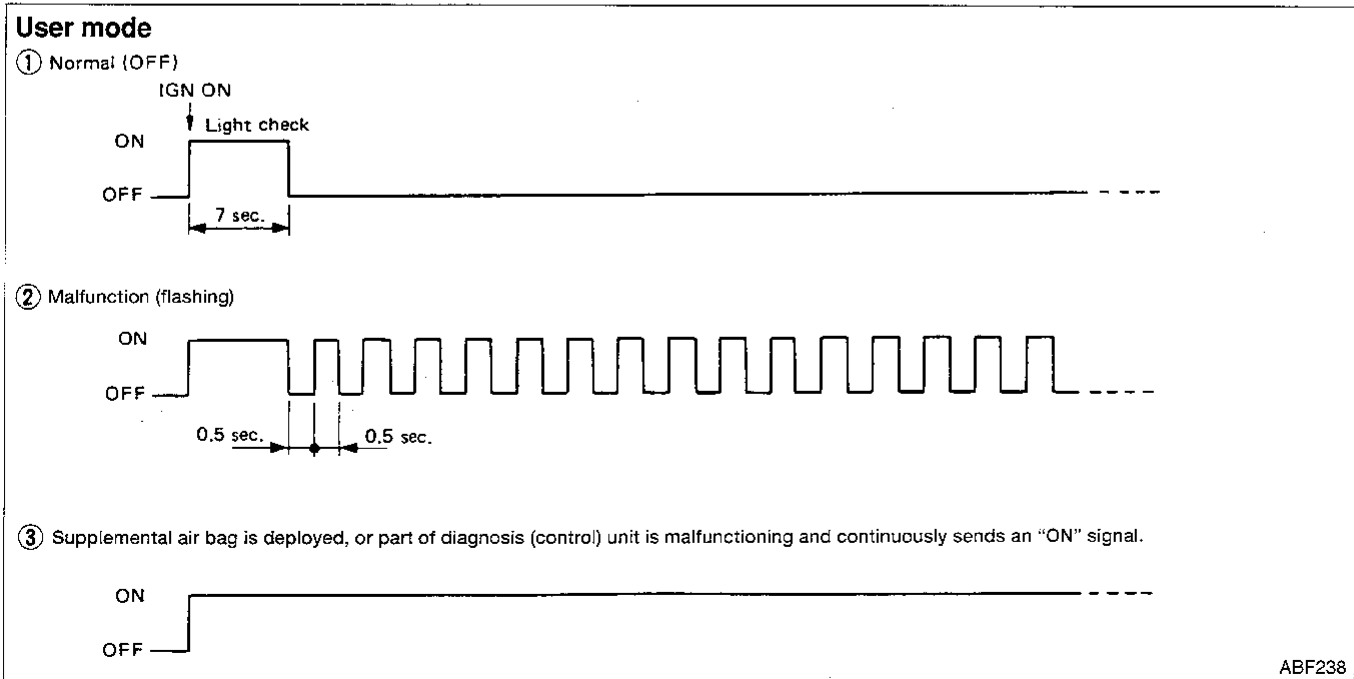

ABF238



# TROUBLE DIAGNOSES — Supplemental Restraint System (SRS)

## Self-diagnosis (Cont'd)

### Present diagnosis mode (self-diagnosis result 1)

(b) Start signal; Start signal identifies display modes.

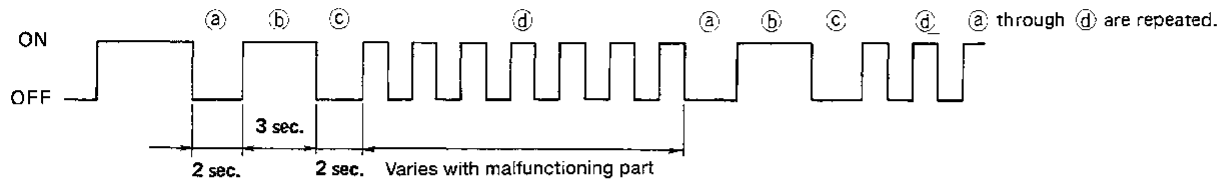

• No trouble (or intermittent trouble/repair completion)

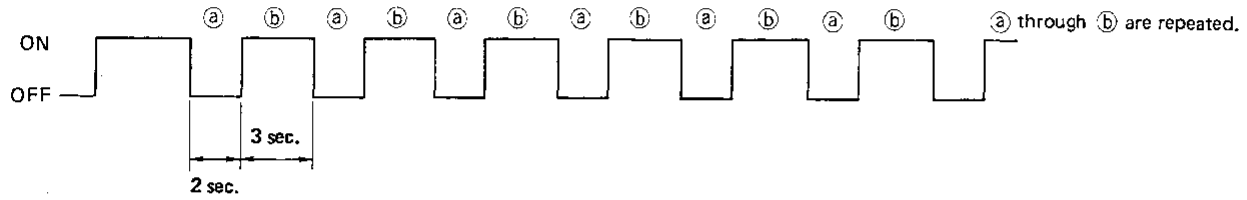

ABF292

### Initial diagnosis mode (self-diagnosis result 2)

(b) Start signal; Start signal identifies display modes.

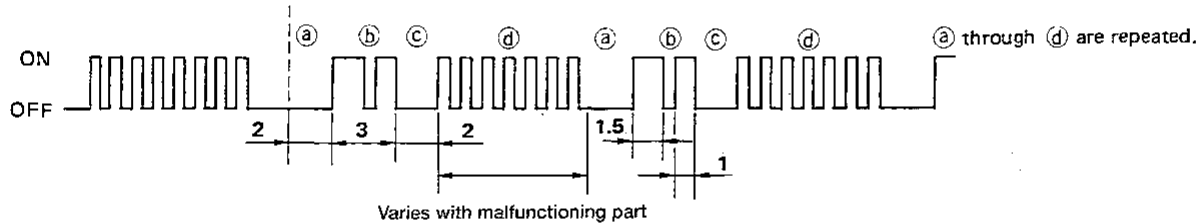

• No trouble

Unit: sec.

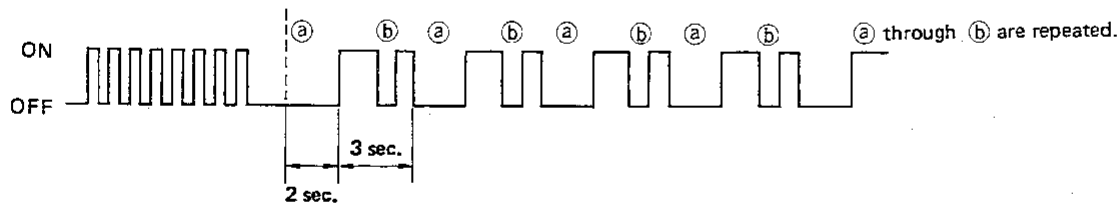

ABF293

Self-diagnosis results in present- and initial-diagnosis modes can be identified by number of flashes (d). Refer to Table on next page for malfunctioning parts.

# TROUBLE DIAGNOSES — Supplemental Restraint System (SRS)

## Self-diagnosis (Cont'd)

### Warning lamp flashing times and repair

Flash code (a) (# of flashes)	Explanation	Repair order * Recheck SRS at each replacement.
0	Normal. The SRS supplemental "Air Bag" is in good order.	—
1	The circuit for the safing sensor is out of order.	<ol style="list-style-type: none"> <li>1. Visually check the wiring harness connections.</li> <li>2. Replace the safing sensor. (safing sensor and tunnel sensor)</li> <li>3. Replace the diagnosis (control) unit.</li> <li>4. Replace the main harness.</li> </ol>
2	The circuit for the supplemental air bag module is out of order.	<ol style="list-style-type: none"> <li>1. Visually check the wiring harness connections.</li> <li>2. Replace the spiral cable.</li> <li>3. Replace the supplemental air bag module. (Before disposing of it, it must be deployed.)</li> <li>4. Replace the diagnosis (control) unit.</li> <li>5. Replace the main harness.</li> </ol>
3	The circuit for the tunnel sensor is out of order.	<ol style="list-style-type: none"> <li>1. Visually check the wiring harness connections.</li> <li>2. Replace the tunnel sensor. (safing sensor and tunnel sensor)</li> <li>3. Replace the diagnosis (control) unit.</li> <li>4. Replace the main harness.</li> </ol>
6	The circuit for the front crash zone sensor is out of order.	<ol style="list-style-type: none"> <li>1. Visually check the wiring harness connections.</li> <li>2. Replace the front crash zone sensor.</li> <li>3. Replace the diagnosis (control) unit.</li> <li>4. Replace the main harness.</li> </ol>
7	The diagnosis (control) unit is out of order.	<ol style="list-style-type: none"> <li>1. Visually check the wiring harness connections.</li> <li>2. Replace the diagnosis (control) unit.</li> <li>3. Replace the main harness.</li> </ol>
8	More than two parts groups are out of order.	<ol style="list-style-type: none"> <li>1. See the SELF-DIAGNOSIS RESULT 2 diagnostic item [Initial], then repair it.</li> <li>2. Visually check the wiring harness connections.</li> <li>3. Replace the diagnosis (control) unit.</li> <li>4. Replace all sensors, spiral cable and supplemental air bag module.</li> <li>5. Replace the main harness.</li> </ol>

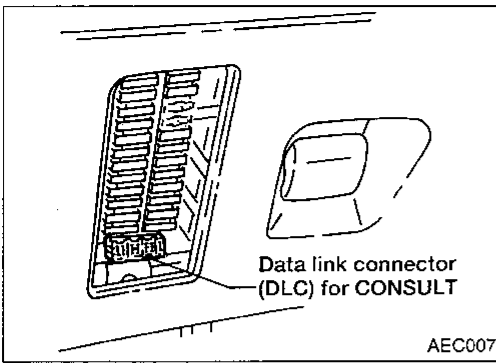

## Diagnostic Procedure 1

**SYMPTOM: Warning lamp flashes.**

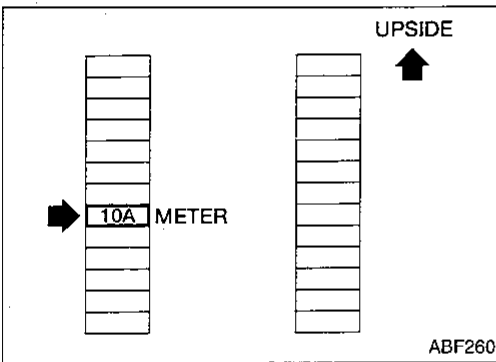
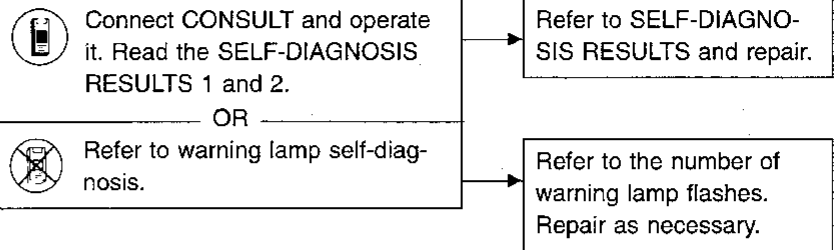

## Diagnostic Procedure 2

**SYMPTOM: Warning lamp does not come on.**

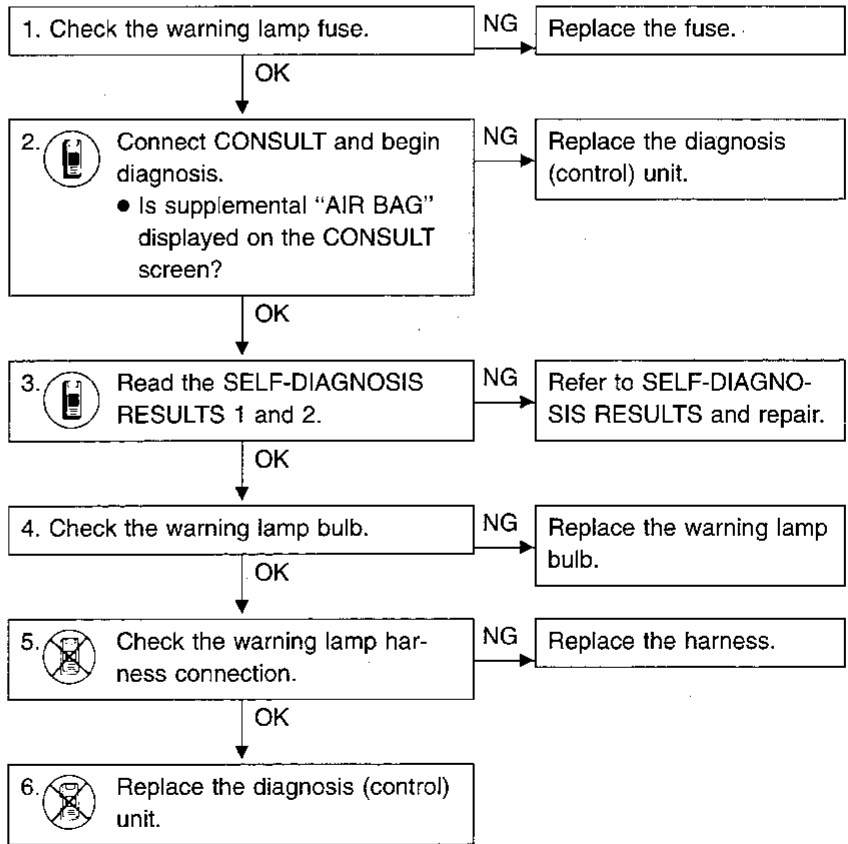
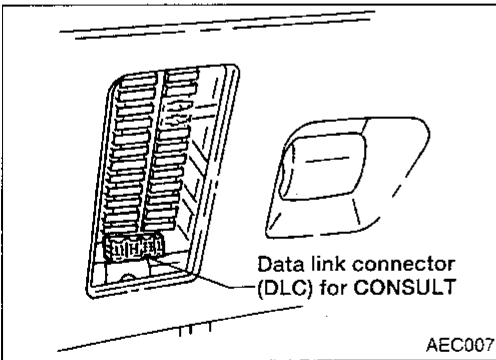

GI  
MA  
EM  
LC  
EF & EC  
FE  
AT  
FA  
RA  
BR  
ST  
BF  
HA  
EL  
DX

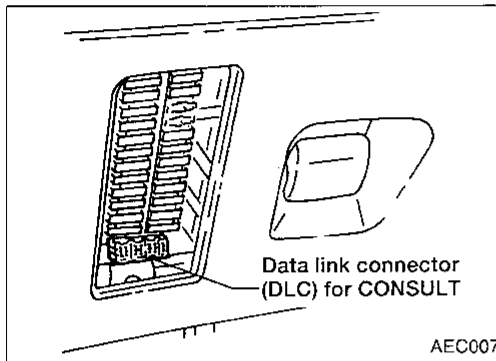
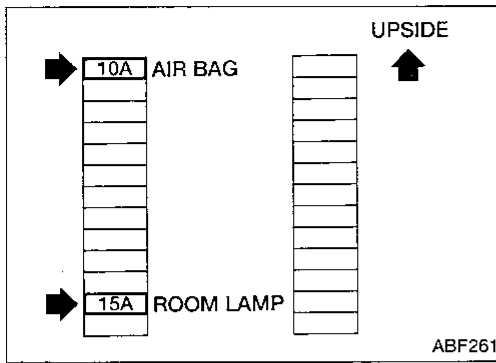

## Diagnostic Procedure 3

**SYMPTOM: Warning lamp does not go off.**

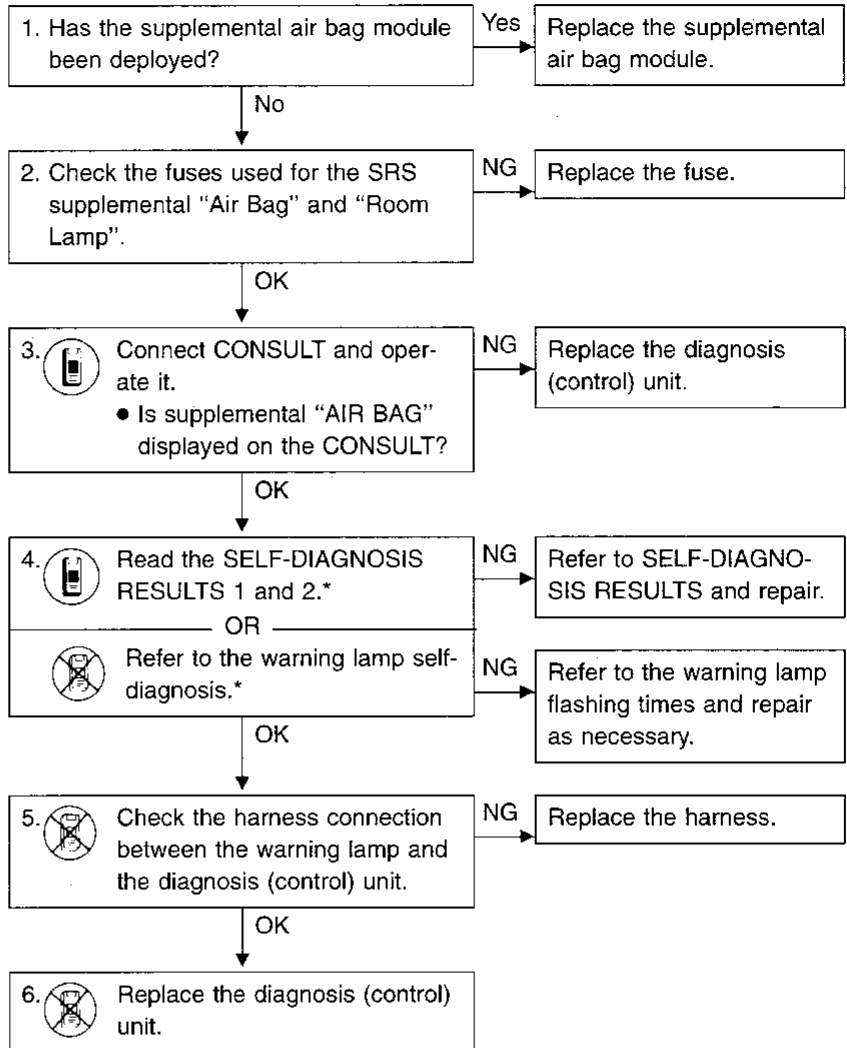

\* Recheck SRS after each replacement.

## Collision Diagnosis

To repair the SRS Supplemental "AIR BAG", perform the following steps.

### When supplemental air bag deployed in a collision:

- ① Replace the diagnosis (control) unit.
- ② Remove the supplemental air bag module.
- ③ Check the SRS components using the table shown below:
  - If the SRS components are showing any visible damage such as dents, cracks, or deformation, replace them with new ones.
- ④ Conduct self-diagnosis using CONSULT or Supplemental "AIR BAG" warning lamp to ensure entire SRS operates properly except open circuits of air bag module.
- ⑤ Install new supplemental air bag module.
- ⑥ Conduct self-diagnosis again, and erase the memory using CONSULT or the "AIR BAG" warning lamp.

### Important:

- "AIR BAG" warning lamp will continue to flash if:
  1. Erasing is not performed.
  2. System is not returned to user mode.
  3. Malfunctioning parts are not completely repaired.
- ⑦ Turn ignition switch "ON". "AIR BAG" warning lamp should come on for about 7 seconds, then go off.

### When supplemental air bag did not deploy in a collision:

- ① Check the SRS components using the table shown below:
  - If the SRS components are showing any visible damage such as dents, cracks, or deformation, replace them with new ones.
- ② Conduct self-diagnosis using CONSULT or Supplemental "AIR BAG" warning lamp to ensure entire SRS operates properly.

### SRS inspection

Part	Supplemental air bag deployed	Supplemental air bag did NOT deploy
Supplemental air bag module	REPLACE Install with new bolts.	<ol style="list-style-type: none"> <li>1. Remove supplemental air bag module. Check harness cover and connectors for damage, terminals for deformities, and harness for binding.</li> <li>2. Install supplemental air bag module into the steering wheel to check fit and alignment with the wheel.</li> <li>3. No damage found, reinstall with new bolts.</li> <li>4. If damaged—REPLACE. Supplemental air bag must be deployed before discarding.</li> </ol>
Diagnosis (control) unit	REPLACE Install with new bolts.	<ol style="list-style-type: none"> <li>1. Check case and bracket for dents, cracks or deformities.</li> <li>2. Check connectors for damage, and terminals for deformities.</li> <li>3. If no damage is found, reinstall with new bolts.</li> <li>4. If damaged—REPLACE.</li> </ol>
Sensors		<ol style="list-style-type: none"> <li>1. Check body and sensor brackets for deformities or rust.</li> <li>2. Check sensor case for dents, cracks, scratches, deformities or rust.</li> <li>3. Check sensor harness, connector, and terminals for binding, damage, or deformities.</li> <li>4. If no damage is found, reinstall with new bolts.</li> <li>5. If damaged—REPLACE.</li> </ol>
Steering wheel		<ol style="list-style-type: none"> <li>1. Check harness (built into steering wheel) and connectors for damage, and terminals for deformities.</li> <li>2. Install supplemental air bag module to check fit or alignment with steering wheel.</li> <li>3. Check steering wheel for excessive free play.</li> <li>4. If no damage is found, reinstall with new bolts.</li> <li>5. If damaged—REPLACE.</li> </ol>
Spiral cable		<ol style="list-style-type: none"> <li>1. Visually check lock (engagement) pins and combination switch for damage.</li> <li>2. Check connectors, flat cable and protective tape for damage.</li> <li>3. Check steering wheel for noise, binding or heavy operation.</li> <li>4. If no damage is found, reinstall with new bolts.</li> <li>5. If damaged—REPLACE.</li> </ol>
Harness and Connectors		<ol style="list-style-type: none"> <li>1. Check connectors for poor connection, damage, and terminals for deformities.</li> <li>2. Check harness for binding, chafing, cuts, or deformities.</li> <li>3. If no damage is found, reinstall.</li> <li>4. Damaged—REPLACE damaged section of harness. Do not attempt to repair, splice or modify any SRS harness.</li> </ol>