

# SECTION **DI**

## DRIVER INFORMATION SYSTEM

A  
B  
C  
D  
E

### CONTENTS

<p><b>PRECAUTION</b> ..... 3</p> <p style="padding-left: 20px;">Precautions for Supplemental Restraint System (SRS) "AIR BAG" and "SEAT BELT PRE-TENSIONER" ..... 3</p> <p><b>PREPARATION</b> ..... 4</p> <p style="padding-left: 20px;">Commercial Service Tool ..... 4</p> <p><b>COMBINATION METERS</b> ..... 5</p> <p style="padding-left: 20px;">System Description ..... 5</p> <p style="padding-left: 40px;">UNIFIED METER CONTROL UNIT ..... 5</p> <p style="padding-left: 40px;">POWER SUPPLY AND GROUND CIRCUIT ..... 5</p> <p style="padding-left: 40px;">WATER TEMPERATURE GAUGE ..... 5</p> <p style="padding-left: 40px;">TACHOMETER ..... 5</p> <p style="padding-left: 40px;">FUEL GAUGE ..... 5</p> <p style="padding-left: 40px;">SPEEDOMETER ..... 5</p> <p style="padding-left: 40px;">CAN COMMUNICATION SYSTEM DESCRIPTION ..... 5</p> <p style="padding-left: 20px;">Component Parts and Harness Connector Location... 6</p> <p style="padding-left: 20px;">Combination Meter ..... 7</p> <p style="padding-left: 40px;">CHECK ..... 7</p> <p style="padding-left: 20px;">Circuit Diagram ..... 8</p> <p style="padding-left: 20px;">Wiring Diagram — METER — ..... 9</p> <p style="padding-left: 20px;">Terminals and Reference Value for Combination Meter ..... 11</p> <p style="padding-left: 20px;">Meter/Gauge Operation and Odo/Trip Meter ..... 12</p> <p style="padding-left: 40px;">SELF-DIAGNOSIS FUNCTION ..... 12</p> <p style="padding-left: 40px;">HOW TO INITIATE COMBINATION METER SELF-DIAGNOSIS MODE ..... 12</p> <p style="padding-left: 40px;">COMBINATION METER SELF-DIAGNOSIS MODE FUNCTIONS ..... 12</p> <p style="padding-left: 20px;">How to Proceed With Trouble Diagnosis ..... 14</p> <p style="padding-left: 20px;">Diagnosis Flow ..... 14</p> <p style="padding-left: 20px;">Power Supply and Ground Circuit Inspection ..... 15</p> <p style="padding-left: 20px;">Symptom Chart ..... 16</p> <p style="padding-left: 20px;">Vehicle Speed Signal Inspection ..... 16</p> <p style="padding-left: 20px;">Water Temperature Signal Inspection ..... 16</p> <p style="padding-left: 20px;">Engine Speed Signal Inspection ..... 16</p> <p style="padding-left: 20px;">Fuel Level Sensor Unit Inspection ..... 17</p> <p style="padding-left: 40px;">FUEL LEVEL SENSOR UNIT ..... 17</p> <p style="padding-left: 40px;">LOW-FUEL WARNING LAMP ..... 17</p> <p style="padding-left: 20px;">Fuel Gauge Fluctuates, Indicates Wrong Value, or</p>	<p style="padding-left: 20px;">Varies ..... 19</p> <p style="padding-left: 20px;">Fuel Gauge Does Not Move to Full-position ..... 19</p> <p style="padding-left: 20px;">Electrical Components Inspection ..... 20</p> <p style="padding-left: 40px;">FUEL LEVEL SENSOR UNIT CHECK ..... 20</p> <p style="padding-left: 20px;">Combination Meter ..... 20</p> <p style="padding-left: 40px;">REMOVAL AND INSTALLATION ..... 20</p> <p><b>WARNING LAMPS</b> ..... 21</p> <p style="padding-left: 20px;">Schematic ..... 21</p> <p style="padding-left: 20px;">Wiring Diagram — WARN — ..... 22</p> <p style="padding-left: 20px;">Oil Pressure Warning Lamp Stays Off (Ignition Switch ON) ..... 28</p> <p style="padding-left: 20px;">Oil Pressure Warning Lamp Does Not Turn Off (Oil Pressure Is Normal) ..... 29</p> <p style="padding-left: 20px;">Component Inspection ..... 29</p> <p style="padding-left: 40px;">OIL PRESSURE SWITCH ..... 29</p> <p><b>A/T INDICATOR</b> ..... 30</p> <p style="padding-left: 20px;">Wiring Diagram — AT/IND — ..... 30</p> <p style="padding-left: 20px;">Trouble Diagnosis ..... 32</p> <p style="padding-left: 20px;">A/T Indicator Does Not Illuminate ..... 32</p> <p><b>WARNING CHIME</b> ..... 33</p> <p style="padding-left: 20px;">Component Parts and Harness Connector Location.. 33</p> <p style="padding-left: 20px;">System Description ..... 34</p> <p style="padding-left: 40px;">FUNCTION ..... 34</p> <p style="padding-left: 40px;">IGNITION KEY WARNING CHIME ..... 34</p> <p style="padding-left: 40px;">LIGHT WARNING CHIME ..... 34</p> <p style="padding-left: 40px;">SEAT BELT WARNING CHIME ..... 34</p> <p style="padding-left: 40px;">LOW FUEL WARNING CHIME ..... 35</p> <p style="padding-left: 20px;">CAN Communication System Description ..... 35</p> <p style="padding-left: 20px;">Wiring Diagram — CHIME — ..... 36</p> <p style="padding-left: 20px;">Terminals and Reference Value for BCM ..... 38</p> <p style="padding-left: 20px;">Terminals and Reference Value for Combination Meter ..... 39</p> <p style="padding-left: 20px;">How to Proceed With Trouble Diagnosis ..... 39</p> <p style="padding-left: 20px;">Preliminary Check ..... 40</p> <p style="padding-left: 40px;">INSPECTION FOR POWER SUPPLY AND GROUND CIRCUIT ..... 40</p> <p style="padding-left: 20px;">CONSULT-II Function (BCM) ..... 41</p> <p style="padding-left: 40px;">CONSULT-II BASIC OPERATION PROCEDURE ..... 41</p> <p style="padding-left: 20px;">DATA MONITOR ..... 42</p>
---	---

F  
G  
H  
I  
J  
DI  
L  
M

ACTIVE TEST .....	42	SONAR BUZZER .....	58
SELF-DIAGNOSTIC RESULTS .....	42	REAR SONAR SYSTEM OFF SWITCH .....	58
All Warning Chimes Do Not Operate .....	43	REAR SONAR SYSTEM OFF INDICATOR .....	58
Key Warning Chime and Light Warning Chime Do Not Operate (Seat Belt Warning Chime Does Operate) .....	43	Rear Sonar Sensors .....	58
Key Warning Chime Does Not Operate .....	44	REMOVAL AND INSTALLATION .....	58
Light Warning Chime Does Not Operate .....	46	Sonar Control Unit .....	58
Seat Belt Warning Chime Does Not Operate .....	46	REMOVAL AND INSTALLATION .....	58
<b>REAR SONAR SYSTEM .....</b>	<b>49</b>	INSTALLATION .....	58
Component Parts and Harness Connector Location..	49	<b>REAR VIEW MONITOR .....</b>	<b>59</b>
System Description .....	49	Component Parts and Harness Connector Location..	59
FUNCTION .....	49	System Description .....	60
REAR SONAR SYSTEM OFF SWITCH .....	49	POWER SUPPLY AND GROUND .....	60
SONAR BUZZER .....	50	AV COMMUNICATION LINE .....	60
REAR SONAR SENSOR .....	50	REAR VIEW CAMERA OPERATION .....	60
Wiring Diagram — SONAR — .....	51	Schematic .....	61
Terminals And Reference Value For Sonar Control Unit .....	53	Wiring Diagram — R/VIEW — .....	62
How to Proceed With Trouble Diagnosis .....	53	Terminals and Reference Value for Rear View Camera Control Unit .....	65
Pre-diagnosis Inspection .....	54	CONSULT-II Function (REARVIEW CAMERA) .....	66
SENSOR STATUS CHECK .....	54	CONSULT-II BASIC OPERATION .....	66
Self-diagnosis Function .....	54	WORK SUPPORT .....	67
ENTERING DIAGNOSTICS MODE .....	54	DATA MONITOR .....	67
REQUESTING NUMBER OF FAULT CODES MODE .....	54	Side Distance Guideline Correction .....	68
MODE .....	54	SIDE DISTANCE GUIDELINE CORRECTION PROCEDURE .....	68
REQUESTING FAULT CODES MODE .....	55	Power Supply and Ground Circuit Inspection .....	70
IDLING OR CLEARING FAULT CODES MODE..	55	Rear View Is Not Displayed With The A/T Selector Lever In R Position .....	71
Preliminary Check .....	56	Rear View Camera Control Unit .....	75
INSPECTION FOR POWER SUPPLY AND GROUND CIRCUIT .....	56	REMOVAL AND INSTALLATION .....	75
Symptom Chart .....	57	Rear View Camera .....	75
Component Inspection .....	58	REMOVAL AND INSTALLATION .....	75

# PRECAUTION

## PRECAUTION

PF0:00011

### Precautions for Supplemental Restraint System (SRS) “AIR BAG” and “SEAT BELT PRE-TENSIONER”

EKS00FEW

The Supplemental Restraint System such as “AIR BAG” and “SEAT BELT PRE-TENSIONER”, used along with a front seat belt, helps to reduce the risk or severity of injury to the driver and front passenger for certain types of collision. This system includes seat belt switch inputs and dual stage front air bag modules. The SRS system uses the seat belt switches to determine the front air bag deployment, and may only deploy one front air bag, depending on the severity of a collision and whether the front occupants are belted or unbelted. Information necessary to service the system safely is included in the SRS and SB section of this Service Manual.

#### **WARNING:**

- To avoid rendering the SRS inoperative, which could increase the risk of personal injury or death in the event of a collision which would result in air bag inflation, all maintenance must be performed by an authorized NISSAN/INFINITI dealer.
- Improper maintenance, including incorrect removal and installation of the SRS, can lead to personal injury caused by unintentional activation of the system. For removal of Spiral Cable and Air Bag Module, see the SRS section.
- Do not use electrical test equipment on any circuit related to the SRS unless instructed to in this Service Manual. SRS wiring harnesses can be identified by yellow and/or orange harnesses or harness connectors.

A

B

C

D

E

F

G

H

I

J

DI

L

M

# PREPARATION

## PREPARATION

PF0:00002

### Commercial Service Tool

EKS00FEY

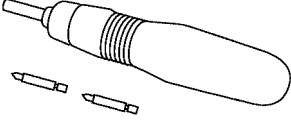
Tool name	Description
<p data-bbox="162 298 272 323">Power tool</p>  <p data-bbox="852 499 922 514">PBIC0191E</p>	<p data-bbox="1015 298 1266 323">Loosening bolts and nuts</p>

# COMBINATION METERS

## COMBINATION METERS

PF2:24814

### System Description

EKS00FEZ

#### UNIFIED METER CONTROL UNIT

- Speedometer, odometer, tachometer, fuel gauge and water temperature gauge are controlled by the unified meter control unit, which is built into the combination meter.
- Warning indicators are controlled by signals drawn from the CAN communication system, BCM (body control module), and components connected directly to the combination meter.
- Digital meter is adopted for odometer.\*  
\*The record of the odometer is kept even if the battery cable is disconnected.
- Odometer and A/T indicator segments can be checked in diagnosis mode.
- Meters/gauges can be checked in diagnosis mode.

#### Illumination control

The unified meter control unit outputs the odometer, A/T indicator, fuel and temperature gauge lighting when the ignition switch is turned on. When the lighting switch is turned on, the illumination control switch can be used to adjust the brightness of the combination meter illumination and the odometer and meter illumination. When the ignition switch is in the START position, the combination meter dial lighting and illumination control switch lighting are turned off. For additional combination meter illumination control information, refer to [LT-162, "System Description"](#).

#### POWER SUPPLY AND GROUND CIRCUIT

Power is supplied at all times

- through 15A fuse [No.19, located in the fuse block (J/B)]
- to combination meter terminal 31.

With the ignition switch in the ON or START position, power is supplied

- through 10A fuse [No.14, located in the fuse block (J/B)]
- to combination meter terminal 30.

Ground is supplied

- to combination meter terminal 32
- through body grounds M57, M61 and M79.

#### WATER TEMPERATURE GAUGE

The water temperature gauge indicates the engine coolant temperature. ECM provides a water temperature signal to combination meter via CAN communication lines.

#### TACHOMETER

The tachometer indicates engine speed in revolutions per minute (rpm). ECM provides an engine speed signal to combination meter via CAN communication lines.

#### FUEL GAUGE

The fuel gauge indicates the approximate fuel level in the fuel tank. The fuel gauge is regulated by the unified meter control unit and a variable resistor signal supplied

- to combination meter terminal 3
- through fuel level sensor unit and fuel pump terminal 5
- through fuel level sensor unit and fuel pump terminal 2
- from combination meter terminal 2.

#### SPEEDOMETER

ABS actuator and electric unit (control unit) provides a vehicle speed signal to the combination meter via CAN communication lines.

#### CAN COMMUNICATION SYSTEM DESCRIPTION

Refer to [LAN-24, "CAN COMMUNICATION"](#).

# COMBINATION METERS

## Component Parts and Harness Connector Location

EKS00FF0

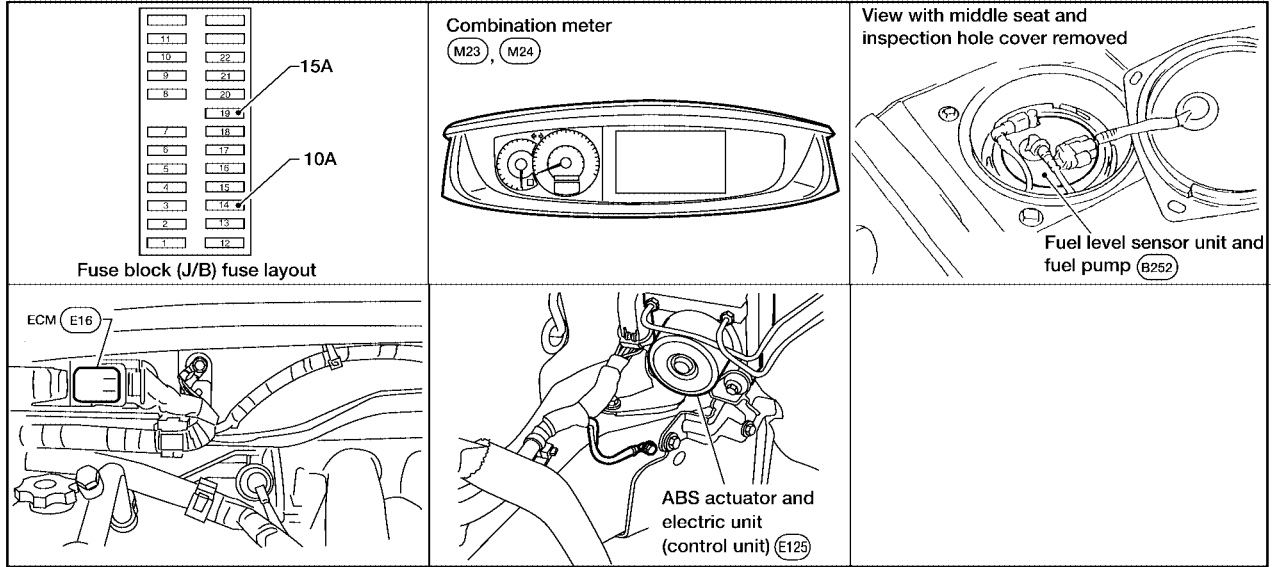

WKIA1125E

# COMBINATION METERS

## Combination Meter CHECK

EKS00FF1

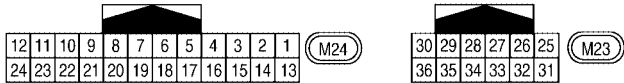
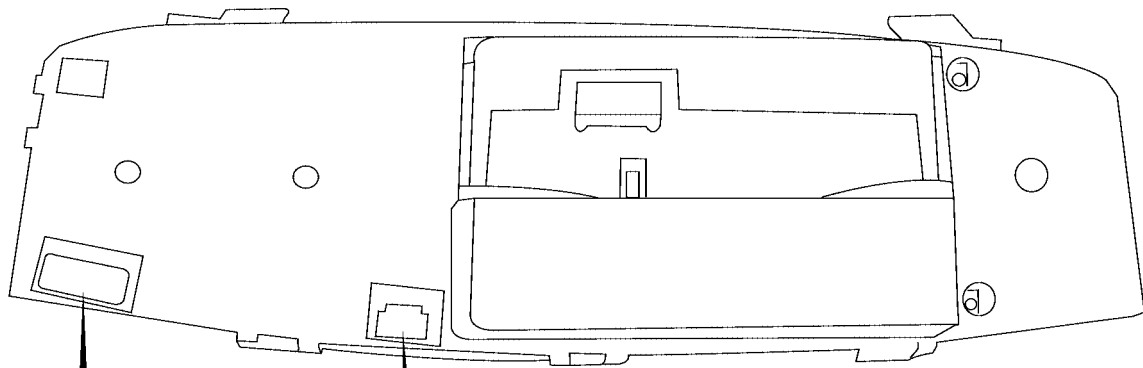
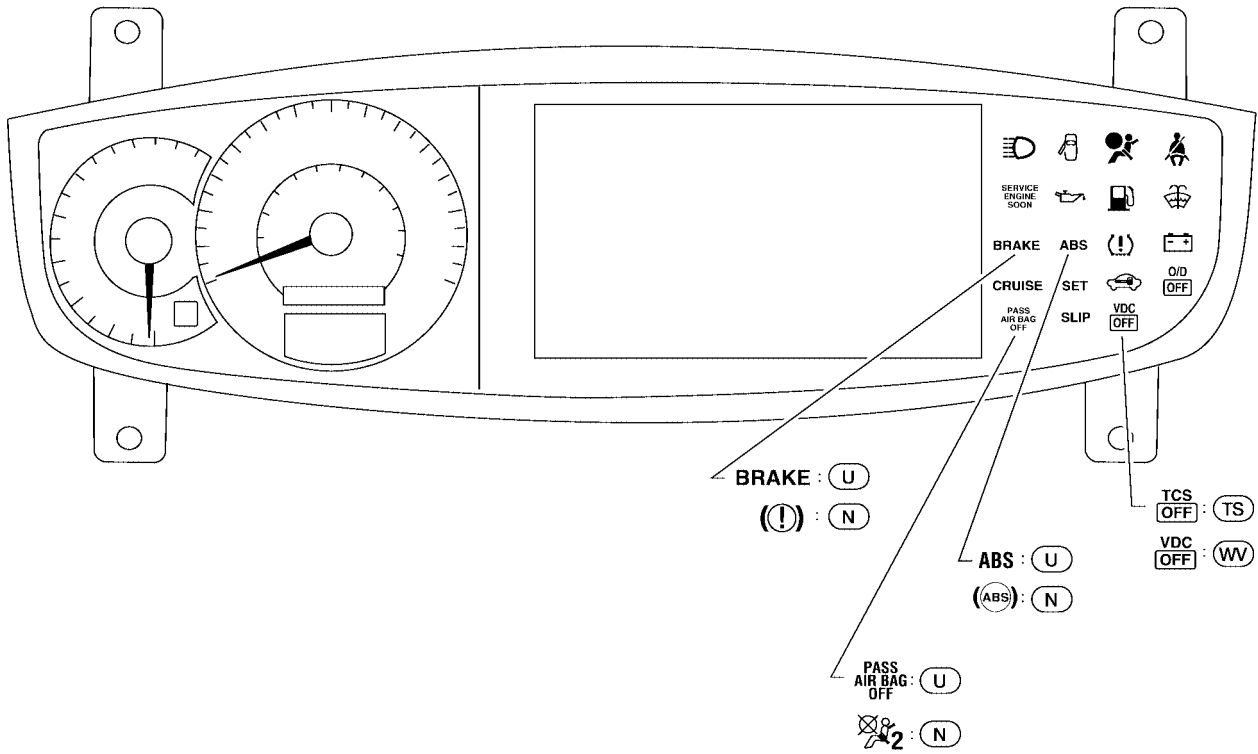

- (N) : CANADA
- (TS) : WITH TCS
- (U) : USA
- (WV) : WITH VDC

WKIA4188E

# COMBINATION METERS

## Circuit Diagram

EKS00FF2

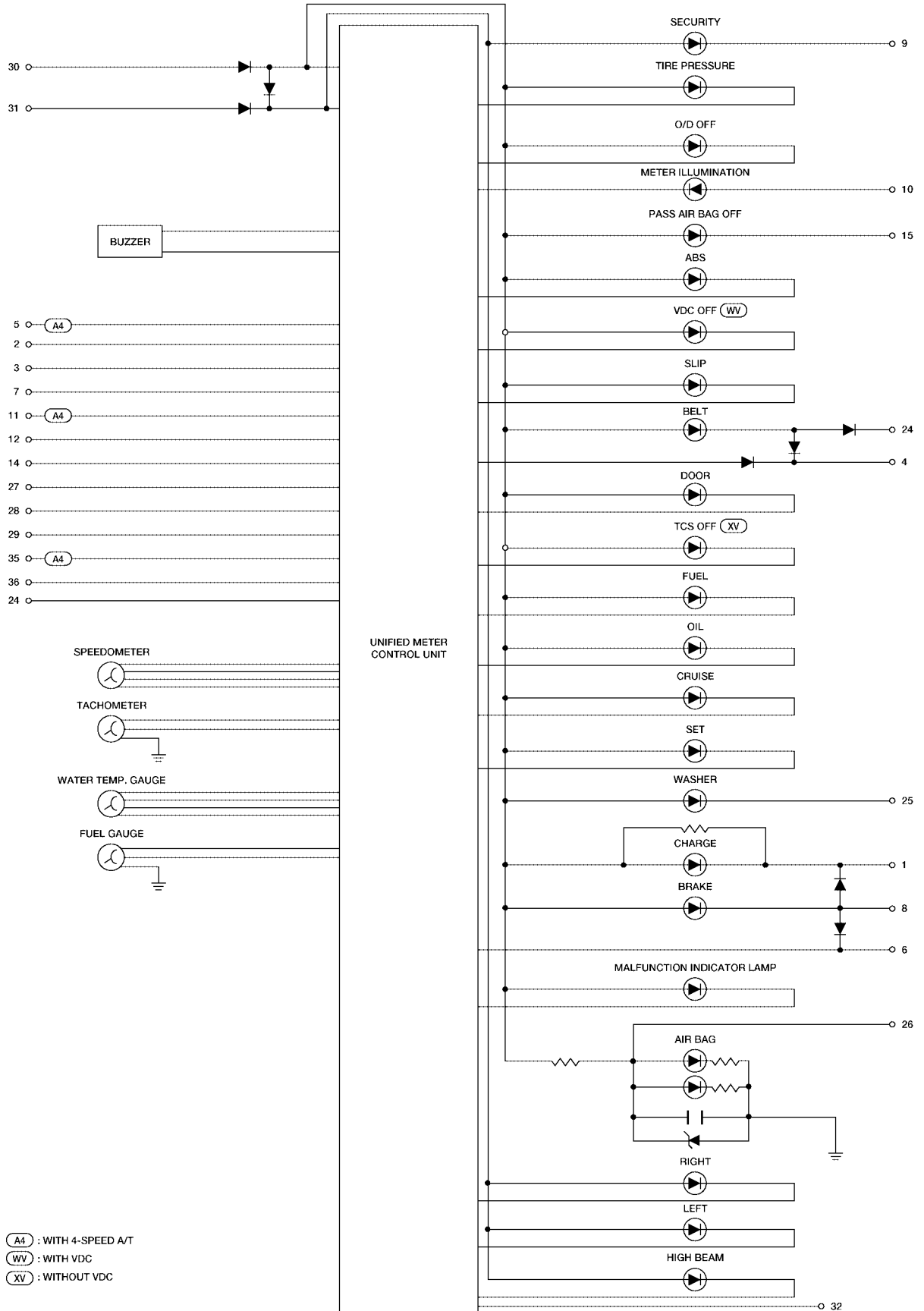

- A4 : WITH 4-SPEED A/T
- WV : WITH VDC
- XV : WITHOUT VDC

WKWA3128E



# COMBINATION METERS

## Wiring Diagram — METER —

EKS00FF3

### DI-METER-01

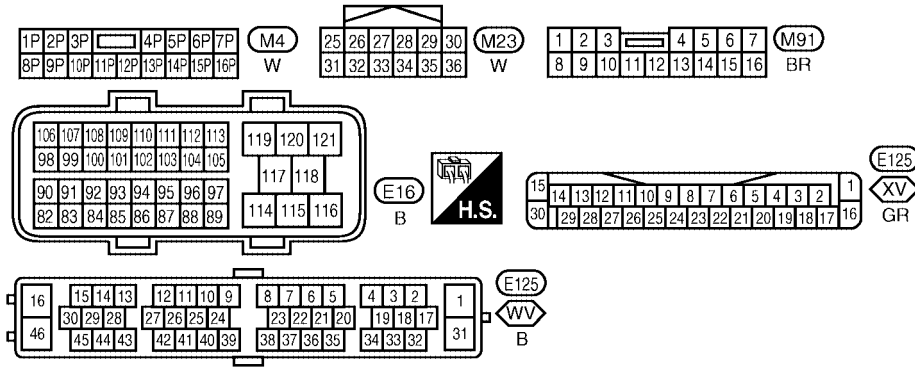
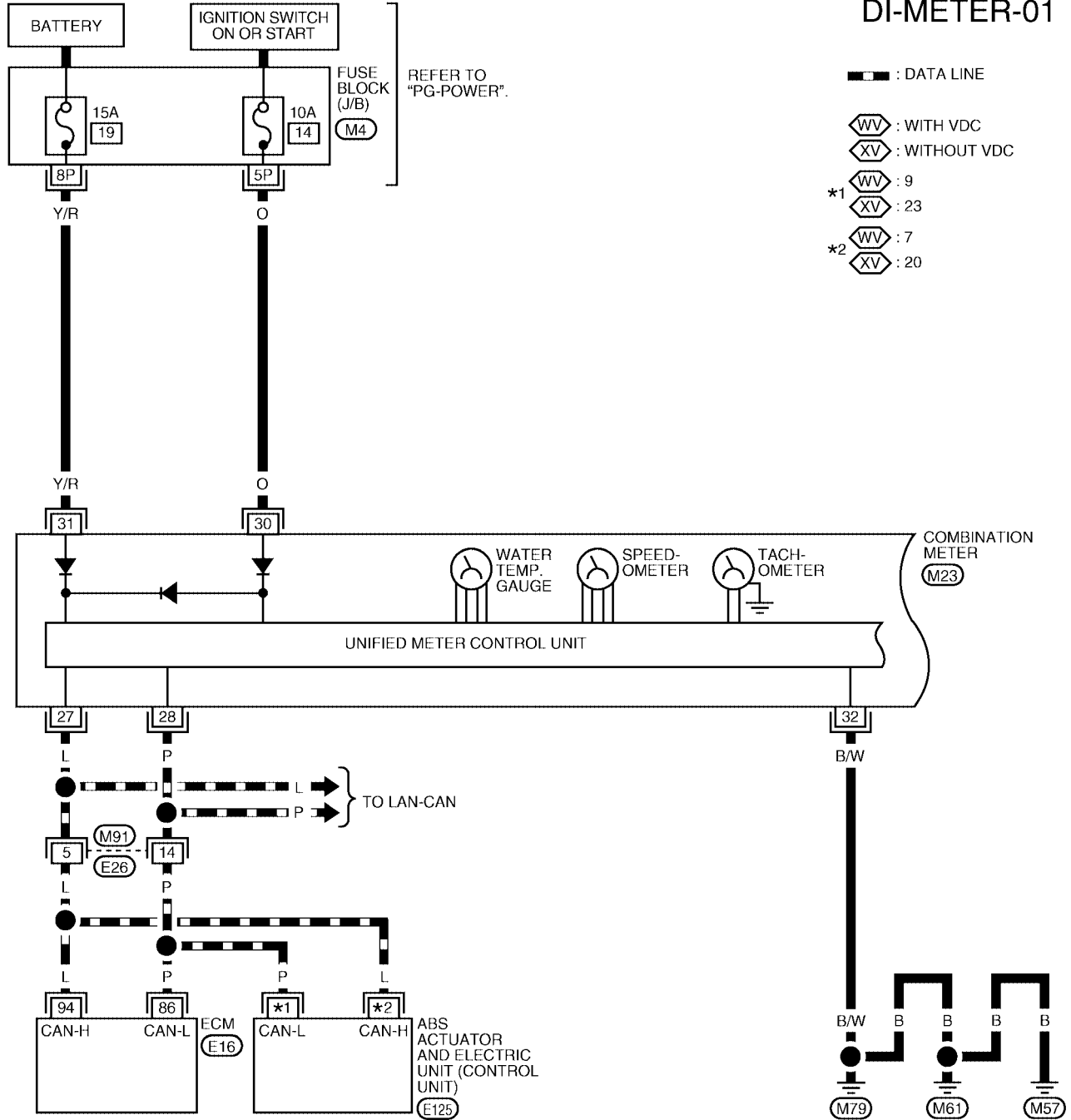

# COMBINATION METERS

DI-METER-02

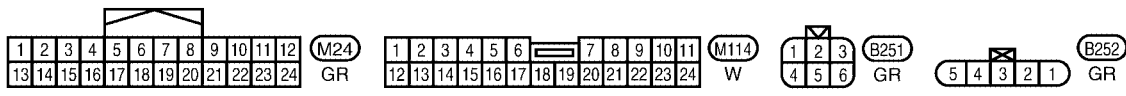
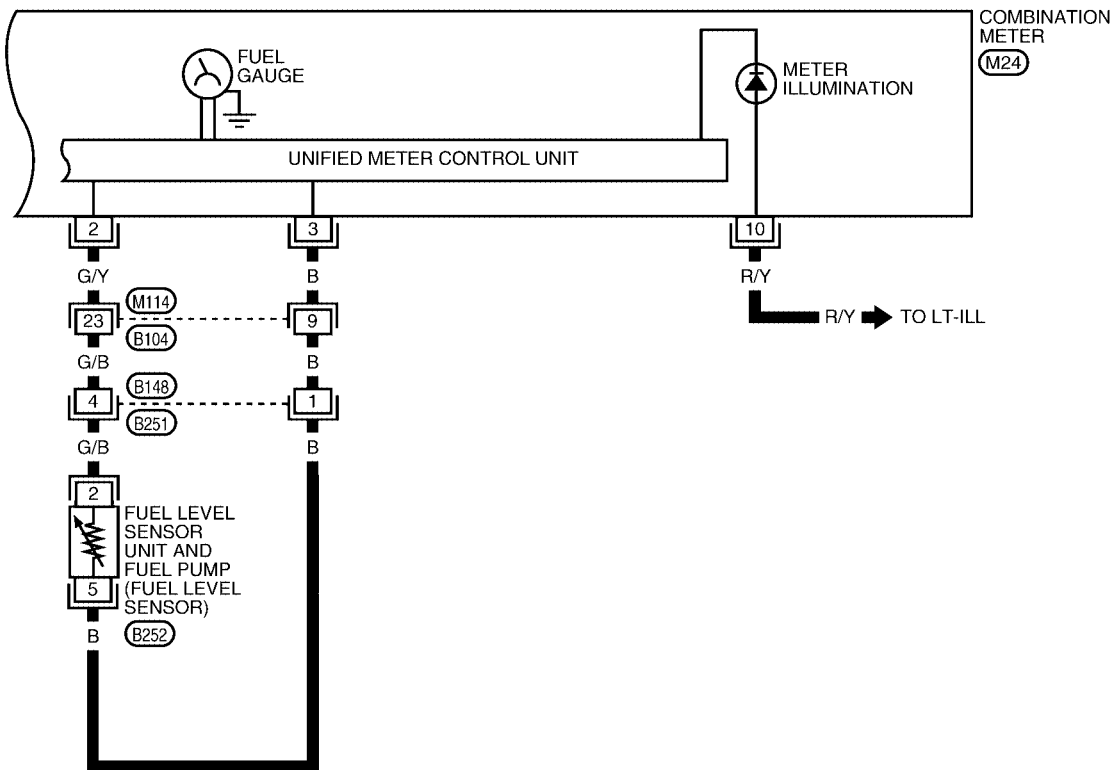

WKWA3130E

# COMBINATION METERS

## Terminals and Reference Value for Combination Meter

EKS00FF4

Terminal No.	Wire color	Item	Condition		Reference value (V) (Approx.)
			Ignition switch	Operation or condition	
2	G/Y	Fuel level sensor signal input	—	—	Refer to <a href="#">DI-17, "Fuel Level Sensor Unit Inspection"</a> .
3	B	Fuel level sensor signal output	—	—	Refer to <a href="#">DI-17, "Fuel Level Sensor Unit Inspection"</a> .
10	R/Y	Illumination control switch	—	Lighting switch ON	Refer to <a href="#">LT-163, "ILLUMINATION OPERATION BY LIGHTING SWITCH"</a> .
27	L	CAN-H	—	—	—
28	P	CAN-L	—	—	—
30	O	Ignition switch ON or START	ON	—	Battery voltage
31	Y/R	Battery power supply	OFF	—	Battery voltage
32	B/W	Ground	ON	—	0V

A  
B  
C  
D  
E  
F  
G  
H  
I  
J  
L  
M

DI

# COMBINATION METERS

EKS00FF5

## Meter/Gauge Operation and Odo/Trip Meter SELF-DIAGNOSIS FUNCTION

The following items can be checked during Combination Meter Self-Diagnosis Mode.

- Gauge sweep and present gauge values.
- Gauge input signals.
- Odometer, fuel gauge and engine temperature gauge segments.
- Illumination LEDs.
- Current odometer value stored in non-volatile memory (NVM).
- DTCs.
- Estimated present battery voltage.
- Seat belt buckle switch LH status.

### HOW TO INITIATE COMBINATION METER SELF- DIAGNOSIS MODE

**NOTE:**

Once entered, Combination Meter Self-Diagnosis Mode will function with the ignition switch in ON or START. Combination Meter Self-Diagnosis Mode will exit upon turning the ignition switch to OFF.

To initiate Combination Meter Self-Diagnosis Mode, refer to the following procedure.

1. Turn ignition switch and high beam headlamps OFF.
2. Apply brake pedal and turn ignition switch ON.
3. Within 3 seconds of turning ignition switch ON, engage flash to pass and hold for 5 to 8 seconds.

**NOTE:**

If the self-diagnosis function is activated, the odometer/trip meter will display tEst.

### COMBINATION METER SELF- DIAGNOSIS MODE FUNCTIONS

To interpret Combination Meter Self-Diagnosis Mode functions, refer to the following table.

Event	Odometer Display	Description of Test/Data	Notes:
Flash-to-pass and brake pedal held from 5 to 8 seconds or until released	tEst		Initiating self-diagnosis mode
Flash-to-pass and brake pedal held more than 8 seconds	Odometer	Does not enter Combination Meter Self-Diagnosis Mode.	
Flash-to-pass and brake pedal released within 5 to 8 seconds	GAGE	Performs sweep of all gauges, then displays present gauge values. Performs checksum tests on ROM and EE.	Initiating self-diagnosis mode
Flash to pass engaged and released = next test requested	(All segments illuminated)	Lights all A/T indicator, odometer, fuel, and engine temperature display segments.	Initiating self-diagnosis mode complete
Next test requested	bulb	Illuminates all micro-controlled lamps/LEDs regardless of SW configuration.	
Next test requested	rXXXX, FAIL	Return to normal operation of all lamps/LEDs and displays hex ROM rev. If a ROM checksum fault exists, display alternates between "r XXXX" and "FAIL".	
Next test requested	nrXXXX	Displays hex ROM rev as stored in NVM.	

# COMBINATION METERS

Event	Odometer Display	Description of Test/Data	Notes:
Next test requested	EE XX, FAIL	Hex EE level. If EE checksum fault exists, display alternates between "EE XX" and "FAIL".	
Next test requested	dtXXXX	Hex coding of final manufacturing test date.	
Next test requested	dtc, XXXX	Displays a 16 bit DTC in hex format. DTCs displayed are those detected in continuous operation, not during self-diagnosis. Display alternates between "dtc" and actual DTC ("XXXX") or "NONE".	Each select button press will cause a different DTC to be displayed until all DTC's are displayed. If there are no or no more DTC's, proceed to next function.
Next test requested	XXXXX	Raw speed value in hundredths of MPH. Speedometer indicates present speed.	Will display "-----" if message is not received. Will display "99999" if data received is invalid.
Next test requested	XXXXX	Raw speed value in hundredths of KPH. Speedometer indicates present speed.	Will display "-----" if message is not received. Will display "99999" if data received is invalid.
Next test requested	tXXXXX	Tachometer value in RPM. Tachometer indicates present RPM.	Will display "-----" if message is not received.
Next test requested	F1 XXX	Present ratioed fuel level A/D input 1 in decimal format. Fuel gauge indicates present filtered level.	000-009 = Short circuit 010-254 = Normal range 255 = Open circuit --- = Missing 5 seconds
Next test requested	FGM XXX	Fuel gauge display mode.	0xx = Normal mode xx # of segments 1xx = Expand mode xx # of segments
Next test requested	XXXC	Last temperature gauge input value in degrees C. Temperature gauge indicates present filtered temperature.	Will display "---C" if message is not received. Will display "999" if data received is invalid.
Next test requested	tGX	Temperature gauge display segments.	X = number of display segments commanded
Next test requested	BAtXX.X	Estimated present battery voltage.	
Next test requested	rES -X	Seat belt buckle switch LH status.	1 = Buckled 0 = Unbuckled
Next test requested	PA -XX to PAO -XX	Not used.	
Next test requested	GAGE		Return to beginning of self-diagnosis.

A  
B  
C  
D  
E  
F  
G  
H  
I  
J  
DI  
L  
M

# COMBINATION METERS

EKS00FF6

## How to Proceed With Trouble Diagnosis

1. Confirm the symptom or customer complaint.
2. Perform diagnosis according to diagnosis flow. Refer to [DI-14, "Diagnosis Flow"](#) .
3. According to the symptom chart, repair or replace the cause of the symptom.
4. Does the meter operate normally? If so, go to 5. If not, go to 2.
5. Inspection End.

## Diagnosis Flow

EKS00FF7

### 1. CHECK WARNING INDICATOR ILLUMINATION

1. Turn ignition switch ON.
2. Make sure warning indicators (such as malfunction indicator lamp and oil pressure warning indicator) illuminate.

Do warning indicators illuminate?

YES >> GO TO 2.

NO >> Check ignition power supply system of combination meter. Refer to [DI-15, "Power Supply and Ground Circuit Inspection"](#) .

### 2. CHECK SELF-DIAGNOSIS OPERATION OF COMBINATION METER

Perform combination meter self-diagnosis. Refer to [DI-12, "SELF-DIAGNOSIS FUNCTION"](#) .

Does self-diagnosis function operate?

YES >> GO TO 3.

NO >> Check combination meter power supply and ground circuit. Refer to [DI-15, "Power Supply and Ground Circuit Inspection"](#) .

### 3. CHECK ODOMETER, FUEL AND TEMPERATURE GAUGE OPERATION

Check segment display status of odometer, fuel and temperature gauge.

Is the display normal?

YES >> GO TO 4.

NO >> Replace the combination meter. Refer to [IP-12, "COMBINATION METER"](#) .

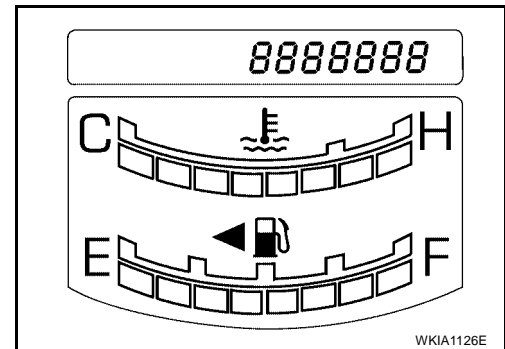

### 4. CHECK COMBINATION METER CIRCUIT

Check operation of each meter/gauge in self-diagnosis mode.

OK or NG

OK >> Go to [DI-16, "Symptom Chart"](#) .

NG >> Replace the combination meter. Refer to [IP-12, "COMBINATION METER"](#) .

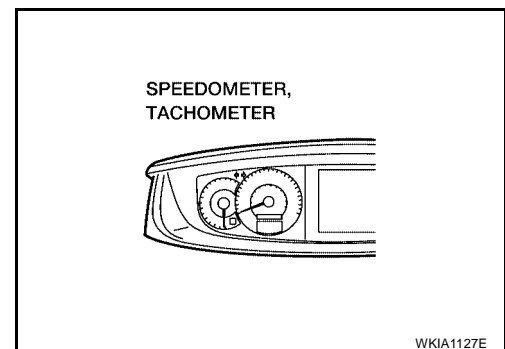

# COMBINATION METERS

EKS00FF8

## Power Supply and Ground Circuit Inspection

### 1. CHECK FUSES

Check for blown combination meter fuses.

Unit	Power source	Fuse No.
Combination meter	Battery	19
	Ignition switch ON or START	14

Refer to [DI-9, "Wiring Diagram — METER —"](#).

OK or NG

OK >> GO TO 2.

NG >> If fuse is blown, be sure to eliminate cause of malfunction before installing new fuse. Refer to [PG-4, "POWER SUPPLY ROUTING CIRCUIT"](#).

### 2. CHECK POWER SUPPLY CIRCUIT

1. Disconnect combination meter connector M23.
2. Check voltage between combination meter harness connector terminals and ground.

Terminals		(-)	Ignition switch position		
(+)	Terminal		OFF	ACC	ON
Connector	Terminal	Ground	Battery voltage	Battery voltage	Battery voltage
	M23		31	0V	0V
	30				Battery voltage

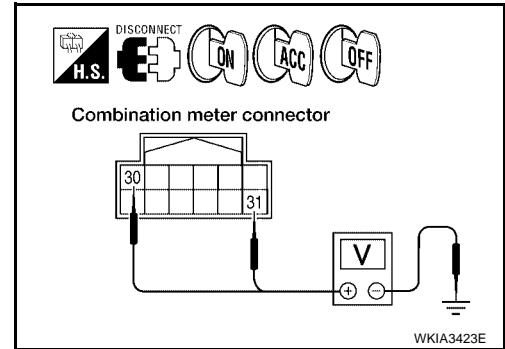

OK or NG

OK >> GO TO 3.

NG >> Check the harness for open between combination meter and fuse.

### 3. CHECK GROUND CIRCUIT

1. Turn ignition switch OFF.
2. Check continuity between combination meter harness connector terminals and ground.

Terminals		(-)	Continuity
(+)	Terminal		
Connector	Terminal	Ground	Yes
M23	32		

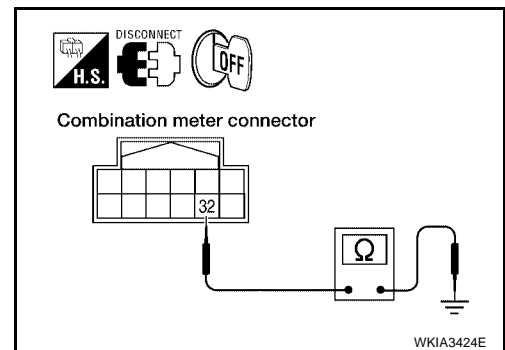

OK or NG

OK >> Inspection End.

NG >> Repair harness or connector.

# COMBINATION METERS

## Symptom Chart

EKS00FF9

Trouble phenomenon	Possible cause
Fuel warning lamp indication is irregular.	Replace combination meter. Refer to <a href="#">IP-12, "COMBINATION METER"</a> .
Improper tachometer indication.	Refer to <a href="#">DI-16, "Engine Speed Signal Inspection"</a> .
Improper water temperature gauge indication.	Refer to <a href="#">DI-16, "Water Temperature Signal Inspection"</a> .
Improper speedometer or odometer.	Refer to <a href="#">DI-16, "Vehicle Speed Signal Inspection"</a> .
Improper fuel gauge indication.	Refer to <a href="#">DI-17, "Fuel Level Sensor Unit Inspection"</a> .
More than one gauge does not give proper indication.	Replace the combination meter. Refer to <a href="#">IP-12, "COMBINATION METER"</a> .
Improper A/T position indication.	Refer to <a href="#">DI-30, "A/T INDICATOR"</a> .
Illumination control does not operate properly.	Refer to <a href="#">LT-162, "ILLUMINATION"</a> .

## Vehicle Speed Signal Inspection

EKS00FFA

### 1. CHECK ABS ACTUATOR AND ELECTRIC UNIT (CONTROL UNIT) SELF-DIAGNOSIS

Perform the ABS actuator and electric unit (control unit) self-diagnosis.

- With traction control but without VDC system, refer to [BRC-25, "SELF-DIAGNOSIS"](#) .
- With VDC system, refer to [BRC-72, "SELF-DIAGNOSIS"](#) .

#### OK or NG

- OK >> Replace the combination meter. Refer to [IP-12, "COMBINATION METER"](#) .
- NG >> Perform "Diagnostic Procedure" for displayed DTC.

## Water Temperature Signal Inspection

EKS00FFB

### 1. CHECK ECM SELF-DIAGNOSIS

Perform ECM self-diagnosis. Refer to [EC-125, "SELF-DIAG RESULTS MODE"](#) .

#### OK or NG

- OK >> Replace the combination meter. Refer to [IP-12, "COMBINATION METER"](#) .
- NG >> Perform "Diagnostic procedure" for displayed DTC.

## Engine Speed Signal Inspection

EKS00FFC

### 1. CHECK ECM SELF-DIAGNOSIS

Perform ECM self-diagnosis. Refer to [EC-125, "SELF-DIAG RESULTS MODE"](#) .

#### OK or NG

- OK >> Replace the combination meter. Refer to [IP-12, "COMBINATION METER"](#) .
- NG >> Perform "Diagnostic procedure" for displayed DTC.



# COMBINATION METERS

EKS00FFD

## Fuel Level Sensor Unit Inspection

### FUEL LEVEL SENSOR UNIT

The following symptoms do not indicate a malfunction.

- Depending on vehicle position or driving circumstance, the fuel in the tank shifts and the indication may fluctuate.
- If the vehicle is fueled with the ignition switch ON, the indication will update slowly.
- If the vehicle is tilted when the ignition switch is turned ON, fuel in the tank may flow to one direction resulting in a change of reading.

### LOW-FUEL WARNING LAMP

Depending on vehicle posture or driving circumstances, the fuel level in the tank varies, and the warning lamp ON timing may be changed.

### 1. CHECK SELF-DIAGNOSIS

Perform combination meter self-diagnosis. Refer to [DI-12, "SELF-DIAGNOSIS FUNCTION"](#) .

OK or NG

OK >> GO TO 2.

NG >> Replace the combination meter. Refer to [IP-12, "COMBINATION METER"](#) .

### 2. CHECK HARNESS CONNECTOR

1. Turn the ignition switch OFF.
2. Check combination meter and fuel level sensor unit and fuel pump terminals (meter-side and harness-side) for poor connection and damaged terminals.

OK or NG

OK >> GO TO 3.

NG >> Repair or replace terminals or connectors.

### 3. CHECK HARNESS CONNECTOR OUTPUT SIGNAL

1. Disconnect fuel level sensor unit and fuel pump connector.
2. Turn ignition switch ON.
3. Check voltage between combination meter harness connector M24 terminal 2 and ground.

**Battery voltage should exist.**

OK or NG

OK >> GO TO 4.

NG >> Replace the combination meter. Refer to [IP-12, "COMBINATION METER"](#) .

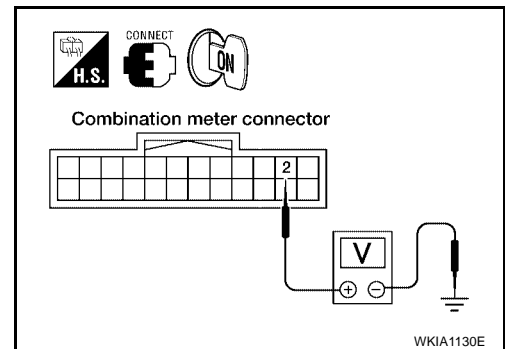

# COMBINATION METERS

## 4. CHECK HARNESS FOR OPEN OR SHORT CIRCUIT

1. Turn ignition switch OFF.
2. Disconnect combination meter connector M24.
3. Check continuity between combination meter harness connector M24 terminal 2 and fuel level sensor unit and fuel pump harness connector B252 terminal 2.

**Continuity should exist.**

4. Check continuity between fuel level sensor unit and fuel pump harness connector B252 terminal 2 and ground.

**Continuity should not exist.**

OK or NG

OK >> GO TO 5.

NG >> Repair harness or connector.

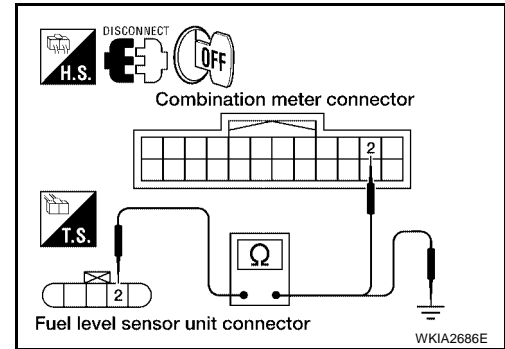

## 5. CHECK FUEL LEVEL SENSOR CIRCUIT

1. Check continuity between combination meter harness connector M24 terminal 3 and fuel level sensor unit and fuel pump harness connector B252 terminal 5.

**Continuity should exist.**

2. Check continuity between fuel level sensor unit and fuel pump harness connector B252 terminal 5 and ground.

**Continuity should not exist.**

OK or NG

OK >> GO TO 6.

NG >> Repair harness or connector.

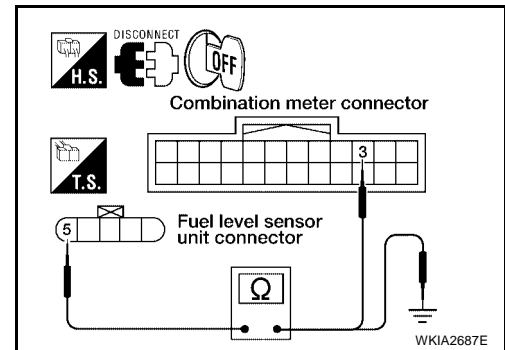

## 6. CHECK INSTALLATION CONDITION

Check fuel level sensor unit installation, and determine whether the float arm interferes or binds with any of the internal components in the fuel tank.

OK or NG

OK >> GO TO 7.

NG >> Install the fuel level sensor unit properly.

## 7. CHECK FUEL LEVEL SENSOR UNIT

Check the fuel level sensor unit. Refer to [DI-20, "FUEL LEVEL SENSOR UNIT CHECK"](#).

OK or NG

OK >> Replace the combination meter. Refer to [IP-12, "COMBINATION METER"](#).

NG >> Replace the fuel level sensor unit. Refer to [FL-5, "Removal and Installation"](#).

# COMBINATION METERS

## Fuel Gauge Fluctuates, Indicates Wrong Value, or Varies

EKS00FFE

### 1. CHECK FUEL GAUGE FLUCTUATION

Test drive vehicle to see if gauge fluctuates only during driving or just before or just after stopping.

Does the indication value vary only during driving or just before or just after stopping?

YES >> The fluctuation may be caused by fuel level change in the fuel tank. Condition is normal.

NO >> Ask the customer about the situation when the symptom occurs in detail, and perform the trouble diagnosis.

## Fuel Gauge Does Not Move to Full-position

EKS00FFF

### 1. CHECK POINTER MOVEMENT TO FULL-POSITION

Does it take a long time for the pointer to move to full-position?

YES or NO

YES >> GO TO 2.

NO >> GO TO 3.

### 2. CHECK IGNITION SWITCH POSITION

Was the vehicle fueled with the ignition switch ON?

YES or NO

YES >> Be sure to fuel the vehicle with the ignition switch OFF. Otherwise, it will take a long time for the pointer to move to full-position because of the characteristic of the fuel gauge.

NO >> GO TO 3.

### 3. OBSERVE VEHICLE POSITION

Is the vehicle parked on an incline?

YES or NO

YES >> Check the fuel level indication with vehicle on a level surface.

NO >> GO TO 4.

### 4. CHECK POINTER MOVEMENT TO EMPTY-POSITION

During driving, does the fuel gauge move gradually toward empty-position?

YES or NO

YES >> Check the fuel level sensor unit. Refer to [DI-20, "FUEL LEVEL SENSOR UNIT CHECK"](#).

NO >> Check fuel level sensor unit installation, and determine whether the float arm interferes or binds with any of the internal components in the fuel tank.

A

B

C

D

E

F

G

H

I

J

DI

L

M

# COMBINATION METERS

## Electrical Components Inspection FUEL LEVEL SENSOR UNIT CHECK

EKS00FFG

For removal, refer to [FL-5, "Removal and Installation"](#) .

### Check Fuel Level Sensor Unit and Fuel Pump

Check resistance between fuel level sensor unit and fuel pump connector terminals 2 and 5.

Terminals		Float position		mm (in)	Resistance value $\Omega$ (Approx.)
2	5	*1	Empty	15 (0.59)	81
		*2	Full	193 (7.6)	2

\*1 and \*2: When float rod is in contact with stopper.

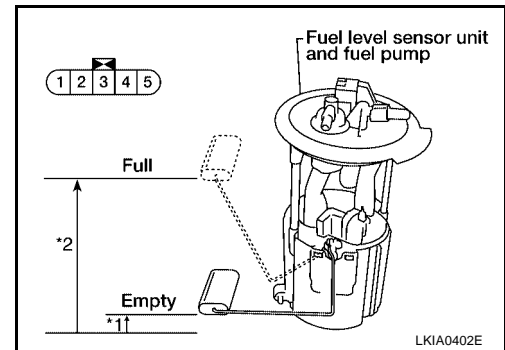

EKS00FFH

## Combination Meter REMOVAL AND INSTALLATION

Refer to [IP-12, "COMBINATION METER"](#) .

# WARNING LAMPS

## WARNING LAMPS

### Schematic

PF2:24814

EKS00FFI

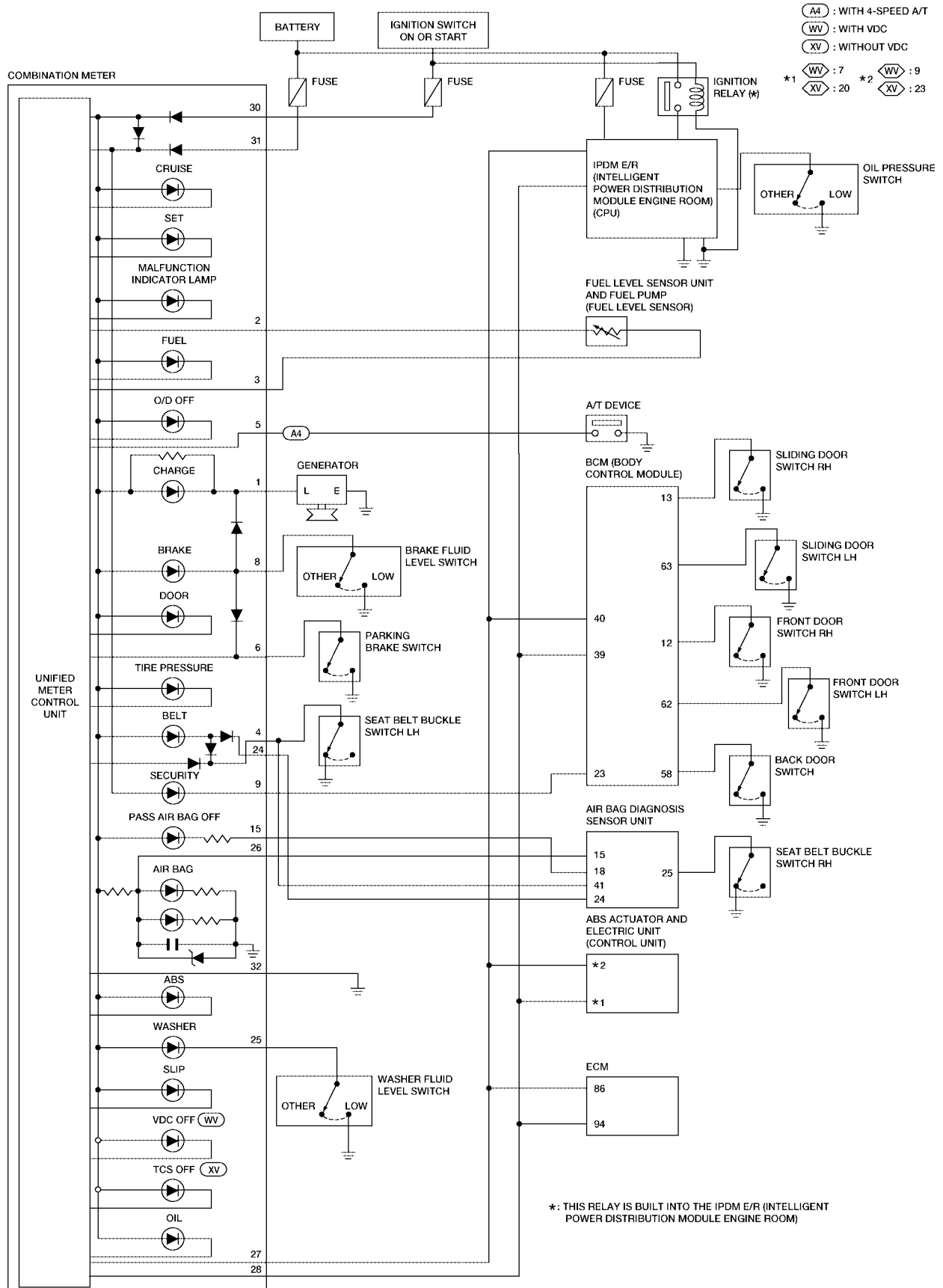

WKWA3131E

A  
B  
C  
D  
E  
F  
G  
H  
I  
J  
K  
L  
M

DI

# WARNING LAMPS

## Wiring Diagram — WARN —

EKS00FFJ

### DI-WARN-01

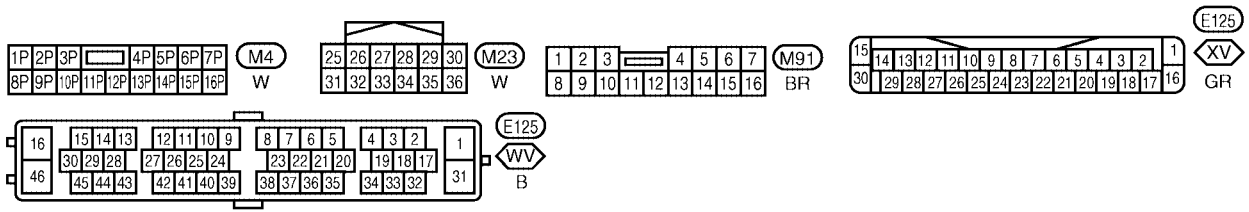
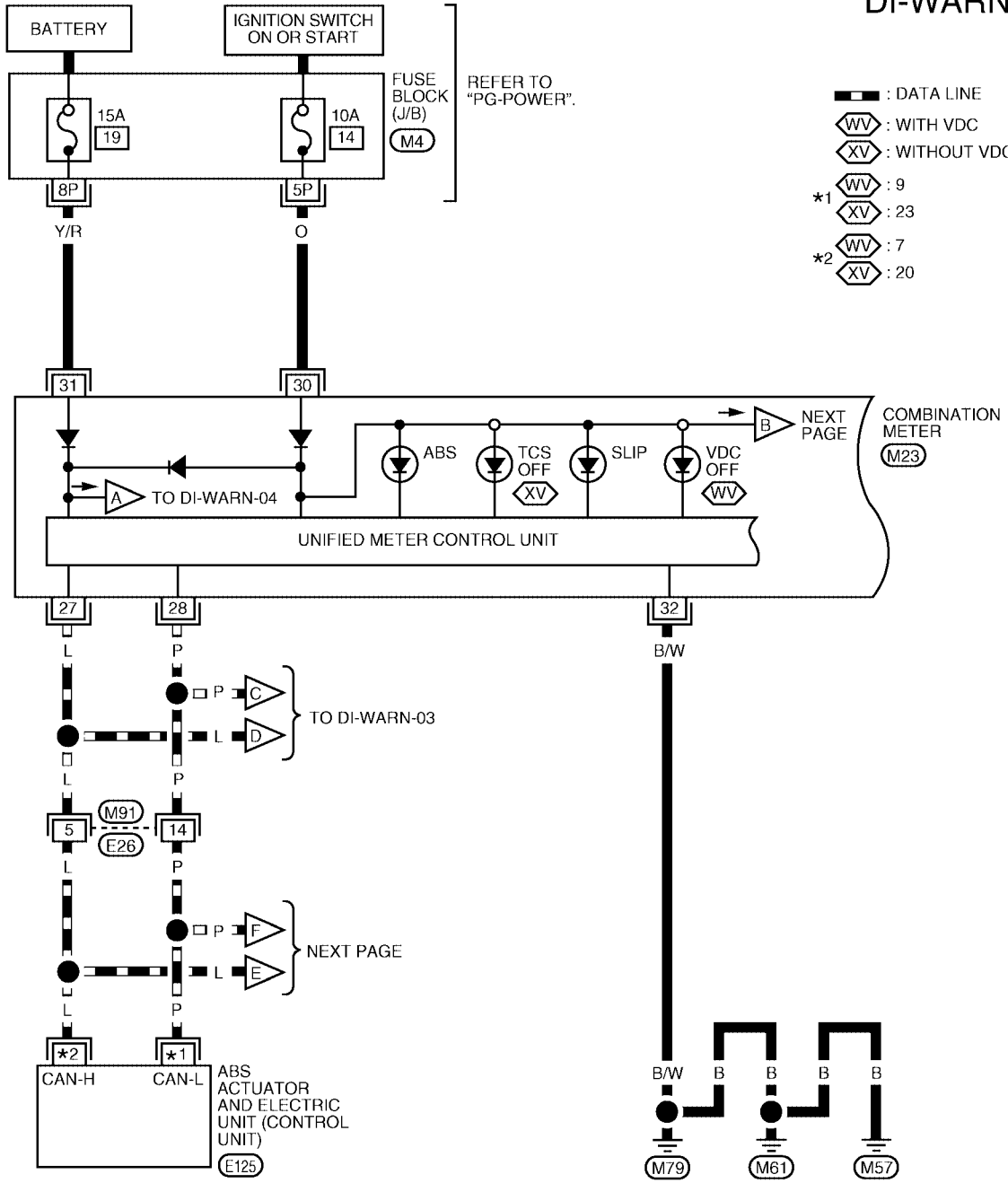

WKWA3132E

# WARNING LAMPS

DI-WARN-02

**A4** : WITH 4-SPEED A/T

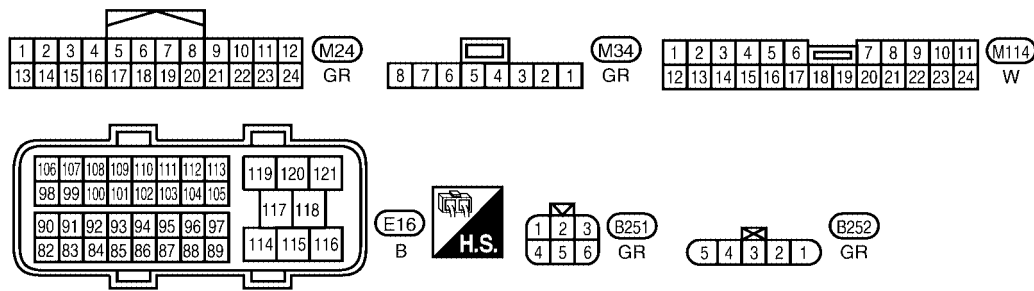
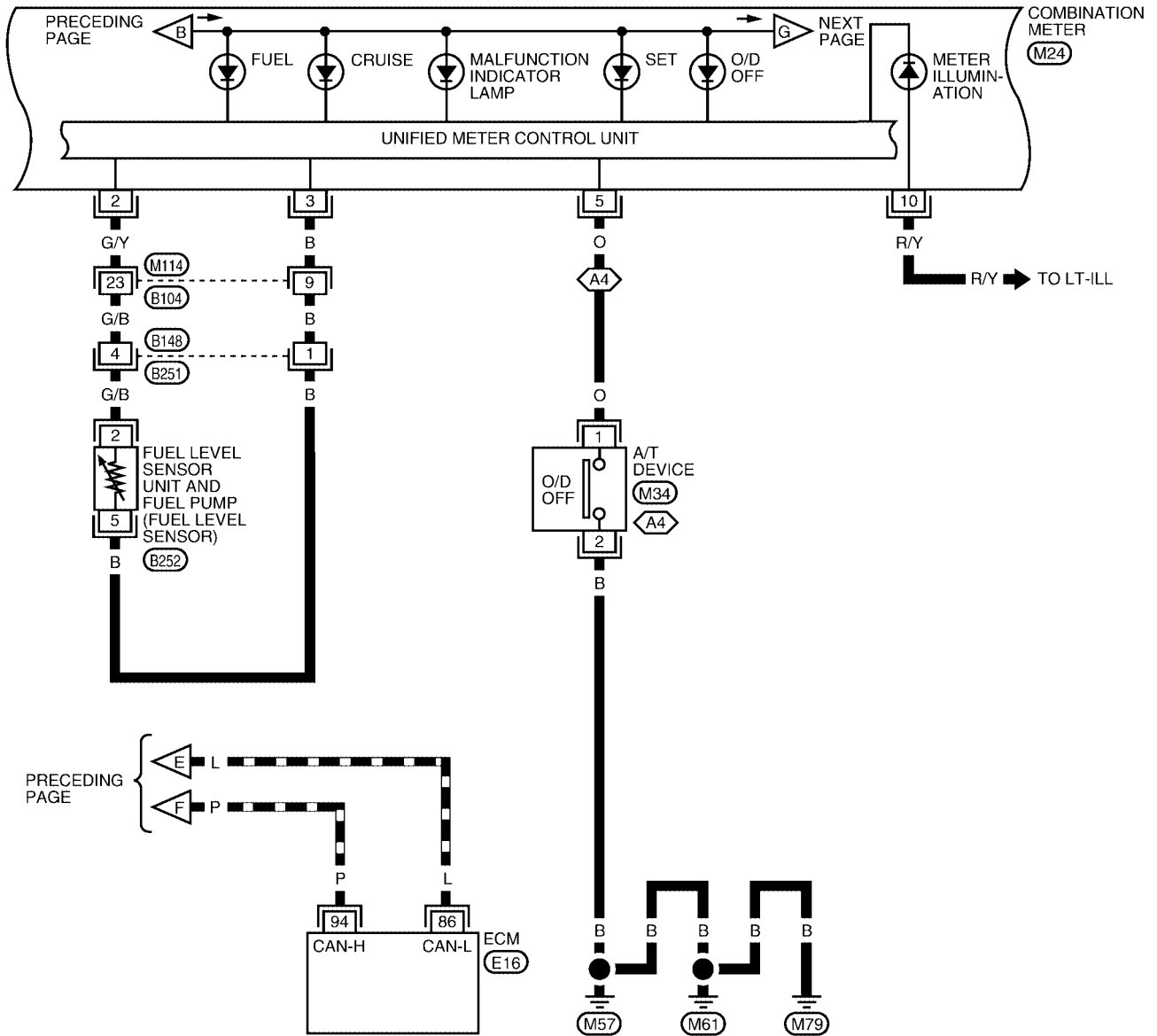

WKWA3133E

# WARNING LAMPS

DI-WARN-03

▬ : DATA LINE

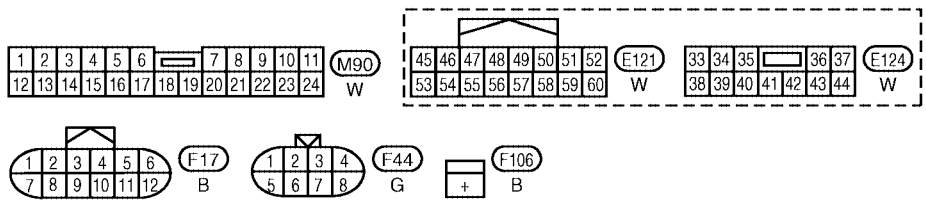
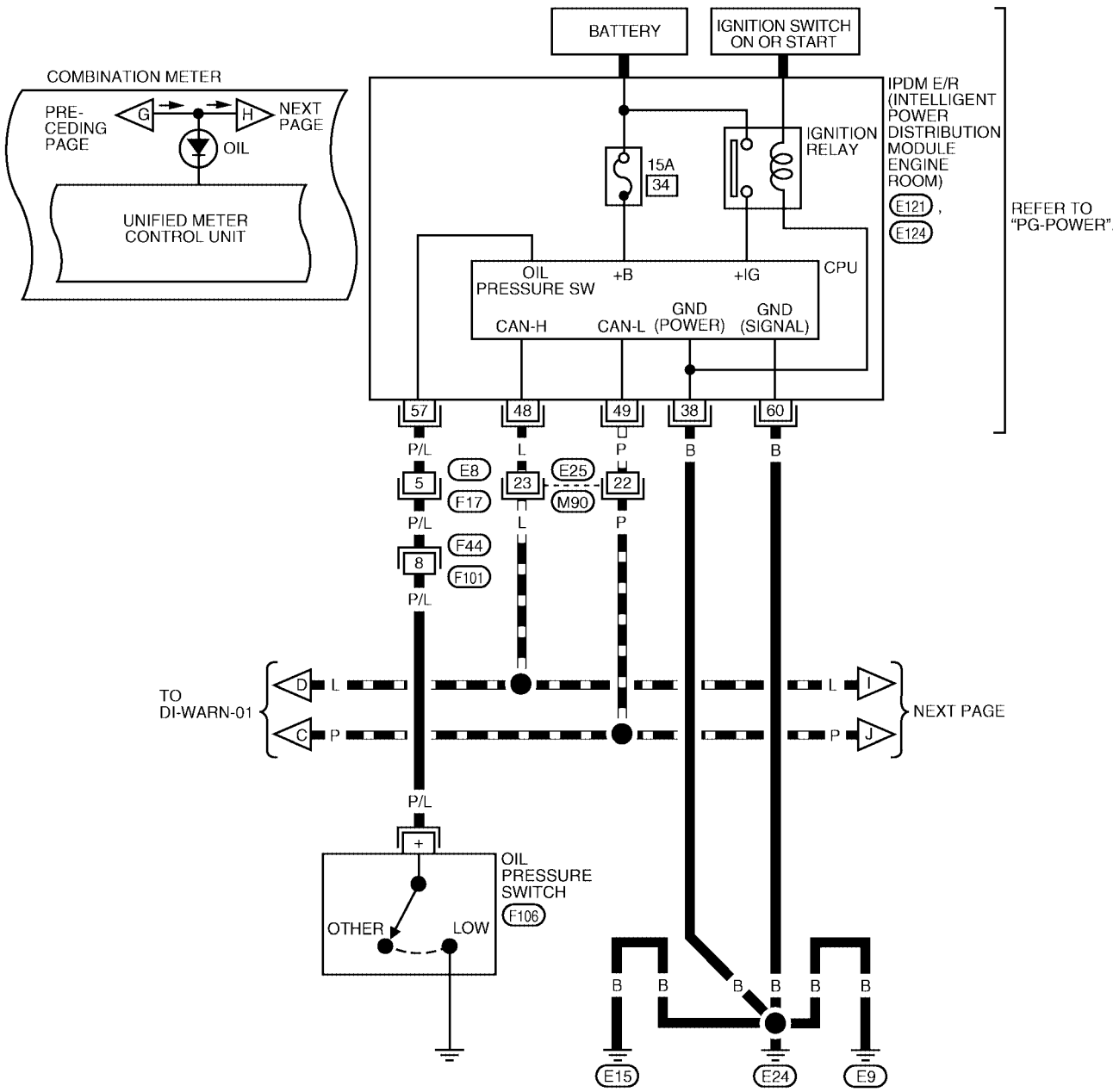

WKWA3134E





# WARNING LAMPS

DI-WARN-05

WV : WITH VDC

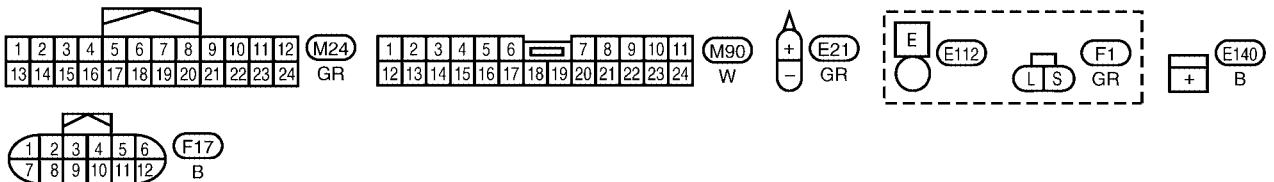
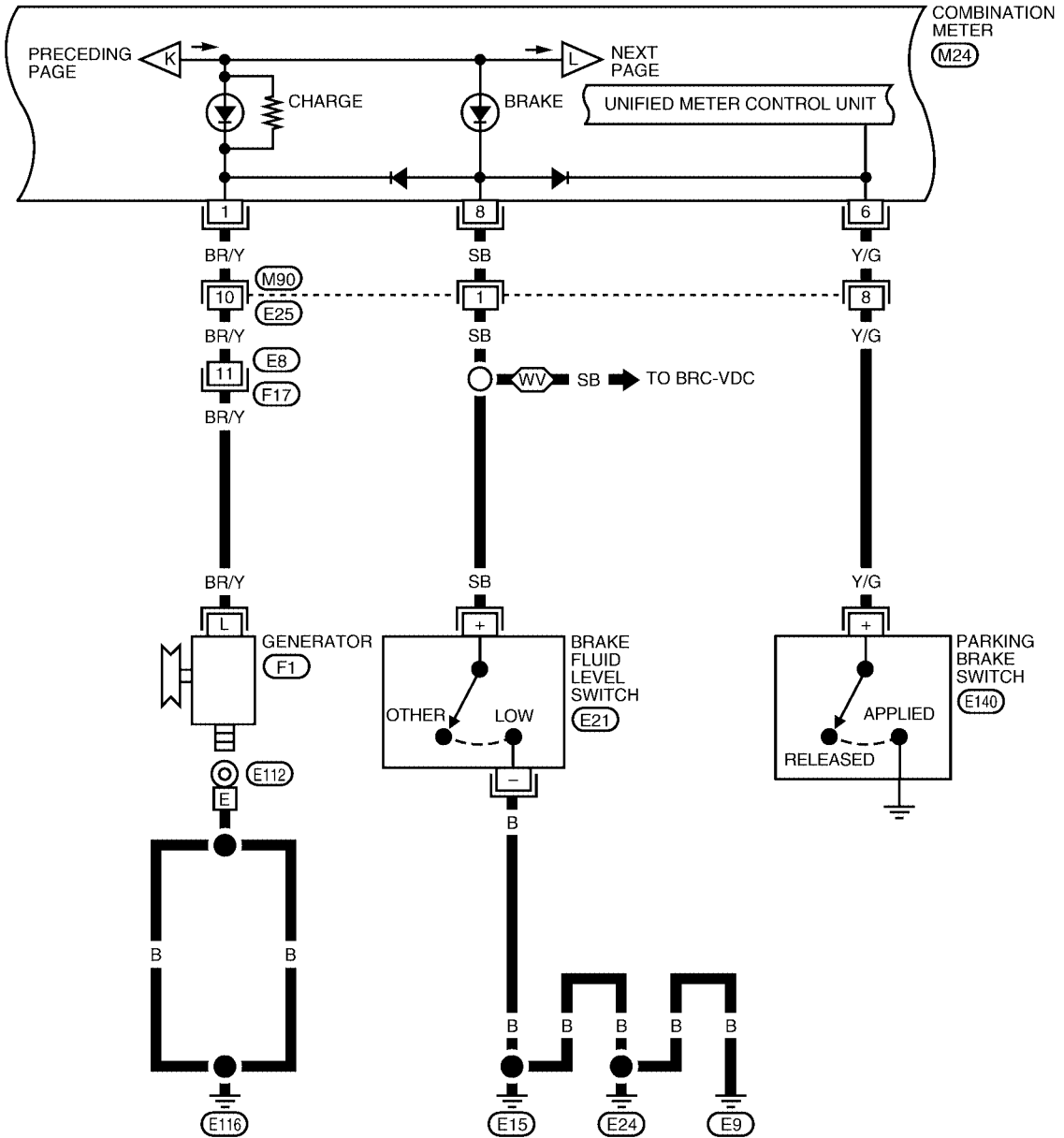

WKWA3136E

# WARNING LAMPS

DI-WARN-06

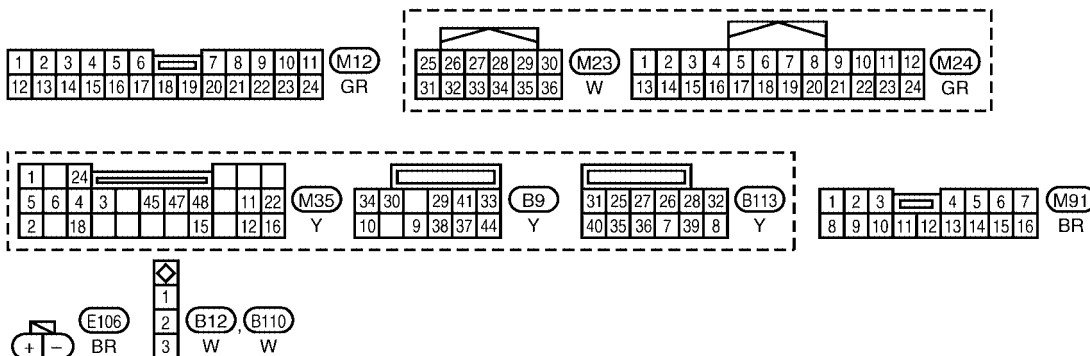
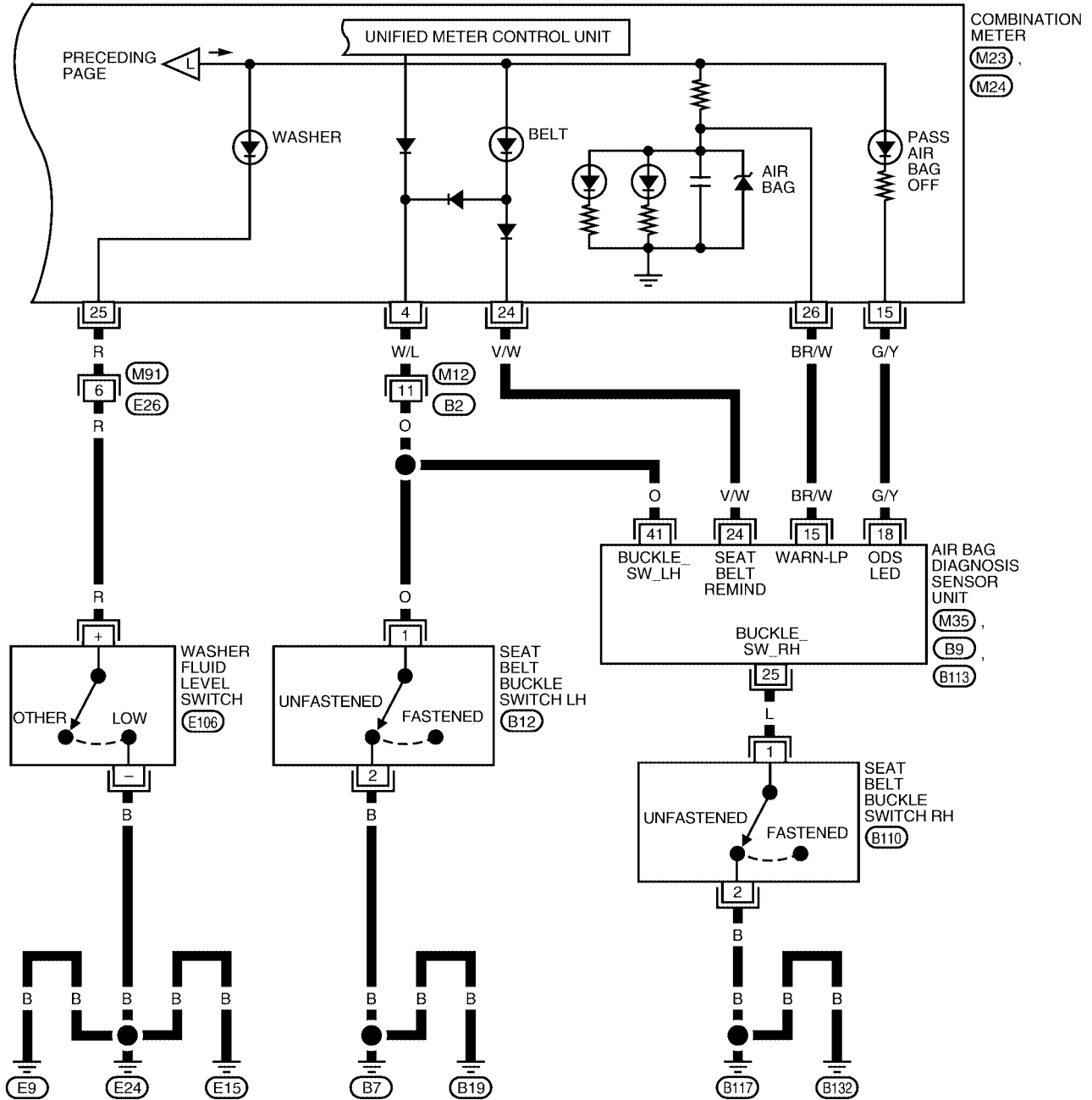

WKWA3137E

# WARNING LAMPS

EKS00FFK

## Oil Pressure Warning Lamp Stays Off (Ignition Switch ON)

### 1. CHECK IPDM E/R OUTPUT SIGNAL

Activate IPDM E/R auto active test. Refer to [PG-22, "Auto Active Test"](#).

Is oil pressure warning lamp blinking?

- YES >> GO TO 4.
- NO >> GO TO 2.

### 2. CHECK BCM INPUT SIGNAL

Select "DATA MONITOR" of "SIGNAL BUFFER". Refer to [BCS-11, "CONSULT-II Function \(BCM\)"](#). Operate ignition switch with "OIL PRESS SW" of data monitor and check operation status.

**When ignition switch is in ON : OIL PRESS SW ON position (Engine stopped)**

**When engine running : OIL PRESS SW OFF**

OK or NG

- OK >> Replace the combination meter. Refer to [IP-12, "COMBINATION METER"](#).
- NG >> GO TO 3.

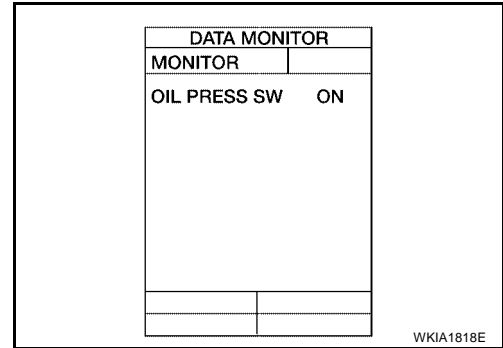

### 3. CHECK IPDM E/R INPUT SIGNAL

Select "DATA MONITOR" of "IPDM E/R". Refer to [BCS-11, "CONSULT-II Function \(BCM\)"](#). Operate ignition switch with "OIL P SW" of data monitor and check operation status.

**When ignition switch is in ON : OIL P SW CLOSE position (Engine stopped)**

**When engine running : OIL P SW OPEN**

OK or NG

- OK >> Replace the BCM. Refer to [BCS-20, "Removal and Installation of BCM"](#).
- NG >> Replace the IPDM E/R. Refer to [PG-29, "Removal and Installation of IPDM E/R"](#).

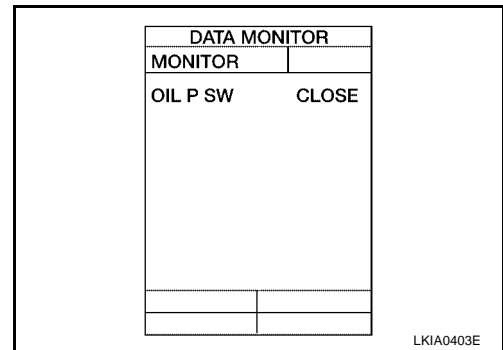

### 4. CHECK OIL PRESSURE SWITCH CIRCUIT

1. Turn ignition switch OFF.
2. Disconnect IPDM E/R connector E121 and oil pressure switch connector F106.
3. Check continuity between IPDM E/R harness connector E121 terminal 57 and oil pressure switch harness connector F106 terminal +.

**Continuity should exist.**

OK or NG

- OK >> GO TO 5.
- NG >> Repair harness or connector.

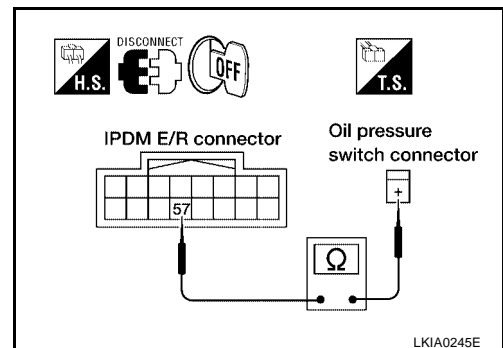

# WARNING LAMPS

## 5. CHECK OIL PRESSURE SWITCH

Check oil pressure switch. Refer to [DI-29, "OIL PRESSURE SWITCH"](#) .

OK or NG

- OK >> Replace the IPDM E/R. Refer to [PG-29, "Removal and Installation of IPDM E/R"](#) .
- NG >> Replace the oil pressure switch.

### Oil Pressure Warning Lamp Does Not Turn Off (Oil Pressure Is Normal)

EKS00FFL

**NOTE:**

For oil pressure inspection, refer to [LU-7, "ENGINE OIL PRESSURE CHECK"](#) .

#### 1. CHECK OIL PRESSURE SWITCH CIRCUIT

1. Turn ignition switch OFF.
2. Disconnect IPDM E/R connector E121 and oil pressure switch connector F106.
3. Check continuity between IPDM E/R harness connector E121 terminal 57 and ground.

Continuity should not exist.

OK or NG

- OK >> GO TO 2.
- NG >> Repair harness or connector.

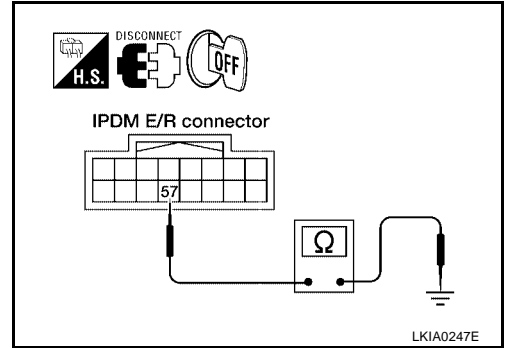

#### 2. CHECK OIL PRESSURE SWITCH

Check oil pressure switch. Refer to [DI-29, "OIL PRESSURE SWITCH"](#) .

OK or NG

- OK >> Replace IPDM E/R. Refer to [PG-29, "Removal and Installation of IPDM E/R"](#) .
- NG >> Replace oil pressure switch.

### Component Inspection OIL PRESSURE SWITCH

EKS00FFM

Check continuity between oil pressure switch and ground.

Condition	Oil pressure kPa (kg/cm <sup>2</sup> , psi)	Continuity
Engine stopped	Less than 29 (0.3, 4)	Yes
Engine running	More than 29 (0.3, 4)	No

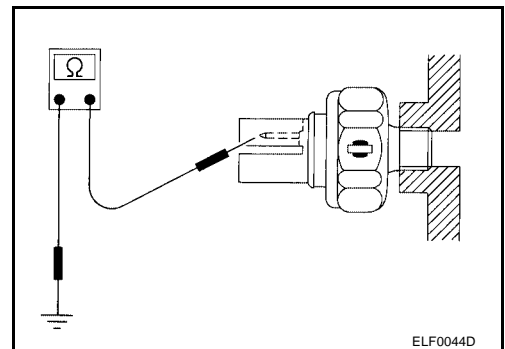



# A/T INDICATOR

## 5 SPEED A/T

DI-AT/IND-02

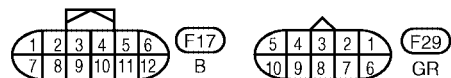
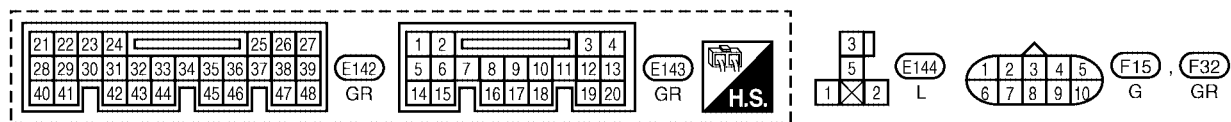
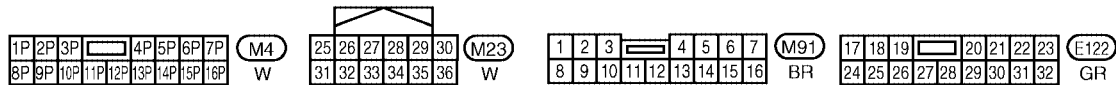
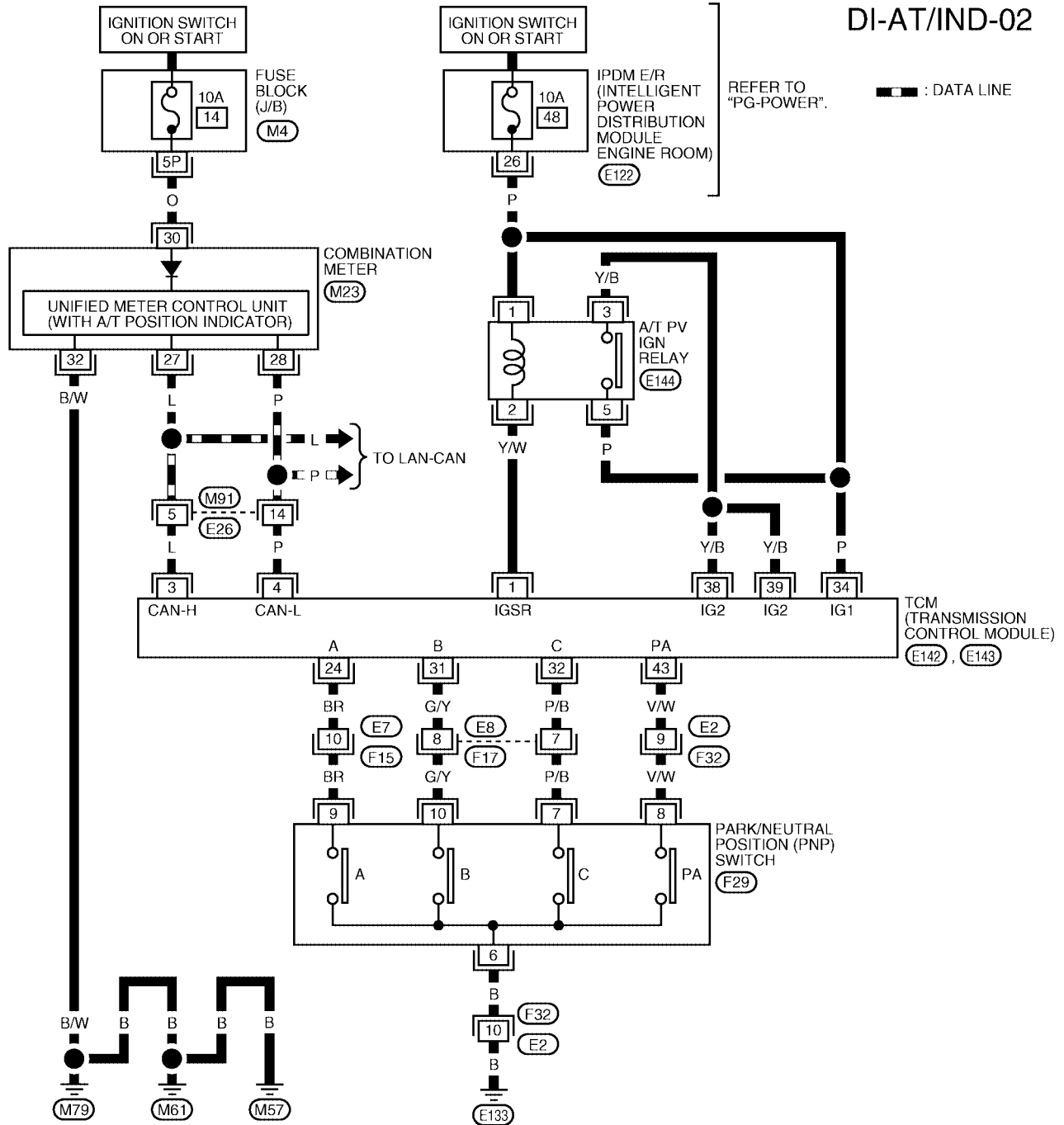

WKWA3139E

# A/T INDICATOR

## Trouble Diagnosis

EKS00FFO

### A/T Indicator Does Not Illuminate

EKS00FFP

#### 1. CHECK SELF-DIAGNOSIS OF COMBINATION METER

Perform combination meter self-diagnosis. Refer to [DI-12, "SELF-DIAGNOSIS FUNCTION"](#) .

OK or NG

OK >> GO TO 2.

NG >> Replace combination meter. Refer to [IP-12, "COMBINATION METER"](#) .

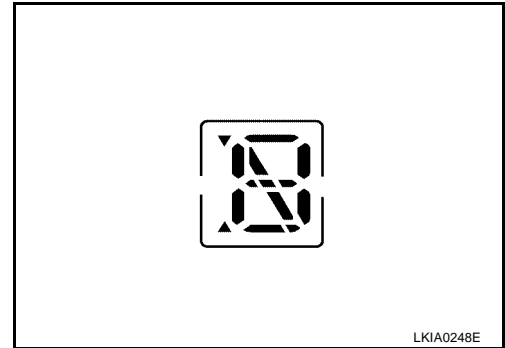

#### 2. CHECK TCM

Perform self-diagnosis of TCM. For 4-speed A/T models, refer to [AT-47, "SELF-DIAGNOSTIC RESULT TEST MODE"](#) . For 5-speed A/T models, refer to [AT-440, "SELF-DIAG RESULT MODE"](#) .

OK or NG

OK >> Replace combination meter. Refer to [IP-12, "COMBINATION METER"](#) .

NG >> Check the applicable parts.



# WARNING CHIME

PFP:24814

## WARNING CHIME

### Component Parts and Harness Connector Location

EKS00FFQ

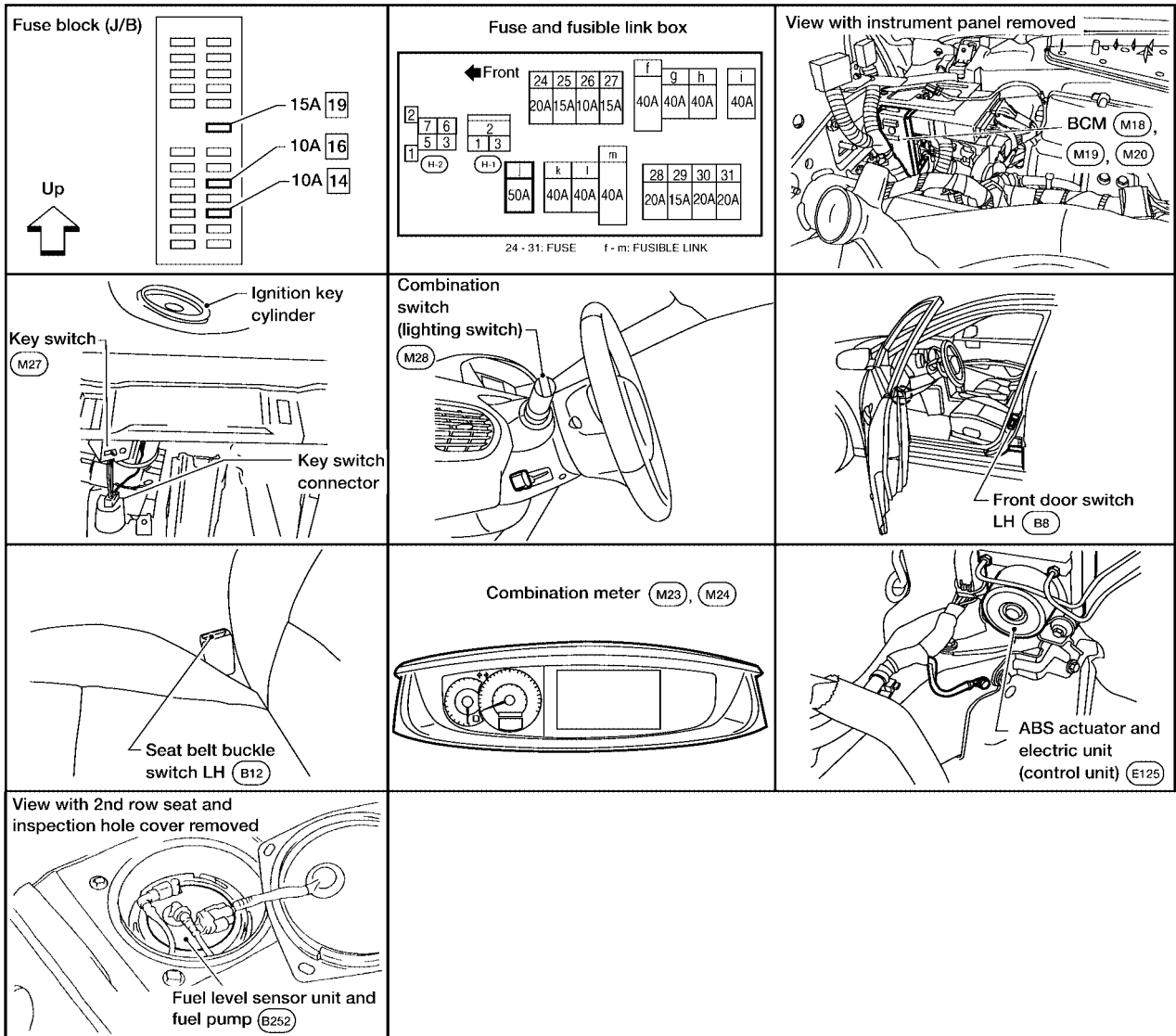

A  
B  
C  
D  
E  
F  
G  
H  
I  
J  
DI  
L  
M

# WARNING CHIME

EKS00FFR

## System Description

### FUNCTION

Power is supplied at all times

- through 50A fuse (letter j , located in the fuse and fusible link box)
- to BCM terminal 55, and
- through 15A fuse [No. 19, located in the fuse block (J/B)]
- to key switch terminal 1.

With ignition switch in ON or START position, power is supplied

- through 10A fuse [No. 16, located in the fuse block (J/B)]
- to BCM terminal 38.

Ground is supplied

- to BCM terminal 52
- through body grounds M57, M61, and M79.

### NOTE:

When ignition key warning chime, light warning chime, and seat belt warning chime are required at the same time, the priorities for each chime are the following.

1. Light warning chime
2. Ignition key warning chime
3. Seat belt warning chime

### IGNITION KEY WARNING CHIME

With the key inserted in the ignition switch, the ignition switch in OFF position, and the driver's door open, the warning chime will sound.

Power is supplied

- through key switch terminal 2
- to BCM terminal 37.

Ground is supplied

- to BCM terminal 62
- through front door switch LH terminal 1.

Front door switch LH is case grounded.

BCM detects key inserted into the ignition switch, and sends key warning signal to combination meter via CAN communication lines. When combination meter receives key warning signal, it sounds warning chime.

### LIGHT WARNING CHIME

With the key removed from the ignition switch, the driver's door open, and the lighting switch (part of the combination switch) in 1st or 2nd position, the warning chime will sound. [This is the operation of the light warning chime, except when headlamp battery saver control operates (for 5 minutes after ignition switch is turned to OFF or ACC position) and headlamps do not illuminate.]

Signal is supplied

- from combination switch (lighting switch) terminals 1, 2, 3, 4, 5, 6, 7, 8, 9 and 10
- to BCM terminals 2, 3, 4, 5, 6, 32, 33, 34, 35 and 36.

### NOTE:

BCM detected lighting switch in 1st or 2nd position. Refer to [BCS-3, "COMBINATION SWITCH READING FUNCTION"](#) .

Ground is supplied

- to BCM terminal 62
- through front door switch LH terminal 1.

Front door switch LH is case grounded.

BCM detects headlamps are illuminated, and sends light warning signal to combination meter via CAN communication lines. When combination meter receives light warning signal, it sounds warning chime.

### SEAT BELT WARNING CHIME

When the ignition switch is turned ON with the seat belt unfastened (seat belt buckle switch LH unfastened), warning chime will sound for approximately 6 seconds.

# WARNING CHIME

Ground is supplied

- to combination meter terminal 4
- through seat belt buckle switch LH terminal 1.

Seat belt buckle switch LH terminal 2 is grounded through body grounds B7 and B19.

Combination meter sends seat belt buckle switch LH unfastened signal to BCM via CAN communication line. BCM receives seat belt buckle switch LH unfastened signal from combination meter via CAN communication line, and sends seat belt warning signal to combination meter via CAN communication line. When the combination meter receives the seat belt warning signal, it sounds the warning chime. The BCM controls the (6 second) duration of the seat belt warning chime.

## LOW FUEL WARNING CHIME

When the low fuel warning lamp initially comes on, a warning chime will sound. If the warning lamp turns off while driving and then turns on again, the chime will not sound a second time. The chime will only sound once during an ignition cycle.

A variable resistor signal is supplied

- to combination meter terminal 3
- through fuel level sensor unit and fuel pump terminal 5
- through fuel level sensor unit and fuel pump terminal 2
- from combination meter terminal 2.

## CAN Communication System Description

EKS00FFS

Refer to [LAN-24, "CAN COMMUNICATION"](#).

A  
B  
C  
D  
E  
F  
G  
H  
I  
J  
L  
M

DI

# WARNING CHIME

EKS00FFT

## Wiring Diagram — CHIME —

### DI-CHIME-01

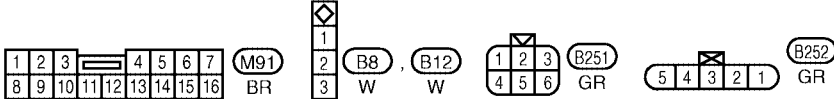
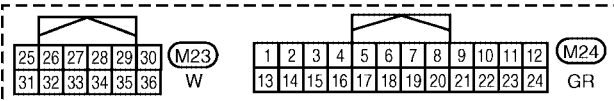
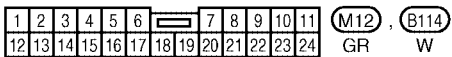
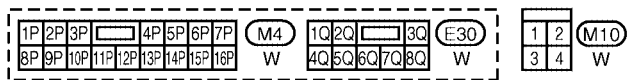
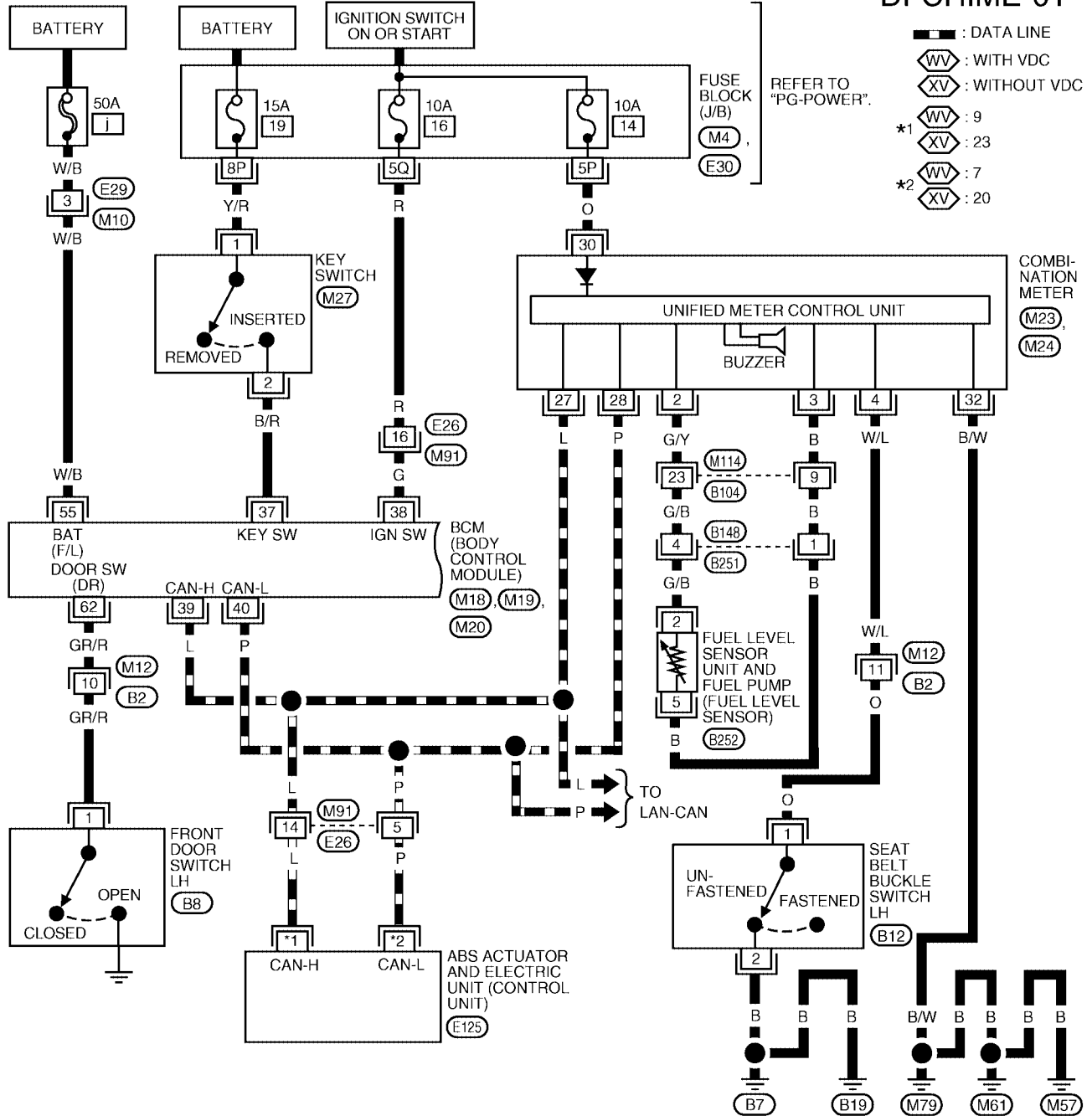

REFER TO THE FOLLOWING.  
**M18**, **M19**, **M20**, **E125**  
 - ELECTRICAL UNITS

WKWA3140E

# WARNING CHIME

DI-CHIME-02

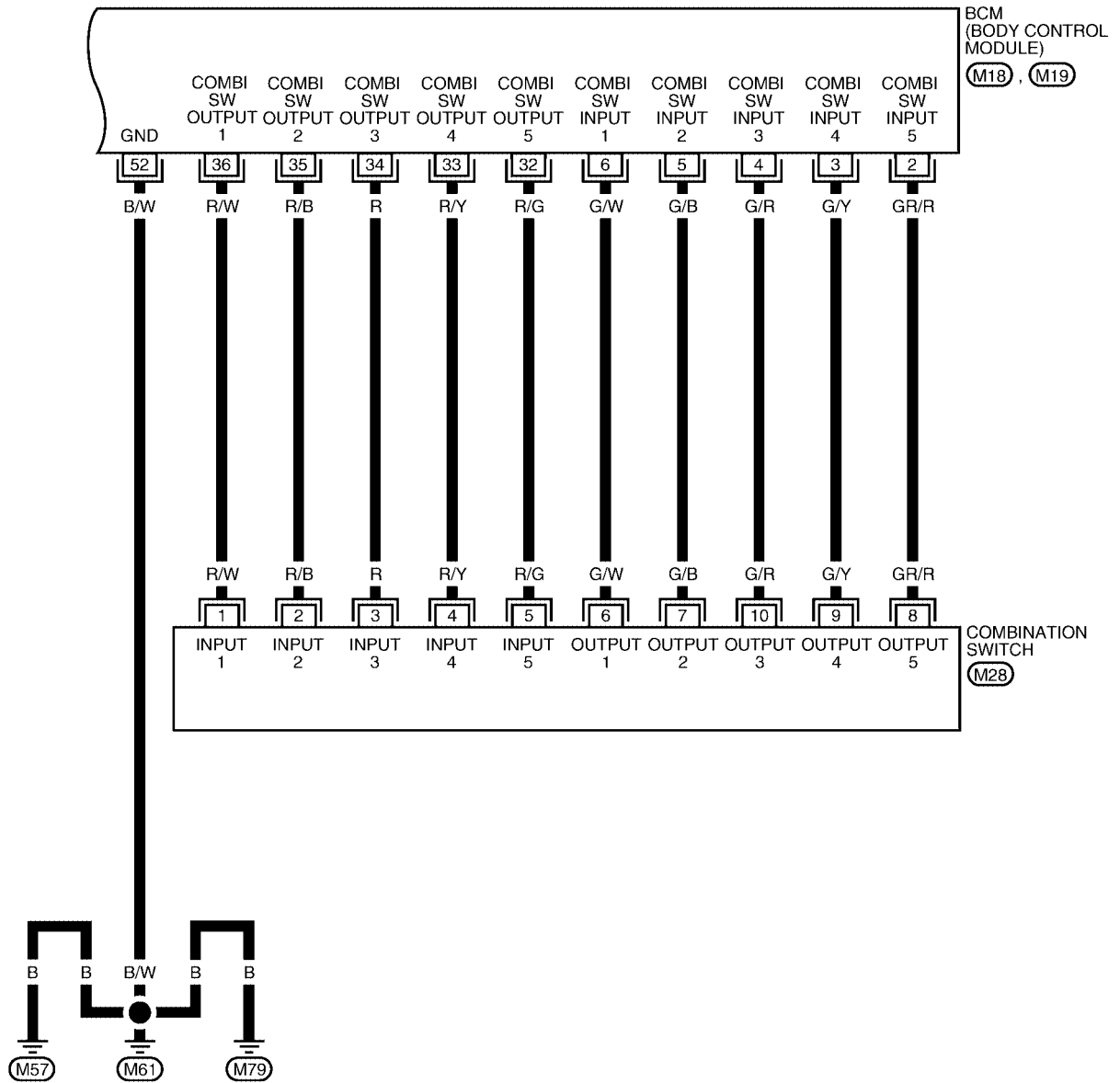

A  
B  
C  
D  
E  
F  
G  
H  
I  
J  
DI  
L  
M

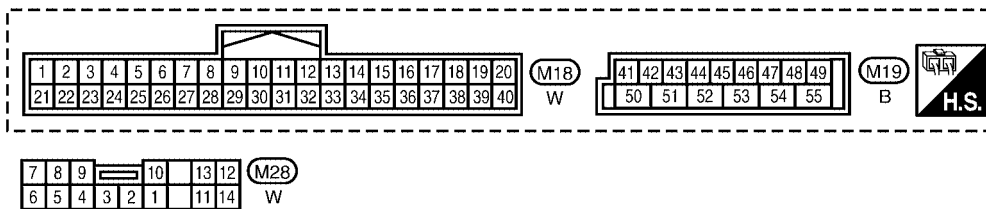



WKWA3141E

# WARNING CHIME

## Terminals and Reference Value for BCM

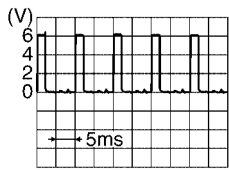
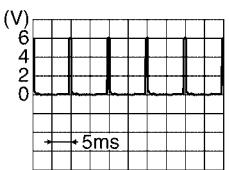
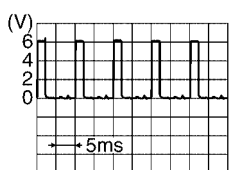
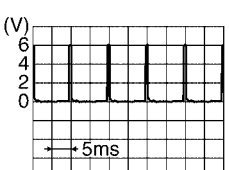
EKS00FFU

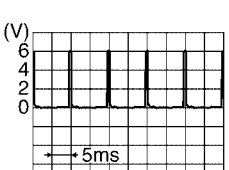
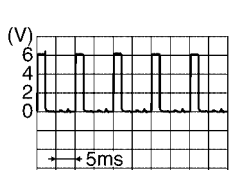
Terminal No.	Wire color	Item	Condition		Reference value (V) (Approx.)
			Ignition switch	Measurement method	
2	GR/R	Combination switch input 5	ON	<ul style="list-style-type: none"> <li>Light switch and wiper switch OFF</li> <li>Wiper dial position 4</li> </ul>	 <p style="text-align: right;">SKIA5291E</p>
3	G/Y	Combination switch input 4	ON	<ul style="list-style-type: none"> <li>Light switch and wiper switch OFF</li> <li>Wiper dial position 4</li> </ul>	 <p style="text-align: right;">SKIA5292E</p>
4	G/R	Combination switch input 3	ON	<ul style="list-style-type: none"> <li>Light switch and wiper switch OFF</li> <li>Wiper dial position 4</li> </ul>	 <p style="text-align: right;">SKIA5291E</p>
5	G/B	Combination switch input 2	ON	<ul style="list-style-type: none"> <li>Light switch and wiper switch OFF</li> <li>Wiper dial position 4</li> </ul>	 <p style="text-align: right;">SKIA5292E</p>
6	G/W	Combination switch input 1			
32	R/G	Combination switch output 5	ON	<ul style="list-style-type: none"> <li>Light switch and wiper switch OFF</li> <li>Wiper dial position 4</li> </ul>	 <p style="text-align: right;">SKIA5291E</p>
33	R/Y	Combination switch output 4	ON	<ul style="list-style-type: none"> <li>Light switch and wiper switch OFF</li> <li>Wiper dial position 4</li> </ul>	 <p style="text-align: right;">SKIA5292E</p>
34	R	Combination switch output 3	ON	<ul style="list-style-type: none"> <li>Light switch and wiper switch OFF</li> <li>Wiper dial position 4</li> </ul>	 <p style="text-align: right;">SKIA5291E</p>

# WARNING CHIME

Terminal No.	Wire color	Item	Condition		Reference value (V) (Approx.)
			Ignition switch	Measurement method	
35	R/B	Combination switch output 2	ON	<ul style="list-style-type: none"> <li>● Light switch and wiper switch OFF</li> <li>● Wiper dial position 4</li> </ul>	
36	R/W	Combination switch output 1			
37	B/R	Key switch signal	OFF	Key is removed	0
				Key is inserted	Battery voltage
38	G	Ignition switch ON or START	ON	—	Battery voltage
39	L	CAN-H	OFF	—	—
40	P	CAN-L	OFF	—	—
52	B/W	Ground	OFF	—	0
55	W/B	Battery power supply	OFF	—	Battery voltage
62	GR/R	Front door switch LH signal	OFF	ON (open)	0
				OFF (closed)	5

## Terminals and Reference Value for Combination Meter

EKS00FFV

Terminal No.	Wire color	Item	Condition		Reference value (V) (Approx.)
			Ignition switch	Measurement method	
2	G/Y	Fuel level sensor signal input	—	—	Refer to <a href="#">DI-17, "Fuel Level Sensor Unit Inspection"</a> .
3	B	Fuel level sensor signal output	—	—	Refer to <a href="#">DI-17, "Fuel Level Sensor Unit Inspection"</a> .
4	W/L	Seat belt buckle switch LH	ON	Unfastened (ON)	0
				Fastened (OFF)	Battery voltage
27	L	CAN-H	OFF	—	—
28	P	CAN-L	OFF	—	—
30	O	Ignition switch ON or START	ON	—	Battery voltage
32	B/W	Ground	OFF	—	0V

## How to Proceed With Trouble Diagnosis

EKS00FFW

1. Confirm the symptom or customer complaint.
2. Understand operation description and function description. Refer to [DI-34, "System Description"](#) .
3. Perform the preliminary check. Refer to [DI-40, "Preliminary Check"](#) .
4. Check symptom and repair or replace the cause of malfunction.
5. Does the warning chime operate properly? If so, go to 6. If not, go to 3.
6. Inspection End.

# WARNING CHIME

EKS00FFX

## Preliminary Check INSPECTION FOR POWER SUPPLY AND GROUND CIRCUIT

### 1. CHECK FUSES

Check for blown BCM fuses.

Unit	Power source	Fuse No.
BCM	Battery	j
	Ignition switch ON or START	16

Refer to [DI-36. "Wiring Diagram — CHIME —"](#).

OK or NG

OK >> GO TO 2.

NG >> If fuse is blown, be sure to eliminate cause of malfunction before installing new fuse. Refer to [PG-4. "POWER SUPPLY ROUTING CIRCUIT"](#).

### 2. CHECK POWER SUPPLY CIRCUIT

1. Disconnect BCM connectors M18 and M19.
2. Check voltage between BCM harness connector terminals and ground.

Terminals		(-)	Ignition switch position		
(+)			OFF	ACC	ON
Connector	Terminal				
M19	55	Ground	Battery voltage	Battery voltage	Battery voltage
M18	38		0V	0V	Battery voltage

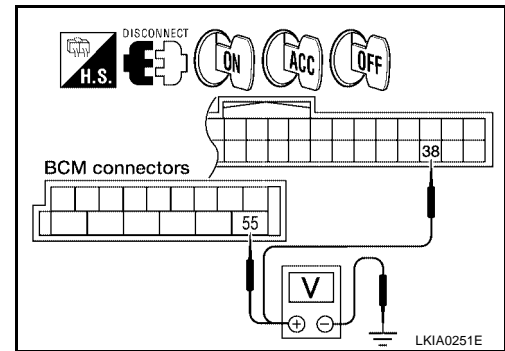

OK or NG

OK >> GO TO 3.

NG >> Check harness for open between BCM and fuse.

### 3. CHECK GROUND CIRCUIT

1. Turn ignition switch OFF.
2. Check continuity between BCM harness connector M19 terminal 52 and ground.

**Continuity should exist.**

OK or NG

OK >> Inspection End.

NG >> Repair harness or connector.

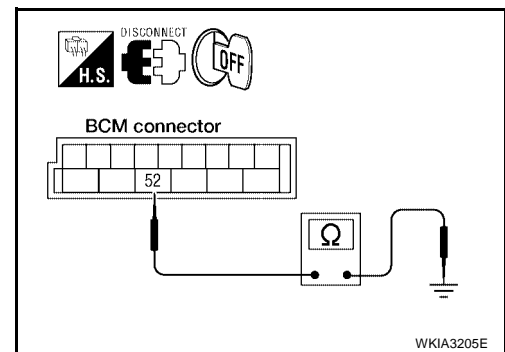



# WARNING CHIME

EKS00FFY

## CONSULT-II Function (BCM)

CONSULT-II can display each diagnostic item using the diagnostic test modes shown following.

BCM diagnostic test item	Diagnostic mode	Description
Inspection by part	WORK SUPPORT	Supports inspections and adjustments. Commands are transmitted to the BCM for setting the status suitable for required operation, input/output signals are received from the BCM and received data is displayed.
	DATA MONITOR	Displays BCM input/output data in real time.
	ACTIVE TEST	Operation of electrical loads can be checked by sending drive signal to them.
	SELF-DIAG RESULTS	Displays BCM self-diagnosis results.
	CAN DIAG SUPPORT MNTR	The result of transmit/receive diagnosis of CAN communication can be read.
	ECU PART NUMBER	BCM part number can be read.
	CONFIGURATION	Performs BCM configuration read/write functions.

### CONSULT-II BASIC OPERATION PROCEDURE

#### CAUTION:

If CONSULT-II is used with no connection of CONSULT-II CONVERTER, malfunctions might be detected in self-diagnosis depending on control unit which carries out CAN communication.

1. With the ignition switch OFF, connect CONSULT-II and CONSULT-II CONVERTER to the data link connector, and turn ignition switch ON.

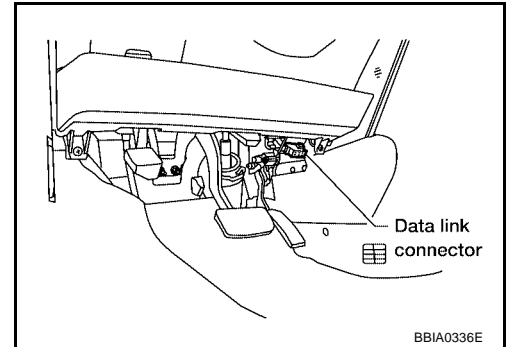

2. Touch "START (NISSAN BASED VHCL)".

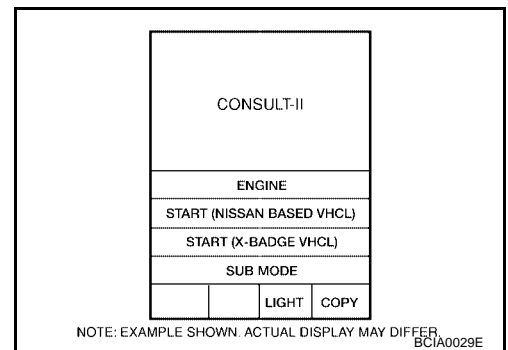

3. Touch "BCM" on "SELECT SYSTEM" screen. If "BCM" is not indicated, go to [GI-38, "CONSULT-II Data Link Connector \(DLC\) Circuit"](#).

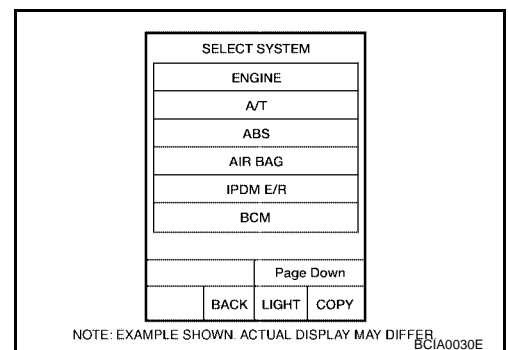

# WARNING CHIME

4. Touch "BUZZER" or "BCM".
5. Select "DATA MONITOR", "ACTIVE TEST" or "SELF-DIAG RESULTS".

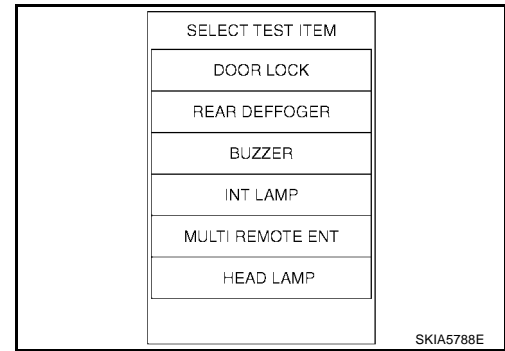

## DATA MONITOR

### Operation Procedure

1. Touch "BUZZER" on "SELECT TEST ITEM" screen.
2. Touch "DATA MONITOR" on "SELECT DIAG MODE" screen.
3. Touch "ALL SIGNALS" or "SELECTION FROM MENU" on "DATA MONITOR" screen.

ALL SIGNALS	Monitors main items.
SELECTION FROM MENU	Selects and monitors items.

4. Touch "START".
5. If "SELECTION FROM MENU" is selected, touch the item you desire to monitor. If "ALL SIGNALS" is selected, all control items are monitored.
6. During monitoring, touching "RECORD" can start recording the monitored item status.

### Data Monitor Item

Monitored item	Description
IGN ON SW	Indicates [ON/OFF] condition of ignition switch.
KEY ON SW	Indicates [ON/OFF] condition of key switch.
DOOR SW-DR	Indicates [ON/OFF] condition of front door switch (driver side).
LIGHT SW 1ST	Indicates [ON/OFF] condition of lighting switch.

## ACTIVE TEST

### Operation Procedure

1. Touch "BUZZER" on "SELECT TEST ITEM" screen.
2. Touch "ACTIVE TEST" on "SELECT DIAG MODE" screen.
3. Touch the item to be tested, and check the operation.
4. During the operation check, touching "OFF" deactivates the operation.

### Active Test Item

Test item	Malfunction is detected when--
LIGHT WARN ALM	This test is able to check light warning chime operation. Light warning chime sounds for 2 seconds after touching "ON" on CONSULT-II screen.
IGN KEY WARN ALM	This test is able to check key warning chime operation. Key warning chime sounds for 2 seconds after touching "ON" on CONSULT-II screen.
SEAT BELT WARN TEST	This test is able to check seat belt warning chime operation. Seat belt warning chime sounds for 2 seconds after touching "ON" on CONSULT-II screen.

## SELF-DIAGNOSTIC RESULTS

### Operation Procedure

1. Touch "BCM" on "SELECT TEST ITEM" screen.
2. Touch "SELF-DIAG RESULTS" on "SELECT DIAG MODE" screen.
3. Self-diagnostic results are displayed.

# WARNING CHIME

## Display Item List

Monitored Item	CONSULT-II display	Description
CAN communication	CAN communication [U1000]	Malfunction is detected in CAN communication.

**NOTE:**

If "CAN communication U1000" is indicated, after printing the monitor item, go to "CAN System". Refer to [LAN-24, "CAN COMMUNICATION"](#).

## All Warning Chimes Do Not Operate

EKS00FFZ

### 1. CHECK BCM CHIME OPERATION

Select "BUZZER" on CONSULT-II, and perform "LIGHT WARN ALM", "IGN KEY WARN ALM", OR "SEAT BELT WARN TEST" active test.

Does chime sound?

- YES >> Replace the BCM. Refer to [BCS-20, "Removal and Installation of BCM"](#).
- NO >> Replace the combination meter. Refer to [DI-20, "Combination Meter"](#).

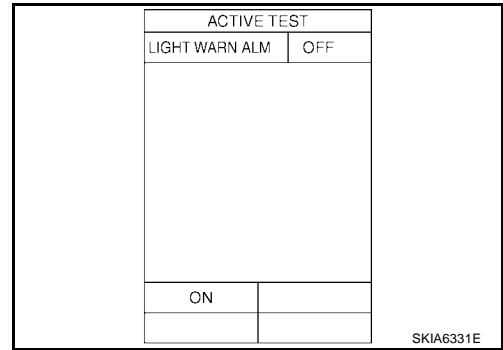

## Key Warning Chime and Light Warning Chime Do Not Operate (Seat Belt Warning Chime Does Operate)

EKS00FG0

### 1. CHECK BCM INPUT SIGNAL

**With CONSULT-II**

- Select "BCM" on CONSULT-II.
- With "DATA MONITOR" of "BUZZER", confirm "DOOR SW-DR" changes with the status of front door LH.

- When front door LH is opened : DOOR SW-DR ON**
- When front door LH is closed : DOOR SW-DR OFF**

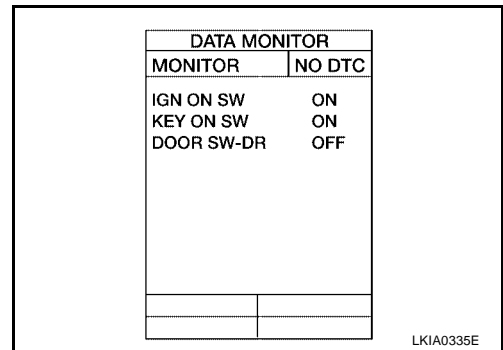

**Without CONSULT-II**

Check voltage between BCM harness connector M20 terminal 62 and ground.

- When front door LH is opened : Approx. 0V**
- When front door LH is closed : Approx. 5V**

OK or NG

- OK >> Replace the BCM. Refer to [BCS-20, "Removal and Installation of BCM"](#).
- NG >> GO TO 2.

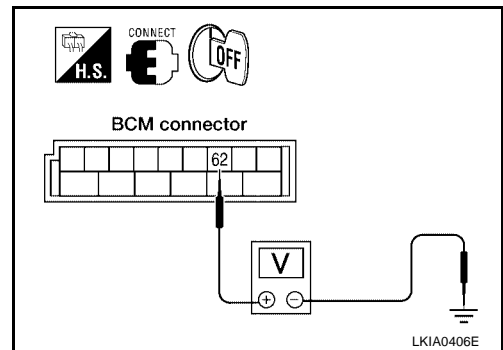

# WARNING CHIME

## 2. CHECK FRONT DOOR SWITCH LH CIRCUIT

1. Turn ignition switch OFF.
2. Disconnect BCM connector M20 and front door switch LH connector B8.
3. Check continuity between BCM harness connector M20 terminal 62 and front door switch LH harness connector B8 terminal 1.

**Continuity should exist.**

4. Check continuity between BCM harness connector M20 terminal 62 and ground.

**Continuity should not exist.**

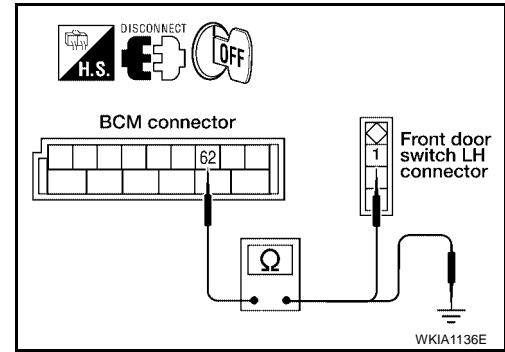

OK or NG

OK >> GO TO 3.

NG >> Repair harness or connector.

## 3. CHECK FRONT DOOR SWITCH LH

Check continuity between front door switch LH terminal 1 and exposed metal of switch while pushing and releasing switch.

**When front door LH switch is released : Continuity should exist.**

**When front door LH switch is pushed : Continuity should not exist.**

OK or NG

OK >> Replace the BCM. Refer to [BCS-20, "Removal and Installation of BCM"](#).

NG >> Replace the front door switch LH.

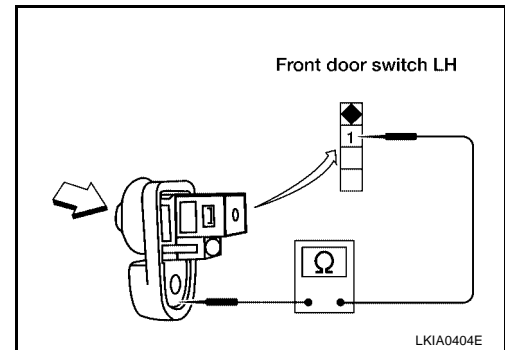

EKS00FG1

## Key Warning Chime Does Not Operate

### 1. CHECK FUSE

Check if the key switch 10A fuse [No. 19, located in the fuse block (J/B)] is blown. Refer to [DI-36, "Wiring Diagram — CHIME —"](#).

Is the fuse blown?

YES >> Replace the fuse. Be sure to repair the cause of malfunction before installing new fuse.

NO >> GO TO 2.

### 2. CHECK WARNING CHIME OPERATION

With key removed from the ignition and the front door LH open, turn the lighting switch to 1st or 2nd position.

Does warning chime sound?

YES >> GO TO 3.

NO >> Go to [DI-43, "All Warning Chimes Do Not Operate"](#) or [DI-43, "Key Warning Chime and Light Warning Chime Do Not Operate \(Seat Belt Warning Chime Does Operate\)"](#).

# WARNING CHIME

## 3. CHECK BCM INPUT SIGNAL

### With CONSULT-II

With "DATA MONITOR" of "BUZZER", confirm "KEY ON SW" changes when the key is inserted/removed from the ignition key cylinder.

**When key is inserted in ignition : KEY ON SW ON  
key cylinder**

**When key is removed from : KEY ON SW OFF  
ignition key cylinder**

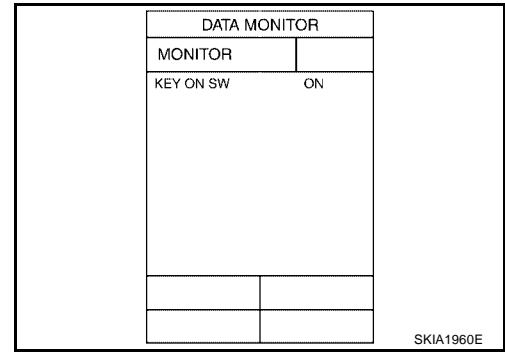

### Without CONSULT-II

Check voltage between BCM harness connector M18 terminal 37 and ground.

Terminals		(-)	Condition	Voltage (V)
(+)				
Connector	Terminal			
M18	37	Ground	Key is inserted	Battery voltage
			Key is removed	0

OK or NG

OK >> Replace the BCM. Refer to [BCS-20, "Removal and Installation of BCM"](#).

NG >> GO TO 4.

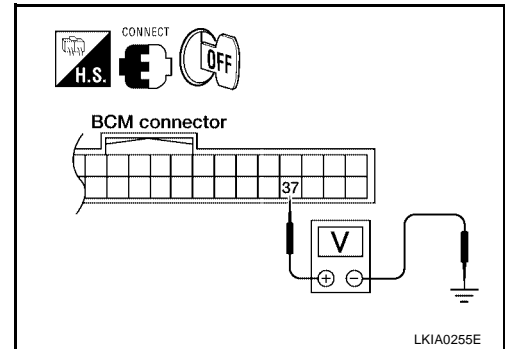

## 4. CHECK KEY SWITCH

1. Disconnect key switch connector.
2. Check continuity between key switch terminals 1 and 2.

Terminals		Condition	Continuity
1	2		
		Key is inserted	Yes
		Key is removed	No

OK or NG

OK >> GO TO 5.

NG >> Replace the key switch.

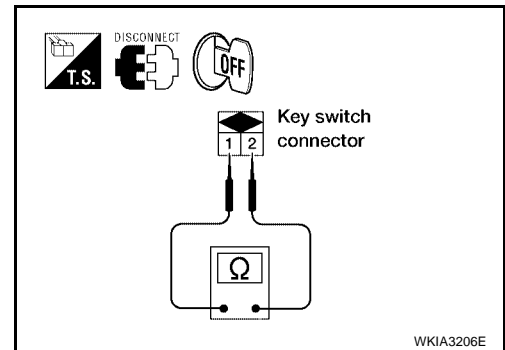

## 5. CHECK KEY SWITCH CIRCUIT

1. Disconnect BCM connector M18.
2. Check continuity between BCM harness connector M18 terminal 37 and key switch harness connector M27 terminal 2.

**Continuity should exist.**

3. Check continuity between BCM harness connector M18 terminal 37 and ground.

**Continuity should not exist.**

OK or NG

OK >> GO TO 6.

NG >> Repair harness or connector.

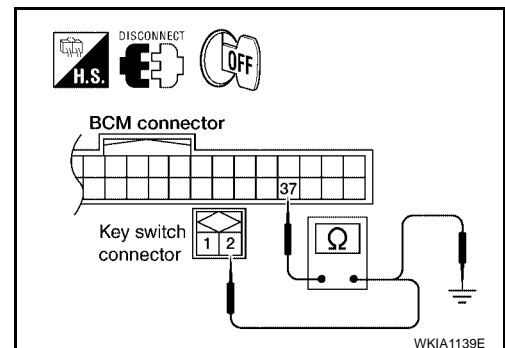

# WARNING CHIME

## 6. CHECK KEY SWITCH POWER SUPPLY CIRCUIT

Check voltage between key switch harness connector M27 terminal 1 and ground.

**Battery voltage should exist.**

OK or NG

- OK >> Replace the BCM. Refer to [BCS-20, "Removal and Installation of BCM"](#) .
- NG >> Check harness for open between key switch and fuse.

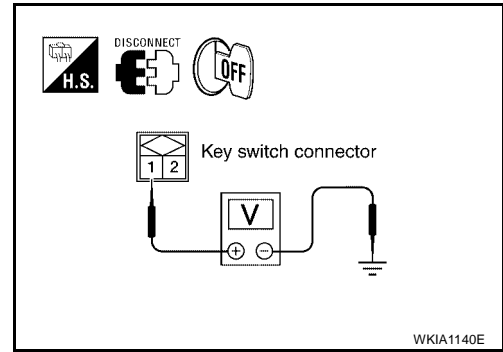

## Light Warning Chime Does Not Operate

EKS00FG2

### 1. CHECK WARNING CHIME OPERATION

Check key warning chime and seat belt warning chime functions.

Do key warning chime and seat belt warning chime sound?

- YES >> GO TO 2.
- NO >> Go to [DI-43, "All Warning Chimes Do Not Operate"](#) .

### 2. CHECK BCM INPUT SIGNAL

Ⓟ With CONSULT-II

- Select "BCM".
- With "DATA MONITOR" of "BUZZER", confirm "LIGHT SW 1ST" status changes when the lighting switch is moved from ON (1st position) to OFF.

**Lighting switch ON (1st position) : LIGHT SW 1ST ON**  
**Lighting switch OFF : LIGHT SW 1ST OFF**

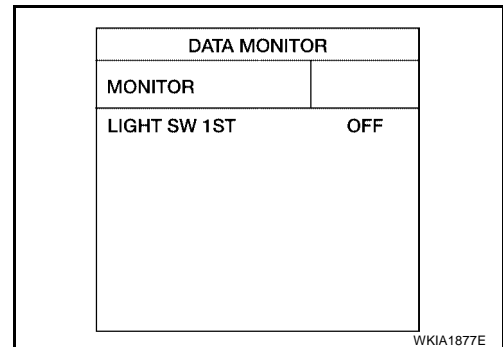

ⓧ Without CONSULT-II

Check combination switch. Refer to [LT-105, "Combination Switch Reading Function"](#) .

OK or NG

- OK >> Replace the BCM. Refer to [BCS-20, "Removal and Installation of BCM"](#) .
- NG >> Check lighting switch. Refer to [LT-105, "Combination Switch Reading Function"](#) .

## Seat Belt Warning Chime Does Not Operate

EKS00FG3

### 1. CHECK WARNING CHIME OPERATION

- With key removed from the ignition and the front door LH open, turn the lighting switch to 1st or 2nd position.
- Return lighting switch to OFF position, and insert key into ignition.

Does warning chime sound for both steps?

- YES >> GO TO 2.
- NO >> Go to [DI-43, "All Warning Chimes Do Not Operate"](#) .

# WARNING CHIME

## 2. CHECK SEAT BELT WARNING LAMP OPERATION

Turn ignition switch ON. Buckle and unbuckle driver seat belt while watching seat belt warning lamp.

**NOTE:**

While performing this test, the front passenger seat must be unoccupied.

**When seat belt is fastened : Warning lamp OFF**

**When seat belt is unfastened : Warning lamp ON**

OK or NG

OK >> Replace the BCM. Refer to [BCS-20, "Removal and Installation of BCM"](#) .

NG >> GO TO 3.

## 3. CHECK COMBINATION METER INPUT SIGNAL

Check voltage between combination meter harness connector M24 terminal 4 and ground.

Terminals		(-)	Condition	Voltage (V) (Approx.)
(+)				
Connector	Terminal			
M24	4	Ground	Seat belt is fastened	Battery voltage
			Seat belt is unfastened	0

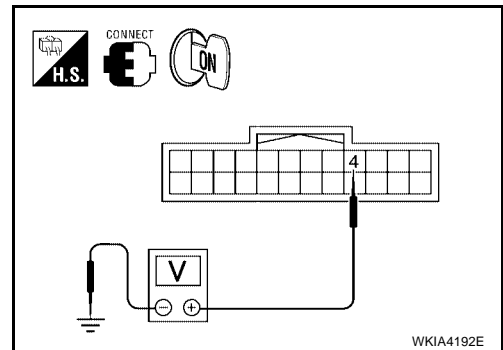

OK or NG

OK >> Replace the combination meter. Refer to [IP-12, "COMBINATION METER"](#) .

NG >> GO TO 4.

## 4. CHECK SEAT BELT BUCKLE SWITCH

1. Turn ignition switch OFF.
2. Disconnect seat belt buckle switch LH connector.
3. Check continuity between seat belt buckle switch LH terminals 1 and 2.

Terminals		Condition	Continuity
1	2		
1	2	Seat belt is fastened	No
		Seat belt is unfastened	Yes

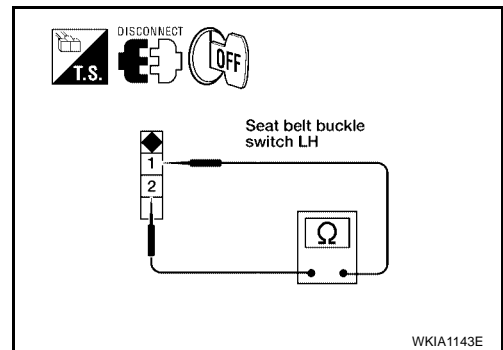

OK or NG

OK >> GO TO 5.

NG >> Replace the seat belt buckle switch LH.

# WARNING CHIME

## 5. CHECK SEAT BELT BUCKLE SWITCH CIRCUIT

1. Disconnect combination meter connector M24.
2. Check continuity between combination meter harness connector M24 terminal 4 and seat belt buckle switch LH harness connector B12 terminal 1.

**Continuity should exist.**

3. Check continuity between combination meter harness connector M24 terminal 4 and ground.

**Continuity should not exist.**

OK or NG

- OK >> Check seat belt buckle switch ground circuit.  
NG >> Repair harness or connector.

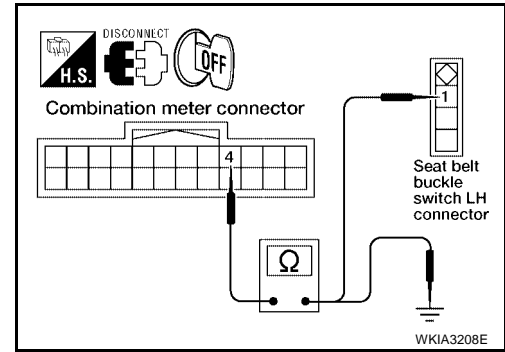



# REAR SONAR SYSTEM

PFP:28532

EKS00FG4

## REAR SONAR SYSTEM

### Component Parts and Harness Connector Location

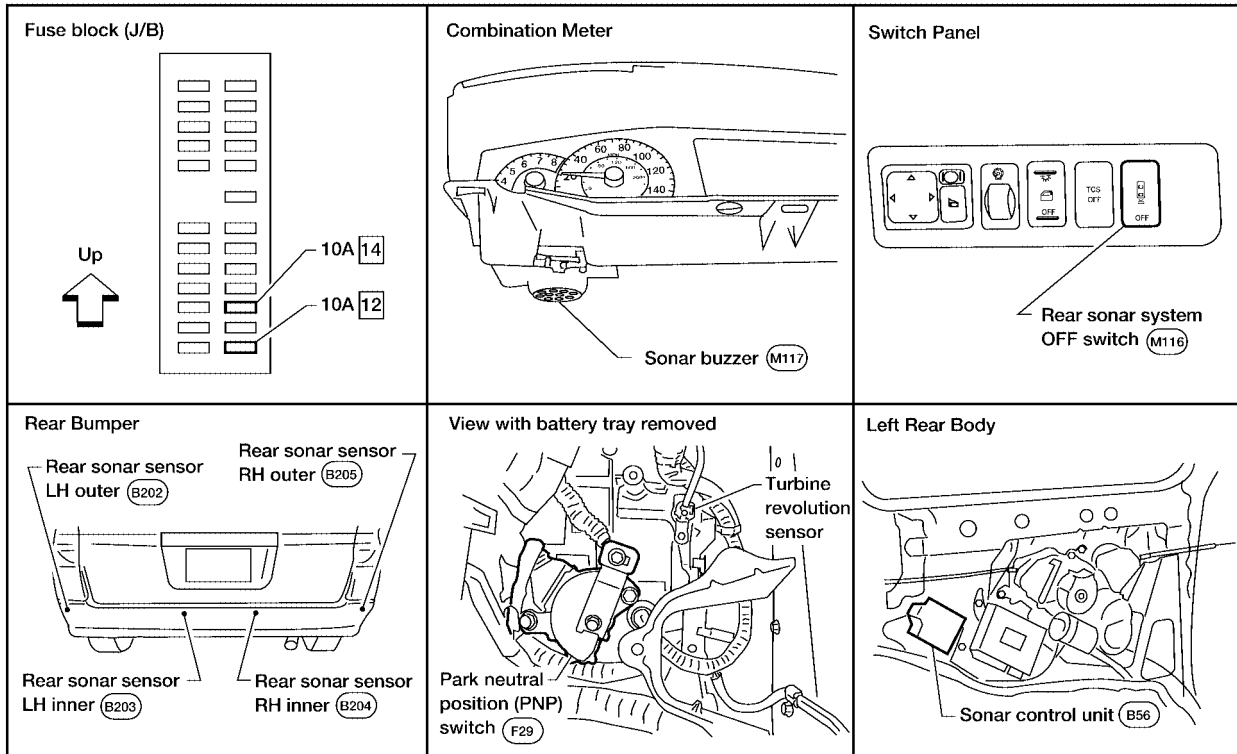

WKIA4193E

EKS00FG5

## System Description

### FUNCTION

With the ignition switch in the ON or START position, power is supplied

- through 10A fuse [No. 12, located in the fuse block (J/B)]
- to sonar control unit terminal 8, and
- through 10A fuse [No. 14, located in the fuse block (J/B)]
- to park/neutral position (PNP) switch terminal 3 (4-speed A/T) or 2 (5-speed A/T).

Ground is supplied

- to sonar control unit terminal 6
- through body grounds B7 and B19.

With the ignition switch in the ON or START position, and the selector lever in the R position, power is supplied

- to sonar control unit terminal 5
- from park/neutral position (PNP) switch terminal 8 (4-speed A/T) or 4 (5-speed A/T).

With power and ground supplied, selector lever in R position, and the rear sonar system OFF switch ON, the rear sonar system will detect obstacles within 1.8 m (5.9 ft) of the rear sonar sensors. The vehicle operator is notified of obstacles by varied lengths of tone from the sonar buzzer depending on distance of obstacle being sensed.

### REAR SONAR SYSTEM OFF SWITCH

With power and ground supplied to the sonar control unit, selector lever in R position, the sonar system can be disabled and the sonar buzzer silenced by momentarily pressing the rear sonar system OFF switch. The rear sonar system OFF indicator lamp will be illuminated in the rear sonar system OFF switch.

To disable the rear sonar system, ground is supplied

- to sonar control unit terminal 13
- through rear sonar system OFF switch terminal 7

A  
B  
C  
D  
E  
F  
G  
H  
I  
J

DI

L

M

## REAR SONAR SYSTEM

---

- through rear sonar system OFF switch terminal 6
- from body grounds M57, M61, and M79.

To light the rear sonar system OFF indicator, power is supplied

- to the rear sonar system OFF switch terminal 3
- from sonar control unit terminal 4.

Ground is supplied

- to the rear sonar system OFF switch terminal 2
- from body grounds M57, M61, and M79.

The rear sonar system and buzzer will be disabled and the rear sonar system OFF indicator will be illuminated until the ignition switch is turned OFF. When the ignition is turned ON, the rear sonar system will be enabled. Depressing the rear sonar system OFF switch momentarily will enable the rear sonar system also. Enabling the rear sonar system will cause the rear sonar system OFF indicator to go out.

### SONAR BUZZER

With the power supplied to the sonar control unit, selector lever in R position and a stationary object at least 7.0 cm (2.8 in.) wide and 10.0 cm (3.9 in.) tall closer than 1.8 meters (5.9 ft.) will be detected by the rear sonar sensors, the sonar buzzer will sound a tone. As the vehicle approaches the object, the rate of the tone will increase. When the object is less than 25.0 cm (10 in.) from the rear bumper, the tone will sound continuously. Power is supplied

- to sonar buzzer terminal +
- from sonar control unit terminal 7.

Ground is supplied

- to sonar buzzer terminal -
- from sonar control unit terminal 3.

### REAR SONAR SENSOR

With power and ground supplied to the rear sonar sensors, the sonar sensors transmit a 38.4 kHz ultrasonic signal. This signal is reflected back to the sensor by objects large enough and close enough to be detected. The rear sonar sensors measure the time from the transmitted signal to the time the signal is reflected back and sends this information to the sonar control unit.

Power is supplied

- to rear sonar sensors terminal 1
- from sonar control unit terminal 16.

Ground is supplied

- to rear sonar sensors terminal 3
- from sonar control unit terminal 15.

Signal is supplied

- to sonar control unit terminals 9, 10, 11 and 12
- from rear sonar sensors terminal 2.

# REAR SONAR SYSTEM

## Wiring Diagram — SONAR —

EKS00FG6

### DI-SONAR-01

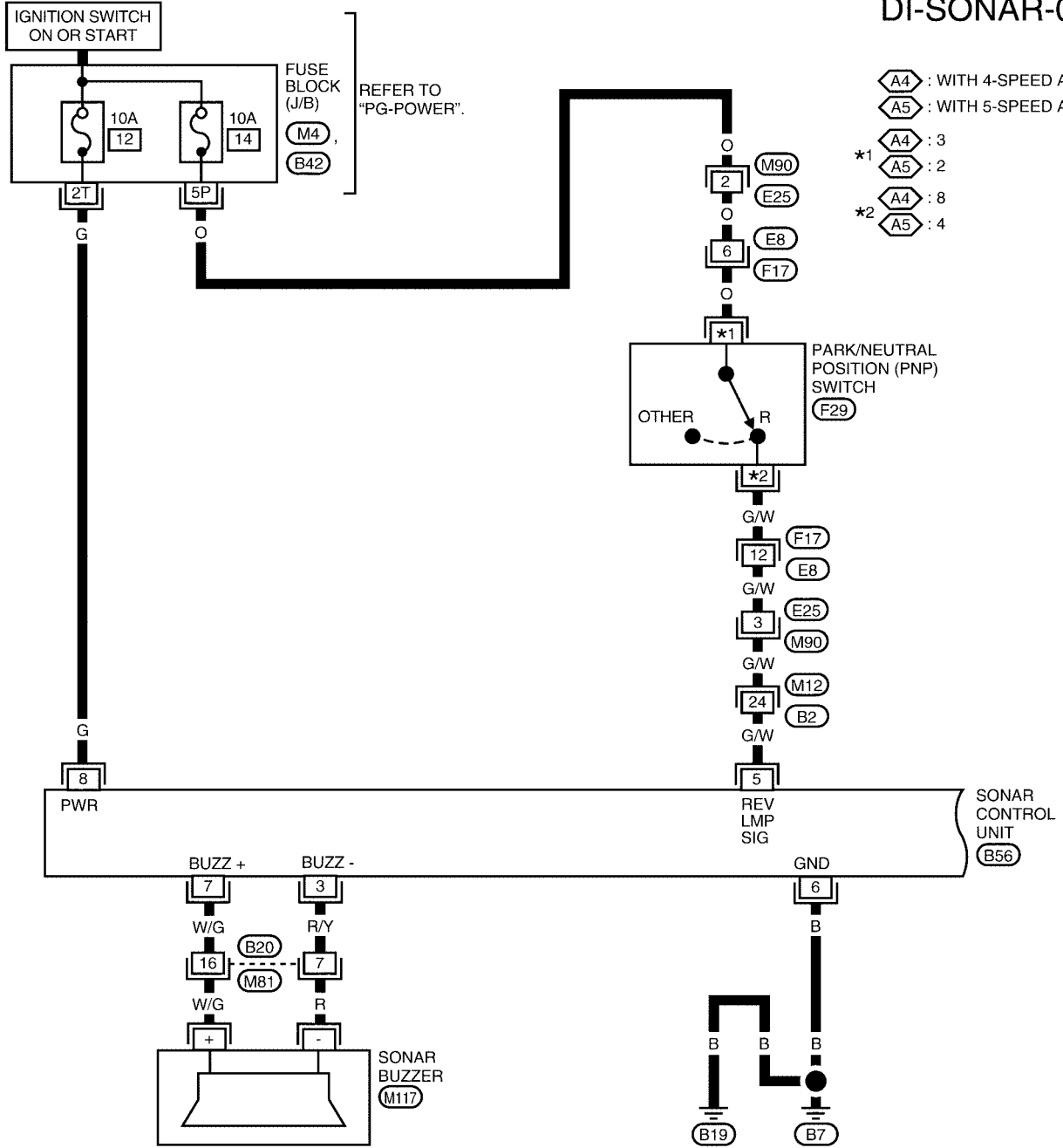

- A4 : WITH 4-SPEED A/T
- A5 : WITH 5-SPEED A/T
- \*1 A4 : 3, A5 : 2
- \*2 A4 : 8, A5 : 4

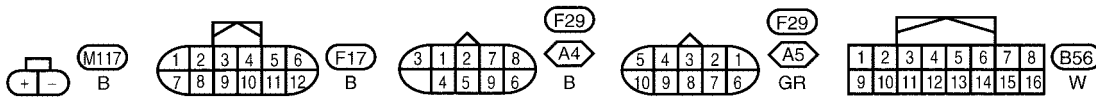
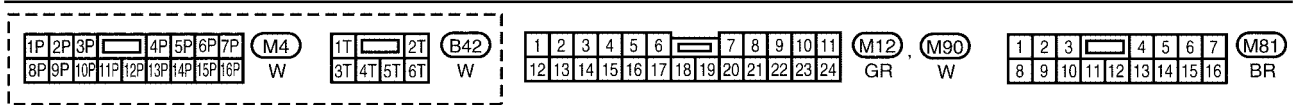

# REAR SONAR SYSTEM

DI-SONAR-02

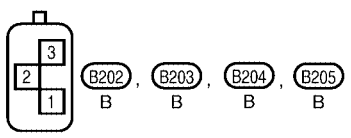
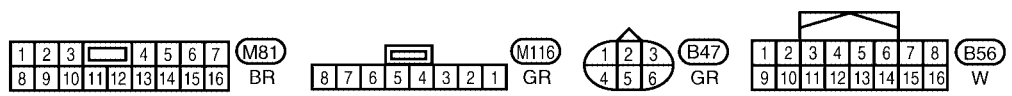
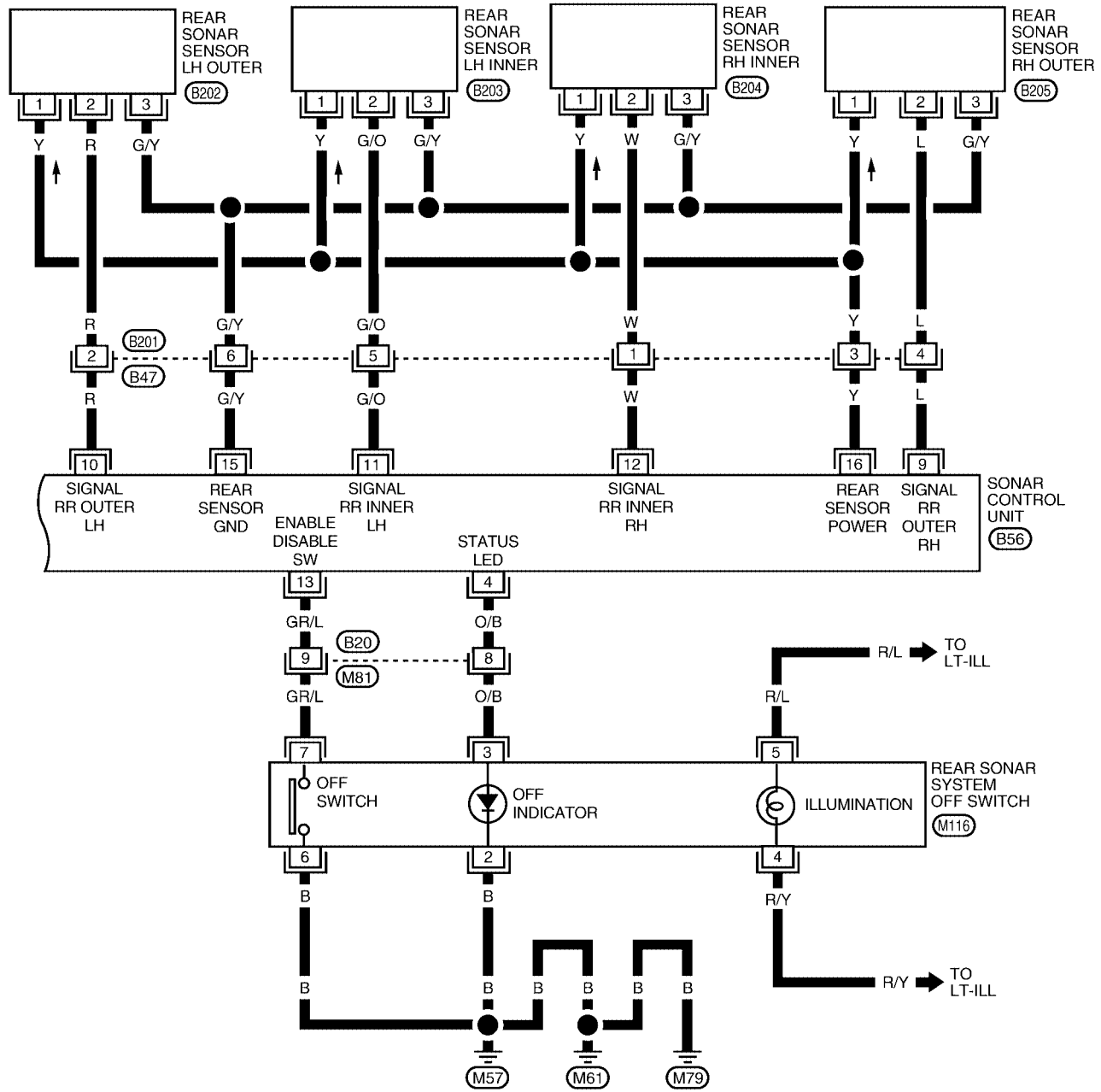

WKWA3143E

# REAR SONAR SYSTEM

## Terminals And Reference Value For Sonar Control Unit

EKS00FG7

Terminal (Wire color)	Item	Condition		Reference value (V) (Approx.)	
		Ignition switch	Operation		
3 (R/Y)	Sonar buzzer return	ON	—	0	
4 (O/B)	Rear sonar system OFF indicator output	ON	Rear sonar system OFF switch	ON	0
				OFF	Battery voltage
5 (G/W)	Reverse signal	ON	Selector lever	R position	Battery voltage
			Selector lever	Not R position	0
6 (B)	Sonar control unit ground	OFF	—	0	
7 (W/G)	Sonar buzzer drive signal	ON	<ul style="list-style-type: none"> <li>● Rear sonar system OFF switch ON</li> <li>● Selector lever in R position</li> <li>● No obstacles</li> </ul>		Battery voltage
			<ul style="list-style-type: none"> <li>● Rear sonar system OFF switch ON</li> <li>● Selector lever in R position</li> <li>● Distance between rear sonar sensor and obstacle is &lt;0.25 m (0.82 ft) or less.</li> </ul>		0
			<ul style="list-style-type: none"> <li>● Rear sonar system OFF switch ON</li> <li>● Selector lever in R position</li> <li>● Distance between rear sonar sensor and obstacle is 0.25 to 1.8 m (0.82 to 5.9 ft).</li> </ul>		Cycles between 0.001 and 12
8 (G)	Sonar control unit power	ON	—	Battery voltage	
9 (L)	Rear sonar sensor signal - RH outer	ON	<ul style="list-style-type: none"> <li>● Rear sonar system OFF switch ON</li> <li>● Selector lever in R position</li> <li>● No obstacles</li> </ul>	Battery voltage	
10 (R)	Rear sonar sensor signal - LH outer	ON	<ul style="list-style-type: none"> <li>● Rear sonar system OFF switch ON</li> <li>● Selector lever in R position</li> <li>● No obstacles</li> </ul>	Battery voltage	
11 (G/O)	Rear sonar sensor signal - LH inner	ON	<ul style="list-style-type: none"> <li>● Rear sonar system OFF switch ON</li> <li>● Selector lever in R position</li> <li>● Distance obstacles</li> </ul>	Battery voltage	
12 (W)	Rear sonar sensor signal - RH inner	ON	<ul style="list-style-type: none"> <li>● Rear sonar system OFF switch ON</li> <li>● Selector lever in R position</li> <li>● Distance obstacles</li> </ul>	Battery voltage	
13 (GR/L)	Rear sonar system OFF switch signal	ON	Rear sonar system OFF switch	ON	0
				OFF	9
15 (G/Y)	Rear sonar sensor ground	ON	—	0	
16 (Y)	Rear sonar sensor power	ON	Ignition switch ON	Battery voltage	

### How to Proceed With Trouble Diagnosis

EKS00FG8

1. Confirm the symptom or customer complaint.
2. Understand operation description and function description. Refer to [DI-49, "System Description"](#) .
3. Perform pre-diagnosis inspection. Refer to [DI-54, "Pre-diagnosis Inspection"](#) .
4. Perform self-diagnosis. Refer to [DI-54, "Self-diagnosis Function"](#) .
5. Perform the preliminary check. Refer to [DI-56, "Preliminary Check"](#) .
6. Check symptom and repair or replace the cause of malfunction. Refer to [DI-57, "Symptom Chart"](#) .

# REAR SONAR SYSTEM

7. Does the rear sonar system operate properly? If so, go to 8. If not, go to 3.
8. Inspection End.

## Pre-diagnosis Inspection SENSOR STATUS CHECK

EKS00FG9

- Check that the rear sonar sensor is not frozen.
- Check that snow, mud, or other foreign objects are not adhering to the rear sonar sensor.
- Check that there is no deformation, scratches, or other damage to the rear sonar sensor.
- Check that water has not accumulated in the rear sonar sensor.

### CAUTION:

Use water, cotton swab, or other soft material for cleaning the sensor.

1. Check that there are no obstacles within each rear sonar sensor's detection range.

	Detection range
Rear sonar sensors	Approx. 1.8 m (5.9 ft) maximum

2. Check that there are no nearby ultrasound sources (such as the sounds of vehicle horns, motorcycle engines, or truck air brakes).
3. Check that the vehicle is on a level surface.

## Self-diagnosis Function

EKS00FGA

There are four modes of self-diagnosis; entering diagnostics, requesting number of fault codes, requesting fault codes, and idling or clearing fault codes. These steps must be followed in order. Self-diagnosis can be manually exited by turning the ignition OFF, or selecting reverse gear. Self-diagnosis will automatically exit if a message is repeated five times without acknowledgement, before reporting number of faults if no switch activity is detected for thirty seconds or in idle mode if no switch activity is detected for thirty seconds.

### ENTERING DIAGNOSTICS MODE

1. Turn ignition switch ON. Rear sonar system OFF switch indicator lamp comes on for three seconds and then goes out.
2. Immediately push rear sonar system OFF switch ten times within five seconds.
3. The the sonar buzzer sounds once and the rear sonar system OFF indicator flashes once.

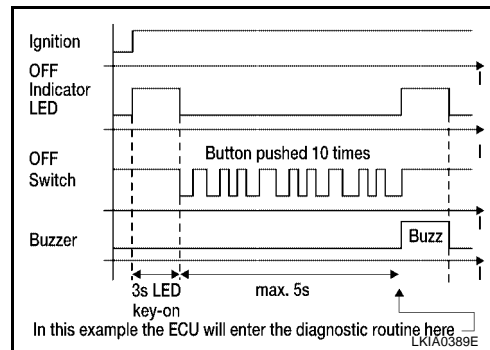

### REQUESTING NUMBER OF FAULT CODES MODE

1. While in diagnostic mode, push rear sonar system OFF switch once.
2. The sonar buzzer will sound once.
3. Rear sonar system OFF indicator will flash once and sonar buzzer will sound once for each fault code detected.
4. There will be a four second pause.
5. The number of fault codes will repeat then pause five times.

#### NOTE:

Self-diagnosis will exit unless requesting fault codes occurs before five repeats ends.

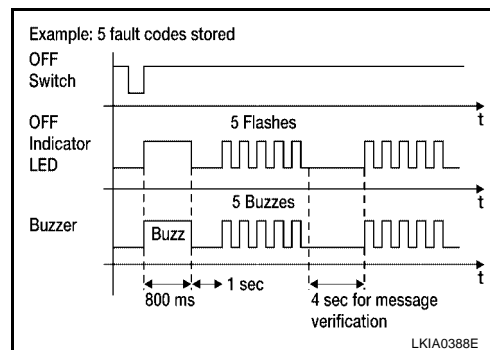

# REAR SONAR SYSTEM

## REQUESTING FAULT CODES MODE

1. While in requesting number of fault codes mode, push rear sonar system OFF switch once.
2. The sonar buzzer will sound once.
3. Rear sonar system OFF indicator will flash and sonar buzzer will sound the first digit of the fault code followed by a one second pause.
4. Rear sonar system OFF indicator will flash and sonar buzzer will sound the second digit of the fault code followed by a four second pause.
5. The fault codes will repeat then pause five times.

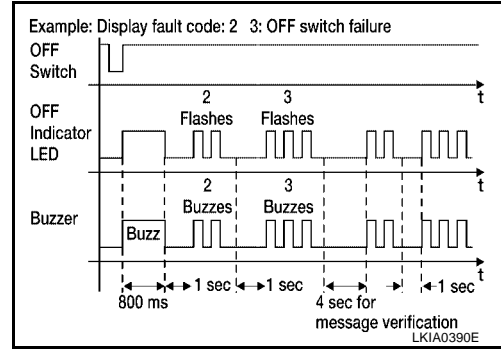

### NOTE:

Requesting fault codes will exit unless the fault code is acknowledged before five repeats ends.

The fault code is acknowledged by pushing the rear sonar system OFF switch once (the sonar buzzer may sound). When all fault codes have been indicated, idle mode will be entered. See the following table for fault code identification.

Fault Code	Malfunction	Page Reference
1 1	Rear sonar sensor LH outer	Check harness for open or short. If NG repair or replace harness. If OK replace sensor. Refer to <a href="#">EI-16, "Removal and Installation"</a> .
1 2	Rear sonar sensor LH inner	
1 3	Rear sonar sensor RH inner	
1 4	Rear sonar sensor RH outer	
2 1	Sonar buzzer	<a href="#">DI-58, "SONAR BUZZER"</a>
2 2	Rear sonar system OFF indicator	<a href="#">DI-58, "REAR SONAR SYSTEM OFF INDICATOR"</a>
2 3	Rear sonar system OFF switch	<a href="#">DI-58, "REAR SONAR SYSTEM OFF SWITCH"</a>
2 4	Sonar control unit	Replace sonar control unit. Refer to <a href="#">DI-58, "Sonar Control Unit"</a>

## IDLING OR CLEARING FAULT CODES MODE

### NOTE:

While in idle mode, self-diagnosis will automatically exit if no activity occurs for thirty seconds.

1. Push and hold rear sonar system OFF switch for three seconds to reset time-out counter.
2. Push and hold rear sonar system OFF switch for three seconds to clear codes.

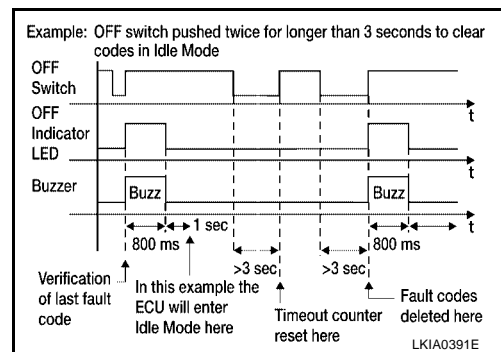

# REAR SONAR SYSTEM

EKS00FGB

## Preliminary Check INSPECTION FOR POWER SUPPLY AND GROUND CIRCUIT

### 1. CHECK FUSES

Check for blown rear sonar system fuses.

UNIT	POWER SOURCE	FUSE
Sonar control unit	ON or START	12

Refer to [DI-51, "Wiring Diagram — SONAR —"](#) .

OK or NG

OK >> GO TO 2.

NG >> If fuse is blown, be sure to eliminate cause of problem before installing new fuse. Refer to [PG-4, "POWER SUPPLY ROUTING CIRCUIT"](#) .

### 2. CHECK POWER SUPPLY CIRCUIT

1. Disconnect sonar control unit connector.
2. Check voltage between sonar control unit connector B56 terminal 8 and ground.

Terminals		Ignition switch position	
(+)		(-)	
Connector	Terminal	ON or START	
B56	8	Ground	Battery voltage

OK or NG

OK >> GO TO 3.

NG >> Check harness for open between sonar control unit and fuse.

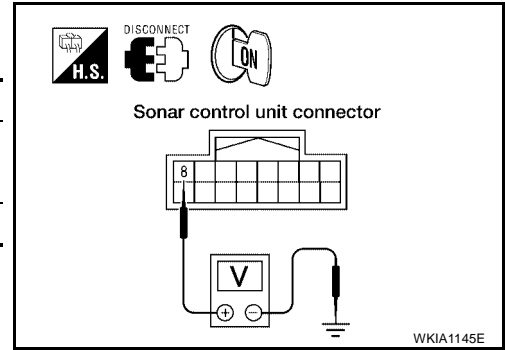

### 3. CHECK GROUND CIRCUIT

1. Turn ignition switch OFF.
2. Check continuity between sonar control unit connector B56 terminal 6 and ground.

Terminals		(-)	Continuity
(+)			
Connector	Terminal		
B56	6	Ground	Yes

OK or NG

OK >> Inspection End.

NG >> Repair harness or connector.

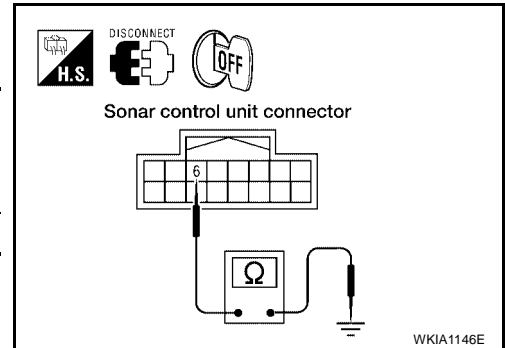



# REAR SONAR SYSTEM

## Symptom Chart

EKS00FGC

Symptom	Repair order
When the rear sonar system OFF switch is OFF, the indicator lamp does not light and the buzzer does not sound.	<ol style="list-style-type: none"> <li>1. Check rear sonar system OFF switch for malfunction. Refer to <a href="#">DI-58, "REAR SONAR SYSTEM OFF SWITCH"</a> .</li> <li>2. Check rear sonar system OFF switch ground circuit.</li> <li>3. Check harness and connections between rear sonar system OFF switch and sonar control unit.</li> <li>4. Replace sonar control unit. Refer to <a href="#">DI-58, "Sonar Control Unit"</a> .</li> </ol>
When the rear sonar system OFF switch is OFF, the indicator lamp does not light but buzzer sounds.	<ol style="list-style-type: none"> <li>1. Check rear sonar system OFF indicator for malfunction. Refer to <a href="#">DI-58, "REAR SONAR SYSTEM OFF INDICATOR"</a> .</li> <li>2. Check harness and connections between rear sonar system OFF indicator and sonar control unit.</li> <li>3. Replace sonar control unit. Refer to <a href="#">DI-58, "Sonar Control Unit"</a> .</li> </ol>
When the rear sonar system OFF switch is OFF, the sonar buzzer does not sound but indicator lamp lights up.	<ol style="list-style-type: none"> <li>1. Check sonar buzzer. Refer to <a href="#">DI-58, "SONAR BUZZER"</a> .</li> <li>2. Check harness and connections between sonar buzzer and sonar control unit.</li> <li>3. Replace sonar control unit. Refer to: <a href="#">DI-58, "Sonar Control Unit"</a> .</li> </ol>
When rear sonar system OFF switch is OFF, the rear sonar system OFF indicator lamp lights up and the sonar buzzer sounds intermittently (for about 4 seconds).	<ol style="list-style-type: none"> <li>1. Check harness between rear sonar sensors and sonar control unit for an open condition.</li> <li>2. Check rear sonar sensors for malfunction.</li> <li>3. Replace sonar control unit. Refer to <a href="#">DI-58, "Sonar Control Unit"</a> .</li> </ol>
The rear sonar system operates with the rear sonar system OFF switch ON.	<ol style="list-style-type: none"> <li>1. Check rear sonar system OFF switch for malfunction. Refer to <a href="#">DI-58, "REAR SONAR SYSTEM OFF SWITCH"</a> .</li> <li>2. Check rear sonar system OFF switch ground circuit.</li> <li>3. Check harness and connections between rear sonar system OFF switch and sonar control unit.</li> <li>4. Replace sonar control unit. Refer to <a href="#">DI-58, "Sonar Control Unit"</a> .</li> </ol>
When the selector lever is in the R position and the rear sonar system OFF switch is OFF, the sonar system does not operate.	<ol style="list-style-type: none"> <li>1. Check for PNP switch failure. Refer to <a href="#">AT-46, "SELF-DIAGNOSTIC PROCEDURE (WITH CONSULT-II)"</a> for 4-speed A/T or <a href="#">AT-445, "Diagnostic Procedure"</a> for 5-speed A/T.</li> <li>2. Check harness and connections between sonar control unit and PNP/reverse lamp circuits.</li> <li>3. Replace sonar control unit. Refer to <a href="#">DI-58, "Sonar Control Unit"</a> .</li> </ol>
When the rear sonar system OFF switch is OFF, the indicator lamp lights up and buzzer sounds although there is no obstacle within the detection range.	<ol style="list-style-type: none"> <li>1. Check for adhesion of snow, mud, or other foreign objects to rear sonar sensors; dew condensation; etc. Refer to <a href="#">DI-54, "Pre-diagnosis Inspection"</a> .</li> <li>2. Check harness and connections between rear sonar sensors and sonar control unit.</li> <li>3. Check rear sonar sensors for malfunction.</li> <li>4. Replace sonar control unit. Refer to <a href="#">DI-58, "Sonar Control Unit"</a> .</li> </ol>
The rear sonar sensors do not operate according to the distance between each sensor and the obstacle. (There is a large error in the obstacle detection distance.)	<ol style="list-style-type: none"> <li>1. Check rear sonar sensors for malfunction.</li> <li>2. Replace sonar control unit. Refer to <a href="#">DI-58, "Sonar Control Unit"</a> .</li> </ol>

A  
B  
C  
D  
E  
F  
G  
H  
I  
J  
DI  
L  
M

# REAR SONAR SYSTEM

EKS00FGD

## Component Inspection SONAR BUZZER

Disconnect the sonar buzzer connector M117, and apply battery voltage (approx. 12V) to terminal +. Check the buzzer operation when terminal - is connected to battery ground.

	Terminal to be inspected	Condition	Operation
Sonar buzzer	+	Approx. 12V	Sonar buzzer sounds
	-	Ground	

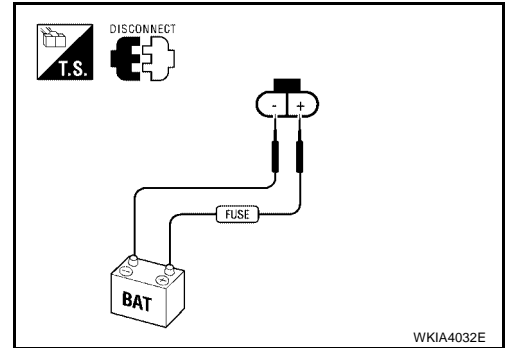

## REAR SONAR SYSTEM OFF SWITCH

Disconnect the rear sonar system OFF switch connector M116. Check continuity between the following terminals.

Rear sonar system OFF switch	Terminal to be inspected	Continuity
ON	6 - 7	Yes
OFF		No

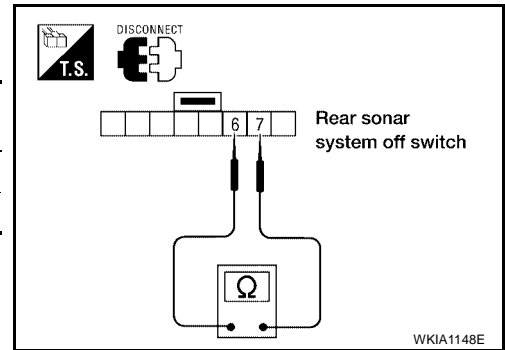

## REAR SONAR SYSTEM OFF INDICATOR

Disconnect the rear sonar system OFF switch connector M116, and apply battery voltage (approx. 12V) to terminal 3. Check the rear sonar system OFF indicator operation when terminal 2 is connected to battery ground.

	Terminal to be inspected	Condition	Operation
Rear sonar system OFF switch	3	Approx. 12V	Rear sonar system OFF indicator lights
	2	Ground	

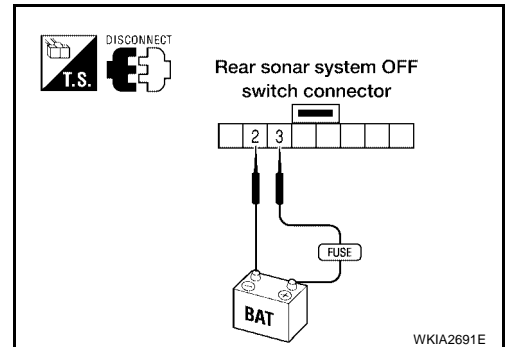

## Rear Sonar Sensors REMOVAL AND INSTALLATION

EKS00FGE

Refer to [EI-16, "Removal and Installation"](#) for rear sonar sensor removal and installation procedures.

## Sonar Control Unit REMOVAL AND INSTALLATION

EKS00GAQ

### Removal

1. Remove the rear lower finisher assembly LH. Refer to [EI-32, "LEFT SIDE"](#) to gain access to sonar control unit.
2. Disconnect electrical connector then remove sonar control unit. Refer to [DI-49, "Component Parts and Harness Connector Location"](#).

### INSTALLATION

Installation is in the reverse order of removal.

# REAR VIEW MONITOR

PF0:28260

EKS00FPV

## REAR VIEW MONITOR

### Component Parts and Harness Connector Location

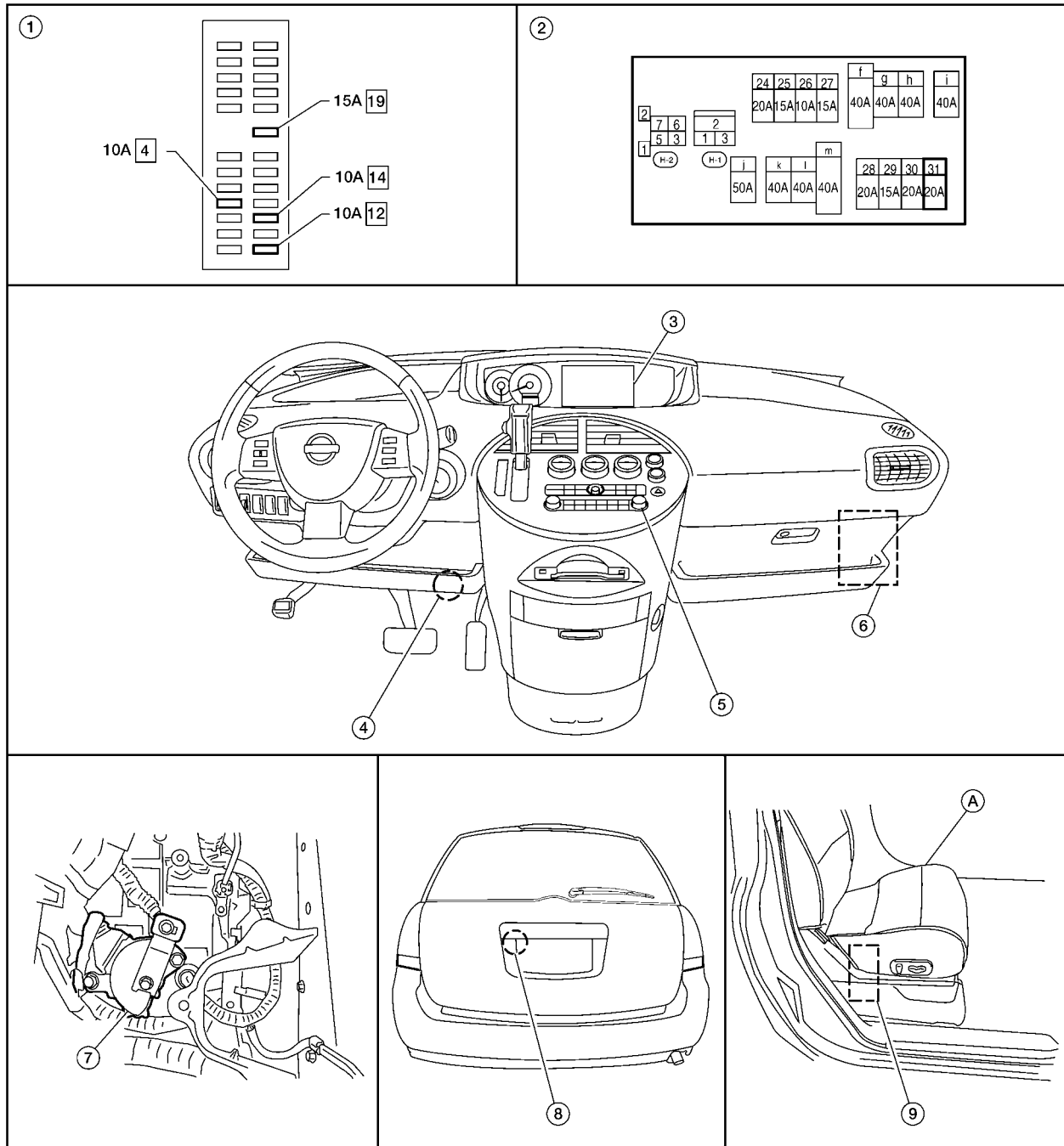

- |  |                              |                                       |
|--|------------------------------|---------------------------------------|
| 1. Fuse block (J/B)  | 2. Fuse and fusible link box | 3. Display unit M93                   |
| 4. Data link connector M22   | 5. AV switch M98             | 6. Display control unit M94, M95      |
| 7. Park/neutral position (PNP) switch F29 (view with battery tray removed) | 8. Rear view camera D518     | 9. Rear view camera control unit P125 |
|  |                              | A. Passenger seat                     |

WKIA4196E

# REAR VIEW MONITOR

EKS00FPW

## System Description

- When the A/T selector is in the reverse position, the display unit shows a view to the rear of the vehicle.
- Lines which indicate the vehicle clearance and distances are also displayed.

## POWER SUPPLY AND GROUND

Power is supplied at all times

- through 20A fuse (No. 31, located in the fuse and fusible link box)
- to rear view camera control unit terminal 1.

When ignition switch is in ACC or ON position, power is supplied

- through 10A fuse [No. 4, located in the fuse block (J/B)]
- to rear view camera control unit terminal 2.

Ground is supplied

- to rear view camera control unit terminal 3
- through grounds B117 and B132
- to rear view camera terminal 2
- through grounds D403 and D404.

## AV COMMUNICATION LINE

Rear view camera control unit is connected to the following units with AV communication line. Each unit transmits/receives data with AV communication line.

- NAVI control unit (with NAVI)
- Display unit
- Display control unit
- AV switch

## REAR VIEW CAMERA OPERATION

When ignition switch is in ON or START position, power is supplied

- through 10A fuse [No. 14, located in the fuse block (J/B)]
- to park/neutral position (PNP) switch terminal 2.

When A/T selector lever is in reverse position, power is supplied

- through park/neutral position (PNP) switch terminal 4
- to rear view camera control unit terminal 4.

Then, rear view camera control unit sends camera ON signal

- through rear view camera control unit terminal 8
- to rear view camera terminal 1.

An image taken by rear view camera is sent

- through rear view camera terminals 3 and 4
- to rear view camera control unit terminals 9 and 10.

Then an image is sent

- through rear view camera control unit terminals 11 and 12
- to display unit terminals 4 and 15.

An image of rear view will be projected on the display.

## Side Distance Guideline

When A/T selector lever is in reverse position, rear view camera control unit is sent rear view camera guideline image

- through rear view camera control unit terminals 11 and 12
- to display unit terminals 4 and 15.

Rear view camera guideline will be projected on the display.

Display shows image from rear view camera image and rear view camera guideline.

# REAR VIEW MONITOR

## Schematic

EKS00FPX

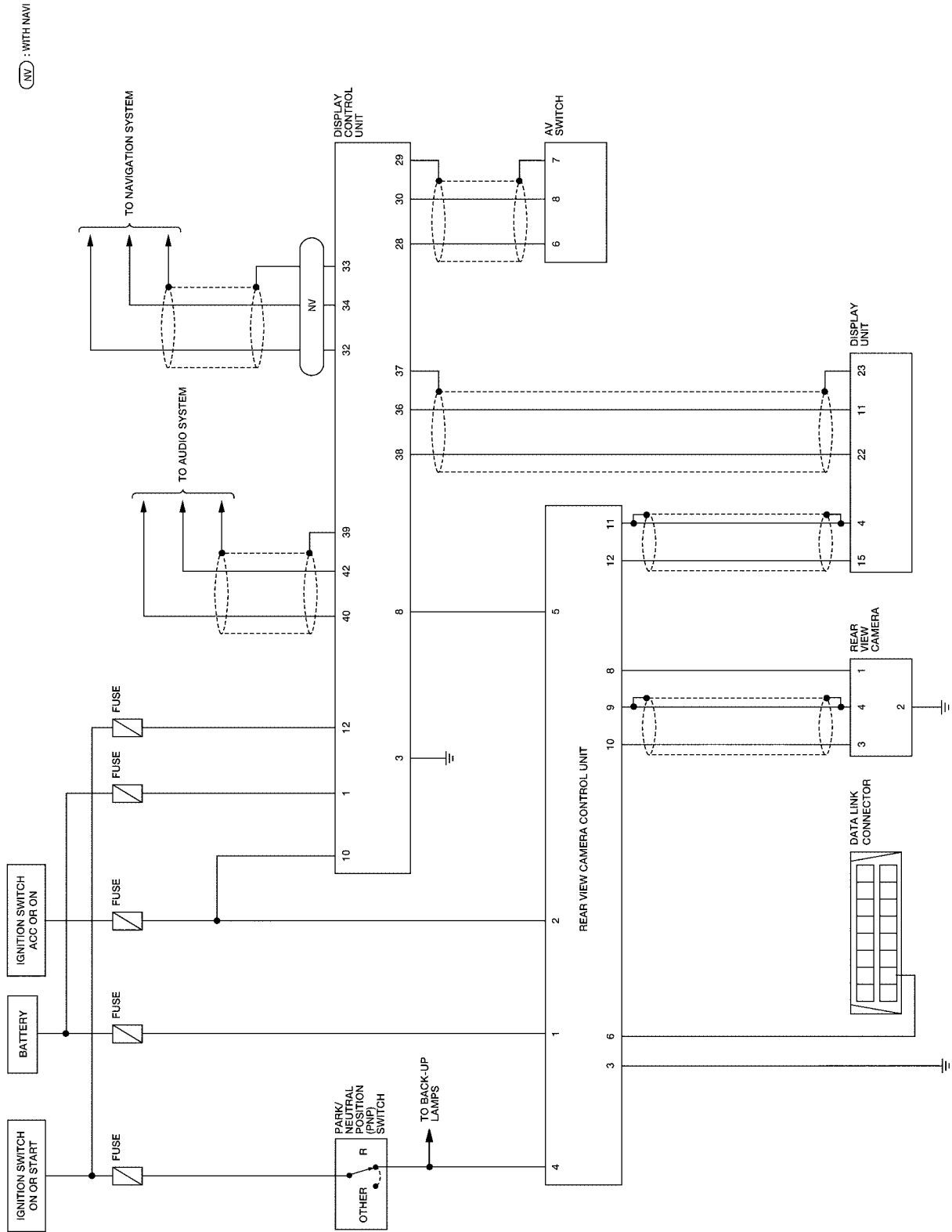

A  
B  
C  
D  
E  
F  
G  
H  
I  
J  
DI  
L  
M

# REAR VIEW MONITOR

EKS00FPY

## Wiring Diagram — R/VIEW —

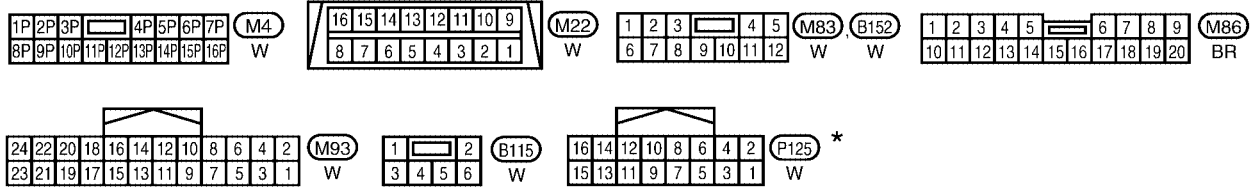
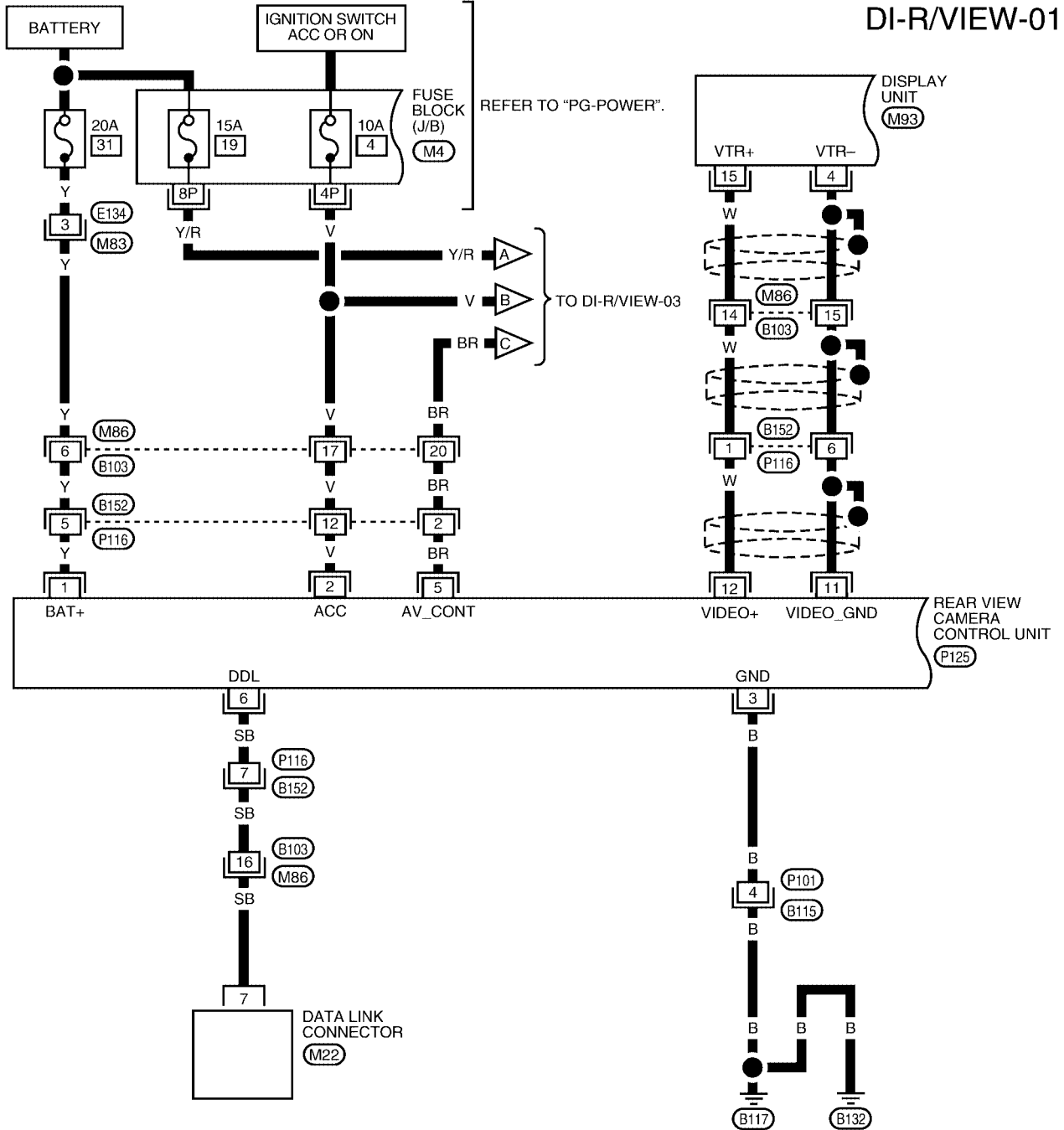

\*: THIS CONNECTOR IS NOT SHOWN IN "HARNESS LAYOUT" OF PG SECTION.

WKWA5234E

# REAR VIEW MONITOR

DI-R/VIEW-02

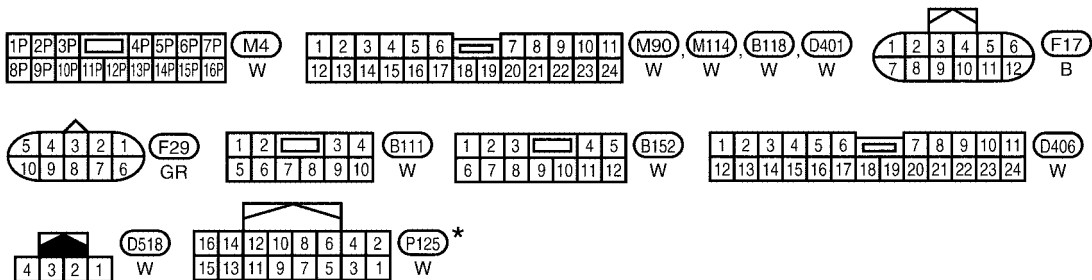
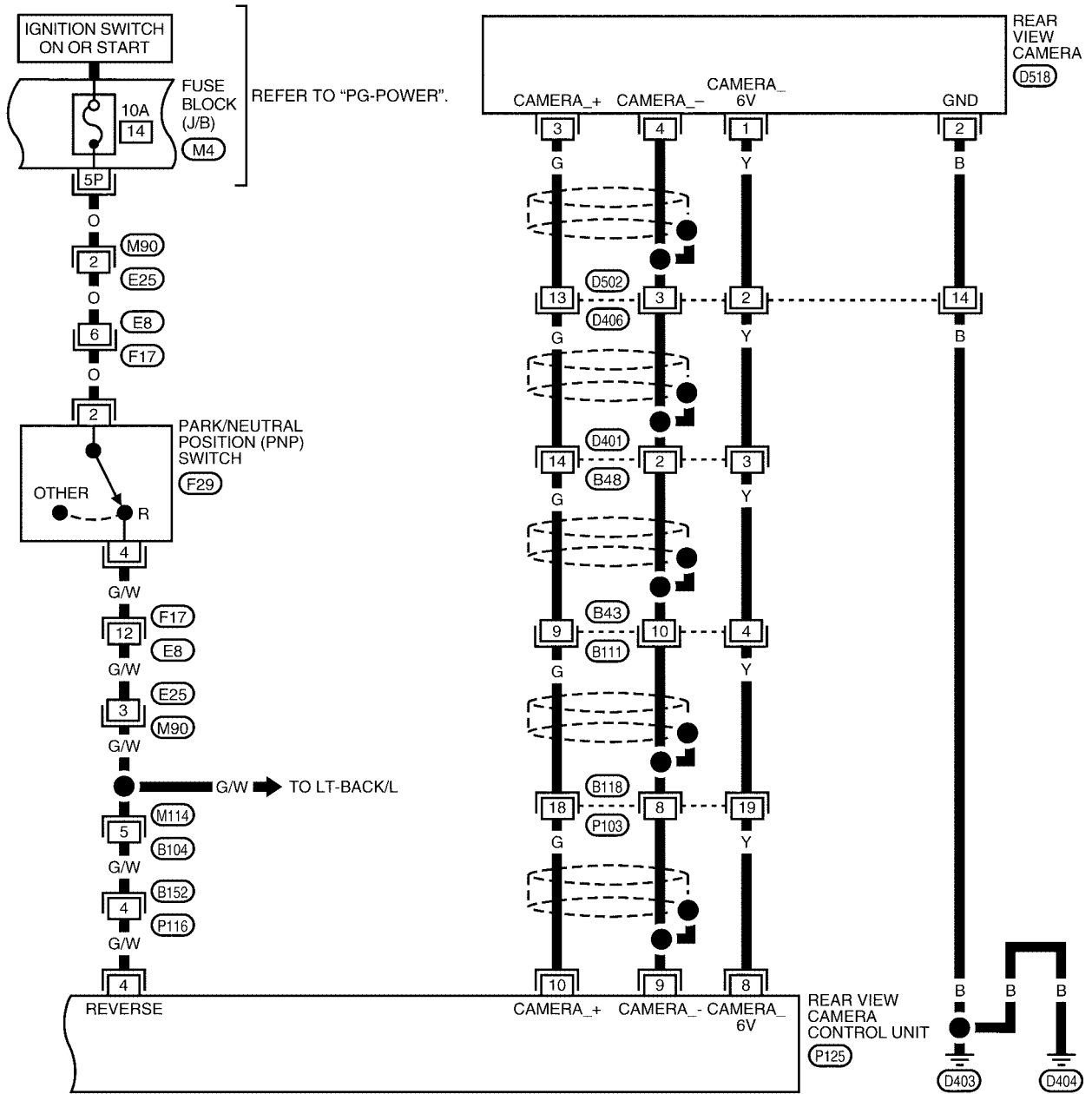

\*: THIS CONNECTOR IS NOT SHOWN IN "HARNESS LAYOUT" OF PG SECTION.

WKWA3146E

# REAR VIEW MONITOR

## DI-R/VIEW-03

(NV) : WITH NAVI

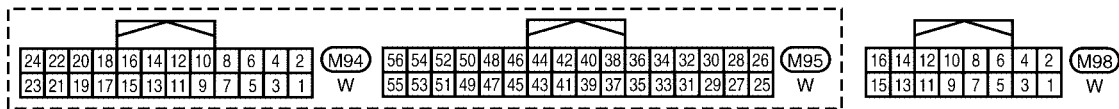
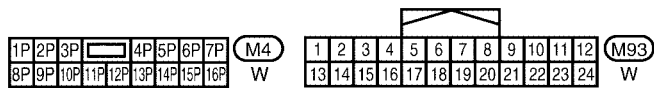
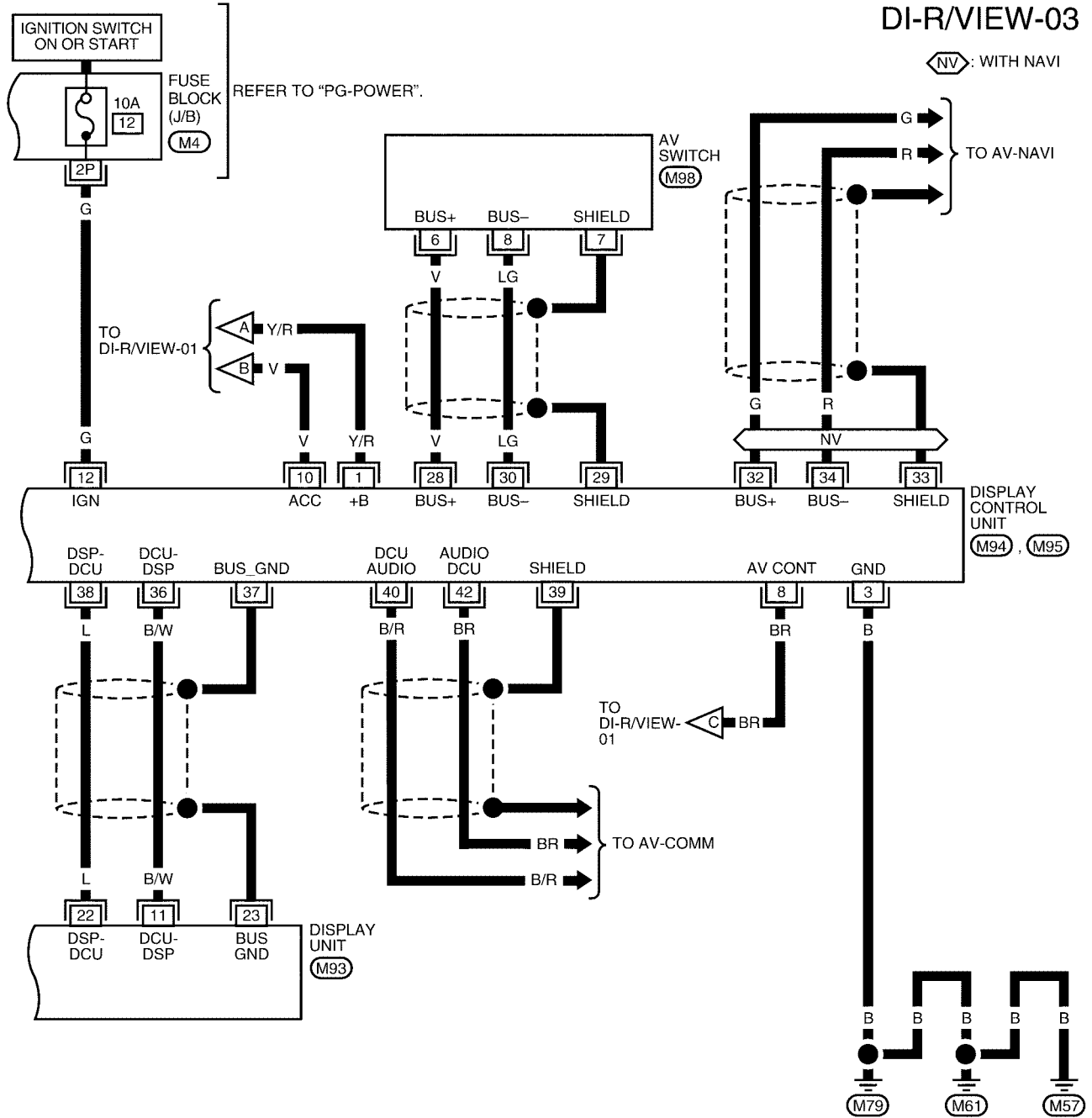

WKWA3147E



# REAR VIEW MONITOR

## Terminals and Reference Value for Rear View Camera Control Unit

EKS00FPZ

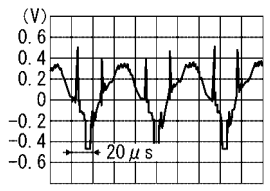
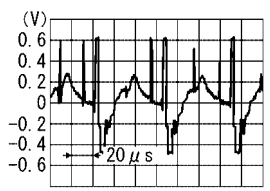
Terminal No.	Wire color	Item	Condition		Reference value (V) (Approx.)
			Ignition switch	Operation	
1	Y	Battery power	OFF	—	Battery voltage
2	V	ACC power	ACC	—	Battery voltage
3	B	Ground	OFF	—	0
4	G/W	Reverse signal input	ON	A/T selector lever R position	Battery voltage
				A/T selector lever in other than R position	0
5	BR	AV Control	ON	A/T selector lever R position	0
				—	0
6	SB	DDL	—	—	—
8	Y	Camera power output	ON	A/T selector lever R position	6
9	—	Camera image input (-)	ON	—	0
10	G	Camera image input (+)	ON	A/T selector lever R position	 <p style="text-align: right; font-size: small;">SKIA4894E</p>
11	—	Shield ground	—	—	—
12	W	Composite image output	ON	A/T selector lever R position	 <p style="text-align: right; font-size: small;">SKIA4896E</p>

A  
B  
C  
D  
E  
F  
G  
H  
I  
J  
DI  
L  
M

# REAR VIEW MONITOR

## CONSULT-II Function (REARVIEW CAMERA)

EKS00FQ0

CONSULT-II can display each diagnostic item using the diagnostic test modes shown following.

REARVIEW CAMERA diagnostic mode	Description
WORK SUPPORT	Supports inspection and adjustments. Commands are transmitted to the rearview camera control unit for setting the status suitable for required operation, input/output signals are received from the rearview camera control unit and received data is displayed.
DATA MONITOR	Displays rearview camera control unit input/output data in real time.
ECU PART NUMBER	Rearview camera control unit part number can be read.

## CONSULT-II BASIC OPERATION

### CAUTION:

If CONSULT-II is used with no connection of CONSULT-II CONVERTER, malfunctions might be detected in self-diagnosis depending on control unit which carries out CAN communication.

1. With the ignition switch OFF, connect CONSULT-II and CONSULT-II CONVERTER to the data link connector, then turn ignition switch ON.

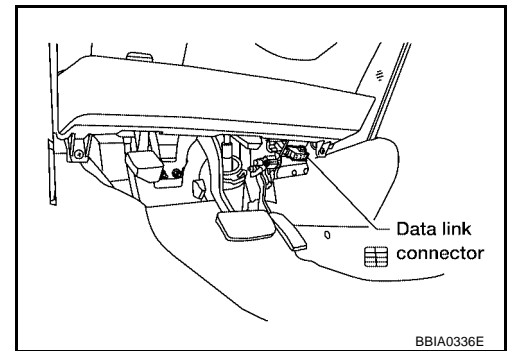

2. Touch "START (NISSAN BASED VHCL)".

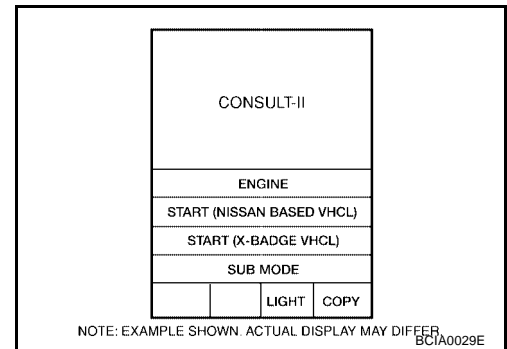

3. Touch "REARVIEW CAMERA" on "SELECT SYSTEM" screen. If "REARVIEW CAMERA" is not indicated, go to [GI-38, "CONSULT-II Data Link Connector \(DLC\) Circuit"](#).

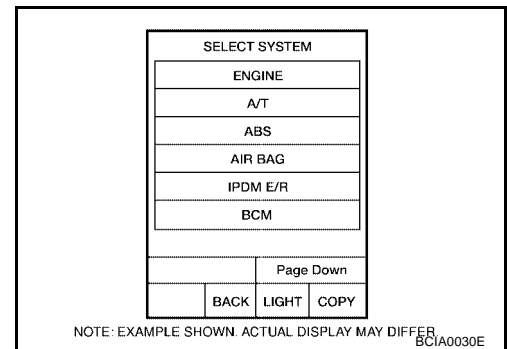

# REAR VIEW MONITOR

- Select "WORK SUPPORT", "DATA MONITOR" or "ECU PART NUMBER".

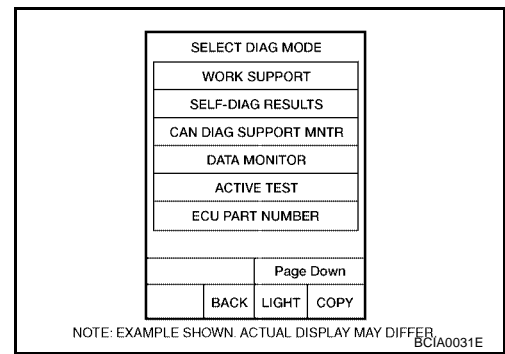

## WORK SUPPORT

### Operation Procedure

- Touch "WORK SUPPORT" on "SELECT DIAG MODE" screen.
- Touch either "SELCT GUIDELINE PATTERN" or "ADJ GUIDELINE POSITION" on the "SELECT WORK ITEM" screen.

SELCT GUIDELINE PATTERN	Side distance guideline is optional from two patterns.
ADJ GUIDELINE POSITION	Side distance guideline is adjustable toward up and down, right and left.

Refer to [DI-68, "SIDE DISTANCE GUIDELINE CORRECTION PROCEDURE"](#) for detail.

## DATA MONITOR

### Operation Procedure

- Touch "DATA MONITOR" on "SELECT DIAG MODE" screen.
- Touch either "ALL SIGNALS" or "SELECTION FROM MENU" on the "SELECT MONITOR ITEM" screen.

ALL SIGNALS	Monitors all signals.
SELECTION FROM MENU	Selects and monitors individual signal.

- When "SELECTION FROM MENU" is selected, touch individual items to be monitored. When "ALL SIGNALS" is selected, all items will be monitored.
- Touch "START".
- Touch "RECORD" while monitoring, then the status of the monitored item can be recorded. To stop recording, touch "STOP".

### Display Item List

Display item [Unit]	ALL SIGNALS	SELECTION FROM MENU	Contents
R POSI SIG [ON/OFF]	X	X	Indicates [ON/OFF] condition of R position signal input.

# REAR VIEW MONITOR

EKS00FQ1

## Side Distance Guideline Correction

This mode is used to modify the side distance guidelines if they are dislocated from the rear view monitor image, because of variations of body/camera mounting conditions.

### SIDE DISTANCE GUIDELINE CORRECTION PROCEDURE

1. Create a correction line to modify the screen.  
Draw lines on the rearward of the vehicle passing through the following points: 200 mm (7.87 inch) from both sides of the vehicle, and
  - \*1: 0.5 m (1.5 feet)
  - \*2: 1 m (3 feet)
  - \*3: 2 m (7 feet)
  - \*4: 3 m (10 feet)and from the rear end of the bumper
2. With the ignition switch OFF, connect CONSULT-II and CONSULT-II CONVERTER to the data link connector, then turn ignition switch ON. Touch "REARVIEW CAMERA" on "SELECT SYSTEM" screen.

**CAUTION:**

**Stop engine for safety when correcting side distance guideline.**

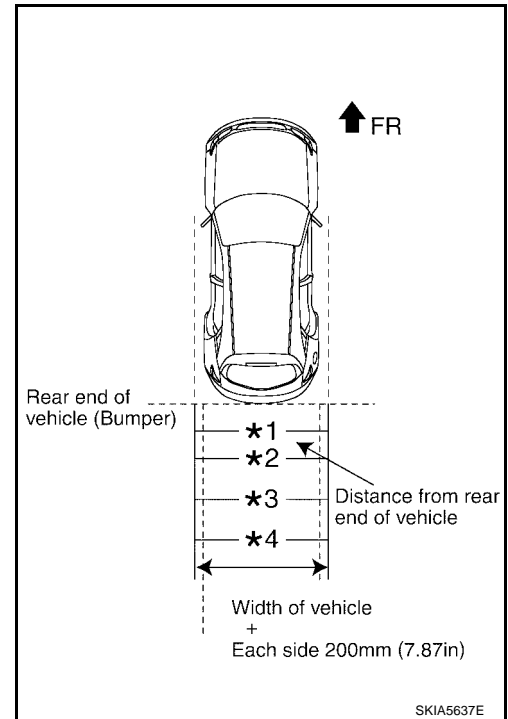

3. Shift the A/T selector lever to R position.

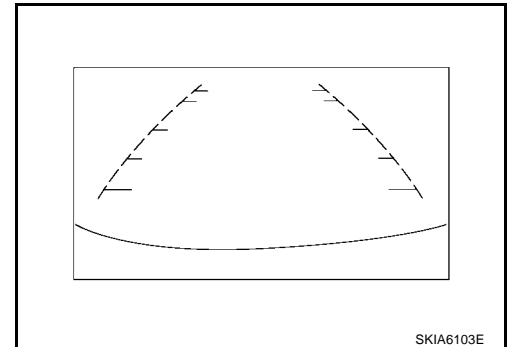

4. Touch "SELCT GUIDELINE PATTERN" on "SELECT WORK ITEM" screen.

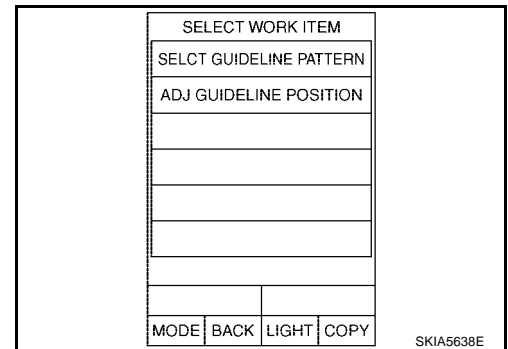



# REAR VIEW MONITOR

EKS00FQ2

## Power Supply and Ground Circuit Inspection

### 1. CHECK FUSES

Check for blown rear view camera system fuses.

Unit	Power source	Fuse No.
Rear view camera control unit	Battery	31
	Ignition switch ACC or ON	4

OK or NG

OK >> GO TO 2.

NG >> If fuse is blown, be sure to eliminate cause of problem before installing new fuse. Refer to [PG-4, "POWER SUPPLY ROUTING CIRCUIT"](#).

### 2. CHECK POWER SUPPLY CIRCUIT

1. Disconnect rear view camera control unit connector.
2. Check voltage between rear view camera control unit and ground.

Terminals		(-)	OFF	ACC
(+)	Connector			
	Terminal			
	P125	1	Battery voltage	Battery voltage
		2	0V	Battery voltage

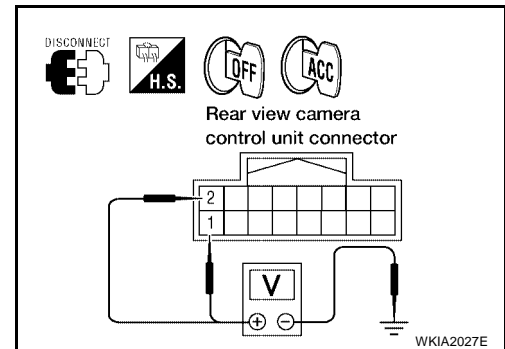

OK or NG

OK >> GO TO 3.

NG >> Check harness for open between rear view camera control unit and fuse.

### 3. CHECK REAR VIEW CAMERA CONTROL UNIT GROUND CIRCUIT

1. Turn ignition switch OFF.
2. Check continuity between rear view camera control unit harness connector P125 terminal 3 and ground.

**Continuity should exist.**

OK or NG

OK >> GO TO 4.

NG >> Repair harness or connector.

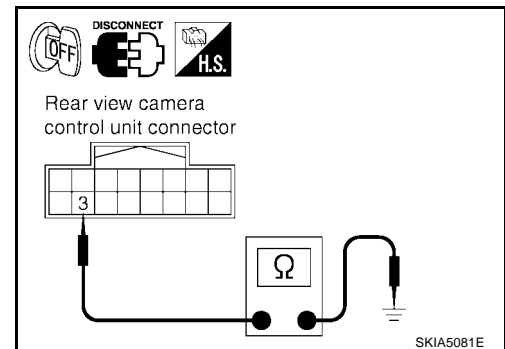

### 4. CHECK REAR VIEW CAMERA GROUND CIRCUIT

1. Disconnect rear view camera connector.
2. Check continuity between rear view camera harness connector D518 terminal 2 and ground.

**Continuity should exist.**

OK or NG

OK >> Inspection End.

NG >> Repair harness or connector.

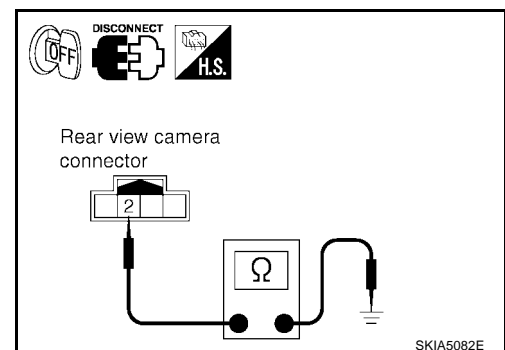

# REAR VIEW MONITOR

## Rear View Is Not Displayed With The A/T Selector Lever In R Position

EKS00FQ3

### 1. BACK-UP LAMP INSPECTION

1. Turn ignition switch ON.
2. Shift A/T selector lever to R position.

Does back-up lamp illuminate?

- YES >> GO TO 2.  
NO >> Check back-up lamp system. Refer to [LT-114, "BACK-UP LAMP"](#) .

### 2. CHECK REVERSE POSITION INPUT SIGNAL

#### ④ With CONSULT-II

Select "DATA MONITOR" of "REARVIEW CAMERA". Operate ignition switch with "R POSI SIG" of "DATA MONITOR" and check operate status.

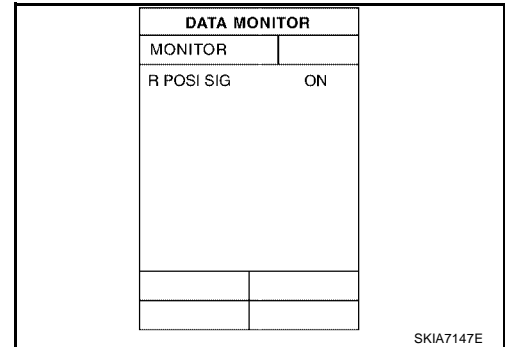

#### ⊗ Without CONSULT-II

1. Turn ignition switch OFF.
2. Disconnect rear view camera control unit connector.
3. Turn ignition switch ON.
4. Shift A/T selector lever to R position.
5. Check voltage between rear view camera control unit harness connector P125 terminal 4 and ground.

**Battery voltage should exist.**

OK or NG

- OK >> GO TO 3.  
NG >> Check harness for open or short between rear view camera control unit and park/neutral position (PNP) switch.

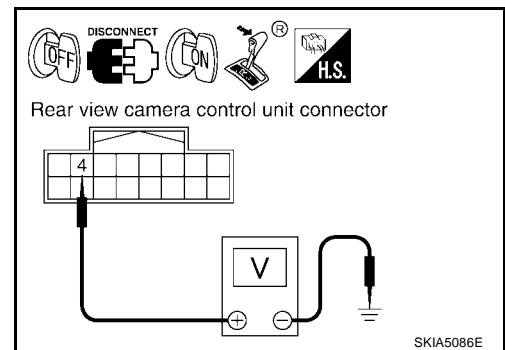

### 3. CHECK DISPLAY CONTROL UNIT OUTPUT SIGNAL

Check voltage between rear view camera control unit harness connector P125 terminal 5 and ground.

**Voltage : Approx. 5V**

OK or NG

- OK >> GO TO 5.  
NG >> GO TO 4.

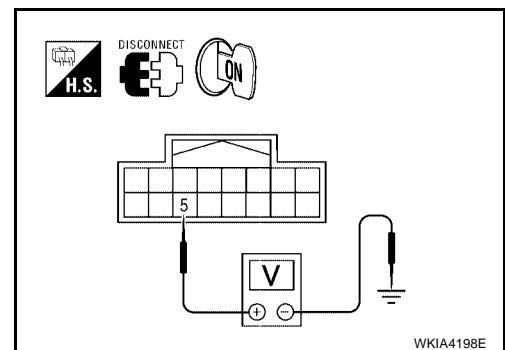

# REAR VIEW MONITOR

## 4. CHECK DISPLAY CONTROL UNIT CIRCUIT

1. Turn ignition switch OFF.
2. Disconnect display control unit connector.
3. Check continuity between rear view camera control unit harness connector P125 terminal 5 and display control unit harness connector M94 terminal 8.

**Continuity should exist.**

4. Check continuity between rear view camera control unit harness connector P125 terminal 5 and ground.

**Continuity should not exist.**

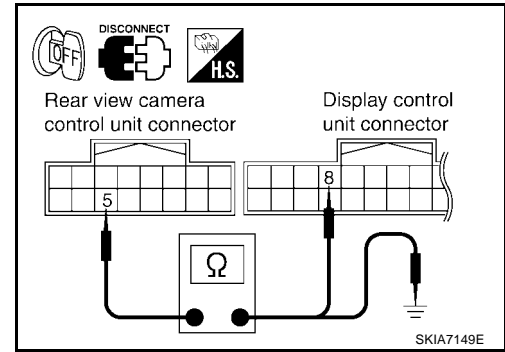

OK or NG

- OK >> Replace display control unit. Refer to [AV-243, "REMOVAL AND INSTALLATION"](#).
- NG >> Repair harness or connector.

## 5. CHECK AV CONTROL SIGNAL

1. Turn ignition switch OFF.
2. Connect rear view camera control unit connector.
3. Turn ignition switch ON.
4. Shift A/T selector lever to R position.
5. Check voltage between rear view camera control unit harness connector P125 terminal 5 and ground.

**Voltage : Approx. 0V**

OK or NG

- OK >> GO TO 6.
- NG >> Replace rear view camera control unit. Refer to [DI-75, "Rear View Camera Control Unit"](#).

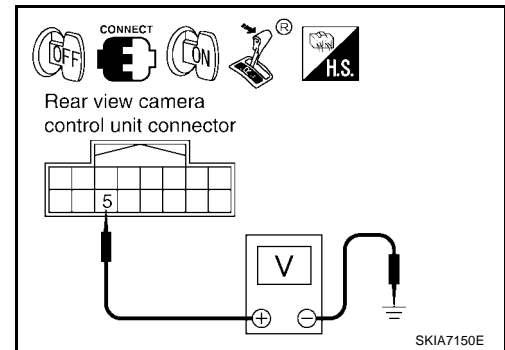

## 6. CHECK REAR VIEW CAMERA OPEN CIRCUIT

1. Turn ignition switch OFF.
2. Disconnect rear view camera connector.
3. Check continuity between rear view camera control unit harness connector P125 terminal 8 and rear view camera harness connector D518 terminal 1.

**Continuity should exist.**

4. Check continuity between rear view camera control unit harness connector P125 terminal 9 and rear view camera harness connector D518 terminal 4.

**Continuity should exist.**

5. Check continuity between rear view camera control unit harness connector P125 terminal 10 and rear view camera harness connector D518 terminal 3.

**Continuity should exist.**

OK or NG

- OK >> GO TO 7.
- NG >> Repair harness or connector.

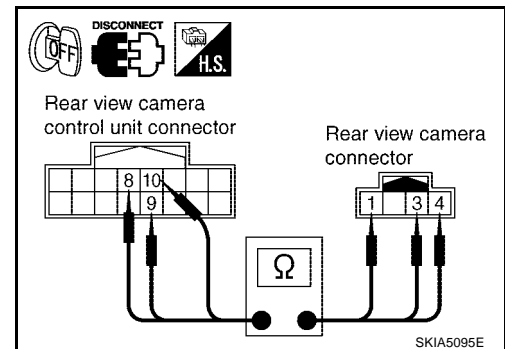



# REAR VIEW MONITOR

## 7. CHECK REAR VIEW CAMERA SHORT CIRCUIT

1. Check continuity between rear view camera control unit harness connector P125 terminal 8 and ground.

**Continuity should not exist.**

2. Check continuity between rear view camera control unit harness connector P125 terminal 9 and ground.

**Continuity should not exist.**

3. Check continuity between rear view camera control unit harness connector P125 terminal 10 and ground.

**Continuity should not exist.**

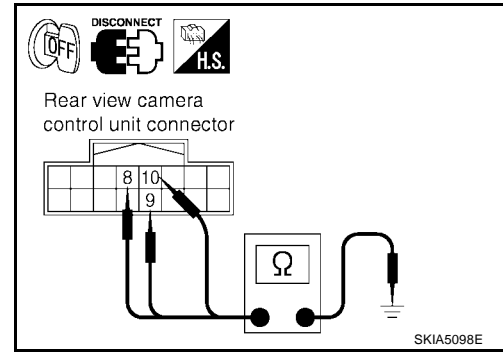

OK or NG

- OK >> GO TO 8.
- NG >> Repair harness on connector.

## 8. CHECK POWER SUPPLY AND GROUND CIRCUIT

Check power supply and ground circuit. Refer to [DI-70, "Power Supply and Ground Circuit Inspection"](#).

OK or NG

- OK >> GO TO 9.
- NG >> Repair power supply or ground circuit.

## 9. CHECK REAR VIEW CAMERA CONTROL UNIT OUTPUT SIGNAL

1. Connect rear view camera control unit connector.
2. Turn ignition switch ON.
3. Shift A/T selector lever to R position.
4. Check voltage between rear view camera control unit harness connector P125 terminal 8 and ground.

**Voltage : Approx. 6V**

OK or NG

- OK >> GO TO 10.
- NG >> Replace the rear view camera control unit. Refer to [DI-75, "Rear View Camera Control Unit"](#).

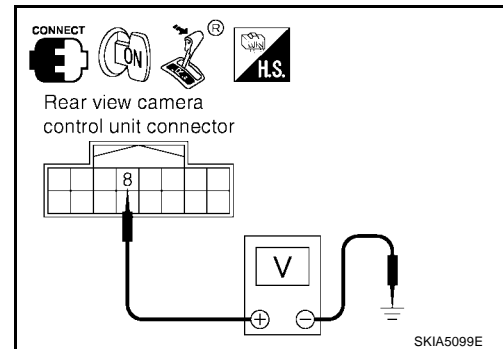

## 10. CHECK REAR VIEW CAMERA SIGNAL

1. Connect rear view camera connector.
2. Turn ignition switch ON.
3. Shift A/T selector lever to R position.
4. Check voltage signal between rear view camera control unit harness connector P125 terminal 10 and ground.

**10 - Ground:**

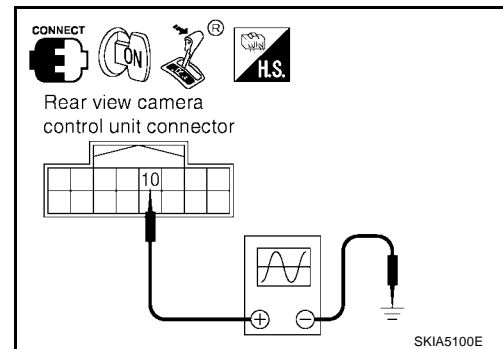
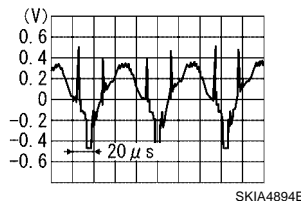

OK or NG

- OK >> GO TO 11.
- NG >> Replace the rear view camera. Refer to [DI-75, "Rear View Camera"](#).

# REAR VIEW MONITOR

## 11. CHECK COMPOSITE SIGNAL OPEN OR SHORT CIRCUIT

1. Turn ignition switch OFF.
2. Disconnect rear view camera control unit connector and display unit connector.
3. Check continuity between rear view camera control unit harness connector P125 (A) terminal 12 and display unit harness connector M93 (B) terminal 15.

**Continuity should exist.**

4. Check continuity between rear view camera control unit harness connector P125 (A) terminal 12 and ground.

**Continuity should not exist.**

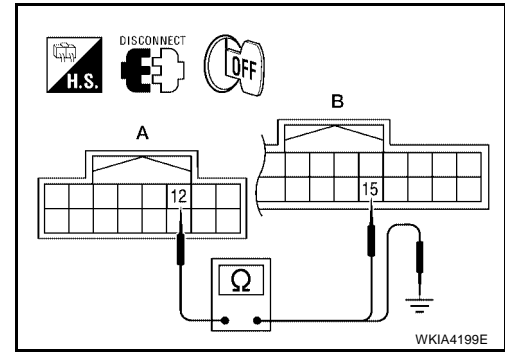

OK or NG

OK >> GO TO 12.

NG >> Repair harness or connector.

## 12. CHECK COMPOSITE SIGNAL GROUND CIRCUIT

1. Check continuity between rear view camera control unit harness connector P125 (A) terminal 11 and display unit harness connector M93 (B) terminal 4.

**Continuity should exist.**

2. Check continuity between rear view camera control unit harness connector P125 (A) terminal 11 and ground.

**Continuity should not exist.**

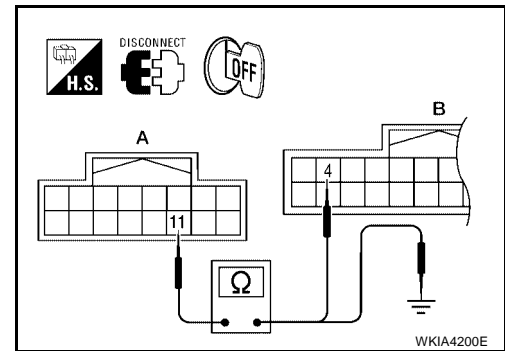

OK or NG

OK >> GO TO 13.

NG >> Repair harness or connector.

## 13. CHECK REAR VIEW CAMERA CONTROL UNIT COMPOSITE SIGNAL

1. Connect rear view camera control unit connector and display unit connector.
2. Turn ignition switch ON.
3. Check voltage signal between rear view camera control unit harness connector P125 terminal 12 and ground.

**12 - Ground:**

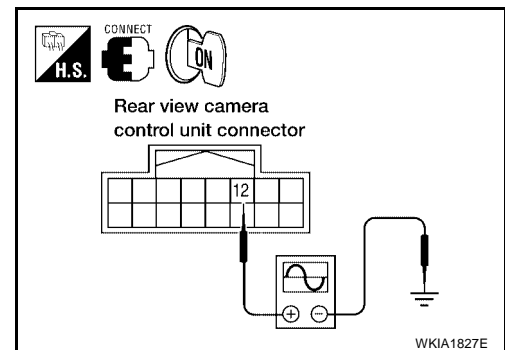
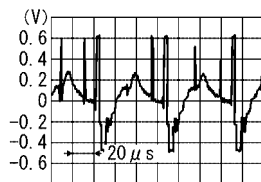

OK or NG

OK >> Replace the display unit. Refer to [AV-244, "REMOVAL AND INSTALLATION"](#).

NG >> Replace the rear view camera control unit. Refer to [DI-75, "Rear View Camera Control Unit"](#).

# REAR VIEW MONITOR

## Rear View Camera Control Unit REMOVAL AND INSTALLATION

EKS00FQ4

### Removal

1. Disconnect battery negative terminal.
2. Remove front passenger seat. Refer to [SE-88, "FRONT SEAT"](#) .
3. Disconnect rear view camera control unit connector.
4. Remove screws (1) and remove rear view camera control unit (2).

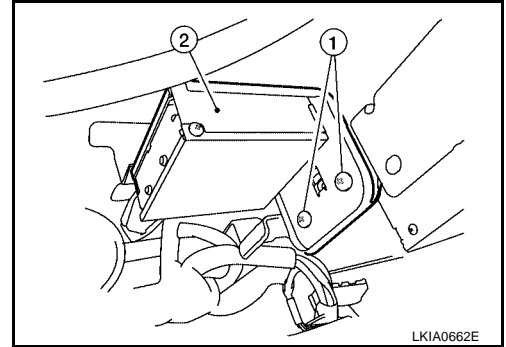

### Installation

Installation is in the reverse order of removal.

## Rear View Camera REMOVAL AND INSTALLATION

EKS00FQ5

### Removal

1. Remove back door lower finisher. Refer to [EI-36, "BACK DOOR LOWER FINISHER"](#) .
2. Remove license lamp finisher. Refer to [EI-23, "LICENSE LAMP FINISHER"](#) .
3. Disconnect rear view camera connector (1).
4. Remove rear view camera screw and remove rear view camera.

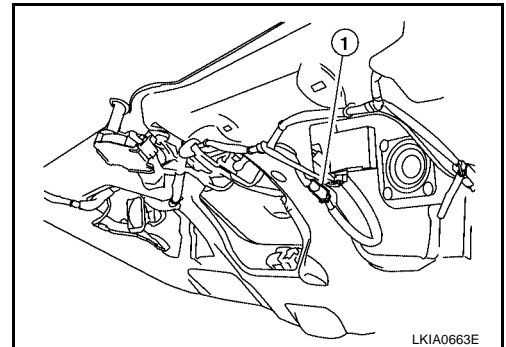

### Installation

#### NOTE:

After installing rear view camera, perform side distance guideline correction procedure. Refer to [DI-68, "SIDE DISTANCE GUIDELINE CORRECTION PROCEDURE"](#) .

Installation is in the reverse order of removal.

# REAR VIEW MONITOR

---