

A
B
C

SECTION PS

POWER STEERING SYSTEM

CONTENTS

SERVICE INFORMATION	Removal and Installation	9	F
PRECAUTIONS	Disassembly and Assembly	12	
Precaution for Supplemental Restraint System (SRS) "AIR BAG" and "SEAT BELT PRE-TEN- SIONER"	Inspection	12	
Precaution for Steering System	POWER STEERING GEAR AND LINKAGE	14	PS
PREPARATION	On-Vehicle Service	14	
Special Service Tool	Removal and Installation	15	H
Commercial Service Tool	Disassembly and Assembly	17	
NOISE, VIBRATION, AND HARSHNESS (NVH) TROUBLESHOOTING	Adjustment of Rack Sliding Force	19	
NVH Troubleshooting Chart	POWER STEERING OIL PUMP	21	I
POWER STEERING FLUID	On-Vehicle Service	21	
Checking Fluid Level	Removal and Installation	21	
Checking Fluid Leakage	Disassembly and Assembly	23	J
Bleeding Hydraulic System	HYDRAULIC LINE	24	
STEERING WHEEL	Removal and Installation	24	K
On-Vehicle Service	SERVICE DATA AND SPECIFICATIONS (SDS)	25	
Removal and Installation	General Specification	25	L
STEERING COLUMN	Steering Wheel	25	
	Steering Column	25	M
	Power Steering	25	
	Steering Gear and Linkage	25	N
			O
			P

PRECAUTIONS

< SERVICE INFORMATION >

SERVICE INFORMATION

PRECAUTIONS

Precaution for Supplemental Restraint System (SRS) "AIR BAG" and "SEAT BELT PRE-TENSIONER"

INFOID:000000001718382

The Supplemental Restraint System such as "AIR BAG" and "SEAT BELT PRE-TENSIONER", used along with a front seat belt, helps to reduce the risk or severity of injury to the driver and front passenger for certain types of collision. This system includes seat belt switch inputs and dual stage front air bag modules. The SRS system uses the seat belt switches to determine the front air bag deployment, and may only deploy one front air bag, depending on the severity of a collision and whether the front occupants are belted or unbelted. Information necessary to service the system safely is included in the SRS and SB section of this Service Manual.

WARNING:

- To avoid rendering the SRS inoperative, which could increase the risk of personal injury or death in the event of a collision which would result in air bag inflation, all maintenance must be performed by an authorized NISSAN/INFINITI dealer.
- Improper maintenance, including incorrect removal and installation of the SRS, can lead to personal injury caused by unintentional activation of the system. For removal of Spiral Cable and Air Bag Module, see the SRS section.
- Do not use electrical test equipment on any circuit related to the SRS unless instructed to in this Service Manual. SRS wiring harnesses can be identified by yellow and/or orange harnesses or harness connectors.

Precaution for Steering System

INFOID:000000001718383

- Before disassembly, thoroughly clean the outside of the unit.
- Disassembly should be done in a clean work area. It is important to prevent the internal parts from becoming contaminated by dirt or other foreign matter.
- For easier and proper assembly, place disassembled parts in order on a parts rack.
- Use nylon cloths or paper towels to clean the parts; common shop rags can leave lint that might interfere with their operation.
- Before inspection or reassembly, carefully clean all parts with a general purpose, non-flammable solvent.
- Before assembly, apply a coat of recommended Genuine NISSAN PSF or equivalent to hydraulic parts. Petroleum jelly may be applied to O-rings and seals. Do not use any grease.
- Replace all gaskets, seals and O-rings. Avoid damaging O-rings, seals and gaskets during installation. Perform functional tests whenever designated.

PREPARATION

< SERVICE INFORMATION >

PREPARATION

Special Service Tool

INFOID:000000001718384

The actual shapes of Kent-Moore tools may differ from those of special service tools illustrated here.

Tool number (Kent-Moore No.) Tool name	Description
KV48102500 (J-33914) Pressure gauge adapter	Measuring oil pressure
KV48103500 (J-26357 and J-26357-10) Pressure gauge	Measuring oil pressure
HT72520000 (J-25730-A) Ball joint remover	Removing ball joint
KV481J0010 (J-1859-A) Steering wheel puller	Removing steering wheel
KV481J0020 (J-42578) Steering wheel puller legs	Removing steering wheel

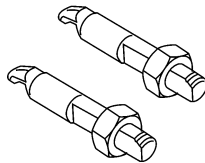
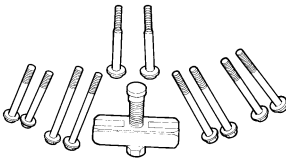
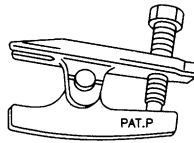
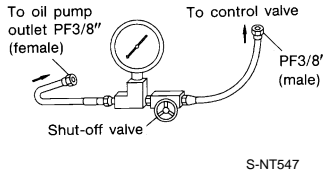
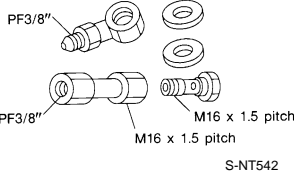

Commercial Service Tool

INFOID:000000001718385

A
B
C
D
E
F
PS
H
I
J
K
L
M
N
O
P

PREPARATION

< SERVICE INFORMATION >

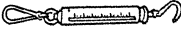
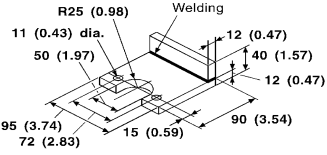
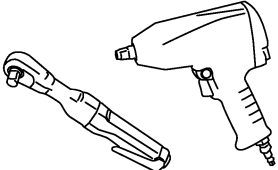
Tool number	Description
<p data-bbox="164 197 298 224">Spring gauge</p>  <p data-bbox="850 415 899 432">LST024</p>	<p data-bbox="1013 197 1430 254">Measuring steering wheel turning force or rack sliding force</p>
<p data-bbox="164 449 375 476">Oil pump attachment</p>  <p data-bbox="850 667 899 684">S-NT774</p>	<p data-bbox="1013 449 1414 506">Disassembling and assembling oil pump Unit: mm (in)</p>
<p data-bbox="164 701 272 728">Power tool</p>  <p data-bbox="850 919 915 936">PBIC0190E</p>	<p data-bbox="1013 701 1263 728">Loosening bolts and nuts</p>

NOISE, VIBRATION, AND HARSHNESS (NVH) TROUBLESHOOTING

< SERVICE INFORMATION >

NOISE, VIBRATION, AND HARSHNESS (NVH) TROUBLESHOOTING

NVH Troubleshooting Chart

INFOID:000000001718386

Use the chart below to help you find the cause of the symptom. If necessary, repair or replace these parts.

Symptom		Possible cause and SUSPECTED PARTS													Reference page									
		Fluid level	Air in hydraulic system	Tie-rod ball joint swinging force	Tie-rod ball joint rotating torque	Tie-rod ball joint end play	Steering gear fluid leakage	Steering wheel play	Steering gear rack sliding force	Drive belt looseness	Improper steering wheel	Improper installation or looseness or tilt lock lever	Mounting rubber deterioration	Steering column deformation or damage		Improper installation or looseness of steering column	Steering linkage looseness	DRIVE SHAFT	AXLE	SUSPENSION	TIRES	ROAD WHEEL	BRAKES	
Noise	Noise	x	x	x	x	x	x	x	x	x	x	x	x	x	x	x	x	x	x	x	x	x	x	PS-6
	Shake																							PS-6
	Vibration																							PS-17
	Shimmy																							PS-17
	Shudder																							PS-6
Shake	Noise																							PS-7
	Shake																							PS-19
	Vibration																							EM-12, "Checking Drive Belts"
	Shimmy																							PS-7
	Shudder																							PS-12
	Noise																							PS-12
	Shake																							PS-14
	Vibration																							PS-12
	Shimmy																							PS-12
	Shudder																							PS-14
	Noise																							FAX-4, "NVH Troubleshooting Chart"
	Shake																							FAX-4, "NVH Troubleshooting Chart"
	Vibration																							FSU-5, "NVH Troubleshooting Chart"
Shimmy																							WT-4, "NVH Troubleshooting Chart"	
Shudder																							WT-4, "NVH Troubleshooting Chart"	
Noise																							BR-4, "NVH Troubleshooting Chart"	
Shake																							BR-4, "NVH Troubleshooting Chart"	
Vibration																							BR-4, "NVH Troubleshooting Chart"	
Shimmy																							BR-4, "NVH Troubleshooting Chart"	
Shudder																							BR-4, "NVH Troubleshooting Chart"	

x: Applicable

A
B
C
D
E
F
G
H
I
J
K
L
M
N
O
P

PS

POWER STEERING FLUID

< SERVICE INFORMATION >

POWER STEERING FLUID

Checking Fluid Level

INFOID:000000001718387

Check fluid level, referring to the scale on reservoir tank.
Use **HOT** range for fluid temperatures of 50° – 80°C (122° – 176°F).
Use **COLD** range for fluid temperatures of 0° – 30°C (32° – 86°F).

CAUTION:

- Do not overfill.
- Do not reuse any used power steering fluid.
- Recommended fluid is Genuine NISSAN PSF or equivalent. Refer to [MA-11](#).

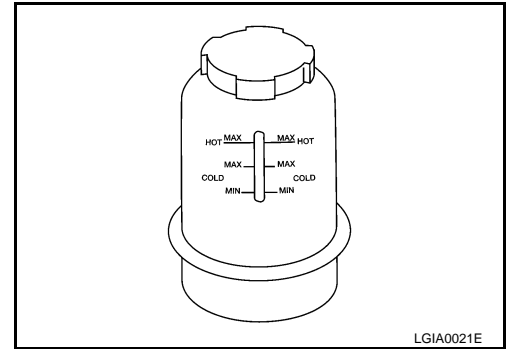

Checking Fluid Leakage

INFOID:000000001718388

Check the lines for improper attachment and for leaks, cracks, damage, loose connections, chafing and deterioration.

1. Run engine between idle speed and 1,000 rpm.
Make sure temperature of fluid in oil tank rises to 60° – 80°C (140° – 176°F).
2. Turn steering wheel right-to-left several times.
3. Hold steering wheel at each lock position for five seconds and carefully check for fluid leakage.

CAUTION:

Do not hold the steering wheel in a locked position for more than 15 seconds.

4. If fluid leakage at connectors is noticed, loosen flare nut and then retighten.
Do not overtighten connector as this can damage O-ring, washer and connector.
5. If fluid leakage from power steering oil pump is noticed, check the power steering oil pump. Refer to [PS-21, "On-Vehicle Service"](#).
6. Check steering gear boots for accumulation of power steering fluid, indicating a steering gear leak.

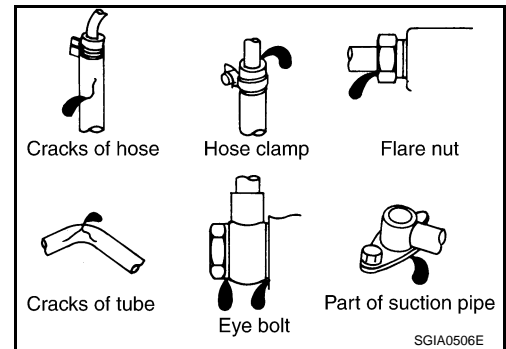

Bleeding Hydraulic System

INFOID:000000001718389

1. Raise the front end of vehicle until the wheels are clear of the ground.
2. Add Genuine NISSAN PSF or equivalent into the steering fluid reservoir tank to the specified level. Refer to [MA-11](#). Then quickly turn the steering wheel fully to right and left and lightly touch steering stoppers. Repeat steering wheel operation until the fluid level no longer decreases.

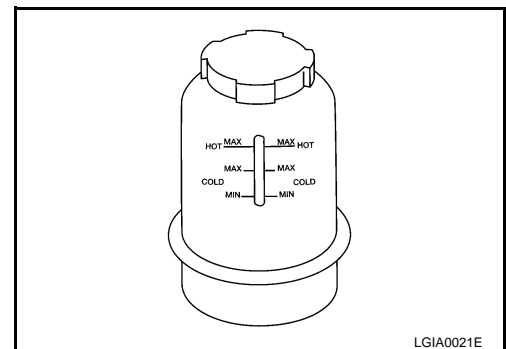

3. Start the engine then repeat step 2 above. Incomplete air bleeding will cause the following symptoms:
 - Air bubbles in reservoir tank
 - Clicking noise in oil pump
 - Excessive buzzing in oil pump

If this happens, bleed out the air repeating step 2 above. Fluid noise may occur in the valve or oil pump. This is common when the vehicle is stationary or while turning the steering wheel slowly. This does not affect the performance or durability of the system.

STEERING WHEEL

< SERVICE INFORMATION >

STEERING WHEEL

On-Vehicle Service

INFOID:000000001718390

CHECKING STEERING WHEEL PLAY

- With wheels in a straight-ahead position, check steering wheel play.

Steering wheel play : 35 mm (1.38 in) or less

- If it is not within specification, check the following for looseness or worn components:
 - Steering gear assembly
 - Steering column
 - Front suspension and axle
 - Check steering system for looseness while moving the steering wheel in all directions.

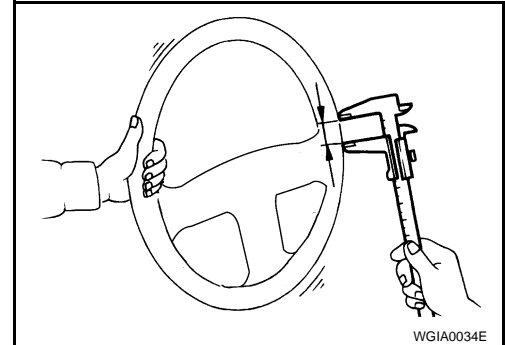

Axial end play : 0 mm (0 in)

CHECKING NEUTRAL POSITION ON STEERING WHEEL

Pre-checking

- Make sure that wheel alignment is correct. Refer to [FSU-19, "Front Wheel Alignment \(Unladen*1\)"](#).
- Verify that the steering gear is centered before removing the steering wheel.

Checking

1. Check that the steering wheel is in neutral position when driving straight ahead.
2. If it is not in neutral position, remove the steering wheel and reinstall it correctly.
3. If the neutral position is between two teeth, loosen tie-rod lock nuts. Turn the tie-rods by the same amount in opposite directions on both left and right sides.

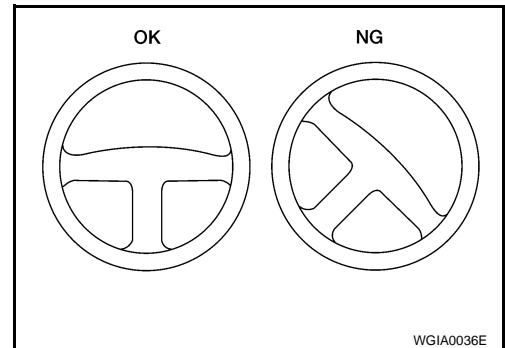

CHECKING STEERING WHEEL TURNING FORCE

1. Park vehicle on a level, dry surface and set parking brake.
2. Start engine.
3. Bring power steering fluid up to adequate operating temperature. Make sure the fluid temperature is approximately 60° – 80°C (140° – 176°F). Tires need to be inflated to normal pressure.
4. Check steering wheel turning force using a suitable spring gauge after turning steering wheel 360° from the neutral position.

Steering wheel turning force : 39 N (4 kg-f, 9 lb-f) or less

5. If steering wheel turning force is out of specification, check rack sliding force. Refer to [PS-14, "On-Vehicle Service"](#).
6. If rack sliding force is not within specifications, adjust rack sliding force. Refer to [PS-19, "Adjustment of Rack Sliding Force"](#).
7. If rack sliding force is OK, inspect steering column. Refer to [PS-12, "Inspection"](#).
8. If the steering column is OK, check the fluid pressure. Refer to [PS-21, "On-Vehicle Service"](#).

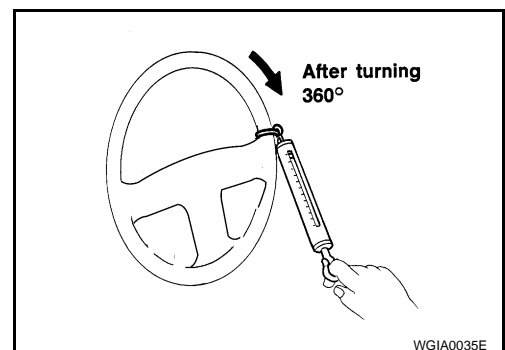

STEERING WHEEL

< SERVICE INFORMATION >

FRONT WHEEL TURNING ANGLE

1. Rotate steering wheel all the way right and left; measure turning angle. Refer to [FSU-19, "General Specification \(Front\)"](#).
2. If it is not within specifications, check rack stroke. Refer to [PS-25, "Steering Gear and Linkage"](#).

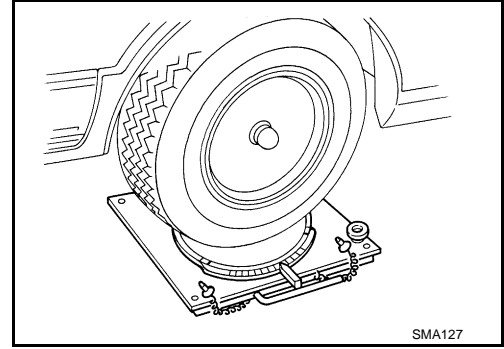

Removal and Installation

INFOID:000000001718391

REMOVAL

1. Set the front wheels in the straight-ahead position.
2. Remove the driver air bag module. Refer to [SRS-34, "Removal and Installation"](#).
3. Remove the steering wheel center nut.
4. Remove the steering wheel using Tools.

Tool numbers **A: KV481J0010 (J-1859-A)**
 B: KV481J0020 (J-42578)

CAUTION:

Do not tap or bump the steering wheel to remove.

- Place a piece of tape across the spiral cable so it will not be rotated out of position.
- Inspect the steering wheel near the puller holes for damage. If damaged, replace the steering wheel.
- Disconnect the horn connector.

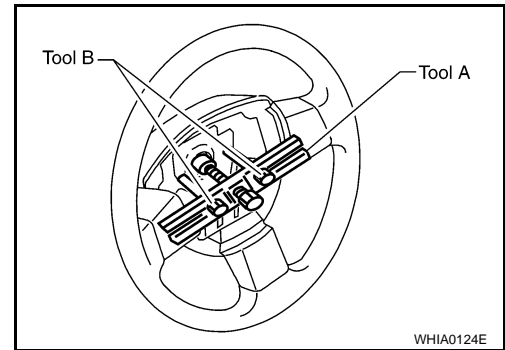

INSTALLATION

Installation is in the reverse order of removal.

- Align spiral cable correctly when installing steering wheel. Make sure that the spiral cable is in the neutral position. The neutral position is detected by turning left 2.6 revolutions from the right end position and ending with the knob at the top.

CAUTION:

- **The spiral cable may snap due to steering operation if the cable is installed in an improper position.**
 - **With the steering linkage disconnected, the cable may snap by turning the steering wheel beyond the limited number of turns. The spiral cable can be turned counterclockwise about 2.5 turns from the neutral position.**
- Tighten steering wheel center nut to specification. Refer to [PS-9, "Removal and Installation"](#).

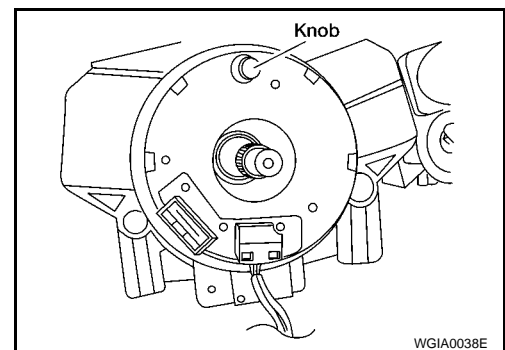

STEERING COLUMN

< SERVICE INFORMATION >

STEERING COLUMN

Removal and Installation

INFOID:000000001718392

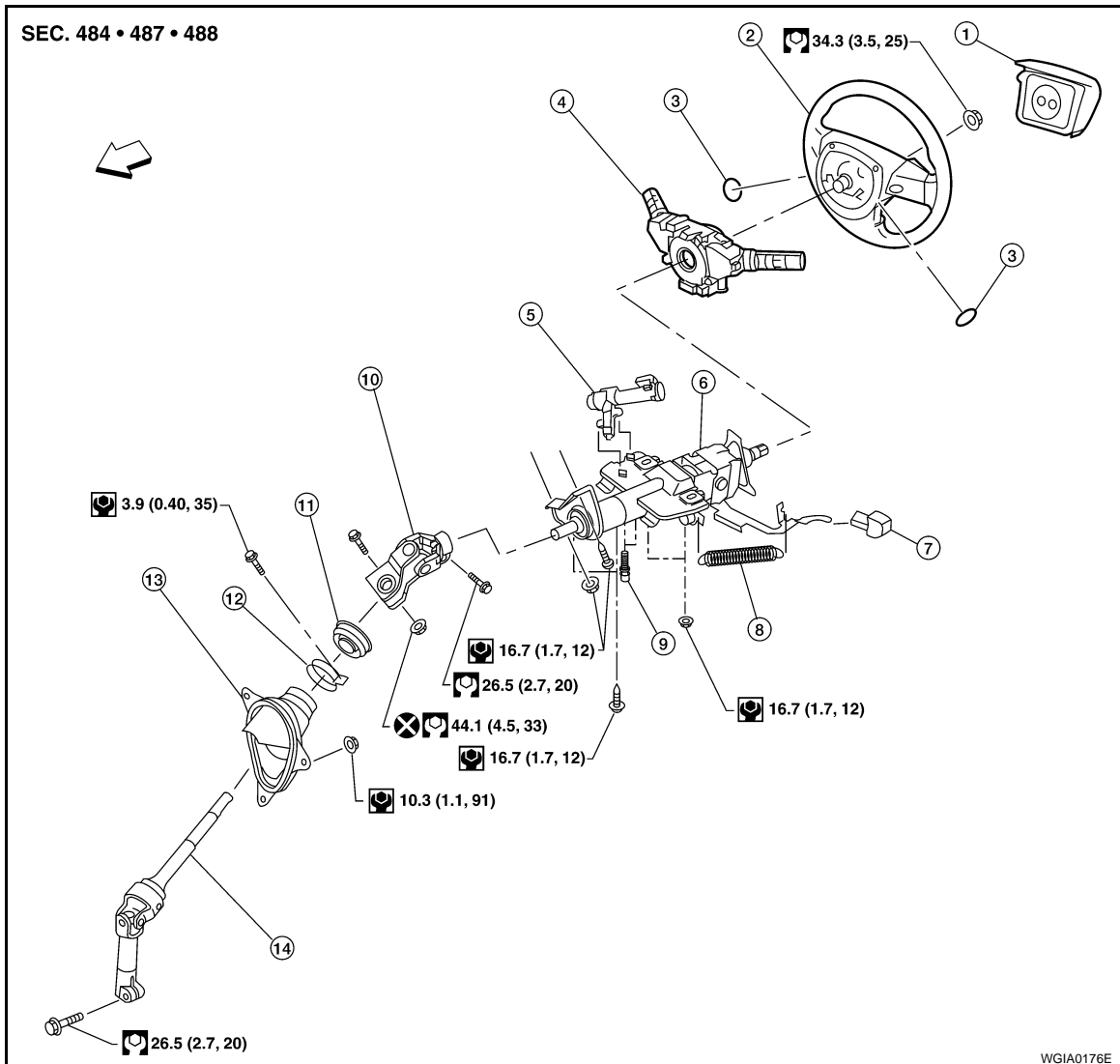

- | | | |
|--|---------------------|------------------------------|
| 1. Driver air bag module | 2. Steering wheel | 3. Steering wheel side cover |
| 4. Combination switch and spiral cable | 5. Ignition switch | 6. Steering column assembly |
| 7. Tilt lever knob | 8. Spring | 9. Self-shear bolt |
| 10. Upper joint | 11. Hole cover seal | 12. Clamp |
| 13. Hole cover | 14. Lower joint | ←: Front |

CAUTION:

- Care must be taken not to give axial impact to steering column assembly during removal and installation.
- Care must be taken not to move steering gear during removal of steering column assembly.

REMOVAL

1. Remove spiral cable from steering column assembly with combination switches attached. Refer to [SRS-36, "Removal and Installation"](#).
2. Remove steering column covers. Refer to [IP-12, "Steering Column Cover"](#).
3. Remove instrument driver lower panel. Refer to [IP-10, "Instrument Panel"](#).

STEERING COLUMN

< SERVICE INFORMATION >

4. Remove screws of knee protector, then remove knee protector from vehicle.

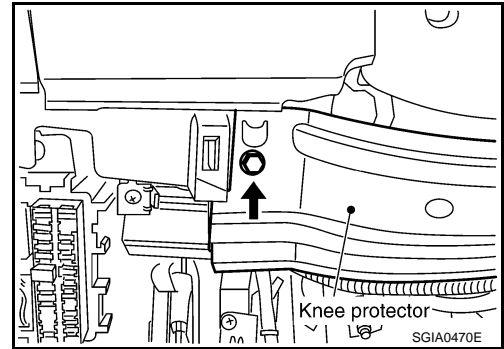

5. Remove lock nut and bolt, then separate lower joint from upper joint.

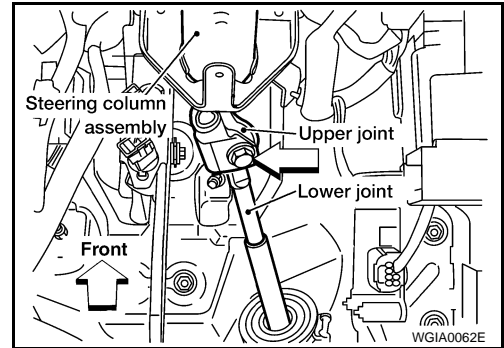

6. Remove nuts and bolt from steering member, remove steering column assembly from steering member.

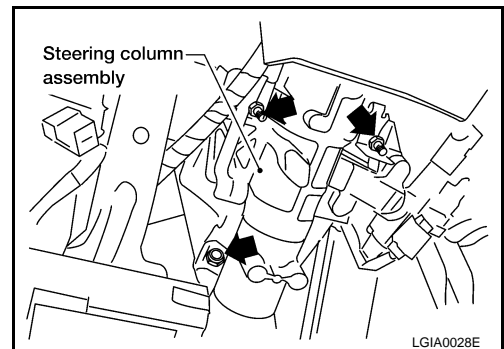

7. Remove hole cover seal and clamp.
8. Remove nuts, then remove hole cover from dash panel.
9. Raise vehicle, then remove bolt (lower side) of lower joint and remove lower joint from vehicle.

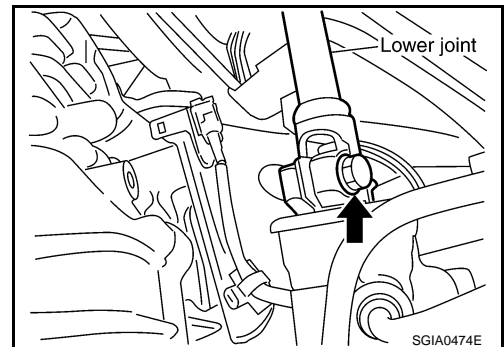

INSPECTION AFTER REMOVAL

- Check for damage to steering column jacket tube, if damage is found, replace steering column with new one.

STEERING COLUMN

< SERVICE INFORMATION >

- If vehicle has been in a collision, or if noise and rattles are heard during a turn, check the column length "L" as shown. If out of specification, replace the steering column as an assembly.

Steering column length "L" : 428 mm (16.85 in)

- Check for proper lubrication, apply grease as necessary.

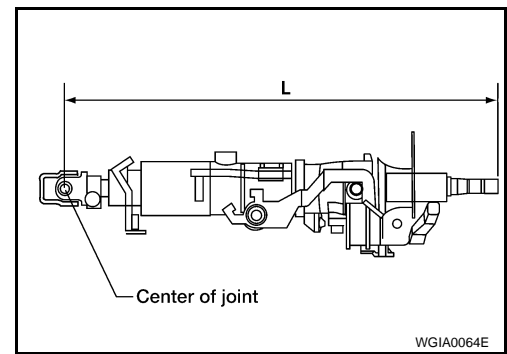

INSTALLATION

Installation is in the reverse order of removal.

- Tighten the nuts and bolts to the specified torque. Refer to "Removal and Installation".

NOTE:

Do not reuse non-reusable parts.

- When installing steering column to steering member, install nut from front side of vehicle.

CAUTION:

When installing the steering column, finger-tighten all of the lower bracket and joint retaining bolts; then tighten them to specification. Do not apply undue stress to the steering column.

NOTE:

Align slit of the coupling joint with projection on dust cover. Insert the joint until surface A contacts surface B.

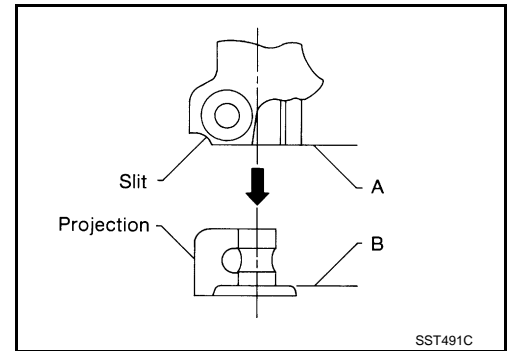

- After installation, turn steering wheel to make sure it moves smoothly. Ensure the number of turns are the same from the straight-forward position to left and right locks. Be sure that the steering wheel is in a neutral position when driving straight ahead.

INSPECTION AFTER INSTALLATION

- After installing steering column to vehicle, check tilt device and its operation range. Ranges of operation are shown.
- Check if steering wheel operation can turn to the end of the left and right stops smoothly.

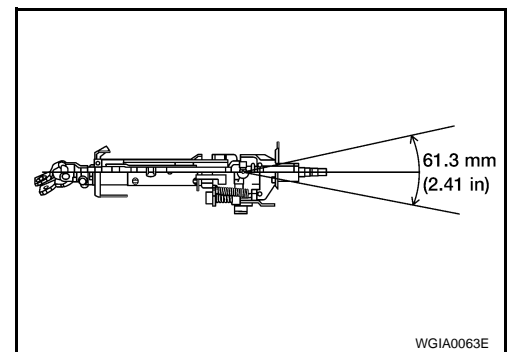

STEERING COLUMN

< SERVICE INFORMATION >

Disassembly and Assembly

INFOID:000000001718393

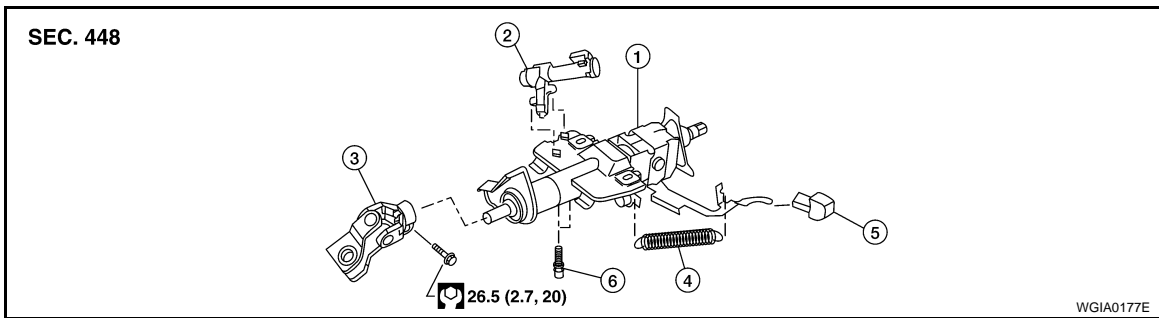

- | | | |
|-----------------------------|--------------------|--------------------|
| 1. Steering column assembly | 2. Ignition switch | 3. Upper joint |
| 4. Spring | 5. Tilt lever knob | 6. Self-shear bolt |

DISASSEMBLY

1. Remove spring from steering column assembly and tilt lever.
2. Remove bolt from upper joint, then remove upper joint from steering column assembly.

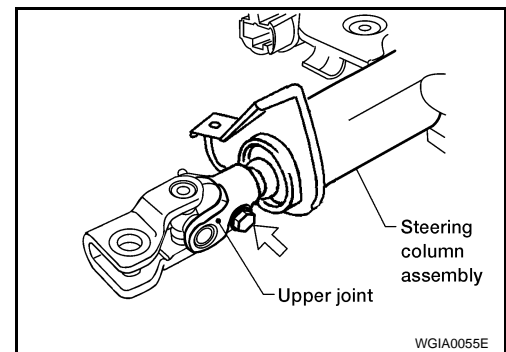

3. Remove ignition switch tamper resistant self-shear type screws with a drill or other suitable tool.

ASSEMBLY

Assembly is in the reverse order of disassembly.

- Tighten the nuts and bolts to the specified torque. Refer to "Disassembly and Assembly".
- Install new tamper resistant self-shear type screws as shown.

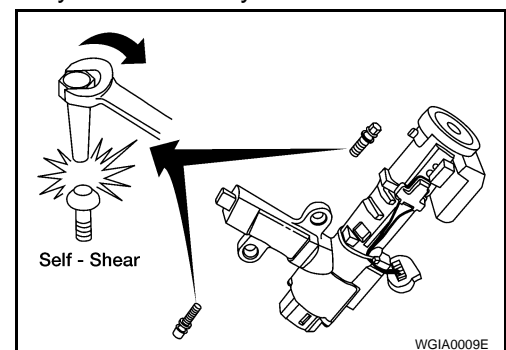

Inspection

INFOID:000000001718394

- When the steering wheel does not turn smoothly, check the steering column as follows:
 1. Check the column bearings for damage or unevenness. Lubricate with recommended multi-purpose grease. Replace the steering column as an assembly, if necessary.
 2. Check the column tube for deformation or breakage. Replace the steering column as an assembly, if necessary.

STEERING COLUMN

< SERVICE INFORMATION >

- If the vehicle has been involved in a collision, or if noise and rattles are heard during a turn, check the length “L” of the column. If out of specification, replace the steering column as an assembly.

Steering column length “L” : 428 mm (16.85 in)

- Check for proper lubrication, apply grease as necessary.
- Check for wear around the seal edges, replace as necessary.
- Check for corrosion or pitting around the seal sliding area.
- Replace the seal and shaft in case of seal edge wear or damage.

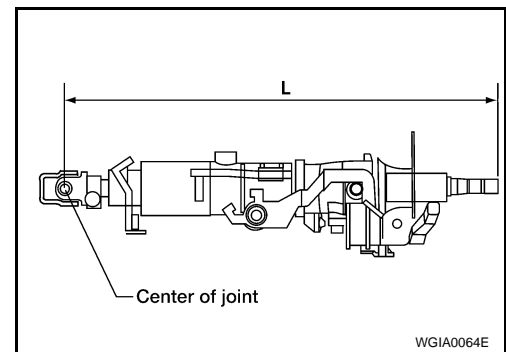

- After installing the steering column, check the tilt mechanism for proper operation.

Tilt mechanism range (manual tilt) : 3° per notch at 6 steps

CAUTION:

- Do not exert any load or impact in the axial direction immediately before or after column removal.
- After installation, check for smooth steering wheel rotation, without any catches or noise.
- Replace the column if it is depleted of grease, worn, damaged, or if any scratches or coating separation is present on the shaft seal area.
- The nut on the upper joint may not be reused.
- During lower joint detachment, insert a tool into the yoke groove to prevent gouging damage.

A
B
C
D
E
F
PS
H
I
J
K
L
M
N
O
P

POWER STEERING GEAR AND LINKAGE

< SERVICE INFORMATION >

POWER STEERING GEAR AND LINKAGE

On-Vehicle Service

INFOID:000000001718395

CHECKING STEERING GEAR

- Check gear housing and boots for looseness and damage.
- Check gear housing and boots for fluid leakage. Refer to [PS-6, "Checking Fluid Leakage"](#).
- Check connection with steering column for looseness.
- Prior to removing the steering gear from the vehicle, check rack sliding force. Refer to "Checking rack sliding force".
- If rack sliding force is not within specification, adjust rack sliding force. Refer to [PS-19, "Adjustment of Rack Sliding Force"](#).

CHECKING STEERING LINKAGE

- Check ball joint, and other component parts for looseness, wear, and damage.

CHECKING GEAR HOUSING MOVEMENT

1. Check the movement of steering gear housing during stationary steering on a dry paved surface.
 - Apply a force of 49 N (5 kg-f, 11 lb-f) to steering wheel to check the gear housing movement.
Turn off ignition key while checking.

Movement of gear housing : ± 2 mm (± 0.08 in) or less

2. If movement exceeds the limit, replace or repair as necessary.

CHECKING RACK SLIDING FORCE

1. Disconnect steering column lower joint and knuckle arms from the gear.
2. Start and run engine at idle to make sure steering fluid has reached normal operating temperature.
3. Using a suitable spring gauge, pull tie-rod slowly to move it from neutral position to ± 11.5 mm (± 0.453 in) at speed of 3.5 mm (0.138 in)/s. Check that rack sliding force is within specification. Refer to [PS-25, "Steering Gear and Linkage"](#).

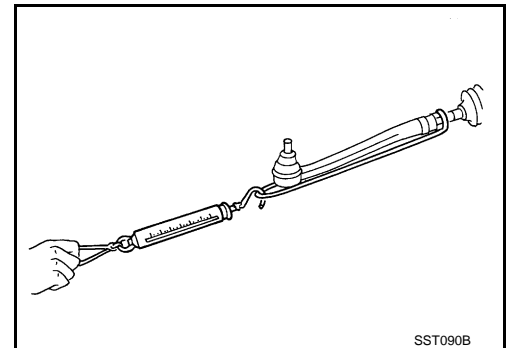

POWER STEERING GEAR AND LINKAGE

< SERVICE INFORMATION >

Removal and Installation

INFOID:000000001718396

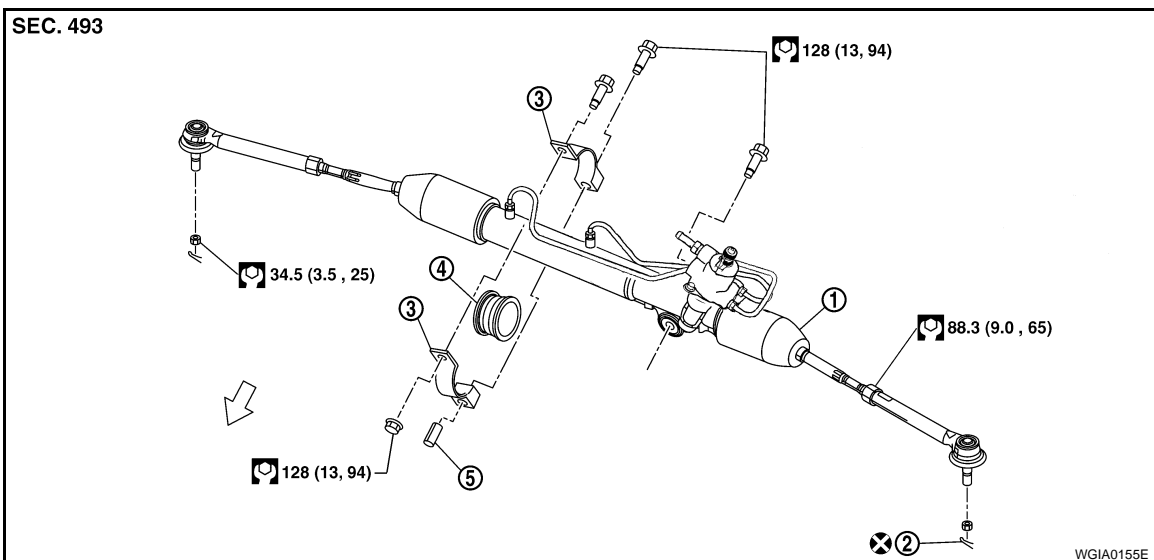

- | | | |
|---------------------------|---------------|----------------------------------|
| 1. Steering gear assembly | 2. Cotter pin | 3. Gear housing mounting bracket |
| 4. Gear housing insulator | 5. Sleeve | ← Front |

REMOVAL

CAUTION:

- The rotation of the driver air bag spiral cable is limited. If the steering gear must be removed, set the front wheels in the straight-ahead direction. Do not rotate the steering column while the steering gear is removed.
- Remove the steering wheel and spiral cable before removing the steering lower joint to avoid damaging the SRS spiral cable.

1. Remove the two front wheels and tires using power tool.
2. Remove cotter pins and nuts, then disconnect the outer tie-rods using Tool.

Tool number : HT72520000 (J-25730-A)

3. Disconnect the outer stabilizer bar ends from connecting rods using power tool. Refer to [FSU-12, "Removal and Installation"](#).

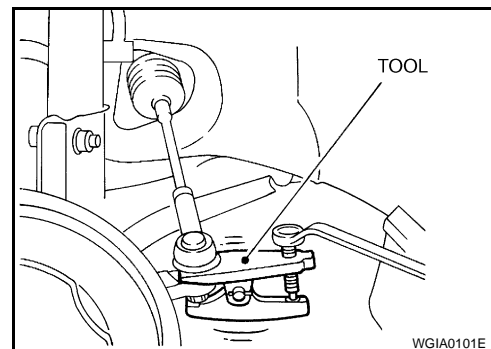

4. Remove the front stabilizer bar bracket rear bolts and loosen the front bolts. Refer to [FSU-12, "Removal and Installation"](#).

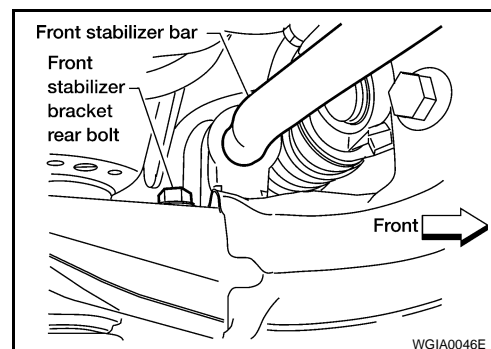

POWER STEERING GEAR AND LINKAGE

< SERVICE INFORMATION >

5. Remove the lower joint pinch bolt. Refer to [PS-9, "Removal and Installation"](#).

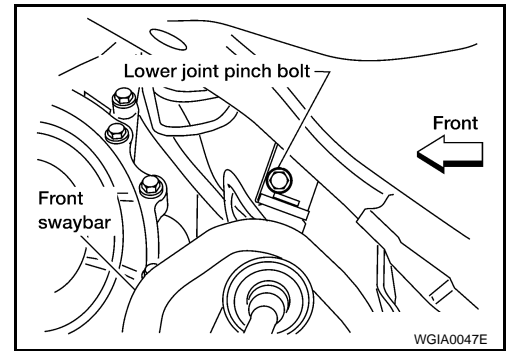

6. Drain the power steering fluid.
7. Disconnect the power steering high and low pressure lines from the steering gear.
8. Reposition the stabilizer bar up and out of the way.
9. Remove the two gear housing bolts using power tool. Refer to "Removal and Installation".
 - Do not remove the gear housing mounting bracket from the gear housing.
10. Remove the power steering gear and linkage assembly.

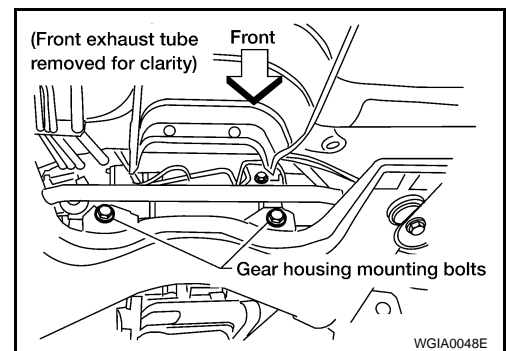

INSTALLATION

Installation is in the reverse order of removal.

NOTE:

Do not reuse non-reusable parts.

- Use the specified tightening torque when installing the high-pressure tube and low-pressure hose connections. Refer to [PS-24, "Removal and Installation"](#).

CAUTION:

Excessive tightening will damage threads of connection or O-ring.

- The O-ring in low-pressure hose connector is larger than that in high-pressure connector. Take care to install the proper O-ring.
- Initially, tighten nut on outer tie-rod socket and knuckle arm to specification. Then tighten further to align nut groove with first pin hole so that the cotter pin can be installed.

CAUTION:

Tightening torque must not exceed 49 N·m (5 kg·m, 36 ft·lb).

- Refill power steering system and bleed air after installation. Refer to [PS-6](#).

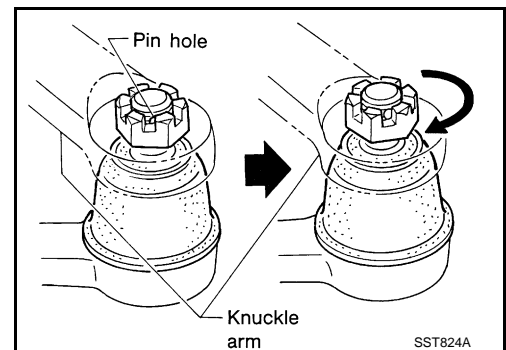

POWER STEERING GEAR AND LINKAGE

< SERVICE INFORMATION >

Disassembly and Assembly

INFOID:000000001718397

SEC. 492

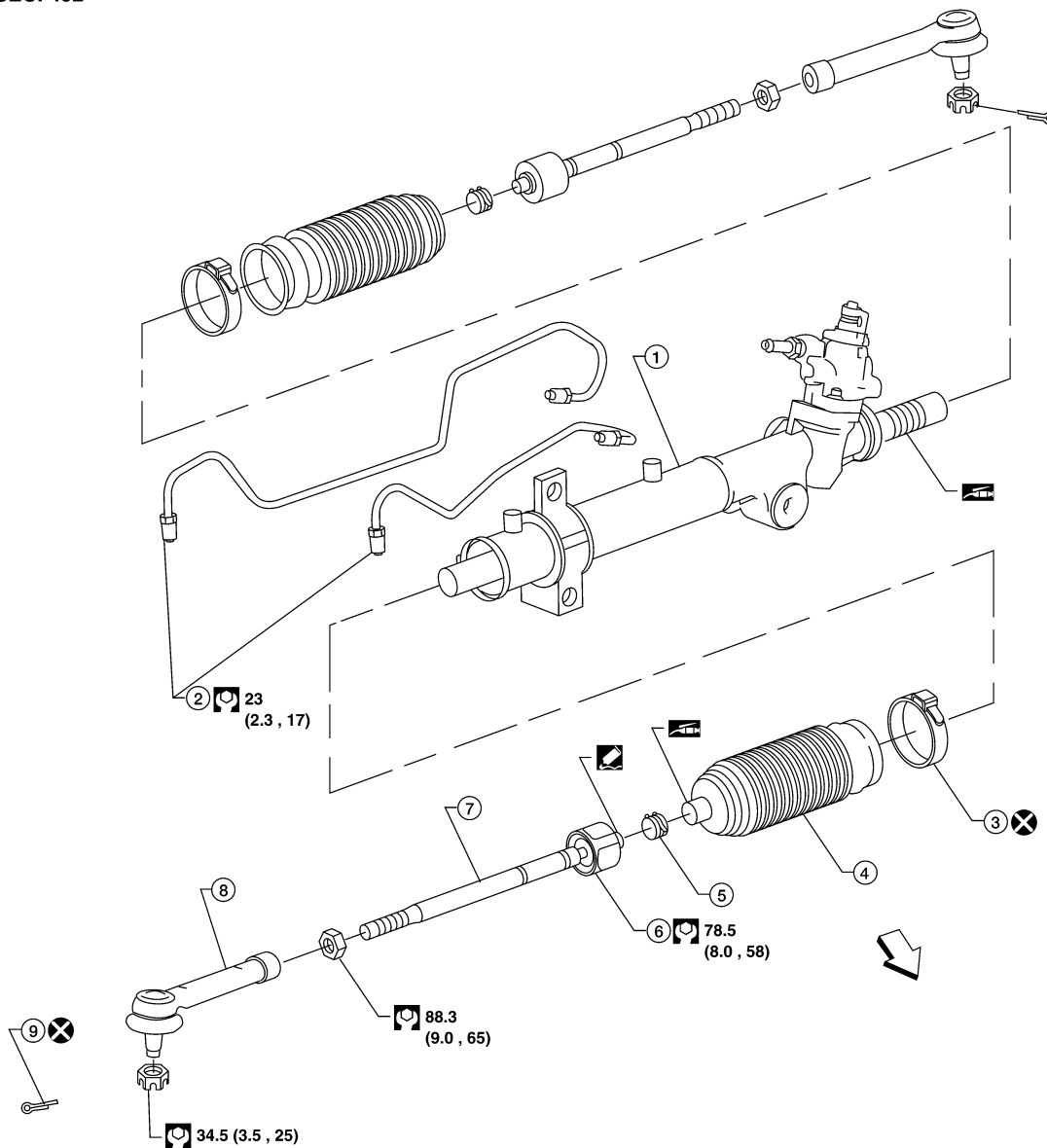

- | | | |
|--------------------------|-----------------------------|-------------------------|
| 1. Steering gear housing | 2. Gear housing fluid tubes | 3. Boot clamp |
| 4. Dust boot | 5. Boot band | 6. Tie-rod inner socket |
| 7. Inner tie-rod | 8. Outer tie-rod | 9. Cotter pin |
- ← Front

DISASSEMBLY

CAUTION:

- Use soft jaws when holding steering gear housing. Handle gear housing carefully, as it is made of aluminum. Do not grip cylinder in a vise.
- Do not disassemble steering gear housing. Replace as an assembly.

1. Remove the outer tie-rods.
2. Remove the boot clamps and boot bands
3. Remove the inner tie-rods and dust boots.

INSPECTION AFTER DISASSEMBLY

A
B
C
D
E
F
PS
H
I
J
K
L
M
N
O
P

POWER STEERING GEAR AND LINKAGE

< SERVICE INFORMATION >

Thoroughly clean all parts in cleaning solvent or Genuine NISSAN PSF or equivalent. Refer to [MA-11](#). Blow dry the parts with compressed air.

Boot

- Check condition of boot. If cracked, replace it.
- Check boots for accumulation of power steering fluid indicating a steering gear leak. If found, replace the steering gear as an assembly.

Gear

- Thoroughly examine steering gear. If damaged, cracked, leaking, or worn, replace it.

Inner and Outer Tie-rods

- Check ball joints for swinging force:
Outer tie-rod outer and inner ball joints swinging force "A". Refer to [PS-25, "Steering Gear and Linkage"](#).
- Check ball joint for rotating torque:
Outer tie-rod outer ball joint rotating torque "B". Refer to [PS-25, "Steering Gear and Linkage"](#).
- Check ball joints for axial end play:
Outer tie-rod outer and inner ball joints axial end play "C". Refer to [PS-25, "Steering Gear and Linkage"](#).
- Check condition of dust cover. If cracked, replace outer tie-rod.

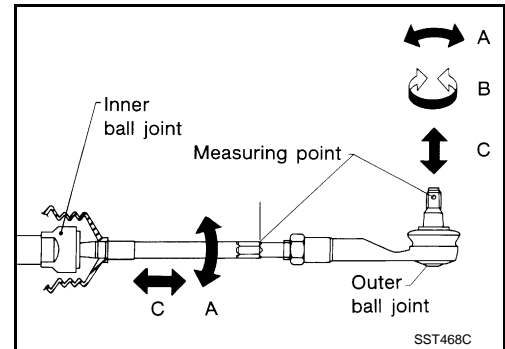

ASSEMBLY

1. Install the inner tie-rods.
2. Install the outer tie-rods to the specified length and tighten the outer tie-rod lock nut to specification. Refer to [PS-25, "Steering Gear and Linkage"](#).
Use Genuine High Temperature, High Strength Thread Locking Sealant (Red) or equivalent. Refer to [GI-42](#).

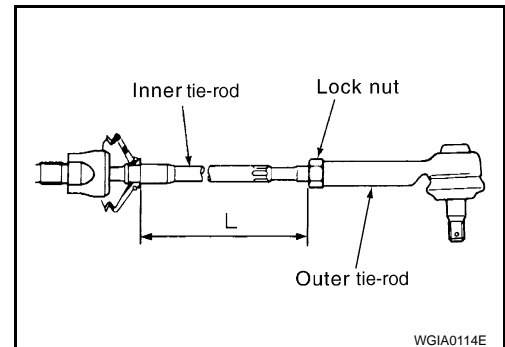

3. Measure rack stroke. Refer to [PS-25, "Steering Gear and Linkage"](#).

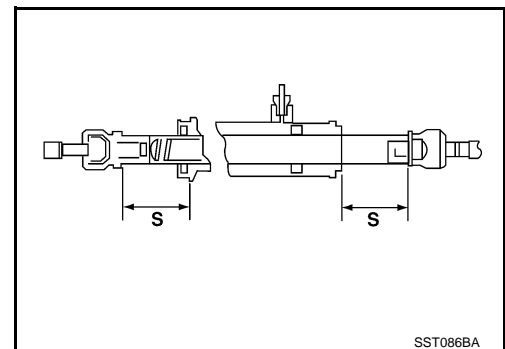

POWER STEERING GEAR AND LINKAGE

< SERVICE INFORMATION >

4. Before installing the dust boot, coat the contact surfaces between the boot and the inner tie-rod with grease.

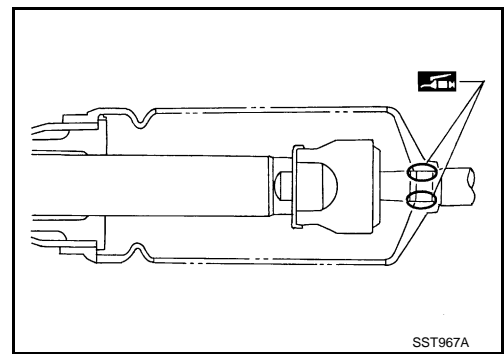

5. Install the boot clamps and boot bands securely.

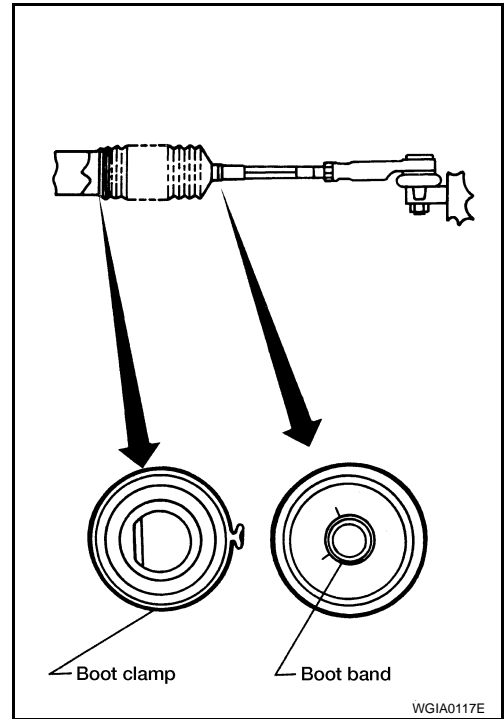

Adjustment of Rack Sliding Force

INFOID:000000001718398

DECREASE

Decrease rack sliding force as follows:

1. Loosen adjusting screw two rotations counterclockwise.

CAUTION:

- Do not remove adjusting screw.
- Steering gear must be replaced if adjusting screw is removed or loosened more than two rotations.

2. Tighten adjusting screw in 40° - 60° increments until rack sliding force is within specification. Refer to [PS-25, "Steering Gear and Linkage"](#).

NOTE:

Steering gear must be replaced if adjusting screw rotation torque is less than 5.0 N·m (0.9 kg·m, 44 in·lb).

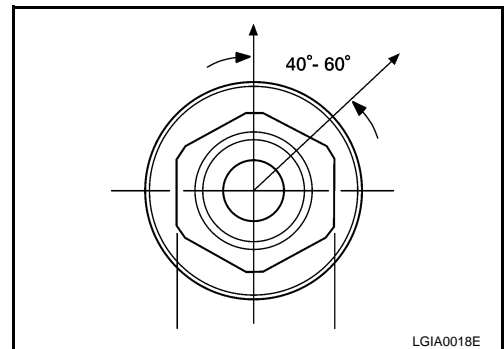

3. Verify rack sliding force. Refer to [PS-14, "On-Vehicle Service"](#).
4. If rack sliding force is out of specification adjust rack sliding force again.
5. If rack sliding force cannot be adjusted within specification replace steering gear.

POWER STEERING GEAR AND LINKAGE

< SERVICE INFORMATION >

INCREASE

Increase rack sliding force as follows:

1. Tighten adjusting screw until it is flush with housing surface.

CAUTION:

- Do not remove adjusting screw.
- Steering gear must be replaced if adjusting screw is removed or loosened more than two rotations.

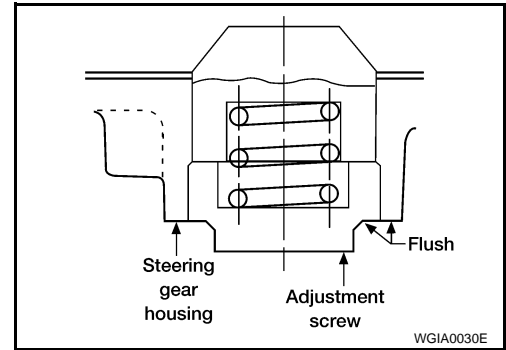

2. Loosen adjusting screw in 40° - 60° increments until rack sliding force is within specification. Refer to [PS-25. "Steering Gear and Linkage"](#).

NOTE:

Steering gear must be replaced if adjusting screw rotation torque is less than 5.0 N·m (0.9 kg-m, 44 in-lb).

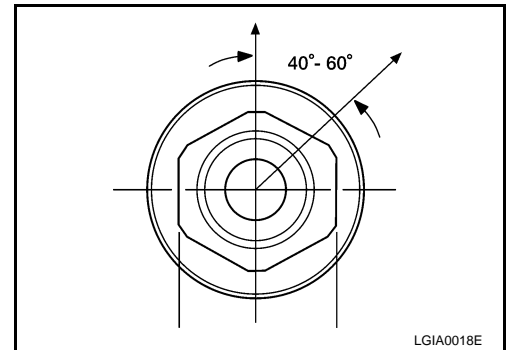

3. Verify rack sliding force. Refer to [PS-14. "On-Vehicle Service"](#).
4. If rack sliding force is out of specification adjust rack sliding force again.
5. If rack sliding force cannot be adjusted within specification replace steering gear.

POWER STEERING OIL PUMP

< SERVICE INFORMATION >

POWER STEERING OIL PUMP

On-Vehicle Service

INFOID:000000001718399

CHECKING HYDRAULIC SYSTEM

Before starting, check belt tension, driving pulley and tire pressure.

1. Set Tool. Open shut-off valve. Then bleed air. Refer to [PS-6, "Bleeding Hydraulic System"](#).

Tool numbers : KV48103500 (J-26357 and J-26357-10),
KV48102500 (J-33914)

2. Run engine at idle speed or 1,000 rpm.
Make sure temperature of fluid in tank rises to 60° – 80°C (140° – 176°F).

WARNING:

Warm up engine with shut-off valve fully opened. If engine is started with shut-off valve closed, fluid pressure in oil pump increases to maximum. This will raise oil temperature abnormally.

3. Check pressure with steering wheel fully turned to left and right positions with engine idling at 1,000 rpm.

CAUTION:

Do not hold the steering wheel in a locked position for more than 15 seconds.

Oil pump maximum standard pressure : 8,800 kPa (89.76 kg/cm², 1,276 psi)

- If pressure reaches maximum operating pressure, system is OK.
- If pressure increases above maximum operating pressure, check power steering pump flow control valve. Refer to [PS-25, "Power Steering"](#).

4. If power steering pressure is below the maximum operating pressure, slowly close shut-off valve and check pressure again.

CAUTION:

Do not close shut-off valve for more than 15 seconds.

- If pressure increases to maximum operating pressure, gear is damaged. Refer to [PS-15, "Removal and Installation"](#).
- If pressure remains below maximum operating pressure, pump is damaged. Refer to [PS-21, "Removal and Installation"](#).

5. After checking hydraulic system, remove Tool and add fluid as necessary. Then completely bleed air out of system. Refer to [PS-6, "Bleeding Hydraulic System"](#).

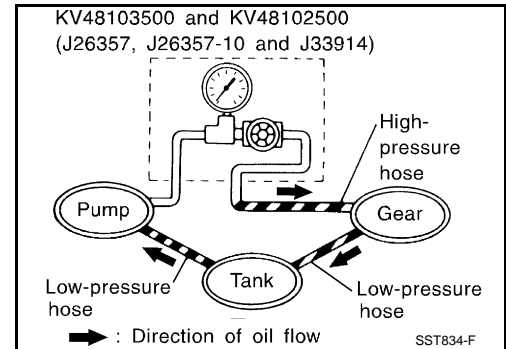

Removal and Installation

INFOID:000000001718400

REMOVAL

POWER STEERING OIL PUMP

< SERVICE INFORMATION >

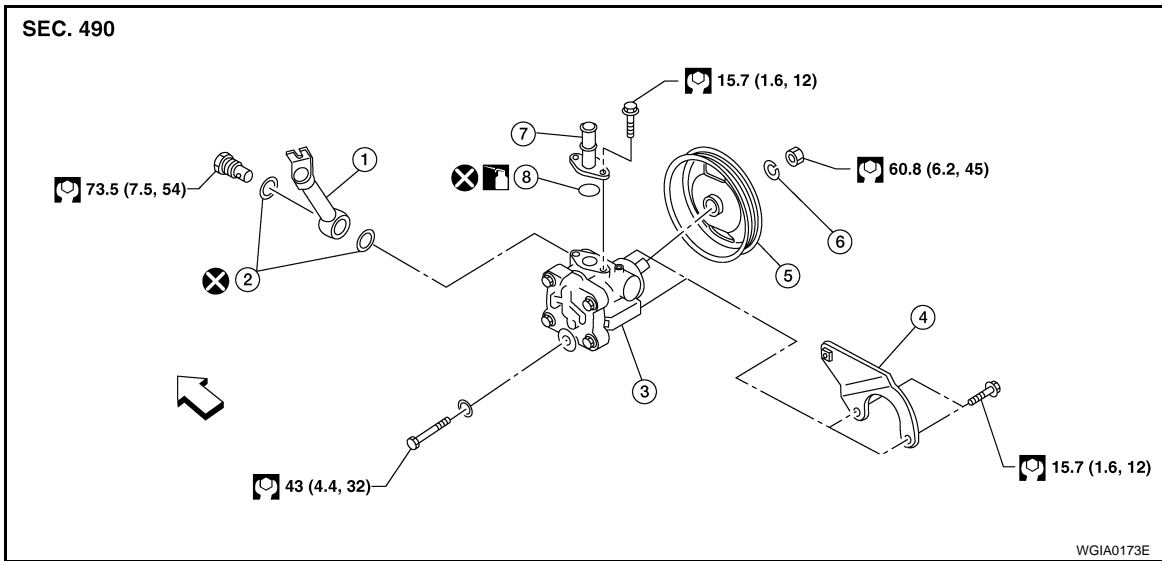

- | | | |
|-----------------|------------|----------------------------|
| 1. Joint | 2. Washers | 3. Power steering oil pump |
| 4. Bracket | 5. Pulley | 6. Spring washer |
| 7. Suction pipe | 8. O-ring | ← Front |

1. Remove wheel and tire using power tool.
2. Remove side splash guard.
3. Remove heat insulator.
4. Loosen adjustment screw and oil pump bolt, then remove belt.
5. Drain power steering fluid.
6. Remove power steering oil pump union bolt and hose.
7. Remove power steering oil pump bracket bolts.
8. Remove power steering oil pump.

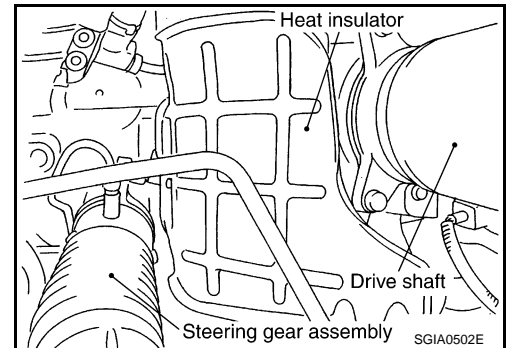

INSTALLATION

Installation is in the reverse order of removal.

- Tighten component connections to specification. Refer to [PS-23, "Disassembly and Assembly"](#).
- Adjust belt tension. Refer to [EM-12, "Checking Drive Belts"](#).
- Refill power steering system and bleed air after installation. Refer to [PS-6](#).

POWER STEERING OIL PUMP

< SERVICE INFORMATION >

Disassembly and Assembly

INFOID:000000001718401

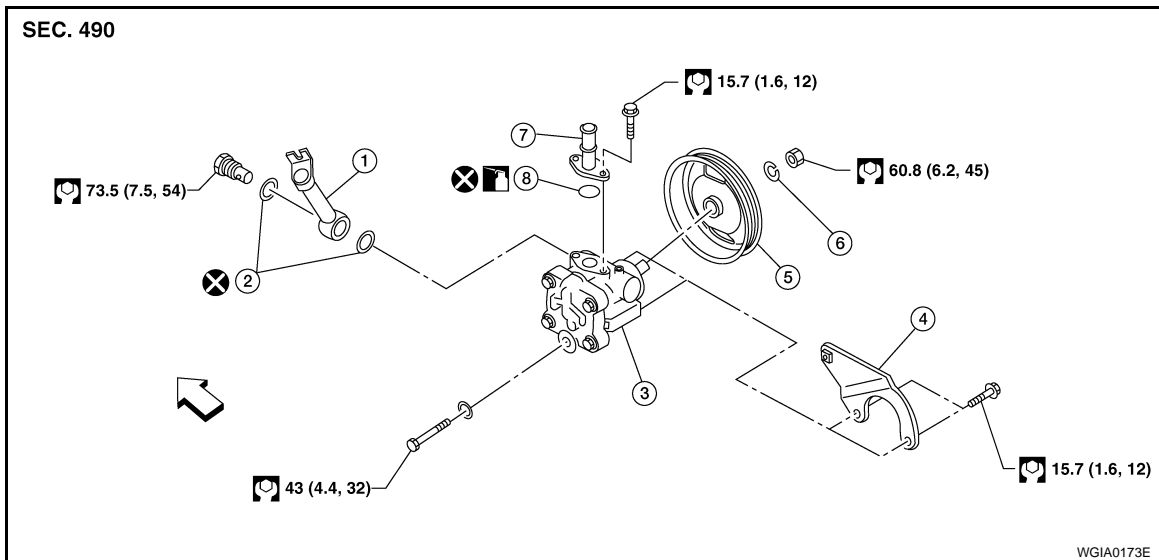

- | | | |
|-----------------|------------|----------------------------|
| 1. Joint | 2. Washers | 3. Power steering oil pump |
| 4. Bracket | 5. Pulley | 6. Spring washer |
| 7. Suction pipe | 8. O-ring | ← Front |

INSPECTION BEFORE DISASSEMBLY

If the following conditions are found, replace as necessary.

- Oil leakage from oil pump
- Deformed or damaged pulley
- Poor performance

DISASSEMBLY

CAUTION:

Do not disassemble pump body. Replace as an assembly.

NOTE:

Mount the oil pump in a soft jawed vise as necessary.

1. Remove nut, washer and pulley from drive shaft.
2. Remove the following from the power steering oil pump:
 - Union bolt, washers, and joint.
 - Bolts and bracket.
 - Bolts and suction pipe.
 - Suction pipe O-ring.

ASSEMBLY

NOTE:

Mount oil pump in soft jawed vise as required.

1. Check if drive shaft assembly turns smoothly.
2. Install bracket to power steering oil pump, and tighten the two bracket bolts to specification.
3. Install pulley to drive shaft assembly, then tighten lock nut to specification.
4. Install washers and joint to power steering oil pump, then tighten union bolt to specification.

NOTE:

Do not reuse washers.

5. Apply a coat of NISSAN PSF or equivalent to O-ring and install O-ring to suction pipe. Refer to [MA-11](#).
6. Install suction pipe to power steering oil pump and tighten bolts to the specification.

HYDRAULIC LINE

< SERVICE INFORMATION >

HYDRAULIC LINE

Removal and Installation

INFOID:000000001718402

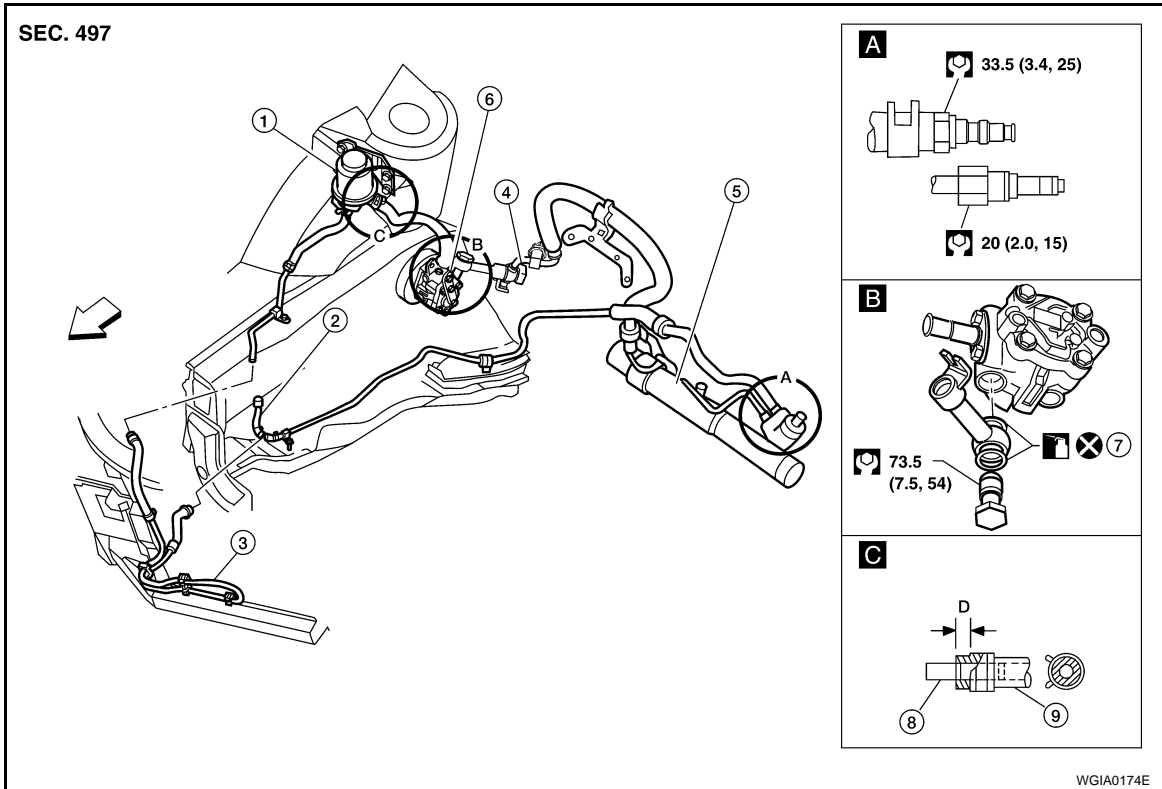

- | | | |
|-----------------------------------|------------------------|----------------------------|
| 1. Power steering fluid reservoir | 2. Return line | 3. Power steering cooler |
| 4. Power steering pressure switch | 5. Power steering gear | 6. Power steering oil pump |
| 7. Washers | 8. Tube | 9. Hose |
| D 3 - 8 mm (0.1 - 0.3 in) | ← Front | |

REMOVAL

Refer to the illustration for hydraulic tube and hose routing. Remove any components necessary to access the lines.

CAUTION:

Be careful not to kink or bend the tubes.

INSTALLATION

Installation is in the reverse order of removal.

- Refer to [PS-14](#) and [PS-21](#) for tightening torques.

NOTE:

Do not reuse non-reusable parts.

- Ensure that hose is properly installed on tube to specification.

CAUTION:

Do not apply power steering fluid to surface between tube and hose.

- To install the eye joint on the power steering pump, align the projection of the eye joint into the notch of the power steering pump. Make sure the eye joint is properly installed on the power steering pump, then tighten the eye bolt to specification.
- Connect the harness connector into the power steering pressure switch securely.

SERVICE DATA AND SPECIFICATIONS (SDS)

< SERVICE INFORMATION >

SERVICE DATA AND SPECIFICATIONS (SDS)

General Specification

INFOID:000000001718403

Steering model	Power steering
Steering gear type	PR26AD
Steering overall gear ratio	17.1:1
Turns of steering wheel (lock to lock)	3.0
Steering column type	Collapsible, manual tilt

Steering Wheel

INFOID:000000001718404

Unit: mm (in)

Steering wheel axial play	0 (0)
Steering wheel play	35 (1.38) or less
Movement of gear housing	± 2 (± 0.08) or less

Steering Column

INFOID:000000001718405

Unit: mm (in)

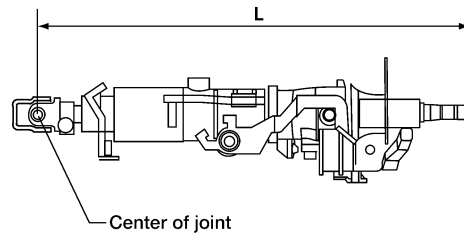

WGIA0064E

Applied model	All
Steering column length "L"	428 (16.85)

Power Steering

INFOID:000000001718406

Applied model	All
Steering gear type	PR26AD
Pump type	F40
Steering wheel turning force (Measured at one full turn from the neutral position)	39 N (4 kg-f, 9 lb-f) or less
Fluid capacity (approximate)	1.0 ℓ (2 1/8 US pt, 1 3/4 Imp pt)
Oil pump maximum pressure	8,800 kPa (89.76 kg/cm ² , 1,276 psi)

Steering Gear and Linkage

INFOID:000000001718407

Applied model	All
Steering gear type	PR26AD

SERVICE DATA AND SPECIFICATIONS (SDS)

< SERVICE INFORMATION >

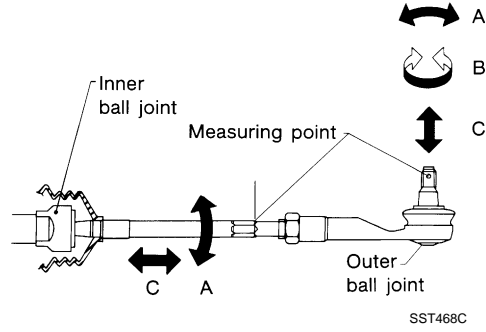

Tie-rod outer ball joint	Swinging force at cotter pin hole "A"	6.47 - 64.63 N (0.66 - 6.59 kg-f, 1.46 - 14.53 lb-f)
	Rotating torque "B"	0.29 - 2.94 N·m (3.0 - 30.0 kg-cm, 2.6 - 26.0 in-lb)
	Axial end play "C"	0.4 mm (0.016 in) or less
Tie-rod inner ball joint	Swinging force* "A" * Measuring point: 172 mm (6.77 in)	5.69 - 45.60 N (0.58 - 4.65 kg-f, 1.28 - 10.25 lb-f)
	Axial end play "C"	0.2 mm (0.008 in) or less

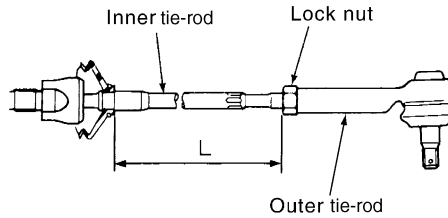

Tie-rod standard length "L"		204.7 mm (8.059 in)	
Rack sliding force Under normal operating oil pressure	Range within ± 11.5 mm (± 0.453 in) from the neutral position at rack speed of 3.5 mm (0.138 in)/s	Average force	235 - 314 N (24 - 32 kg-f, 53 - 71 lb-f)*
		Minimum force	186 N (19 kg-f, 41.8 lb-f)

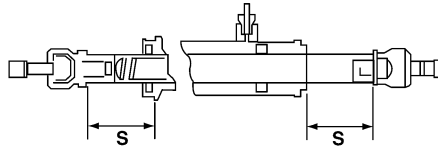

Rack stroke "S"	73.5 mm (2.89 in)
-----------------	-------------------

*: Target force of 279.5 N (kg-f, lb-f)