

SECTION **EX**
EXHAUST SYSTEM



CONTENTS

| | | | | |
|--|---|--------------------------------|---|---|
| SERVICE INFORMATION | 2 | Special Service Tool | 3 | F |
| PRECAUTIONS | 2 | Commercial Service Tool | 3 | |
| Precaution for Supplemental Restraint System (SRS) "AIR BAG" and "SEAT BELT PRE-TEN- SIONER" | 2 | EXHAUST SYSTEM | 4 | G |
| PREPARATION | 3 | Checking Exhaust System | 4 | |
| | | Exploded View | 5 | |
| | | Removal and Installation | 6 | H |

A
C
D
E
F
G
H
I
J
K
L
M
N
O
P

PRECAUTIONS

< SERVICE INFORMATION >

SERVICE INFORMATION

PRECAUTIONS

Precaution for Supplemental Restraint System (SRS) "AIR BAG" and "SEAT BELT PRE-TENSIONER"

INFOID:000000004278812

The Supplemental Restraint System such as "AIR BAG" and "SEAT BELT PRE-TENSIONER", used along with a front seat belt, helps to reduce the risk or severity of injury to the driver and front passenger for certain types of collision. This system includes seat belt switch inputs and dual stage front air bag modules. The SRS system uses the seat belt switches to determine the front air bag deployment, and may only deploy one front air bag, depending on the severity of a collision and whether the front occupants are belted or unbelted. Information necessary to service the system safely is included in the SRS and SB section of this Service Manual.

WARNING:

- **To avoid rendering the SRS inoperative, which could increase the risk of personal injury or death in the event of a collision which would result in air bag inflation, all maintenance must be performed by an authorized NISSAN/INFINITI dealer.**
- **Improper maintenance, including incorrect removal and installation of the SRS, can lead to personal injury caused by unintentional activation of the system. For removal of Spiral Cable and Air Bag Module, see the SRS section.**
- **Do not use electrical test equipment on any circuit related to the SRS unless instructed to in this Service Manual. SRS wiring harnesses can be identified by yellow and/or orange harnesses or harness connectors.**

PREPARATION

< SERVICE INFORMATION >

PREPARATION

Special Service Tool

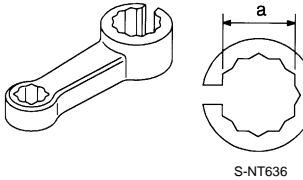

INFOID:000000004278813

The actual shapes of Kent-Moore tools may differ from those of special service tools illustrated here.

| Tool number (Kent-Moore No.) Tool name | Description |
|---|---|
| KV10114400 (J-38365) Heated oxygen sensor wrench  | Loosening or tightening heated oxygen sensors: a: 22 mm (0.87 in) |

Commercial Service Tool

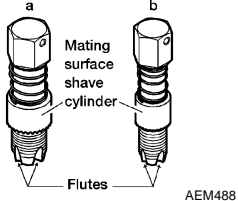
INFOID:000000004278814

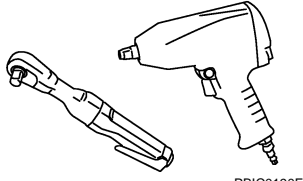
| (Kent-Moore No.) Tool name | Description |
|--|--|
| (J-43897-18) (J-43897-12) Oxygen sensor thread cleaner  | Reconditioning the exhaust system threads before installing a new heated oxygen sensor (Use with anti-seize lubricant shown below): a: J-43897-18 (18 mm dia , 0.71 in) for zirconia heated oxygen sensor. b: J-43897-12 (12 mm dia., 0.49 in) for titania heated oxygen sensor. |
| Anti-seize lubricant (Permatex 133AR or equivalent meeting MIL specification MIL-A-907)  | Lubricating oxygen sensor thread cleaning tool when reconditioning exhaust system threads. |
| Power tool  | Loosening nuts and bolts. |

EXHAUST SYSTEM

< SERVICE INFORMATION >

EXHAUST SYSTEM

Checking Exhaust System

INFOID:000000004278815

Check the exhaust pipes, muffler, and mounting components for incorrect attachment, leaks, cracks, damage, or deterioration.

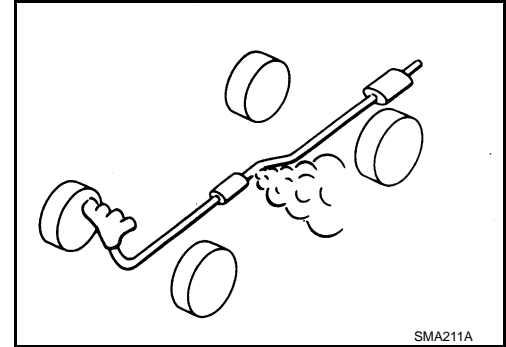

SMA211A

EXHAUST SYSTEM

< SERVICE INFORMATION >

Exploded View

INFOID:000000004684919

SEC. 200

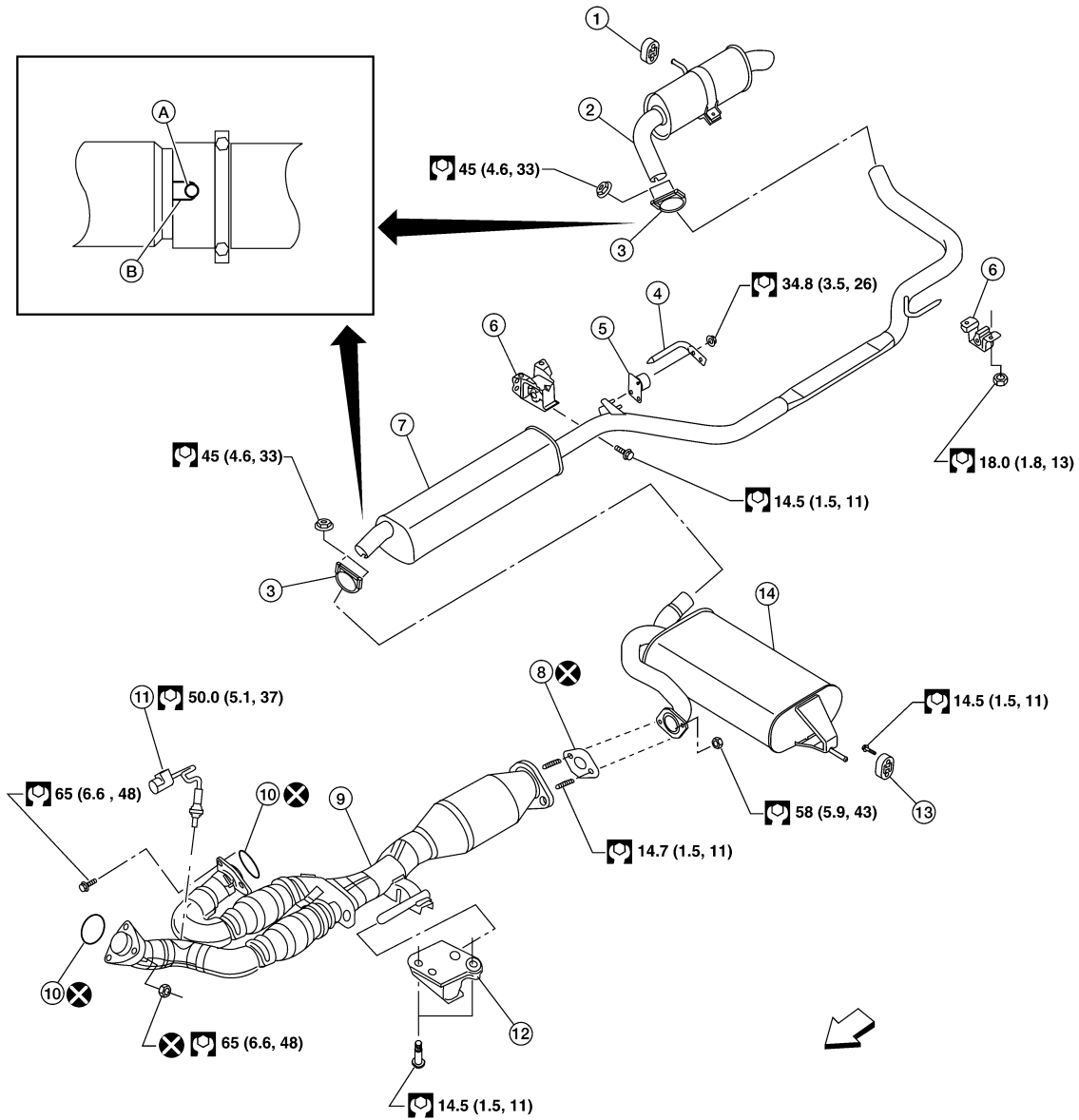

- | | | |
|-------------------------------|-------------------------------------|---------------------------------------|
| 1. Rear muffler hanger | 2. Rear muffler | 3. U clamp |
| 4. Center exhaust tube hanger | 5. Dynamic damper | 6. Center exhaust tube hanger bracket |
| 7. Center exhaust tube | 8. Gasket | 9. Front exhaust tube |
| 10. Ring gasket | 11. Heated oxygen sensor 2 (bank 2) | 12. Front exhaust tube hanger bracket |
| 13. Main muffler hanger | 14. Main muffler | A. Button |
| B. Slot | ← Vehicle front | |

AWBIA0753GB

EXHAUST SYSTEM

< SERVICE INFORMATION >

Removal and Installation

INFOID:000000004684929

WARNING:

- Perform the operation with the exhaust system fully cooled. The system will be hot just after the engine stops.
- Be careful not to cut your hand on the heat insulator edge.

CAUTION:

- Be sure to use genuine exhaust system parts or equivalents which are specially designed for heat resistance, corrosion resistance, and shape.

REMOVAL

Remove exhaust system components using power tool.

- Remove heated oxygen sensor using Tool as needed.

Tool number : KV10114400 (J-38365)

INSTALLATION

Installation is in the reverse order of removal.

CAUTION:

- Always replace exhaust gaskets with new ones when reassembling.
- Before installing a new heated oxygen sensor, clean and lube the exhaust tube threads using suitable tool.

Oxygen sensor thread cleaner : — (J-43897-18)

Oxygen sensor thread cleaner : — (J-43897-12)

- Discard any heated oxygen sensor which has been dropped from a height of more than 0.5 m (19.7 in) onto a hard surface such as a concrete floor; install a new one.
- Do not over-tighten the heated oxygen sensor. Doing so may damage the heated oxygen sensor, resulting in the MIL coming on.
- If any mounting insulator is badly deformed, repair or replace it. If deposits such as mud pile up on the mounting insulators, clean and inspect them.
- Temporarily tighten the nuts on the exhaust manifold side and the bolts on the vehicle side. Check each part for interference with other components, and then tighten the nuts and bolts to specification.

INSPECTION AFTER INSTALLATION

- With the engine running, check exhaust tube joints for gas leakage and unusual noises.
- Check to ensure that mounting brackets and mounting rubbers are installed properly and free from undue stress. Improper installation could result in excessive noise and vibration.