

SECTION **FAX**
FRONT AXLE

A
B
C

FAX

CONTENTS

E

PRECAUTION	2	FRONT DRIVE SHAFT BOOT	11	F
PRECAUTIONS	2	Exploded View	11	
Precaution for Supplemental Restraint System (SRS) "AIR BAG" and "SEAT BELT PRE-TENSIONER"	2	WHEEL SIDE	12	G
Precautions for Drive Shaft	2	WHEEL SIDE : Removal and Installation	12	
PREPARATION	3	TRANSAXLE SIDE	15	H
PREPARATION	3	TRANSAXLE SIDE : Removal and Installation	15	
Special Service Tool	3	Inspection	15	
Commercial Service Tools	4	FRONT DRIVE SHAFT	16	I
SYMPTOM DIAGNOSIS	5	Exploded View	16	
NOISE, VIBRATION AND HARSHNESS (NVH) TROUBLESHOOTING	5	LEFT SIDE	17	J
NVH Troubleshooting Chart	5	LEFT SIDE : Removal and Installation	17	
PERIODIC MAINTENANCE	6	RIGHT SIDE	18	K
FRONT WHEEL HUB AND KNUCKLE	6	RIGHT SIDE : Removal and Installation	18	
Inspection	6	WHEEL SIDE	20	L
FRONT DRIVE SHAFT	7	WHEEL SIDE : Disassembly and Assembly	21	
Inspection	7	TRANSAXLE SIDE	23	M
REMOVAL AND INSTALLATION	8	TRANSAXLE SIDE : Disassembly and Assembly (Left Side)	23	
FRONT WHEEL HUB AND KNUCKLE	8	TRANSAXLE SIDE : Disassembly and Assembly (Right Side)	25	
Exploded View	8	Inspection	29	N
Removal and Installation	8	SERVICE DATA AND SPECIFICATIONS (SDS)	30	O
Inspection	10	SERVICE DATA AND SPECIFICATIONS (SDS)	30	
		Wheel Bearing	30	P
		Drive Shaft	30	

PRECAUTIONS

< PRECAUTION >

PRECAUTION

PRECAUTIONS

Precaution for Supplemental Restraint System (SRS) "AIR BAG" and "SEAT BELT PRE-TENSIONER"

INFOID:000000007136372

The Supplemental Restraint System such as "AIR BAG" and "SEAT BELT PRE-TENSIONER", used along with a front seat belt, helps to reduce the risk or severity of injury to the driver and front passenger for certain types of collision. This system includes seat belt switch inputs and dual stage front air bag modules. The SRS system uses the seat belt switches to determine the front air bag deployment, and may only deploy one front air bag, depending on the severity of a collision and whether the front occupants are belted or unbelted. Information necessary to service the system safely is included in the "SRS AIR BAG" and "SEAT BELT" of this Service Manual.

WARNING:

Always observe the following items for preventing accidental activation.

- **To avoid rendering the SRS inoperative, which could increase the risk of personal injury or death in the event of a collision that would result in air bag inflation, all maintenance must be performed by an authorized NISSAN/INFINITI dealer.**
- **Improper maintenance, including incorrect removal and installation of the SRS, can lead to personal injury caused by unintentional activation of the system. For removal of Spiral Cable and Air Bag Module, see "SRS AIR BAG".**
- **Never use electrical test equipment on any circuit related to the SRS unless instructed to in this Service Manual. SRS wiring harnesses can be identified by yellow and/or orange harnesses or harness connectors.**

PRECAUTIONS WHEN USING POWER TOOLS (AIR OR ELECTRIC) AND HAMMERS

WARNING:

Always observe the following items for preventing accidental activation.

- **When working near the Air Bag Diagnosis Sensor Unit or other Air Bag System sensors with the ignition ON or engine running, never use air or electric power tools or strike near the sensor(s) with a hammer. Heavy vibration could activate the sensor(s) and deploy the air bag(s), possibly causing serious injury.**
- **When using air or electric power tools or hammers, always switch the ignition OFF, disconnect the battery, and wait at least 3 minutes before performing any service.**

Precautions for Drive Shaft

INFOID:000000007050904

- **Observe the following precautions when disassembling and assembling drive shaft.**
 - Never disassemble joint sub-assembly because it is non-overhaul parts.
 - Perform work in a location which is as dust-free as possible.
 - Clean the parts, before disassembling and assembling.
 - Prevent the entry of foreign objects during disassembly of the service location.
 - Reassemble disassembled parts carefully in the correct order. If work is interrupted, a clean cover must be placed over parts.
 - Use paper waste. Fabric shop cloths must not be used because of the danger of lint adhering to parts.
 - Clean disassembled parts (except for rubber parts) with kerosene which shall be removed by blowing with air or wiping with paper waste.

PREPARATION

< PREPARATION >



PREPARATION

PREPARATION

Special Service Tool

INFOID:000000007050905

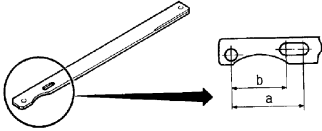
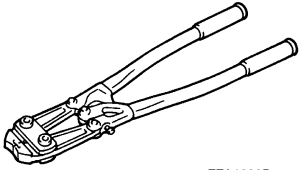
The actual shapes of Kent-Moore tools may differ from those of special service tools illustrated here.

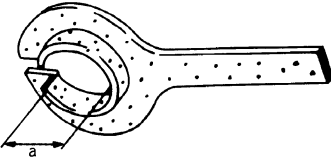
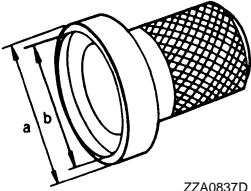
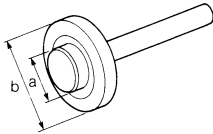
Tool number (Kent-Moore No.) Tool name	Description
KV40104000 (—) Hub lock nut wrench a: 85 mm (3.35 in) b: 65 mm (2.56 in)	Removing and Installing wheel hub lock nut.
 <p style="text-align: center;">ZZA0802D</p>	
KV40107300 (—) Boot band crimping tool	Installing boot band
 <p style="text-align: center;">ZZA1229D</p>	
KV40107500 (—) Drive shaft attachment	Removing drive shaft
 <p style="text-align: center;">ZZA1230D</p>	
KV38107900 (—) Protector a: 32 mm (1.26 in) dia.	Installing drive shaft
 <p style="text-align: center;">PDIA1183J</p>	
ST35271000 (J-26091) Drift a: 72 mm (2.83 in) dia. b: 63 mm (2.48 in) dia.	Installing support bearing
 <p style="text-align: center;">ZZA0837D</p>	
ST17130000 (—) Drift a: 32 mm (1.26 in) dia. b: 60 mm (2.36 in) dia.	Removing support bearing
 <p style="text-align: center;">ZZA0836D</p>	

A
B
C
FAX
E
F
G
H
I
J
K
L
M
N
O
P

PREPARATION

< PREPARATION >

Commercial Service Tools

INFOID:000000007050906

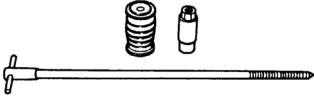
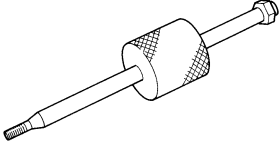
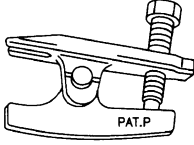
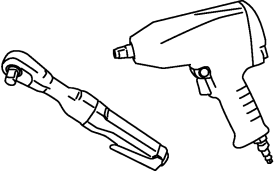
Tool name	Description
<p data-bbox="155 289 326 315">Drive shaft puller</p>  <p data-bbox="881 506 967 525">JPDIG0152ZZ</p>	<p data-bbox="1052 289 1458 315">Removing drive shaft joint sub assembly</p>
<p data-bbox="155 543 313 569">Sliding hammer</p>  <p data-bbox="881 758 948 777">ZZA0023D</p>	<p data-bbox="1052 543 1268 569">Removing drive shaft</p>
<p data-bbox="155 798 329 823">Ball joint remover</p>  <p data-bbox="841 947 878 966">PAT.P</p> <p data-bbox="881 1010 927 1029">NT146</p>	<p data-bbox="1052 798 1243 823">Removing hub bolt</p>
<p data-bbox="155 1052 261 1077">Power tool</p>  <p data-bbox="881 1262 951 1281">PBIC0190E</p>	<p data-bbox="1052 1052 1304 1077">Loosening bolts and nuts</p>

NOISE, VIBRATION AND HARSHNESS (NVH) TROUBLESHOOTING

< SYMPTOM DIAGNOSIS >

SYMPTOM DIAGNOSIS

NOISE, VIBRATION AND HARSHNESS (NVH) TROUBLESHOOTING

NVH Troubleshooting Chart

INFOID:000000007050907

Use chart below to find the cause of the symptom. If necessary, repair or replace these parts.

Reference			—	FAX-29, "Inspection"	—	FAX-8, "Exploded View"	—	FAX-6, "Inspection"	NVH in FAX and FSU sections	Refer to FRONT AXLE in this chart	NVH in WT section	NVH in WT section	Refer to DRIVE SHAFT in this chart	NVH in BR section	NVH in ST section	
Possible cause and SUSPECTED PARTS			Excessive joint angle	Joint sliding resistance	Imbalance	Improper installation, looseness	Parts interference	Wheel bearing damage	FRONT AXLE AND FRONT SUSPENSION	FRONT AXLE	TIRE	ROAD WHEEL	DRIVE SHAFT	BRAKE	STEERING	
Symptom	DRIVE SHAFT	Noise	x	x				x	x	x	x	x		x	x	
		Shake	x		x				x	x	x	x		x	x	
	FRONT AXLE	Noise				x	x	x	x		x	x	x	x	x	x
		Shake				x	x	x	x		x	x	x	x	x	x
		Vibration				x	x	x	x		x		x			x
		Shimmy				x	x		x		x	x		x	x	x
		Judder				x			x		x	x		x	x	x
		Poor quality ride or handling				x	x		x		x	x				

x: Applicable

A
B
C
E
F
G
H
I
J
K
L
M
N
O
P

FAX

FRONT WHEEL HUB AND KNUCKLE

< PERIODIC MAINTENANCE >

PERIODIC MAINTENANCE

FRONT WHEEL HUB AND KNUCKLE

Inspection

INFOID:000000007050908

COMPONENT PART

Check that the mounting conditions (looseness, backlash) of each component and component conditions (wear, damage) are normal.

WHEEL HUB ASSEMBLY (BEARING-INTEGRATED TYPE)

Check the following items, and replace the part if necessary.

- Move wheel hub assembly in the axial direction by hand. Check there is no looseness of wheel bearing.

Axial end play : Refer to [FAX-30. "Wheel Bearing"](#).

- Rotate wheel hub assembly and check there is no unusual noise or other irregular conditions. If there is any of irregular conditions, replace wheel hub assembly.

FRONT DRIVE SHAFT

< PERIODIC MAINTENANCE >

FRONT DRIVE SHAFT

Inspection

INFOID:000000007050909

Check the following items, and replace the part if necessary.

- Check drive shaft mounting point and joint for looseness and other damage.

CAUTION:

Replace entire drive shaft assembly when noise or vibration occurs from drive shaft.

- Check boot for cracks and other damage.

A

B

C

FAX

E

F

G

H

I

J

K

L

M

N

O

P

FRONT WHEEL HUB AND KNUCKLE

< REMOVAL AND INSTALLATION >

REMOVAL AND INSTALLATION

FRONT WHEEL HUB AND KNUCKLE

Exploded View

INFOID:000000007050910

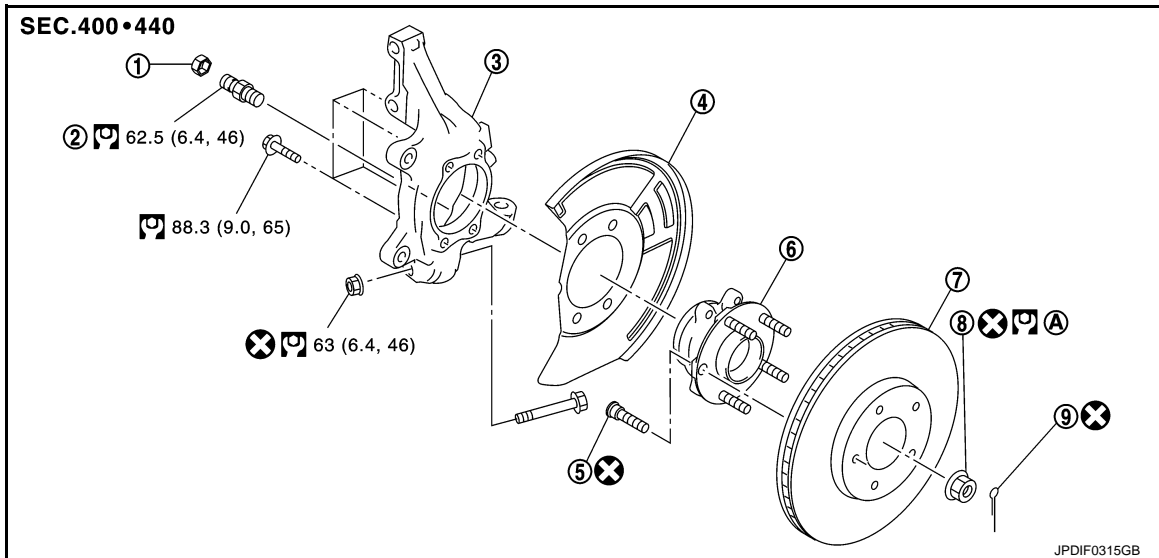

- | | | |
|-----------------|-----------------------|-------------------------------------------------|
| 1. Stopper cap | 2. Stopper bolt | 3. Steering knuckle |
| 4. Splash guard | 5. Hub bolt | 6. Wheel hub assembly (Bearing-integrated type) |
| 7. Disc rotor | 8. Wheel hub lock nut | 9. Cotter pin |

A. Tightening must be done following the installation procedure. Refer to [FAX-8, "Removal and Installation"](#).

: N·m (kg·m, ft·lb)

: Always replace after every disassembly.

Removal and Installation

INFOID:000000007050911

REMOVAL

1. Remove tires with power tool. Refer to [WT-46, "Exploded View"](#).
2. Remove wheel sensor. Refer to [BRC-118, "FRONT WHEEL SENSOR : Removal and Installation"](#).
3. Remove lock plate from strut assembly. Refer to [BR-20, "FRONT : Exploded View"](#).
4. Remove caliper assembly. Hang caliper assembly not to interfere with work. Refer to [BR-39, "BRAKE CALIPER ASSEMBLY : Removal and Installation"](#).

CAUTION:

Never depress brake pedal while brake caliper is removed.

5. Remove disc rotor.

CAUTION:

- Put matching marks (A) on the wheel hub assembly and the disc rotor before removing the disc rotor.
- Never drop disc rotor.

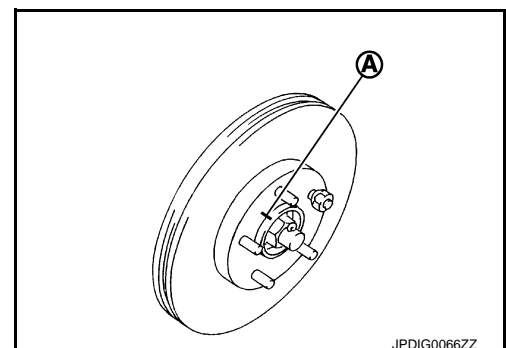

FRONT WHEEL HUB AND KNUCKLE

< REMOVAL AND INSTALLATION >

6. Remove cotter pin, and then loosen wheel hub lock nut, using a hub lock nut wrench (A) [SST: KV40104000 (—)].

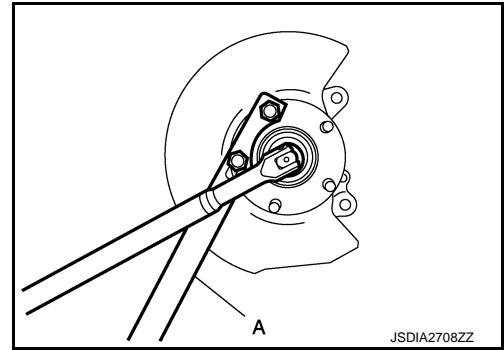

7. Patch wheel hub lock nut with a piece of wood. Hammer the wood to disengage wheel hub assembly from drive shaft.

NOTE:

Use suitable puller, if wheel hub assembly and drive shaft cannot be separated even after performing the above procedure.

8. Remove wheel hub lock nut.
9. Remove strut assembly from steering knuckle. Refer to [FSU-8, "Removal and Installation"](#).
10. Remove drive shaft from wheel hub assembly. Hang drive shaft not to interfere with work.

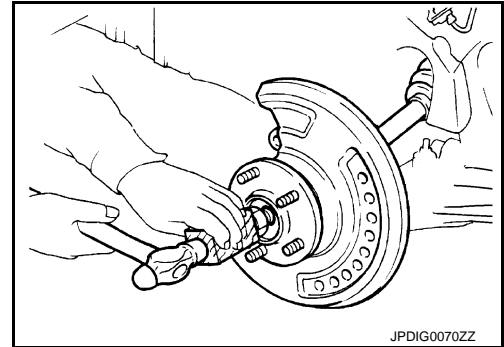

CAUTION:

- Never place drive shaft joint at an extreme angle. Also be careful not to overextend slide joint.
- Never allow drive shaft to hang down without support for joint sub-assembly, shaft and the other parts.

11. Remove wheel hub assembly and splash guard from steering knuckle.
12. Separate steering outer socket from steering knuckle. Refer to [ST-21, "Removal and Installation"](#).
13. Separate steering knuckle from transverse link.
14. Remove stopper cap and stopper bolt from steering knuckle.
15. Remove hub bolts (1) from wheel hub assembly, using the ball joint remover (A) (commercial service tool).

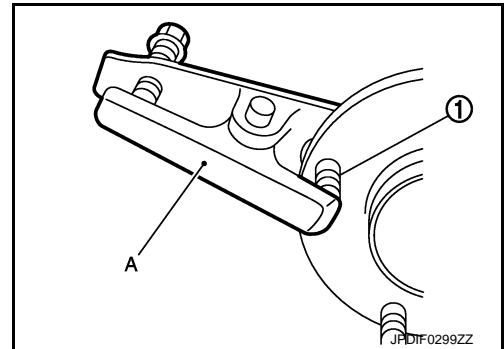

CAUTION:

- Remove hub bolt only when necessary.
- Never hammer the hub bolt to avoid impact to the wheel hub assembly.
- Pull out the hub bolt in a direction perpendicular to the wheel hub assembly.

16. Perform inspection after removal. Refer to [FAX-10, "Inspection"](#).

INSTALLATION

Note the following, and install in the reverse order of the removal.

- Place a washer (A) as shown in the figure to install the hub bolts (1) by using the tightening force of the nut (B).

CAUTION:

- Check that there is no clearance between wheel hub assembly, and hub bolt.
- Never reuse hub bolt.
- Never reuse steering knuckle and transverse link fixing nut.
- Clean the matching surface of wheel hub lock nut and wheel hub assembly.

CAUTION:

Never apply lubricating oil to these matching surface.

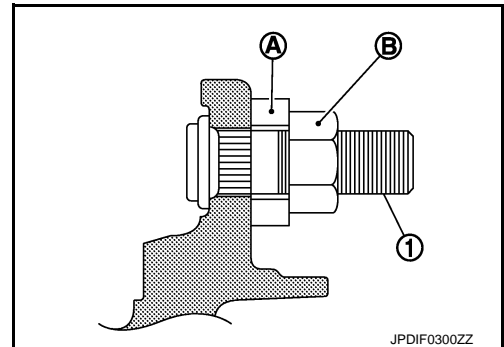

A
B
C
FAX
E
F
G
H
I
J
K
L
M
N
O
P

FRONT WHEEL HUB AND KNUCKLE

< REMOVAL AND INSTALLATION >

- Clean the matching surface of drive shaft, wheel hub assembly. And then apply paste [service parts (440037S000)] to surface (A) of joint sub-assembly of drive shaft.

CAUTION:

Apply paste to cover entire flat surface of joint sub-assembly of drive shaft.

Amount paste : 1.0 – 3.0 g (0.04 – 0.10 oz)

- Use the following torque range for tightening the wheel hub lock nut.

 : **206 – 211 N·m (21.1 – 21.5 kg-m, 152 – 155 ft-lb)**

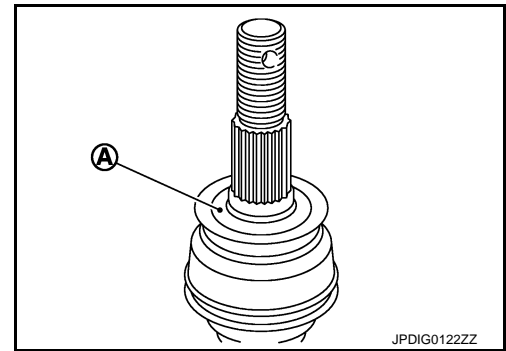

CAUTION:

- **Since the drive shaft is assembled by press-fitting, use the tightening torque range for the wheel hub lock nut.**
- **Be sure to use torque wrench to tighten the wheel hub lock nut. Never use a power tool.**
- **Never reuse wheel hub lock nut.**

NOTE:

- Wheel hub lock nut tightening torque does not over torque for avoiding axle noise, and does not less than torque for avoiding looseness.
- Align the matching marks that have been made during removal when reusing the disc rotor.
- When installing a cotter pin, securely bend the basal portion to prevent rattles.

CAUTION:

- **Never reuse cotter pin.**
- **Bend cotter pin at the root sufficiently to prevent any looseness.**
- Perform the final tightening of each of parts under unladen conditions, which were removed when removing suspension component.
- Perform inspection after installation. Refer to [FAX-10, "Inspection"](#).

Inspection

INFOID:000000007050912

INSPECTION AFTER REMOVAL

Check the following items, and replace the part if necessary.

- Check components for deformation, cracks, and other damage.
- Check ball joint of transverse link and steering outer socket.
 - Transverse link: Refer to [FSU-12, "Inspection"](#).
 - Steering outer socket: Refer to [ST-29, "Inspection"](#).

INSPECTION AFTER INSTALLATION

1. Check wheel sensor harness for proper connection. Refer to [BRC-118, "FRONT WHEEL SENSOR : Exploded View"](#).
2. Check the wheel alignment. Refer to [FSU-6, "Inspection"](#).
3. Adjust neutral position of steering angle sensor. Refer to [BRC-48, "Work Procedure"](#).

FRONT DRIVE SHAFT BOOT

< REMOVAL AND INSTALLATION >

FRONT DRIVE SHAFT BOOT

Exploded View

INFOID:000000007050913

LEFT SIDE

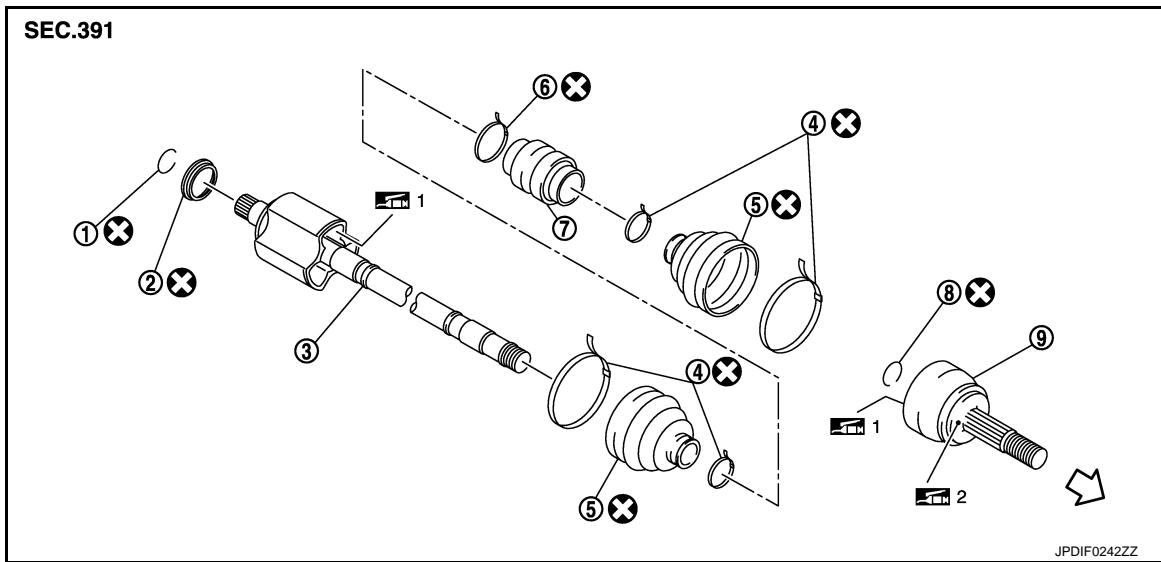

- | | | |
|-------------------|------------------|-----------------------|
| 1. Circular clip | 2. Dust shield | 3. Housing assembly |
| 4. Boot band | 5. Boot | 6. Damper band |
| 7. Dynamic damper | 8. Circular clip | 9. Joint sub-assembly |

← : Wheel side

⊗: Always replace after every disassembly.

1: Fill NISSAN Genuine grease or equivalent.

2: Apply paste [service parts (440037S000)].

RIGHT SIDE

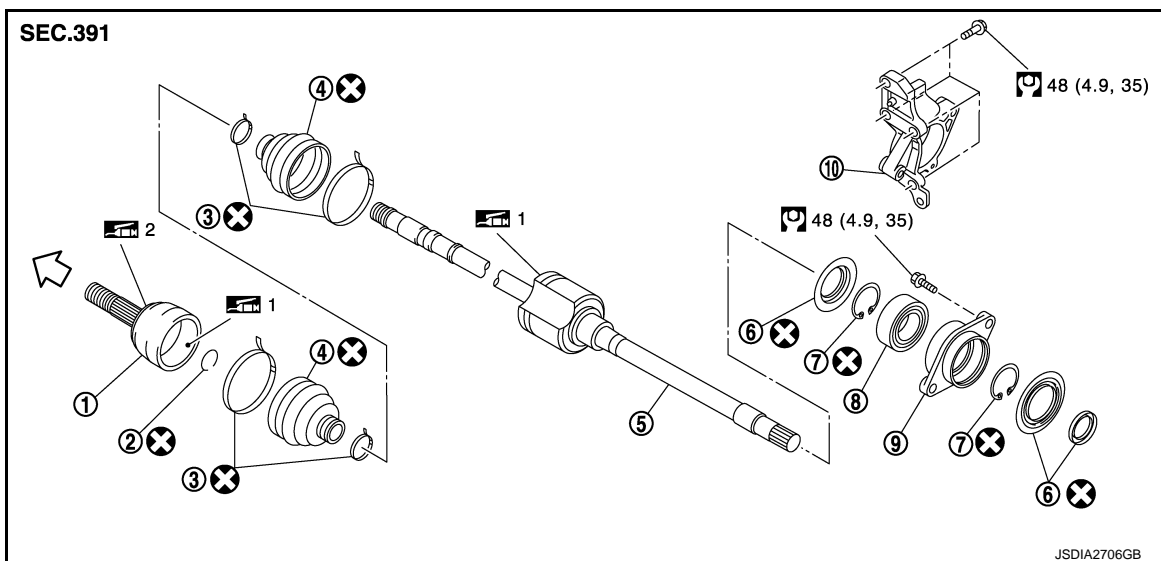



- | | | |
|-----------------------------|---------------------|--------------------|
| 1. Joint sub-assembly | 2. Circular clip | 3. Boot band |
| 4. Boot | 5. Housing assembly | 6. Dust shield |
| 7. Snap ring | 8. Support bearing | 9. Bearing housing |
| 10. Support bearing bracket | | |

FRONT DRIVE SHAFT BOOT

< REMOVAL AND INSTALLATION >

↩ : Wheel side

: N·m (kg·m, ft·lb)

: Always replace after every disassembly.

 1: Fill NISSAN Genuine grease or equivalent.

 2: Apply paste [service parts (440037S000)].

WHEEL SIDE

WHEEL SIDE : Removal and Installation

INFOID:000000007050914

REMOVAL

1. Remove tires with power tool. Refer to [WT-46, "Exploded View"](#).
2. Remove wheel sensor. Refer to [BRC-118, "FRONT WHEEL SENSOR : Removal and Installation"](#).
3. Remove lock plate from strut assembly. Refer to [BR-20, "FRONT : Exploded View"](#).
4. Remove caliper assembly. Hang caliper assembly not to interfere with work. Refer to [BR-39, "BRAKE CALIPER ASSEMBLY : Removal and Installation"](#).

CAUTION:

Never depress brake pedal while brake caliper is removed.

5. Remove disc rotor. Refer to [FAX-8, "Removal and Installation"](#).
6. Remove cotter pin, and then loosen wheel hub lock nut. Refer to [FAX-8, "Removal and Installation"](#).
7. Patch wheel hub lock nut with a piece of wood. Hammer the wood to disengage wheel hub assembly from drive shaft.

NOTE:

Use suitable puller, if wheel hub assembly and drive shaft cannot be separated even after performing the above procedure.

8. Remove wheel hub lock nut. Refer to [FAX-8, "Removal and Installation"](#).
9. Remove strut assembly from steering knuckle. Refer to [FSU-8, "Removal and Installation"](#).
10. Remove drive shaft from wheel hub assembly.

CAUTION:

- Never place drive shaft joint at an extreme angle. Also be careful not to overextend slide joint.
- Never allow drive shaft to hang down without support for joint sub-assembly, shaft and the other parts.

11. Remove boot bands, and then remove boot from joint sub-assembly.
12. Screw drive shaft puller (A) (commercial service tool) into joint sub-assembly screw part to a length of 30 mm (1.18 in) or more. Support drive shaft with one hand and pull out joint sub-assembly from housing assembly.

CAUTION:

- Align drive shaft puller and drive shaft and remove them by pulling firmly and uniformly.
- If joint sub-assembly cannot be pulled out, try after removing drive shaft from vehicle.

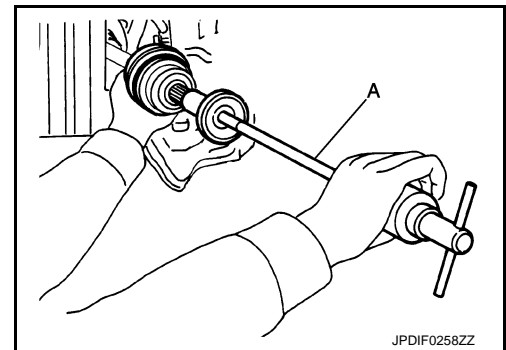
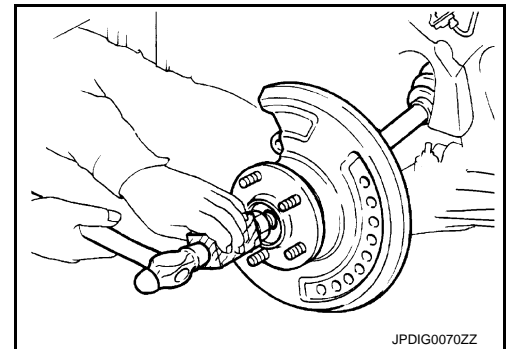

FRONT DRIVE SHAFT BOOT

< REMOVAL AND INSTALLATION >

13. Remove circular clip (1) from shaft of housing assembly.
14. Remove boot from shaft.

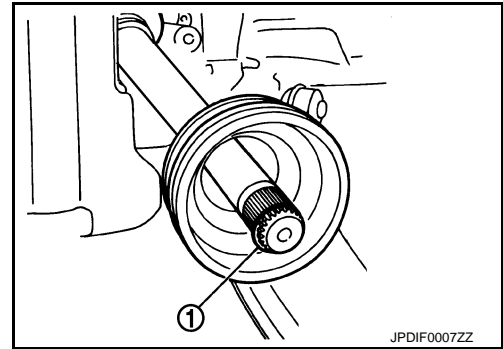

INSTALLATION

1. Clean the old grease on joint sub-assembly with paper waste.
2. Fill serration slot joint sub-assembly (1) with NISSAN genuine grease or equivalent until the serration slot and ball groove become full to the brim.

CAUTION:

After applying grease, use a paper waste to wipe off old grease that has oozed out.

3. Install boot and boot bands to shaft of housing assembly.

CAUTION:

- Wrap serration on shaft with tape to protect the boot from damage.
- Never reuse boot and boot band.

4. Remove the tape wrapped around the serration on shaft.
5. Position the circular clip (1) on groove at the shaft edge.

CAUTION:

Never reuse circular clip.

NOTE:

Drive joint inserter is recommended when installing circular clip.

6. Align both center axes of the shaft edge and joint sub-assembly. Then assemble shaft with joint sub-assembly holding circular clip.

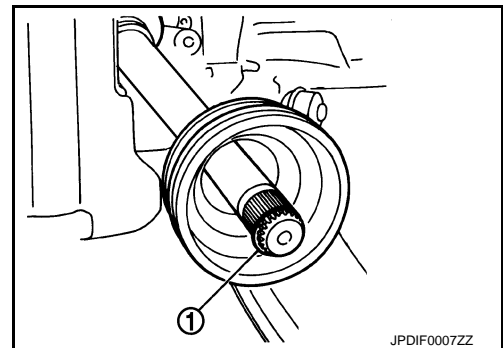
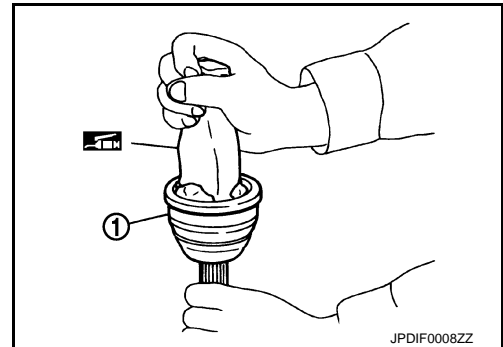

7. Install joint sub-assembly (1) to shaft using plastic hammer.

CAUTION:

- Check circular clip is properly positioned on groove of the joint sub-assembly.
- Confirm that joint sub-assembly is correctly engaged while rotating drive shaft.

8. Apply the specified amount of grease into the boot inside from large diameter side of boot.

Grease amount : Refer to [FAX-30, "Drive Shaft"](#).

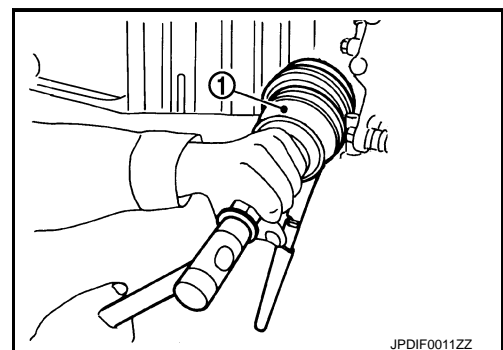

A
B
C
FAX
E
F
G
H
I
J
K
L
M
N
O
P

FRONT DRIVE SHAFT BOOT

< REMOVAL AND INSTALLATION >

9. Install the boot securely into grooves (indicated by “*” marks) shown in the figure.

L : Boot installation length

CAUTION:

If grease adheres to the boot mounting surface (indicated by “*” marks) on the shaft or joint sub-assembly, boot may be removed. Remove all grease from the boot mounting surface.

10. To prevent the deformation of the boot, adjust the boot installation length to the specified value shown below by inserting the suitable tool into inside of the boot from the large diameter side of the boot and discharging the inside air.

Boot installation length : Refer to [FAX-30, "Drive Shaft"](#).

CAUTION:

- If the boot installation length exceeds the standard, it may cause breakage of the boot.
- Be careful not to touch the inside of the boot with a tip of tool.

11. Secure the large and small ends of the boot with boot bands using the boot band crimping tool (A) [SST: KV40107300 (—)].

CAUTION:

- Never reuse boot band.

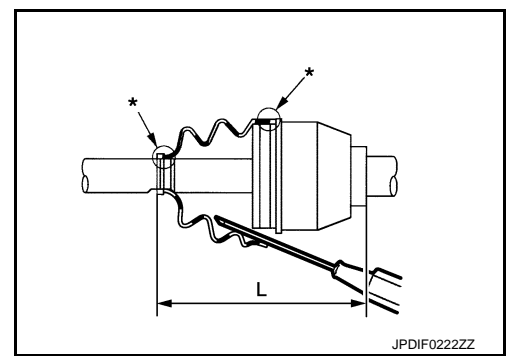

JPDIF0222ZZ

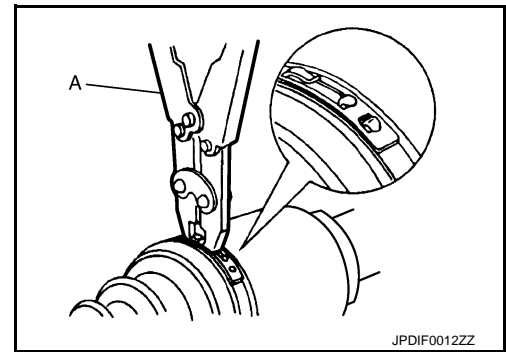

JPDIF0012ZZ

- Secure boot band so that dimension (A) meets the specification as shown in the figure.

A : 7.0 mm (0.276 in) or less.

12. Check that displacement does not occur when boot is rotated with the joint sub-assembly and shaft of housing assembly fixed.

CAUTION:

- Reinstall them using boot bands when boot installation positions become incorrect.
- Never reuse boot band.

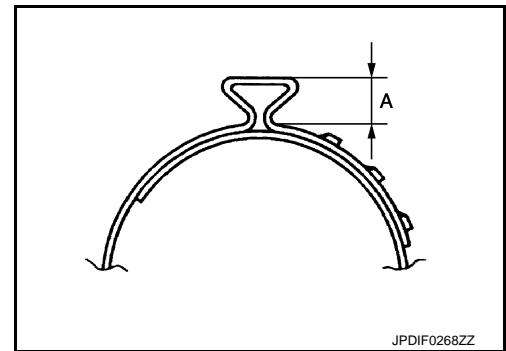

JPDIG0268ZZ

13. Clean the matching surface of wheel hub lock nut and wheel hub assembly.

CAUTION:

Never apply lubricating oil to these matching surface.

14. Clean the matching surface of drive shaft, wheel hub assembly. And then apply paste [service parts (440037S000)] to surface (A) of joint sub-assembly of drive shaft.

CAUTION:

Apply paste to cover entire flat surface of joint sub-assembly of drive shaft.

Amount paste : 1.0 – 3.0 g (0.04 – 0.10 oz)

15. Insert drive shaft to wheel hub assembly, and then temporarily tighten wheel hub lock nut.

CAUTION:

Be sure to use torque wrench to tighten the wheel hub lock nut. Never use a power tool.

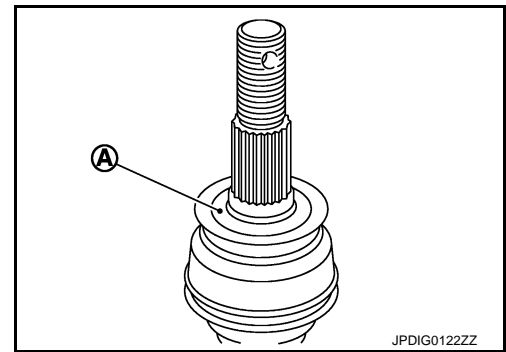

JPDIG0122ZZ

FRONT DRIVE SHAFT BOOT

< REMOVAL AND INSTALLATION >

16. Install strut assembly to steering knuckle. Refer to [FSU-8, "Exploded View"](#).
17. Install disc rotor. Refer to [FAX-8, "Removal and Installation"](#).
18. Install caliper assembly to steering knuckle. Refer to [BR-39, "BRAKE CALIPER ASSEMBLY : Removal and Installation"](#).
19. Install lock plate to strut assembly. Refer to [BR-20, "FRONT : Exploded View"](#).
20. Install wheel sensor. Refer to [BRC-118, "FRONT WHEEL SENSOR : Removal and Installation"](#).
21. Use the following torque range for tightening the wheel hub lock nut.

 : 206 – 211 N·m (21.1 – 21.5 kg·m, 152 – 155 ft·lb)

CAUTION:

- Since the drive shaft is assembled by press-fitting, use the tightening torque range for the wheel hub lock nut.
- Be sure to use torque wrench to tighten the wheel hub lock nut. Never use a power tool.
- Never reuse wheel hub lock nut.

NOTE:

Wheel hub lock nut tightening torque does not over torque for avoiding axle noise, and does not less than torque for avoiding looseness.

22. When installing a cotter pin, securely bend the basal portion to prevent rattles.

CAUTION:

- Never reuse cotter pin.
- Bend cotter pin at the root sufficiently to prevent any looseness.

23. Install tires. Refer to [WT-46, "Exploded View"](#).
24. Perform inspection after installation. Refer to [FAX-15, "Inspection"](#).

TRANSAXLE SIDE

TRANSAXLE SIDE : Removal and Installation

INFOID:000000007050915

Remove boot after drive shaft is removed from the vehicle.

- For drive shaft removal and installation, follow the instructions bellow.
 - Left side: Refer to [FAX-17, "LEFT SIDE : Removal and Installation"](#).
 - Right side: Refer to [FAX-18, "RIGHT SIDE : Removal and Installation"](#).
- For drive shaft disassembly and assembly, follow the instructions bellow.
 - Left side: Refer to [FAX-23, "TRANSAXLE SIDE : Disassembly and Assembly \(Left Side\)"](#).
 - Right side: Refer to [FAX-25, "TRANSAXLE SIDE : Disassembly and Assembly \(Right Side\)"](#).

Inspection

INFOID:000000007050916

INSPECTION AFTER INSTALLATION

1. Check wheel sensor harness for proper connection. Refer to [BRC-118, "FRONT WHEEL SENSOR : Exploded View"](#).
2. Check the wheel alignment. Refer to [FSU-6, "Inspection"](#).
3. Adjust neutral position of steering angle sensor. Refer to [BRC-48, "Work Procedure"](#).

FRONT DRIVE SHAFT

< REMOVAL AND INSTALLATION >

FRONT DRIVE SHAFT

Exploded View

INFOID:000000007216538

LEFT SIDE

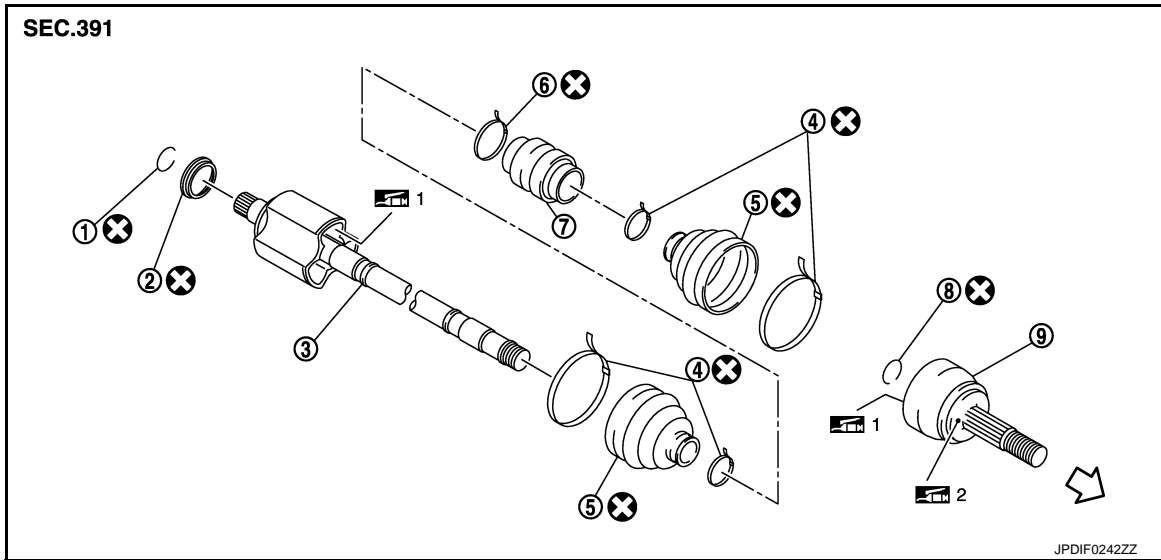

- | | | |
|-------------------|------------------|-----------------------|
| 1. Circular clip | 2. Dust shield | 3. Housing assembly |
| 4. Boot band | 5. Boot | 6. Damper band |
| 7. Dynamic damper | 8. Circular clip | 9. Joint sub-assembly |

↔ : Wheel side

⊗: Always replace after every disassembly.

1: Fill NISSAN Genuine grease or equivalent.

2: Apply paste [service parts (440037S000)].

RIGHT SIDE

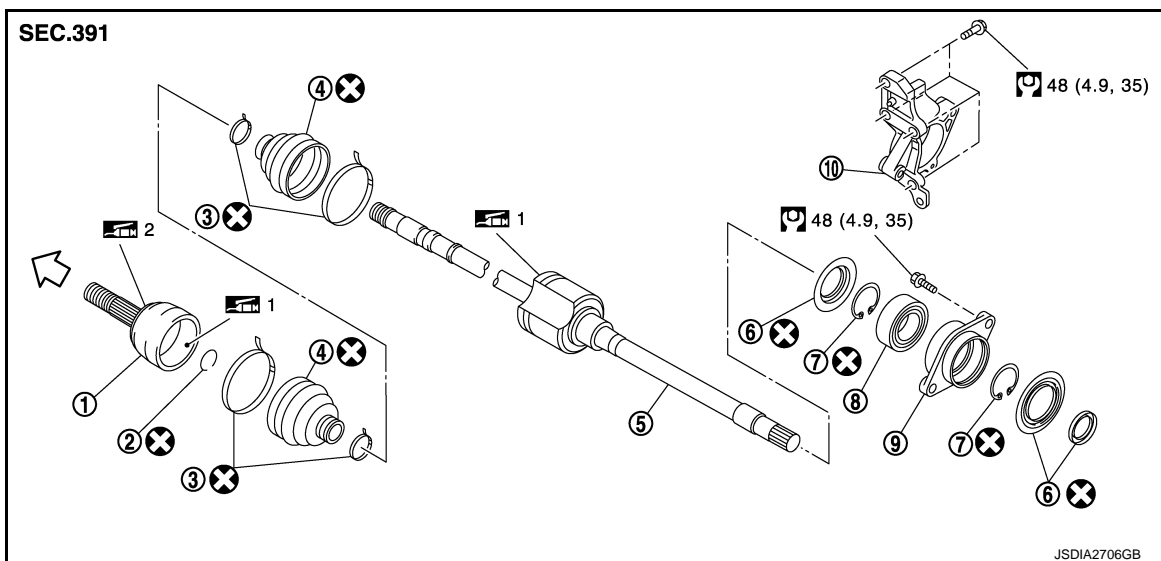

- | | | |
|-----------------------------|---------------------|--------------------|
| 1. Joint sub-assembly | 2. Circular clip | 3. Boot band |
| 4. Boot | 5. Housing assembly | 6. Dust shield |
| 7. Snap ring | 8. Support bearing | 9. Bearing housing |
| 10. Support bearing bracket | | |

FRONT DRIVE SHAFT

< REMOVAL AND INSTALLATION >

↩ : Wheel side

 : N·m (kg-m, ft-lb)

 : Always replace after every disassembly.

 1: Fill NISSAN Genuine grease or equivalent.

 2: Apply paste [service parts (440037S000)].

LEFT SIDE

LEFT SIDE : Removal and Installation

INFOID:000000007050918

A
B
C

FAX

REMOVAL

1. Remove tires with power tool. Refer to [WT-46, "Exploded View"](#).
2. Remove wheel sensor. Refer to [BRC-118, "FRONT WHEEL SENSOR : Removal and Installation"](#).
3. Remove lock plate from strut assembly. Refer to [BR-20, "FRONT : Exploded View"](#).
4. Remove caliper assembly. Hang caliper assembly not to interfere with work. Refer to [BR-39, "BRAKE CALIPER ASSEMBLY : Removal and Installation"](#).

CAUTION:

Never depress brake pedal while brake caliper is removed.

5. Remove disc rotor. Refer to [FAX-8, "Removal and Installation"](#).
6. Remove cotter pin, and then loosen wheel hub lock nut. Refer to [FAX-8, "Removal and Installation"](#).
7. Patch wheel hub lock nut with a piece of wood. Hammer the wood to disengage wheel hub assembly from drive shaft.

NOTE:

Use suitable puller, if wheel hub assembly and drive shaft cannot be separated even after performing the above procedure.

8. Remove wheel hub lock nut. Refer to [FAX-8, "Removal and Installation"](#).
9. Remove strut assembly from steering knuckle. Refer to [FSU-8, "Removal and Installation"](#).
10. Remove drive shaft from wheel hub assembly.

CAUTION:

- Never place drive shaft joint at an extreme angle. Also be careful not to overextend slide joint.
- Never allow drive shaft to hang down without support for joint sub-assembly, shaft and the other parts.

11. Use the drive shaft attachment (A) [SST: KV40107500 (—)] and a sliding hammer (B) (commercial service tool) while inserting tip of the drive shaft attachment between shaft and transaxle assembly, and then remove drive shaft from transaxle assembly.

CAUTION:

- Never place drive shaft joint at an extreme angle when removing drive shaft. Also be careful not to overextend slide joint.
- Confirm that the circular clip is attached to the drive shaft.

12. Perform inspection after removal. Refer to [FAX-29, "Inspection"](#).

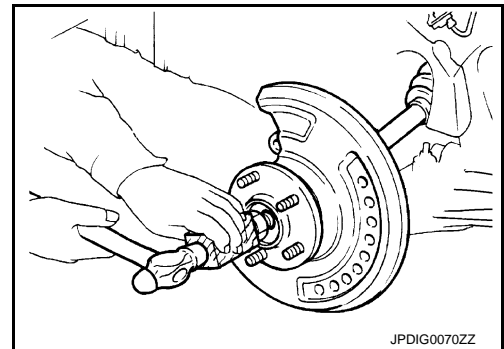

E
F
G
H
I
J
K

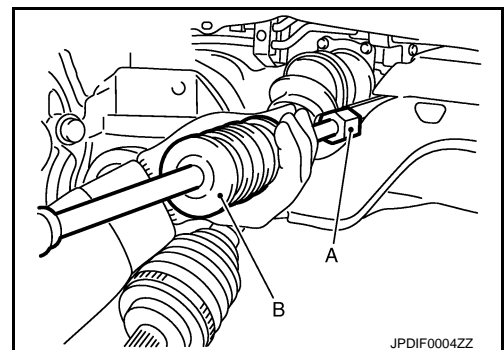

L
M
N
O
P

INSTALLATION

Note the following, and install in the reverse order of removal.

Transaxle Side

- Always replace transaxle side oil seal with new one when installing drive shaft. Refer to [TM-158, "Removal and Installation"](#).

FRONT DRIVE SHAFT

< REMOVAL AND INSTALLATION >

- Place the protector (A) [SST: KV38107900 (—)] onto transaxle assembly to prevent damage to the oil seal while inserting drive shaft. Slide drive shaft sliding joint and tap with a hammer to install securely.

CAUTION:

Check that circular clip is completely engaged.

- Perform inspection after installation. Refer to [FAX-29, "Inspection"](#).

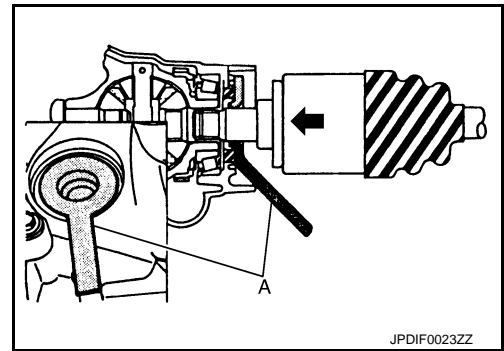

Wheel Hub Side

- Clean the matching surface of wheel hub lock nut and wheel hub assembly.

CAUTION:

Never apply lubricating oil to these matching surface.

- Clean the matching surface of drive shaft and wheel hub assembly. And then apply paste [service parts (440037S000)] to surface (A) of joint sub-assembly of drive shaft.

CAUTION:

Apply paste to cover entire flat surface of joint sub-assembly of drive shaft.

Amount paste : 1.0 – 3.0 g (0.04 – 0.10 oz)

- Use the following torque range for tightening the wheel hub lock nut.

 : **206 – 211 N·m (21.1 – 21.5 kg·m, 152 – 155 ft·lb)**

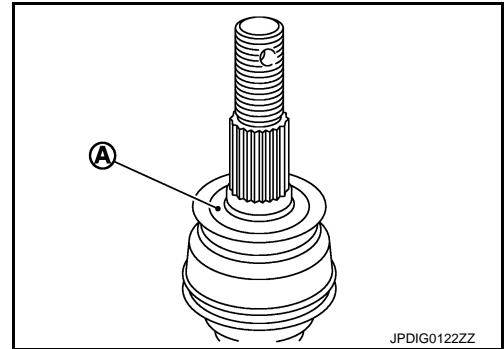

CAUTION:

- Since the drive shaft is assembled by press-fitting, use the tightening torque range for the wheel hub lock nut.
- Be sure to use torque wrench to tighten the wheel hub lock nut. Never use a power tool.
- Never reuse wheel hub lock nut.

NOTE:

Wheel hub lock nut tightening torque does not over torque for avoiding axle noise, and does not less than torque for avoiding looseness.

- Align the matching marks that have been made during removal when reusing the disc rotor.
- When installing a cotter pin, securely bend the basal portion to prevent rattles.

CAUTION:

- Never reuse cotter pin.
- Bend cotter pin at the root sufficiently to prevent any looseness.
- Perform the final tightening of each of parts under unladen conditions, which were removed when removing suspension component.
- Perform inspection after installation. Refer to [FAX-29, "Inspection"](#).

RIGHT SIDE

RIGHT SIDE : Removal and Installation

INFOID:000000007050919

REMOVAL

- Remove tires with power tool. Refer to [WT-46, "Exploded View"](#).
 - Remove wheel sensor. Refer to [BRC-118, "FRONT WHEEL SENSOR : Removal and Installation"](#).
 - Remove lock plate from strut assembly. Refer to [BR-20, "FRONT : Exploded View"](#).
 - Remove caliper assembly. Hang caliper assembly not to interfere with work. Refer to [BR-39, "BRAKE CALIPER ASSEMBLY : Removal and Installation"](#).
- CAUTION:**
Never depress brake pedal while brake caliper is removed.
- Remove disc rotor. Refer to [FAX-8, "Removal and Installation"](#).

FRONT DRIVE SHAFT

< REMOVAL AND INSTALLATION >

6. Remove cotter pin, and then loosen wheel hub lock nut. Refer to [FAX-8, "Removal and Installation"](#).
7. Patch wheel hub lock nut with a piece of wood. Hammer the wood to disengage wheel hub assembly from drive shaft.

NOTE:

Use suitable puller, if wheel hub assembly and drive shaft cannot be separated even after performing the above procedure.

8. Remove wheel hub lock nut. Refer to [FAX-8, "Removal and Installation"](#).
9. Remove strut assembly from steering knuckle. Refer to [FSU-8, "Removal and Installation"](#).
10. Remove drive shaft from wheel hub assembly.

CAUTION:

- Never place drive shaft joint at an extreme angle. Also be careful not to overextend slide joint.
- Never allow drive shaft to hang down without support for joint sub-assembly, shaft and the other parts.

11. Remove splash guard. Refer to [FAX-8, "Exploded View"](#).

12. Remove bearing housing mounting bolts.

13. Remove drive shaft assembly from transaxle assembly.

CAUTION:

Never place drive shaft joint at an extreme angle when removing drive shaft. Also be careful not to overextend slide joint.

14. Remove heat insulator from front suspension member.

15. Remove front exhaust tube. Refer to [EX-6, "Removal and Installation"](#).

16. Remove three way catalyst (bank 1) and heated oxygen sensor harness bracket. Refer to [EM-33, "Removal and Installation"](#).

17. Remove support bearing bracket.

18. Perform inspection after removal. Refer to [FAX-29, "Inspection"](#).

INSTALLATION

Note the following, and install in the reverse order of removal.

Transaxle Side

- Always replace transaxle side oil seal with new one when installing drive shaft. Refer to [TM-158, "Removal and Installation"](#).
- Place the protector (A) [SST: KV38107900 (—)] onto transaxle assembly to prevent damage to the oil seal while inserting drive shaft. Slide drive shaft sliding joint and tap with a hammer to install securely.

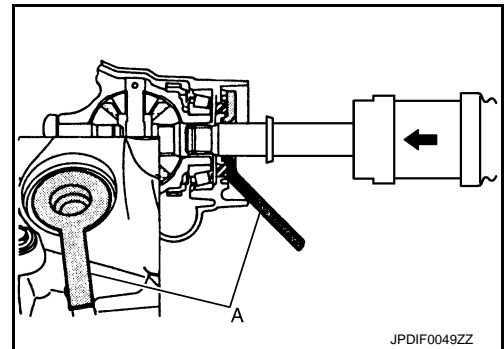
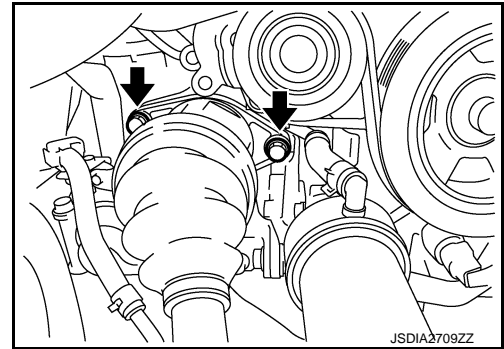
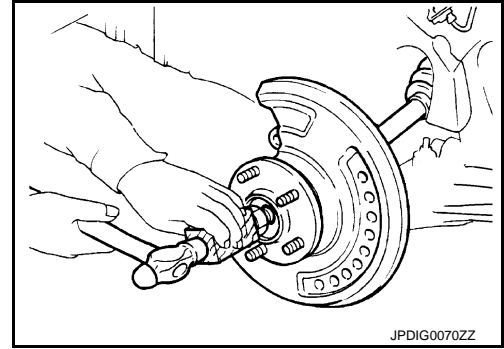

- Install support bearing bracket in following procedure.

A
B
C
FAX
E
F
G
H
I
J
K
L
M
N
O
P

FRONT DRIVE SHAFT

< REMOVAL AND INSTALLATION >

- Temporarily tighten support bearing bracket (1) mounting bolts (A), then tighten them to specified torque.

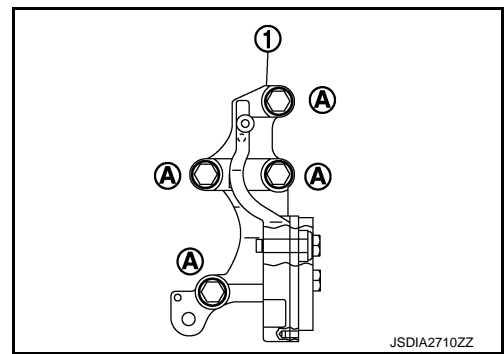

- Insert drive shaft into transaxle assembly, temporarily tighten bearing housing (1) mounting bolts (A), then tighten them to specified torque.
- Perform inspection after installation. Refer to [FAX-29, "Inspection"](#).

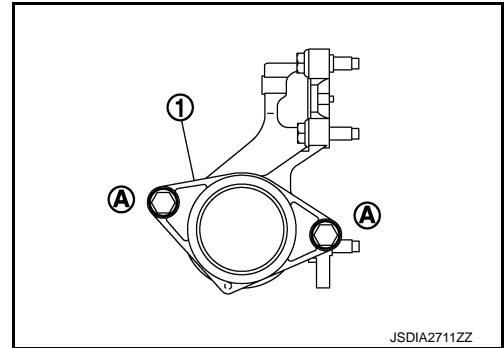

Wheel Hub Side

- Clean the matching surface of wheel hub lock nut and wheel hub assembly.

CAUTION:

Never apply lubricating oil to these matching surface.

- Clean the matching surface of drive shaft and wheel hub assembly. And then apply paste [service parts (440037S000)] to surface (A) of joint sub-assembly of drive shaft.

CAUTION:

Apply paste to cover entire flat surface of joint sub-assembly of drive shaft.

Amount paste : 1.0 – 3.0 g (0.04 – 0.10 oz)

- Use the following torque range for tightening the wheel hub lock nut.

 : **206 – 211 N·m (21.1 – 21.5 kg·m, 152 – 155 ft·lb)**

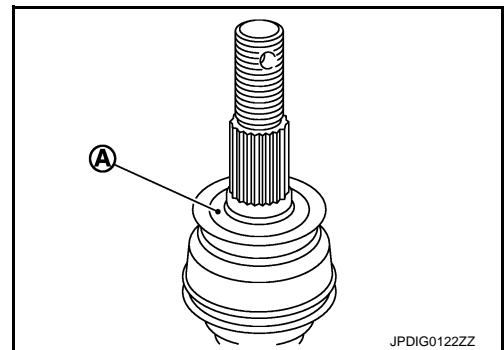

CAUTION:

- **Since the drive shaft is assembled by press-fitting, use the tightening torque range for the wheel hub lock nut.**
- **Be sure to use torque wrench to tighten the wheel hub lock nut. Never use a power tool.**
- **Never reuse wheel hub lock nut.**

NOTE:

Wheel hub lock nut tightening torque does not over torque for avoiding axle noise, and does not less than torque for avoiding looseness.

- Align the matching marks that have been made during removal when reusing the disc rotor.
- When installing a cotter pin, securely bend the basal portion to prevent rattles.

CAUTION:

- **Never reuse cotter pin.**
- **Bend cotter pin at the root sufficiently to prevent any looseness.**
- Perform the final tightening of each of parts under unladen conditions, which were removed when removing suspension component.
- Perform inspection after installation. Refer to [FAX-29, "Inspection"](#).

WHEEL SIDE

FRONT DRIVE SHAFT

< REMOVAL AND INSTALLATION >

WHEEL SIDE : Disassembly and Assembly

INFOID:000000007050920

DISASSEMBLY

1. Fix shaft of housing assembly with a vise.

CAUTION:

Protect shaft when fixing with a vise using aluminum or copper plates.

2. Remove boot bands, and then remove boot from joint sub-assembly.
3. Screw drive shaft puller (A) (commercial service tool) into joint sub-assembly screw part to a length of 30 mm (1.18 in) or more. Support drive shaft with one hand and pull out joint sub-assembly from shaft.

CAUTION:

- Align drive shaft puller and drive shaft and remove them by pulling firmly and uniformly.
- If joint sub-assembly cannot be removed after five or more unsuccessful attempts, replace shaft and joint sub-assembly as a set.

4. Remove circular clip from shaft.
5. Remove boot from shaft.
6. Perform inspection after disassembly. Refer to [FAX-29, "Inspection"](#).

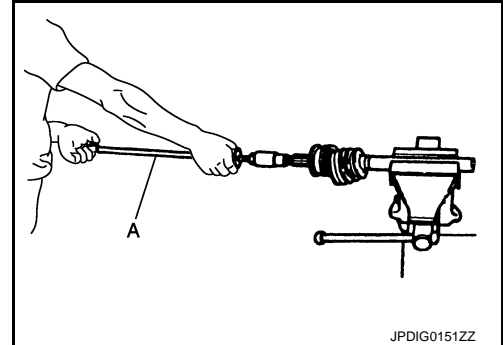

ASSEMBLY

1. Clean the old grease on joint sub-assembly with paper waste.
2. Fill serration slot joint sub-assembly (1) with NISSAN genuine grease or equivalent until the serration slot and ball groove become full to the brim.

CAUTION:

After applying grease, use a paper waste to wipe off old grease that has oozed out.

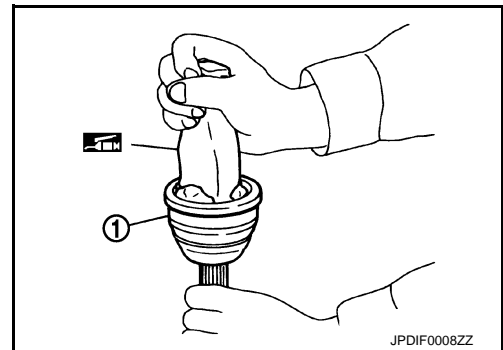

3. Install boot and boot bands to shaft of housing assembly.

CAUTION:

- Wrap serration on shaft with tape (A) to protect the boot from damage.
- Never reuse boot and boot band.

4. Remove the tape wrapped around the serration on shaft.

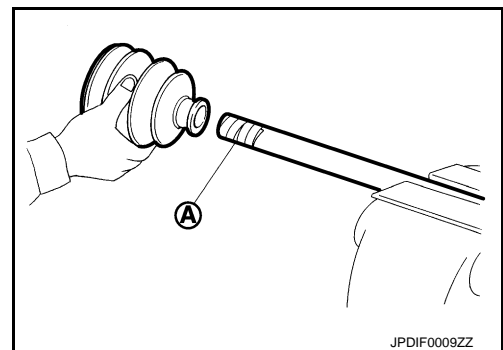

A
B
C
FAX
E
F
G
H
I
J
K
L
M
N
O
P

FRONT DRIVE SHAFT

< REMOVAL AND INSTALLATION >

5. Position the circular clip (1) on groove at the shaft edge.

CAUTION:

Never reuse circular clip.

NOTE:

Drive joint inserter is recommended when installing circular clip.

6. Align both center axes of the shaft edge and joint sub-assembly. Then assemble shaft with joint sub-assembly holding circular clip.

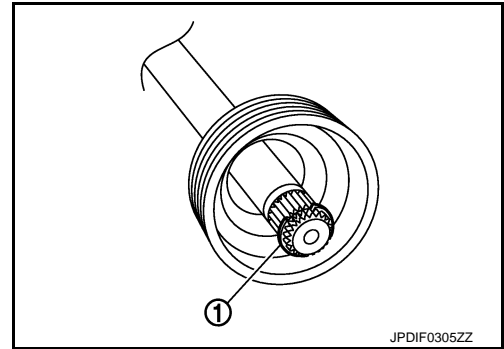

JPDIF0305ZZ

7. Install joint sub-assembly to shaft using plastic hammer.

CAUTION:

- Check circular clip is properly positioned on groove of the joint sub-assembly.
- Confirm that joint sub-assembly is correctly engaged while rotating drive shaft.

8. Apply the specified amount of grease into the boot inside from large diameter side of boot.

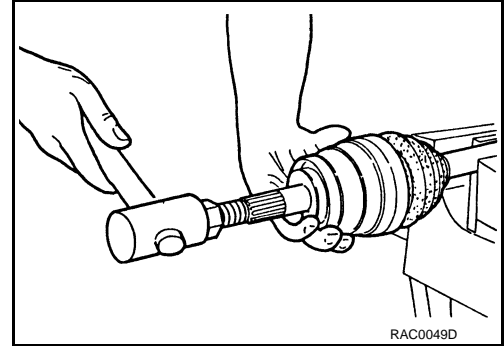

RAC0049D

Grease amount : Refer to [FAX-30, "Drive Shaft"](#).

9. Install the boot securely into grooves (indicated by "*" marks) shown in the figure.

L : Boot installation length

CAUTION:

If grease adheres to the boot mounting surface (indicated by "*" marks) on the shaft or joint sub-assembly, boot may be removed. Remove all grease from the boot mounting surface.

10. To prevent the deformation of the boot, adjust the boot installation length to the specified value shown below by inserting the suitable tool into inside of the boot from the large diameter side of the boot and discharging the inside air.

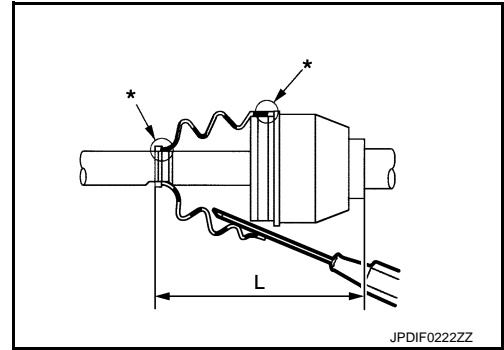

JPDIF0222ZZ

Boot installation length : Refer to [FAX-30, "Drive Shaft"](#).

CAUTION:

- If the boot installation length exceeds the standard, it may cause breakage of the boot.
- Be careful not to touch the inside of the boot with a tip of tool.

11. Secure the large and small ends of the boot with boot bands using the boot band crimping tool (A) [SST: KV40107300 (—)].

CAUTION:

- Never reuse boot band.

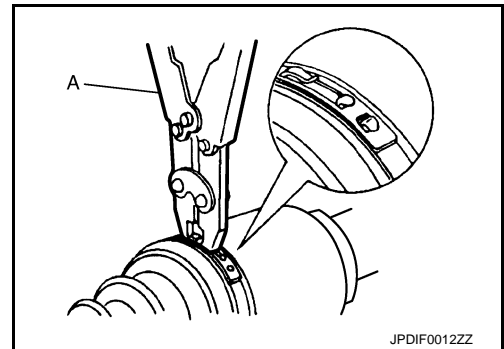

JPDIF0012ZZ

FRONT DRIVE SHAFT

< REMOVAL AND INSTALLATION >

- Secure boot band so that dimension (A) meets the specification as shown in the figure.

A : 7.0 mm (0.276 in) or less.

12. Check that displacement does not occur when boot is rotated with the joint sub-assembly and shaft of housing assembly fixed.

CAUTION:

- Reinstall them using boot bands when boot installation positions become incorrect.
- Never reuse boot band.

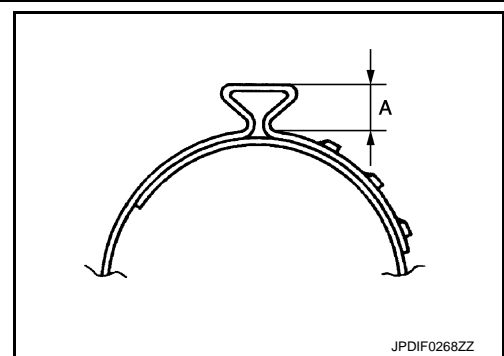

TRANSAXLE SIDE

TRANSAXLE SIDE : Disassembly and Assembly (Left Side)

INFOID:000000007050921

DISASSEMBLY

1. Fix housing assembly with a vise.

CAUTION:

Protect housing assembly using aluminum or copper plates when fixing with a vise.

2. Remove wheel side boot from joint sub-assembly. Refer to [FAX-12, "WHEEL SIDE : Removal and Installation"](#).
3. Remove damper band, then remove dynamic damper from shaft of housing assembly.
4. Remove boot bands, then remove boot from shaft of housing assembly.
5. Remove circular clip from housing assembly.
6. Remove dust shield from housing assembly.
7. Perform inspection after disassembly. Refer to [FAX-29, "Inspection"](#).

ASSEMBLY

1. Clean the old grease on housing assembly with paper waste.
2. Install dust shield to housing assembly.

CAUTION:

Never reuse dust shield.

3. Install circular clip to housing.

CAUTION:

Never reuse circular clip.

4. Install boot and boot bands to shaft of housing assembly.

CAUTION:

• Wrap serration on shaft with tape (A) to protect the boot from damage.

• Never reuse boot and boot band.

5. Remove the tape wrapped around the serration on shaft.
6. Apply NISSAN genuine grease (refer to parts catalog) to housing assembly.

Grease amount : Refer to [FAX-30, "Drive Shaft"](#).

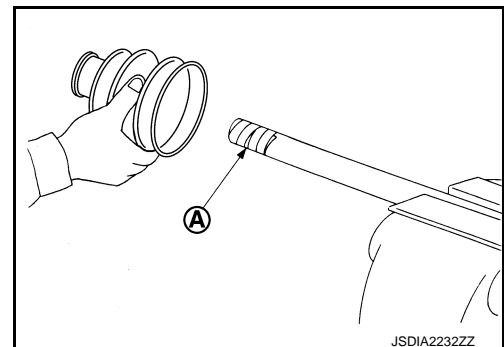

A
B
C
FAX
E
F
G
H
I
J
K
L
M
N
O
P

FRONT DRIVE SHAFT

< REMOVAL AND INSTALLATION >

7. Install boot securely into grooves (indicated by "*" marks) shown in the figure.

L : Boot installation length

CAUTION:

If grease adheres to the boot mounting surface (with "*" marks) on shaft or housing, boot may be removed. Remove all grease from the surface.

8. To prevent the deformation of the boot, adjust the boot installation length to the value shown below by inserting the suitable tool into the inside of boot from the large diameter side of boot and discharging inside air.

Boot installation length : Refer to [FAX-30, "Drive Shaft"](#).

CAUTION:

- If the boot installation length exceeds the standard, it may cause breakage of the boot.
- Be careful not to touch the inside of the boot with the tip of tool.

9. Install boot bands securely.

CAUTION:

Never reuse boot bands.

For one-touch clamp band

- Install boot bands securely as shown in the figure.

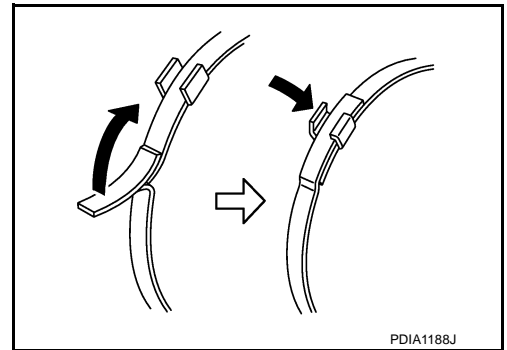
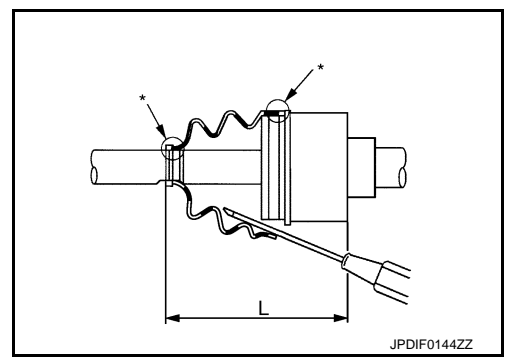

For low profile type band

1. Put boot band in the groove on drive shaft boot. Then fit pawls into holes to temporary installation.

NOTE:

For the large diameter side, fit projection (A) and guide slit (B) at first.

2. Pinch projection on the band with suitable pliers to tighten band.

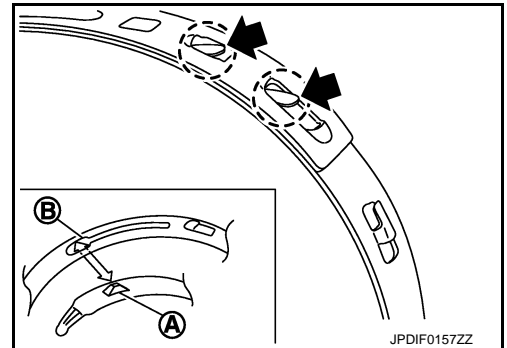

FRONT DRIVE SHAFT

< REMOVAL AND INSTALLATION >

3. Insert the tip of band into the lower part of pawl (marked with dotted circle) as shown in the figure.
10. Check that displacement does not occur when boot is rotated with the housing assembly fixed.

CAUTION:

- If displacement occurs, reinstall band.
- Never reuse boot band.

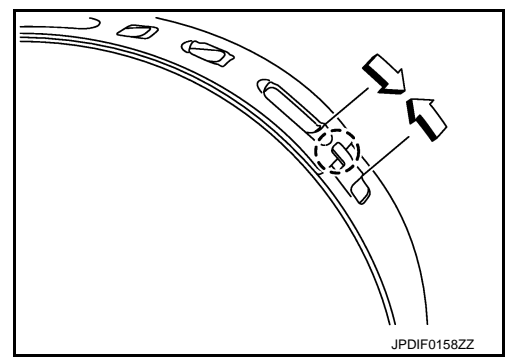

11. Install dynamic damper, follow the procedure described below.
 - a. Install dynamic damper and damper bands to shaft of housing assembly.

CAUTION:

Never reuse damper band.

- b. Install boot to the wheel side. Refer to [FAX-21, "WHEEL SIDE : Disassembly and Assembly"](#).
- c. Securely dynamic damper with damper bands in the following specified position (A) when installing.

A : Refer to [FAX-30, "Drive Shaft"](#).

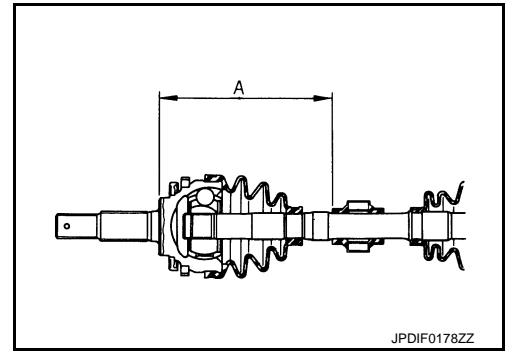

- Install damper bands securely as shown in the figure.

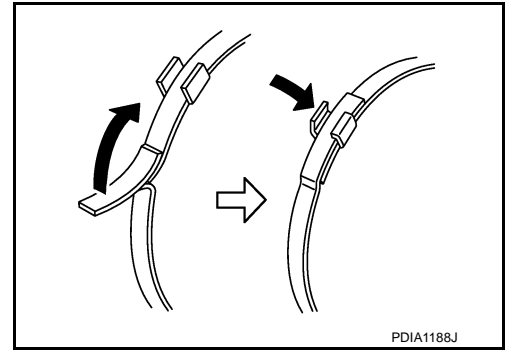

TRANSAXLE SIDE : Disassembly and Assembly (Right Side)

INFOID:000000007057524

DISASSEMBLY

1. Fix housing assembly with a vise.

CAUTION:
Protect housing assembly using aluminum or copper plates when fixing with a vise.
2. Remove wheel side boot from joint sub-assembly. Refer to [FAX-21, "WHEEL SIDE : Disassembly and Assembly"](#).
3. Remove boot bands, then remove boot from housing assembly.
4. Remove support bearing, follow the procedure described below.

FRONT DRIVE SHAFT

< REMOVAL AND INSTALLATION >

a. Remove dust shield from housing.

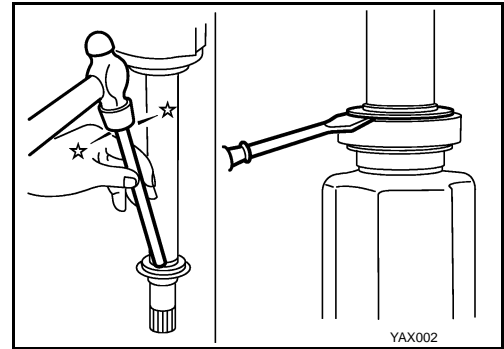

b. Remove snap ring (1).

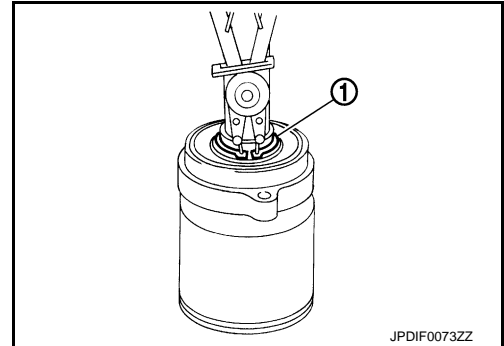

c. Press out bearing housing and support bearing from housing assembly.

d. Remove dust shield from housing assembly.

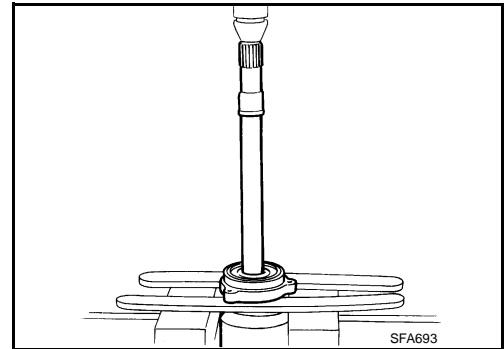

e. Remove snap ring (1).

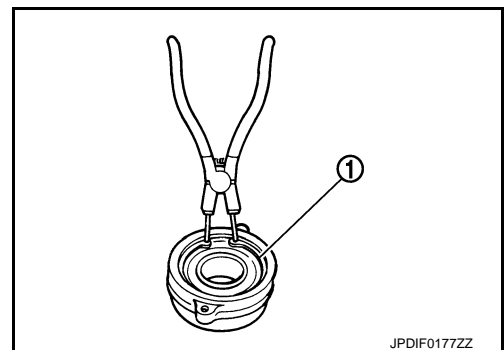

f. Press out support bearing from bearing housing (1), using the drift (A) [SST: ST17130000 (—)].

5. Perform inspection after disassembly. Refer to [FAX-29, "Inspection"](#).

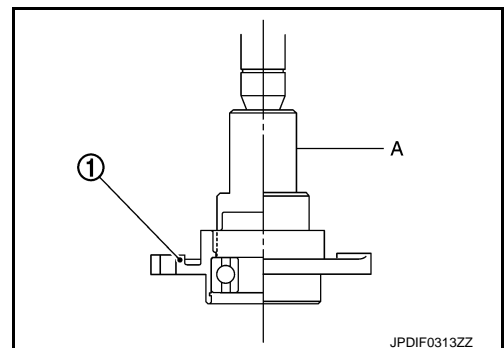

FRONT DRIVE SHAFT

< REMOVAL AND INSTALLATION >

ASSEMBLY

1. Install dust shield to housing assembly.
CAUTION:
Never reuse dust shield.
2. Install support bearing, follow the procedure described below.
 - a. Press support bearing to bearing housing (1), using the drift (A) [SST: ST35271000 (J-26091)].

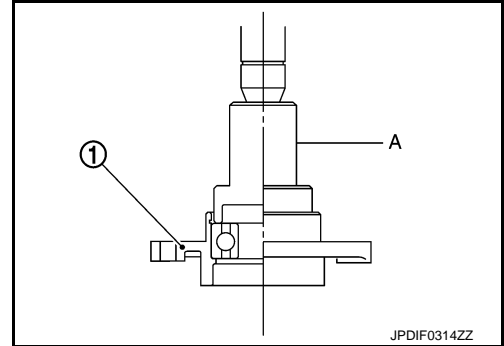

- b. Install snap ring (1).
CAUTION:
Never reuse snap ring.
 - c. Press bearing housing and support bearing to housing assembly.

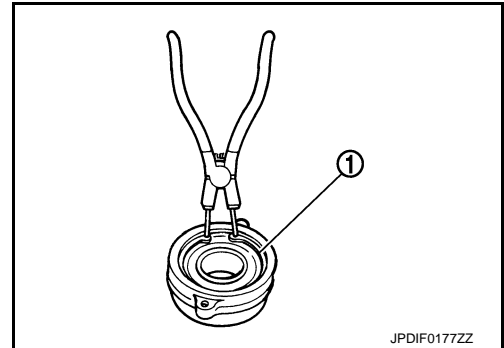

- d. Install snap ring (1).
CAUTION:
Never reuse snap ring.

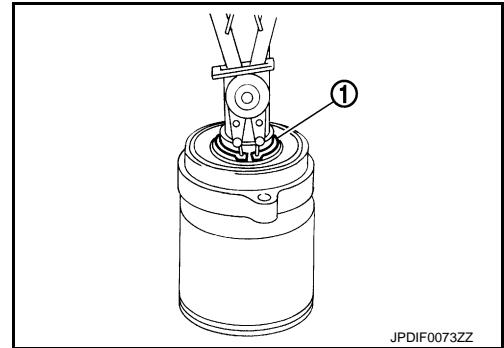

- e. Install dust shields.
CAUTION:
Never reuse dust shields.
 3. Clean the old grease on housing assembly with paper waste.

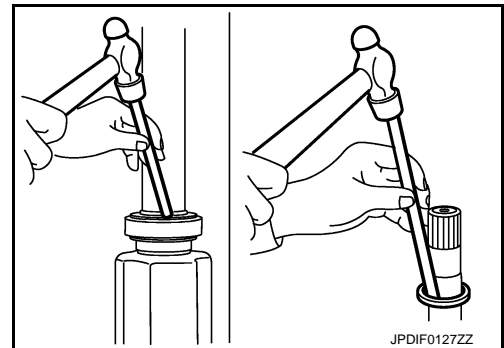

4. Install boot and boot bands to shaft of housing assembly.
CAUTION:

A
B
C
FAX
E
F
G
H
I
J
K
L
M
N
O
P

FRONT DRIVE SHAFT

< REMOVAL AND INSTALLATION >

- Wrap serration on shaft with tape (A) to protect the boot from damage.
- Never reuse boot and boot band.

- Remove the tape wrapped around the serration on shaft.
- Apply NISSAN genuine grease (refer to parts catalog) to housing assembly.

Grease amount : Refer to [FAX-30, "Drive Shaft"](#).

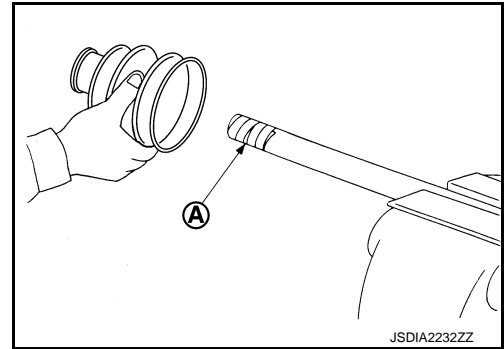

- Install boot securely into grooves (indicated by "*" marks) shown in the figure.

L : Boot installation length

CAUTION:

If grease adheres to the boot mounting surface (with "*" marks) on shaft or housing, boot may be removed. Remove all grease from the surface.

- To prevent the deformation of the boot, adjust the boot installation length to the value shown below (L) by inserting the suitable tool into the inside of boot from the large diameter side of boot and discharging inside air.

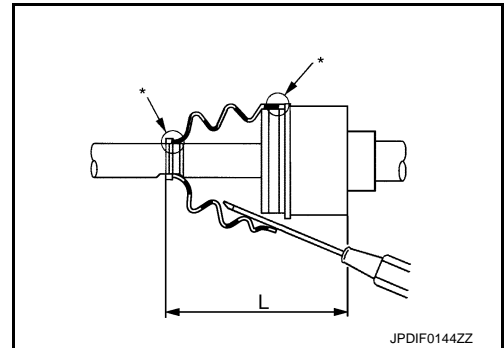

Boot installation length : Refer to [FAX-30, "Drive Shaft"](#).

CAUTION:

- If the boot installation length exceeds the standard, it may cause breakage of the boot.
- Be careful not to touch the inside of the boot with the tip of tool.

- Install boot bands securely.

CAUTION:

Never reuse boot bands.

- Put boot band in the groove on drive shaft boot. Then fit pawls into holes to temporary installation.

NOTE:

For the large diameter side, fit projection (A) and guide slit (B) at first.

- Pinch projection on the band with suitable pliers to tighten band.

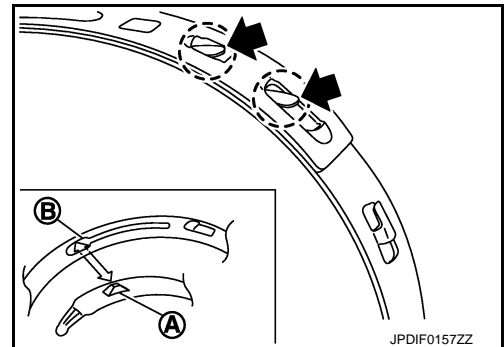

- Insert the tip of band into the lower part of pawl (marked with dotted circle) as shown in the figure.

- Check that displacement does not occur when boot is rotated with the housing assembly fixed.

CAUTION:

- If displacement occurs, reinstall band.
- Never reuse boot band.

- Install boot to the wheel side. Refer to [FAX-21, "WHEEL SIDE : Disassembly and Assembly"](#).

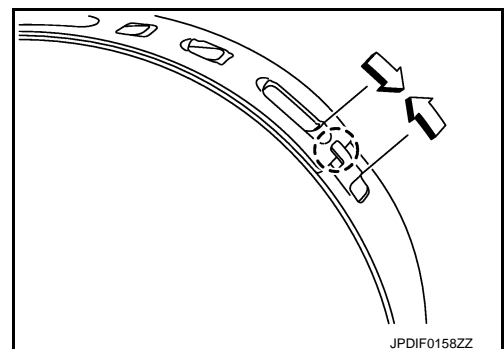

FRONT DRIVE SHAFT

< REMOVAL AND INSTALLATION >

Inspection

INFOID:000000007050922

A

INSPECTION AFTER REMOVAL

Check the following items, and replace the part if necessary.

- Move joint up/down, left/right, and in the axial directions. Check for motion that is not smooth and for significant looseness.
- Check boot for cracks, damage, and leakage of grease.
- Check the support bearing bracket for cracks, deformation and other damage.

B

C

INSPECTION AFTER DISASSEMBLY

Check the following items, and replace the part if necessary.

Dynamic Damper (Left Side)

Check damper for cracks or wear.

FAX

Joint Sub-Assembly

Check the following:

- Joint sub-assembly for rough rotation and excessive axial looseness.
- The inside of the joint sub-assembly for entry of foreign material.
- Joint sub-assembly for compression scars, cracks, and fractures inside of joint sub-assembly.

Replace joint sub-assembly if there are any non-standard conditions of components.

E

F

Housing assembly

- Replace housing assembly if there is scratching or wear of housing assembly roller contact surface.
- Check shaft for runout, cracks, or other damage.

G

Support Bearing (Right Side)

Check bearing rolls freely and is free from noise, cracks, pitting or wear. Replace support bearing if there are any non-standard conditions.

H

Bearing Housing (Right Side)

Check for bearing housing, cracks, or damage. Replace support bearing bracket if there are any non-standard conditions.

I

INSPECTION AFTER INSTALLATION

1. Check wheel sensor harness for proper connection. Refer to [BRC-118, "FRONT WHEEL SENSOR : Exploded View"](#).
2. Check the wheel alignment. Refer to [FSU-6, "Inspection"](#).
3. Adjust neutral position of steering angle sensor. Refer to [BRC-48, "Work Procedure"](#).

J

K

L

M

N

O

P

SERVICE DATA AND SPECIFICATIONS (SDS)

< SERVICE DATA AND SPECIFICATIONS (SDS)

SERVICE DATA AND SPECIFICATIONS (SDS)

SERVICE DATA AND SPECIFICATIONS (SDS)

Wheel Bearing

INFOID:000000007050923

Item	Standard
Axial end play	0.05 mm (0.002 in) or less

Drive Shaft

INFOID:000000007050924

Item		Standard	
		Left side	Right side
Grease quantity	Wheel side	170 – 190 g (6.00 – 6.70 oz)	
	Transaxle side	155 – 175 g (5.47 – 6.17 oz)	
Boots installed length*	Wheel side	158.6 mm (6.24 in)	
	Transaxle side	163.67 mm (6.44 in)	
Dimension of dynamic damper*		237 – 243 mm (9.33 – 9.57 in)	—

*: For measuring position, refer to [FAX-21, "WHEEL SIDE : Disassembly and Assembly"](#) (Wheel side), [FAX-23, "TRANSAXLE SIDE : Disassembly and Assembly \(Left Side\)"](#) [Transaxle side (Left side)], [FAX-25, "TRANSAXLE SIDE : Disassembly and Assembly \(Right Side\)"](#) [Transaxle side (Right side)].