

SECTION **SR**
SRS AIRBAG

A
B
C
D
E
F
G
SR
I
J
K
L
M
N
O
P

CONTENTS

PRECAUTION	2	SPIRAL CABLE	14
PRECAUTIONS	2	Exploded View	14
Precaution for Supplemental Restraint System (SRS) "AIR BAG" and "SEAT BELT PRE-TENSIONER"	2	Removal and Installation	14
Service	2	PASSENGER AIR BAG MODULE	17
PREPARATION	3	Exploded View	17
PREPARATION	3	Removal and Installation	17
Commercial Service Tools	3	CURTAIN AIR BAG MODULE	20
BASIC INSPECTION	4	Exploded View	20
COLLISION DIAGNOSIS	4	Removal and Installation	20
FOR FRONTAL COLLISION	4	CRASH ZONE SENSOR	22
FOR FRONTAL COLLISION : When SRS is activated in a collision	4	Exploded View	22
FOR FRONTAL COLLISION : When SRS is not activated in a collision	5	Removal and Installation	22
FOR SIDE AND ROLLOVER COLLISION	6	SATELLITE SENSOR	24
FOR SIDE AND ROLLOVER COLLISION : When SRS is activated in a collision	6	Exploded View	24
FOR SIDE AND ROLLOVER COLLISION : When SRS is not activated in a collision	7	Removal and Installation	25
REMOVAL AND INSTALLATION	11	DIAGNOSIS SENSOR UNIT	28
DRIVER AIR BAG MODULE	11	Exploded View	28
Exploded View	11	Removal and Installation	28
Removal and Installation	11	SEAT BELT PRE-TENSIONER	30
		Exploded View	30
		Removal and Installation	30
		OCCUPANT DETECTION SYSTEM CONTROL UNIT	31
		Exploded View	31
		Removal and Installation	31

PRECAUTIONS

< PRECAUTION >

PRECAUTION

PRECAUTIONS

Precaution for Supplemental Restraint System (SRS) "AIR BAG" and "SEAT BELT PRE-TENSIONER"

INFOID:000000007150004

The Supplemental Restraint System such as "AIR BAG" and "SEAT BELT PRE-TENSIONER", used along with a front seat belt, helps to reduce the risk or severity of injury to the driver and front passenger for certain types of collision. This system includes seat belt switch inputs and dual stage front air bag modules. The SRS system uses the seat belt switches to determine the front air bag deployment, and may only deploy one front air bag, depending on the severity of a collision and whether the front occupants are belted or unbelted. Information necessary to service the system safely is included in the "SRS AIR BAG" and "SEAT BELT" of this Service Manual.

WARNING:

Always observe the following items for preventing accidental activation.

- **To avoid rendering the SRS inoperative, which could increase the risk of personal injury or death in the event of a collision that would result in air bag inflation, all maintenance must be performed by an authorized NISSAN/INFINITI dealer.**
- **Improper maintenance, including incorrect removal and installation of the SRS, can lead to personal injury caused by unintentional activation of the system. For removal of Spiral Cable and Air Bag Module, see "SRS AIR BAG".**
- **Never use electrical test equipment on any circuit related to the SRS unless instructed to in this Service Manual. SRS wiring harnesses can be identified by yellow and/or orange harnesses or harness connectors.**

PRECAUTIONS WHEN USING POWER TOOLS (AIR OR ELECTRIC) AND HAMMERS

WARNING:

Always observe the following items for preventing accidental activation.

- **When working near the Air Bag Diagnosis Sensor Unit or other Air Bag System sensors with the ignition ON or engine running, never use air or electric power tools or strike near the sensor(s) with a hammer. Heavy vibration could activate the sensor(s) and deploy the air bag(s), possibly causing serious injury.**
- **When using air or electric power tools or hammers, always switch the ignition OFF, disconnect the battery, and wait at least 3 minutes before performing any service.**

Service

INFOID:000000007095645

- Never use electrical test equipment to check SRS circuits unless instructed to in this Service Manual.
- Before servicing the SRS, turn ignition switch OFF, disconnect battery negative terminal and wait at least 3 minutes.
For approximately 3 minutes after the battery negative terminal are removed, it is still possible for the air bag and seat belt pre-tensioner to deploy. Therefore, never work on any SRS connectors or wires until at least 3 minutes have elapsed.
- Diagnosis sensor unit must always be installed with their arrow marks "←" pointing towards the front of the vehicle for proper operation. Also check diagnosis sensor unit for cracks, deformities or rust before installation and replace as required.
- The spiral cable must be aligned in the neutral position since its rotations are limited. Never turn steering wheel and column after removal of steering gear.
- Handle air bag module carefully. Always place driver and front passenger air bag modules with the pad side facing upward and seat mounted front side air bag module standing with the stud bolt side facing down.
- Conduct self-diagnosis to check entire SRS for proper functioning after replacing any components.
- After air bag inflates, the front instrument panel assembly should be replaced if damaged.
- Always replace instrument panel pad following front passenger air bag deployment.

PREPARATION

< PREPARATION >

PREPARATION

PREPARATION

Commercial Service Tools

INFOID:000000007149792

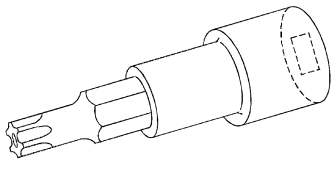
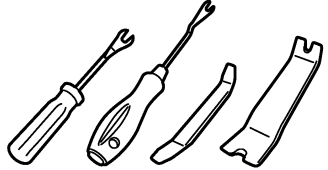
Tool name	Description
<p data-bbox="159 514 430 546">Tamper resistant TORX bit</p>  <p data-bbox="771 630 836 651">S-NT757</p>	<p data-bbox="1006 514 1356 546">Removes of driver air bag module</p>
<p data-bbox="159 766 300 798">Remover tool</p>  <p data-bbox="771 882 868 903">JMKIA3050ZZ</p>	<p data-bbox="1006 766 1388 798">Removes clips, pawls and metal clips</p>

A
B
C
D
E
F
G
SR
I
J
K
L
M
N
O
P

SR

COLLISION DIAGNOSIS

< BASIC INSPECTION >

BASIC INSPECTION

COLLISION DIAGNOSIS FOR FRONTAL COLLISION

FOR FRONTAL COLLISION : When SRS is activated in a collision

INFOID:000000007095647

CAUTION:

Due to varying models and option levels, not all parts listed in the chart below apply to all vehicles.

WORK PROCEDURE

1. Before performing any of the following steps, ensure that all vehicle body and structural repairs have been completed.
2. Replace the diagnosis sensor unit.
3. Remove the front air bag modules, crash zone sensor, bracket and seat belt pre-tensioner assemblies.
4. Check the SRS components using the table below:
Replace any SRS components showing visible signs of damage. (dents, cracks and deformation, etc.)
5. Install new front air bag modules, crash zone sensor assembly, bracket and seat belt pre-tensioner assemblies.
6. Perform self-diagnosis using CONSULT or air bag warning lamp. Refer to [SRC-19, "CONSULT Function"](#) or [SRC-15, "On Board Diagnosis Function"](#) for details. Ensure entire SRS operates properly.
7. After the work is completed, perform self-diagnosis to check that no malfunction is detected. Refer to [SRC-15, "Description"](#).

SRS INSPECTION (FOR FRONTAL COLLISION)

Part	Inspection
Driver air bag module	If the driver air bag has deployed: REPLACE Install with new fasteners.
Passenger air bag module (if equipped)	If the passenger air bag has deployed: REPLACE Install with new fasteners.
Crash zone sensor	If any of the front air bags or seat belt pre-tensioners* have been activated: REPLACE the crash zone sensor and bracket with new fasteners. *: Confirm seat belt pre-tensioner activation using CONSULT only.
Seat belt pre-tensioner assemblies (All applicable locations: buckle, retractor, lap outer)	If either the driver or passenger seat belt pre-tensioner* has been activated: REPLACE all seat belt pre-tensioner assemblies with new fasteners. *: Confirm seat belt pre-tensioner activation using CONSULT only.
Diagnosis sensor unit	If any of the SRS components have been activated: REPLACE the diagnosis sensor unit. Install with new fasteners.
Steering wheel	<ol style="list-style-type: none"> 1. Visually check steering wheel for deformities. 2. Check harness (built into steering wheel) and connectors for damage, and terminals for deformities. 3. Install driver air bag module into the steering wheel to check fit and alignment with the wheel. 4. Check steering wheel for excessive free play. 5. If no damage is found, reinstall. 6. If damaged – REPLACE.
Spiral cable	If the driver front air bag has deployed: REPLACE the spiral cable.
Occupant classification system (Passenger seat)	<ol style="list-style-type: none"> 1. Remove passenger seat assembly. 2. Check control unit case for dents, cracks or deformities. 3. Check connectors and pressure sensor tube for damage, and terminals for deformities. 4. Check seat frame and cushion pan for dents or deformities. 5. If no damage is found, reinstall seat with new fasteners. 6. If damaged – REPLACE seat cushion assembly with new fasteners.

COLLISION DIAGNOSIS

< BASIC INSPECTION >

Part	Inspection
Harness and connectors	<ol style="list-style-type: none"> 1. Check connectors for poor connection, damage, and terminals for deformities. 2. Check harness for binding, chafing, cuts, or deformities. 3. If no damage is found, reinstall the harness and connectors. 4. If damaged – REPLACE the damaged harness. Do not attempt to repair, splice or modify any SRS harness.
Instrument panel assembly	If the passenger air bag has deployed: REPLACE the instrument panel assembly. (integrated type)

FOR FRONTAL COLLISION : When SRS is not activated in a collision

INFOID:000000007095648

CAUTION:

Due to varying models and option levels, not all parts listed in the chart below apply to all vehicles.

WORK PROCEDURE

1. Before performing any of the following steps, ensure that all vehicle body and structural repairs have been completed.
2. Check the SRS components using the table below:
Replace any SRS components showing visible signs of damage. (dents, cracks and deformation, etc.)
3. Perform self-diagnosis using CONSULT or air bag warning lamp. Refer to [SRC-19. "CONSULT Function"](#) or [SRC-15. "On Board Diagnosis Function"](#) for details. Ensure entire SRS operates properly.
4. After the work is completed, perform self-diagnosis to check that no malfunction is detected. Refer to [SRC-15. "Description"](#).

SRS INSPECTION (FOR FRONTAL COLLISION)

Part	Inspection
Driver air bag module	<p>If the driver air bag has NOT been deployed:</p> <ol style="list-style-type: none"> 1. Remove driver air bag module. Check harness cover and connectors for damage, terminals for deformities, and harness for binding. 2. Install driver air bag module into the steering wheel to check fit and alignment with the wheel. 3. If no damage is found, reinstall with new fasteners. 4. If damaged – REPLACE. Install driver air bag module with new fasteners. <p style="color: red; margin-top: 5px;">CAUTION: Before disposing of such systems, deploy the systems.</p>
Passenger air bag module (if equipped)	<p>If the passenger air bag has NOT been deployed:</p> <ol style="list-style-type: none"> 1. Remove passenger air bag module. Check harness cover and connectors for damage, terminals for deformities, and harness for binding. 2. Install passenger air bag module into the instrument panel to check fit with the instrument panel. 3. If no damage is found, reinstall with new fasteners. 4. If damaged – REPLACE. Install passenger air bag modules with new fasteners. <p style="color: red; margin-top: 5px;">CAUTION: Before disposing of such systems, deploy the systems.</p>
Crash zone sensor	<p>If the front air bags or seat belt pre-tensioners have NOT been activated:</p> <ol style="list-style-type: none"> 1. Remove the crash zone sensor. Check harness connectors for damage, terminals for deformities, and harness for binding. 2. Check for visible signs of damage (dents, cracks, deformation, etc.) of the crash zone sensor and bracket. 3. Install the crash zone sensor to check fit. 4. If no damage is found, reinstall with new fasteners. 5. If damaged – REPLACE the crash zone sensor and bracket with new fasteners.

A
B
C
D
E
F
G
SR
I
J
K
L
M
N
O
P

COLLISION DIAGNOSIS

< BASIC INSPECTION >

Part	Inspection
Seat belt pre-tensioner assemblies (All applicable locations: buckle, retractor, lap outer)	<p>If the pre-tensioners have NOT been activated:</p> <ol style="list-style-type: none"> 1. Remove seat belt pre-tensioners. Check harness cover and connectors for damage, terminals for deformities, and harness for binding. 2. Check belts for damage and anchors for loose mounting. 3. Check retractor for smooth operation. 4. Check seat belt adjuster for damage. 5. Check for deformities of the center pillar inner. 6. If the center pillar inner has no damage, REPLACE the seat belt pre-tensioner assembly. 7. If no damage is found, reinstall seat belt pre-tensioner assembly. 8. If damaged – REPLACE. Install the seat belt pre-tensioners with new fasteners. <p>CAUTION: Before disposing of such systems, deploy the systems.</p>
Diagnosis sensor unit	<p>If none of the SRS components have been activated:</p> <ol style="list-style-type: none"> 1. Check case for dents, cracks or deformities. 2. Check connectors for damage, and terminals for deformities. 3. If no damage is found, reinstall with new fasteners. 4. If damaged – REPLACE. Install diagnosis sensor unit with new fasteners.
Steering wheel	<ol style="list-style-type: none"> 1. Visually check steering wheel for deformities. 2. Check harness (built into steering wheel) and connectors for damage, and terminals for deformities. 3. Install driver air bag module into the steering wheel to check fit and alignment with the wheel. 4. Check steering wheel for excessive free play. 5. If no damage is found, reinstall. 6. If damaged – REPLACE.
Spiral cable	<p>If the driver front air bag has not deployed:</p> <ol style="list-style-type: none"> 1. Visually check spiral cable and combination switch for damage. 2. Check connectors and protective tape for damage. 3. Check steering wheel for noise, binding or heavy operation. 4. If no damage is found, reinstall. 5. If damaged – REPLACE.
Occupant classification system (Passenger seat)	<ol style="list-style-type: none"> 1. Remove passenger seat assembly. 2. Check control unit case for dents, cracks or deformities. 3. Check connectors and pressure sensor tube for damage, and terminals for deformities. 4. Check seat frame and cushion pan for dents or deformities. 5. If no damage is found, reinstall seat with new fasteners. 6. If damaged – REPLACE seat cushion assembly with new fasteners.
Harness and connectors	<ol style="list-style-type: none"> 1. Check connectors for poor connection, damage, and terminals for deformities. 2. Check harness for binding, chafing, cuts, or deformities. 3. If no damage is found, reinstall the harness and connectors. 4. If damaged – REPLACE the damaged harness. Do not attempt to repair, splice or modify any SRS harness.
Instrument panel assembly	<p>If the passenger air bag has NOT deployed:</p> <ol style="list-style-type: none"> 1. Visually check instrument panel assembly for damage. 2. If no damage is found, reinstall the instrument panel assembly. 3. If damaged – REPLACE the instrument panel assembly.

FOR SIDE AND ROLLOVER COLLISION

FOR SIDE AND ROLLOVER COLLISION : When SRS is activated in a collision

INFOID:000000007095649

CAUTION:

Due to varying models and option levels, not all parts listed in the chart below apply to all vehicles.

WORK PROCEDURE

1. Before performing any of the following steps, ensure that all vehicle body and structural repairs have been completed.
2. Replace the following components:
 - Front seat back assembly (on the side on which side air bag is activated)
 - Door finisher (on the side on which door-mounted curtain air bag is activated)
 - Pop-up roll bar assemblies and pop-up roll bar covers

COLLISION DIAGNOSIS

< BASIC INSPECTION >

- Satellite sensor LH/RH (on the side on which side air bag is activated)
 - Diagnosis sensor unit
 - Seat belt pre-tensioner assemblies
3. Check the SRS components and the related parts using the following table.
Replace any SRS components and the related parts showing visible signs of damage. (dents, cracks, deformation, etc.)
 4. Perform self-diagnosis using CONSULT and "AIR BAG" warning lamp. Refer to [SRC-19, "CONSULT Function"](#) or [SRC-15, "On Board Diagnosis Function"](#) for details. Make sure entire SRS operates properly.
 5. After the work is completed, perform self-diagnosis to check that no malfunction is detected. Refer to [SRC-15, "Description"](#).

SRS INSPECTION (FOR SIDE AND ROLLOVER COLLISION)

Part	Inspection
Curtain air bag module LH	If the curtain air bag LH has deployed: REPLACE the curtain air bag module LH. Install with new fasteners.
Curtain air bag module RH	If the curtain air bag RH has deployed: REPLACE the curtain air bag module RH. Install with new fasteners.
Side air bag module LH	If the side air bag LH has deployed: REPLACE front seatback assembly LH.
Side air bag module RH	If the side air bag RH has deployed: REPLACE front seatback assembly RH.
Satellite sensor (LH or RH)	If any of the SRS components have deployed: REPLACE the satellite sensor on the collision side with new fasteners.
Diagnosis sensor unit	If any of the SRS components have deployed: REPLACE the diagnosis sensor unit with new fasteners.
Seat belt pre-tensioner assemblies (All applicable locations: buckle, retractor, lap outer)	If either the driver or passenger seat belt pre-tensioner* has been activated: REPLACE all seat belt pre-tensioner assemblies with new fasteners. *: Confirm seat belt pre-tensioner activation using CONSULT only.
Center inner pillar	1. Check the center inner pillar on the collision side for damage (dents, cracks, deformation, etc.). 2. If damaged – REPAIR the center inner pillar.
Trim/headlining	1. Check for visible signs of damage (dents, cracks, deformation, etc.) of the interior trim on the collision side. 2. If damaged – REPLACE the damaged trim parts.
Door-mounted curtain air bag module LH	If the door-mounted curtain air bag module LH has deployed: REPLACE the door finisher LH and door-mounted curtain air bag module. Install with new fasteners.
Door-mounted curtain air bag module RH	If the door-mounted curtain air bag module RH has deployed: REPLACE the door finisher RH and door-mounted curtain air bag module. Install with new fasteners.
Pop-up roll bar assemblies	If the pop-up roll bar has deployed: REPLACE pop-up roll bar assemblies and pop-up roll bar covers. Install with new fasteners.

FOR SIDE AND ROLLOVER COLLISION : When SRS is not activated in a collision

INFOID:000000007095650

CAUTION:

Due to varying models and option levels, not all parts listed in the chart below apply to all vehicles.

WORK PROCEDURE

1. Before performing any of the following steps, ensure that all vehicle body and structural repairs have been completed.
2. Check the SRS components and the related parts using the following table.
 - If the front seat back assembly is damaged, the front seat back assembly must be replaced.

COLLISION DIAGNOSIS

< BASIC INSPECTION >

- If the door finisher assembly is damaged, the door finisher assembly and door-mounted curtain air bag module must be replaced.
3. Perform self-diagnosis using CONSULT and "AIR BAG" warning lamp. Refer to [SRC-19. "CONSULT Function"](#) or [SRC-15. "On Board Diagnosis Function"](#) for details. Make sure entire SRS operates properly.
 4. After the work is completed, perform self-diagnosis to check that no malfunction is detected. Refer to [SRC-15. "Description"](#).

SRS INSPECTION (FOR SIDE AND ROLLOVER COLLISION)

Part	Inspection
Curtain air bag module LH	<p>If the curtain air bag LH has NOT deployed:</p> <ol style="list-style-type: none"> 1. Check for visible signs of damage (dents, tears, deformation, etc.) of the center pillar on the collision side. 2. If damaged – Remove the curtain air bag module LH. 3. Check for visible signs of damage (tears etc.) of the curtain air bag module LH. 4. Check harness and connectors for damage, and terminals for deformities. 5. If no damage is found, reinstall the curtain air bag module LH with new fasteners. 6. If damaged – REPLACE the curtain air bag module LH with new fasteners. <p>CAUTION: Before disposing of such systems, deploy the systems.</p>
Curtain air bag module RH	<p>If the curtain air bag RH has NOT deployed:</p> <ol style="list-style-type: none"> 1. Check for visible signs of damage (dents, tears, deformation, etc.) of the center pillar on the collision side. 2. If damaged – Remove the curtain air bag module RH. 3. Check for visible signs of damage (tears etc.) of the curtain air bag module RH. 4. Check harness and connectors for damage, and terminals for deformities. 5. If no damage is found, reinstall the curtain air bag module RH with new fasteners. 6. If damaged – REPLACE the curtain air bag module RH with new fasteners. <p>CAUTION: Before disposing of such systems, deploy the systems.</p>
Side air bag module LH	<p>If the side air bag LH has NOT deployed:</p> <ol style="list-style-type: none"> 1. Check for visible signs of damage (dents, tears, deformation, etc.) of the seat back on the collision side. 2. Check harness and connectors for damage, and terminals for deformities. 3. If damaged – REPLACE the front seatback assembly LH. <p>CAUTION: Before disposing of such systems, deploy the systems.</p>
Side air bag module RH	<p>If the side air bag RH has NOT deployed:</p> <ol style="list-style-type: none"> 1. Check for visible signs of damage (dents, tears, deformation, etc.) of the seat back on the collision side. 2. Check harness and connectors for damage, and terminals for deformities. 3. If damaged – REPLACE the front seatback assembly RH. <p>CAUTION: Before disposing of such systems, deploy the systems.</p>
Satellite sensor (LH or RH)	<p>If none of the SRS components have been activated:</p> <ol style="list-style-type: none"> 1. Remove the satellite sensor (LH or RH) on the collision side. Check harness connectors for damage, terminals for deformities, and harness for binding. 2. Check for visible signs of damage (dents, cracks, deformation, etc.) of the satellite sensor (LH or RH). 3. Install the satellite sensor (LH or RH) to check fit. 4. If no damage is found, reinstall the side air bag (satellite) sensor (LH or RH) with new fasteners. 5. If damaged – REPLACE the satellite sensor (LH or RH) with new fasteners.
Diagnosis sensor unit	<p>If none of the SRS components have been activated:</p> <ol style="list-style-type: none"> 1. Check case and bracket for dents, cracks or deformities. 2. Check connectors for damage, and terminals for deformities. 3. If no damage is found, reinstall the diagnosis sensor unit with new fasteners. 4. If damaged – REPLACE the diagnosis sensor unit with new fasteners.

COLLISION DIAGNOSIS

< BASIC INSPECTION >

Part	Inspection	
Seat belt pre-tensioner assemblies (All applicable locations: buckle, retractor, lap outer)	<p>If the pre-tensioners have NOT been activated:</p> <ol style="list-style-type: none"> 1. Remove seat belt pre-tensioners. Check harness cover and connectors for damage, terminals for deformities, and harness for binding. 2. Check belts for damage and anchors for loose mounting. 3. Check retractor for smooth operation. 4. Check seat belt adjuster for damage. 5. Check for deformities of the center pillar inner. 6. If the center pillar inner has no damage, REPLACE the seat belt pre-tensioner assembly. 7. If no damage is found, reinstall seat belt pre-tensioner assembly. 8. If damaged – REPLACE. Install the seat belt pre-tensioners with new fasteners. <p>CAUTION: Before disposing of such systems, deploy the systems.</p>	A B C D
Seat (with side air bag)	<p>If the front LH or front RH side air bag modules have NOT deployed:</p> <ol style="list-style-type: none"> 1. Visually check the seat on the collision side. 2. Remove the seat on the collision side and check the following for damage and deformities. <ul style="list-style-type: none"> - Harness, connectors and terminals - Frame and recliner (for front and rear seat), and also adjuster and slides (for front seat) 3. If no damage is found, reinstall the seat. 4. If damaged – REPLACE the damaged seat parts using new fasteners. If the front seat back is damaged, the front seat back assembly must be replaced. 	E F
Center inner pillar	<ol style="list-style-type: none"> 1. Check the center inner pillar on the collision side for damage (dents, cracks, deformation, etc.). 2. If damaged – REPAIR the center inner pillar. 	G
Trim/headlining	<ol style="list-style-type: none"> 1. Check for visible signs of damage (dents, cracks, deformation, etc.) of the interior trim on the collision side. 2. If damaged – REPLACE the damaged trim parts. 	SR
Door-mounted curtain air bag module LH	<p>If the door-mounted curtain air bag LH has NOT deployed:</p> <ol style="list-style-type: none"> 1. Check for visible signs of damage (dents, tears, deformation, etc.) of the door finisher on the collision side. 2. If damaged – REPLACE the door finisher LH with new fasteners. 3. Check for visible signs of damaged (tears etc.) of the door-mounted curtain air bag module LH. 4. Check harness and connectors for damage, and terminals for deformities. 5. If no damage is found, reinstall door finisher. <p>CAUTION: When removing door-mounted curtain air bag module from door finisher, never reuse door finisher.</p> <ol style="list-style-type: none"> 6. If damaged – REPLACE the door finisher LH and door-mounted curtain air bag module LH with new fasteners. <p>CAUTION: Before disposing of such systems, deploy the systems.</p>	I J K L

M
N
O
P

COLLISION DIAGNOSIS

< BASIC INSPECTION >

Part	Inspection
Door-mounted curtain air bag module RH	<p>If the door-mounted curtain air bag RH has NOT deployed:</p> <ol style="list-style-type: none"> 1. Check for visible signs of damage (dents, tears, deformation, etc.) of the door finisher on the collision side. 2. If damaged – REPLACE the door finisher RH with new fasteners. 3. Check for visible signs of damage (tears etc.) of the door-mounted curtain air bag module RH. 4. Check harness and connectors for damage, and terminals for deformities. 5. If no damage is found, reinstall door finisher. CAUTION: When removing door-mounted curtain air bag module from door finisher, never reuse door finisher. 6. If damaged – REPLACE the door finisher RH and door-mounted curtain air bag module RH with new fasteners. CAUTION: Before disposing of such systems, deploy the systems.
Pop-up roll bar	<p>If the pop-up roll bar has NOT deployed:</p> <ol style="list-style-type: none"> 1. Check for visible signs of damage (dents, tears, deformation, etc.) of the pop-up roll bar. 2. If damaged – REPLACE the pop-up roll bar with new fasteners. 3. Check harness and connectors for damage, and terminals for deformities. 4. If no damage is found, reinstall the pop-up roll bar with new fasteners. 5. Check for visible signs of damage (dents, cracks, deformation, etc.) of the seatback support brace assembly. 6. If damaged – REPAIR the seatback support brace assembly. CAUTION: Before disposing of such systems, deploy the systems.

DRIVER AIR BAG MODULE

< REMOVAL AND INSTALLATION >

REMOVAL AND INSTALLATION

DRIVER AIR BAG MODULE

Exploded View

INFOID:000000007095651

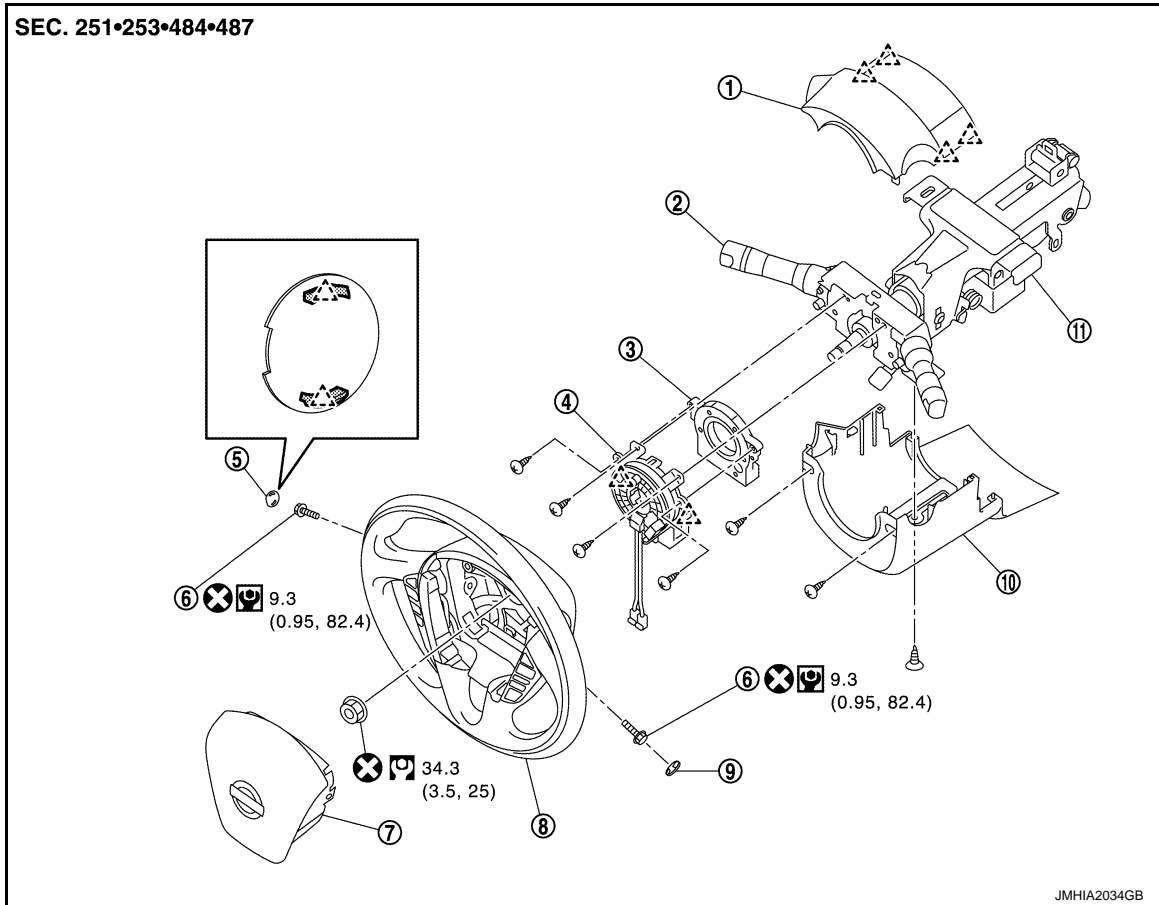

- | | | |
|---------------------------------|------------------------------|--------------------------|
| 1. Steering column upper cover | 2. Combination switch | 3. Steering angle sensor |
| 4. Spiral cable | 5. Side lid LH | 6. TORX bolt |
| 7. Driver air bag module | 8. Steering wheel | 9. Side lid RH |
| 10. Steering column lower cover | 11. Steering column assembly | |

 : Pawl

 : Always replace after every disassembly.

 : N-m (kg-m, in-lb)

 : N-m (kg-m, ft-lb)

Removal and Installation

INFOID:000000007095652

WARNING:

Always observe the following items for preventing accidental activation.

- Before servicing, turn ignition switch OFF, disconnect battery negative terminal and wait for 3 minutes or more.
- Always work from the side of air bag module. Never work in front of it.
- Never use air tools or electric tools for servicing.

REMOVAL

1. Remove side lid (LH and RH).

DRIVER AIR BAG MODULE

< REMOVAL AND INSTALLATION >

Insert flat-bladed screwdriver between side lid and steering wheel to disengage pawls as shown in the figure.

 : Pawl

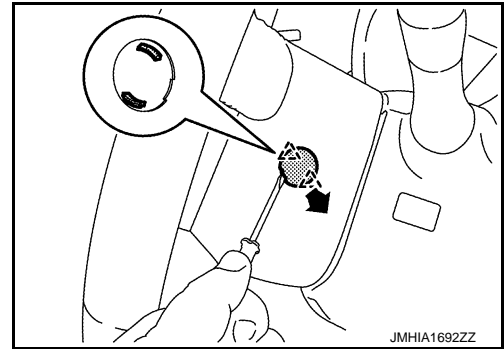

2. Remove TORX bolts (LH and RH) from the steering wheel lower side using TORX bit.
3. Pull out driver air bag module (A).
4. Disconnect driver air bag harness connectors (B).

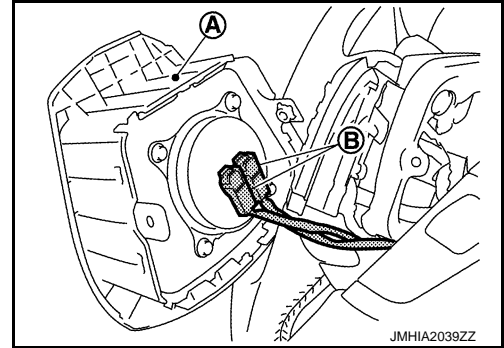

CAUTION:

- For installing/removing the driver air bag module harness connector, insert a thin screwdriver wrapped in tape into notch, lift lock and remove the connector.
- Install the connector with lock raised, and push lock into the connector.
- After installing the connector, check that the lock is pushed securely into it.

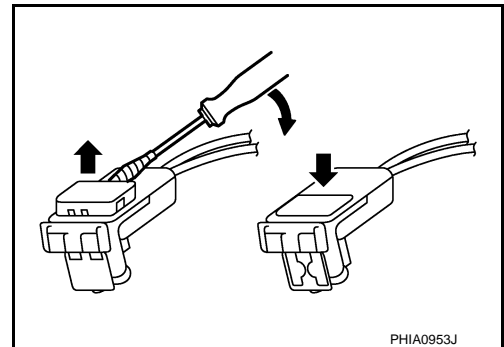

5. Remove driver air bag module.

CAUTION:

- To prevent accidental explosion, always place the driver air bag module with pad side facing upward.

 : Upward

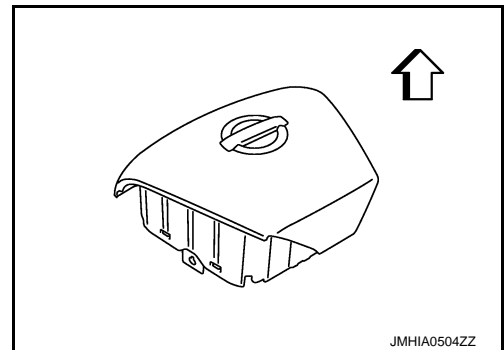

DRIVER AIR BAG MODULE

< REMOVAL AND INSTALLATION >

- To prevent damage to the parts, never impact the driver air bag module.
- Replace the driver air bag module if it is dropped or sustains an impact.



- To prevent accidental explosion, never insert any foreign objects (screwdriver, etc.) into the driver air bag module.
- To prevent accidental explosion, never disassemble the driver air bag module.
- To prevent accidental explosion, never expose the driver air bag module to temperatures of more than 90 °C (194 °F).
- To prevent accidental explosion, never allow oil, grease, detergent, or water to come in contact with the driver air bag module.

INSTALLATION

Note the following items, and then install in the reverse order of removal.

CAUTION:

- Never reuse mounting TORX bolts after removal, replace with new TORX bolts.
- Fix the driver air bag module harnesses (A) to the harness fixing hook (B).

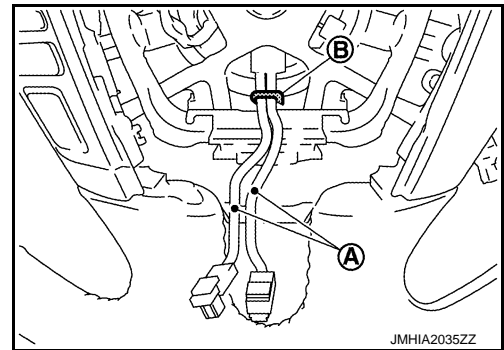

- Never damage the harness while installing.
- Tighten the TORX bolts after completely adjusting the centers of fixing holes on the driver air bag module side and the steering wheel side. If the holes are misaligned, the bolt threads are damaged and the module is not installed securely.
- If malfunction is detected by the air bag warning lamp, after repair or replacement of the malfunctioning parts, reset the memory using self-diagnosis or CONSULT. Refer to [SRC-15, "On Board Diagnosis Function"](#) or [SRC-19, "CONSULT Function"](#).
- After the work is complete, check that no system malfunction is detected by air bag warning lamp.

SPIRAL CABLE

< REMOVAL AND INSTALLATION >

SPIRAL CABLE

Exploded View

INFOID:000000007095905

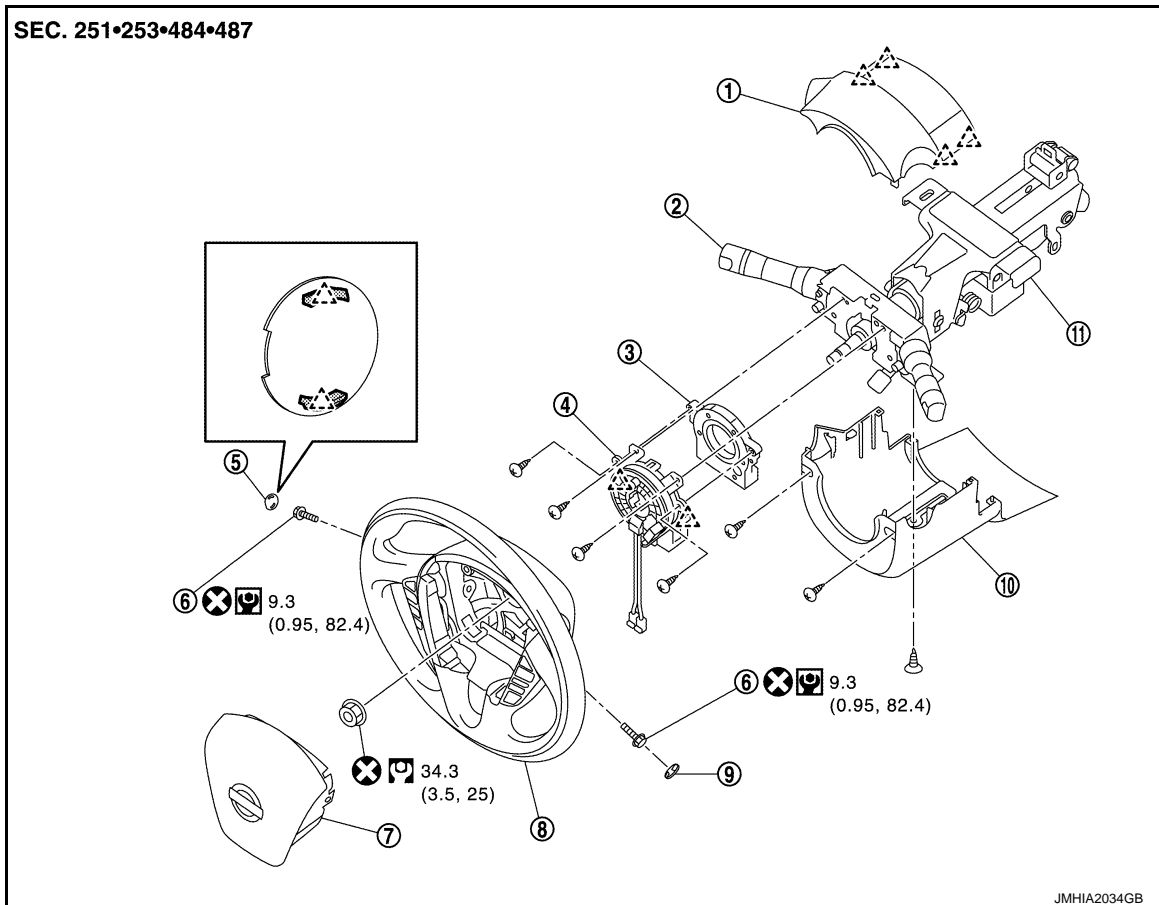

- | | | |
|---------------------------------|------------------------------|--------------------------|
| 1. Steering column upper cover | 2. Combination switch | 3. Steering angle sensor |
| 4. Spiral cable | 5. Side lid LH | 6. TORX bolt |
| 7. Driver air bag module | 8. Steering wheel | 9. Side lid RH |
| 10. Steering column lower cover | 11. Steering column assembly | |

△ : Pawl

⊗ : Always replace after every disassembly.

Ⓜ : N·m (kg·m, in·lb)

Ⓜ : N·m (kg·m, ft·lb)

Removal and Installation

INFOID:000000007095654

WARNING:

Always observe the following items for preventing accidental activation.

- Before servicing, turn ignition switch OFF, disconnect battery negative terminal and wait for 3 minutes or more.
- Never use air tools or electric tools for servicing.

REMOVAL

1. Remove driver air bag module. Refer to [SR-11, "Removal and Installation"](#).
2. Remove steering wheel. Refer to [ST-11, "Removal and Installation"](#).
3. Remove steering column upper cover and steering column lower cover. Refer to [IP-13, "Removal and Installation"](#).

SPIRAL CABLE

< REMOVAL AND INSTALLATION >

4. Disconnect the spiral cable body side harness connectors (A), (B) and steering angle sensor harness connector (C).

NOTE:

Disconnect the spiral cable body side harness connector (B) after removing the spiral cable body side harness connector (A).

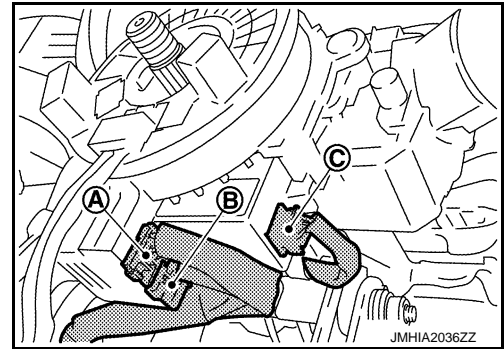

5. Remove the spiral cable fixing screws.
6. Remove the spiral cable fixing pawls with remover tool (A), then remove the spiral cable.

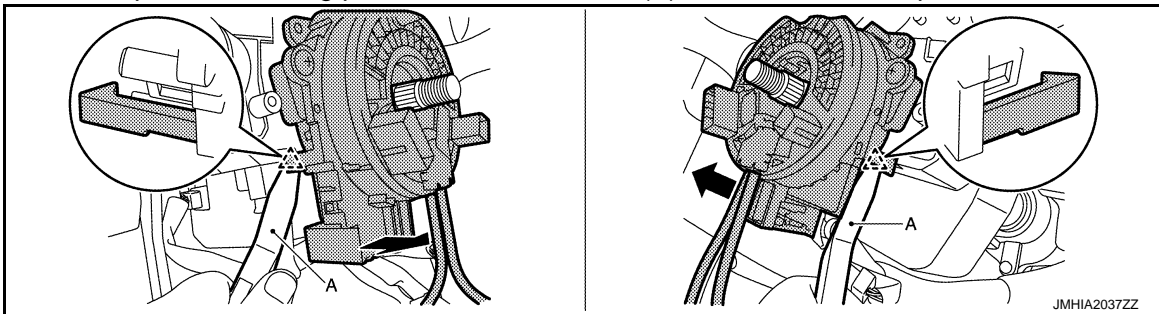

 : Pawl

CAUTION:

Remove pawls slowly so that they are not damaged.

7. Remove the steering angle sensor. Refer to [BRC-125. "Removal and Installation"](#).

CAUTION:

- To prevent damage to the parts, never impact the spiral cable.
- Replace the spiral cable if it is dropped or sustains an impact.



- To prevent damage to the parts, never disassemble the spiral cable.
- To prevent damage to the parts, never apply lubricant to the spiral cable.
- To prevent damage to the parts, never allow oil, grease, detergent, or water to come in contact with the spiral cable.

INSTALLATION

Note the following items, and then install in the reverse order of removal.

CAUTION:

SPIRAL CABLE

< REMOVAL AND INSTALLATION >

- The spiral cable may snap during steering operation if the cable is installed in an improper position. The neutral position is set as per the following.
- Carefully turn the spiral cable clockwise to the end position. Then turn it counterclockwise (about 2 and a half turns) and stop turning at the mark (B) when the stopper insertion holes are in the same position.
- The service part is installed in the neutral position by the stopper and can be set without adjusting after the stopper is removed.
- Never over turn the spiral cable or go beyond the number of turns required. (This causes the cable to snap)
- Adjust the spiral cable locating pin (A) to the steering wheel locating pin hole (C).

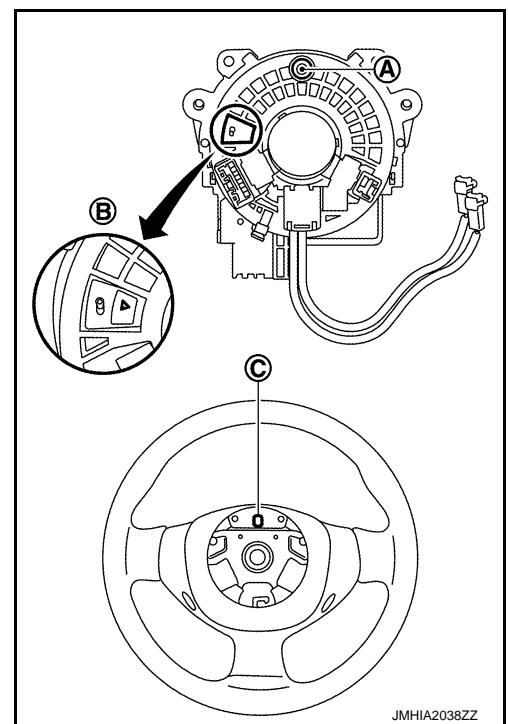

JMHIA2038ZZ

- Fix the driver air bag module harnesses (A) to the harness fixing hook (B).

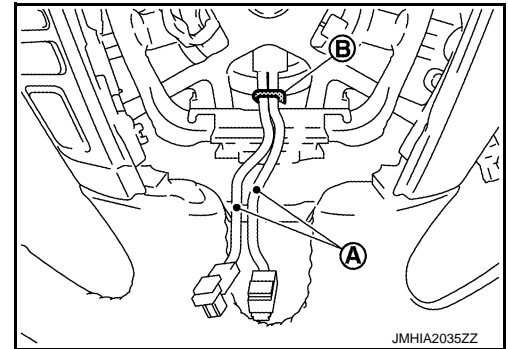

JMHIA2035ZZ

- If malfunction is detected by the air bag warning lamp, after repair or replacement of the malfunctioning parts, reset the memory using self-diagnosis or CONSULT. Refer to [SRC-15. "On Board Diagnosis Function"](#) or [SRC-19. "CONSULT Function"](#).
- After the work is completed, check that no system malfunction is detected by air bag warning lamp.

PASSENGER AIR BAG MODULE

< REMOVAL AND INSTALLATION >

PASSENGER AIR BAG MODULE

Exploded View

INFOID:000000007095655

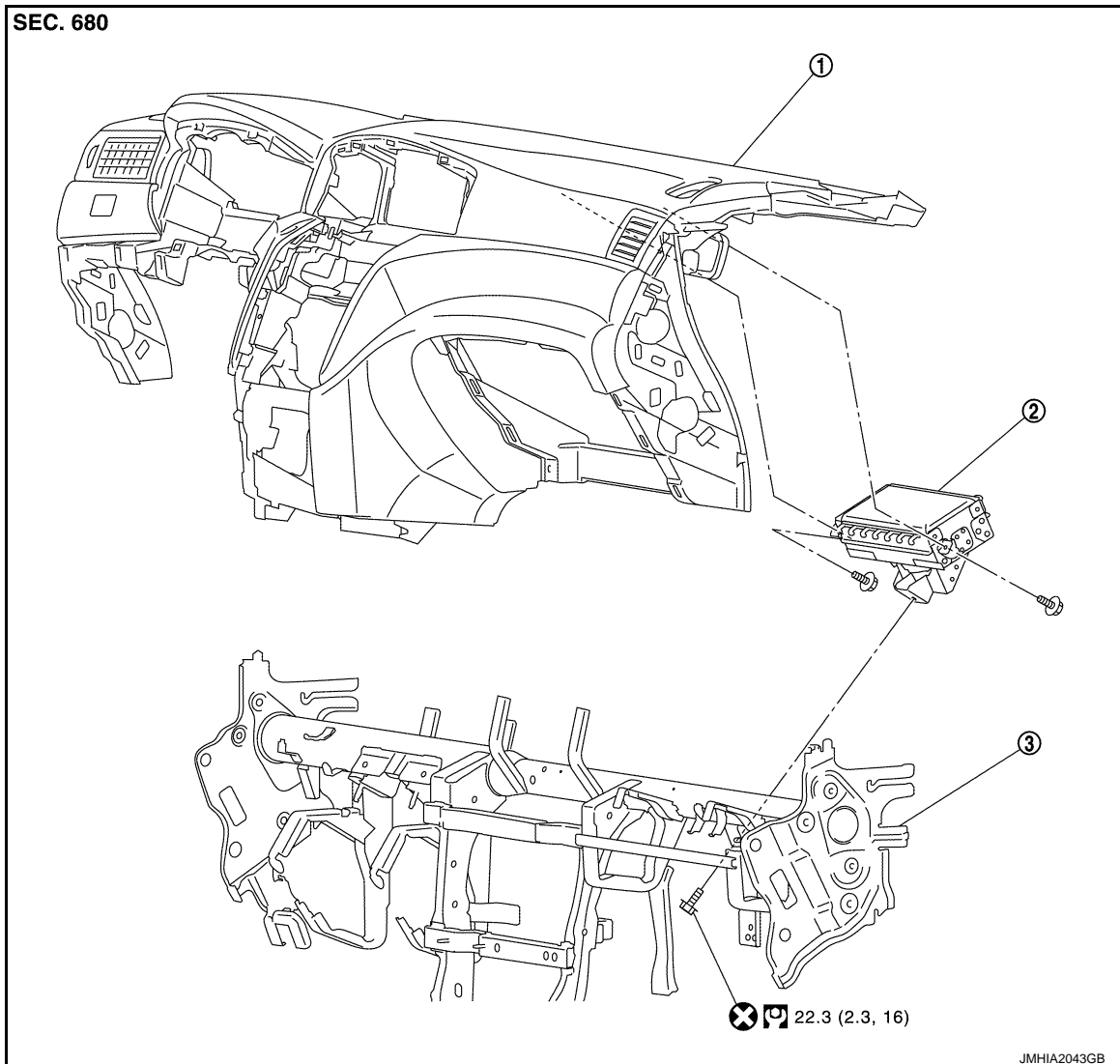

1. Instrument panel assembly 2. Passenger air bag module 3. Steering member assembly

⊗ : Always replace after every disassembly.

⊞ : N·m (kg-m, ft-lb)

Removal and Installation

INFOID:000000007095656

WARNING:

Always observe the following items for preventing accidental activation.

- Before servicing, turn ignition switch OFF, disconnect battery negative terminal and wait for 3 minutes or more.
- Always work from the side of air bag module. Never work in front of it.
- Never use air tools or electric tools for servicing.

REMOVAL

1. Remove instrument panel assembly. Refer to [IP-13, "Removal and Installation"](#).

PASSENGER AIR BAG MODULE

< REMOVAL AND INSTALLATION >

2. Remove passenger air bag module fixing screws (A).

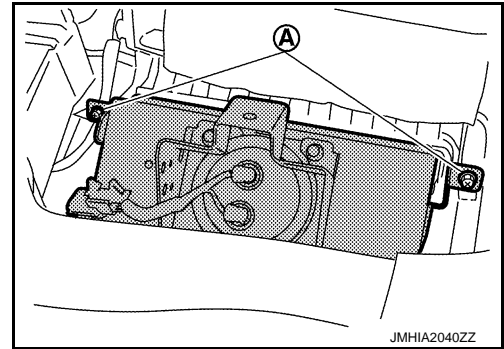

3. Pull up air bag grid portion of instrument panel, and then disengage the passenger air bag module.
4. Remove passenger air bag module from instrument panel.

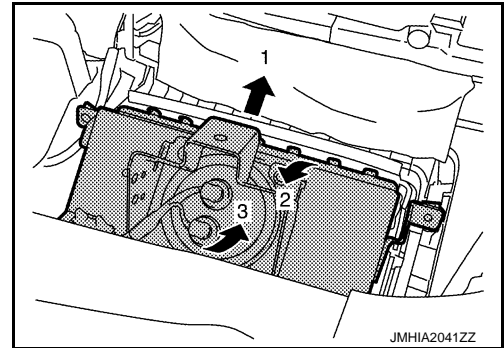

CAUTION:

- To prevent accidental explosion, always place the passenger air bag module with pad side facing upward.

↕ : Upward

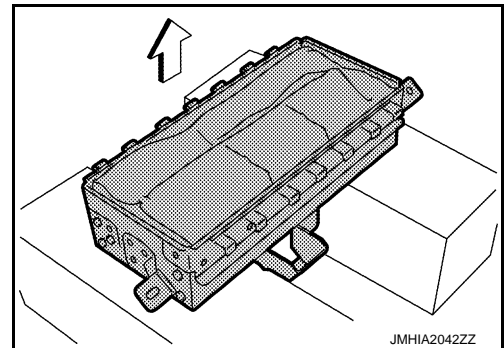

- To prevent damage to the parts, never impact the passenger air bag module.
- Replace the passenger air bag module if it is dropped or sustains an impact.



- To prevent accidental explosion, never insert any foreign objects (screwdriver, etc.) into the passenger air bag module.
- To prevent accidental explosion, never disassemble the passenger air bag module.
- To prevent accidental explosion, never expose the passenger air bag module to temperatures of more than 90 °C (194 °F).
- To prevent damage to the parts, never allow oil, grease, detergent, or water to come in contact with the passenger air bag module.

INSTALLATION

Note the following items, and then install in the reverse order of removal.

PASSENGER AIR BAG MODULE

< REMOVAL AND INSTALLATION >

CAUTION:

- Never reuse mounting bolts after removal, replace with new bolts.
- Never damage the harness while installing.
- If malfunction is detected by the air bag warning lamp, after repair or replacement of the malfunctioning parts, reset the memory using self-diagnosis or CONSULT. Refer to [SRC-15, "On Board Diagnosis Function"](#) or [SRC-19, "CONSULT Function"](#).
- After the work is completed, check that no system malfunction is detected by air bag warning lamp.

A
B
C
D
E
F
G
SR
I
J
K
L
M
N
O
P

SR

CURTAIN AIR BAG MODULE

< REMOVAL AND INSTALLATION >

CURTAIN AIR BAG MODULE

Exploded View

INFOID:000000007095657

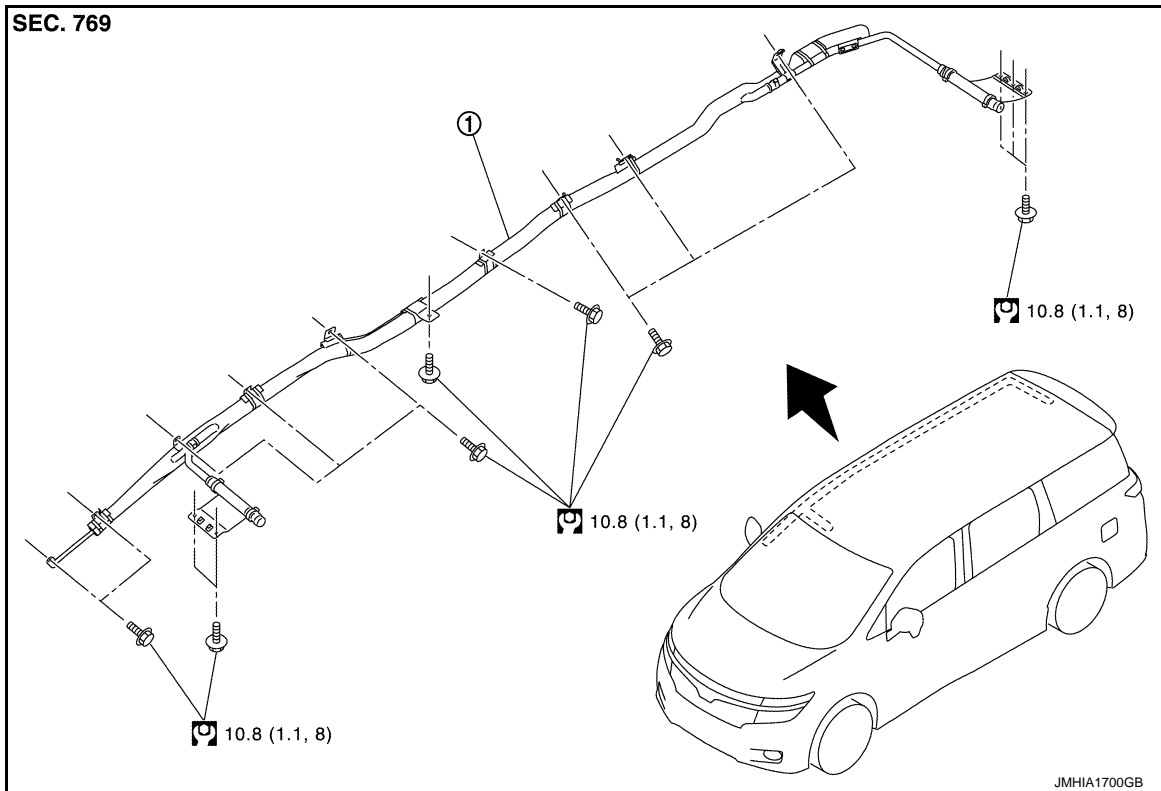

1. Curtain air bag module

 : N·m (kg-m, ft-lb)

Removal and Installation

INFOID:000000007095658

WARNING:

Always observe the following items for preventing accidental activation.

- Before servicing, turn ignition switch OFF, disconnect battery negative terminal and wait for 3 minutes or more.
- Always work from the side of curtain air bag module. Never work in front of it.
- Never use air tools or electric tools for servicing.

REMOVAL

1. Remove headlining assembly. Refer to [INT-34, "Removal and Installation"](#).
2. Disconnect the curtain air bag harness connector (front and rear).

CAUTION:

- For installing/removing the curtain air bag harness connector, insert a thin screwdriver wrapped in tape into notch, lift lock and remove the connector.
- Install the connector with lock raised, and push lock into the connector.
- After installing the connector, check that the lock is pushed securely into it.

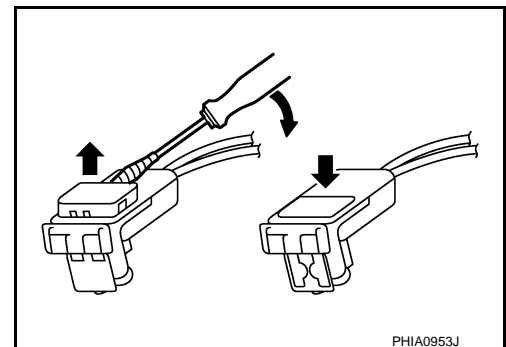

CURTAIN AIR BAG MODULE

< REMOVAL AND INSTALLATION >

3. Remove mounting bolts, and then remove the curtain air bag module.

CAUTION:

- To prevent damage to the parts, never impact the curtain air bag module.
- Replace the curtain air bag module if it is dropped or sustains an impact.



- To prevent accidental explosion, never insert any foreign objects (screwdriver, etc.) into the curtain air bag module.
- To prevent accidental explosion, never disassemble the curtain air bag module.
- To prevent accidental explosion, never expose the curtain air bag module to temperatures of more than 90 °C (194 °F).
- To prevent damage to the parts, never allow oil, grease, detergent, or water to come in contact with the curtain air bag module.

INSTALLATION

Note the following items, and then install in the reverse order of removal.

CAUTION:

- Check perforation of curtain air bag module to check that curtain air bag module is not twisted.
- Never damage the harness while installing.
- If malfunction is detected by the air bag warning lamp, after repair or replacement of the malfunctioning parts, reset the memory using self-diagnosis or CONSULT. Refer to [SRC-15, "On Board Diagnosis Function"](#) or [SRC-19, "CONSULT Function"](#).
- After the work is completed, check that no system malfunction is detected by air bag warning lamp.

A
B
C
D
E
F
G
SR
I
J
K
L
M
N
O
P

CRASH ZONE SENSOR

< REMOVAL AND INSTALLATION >

CRASH ZONE SENSOR

Exploded View

INFOID:000000007095659

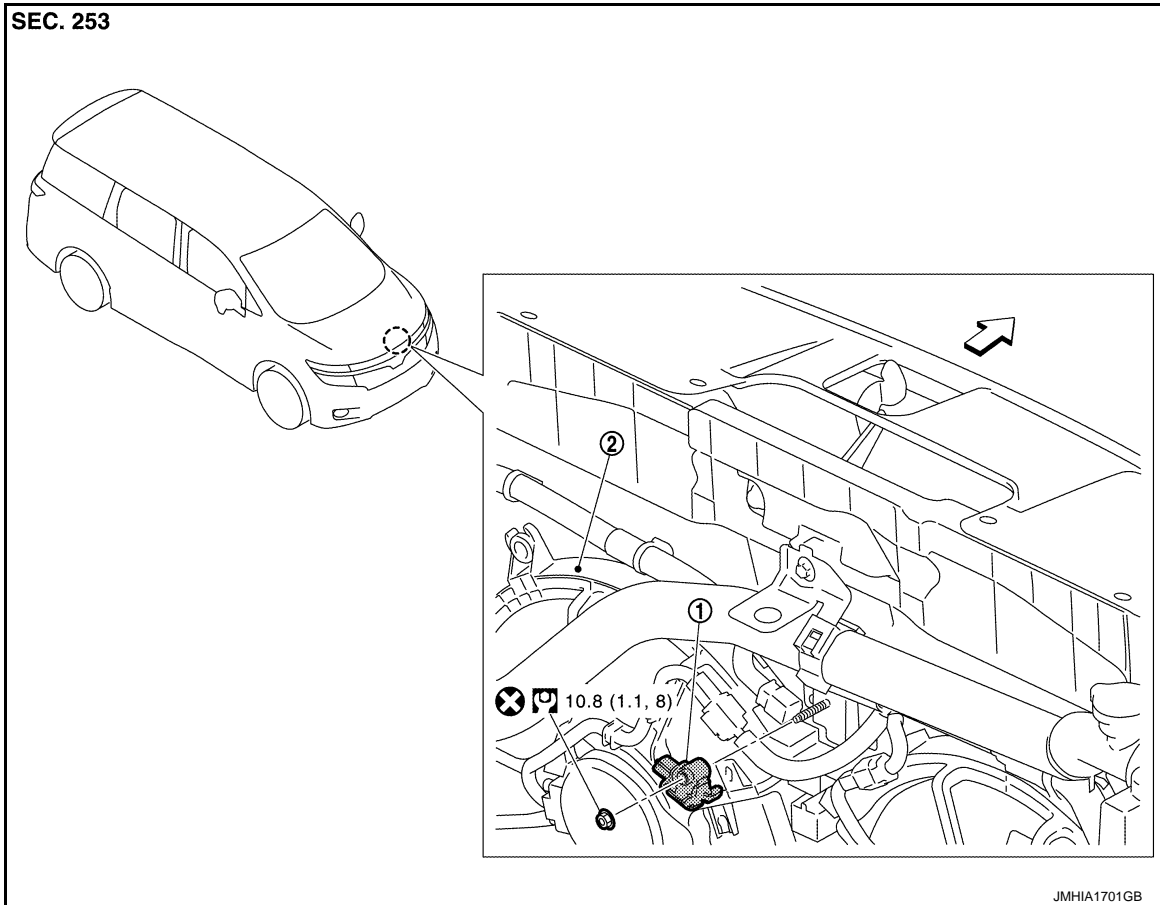

1. Crash zone sensor 2. Cooling fan assembly

↔ : Vehicle front

⊗ : Always replace after every disassembly.

⊞ : N·m (kg·m, ft·lb)

Removal and Installation

INFOID:000000007095660

WARNING:

Always observe the following items for preventing accidental activation.

- Before servicing, turn ignition switch OFF, disconnect battery negative terminal and wait for 3 minutes or more.
- Never use air tools or electric tools for servicing.

REMOVAL

1. Remove air duct (inlet). Refer to [EM-26, "Removal and Installation"](#).

CRASH ZONE SENSOR

< REMOVAL AND INSTALLATION >

2. Remove mounting nut (A), and then pull out the crash zone sensor.
3. Disconnect the harness connector (B), and then remove the crash zone sensor.

← : Vehicle front

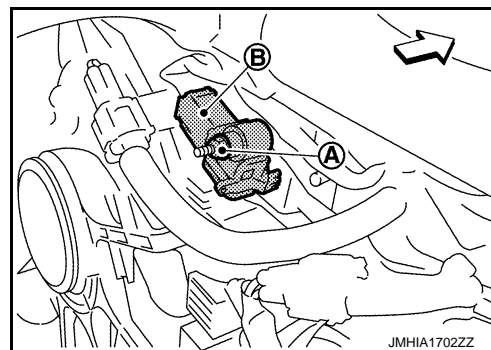

CAUTION:

- To prevent damage to the parts, never impact the crash zone sensor.
- Replace the crash zone sensor if it is dropped or sustains an impact.



- Replace the crash zone sensor of deployed driver air bag, deployed passenger air bag, seat belt pre-tensioner and deployed lap pre-tensioner.

INSTALLATION

Note the following items, and then install in the reverse order of removal.

CAUTION:

- Never reuse mounting nut after removal, replace with new nut.
- Never damage the harness while installing.
- Always install normally aligning to the cutout hole, because performance of the crash zone sensor excessively fluctuates according to the installation position.
- If malfunction is detected by the air bag warning lamp, after repair or replacement of the malfunctioning parts, reset the memory using self-diagnosis or CONSULT. Refer to [SRC-15, "On Board Diagnosis Function"](#) or [SRC-19, "CONSULT Function"](#).
- After the work is completed, check that no system malfunction is detected by air bag warning lamp.

A
B
C
D
E
F
G
SR
I
J
K
L
M
N
O
P

SATELLITE SENSOR

< REMOVAL AND INSTALLATION >

SATELLITE SENSOR

Exploded View

INFOID:000000007095661

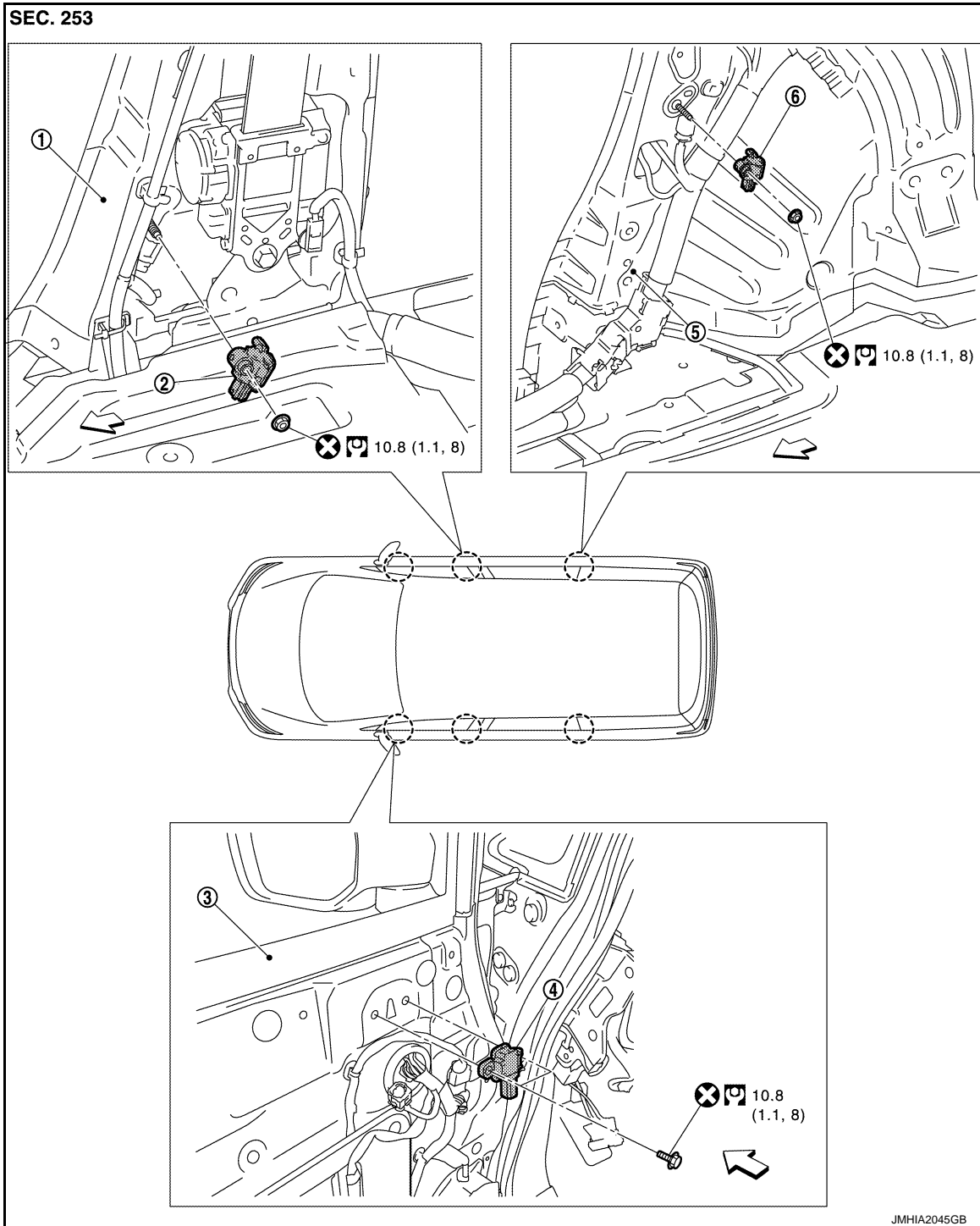

- | | | |
|--------------------------------|---------------------------------|---------------------------|
| 1. Center pillar outer panel | 2. Front satellite sensor | 3. Front door inner panel |
| 4. Front door satellite sensor | 5. Rear wheel house inner panel | 6. Rear satellite sensor |

↔ : Vehicle front

⊗ : Always replace after every disassembly.

Ⓜ : N-m (kg-m, ft-lb)

SATELLITE SENSOR

< REMOVAL AND INSTALLATION >

Removal and Installation

INFOID:000000007095662

WARNING:

Always observe the following items for preventing accidental activation.

- Before servicing, turn ignition switch OFF, disconnect battery negative terminal and wait for 3 minutes or more.
- Never use air tools or electric tools for servicing.

FRONT DOOR SATELLITE SENSOR

Removal

1. Remove the front door finisher. Refer to [INT-13, "Removal and Installation"](#).
2. Remove mounting bolt (A), and then pull out the front door satellite sensor.
3. Disconnect the harness connector (B), and then remove the front satellite sensor.

← : Vehicle front

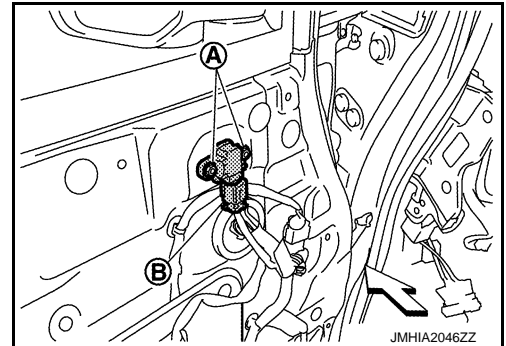

CAUTION:

- To prevent damage to the parts, never impact the front door satellite sensor.
- Replace the front door satellite sensor if it is dropped or sustains an impact.



- Replace the front door satellite sensor of deployed side air bag module and deployed curtain air bag module.

Installation

Note the following items, and then install in the reverse order of removal.

CAUTION:

- Never reuse mounting bolts after removal, replace with new bolts.
- Never damage the harness while installing.
- Always install normally aligning to the cutout hole, because performance of the front door satellite sensor excessively fluctuates according to the installation position.
- If malfunction is detected by the air bag warning lamp, after repair or replacement of the malfunctioning parts, reset the memory using self-diagnosis or CONSULT. Refer to [SRC-15, "On Board Diagnosis Function"](#) or [SRC-19, "CONSULT Function"](#).
- After the work is completed, check that no system malfunction is detected by air bag warning lamp.

FRONT SATELLITE SENSOR

Removal

1. Remove center pillar lower garnish. Refer to [INT-24, "CENTER PILLAR LOWER GARNISH : Removal and Installation"](#).

SATELLITE SENSOR

< REMOVAL AND INSTALLATION >

2. Remove mounting nut (A), and then pull out the front satellite sensor.
3. Disconnect the harness connector (B), and then remove the front satellite sensor.

⇐ : Vehicle front

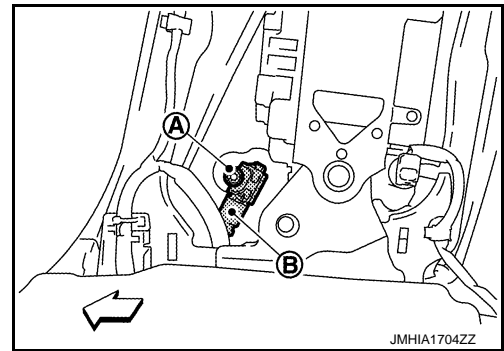

CAUTION:

- To prevent damage to the parts, never impact the front satellite sensor.
- Replace the front satellite sensor if it is dropped or sustains an impact.



- Replace the front satellite sensor of deployed side air bag module and deployed curtain air bag module.

Installation

Note the following items, and then install in the reverse order of removal.

CAUTION:

- Never reuse mounting nut after removal, replace with new nut.
- Never damage the harness while installing.
- Always install normally aligning to the cutout hole, because performance of the front satellite sensor excessively fluctuates according to the installation position.
- If malfunction is detected by the air bag warning lamp, after repair or replacement of the malfunctioning parts, reset the memory using self-diagnosis or CONSULT. Refer to [SRC-15, "On Board Diagnosis Function"](#) or [SRC-19, "CONSULT Function"](#).
- After the work is completed, check that no system malfunction is detected by air bag warning lamp.

REAR SATELLITE SENSOR

Removal

1. Remove luggage side lower finisher. Refer to [INT-42, "LUGGAGE SIDE LOWER FINISHER : Removal and Installation"](#).
2. Remove mounting nut (A), and then pull out the rear satellite sensor.
3. Disconnect the harness connector (B), and then remove rear satellite sensor.

⇐ : Vehicle front

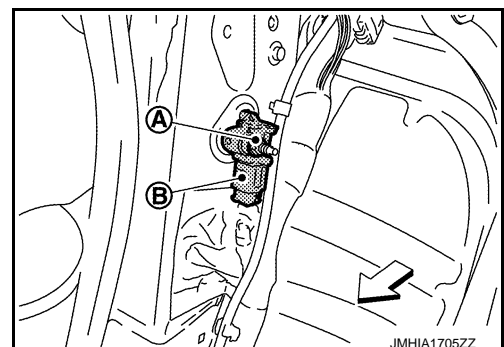

CAUTION:

SATELLITE SENSOR

< REMOVAL AND INSTALLATION >

- To prevent damage to the parts, never impact the rear satellite sensor.
- Replace the rear satellite sensor if it is dropped or sustains an impact.

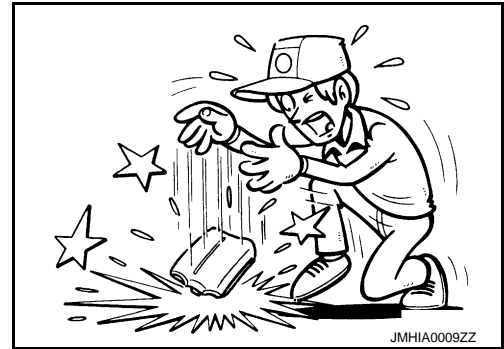

- Replace the rear satellite sensor of deployed side air bag module and deployed curtain air bag module.

Installation

Note the following items, and then install in the reverse order of removal.

CAUTION:

- Never reuse mounting nut after removal, replace with new nut.
- Never damage the harness while installing.
- Always install normally aligning to the cutout hole, because performance of the rear satellite sensor excessively fluctuates according to the installation position.
- If malfunction is detected by the air bag warning lamp, after repair or replacement of the malfunctioning parts, reset the memory using self-diagnosis or CONSULT. Refer to [SRC-15. "On Board Diagnosis Function"](#) or [SRC-19. "CONSULT Function"](#).
- After the work is completed, check that no system malfunction is detected by air bag warning lamp.

A
B
C
D
E
F
G
SR
I
J
K
L
M
N
O
P

DIAGNOSIS SENSOR UNIT

< REMOVAL AND INSTALLATION >

DIAGNOSIS SENSOR UNIT

Exploded View

INFOID:000000007095663

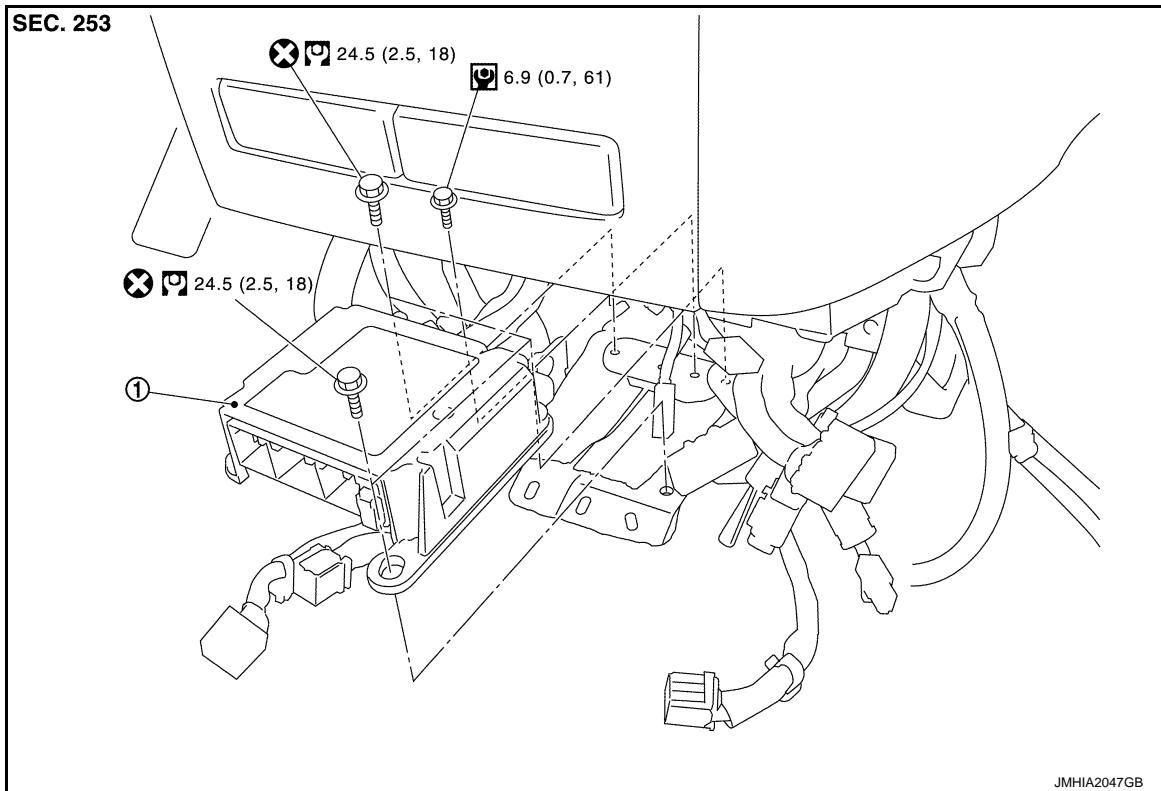

1. Diagnosis sensor unit

⊗ : Always replace after every disassembly.

⊙ : N-m (kg-m, in-lb)

⊕ : N-m (kg-m, ft-lb)

Removal and Installation

INFOID:000000007095664

WARNING:

Always observe the following items for preventing accidental activation.

- Before servicing, turn ignition switch OFF, disconnect battery negative terminal and wait for 3 minutes or more.
- Before disconnecting the air bag sensor unit harness connector, be sure to disconnect each harness connector of the air bag module and pre-tensioner seat belt to prevent air bag deployment by static electricity and pre-tensioner seat belt operation.
- Never use air tools or electric tools for servicing.
- When replacing the air bag diagnosis sensor unit, always check with the parts department for the latest parts information. Installing an incorrect air bag diagnosis sensor unit may or may not cause the air bag warning lamp to illuminate and may cause incorrect deployment of the supplemental air bags and seat belt pre-tensioners in a collision resulting in serious personal injury or death.

REMOVAL

1. Always check the air bag diagnosis sensor unit ECU discriminated number (identification number) using CONSULT.
2. Disconnect each connector of all air bag modules and pre-tensioner seat belts.
3. Remove instrument lower cover (LH and RH) and the instrument lower center cover. Refer to [IP-13, "Removal and Installation"](#).

DIAGNOSIS SENSOR UNIT

< REMOVAL AND INSTALLATION >

4. Remove disc eject switch (model with navigation system). Refer to [AV-567, "Removal and Installation"](#).
5. Remove AV control unit (model with navigation system). Refer to [AV-554, "Removal and Installation"](#).
6. Disconnect the diagnosis sensor unit harness connectors (A).
7. Remove the diagnosis sensor unit mounting bolts (B), and then remove the diagnosis sensor unit.

← : Vehicle front

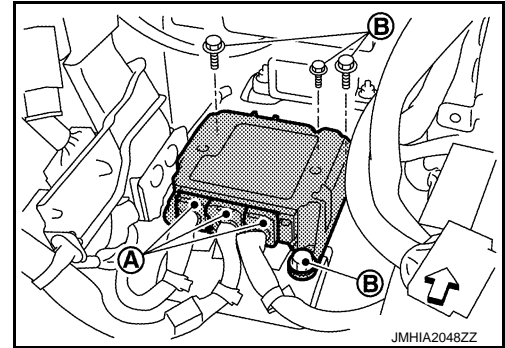

CAUTION:

- To prevent damage to the parts, never impact the diagnosis sensor unit.
- Replace the diagnosis sensor unit if it is dropped or sustains an impact.



- Replace the diagnosis sensor unit of deployed SRS air bag and deployed SRS front seat belt pretensioner.

INSTALLATION

Note the following items, and then install in the reverse order of removal.

CAUTION:

- Never reuse mounting bolts after removal, replace with new bolts.
- Never damage the harness while installing.
- If malfunction is detected by the air bag warning lamp, after repair or replacement of the malfunctioning parts, reset the memory using self-diagnosis or CONSULT. Refer to [SRC-15, "On Board Diagnosis Function"](#) or [SRC-19, "CONSULT Function"](#).
- After the work is completed, check that no system malfunction is detected by air bag warning lamp.
- After replacing the air bag diagnosis sensor unit, confirm using CONSULT that the ECU discriminated number (identification number) of the new replacement air bag sensor unit matches the ECU discriminated number (identification number) of the replaced (old) air bag diagnosis sensor unit.

NOTE:

If the ECU discriminated number of the new replacement air bag diagnosis sensor unit differs from the ECU discriminated number of the replaced air bag diagnosis sensor unit, reconfirm the parts information and verify that the correct air bag diagnosis sensor unit was installed.

SEAT BELT PRE-TENSIONER

< REMOVAL AND INSTALLATION >

SEAT BELT PRE-TENSIONER

Exploded View

INFOID:000000007095665

Refer to [SB-4. "Exploded View"](#).

Removal and Installation

INFOID:000000007095666

For removal and installation procedures, refer to [SB-5. "SEAT BELT RETRACTOR : Removal and Installation"](#).

OCCUPANT DETECTION SYSTEM CONTROL UNIT

< REMOVAL AND INSTALLATION >

OCCUPANT DETECTION SYSTEM CONTROL UNIT

Exploded View

INFOID:000000007095667

The occupant detection system control unit and seat sensor are an integral part of the front passenger seat frame & adjuster assembly.

- Manual seat: Refer to [SE-84, "Exploded View"](#).
- Power seat: Refer to [SE-98, "Exploded View"](#).

Removal and Installation

INFOID:000000007095668

The occupant detection system control unit and seat sensor are an integral part of the front passenger seat frame & adjuster assembly and are replaced as an assembly.

- Manual seat: [SE-87, "Removal and Installation"](#).
- Power seat: [SE-101, "Removal and Installation"](#).

A
B
C
D
E
F
G
I
J
K
L
M
N
O
P

SR