

SECTION **ST**
STEERING SYSTEM

A
 B
 C
 D
 E
 F
ST
 H
 I
 J
 K
 L
 M
 N
 O
 P

CONTENTS

PRECAUTION	2	STEERING COLUMN	12
PRECAUTIONS	2	Exploded View	12
Precaution for Supplemental Restraint System (SRS) "AIR BAG" and "SEAT BELT PRE-TENSIONER"	2	Removal and Installation	12
Service Notice or Precautions for Steering System	2	Inspection	13
PREPARATION	3	STEERING SHAFT	15
PREPARATION	3	Exploded View	15
Special Service Tools	3	Removal and Installation	15
Commercial Service Tools	4	Inspection	17
BASIC INSPECTION	5	STEERING GEAR AND LINKAGE	19
STEERING WHEEL	5	Exploded View	19
Inspection	5	Removal and Installation	21
SYMPTOM DIAGNOSIS	7	Disassembly and Assembly	23
NOISE, VIBRATION AND HARSHNESS (NVH) TROUBLESHOOTING	7	Inspection	29
NVH Troubleshooting Chart	7	POWER STEERING OIL PUMP	31
PERIODIC MAINTENANCE	8	Exploded View	31
POWER STEERING FLUID	8	Removal and Installation	32
Inspection	8	Inspection	33
STEERING WHEEL	10	HYDRAULIC LINE	34
Inspection	10	Exploded View	34
REMOVAL AND INSTALLATION	11	SERVICE DATA AND SPECIFICATIONS (SDS)	35
STEERING WHEEL	11	SERVICE DATA AND SPECIFICATIONS (SDS)	35
Exploded View	11	General Specifications	35
Removal and Installation	11	Steering Wheel	35
		Steering Angle	35
		Steering Column	35
		Intermediate Shaft	35
		Steering Gear and Linkage	35
		Oil Pump	36

PRECAUTIONS

< PRECAUTION >

PRECAUTION

PRECAUTIONS

Precaution for Supplemental Restraint System (SRS) "AIR BAG" and "SEAT BELT PRE-TENSIONER"

INFOID:000000007136304

The Supplemental Restraint System such as "AIR BAG" and "SEAT BELT PRE-TENSIONER", used along with a front seat belt, helps to reduce the risk or severity of injury to the driver and front passenger for certain types of collision. This system includes seat belt switch inputs and dual stage front air bag modules. The SRS system uses the seat belt switches to determine the front air bag deployment, and may only deploy one front air bag, depending on the severity of a collision and whether the front occupants are belted or unbelted. Information necessary to service the system safely is included in the "SRS AIR BAG" and "SEAT BELT" of this Service Manual.

WARNING:

Always observe the following items for preventing accidental activation.

- **To avoid rendering the SRS inoperative, which could increase the risk of personal injury or death in the event of a collision that would result in air bag inflation, all maintenance must be performed by an authorized NISSAN/INFINITI dealer.**
- **Improper maintenance, including incorrect removal and installation of the SRS, can lead to personal injury caused by unintentional activation of the system. For removal of Spiral Cable and Air Bag Module, see "SRS AIR BAG".**
- **Never use electrical test equipment on any circuit related to the SRS unless instructed to in this Service Manual. SRS wiring harnesses can be identified by yellow and/or orange harnesses or harness connectors.**

PRECAUTIONS WHEN USING POWER TOOLS (AIR OR ELECTRIC) AND HAMMERS

WARNING:

Always observe the following items for preventing accidental activation.

- **When working near the Air Bag Diagnosis Sensor Unit or other Air Bag System sensors with the ignition ON or engine running, never use air or electric power tools or strike near the sensor(s) with a hammer. Heavy vibration could activate the sensor(s) and deploy the air bag(s), possibly causing serious injury.**
- **When using air or electric power tools or hammers, always switch the ignition OFF, disconnect the battery, and wait at least 3 minutes before performing any service.**

Service Notice or Precautions for Steering System

INFOID:000000007136307

- In case of removing steering gear assembly, make the final tightening with grounded and unloaded vehicle condition, and then check wheel alignment.
- Observe the following precautions when disassembling.
 - Before disassembly, thoroughly clean the outside of the unit.
 - Disassembly should be done in a clean work area. It is important to prevent the internal parts from becoming contaminated by dirt or other foreign matter.
 - For easier and proper assembly, place disassembled parts in order on a parts rack.
 - Use nylon cloth or paper towels to clean the parts; common shop rags can leave lint that might interfere with their operation.
 - Never reuse non-reusable parts.
 - Before assembling, apply the specified grease to the directed parts.

PREPARATION

< PREPARATION >

PREPARATION

PREPARATION

Special Service Tools

INFOID:000000007050562

The actual shapes of Kent-Moore tools may differ from those of special service tools illustrated here.

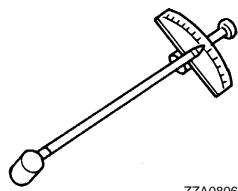
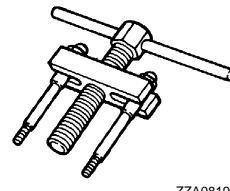
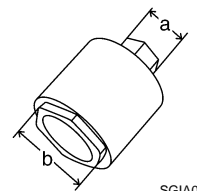
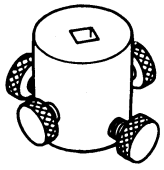
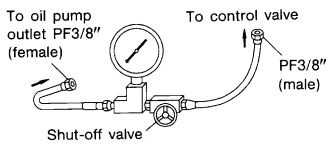
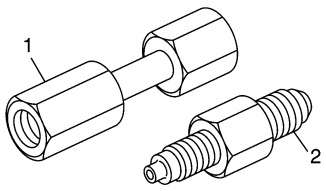
Tool number (Kent-Moore No.) Tool name	Description
ST3127S000 (J-25765-A) Preload gauge  ZZA0806D	<ul style="list-style-type: none"> • Measuring steering wheel turning torque • Measuring steering column rotating torque • Measuring ball joint rotating torque • Measuring pinion rotating torque
ST27180001 (J-25726-A) Steering wheel puller  ZZA0819D	Removing steering wheel
KV48105400 (—) Rear cover wrench a: 19 mm (0.75 in) b: 34.9 mm (1.374 in)  SGIA0516E	Removing and installing rear cover
KV48103400 (—) Preload adapter  ZZA0824D	Measuring pinion rotating torque
KV48103500 (J-26357) Oil pressure gauge  S-NT547	Measuring oil pump relief pressure
KV481059S0 (—) Adapter set 1. KV48105910 Adapter (female side) 2. KV48105920 Adapter (male side)  JPGIA0171ZZ	Measuring oil pump relief pressure

A
B
C
D
E
F
ST
H
I
J
K
L
M
N
O
P

PREPARATION

< PREPARATION >

Commercial Service Tools

INFOID:000000007050563

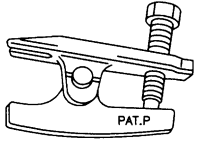
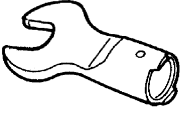
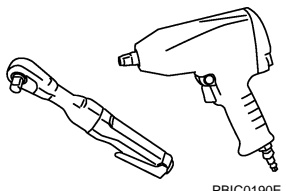
Tool name	Description
Ball joint remover  S-NT146	Removing steering outer socket
Open head  ZZA0822D	Tightening end cover assembly
Power tool  PBIC0190E	Loosening bolts and nuts

STEERING WHEEL

< BASIC INSPECTION >

BASIC INSPECTION

STEERING WHEEL

Inspection

INFOID:000000007050574

NEUTRAL POSITION STEERING WHEEL

1. Check that steering gear assembly, steering column assembly and steering wheel are installed in the correct position.
2. Check wheel alignment within specification. Refer to [FSU-6, "Inspection"](#).
3. Set the vehicle to the straight-ahead position and confirm steering wheel is in the neutral position.
 - Loosen outer socket lock nut and turn inner socket to left and right equally to make fine adjustments if steering wheel is not in the neutral position.

CAUTION:

If the adjustment is performed by using the inner socket, check wheel alignment after the adjustment. Refer to [FSU-6, "Inspection"](#).

STEERING WHEEL TURNING TORQUE

1. Park the vehicle on a level and dry surface, set parking brake.
2. Tires need to be inflated to the specified pressure. Refer to [WT-51, "Tire Air Pressure"](#).
3. Remove driver air bag module. Refer to [SR-11, "Removal and Installation"](#).
4. Start the engine.
5. Check that the reading is within the following specified range using the preload gauge (A) [SST: ST3127S000 (J-25765-A)].

Steering wheel turning torque : Refer to [ST-35, "Steering Wheel"](#).

NOTE:

To check, oil temperature must be room temperature [recommended oil temperature: approximately 20°C (68°F)].

6. If steering wheel turning torque is out of the specification, check rack sliding force and relief hydraulic pressure of oil pump. Regarding relief hydraulic pressure of oil pump, refer to [ST-33, "Inspection"](#).

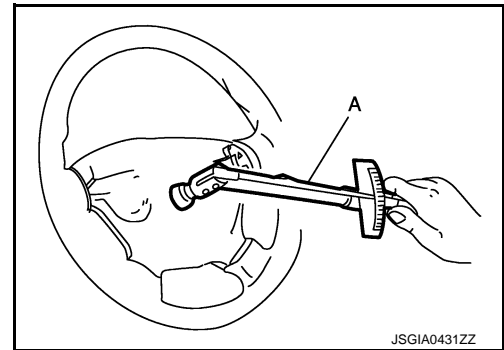

RACK SLIDING FORCE

1. Disconnect lower joint from steering gear assembly. Refer to [ST-15, "Removal and Installation"](#).
2. Disconnect steering outer socket from steering knuckle. Refer to [ST-21, "Removal and Installation"](#).
3. Run the engine at idle and adjust the reservoir tank oil temperature to room temperature [recommended oil temperature: approximately 20°C (68°F)].
4. While pulling outer socket slowly in ± 11.5 mm (± 0.453 in) range from neutral position, make sure rack sliding force is within specification.

Rack sliding force : Refer to [ST-35, "Steering Gear and Linkage"](#).

- If rack sliding force is not within specification, overhaul steering gear assembly.

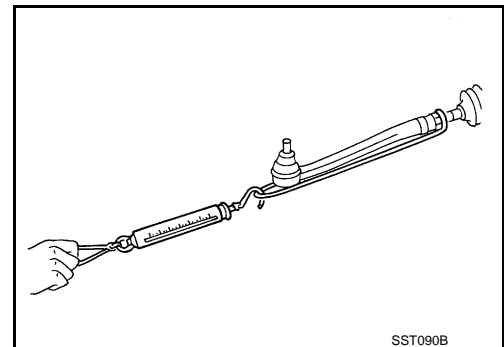

FRONT WHEEL TURNING ANGLE

1. Perform toe-in inspection. Refer to [FSU-6, "Inspection"](#).

CAUTION:

Perform front wheel turning angle inspection, after toe-in inspection.

STEERING WHEEL

< BASIC INSPECTION >

- Place front wheels on turning radius gauges and rear wheels on stands, so that vehicle can be level.
- Check the maximum inner and outer wheel turning angles for LH and RH road wheels.

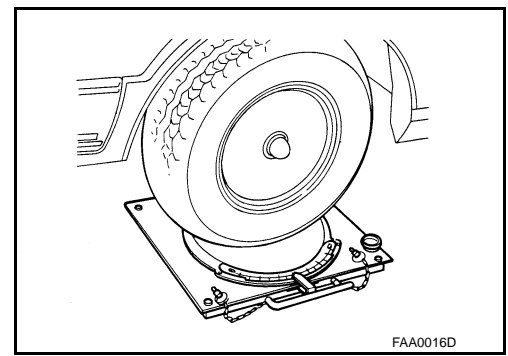

- With the engine at idle, turn steering wheel from full left stop to full right stop and measure the turning angles (maximum inner wheel steering angle and maximum outer wheel steering angle).

- A : Inner wheel angle
B : Outer wheel angle

Steering angle : Refer to [ST-35, "Steering Angle"](#).

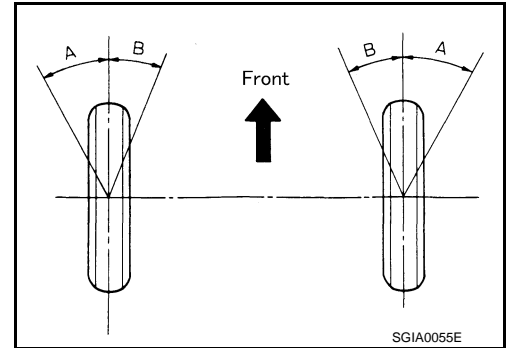

- Check the following items when turning angle is out of the standard.
 - Check the neutral position of the rack stroke (L).

Rack stroke neutral position (L) : Refer to [ST-35, "Steering Gear and Linkage"](#).

- Disassemble steering gear assembly to check the cause that rack stroke is outside of the standard.
- Steering angles are not adjustable. Check steering gear assembly, steering column assembly and front suspension components for wear or damage if any of the turning angles are different from the specified value. Replace any of them, if any non-standard condition exists.

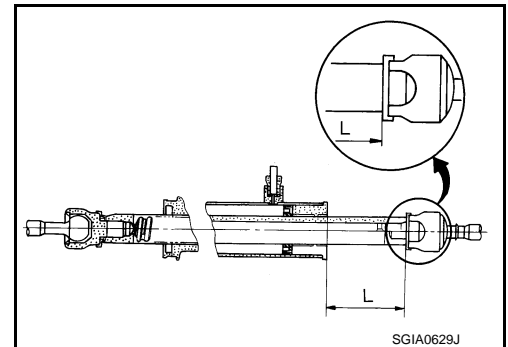

NOISE, VIBRATION AND HARSHNESS (NVH) TROUBLESHOOTING

< SYMPTOM DIAGNOSIS >

SYMPTOM DIAGNOSIS

NOISE, VIBRATION AND HARSHNESS (NVH) TROUBLESHOOTING

NVH Troubleshooting Chart

INFOID:000000007050588

Use the chart below to find the cause of the symptom. If necessary, repair or replace these parts.

Symptom		Possible cause and SUSPECTED PARTS															Reference					
		Fluid level	Air in hydraulic system	Outer/inner socket ball joint swinging torque	Outer/inner socket ball joint rotating torque	Outer/inner socket ball joint end play	Steering fluid leakage	Steering wheel play	Steering gear rack sliding force	Improper steering wheel	Improper installation or looseness of tilt lock lever	Mounting looseness	Steering column deformation or damage	Improper installation or looseness of steering column	Steering linkage looseness	AXLE and SUSPENSION		TIRE	ROAD WHEEL	DRIVE SHAFT	BRAKE	
Steering	Noise	x	x	x	x	x	x	x	x				x	x	x	x	x	x	x	x	x	ST-8, "Inspection" ST-8, "Inspection" ST-29, "Inspection" ST-29, "Inspection" ST-29, "Inspection" ST-8, "Inspection" ST-5, "Inspection" ST-5, "Inspection" — — ST-19, "Exploded View" ST-13, "Inspection" ST-12, "Exploded View" ST-19, "Exploded View" NVH in FAX, RAX, FSU, RSU section. NVH in WT section. NVH in WT section. NVH in FAX section. NVH in BR section.
	Shake									x	x	x				x	x	x	x	x		
	Vibration									x	x	x	x	x		x	x		x			
	Shimmy									x		x			x	x	x	x			x	
	Judder										x	x			x	x	x	x			x	

x: Applicable

A
B
C
D
E
F
ST
H
I
J
K
L
M
N
O
P

POWER STEERING FLUID

< PERIODIC MAINTENANCE >

PERIODIC MAINTENANCE

POWER STEERING FLUID

Inspection

INFOID:000000007050589

FLUID LEVEL

With the engine stopped, check that the fluid level is between MIN and MAX of the reservoir cap level gauge when the fluid temperature is in COLD state.

COLD : Fluid temperature 0 – 30°C (32 – 86°F)

Recommended fluid : Refer to [MA-10, "Fluids and Lubricants"](#).

Fluid capacity : Refer to [ST-35, "General Specifications"](#).

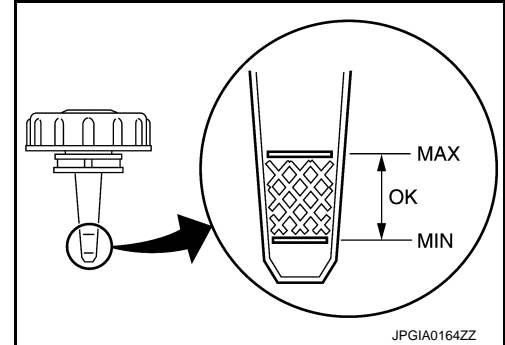

CAUTION:

- The fluid level should not exceed the MAX line. Excessive fluid causes fluid leakage from the cap.
- Never reuse drained power steering fluid.
- Always use the specified fluid. Refer to [MA-10, "Fluids and Lubricants"](#).

FLUID LEAKAGE

Check hydraulic connections for fluid leakage, cracks, damage, looseness, or wear.

1. Run the engine at idle and adjust the reservoir tank oil temperature to room temperature [recommended oil temperature: approximately 20°C (68°F)].
2. Turn steering wheel several times from full left stop to full right stop.
3. Hold steering wheel at each lock position for five seconds and carefully check for fluid leakage.

CAUTION:

Never hold the steering wheel in a locked position for more than 10 seconds. (There is the possibility that power steering oil pump assembly may be damaged.)

4. If fluid leaks from the joint, loosen the joint part and retighten it, being careful not to damage it.

CAUTION:

For tightening torque and non reusable parts, refer to [ST-34, "Exploded View"](#).

5. If fluid leakage from oil pump is noticed, check oil pump. Refer to [ST-33, "Inspection"](#).
6. Check steering gear boots for accumulation of fluid leaked from steering gear.

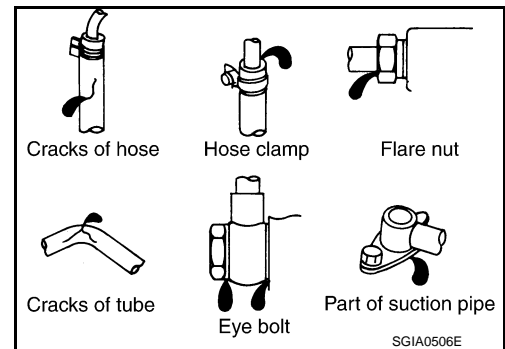

BLEEDING HYDRAULIC SYSTEM

If air bleeding is not complete, the following symptoms can be observed.

- Bubbles are created in reservoir tank.
- Clicking noise can be heard from oil pump.
- Excessive buzzing in the oil pump.

NOTE:

Fluid noise may occur in the steering gear or oil pump. This does not affect performance or durability of the system.

1. Turn steering wheel several times from full left stop to full right stop with engine stopped.

CAUTION:

Fill reservoir tank with a sufficient amount of fluid so that fluid level is not below the MIN line while turning steering wheel.

2. Start the engine and hold steering wheel at each lock position for 3 seconds at idle to check for fluid leakage.
3. Repeat step 2 above several times at approximately 3 seconds intervals.

POWER STEERING FLUID

< PERIODIC MAINTENANCE >

CAUTION:

Never hold the steering wheel in a locked position for more than 10 seconds. (There is the possibility that oil pump may be damaged.)

4. Check fluid for bubbles and white contamination.
 - Stop the engine if bubbles and white contamination do not drain out. Perform step 2 and 3 above after waiting until bubbles and white contamination drain out.
5. Stop the engine, and then check fluid level.

A

B

C

D

E

F

ST

H

I

J

K

L

M

N

O

P

STEERING WHEEL

< PERIODIC MAINTENANCE >

STEERING WHEEL

Inspection

INFOID:000000007050590

STEERING WHEEL AXIAL END PLAY

1. Check installation conditions of steering gear assembly, front suspension assembly, axle and steering column assembly.
2. Check if movement exists when steering wheel is moved up and down, to the left and right and to the axial direction.

Steering wheel axial end play : Refer to [ST-35, "Steering Wheel"](#).

3. Check the following items when steering wheel axial end play is out of the standard.
 - Check the steering column assembly mounting condition. Refer to [ST-12, "Exploded View"](#).
 - Check steering gear assembly mounting condition for looseness. Refer to [ST-19, "Exploded View"](#).

STEERING WHEEL PLAY

1. Turn steering wheel so that front wheels come to the straight-ahead position.
2. Start the engine and lightly turn steering wheel to the left and right until front wheels start to move.
3. Measure steering wheel movement on the outer circumference.

Steering wheel play : Refer to [ST-35, "Steering Wheel"](#).

4. Check the following items when steering wheel play is out of the standard.
 - Check backlash for each joint of steering column assembly.
 - Check installation condition of steering gear assembly.

STEERING WHEEL

< REMOVAL AND INSTALLATION >

REMOVAL AND INSTALLATION

STEERING WHEEL

Exploded View

INFOID:000000007050591

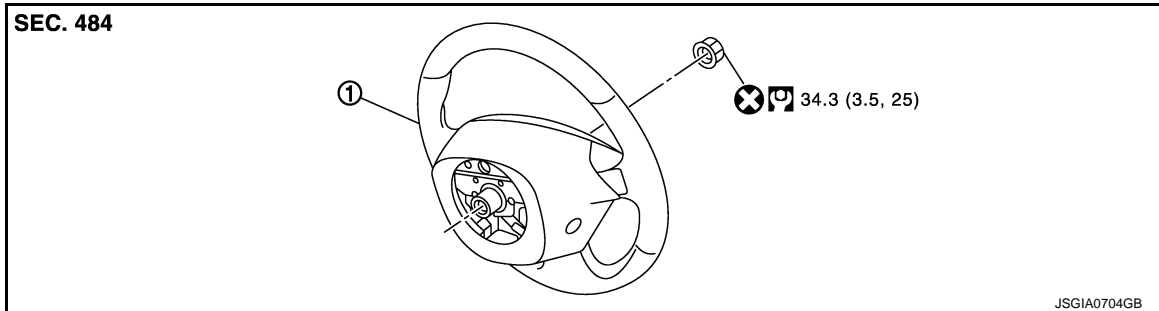

1. Steering wheel

: N·m (kg·m, ft·lb)

: Always replace after every disassembly.

Removal and Installation

INFOID:000000007050592

REMOVAL

NOTE:

When reconnecting spiral cable, fix cable with a tape so that fixing case and rotating part keep aligned. This will omit neutral position alignment procedure during spiral cable installation.

1. Set vehicle to the straight-ahead position.
2. Remove driver air bag module. Refer to [SR-11, "Removal and Installation"](#).
3. Remove steering wheel lock nut after steering is locked.
4. Remove steering wheel with the steering wheel puller (A) [SST: ST27180001 (J-25726-A)].

NOTE:

When removing, place a matching mark on both steering wheel and shaft of steering column assembly before removing.

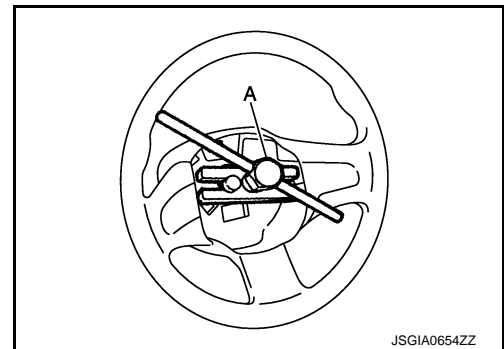

INSTALLATION

Note the following, and install in the reverse order of removal.

- Check the spiral cable neutral position after replacing or rotating spiral cable. Refer to [SR-14, "Removal and Installation"](#).

CAUTION:

- Never twist spiral cable excessively after it becomes tight. (Twisting may cause the cable to be torn off.)
- Never reuse steering wheel lock nut.

STEERING COLUMN

< REMOVAL AND INSTALLATION >

STEERING COLUMN

Exploded View

INFOID:000000007050594

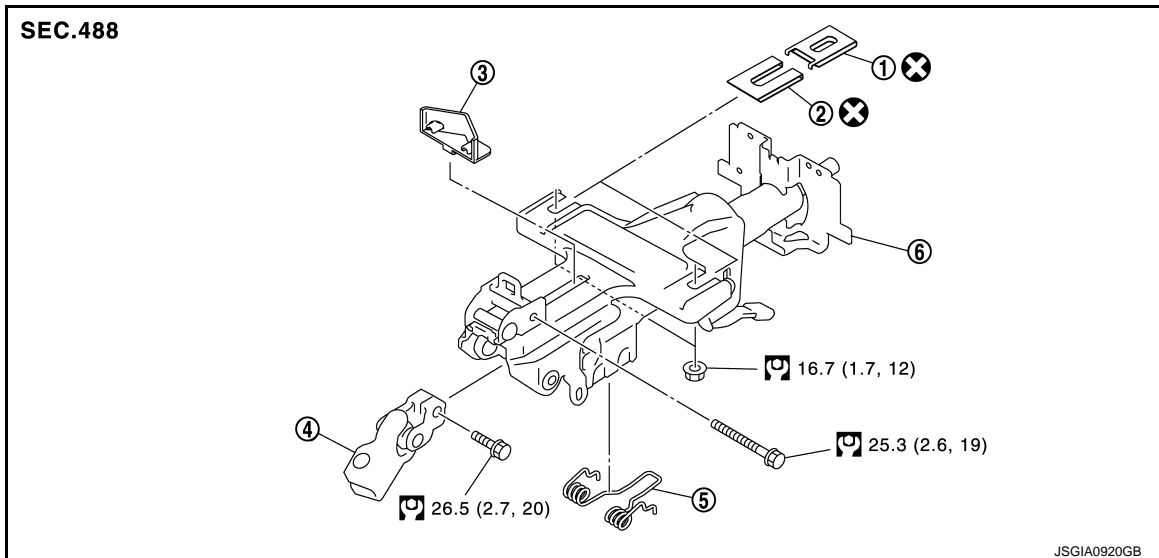

- | | | |
|------------------------|------------------------|-----------------------------|
| 1. Slide plate (outer) | 2. Slide plate (inner) | 3. Cover |
| 4. Upper joint | 5. Spring | 6. Steering column assembly |

: N·m (kg·m, ft·lb)

: Always replace after every disassembly.

Removal and Installation

INFOID:000000007050595

REMOVAL

CAUTION:

- Never impact on the axis when removing steering column assembly.
- Be careful when removing steering column assembly from the vehicle because it is heavy.
- While removing the steering column assembly, never move the steering gear.
- When removing the steering column assembly, be careful not to allow the intermediate shaft to turn.
- To prevent a malfunction and deformation from occurring in the tilt mechanism, never apply excessive force to the tilt lever.

1. Set the vehicle to the straight-ahead position.
2. Place the tilt to the highest level.

CAUTION:

Securely lock the tilt lever.

3. Remove driver air bag module. Refer to [SR-11, "Removal and Installation"](#).
4. Remove steering wheel. Refer to [ST-11, "Removal and Installation"](#).
5. Remove instrument lower panel LH. Refer to [IP-13, "Removal and Installation"](#).
6. Remove the steering column cover. Refer to [IP-13, "Removal and Installation"](#).
7. Remove spiral cable. Refer to [SR-14, "Removal and Installation"](#).
8. Remove combination switch. Refer to [BCS-83, "Removal and Installation"](#).
9. Remove knee protector.
10. Disconnect each switch harness connectors installed to steering column assembly.
11. Remove upper joint mounting bolt, and separate upper joint from steering column.

CAUTION:

- When removing, place a matching mark on both upper joint and steering column assembly before removing.

STEERING COLUMN

< REMOVAL AND INSTALLATION >

- When removing upper joint, never insert a tool, such as a screwdriver, into the yoke groove to pull out the upper joint. In case of the violation of the above, replace upper joint with a new one.

12. Remove steering column assembly.

NOTE:

The intermediate shaft slides in axial direction.

13. Remove slide plate (outer, inner), cover, and spring from steering column.

14. Perform inspection after removal. Refer to [ST-13, "Inspection"](#).

INSTALLATION

Note the following, and install in the reverse order of removal.

CAUTION:

- Never impact on the axis when removing steering column assembly.
- While removing the steering column assembly, never move the steering gear.
- When connecting upper joint and steering column assembly, make sure the bolt is securely seated in groove of column shaft before final tightening.
- When installing the steering column assembly, temporarily tighten the bolt and nuts before tightening to the specified torque in the order shown in the figure.

CAUTION:

- Never reuse slide plate (outer, inner) (1).
- The slide plate must be securely pressed in before tightening the nut of slide plate (outer, inner).
- Perform inspection after installation. Refer to [ST-13, "Inspection"](#).

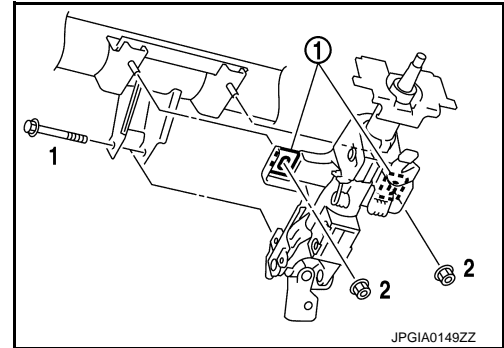

INFOID:000000007050596

Inspection

INSPECTION AFTER REMOVAL

- Check each part of steering column assembly for damage or other malfunctions. Replace if necessary.
- Measure steering column rotating torque using a preload gauge (A) [SST: ST3127S000 (J-25765-A)]. Replace steering column assembly if the rotating torque is outside the standard.

Rotating torque : Refer to [ST-35, "Steering Column"](#).

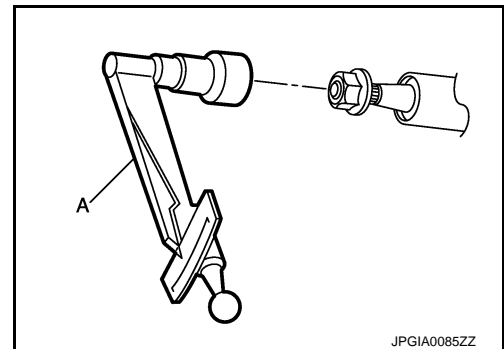

- Check the following item, if vehicle has been involved in a minor collision. Replace steering column assembly if outside the standard.
- Check the length "L" shown in the figure.

CAUTION:

Set the telescopic mechanism to its maximum length to measure the length of steering column.

Steering column length (L) : Refer to [ST-35, "Steering Column"](#).

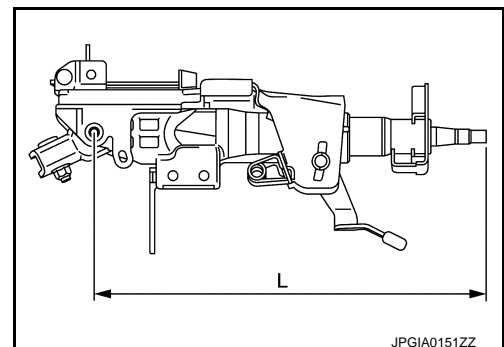

STEERING COLUMN

< REMOVAL AND INSTALLATION >

- Check the dimension "A" shown in the figure.

Impact displacement absorption part dimension (A) : Refer to [ST-35. "Steering Column"](#).

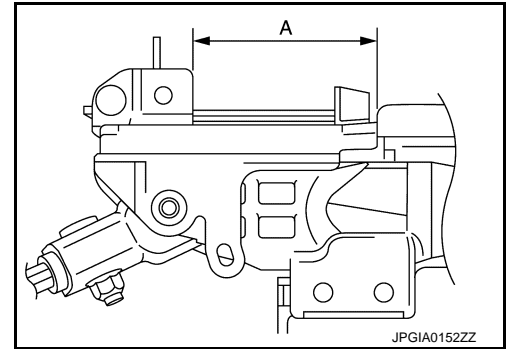

INSPECTION AFTER INSTALLATION

- Check each part of steering column assembly for damage or other malfunctions. Replace if necessary.
- Check that there is no malfunction, such as unusual steering feel or interference when operating tilt and telescopic.
- Check tilt and telescopic mechanism operating range "L", "T" as shown in the figure.

Tilt operating range (T) : Refer to [ST-35. "Steering Column"](#).

Telescopic operating range (L) : Refer to [ST-35. "Steering Column"](#).

- Check the steering wheel play, neutral position steering wheel, steering wheel turning torque, and front wheel turning angle.
- Steering wheel play: Refer to [ST-10. "Inspection"](#).
- neutral position steering wheel, steering wheel turning torque, and front wheel turning angle: Refer to [ST-5. "Inspection"](#).
- Adjust neutral position of steering angle sensor. Refer to [BRC-48. "Work Procedure"](#).

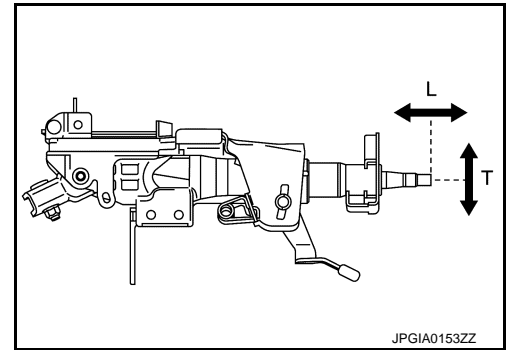

STEERING SHAFT

< REMOVAL AND INSTALLATION >

- Place a matching mark on both upper joint and steering column assembly before removing upper joint.
 - When removing upper joint, never insert a tool, such as a screwdriver, into the yoke groove to pull out the upper joint. In case of the violation of the above, replace upper joint with a new one.
6. Separate hole cover seal with the following procedure.
 - a. Turn tub (A) of hole cover (1).

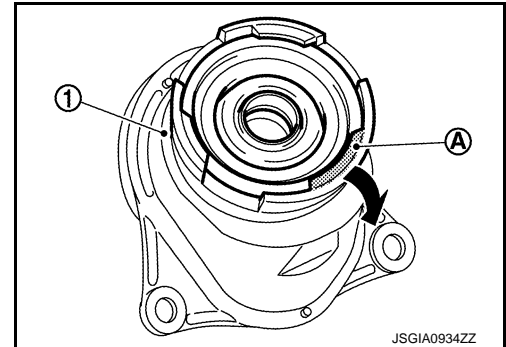

- b. Separate hole cover seal (1) from hole cover, using a suitable lever with leverage.

Lever insert range (A) : 15 mm (0.59 in)

CAUTION:

If the lever is inserted into an area other than the lever insertion range, the protrusion on the hole cover may be damaged.

7. Remove hole cover mounting nuts.
8. Remove the intermediate shaft and hole cover.
9. Perform inspection after removal. Refer to [ST-17, "Inspection"](#).

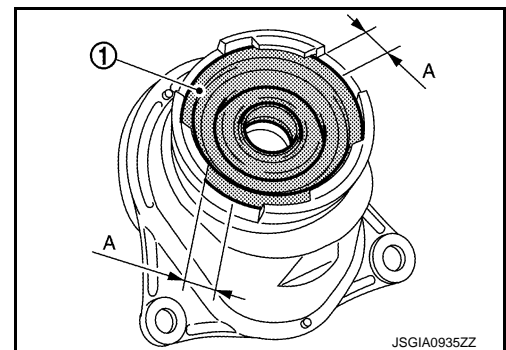

INSTALLATION

Note the following, and install in the reverse order of removal.

CAUTION:

Spiral cable may be cut if steering wheel turns while separating steering column assembly and steering gear assembly. Be sure to secure steering wheel using string to avoid turning.

- Never damage seal lip when inserting hole cover seal to intermediate shaft.
- When installing hole cover seal (1) to hole cover (2), Insert hole cover seal flange (A) with the groove (B) of hole cover.
- For intermediate shaft and upper joint mounting bolt direction, refer to [ST-15, "Exploded View"](#). (Do not insert it from the other side.)

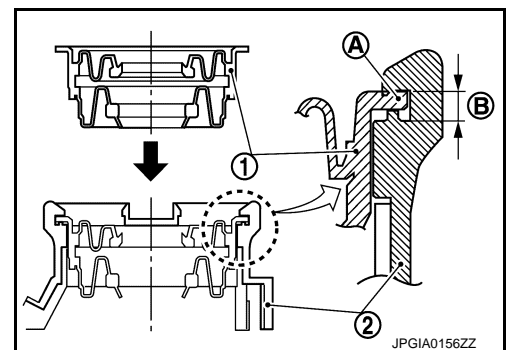

- When installing intermediate shaft to steering gear assembly, follow the procedure listed below.

STEERING SHAFT

< REMOVAL AND INSTALLATION >

- Align slit of intermediate shaft (1) with rear cover cap projection (A), insert intermediate shaft end face (B) until contacts steering gear assembly end face (C).
- When tightening the mounting bolt of the intermediate shaft (steering gear assembly side), manually tighten the bolt and check that there is no hook and scratch. Check that the bolt is properly placed in the groove of the steering gear assembly before tightening the bolt to the specified torque.

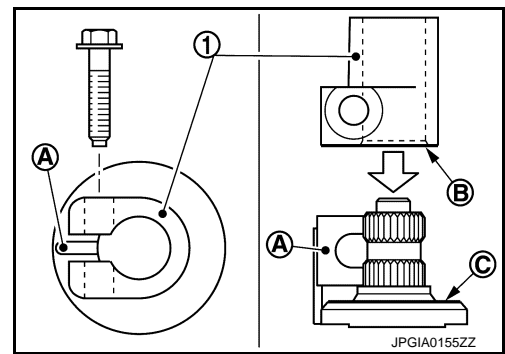

- When installing intermediate shaft to upper joint, follow the procedure listed below.
- To tighten upper joint mounting bolt (intermediate shaft side), manually tighten the bolt to check for scoring or galling before tightening the bolt to the specified torque.
- After installation, check that there is no clearance (A) between intermediate shaft (1) and upper joint yoke and between intermediate shaft and mounting bolt (3).
- Perform inspection after installation. Refer to [ST-17, "Inspection"](#).

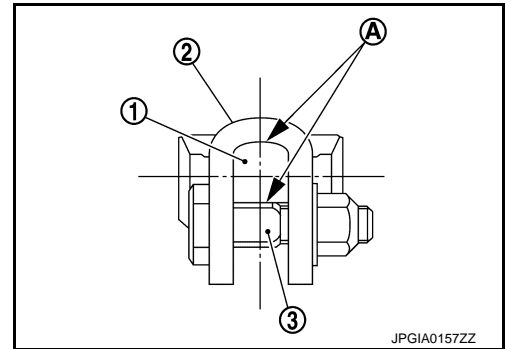

Inspection

INSPECTION AFTER REMOVAL

Check the following items and replace, if necessary.

- Check hole cover and hole cover seal for damage or other malfunctions.
- Check intermediate shaft and upper joint for damage or other malfunctions.
- Check the length (L) of the intermediate shaft.

CAUTION:

Check the length extended position of the intermediate shaft.

Shaft length (L) : Refer to [ST-35, "Intermediate Shaft"](#).

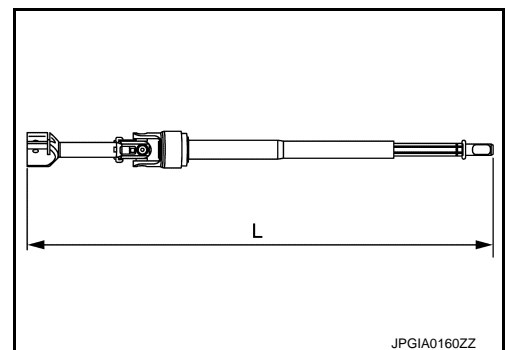

- Check the sliding range (A) of the intermediate shaft.

CAUTION:

Check the sliding range (between the extended position and the contracted position) of the intermediate shaft.

Shaft sliding range (A) : Refer to [ST-35, "Intermediate Shaft"](#).

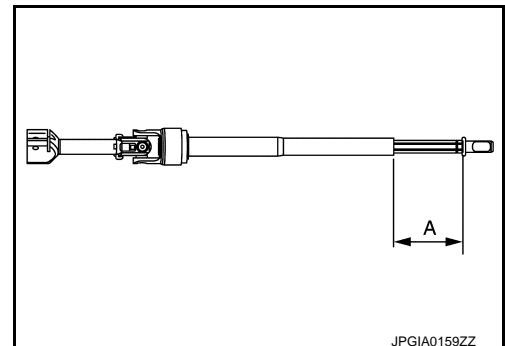

INSPECTION AFTER INSTALLATION

Check the following items and replace, if necessary.

STEERING SHAFT

< REMOVAL AND INSTALLATION >

- Check hole cover and hole cover seal for damage or other malfunctions.
- Check intermediate shaft and upper joint for damage or other malfunctions.
- Check if steering wheel turns smoothly when it is turned several times fully to the end of the left and right.
- Check the steering wheel play, neutral position steering wheel, steering wheel turning torque, and front wheel turning angle.
- Steering wheel play: Refer to [ST-10, "Inspection"](#).
- neutral position steering wheel, steering wheel turning torque, and front wheel turning angle: Refer to [ST-5, "Inspection"](#).
- Adjust neutral position of steering angle sensor. Refer to [BRC-48, "Work Procedure"](#).

STEERING GEAR AND LINKAGE

< REMOVAL AND INSTALLATION >

STEERING GEAR AND LINKAGE

Exploded View

INFOID:000000007050604

REMOVAL

For 3.5LE Grade

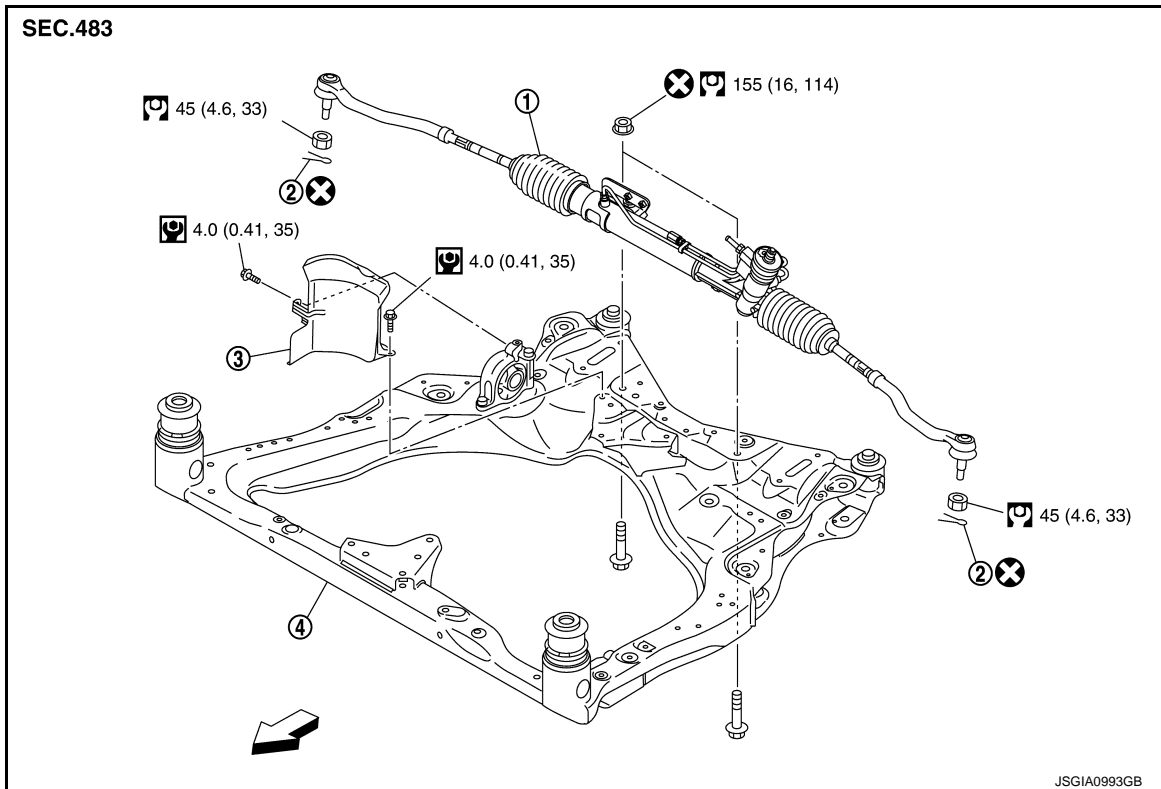

- 1. Steering gear assembly
- 2. Cotter pin
- 3. Heat insulator
- 4. Front suspension member

⇐: Vehicle front

: N·m (kg-m, in-lb)

: N·m (kg-m, ft-lb)

: Always replace after every disassembly.

Except for 3.5LE Grade

A
B
C
D
E
F
ST
H
I
J
K
L
M
N
O
P

STEERING GEAR AND LINKAGE

< REMOVAL AND INSTALLATION >

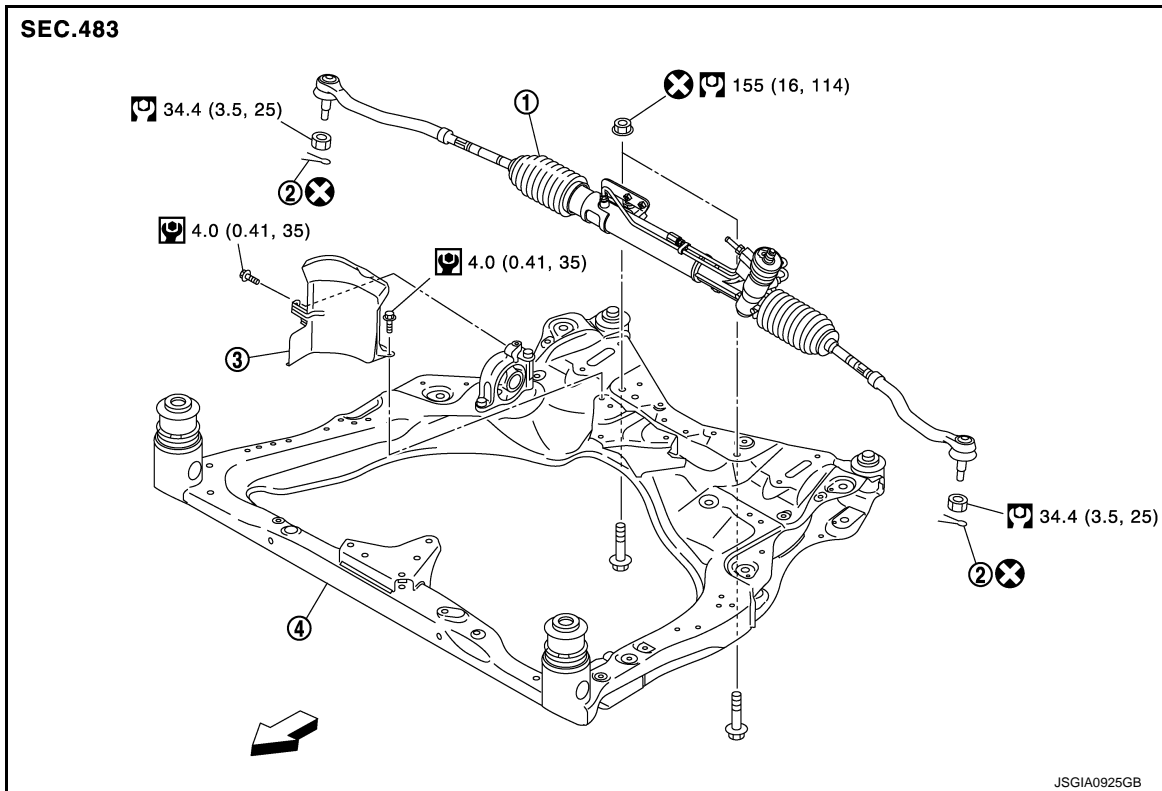

1. Steering gear assembly

2. Cotter pin

3. Heat insulator

4. Front suspension member

←: Vehicle front

: N-m (kg-m, in-lb)

: N-m (kg-m, ft-lb)

: Always replace after every disassembly.

DISASSEMBLY

STEERING GEAR AND LINKAGE

< REMOVAL AND INSTALLATION >

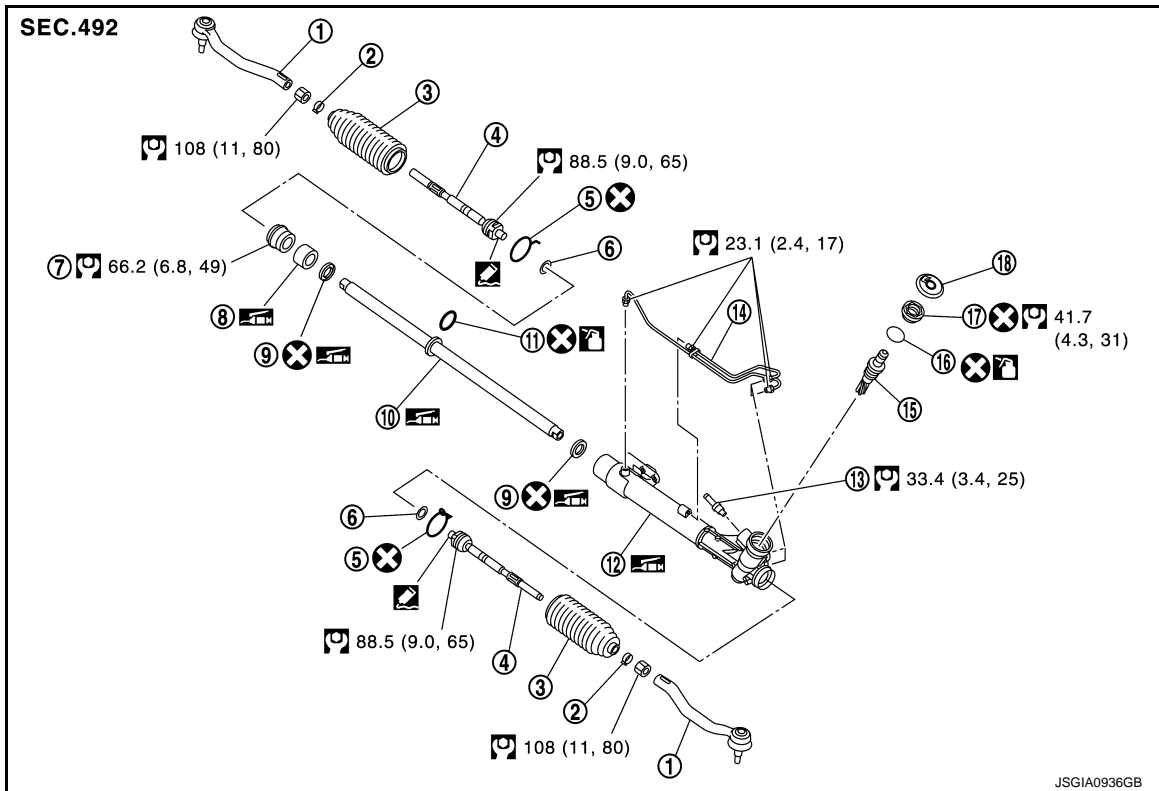

- | | | |
|-------------------------|--------------------------------|---------------------------|
| 1. Outer socket | 2. Boot clamp | 3. Boot |
| 4. Inner socket | 5. Boot clamp (stainless wire) | 6. Spacer |
| 7. End cover assembly | 8. Rack spacer | 9. Rack oil seal |
| 10. Rack assembly | 11. O-ring | 12. Gear housing assembly |
| 13. Low pressure piping | 14. Cylinder tubes | 15. Gear-sub assembly |
| 16. O-ring | 17. Rear cover | 18. Rear cover cap |

: N·m (kg-m, ft-lb)

: Always replace after every disassembly.

: Apply power steering fluid. Refer to [MA-10, "Fluids and Lubricants"](#).

: Apply Genuine High Strength Thread Locking Sealant or equivalent. Refer to [GI-22, "Recommended Chemical Products and Sealants"](#).

: Apply multi-purpose grease.

Removal and Installation

INFOID:000000007050605

REMOVAL

1. Set the vehicle to the straight-ahead position.
2. Remove tires with power tool. Refer to [WT-46, "Exploded View"](#).
3. Remove engine under cover. Refer to [EXT-27, "Exploded View"](#).
4. Remove exhaust front tube. Refer to [EX-6, "Removal and Installation"](#).
5. Remove heat insulator from front suspension member.
6. Remove cotter pin, and then loosen the nut.

STEERING GEAR AND LINKAGE

< REMOVAL AND INSTALLATION >

7. Remove steering outer socket from steering knuckle so as not to damage ball joint boot using a ball joint remover (A) (commercial service tool).

CAUTION:

Temporarily tighten the nut to prevent damage to threads and to prevent the ball joint remover from suddenly coming off.

8. Remove high pressure piping and return hose of hydraulic piping, and then drain power steering fluid.
9. Remove intermediate shaft mounting bolt (steering gear side), and separate intermediate shaft from steering gear assembly.

CAUTION:

- Place a matching mark on both intermediate shaft and steering gear assembly before removing intermediate shaft.
- When removing intermediate shaft, never insert a tool, such as a screwdriver, into the yoke groove to pull out the intermediate shaft. In case of the violation of the above, replace intermediate shaft with a new one.
- Spiral cable may be cut if steering wheel turns while separating intermediate shaft and steering gear assembly. Be sure to secure steering wheel using string to avoid turning.

10. Remove stabilizer connecting rod. Refer to [FSU-14, "Removal and Installation"](#).

11. Set suitable jack under front suspension member.

CAUTION:

- At this step, the jack must be set only for supporting the removal procedure. For details on jacking up the vehicle, refer to [GI-29, "Garage Jack and Safety Stand and 2-Pole Lift"](#).
- Never damage the front suspension member with a jack.
- Check the stable condition when using a jack.

12. Remove engine mounting insulator (rear) mounting bolts. Refer to [EM-56, "Removal and Installation"](#).

13. Remove engine mounting insulator (RH). Refer to [EM-56, "Removal and Installation"](#).

14. Remove steering gear assembly mounting bolts, and nuts.

15. Remove suspension member stay, and remove suspension member mounting bolts, and nuts. Refer to [FSU-16, "Removal and Installation"](#).

16. Lower the suitable jack for the front suspension member to the steering gear assembly can be removed.

CAUTION:

Operate while checking that jack supporting status is stable.

17. Remove steering gear assembly.

INSTALLATION

Note the following, and install in the reverse order of removal.

CAUTION:

Spiral cable may be cut if steering wheel turns while separating intermediate shaft and steering gear assembly. Be sure to secure steering wheel using string to avoid turning.

- When installing return hoses (1), refer to the figure.

CAUTION:

- Never apply fluid to the hose and tube (2).
- Insert hose securely until it contacts spool (A) of tube.
- Leave clearance (L) when installing clamp (3).

L : 3 – 8 mm (0.12 – 0.31 in)

- When installing intermediate shaft to steering gear assembly, follow the procedure listed below.

- Set rack of steering gear in the neutral position.

NOTE:

To get the neutral position of rack, turn gear-sub assembly and measure the distance of inner socket, and then measure the intermediate position of the distance.

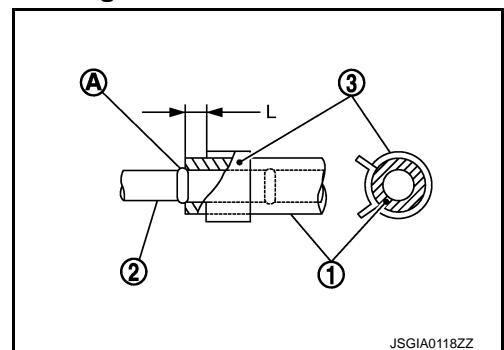
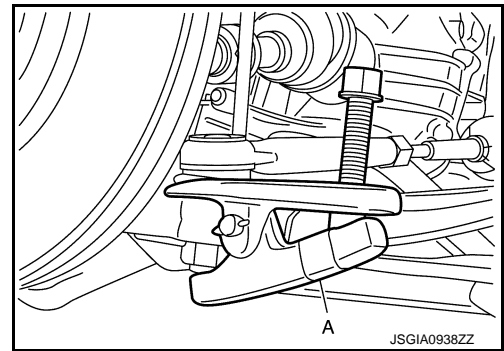

STEERING GEAR AND LINKAGE

< REMOVAL AND INSTALLATION >

- Align slit of intermediate shaft (1) with rear cover cap projection (A), insert intermediate shaft end face (B) until contacts steering gear assembly end face (C).
- When tightening the mounting bolt of the intermediate shaft (steering gear assembly side), manually tighten the bolt and check that there is no hook and scratch. Check that the bolt is properly placed in the groove of the steering gear assembly before tightening the bolt to the specified torque.
- Perform inspection after installation. Refer to [ST-29, "Inspection"](#).

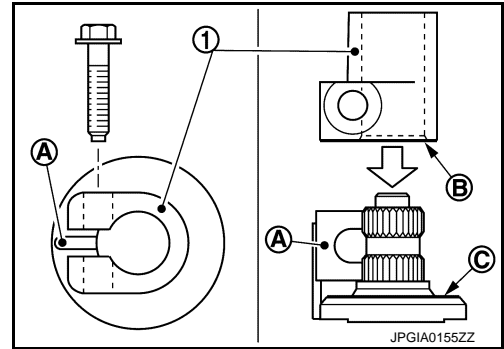

INFOID:000000007050606

Disassembly and Assembly

DISASSEMBLY

CAUTION:

- Disassemble and assemble steering gear assembly by fixing the mounting area with a vise using copper plates.
- Clean steering gear assembly with kerosene before disassembling. Be careful to avoid splashing or applying any kerosene over connector of discharge port or return port.

1. Remove low pressure piping.
2. Remove cylinder tubes from gear housing assembly.
3. Remove rear cover cap from gear-sub assembly.
4. Remove rear cover from gear-sub assembly, using the rear cover wrench (A) [SST: KV48105400 (—)]

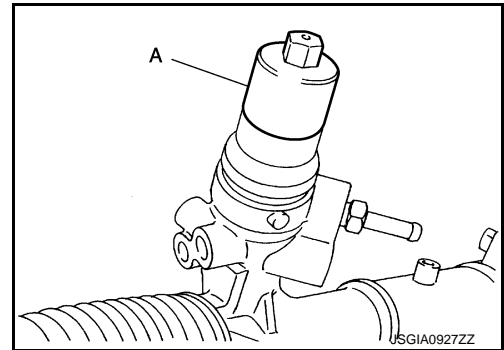

5. Remove O-ring from rear cover.

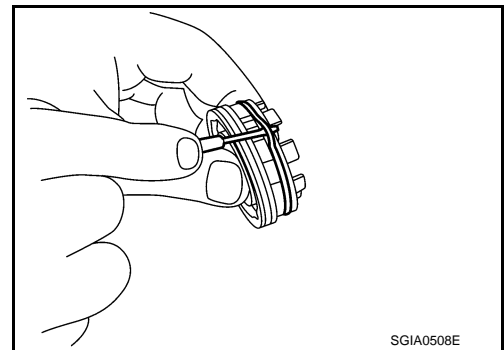

6. Measure adjusting screw height "H", and loosen adjusting screw.

CAUTION:

- Never loosen adjusting screw 2 turns or more.
- Replace steering gear assembly if adjusting screw is loosened 2 turns or more and it is removed.

7. Remove gear-sub assembly from gear housing assembly.
8. Loosen outer socket lock nut, and remove outer socket.
9. Remove boot clamps, and then remove boot from inner socket.

CAUTION:

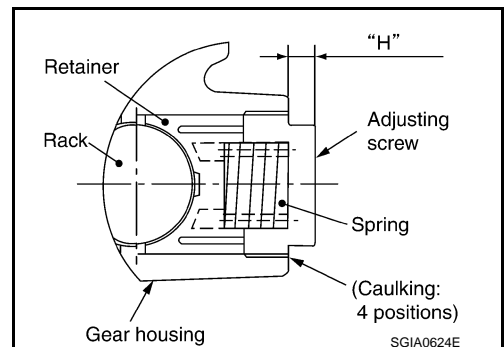

STEERING GEAR AND LINKAGE

< REMOVAL AND INSTALLATION >

Never damage inner socket and gear housing assembly when removing boot. Inner socket and gear housing assembly must be replaced if inner socket and gear housing assembly are damaged because it may cause foreign material interfusion.

10. Remove inner socket from rack assembly.

11. Remove spacer from rack assembly.

CAUTION:

Never damage rack assembly.

12. Drill out the clinching part of gear housing assembly (end cover assembly side) outer rim with a 3 mm (0.12 in) drill bit. [Drill for approximately 1.5 mm (0.059 in) depth.]

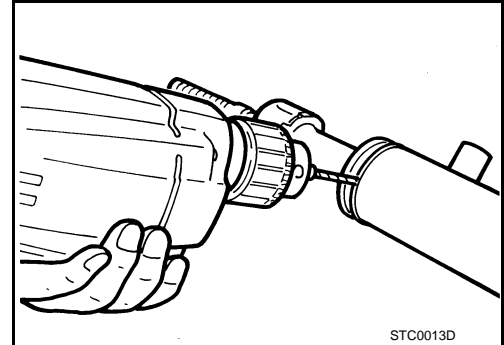

13. Remove end cover assembly with a 36 mm (1.42 in) open head (commercial service tool).

CAUTION:

Never damage rack assembly surface when removing. Rack assembly must be replaced if damaged because it may cause fluid leakage.

14. Pull rack assembly together with rack spacer and rack oil seal (outer side) from gear housing assembly.

CAUTION:

Never damage cylinder inner wall when remove rack assembly. Gear housing assembly must be replaced if damaged because it may cause fluid leakage.

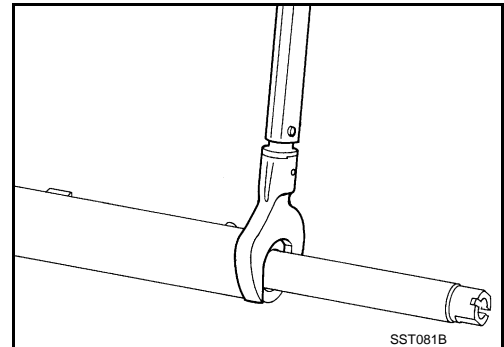

15. Remove O-ring from rack assembly.

CAUTION:

Never damage rack assembly. Rack assembly must be replaced if damaged because it may cause fluid leakage.

16. Push rack oil seal inside with a 29 mm (1.14 in) socket and an extension bar to push out rack oil seal (inner side) from gear housing assembly.

CAUTION:

Never damage gear housing assembly and cylinder inner wall. Gear housing assembly must be replaced if damaged because it may cause fluid leakage.

17. Perform inspection after disassembly. Refer to [ST-29. "Inspection"](#).

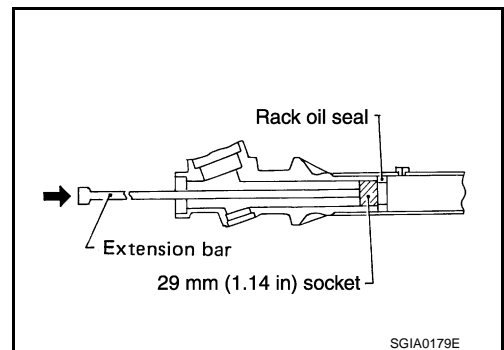

ASSEMBLY

CAUTION:

- Disassemble and assemble steering gear assembly by fixing the mounting area with a vise using copper plates.
- Clean steering gear assembly with kerosene before disassembling. Be careful to avoid splashing or applying any kerosene over connector of discharge port or return port.

1. Apply recommended fluid to O-ring, and then install O-ring to rack assembly.

CAUTION:

Never reuse O-ring.

STEERING GEAR AND LINKAGE

< REMOVAL AND INSTALLATION >

2. Apply recommended grease to rack oil seal, and then install rack oil seal in the following procedure. Then assemble rack assembly to gear housing assembly.

CAUTION:

- Install rack oil seal in a direction so that the lip of inner oil seal and the lip of outer oil seal face each other.
- Never damage retainer sliding surface by rack assembly. Replace gear housing assembly if damaged.
- Never damage gear housing assembly inner wall by rack assembly. Gear housing assembly must be replaced if damaged because it may cause fluid leakage.
- Never reuse rack oil seal.

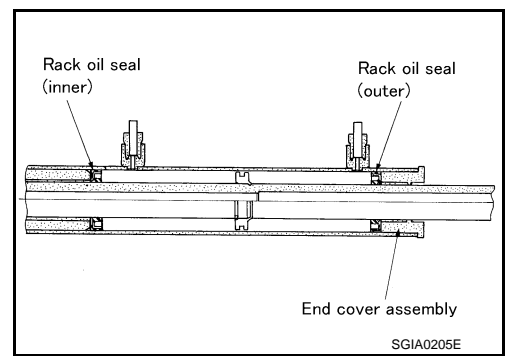

- a. Wrap an OHP sheet [approximately 70 mm (2.76 in) × 100 mm (3.94 in)]. Around rack assembly teeth to avoid damaging rack oil seal (inner). Install rack oil seal over sheet. Then, pull OHP sheet along with rack oil seal until they pass rack assembly teeth, and remove OHP sheet.

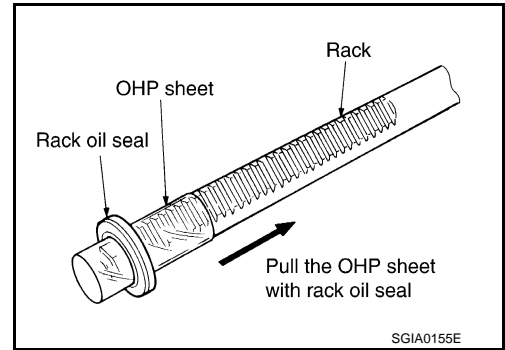

- b. Insert rack oil seal (inner) into rack assembly piston (rack Teflon ring).
- c. Push retainer to adjusting screw side by hand, and move the rack assembly inside the gear housing assembly so that the rack oil seal (inner) can be pressed against the gear housing assembly.

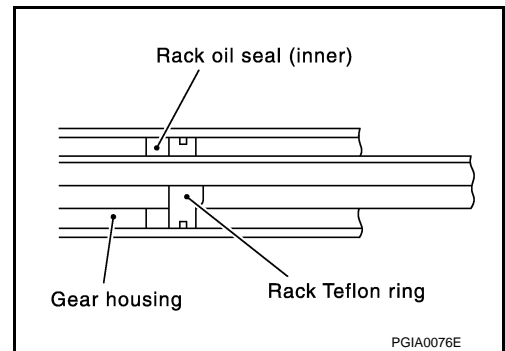

- d. Wrap an OHP sheet [approximately 70 mm (2.76 in) × 100 mm (3.94 in)]. Around the edge to avoid damaging rack oil seal (outer). Install rack oil seal over sheet. Then, pull oil seal along with OHP sheet until they pass rack edge, and remove OHP sheet.
- e. Apply recommended grease to rack spacer.
- f. Install end cover assembly and rack spacer to rack edge, and move rack oil seal (outer) until it contacts with gear housing assembly.

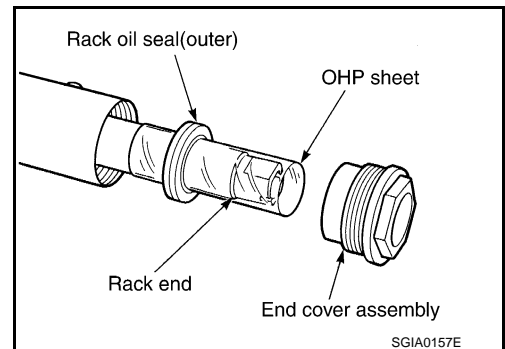

A
B
C
D
E
F
ST
H
I
J
K
L
M
N
O
P

STEERING GEAR AND LINKAGE

< REMOVAL AND INSTALLATION >

3. Tighten end cover assembly to specified torque using a 36 mm (1.42 in) open head (commercial service tool).

CAUTION:

Never damage rack assembly. Replace it if damaged because it may cause fluid leakage.

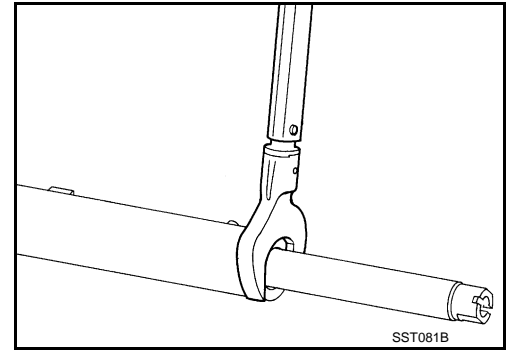

4. Crimp gear housing assembly at one point using a punch as shown in the figure so as to prevent end cover assembly from getting loose after tightening end cover assembly.

A : 2 – 3 mm (0.08 – 0.12 in)

5. Install gear-sub assembly to gear housing assembly.

CAUTION:

In order to protect oil seal from any damage, insert gear-sub assembly straightly.

6. Apply recommended fluid to O-ring, and then install O-ring to rear cover.

CAUTION:

Never reuse O-ring.

7. Install rear cover to gear-sub assembly, using the rear cover wrench (A) [SST: KV48105400 (—)]

CAUTION:

Never reuse rear cover.

8. Install inner socket to rack assembly with the following procedure.

- a. Install spacer to rack assembly.

- b. Apply thread sealant into the thread of inner socket.

Use Genuine High Strength Thread Locking Sealant or equivalent. Refer to [GI-22, "Recommended Chemical Products and Sealants"](#).

- c. Screw inner socket into rack part and tighten at the specified torque.

9. Decide on the neutral position of the rack stroke (L).

Rack stroke neutral position (L) : Refer to [ST-35, "Steering Gear and Linkage"](#).

10. Install rear cover cap to gear sub-assembly.

CAUTION:

Make sure that the projection of rear cover cap is aligned with the marking position of gear housing assembly.

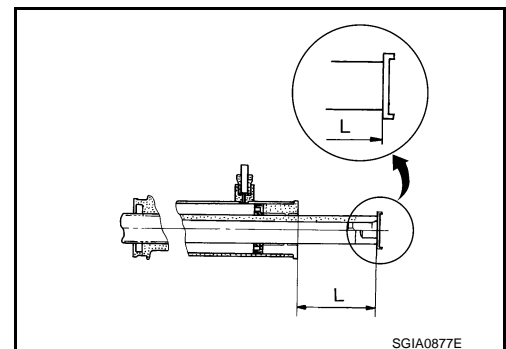
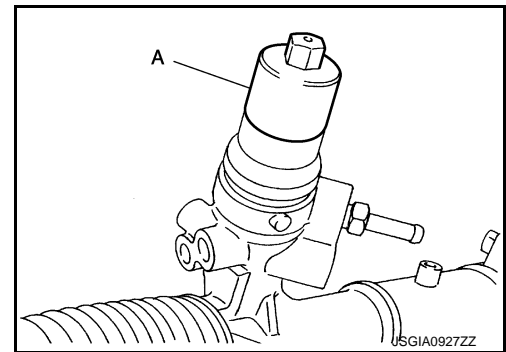
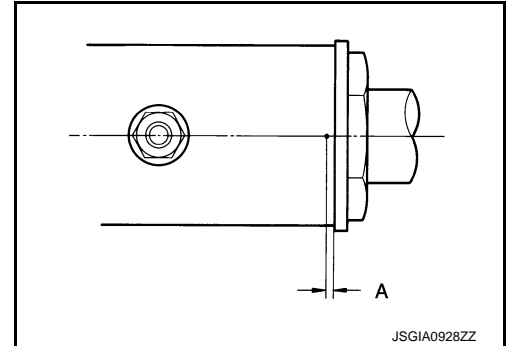

STEERING GEAR AND LINKAGE

< REMOVAL AND INSTALLATION >

11. Apply recommended thread sealant to the thread of adjusting screw (2 turns thread), and then screw in the adjusting screw until it reaches height "H" from gear housing assembly measured before disassembling.

Use Genuine High Performance Thread Sealant or equivalent. Refer to [GI-22. "Recommended Chemical Products and Sealants"](#).

12. Move rack assembly 10 strokes throughout the full stroke so that the parts can fit with each other.

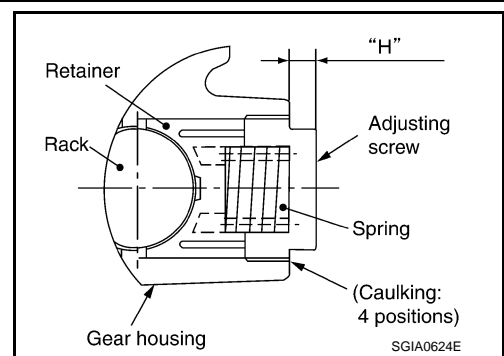

13. Adjust pinion rotating torque with the following procedure.
 - a. Measure pinion rotating torque within $\pm 180^\circ$ of neutral position of the rack assembly using Tools. Stop the gear at the point where highest torque is read.

A: Preload gauge [SST: ST3127S000 (J-25765-A)]

B: Preload adapter [SST: KV48103400 (—)]

- b. Loosen adjusting screw and retighten to 5.4 N·m (0.55 kg·m, 48 in·lb), and then loosen by 20 to 40°.

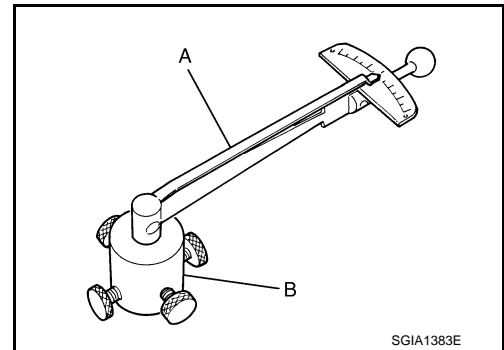

- c. Measure pinion rotating torque using tools to make sure that the measured value is within the standard. Readjust if the value is outside the standard. Replace steering gear assembly, if the value is outside the standard after readjusting, or adjusting screw rotating torque is 5 N·m (0.51 kg·m, 44 in·lb) or less.

Pinion rotating torque : Refer to [ST-35. "Steering Gear and Linkage"](#).

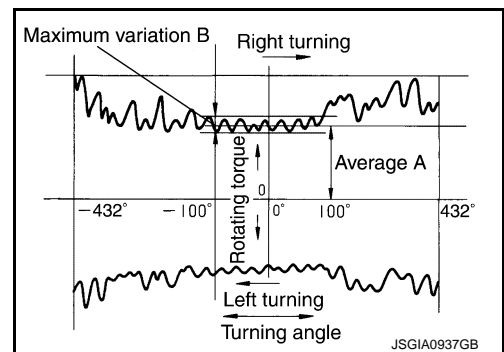

- d. Turn pinion fully to left.

- e. Install dial indicator at 5 mm (0.20 in) (L) from the edge of gear housing assembly (1), and tooth point.

- f. Measure vertical movement of rack assembly when pinion is turned clockwise with torque of 19.6 N·m (2.0 kg·m, 14 ft·lb).

Vertical movement : Refer to [ST-35. "Steering Gear and Linkage"](#).

- If reading is outside of the specification, readjust screw angle with adjusting screw.

CAUTION:

- Replace steering gear assembly when adjusting screw is removed or turned more than twice.

- Never turn adjusting screw more than twice.

- If reading is still outside of specification, or if the rotating torque of adjusting screw is less than 5 N·m (0.51 kg·m, 44 in·lb), replace steering gear assembly.

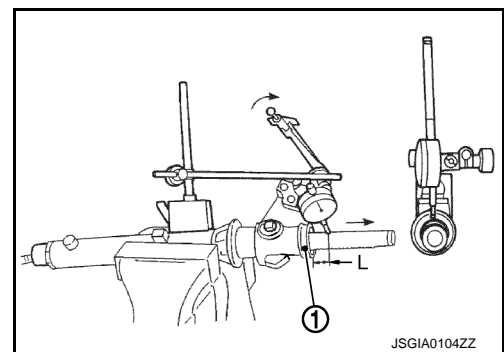

14. Install large end of boot to gear housing assembly.
15. Install small end of boot to inner socket boot mounting groove.
16. Install boot clamp to boot small end.
17. Install boot clamp to the large side of boot with the following procedure.

CAUTION:

Never reuse boot clamp.

STEERING GEAR AND LINKAGE

< REMOVAL AND INSTALLATION >

- a. Tighten large side of boot with boot clamp (stainless wire).

Wire length (L) : 390 mm (15.35 in)

- b. Wrap clamp around boot groove for two turns. Insert a flat-bladed screwdriver in loops on both ends of wire. Twist 4 to 4.5 turns while pulling them with force of approximately 98 N (10 kg, 22 lb).

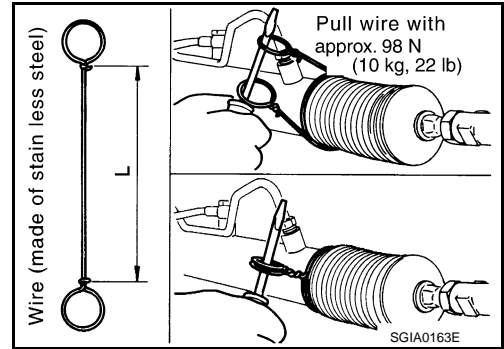

- c. Twist boot clamp as shown. Pay attention to relationship between winding and twisting directions.

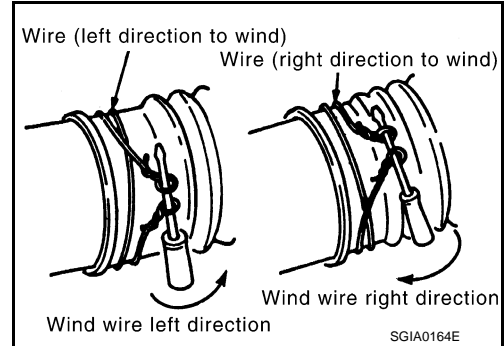

- d. Twisted area (A) of clamp is in the adjusting screw side (1) as shown in the figure (to prevent contact with other parts).

A : 80°

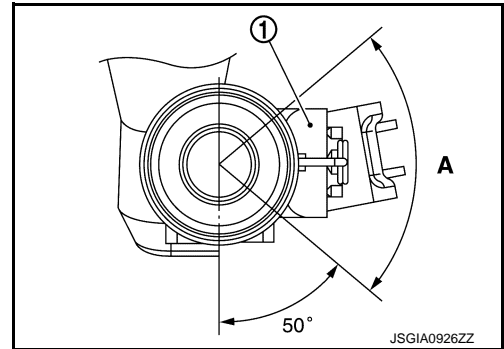

- e. Bent cut end of the wire toward rack axial as shown in the figure after twisting the wire 4 to 4.5 turns so that cut end does not contact with boot.

CAUTION:

Keep gap from cylinder tube 5 mm (0.20 in) or more.

A : 30°

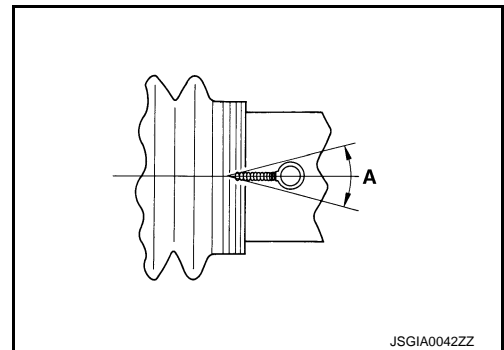

18. Install cylinder tubes to gear housing assembly.
19. Install low pressure piping.

20. Install outer socket with the following procedure.
• Adjust inner socket to standard length (L), and then tighten lock nut (1) to the specified torque. Check length again after tightening lock nut.

Inner socket length (L) : Refer to [ST-35, "Steering Gear and Linkage"](#).

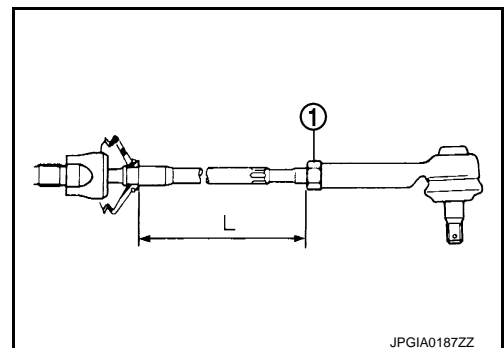

STEERING GEAR AND LINKAGE

< REMOVAL AND INSTALLATION >

CAUTION:

- When tightening the lock nut (1), be sure to fix outer socket (2) with a wrench or an equivalent to prevent the ball joint from getting contact with the knuckle.
- Adjust toe-in after this procedure. The length achieved after toe-in adjustment is not necessary the above value.

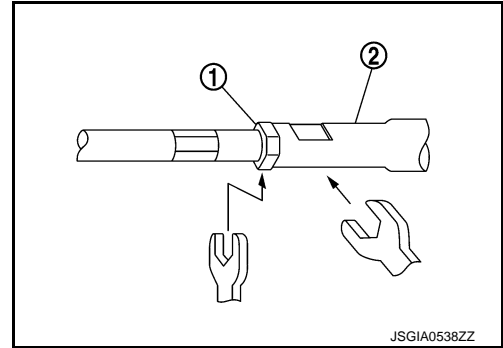

JSGIA0538ZZ

INFOID:000000007050607

Inspection

INSPECTION AFTER DISASSEMBLY

Boot

Check boot for cracks, and replace it if a malfunction is detected.

Rack Assembly

Check rack for damage or wear, and replace it if a malfunction is detected.

Gear-Sub Assembly

- Check gear-sub assembly for damage or wear, and replace it if a malfunction is detected.
- Rotate gear-sub assembly and check for torque variation or rattle, and replace it if a malfunction is detected.

Gear Housing Assembly

Check gear housing assembly for damage and scratches (inner wall). Replace if there are.

Outer Socket and Inner Socket

Check the following items and replace the component if it does not meet the standard.

BALL JOINT SWINGING FORCE

Hook a spring balance at the point and pull the spring balance. Make sure that the spring balance reads the specified value when ball stud and inner socket start to move. Replace outer socket and inner socket if they are outside the standard.

Measuring point of outer socket (1) : Ball stud upper side (A)

Measuring point of inner socket (2) : Point (B) shown in the figure

Swinging force (Spring balance measurement) : Refer to [ST-35. "Steering Gear and Linkage"](#).

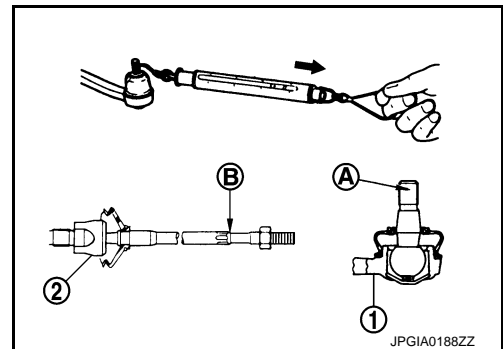

BALL JOINT ROTATING TORQUE

Make sure that the reading is within the following specified range using preload gauge (A) [SST: ST3127S000 (J-25765-A)]. Replace outer socket if the reading is outside the specified value.

Rotating torque : Refer to [ST-35. "Steering Gear and Linkage"](#).

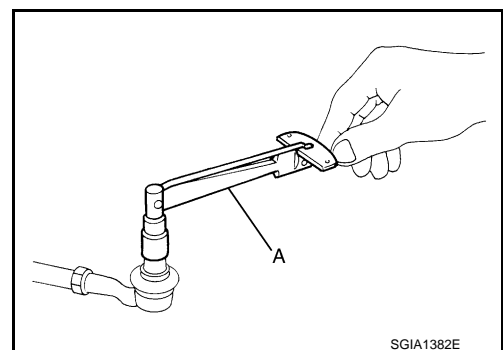

BALL JOINT AXIAL END PLAY

STEERING GEAR AND LINKAGE

< REMOVAL AND INSTALLATION >

Apply an axial load of 490 N (50 kg, 110 lb) to ball stud. Using a dial indicator, measure amount of stud movement, and then make sure that the value is within the following specified range. Replace outer socket (1) and inner socket (2) if the measured value is outside the standard.

Axial end play : Refer to [ST-35, "Steering Gear and Linkage"](#).

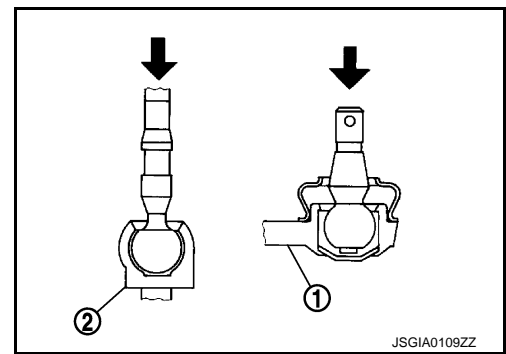

INSPECTION AFTER INSTALLATION

- Check if steering wheel turns smoothly when it is turned several times fully to the end of the left and right.
- Check the steering wheel play, neutral position steering wheel, steering wheel turning torque, and front wheel turning angle.
 - Steering wheel play: Refer to [ST-10, "Inspection"](#).
 - Neutral position steering wheel, steering wheel turning torque, and front wheel turning angle: Refer to [ST-5, "Inspection"](#).
- Bleed the hydraulic system. Refer to [ST-8, "Inspection"](#).
- Check the fluid level and check for leakage. Refer to [ST-8, "Inspection"](#).
- Check wheel alignment. Refer to [FSU-6, "Inspection"](#).
- Adjust neutral position of steering angle sensor. Refer to [BRC-48, "Work Procedure"](#).

POWER STEERING OIL PUMP

< REMOVAL AND INSTALLATION >

POWER STEERING OIL PUMP

Exploded View

INFOID:000000007050612

POWER STEERING OIL PUMP ASSEMBLY: IRON COVER TYPE

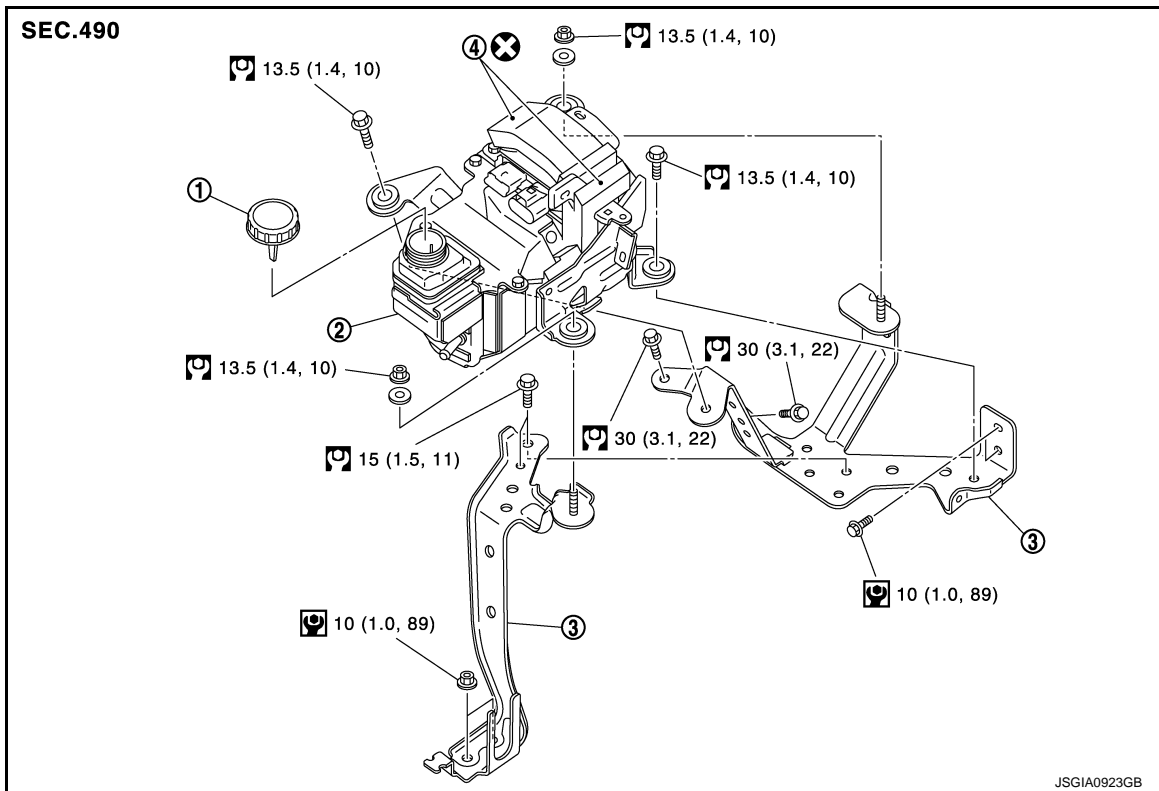

1. Reservoir cap

2. Power steering oil pump assembly

3. Bracket

4. Noise insulator

: N·m (kg-m, in-lb)

: N·m (kg-m, ft-lb)

: Always replace after every disassembly.

POWER STEERING OIL PUMP ASSEMBLY: RESIN COVER TYPE

POWER STEERING OIL PUMP

< REMOVAL AND INSTALLATION >

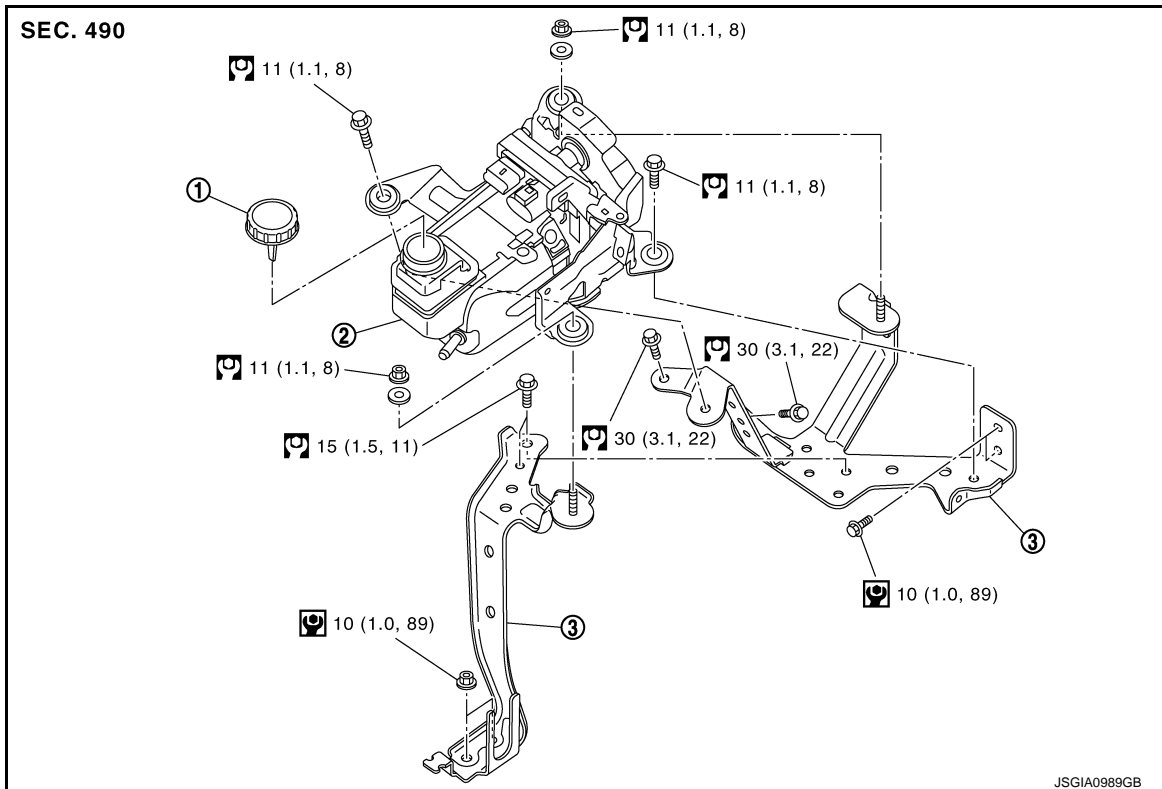

1. Reservoir cap 2. Power steering oil pump assembly 3. Bracket

: N-m (kg-m, in-lb)

: N-m (kg-m, ft-lb)

: Always replace after every disassembly.

Removal and Installation

INFOID:000000007050613

REMOVAL

CAUTION:

- **Disconnect the battery negative terminal before performing the work.**
- **Noise insulator is function part, never remove. (Iron cover type)**

1. Remove reservoir tank of radiator. Refer to [CO-13, "Exploded View"](#).
2. Remove washer tank inlet. Refer to [WW-55, "Exploded View"](#).
3. Disconnect each connector and grand cable from power steering control module.
4. Remove high-pressure flexible hose. Refer to [HA-34, "HIGH-PRESSURE FLEXIBLE HOSE : Removal and Installation"](#).
5. Remove return hose, and drain power steering fluid.
CAUTION:
 - **Never reuse drained power steering fluid.**
 - **Always use the specified fluid. Refer to [MA-10, "Fluids and Lubricants"](#).**
6. Remove high-pressure piping and O-ring. Refer to [ST-34, "Exploded View"](#).
7. Remove food side cover. Refer to [DLK-423, "Exploded View"](#).
8. Remove oil pump assembly mounting bolts and nuts, and then remove oil pump assembly.
9. Remove brackets.
10. Perform inspection after removal. Refer to [ST-33, "Inspection"](#).

INSTALLATION

Note the following, and install in the reverse order of removal.

- When installing high-pressure piping, securely install O-ring to high-pressure piping.

POWER STEERING OIL PUMP

< REMOVAL AND INSTALLATION >

CAUTION:

Never reuse O-ring.

- When installing return hoses, refer to the figure.

CAUTION:

- **Never apply fluid to the hose (1) and tube (2).**
- **Insert hose securely until it contacts spool (A) of tube.**
- **Leave clearance (L) when installing clamp (3).**

L : 3 – 8 mm (0.12 – 0.31 in)

- If noise insulator is removed, clean mounting surface, and install new noise insulator. (Iron cover type)

CAUTION:

Never reuse noise insulator.

- Perform inspection after installation. Refer to [ST-33, "Inspection"](#).

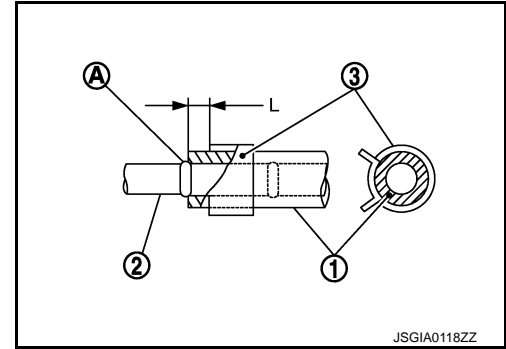

Inspection

INFOID:000000007050615

INSPECTION AFTER REMOVAL

Check oil pump assembly for damage or other malfunctions. Replace if necessary.

INSPECTION AFTER INSTALLATION

- Check oil pump assembly for damage or other malfunctions. Replace if necessary.
- Check the fluid level and check for leakage. Refer to [ST-8, "Inspection"](#).
- Bleed the hydraulic system. Refer to [ST-8, "Inspection"](#).

RELIEF OIL PRESSURE

1. Connect the oil pressure gauge (A) [SST: KV48103500 (J-26357)] and the adapter set (B) [SST: KV481059S0 (—)] between oil pump discharge port and high-pressure piping. Bleed air from the hydraulic circuit while opening valve fully.

CAUTION:

Check that O-ring is installed on adapter (male side) [SST: KV48105920 (—)].

2. Start the engine and adjust the reservoir tank oil temperature to room temperature [recommended oil temperature: approximately 20°C (68°F)].

CAUTION:

Leave the valve of the oil pressure gauge fully open while starting and running engine. If engine is started with the valve closed, the hydraulic pressure in oil pump goes up to the relief pressure along with unusual increase of oil temperature.

3. Fully close the oil pressure gauge valve with engine at idle and measure the relief oil pressure.

Relief oil pressure : Refer to [ST-36, "Oil Pump"](#).

CAUTION:

Never keep valve closed for 10 seconds or longer.

4. Open the valve slowly after measuring. Replace oil pump if the relief oil pressure is outside the standard.
5. Disconnect the oil pressure gauge and adapters from hydraulic circuit.
6. Connect high-pressure piping with O-ring to oil pump assembly.

CAUTION:

Never reuse O-ring.

7. Check fluid level, fluid leakage and air bleeding hydraulic system after the installation. Refer to [ST-8, "Inspection"](#).

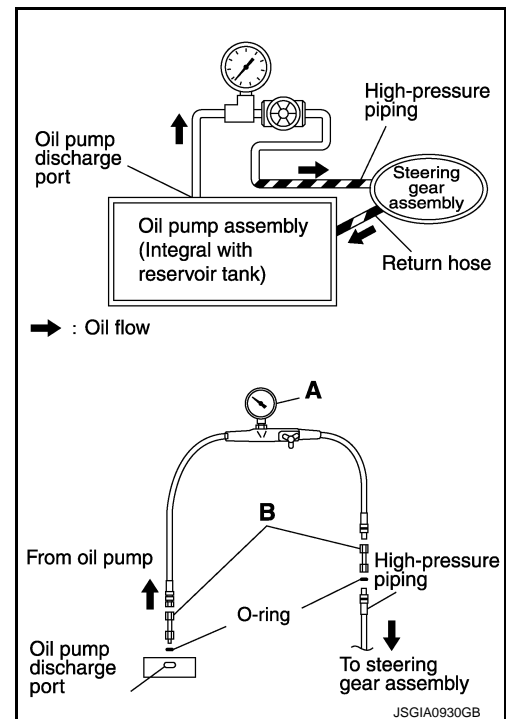

HYDRAULIC LINE

< REMOVAL AND INSTALLATION >

HYDRAULIC LINE

Exploded View

INFOID:000000007050620

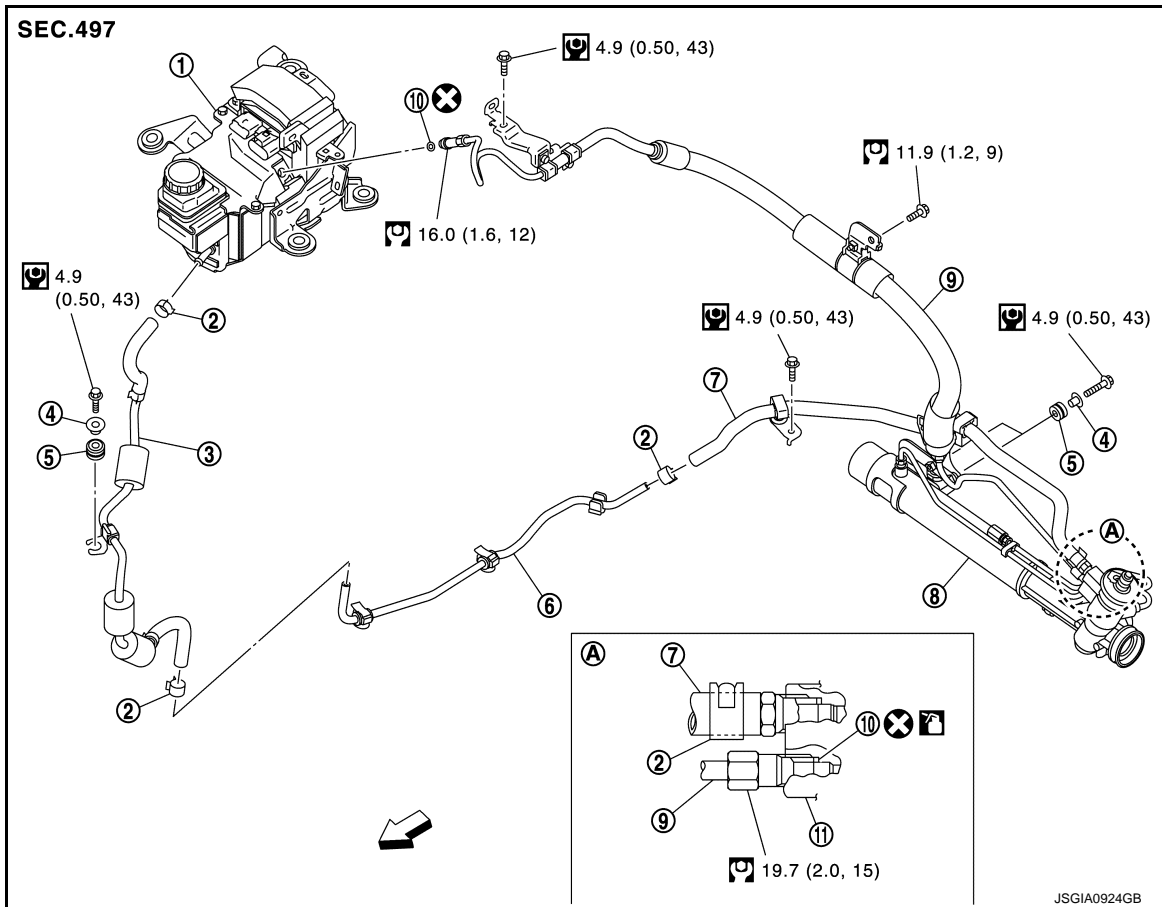

- | | | |
|-------------------------------------|---------------------------|-------------------------|
| 1. Power steering oil pump assembly | 2. Clamp | 3. Return hose assembly |
| 4. Collar | 5. Bushing | 6. Return tube |
| 7. Return hose | 8. Steering gear assembly | 9. High pressure piping |
| 10. O-ring | 11. Gear housing assembly | |

A. Location in steering gear assembly

↔: Vehicle front

: N-m (kg-m, in-lb)

: N-m (kg-m, ft-lb)

: Always replace after every disassembly.

SERVICE DATA AND SPECIFICATIONS (SDS)

< SERVICE DATA AND SPECIFICATIONS (SDS)

SERVICE DATA AND SPECIFICATIONS (SDS)

SERVICE DATA AND SPECIFICATIONS (SDS)

General Specifications

INFOID:000000007136403

Steering gear model	PR26AM
Fluid capacity (Approx.)	ℓ (US qt, Imp qt) 1.0 (1-1/8, 7/8)

Steering Wheel

INFOID:000000007136404

Item	Standard
Steering wheel axial end play	0 mm (0 in)
Steering wheel play on the outer circumference	0 – 35 mm (0 – 1.38 in)
Steering wheel turning torque	7.45 N·m (0.76 kg·m, 66 in-lb)

Steering Angle

INFOID:000000007136405

		Unit: Degree minute (Decimal degree)
Item		Standard
Inner wheel	Minimum	39° 00' (39.0°)
	Nominal	42° 00' (42.0°)
	Maximum	43° 00' (43.0°)
Outer wheel	Nominal	36° 00' (36.0°)

Steering Column

INFOID:000000007136406

Item	Standard
Rotating torque	0.49 N·m (0.05 kg·m, 4 in-lb) or less
Steering column length*	416 – 420 mm (16.38 – 16.54 in)
Impact displacement absorption part dimension*	95.3 – 97.3 mm (3.752 – 3.831 in)
Tilt operating range*	46 mm (1.81 in)
Telescopic operating range*	40 mm (1.57 in)

*: For measuring position, refer to [ST-13. "Inspection"](#).

Intermediate Shaft

INFOID:000000007136407

Item	Standard
Shaft length*	630.7 – 638.5 mm (24.83 – 25.14 in)
Shaft sliding range*	80 mm (3.15 in)

*: For measuring position, refer to [ST-17. "Inspection"](#).

Steering Gear and Linkage

INFOID:000000007136408

Item		Standard
Pinion rotating torque*	Around neutral position (within ±100°) Average	1.59 – 2.0 N·m (0.17 – 0.20 kg·m, 14 – 17 in-lb)
	Maximum variation	0.98 N·m (0.10 kg·m, 9 in-lb)
Rack sliding force		226 – 285 N (23.1 – 29.0 kg-f, 50.1 – 64.0 lb-f)

SERVICE DATA AND SPECIFICATIONS (SDS)

< SERVICE DATA AND SPECIFICATIONS (SDS)

Item		Standard
Rack vertical movement	Rack axial direction Measuring position: At 5 mm (0.20 in) from the edge of gear housing assembly	0.265 mm (0.0104 in) or less
	Rack turning direction Measuring position: At adjusting screw axial direction	0.265 mm (0.0104 in) or less
Outer socket ball joint	Swing force* (Spring balance measurement)	4.41 – 42.7 N (0.45 – 4.35 kg-f, 1.0 – 9.59 lb-f)
	Rotating torque	0.3 – 2.9 N·m (0.03 – 0.29 kg-m, 3 – 25 in-lb)
	Axial end play	0.5 mm (0.020 in) or less
Inner socket ball joint	Swing force* (Spring balance measurement)	7.2 – 56.1 N (0.74 – 5.72 kg-f, 1.62 – 12.61 lb-f)
	Axial end play	0.2 mm (0.008 in) or less
Inner socket length		120 mm (4.72 in) or less
Rack stroke neutral position		79.0 mm (3.110 in)

*: For measuring position, refer to [ST-29, "Inspection"](#).

Oil Pump

INFOID:000000007136409

Unit: kPa (kg/cm², psi)

Item		Standard
Relief oil pressure	Oil pump assembly: Iron cover type	9,700 – 10,300 (99 – 105, 1,407 – 1,493)
	Oil pump assembly: Resin cover type	9,900 – 10,400 (101 – 106, 1,436 – 1,508)