

A  
CO  
C  
D  
E  
F  
G  
H  
I  
J  
K  
L  
M  
N  
O  
P

# SECTION CO

## ENGINE COOLING SYSTEM

### CONTENTS

<b>SYSTEM DESCRIPTION</b> .....	<b>REMOVAL AND INSTALLATION</b> .....	
<b>DESCRIPTION</b> .....	<b>RADIATOR</b> .....	
Engine Cooling System .....	Exploded View .....	
Engine Cooling System Schematic .....	Removal and Installation .....	
<b>SYMPTOM DIAGNOSIS</b> .....	Inspection .....	
<b>OVERHEATING CAUSE ANALYSIS</b> .....	<b>COOLING FAN</b> .....	
Troubleshooting Chart .....	Exploded View .....	
<b>PRECAUTION</b> .....	Removal and Installation .....	
<b>PRECAUTIONS</b> .....	Disassembly and Assembly .....	
Precaution for Supplemental Restraint System (SRS) "AIR BAG" and "SEAT BELT PRE-TEN- SIONER" .....	Inspection .....	
Liquid Gasket .....	<b>WATER PUMP</b> .....	
<b>PREPARATION</b> .....	Exploded View .....	
<b>PREPARATION</b> .....	Removal and Installation .....	
Special Service Tool .....	Inspection .....	
Commercial Service Tools .....	<b>WATER INLET AND THERMOSTAT ASSEM- BLY</b> .....	
<b>PERIODIC MAINTENANCE</b> .....	Exploded View .....	
<b>ENGINE COOLANT</b> .....	Removal and Installation .....	
Inspection .....	Inspection .....	
Draining .....	<b>WATER OUTLET AND WATER PIPING</b> .....	
Refilling .....	Exploded View .....	
Flushing .....	Removal and Installation .....	
<b>RADIATOR</b> .....	Inspection .....	
<b>RADIATOR CAP</b> .....	<b>SERVICE DATA AND SPECIFICATIONS (SDS)</b> .....	
RADIATOR CAP : Inspection .....	<b>SERVICE DATA AND SPECIFICATIONS (SDS)</b> .....	
<b>RADIATOR</b> .....	Periodical Maintenance Specification .....	
RADIATOR : Inspection .....	Radiator .....	
	Thermostat .....	

# DESCRIPTION

< SYSTEM DESCRIPTION >

## SYSTEM DESCRIPTION

### DESCRIPTION

#### Engine Cooling System

INFOID:000000008380742

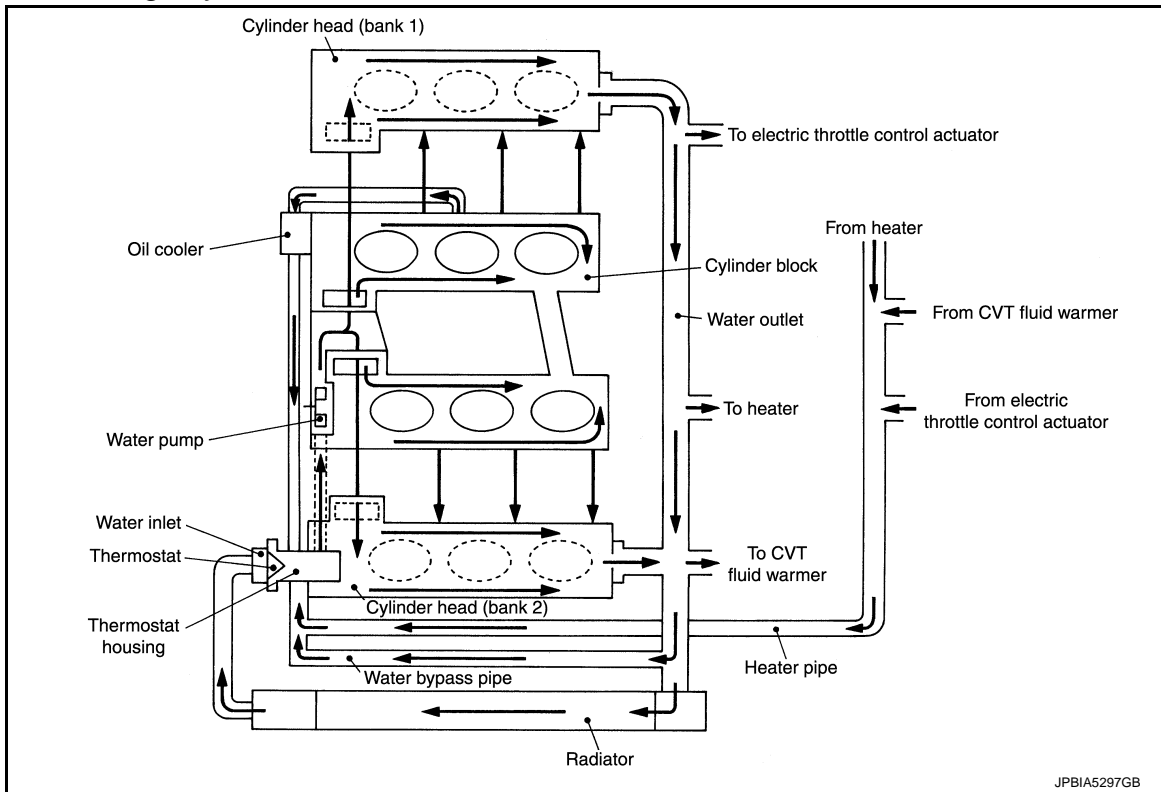

#### Engine Cooling System Schematic

INFOID:000000008380743

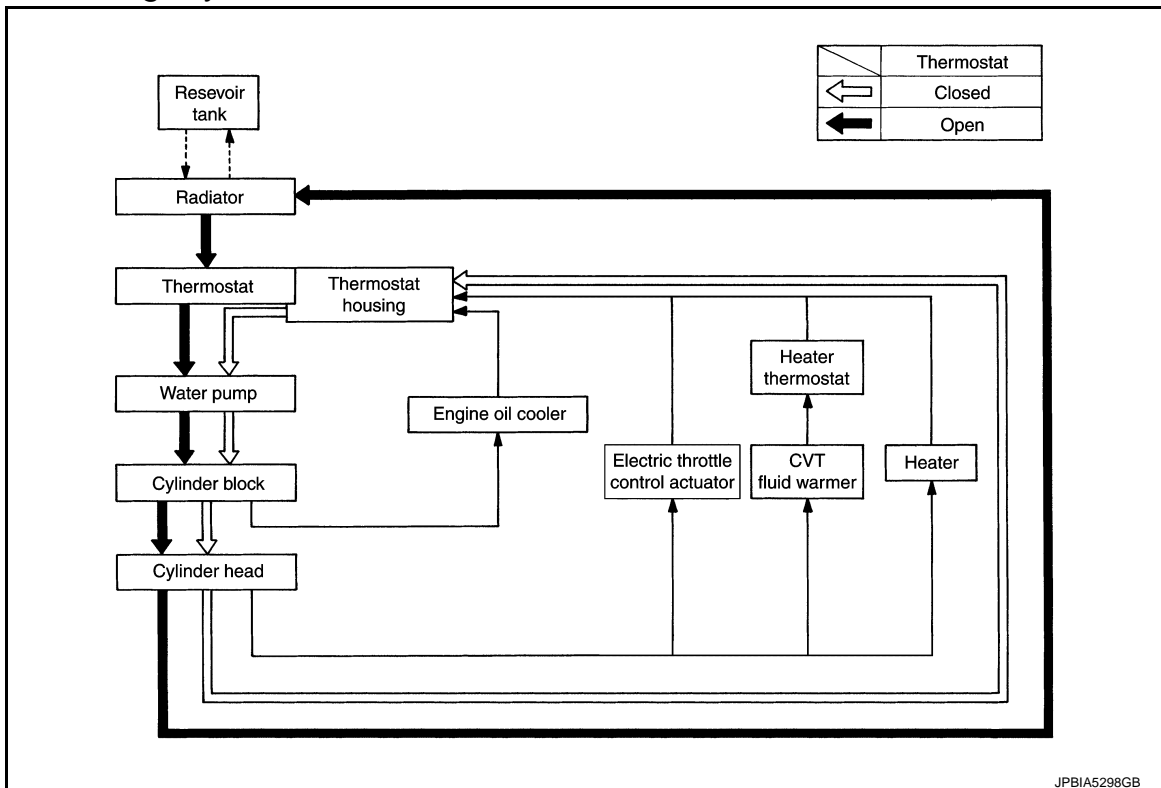

# OVERHEATING CAUSE ANALYSIS

< SYMPTOM DIAGNOSIS >

## SYMPTOM DIAGNOSIS

### OVERHEATING CAUSE ANALYSIS

#### Troubleshooting Chart

INFOID:000000008380744

A

CO

		Symptom	Check items	
Cooling system parts malfunction	Poor heat transfer	Water pump malfunction	Worn or loose drive belt	—
		Thermostat stuck closed	—	
		Damaged fins	Dust contamination or paper clogging	
			Physical damage	
		Clogged radiator cooling tube	Excess foreign material (rust, dirt, sand, etc.)	
	Reduced air flow	Cooling fan does not operate	Fan assembly	—
		High resistance to fan rotation		
		Damaged fan blades		
		Damaged radiator shroud	—	—
		Improper engine coolant mixture ratio	—	—
		Poor engine coolant quality	—	Engine coolant density
	Insufficient engine coolant	Engine coolant leakage	Cooling hose	Loose clamp
				Cracked hose
			Water pump	Poor sealing
			Radiator cap	Loose
Poor sealing				
Radiator			O-ring for damage, deterioration or improper fitting	
		Cracked radiator tank		
		Cracked radiator core		
		Reservoir tank	Cracked reservoir tank	
Overflowing reservoir tank	Exhaust gas leakage into cooling system	Cylinder head deterioration		
		Cylinder head gasket deterioration		

C

D

E

F

G

H

I

J

K

L

M

N

O

P

# OVERHEATING CAUSE ANALYSIS

## < SYMPTOM DIAGNOSIS >

		Symptom		Check items	
Except cooling system parts malfunction	—	Overload on engine	Abusive driving	High engine rpm under no load	—
				Driving in low gear for extended time	
				Driving at extremely high speed	
			Powertrain system malfunction		
			Installed improper size wheels and tires		
			Dragging brakes		
	Blocked or restricted air flow	Blocked or restricted air flow	Blocked bumper	—	—
			Blocked radiator grille	Installed car brassiere	
				Mud contamination or paper clogging	
			Blocked radiator	—	
Blocked condenser			Blocked air flow		
Installed large fog lamp					

# PRECAUTIONS

< PRECAUTION >

## PRECAUTION

### PRECAUTIONS

#### Precaution for Supplemental Restraint System (SRS) "AIR BAG" and "SEAT BELT PRE-TENSIONER"

INFOID:000000008380745

The Supplemental Restraint System such as "AIR BAG" and "SEAT BELT PRE-TENSIONER", used along with a front seat belt, helps to reduce the risk or severity of injury to the driver and front passenger for certain types of collision. This system includes seat belt switch inputs and dual stage front air bag modules. The SRS system uses the seat belt switches to determine the front air bag deployment, and may only deploy one front air bag, depending on the severity of a collision and whether the front occupants are belted or unbelted. Information necessary to service the system safely is included in the "SRS AIR BAG" and "SEAT BELT" of this Service Manual.

#### **WARNING:**

Always observe the following items for preventing accidental activation.

- To avoid rendering the SRS inoperative, which could increase the risk of personal injury or death in the event of a collision that would result in air bag inflation, all maintenance must be performed by an authorized NISSAN/INFINITI dealer.
- Improper maintenance, including incorrect removal and installation of the SRS, can lead to personal injury caused by unintentional activation of the system. For removal of Spiral Cable and Air Bag Module, see "SRS AIR BAG".
- Never use electrical test equipment on any circuit related to the SRS unless instructed to in this Service Manual. SRS wiring harnesses can be identified by yellow and/or orange harnesses or harness connectors.

#### PRECAUTIONS WHEN USING POWER TOOLS (AIR OR ELECTRIC) AND HAMMERS

#### **WARNING:**

Always observe the following items for preventing accidental activation.

- When working near the Air Bag Diagnosis Sensor Unit or other Air Bag System sensors with the ignition ON or engine running, never use air or electric power tools or strike near the sensor(s) with a hammer. Heavy vibration could activate the sensor(s) and deploy the air bag(s), possibly causing serious injury.
- When using air or electric power tools or hammers, always switch the ignition OFF, disconnect the battery, and wait at least 3 minutes before performing any service.

#### Liquid Gasket

INFOID:000000008380746

#### REMOVAL OF LIQUID GASKET SEALING

- After removing mounting nuts and bolts, separate the mating surface using the seal cutter [SST: KV10111100 (J-37228)] (A) and remove old liquid gasket sealing.

#### **CAUTION:**

Be careful not to damage the mating surfaces.

- Tap (B) the seal cutter [SST: KV10111100 (J-37228)] to insert it, and then slide (C) it by tapping on the side as shown in the figure.
- In areas where seal cutter [SST: KV10111100 (J-37228)] is difficult to use, use a plastic hammer to lightly tap the parts, to remove it.

#### **CAUTION:**

If for some unavoidable reason tool such as a screwdriver is used, be careful not to damage the mating surfaces.

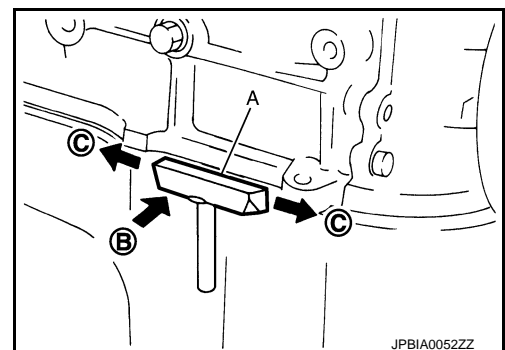

JPBIA0052ZZ

#### LIQUID GASKET APPLICATION PROCEDURE

# PRECAUTIONS

## < PRECAUTION >

1. Using a scraper (A), remove old liquid gasket adhering to the liquid gasket application surface and the mating surface.
  - Remove liquid gasket completely from the groove of the liquid gasket application surface, mounting bolts, and bolt holes.
2. Wipe the liquid gasket application surface and the mating surface with white gasoline (lighting and heating use) to remove adhering moisture, grease and foreign materials.

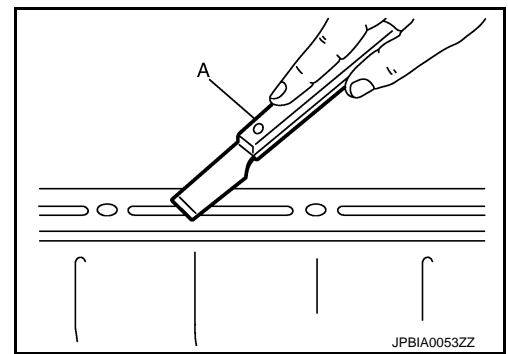

3. Attach liquid gasket tube to the tube presser (commercial service tool).  
**Use Genuine RTV Silicone Sealant or equivalent. Refer to [GI-22, "Recommended Chemical Products and Sealants"](#).**
4. Apply liquid gasket without breaks to the specified location with the specified dimensions.
  - If there is a groove for the liquid gasket application, apply liquid gasket to the groove.

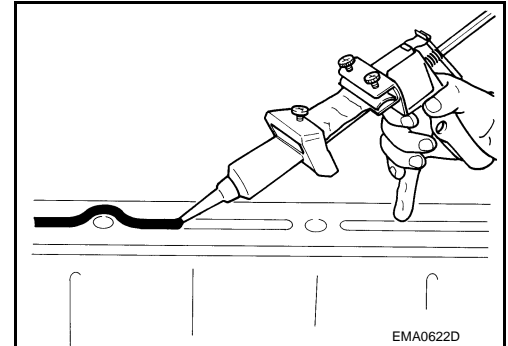

- As for the bolt holes (B), normally apply liquid gasket inside the holes. Occasionally, it should be applied outside the holes. Check to read the text of service manual.

A : Groove

⇐ : Inside

- Within five minutes of liquid gasket application, install the mating component.
- If liquid gasket protrudes, wipe it off immediately.
- Never retighten after mounting bolts and nuts the installation.
- After 30 minutes or more have passed from the installation, fill engine oil and engine coolant.

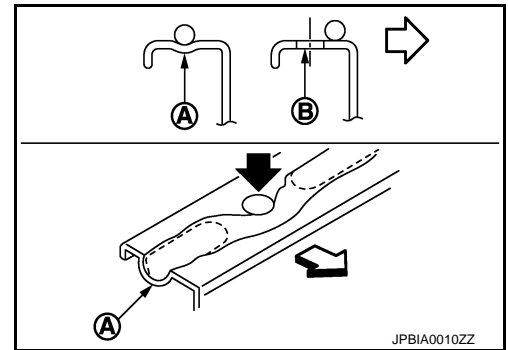

### CAUTION:

If there are specific instructions in this manual, observe them.

# PREPARATION

< PREPARATION >

## PREPARATION

### PREPARATION

#### Special Service Tool

INFOID:000000008380747

A

CO

The actual shapes of Kent-Moore tools may differ from those of special service tools illustrated here.

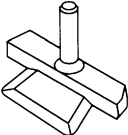
Tool number (Kent-Moore No.) Tool name	Description
KV10111100 (J-37228) Seal cutter   NT046	Removing water pump cover

C

D

E

#### Commercial Service Tools

INFOID:000000008380748

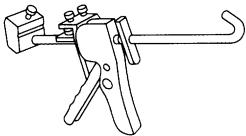
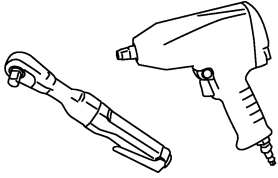
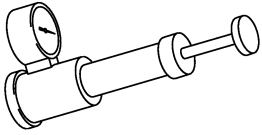
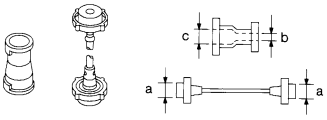
Tool name	Description
Tube presser   S-NT052	Pressing the tube of liquid gasket
Power tool   PBIC0190E	Loosening nuts and bolts
Radiator cap tester   PBIC1982E	Checking radiator and radiator cap
Radiator cap tester adapter   S-NT564	Adapting radiator cap tester to radiator cap and radiator pipe (upper) filler neck <b>a: 28 (1.10) dia.</b> <b>b: 31.4 (1.236) dia.</b> <b>c: 41.3 (1.626) dia.</b> Unit: mm (in)

F

G

H

I

J

K

L

M

N

O

P

# ENGINE COOLANT

< PERIODIC MAINTENANCE >

## PERIODIC MAINTENANCE

### ENGINE COOLANT

#### Inspection

INFOID:000000008380749

#### LEVEL

- Check if the reservoir tank engine coolant level is within the “MIN” to “MAX” when the engine is cool.

A : MAX

B : MIN

- Adjust the engine coolant level if necessary.

#### CAUTION:

Refill Genuine NISSAN Long Life Antifreeze/Coolant (blue) or equivalent in its quality mixed with water (distilled or demineralized). Refer to [MA-10, "Fluids and Lubricants"](#).

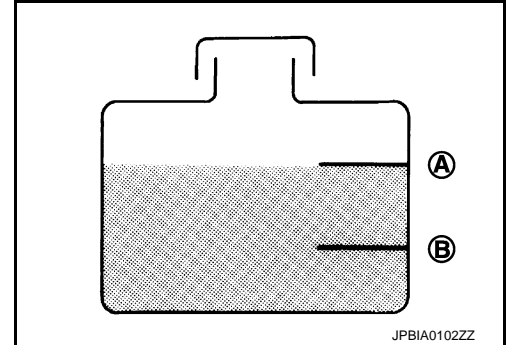

#### LEAKAGE

- To check for leakage, apply pressure to the cooling system with the radiator cap tester (commercial service tool) (A) and radiator cap tester adapter (commercial service tool) (B).

Testing pressure : Refer to [CO-28, "Radiator"](#).

#### WARNING:

Never remove radiator cap when engine is hot. Serious burns could occur from high-pressure engine coolant escaping from engine cooling system.

#### CAUTION:

Higher test pressure than specified may cause radiator damage.

#### NOTE:

In a case that engine coolant decreases, replenish radiator with engine coolant.

- If anything is found, repair or replace damaged parts.

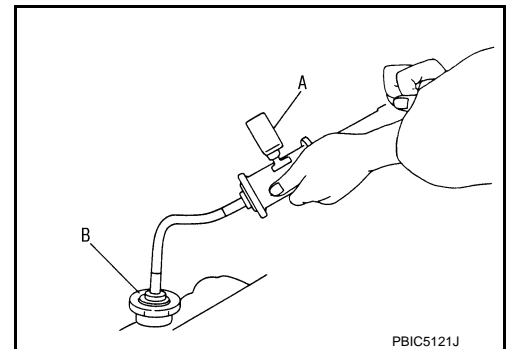

#### Draining

INFOID:000000008380750

#### WARNING:

- To avoid being scalded, never change engine coolant when the engine is hot.
- Wrap a thick cloth around radiator cap and carefully remove radiator cap. First, turn radiator cap a quarter of a turn to release built-up pressure. Then turn radiator cap all the way.

1. Remove engine under cover.
2. Open radiator drain plug (1) at the bottom of radiator, and then remove radiator cap.

← : Vehicle front

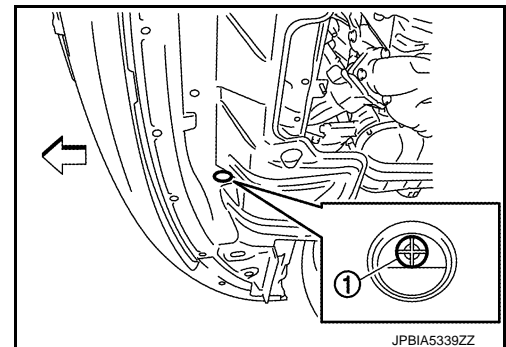

When draining all of engine coolant in the system, open water drain plugs on cylinder block. Refer to [EM-63, "Setting"](#).

3. Remove reservoir tank if necessary, and drain engine coolant and clean reservoir tank before installing.



# ENGINE COOLANT

## < PERIODIC MAINTENANCE >

4. Check drained engine coolant for contaminants such as rust, corrosion or discoloration.  
If contaminated, flush the engine cooling system. Refer to [CO-10, "Flushing"](#).

### Refilling

INFOID:000000008380751

#### CAUTION:

- Do not reuse O-rings.
- Do not put additive such as water leak preventive, since it may cause cooling waterway clogging.
- When refilling use Genuine NISSAN Long Life Antifreeze/Coolant (blue) or equivalent in its quality mixed with water (distilled or demineralized). Refer to [MA-10, "Fluids and Lubricants"](#).

1. Install reservoir tank if removed and radiator drain plug.

#### CAUTION:

Be sure to clean drain plug and install with new O-ring.

**Tightening torque** : Refer to [CO-13, "Exploded View"](#).

If water drain plugs on cylinder block are removed, close and tighten them. Refer to [EM-105, "Disassembly and Assembly"](#).

2. Check that each hose clamp has been firmly tightened.
3. Remove air duct assembly and air cleaner cases (upper and lower) assembly. Refer to [EM-26, "Exploded View"](#).
4. Remove air bleeder plug (1) of heater pipe.

← : Vehicle front

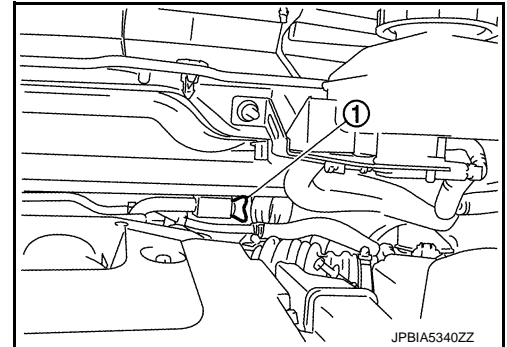

5. Fill radiator, and reservoir tank if removed, to specified level.

#### CAUTION:

Never adhere the engine coolant to electronic equipments. (alternator etc.)

- Pour engine coolant through engine coolant filler neck slowly of less than 2 l (2-1/8 US qt, 1-3/4 Imp qt) a minute to allow air in system to escape.
- When coolant comes out from the air bleeder plug of heater pipe, tighten the bleeder plug.

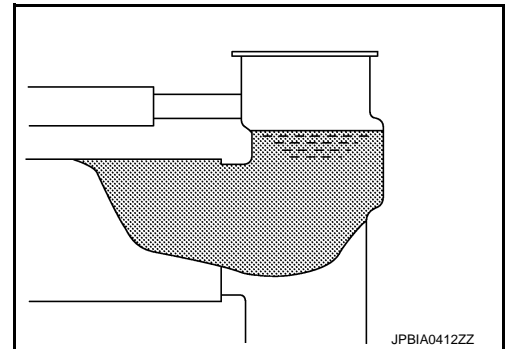

**Engine coolant capacity**  
(With reservoir tank at "MAX" level)

: Refer to [CO-28, "Periodical Maintenance Specification"](#).

**Reservoir tank engine coolant capacity**  
(At "MAX" level)

: Refer to [CO-28, "Periodical Maintenance Specification"](#).

# ENGINE COOLANT

< PERIODIC MAINTENANCE >

A : MAX  
B : MIN

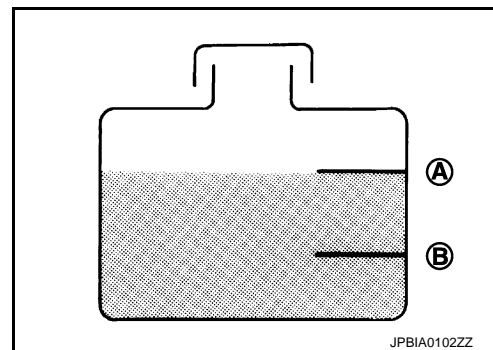

6. Install air duct assembly and air cleaner cases (upper and lower) assembly. Refer to [EM-26, "Exploded View"](#).
  7. Install radiator cap.
  8. Start the engine.
  9. Maintain the engine at 1,800 rpm for approximately 10 seconds. After performing this, stop the engine.
  10. Remove radiator cap with the engine cold (approx. 50°C or less), and check the cooling water level. If the fluid level is low, refill with cooling water to the lip of radiator.
  11. Repeat Steps from 7 to 9 four times.
  12. Cap the radiator, and start the engine.
  13. Warm up engine until opening thermostat. Standard for warming-up time is approximately 10 minutes at 3,000 rpm.
    - Check thermostat opening condition by touching radiator hose (lower) to see a flow of warm water.
- CAUTION:**  
**Watch water temperature gauge so as not to overheat engine.**
14. Stop the engine and cool down to less than approximately 50°C (122°F).
    - Cool down using fan to reduce the time.
    - If necessary, refill radiator up to filler neck with engine coolant.
- CAUTION:**  
**Never adhere the engine coolant to electronic equipments. (alternator etc.)**
15. Refill reservoir tank to "MAX" level line with engine coolant.
  16. Repeat steps 7 through 10 two or more times with radiator cap installed until engine coolant level no longer drops.
  17. Check cooling system for leakage with engine running.
  18. Warm up the engine, and check for sound of engine coolant flow while running engine from idle up to 3,000 rpm with heater temperature controller set at several position between "COOL" and "WARM".
    - Sound may be noticeable at heater unit.
  19. Repeat step 13 three times.
  20. If sound is heard, bleed air from cooling system by repeating step 5, and steps from 7 to 14 until engine coolant level no longer drops.

## Flushing

INFOID:000000008380752

1. Install reservoir tank if removed and radiator drain plug.

**CAUTION:**  
**Be sure to clean drain plug and install with new O-ring.**

**Tightening torque** : Refer to [CO-13, "Exploded View"](#).

**If water drain plugs on cylinder block are removed, close and tighten them. Refer to [EM-105, "Disassembly and Assembly"](#).**

2. Remove air duct assembly and air cleaner cases (upper and lower) assembly. Refer to [EM-26, "Exploded View"](#).
3. Remove air bleeder plug.
4. Fill with cooling water until it overflows from the bleeder plug.

## ENGINE COOLANT

### < PERIODIC MAINTENANCE >

---

5. Install air bleeder plug. A
  6. Fill radiator and reservoir tank with water and reinstall radiator cap. A  
**CAUTION:**  
**Never adhere the water to electronic equipments. (alternator etc.)**
    - **When water overflows disconnected heater hose, connect heater hose, and continue filling the water.** CO
  7. Install air duct assembly and air cleaner cases (upper and lower) assembly. Refer to [EM-26, "Exploded View"](#). C
  8. Run the engine and warm it up to normal operating temperature.
  9. Rev the engine two or three times under no-load.
  10. Stop the engine and wait until it cools down. D
  11. Drain water from the system. Refer to [CO-8, "Draining"](#).
  12. Repeat steps 1 through 11 until clear water begins to drain from radiator. E
- F
- G
- H
- I
- J
- K
- L
- M
- N
- O
- P

# RADIATOR

< PERIODIC MAINTENANCE >

## RADIATOR

### RADIATOR CAP

#### RADIATOR CAP : Inspection

INFOID:000000008380753

- Check valve seat (A) of radiator cap.
- Check if valve seat is swollen to the extent that the edge of the plunger (B) cannot be seen when watching it vertically from the top.
- Check if valve seat has no soil and damage.
- Check that there is no dirt or damage on the valve seat of radiator cap negative-pressure valve.
- Check that there are no unusualness in the opening and closing conditions of negative-pressure valve.

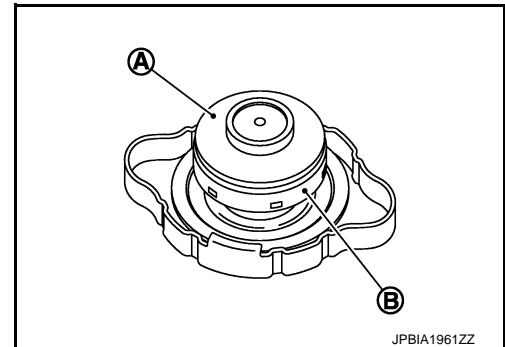

- Check radiator cap relief pressure.

**Standard and limit** : Refer to [CO-28. "Radiator"](#).

- When connecting radiator cap to the radiator cap tester (commercial service tool) and the radiator cap tester adapter (commercial service tool) (A), apply engine coolant to the cap seal surface.

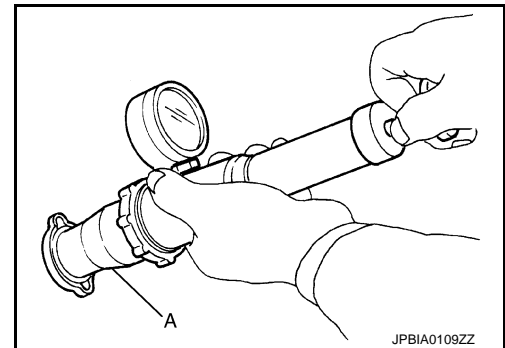

- Replace radiator cap if there is an unusualness related to the above three.

#### **CAUTION:**

**When installing radiator cap, thoroughly wipe out the radiator pipe (upper) filler neck to remove any waxy residue or foreign material.**

## RADIATOR

#### RADIATOR : Inspection

INFOID:000000008380754

Check radiator for mud or clogging. If necessary, clean radiator as follows:

#### **CAUTION:**

- **Be careful not to bend or damage radiator fins.**
  - **When radiator is cleaned without removal, remove all surrounding parts such as radiator cooling fan assembly and horns. Then tape harness and connectors to prevent water from entering.**
1. Apply water by hose to the back side of the radiator core vertically downward.
  2. Apply water again to all radiator core surfaces once per minute.
  3. Stop washing if any stains no longer flow out from radiator.
  4. Blow air into the back side of radiator core vertically downward.
    - Use compressed air lower than 490 kPa (5 kg/cm<sup>2</sup>, 71 psi) and keep distance more than 30 cm (11.81 in).
  5. Blow air again into all the radiator core surfaces once per minute until no water sprays out.

# RADIATOR

< REMOVAL AND INSTALLATION >

## REMOVAL AND INSTALLATION

### RADIATOR

Exploded View

INFOID:000000008380755

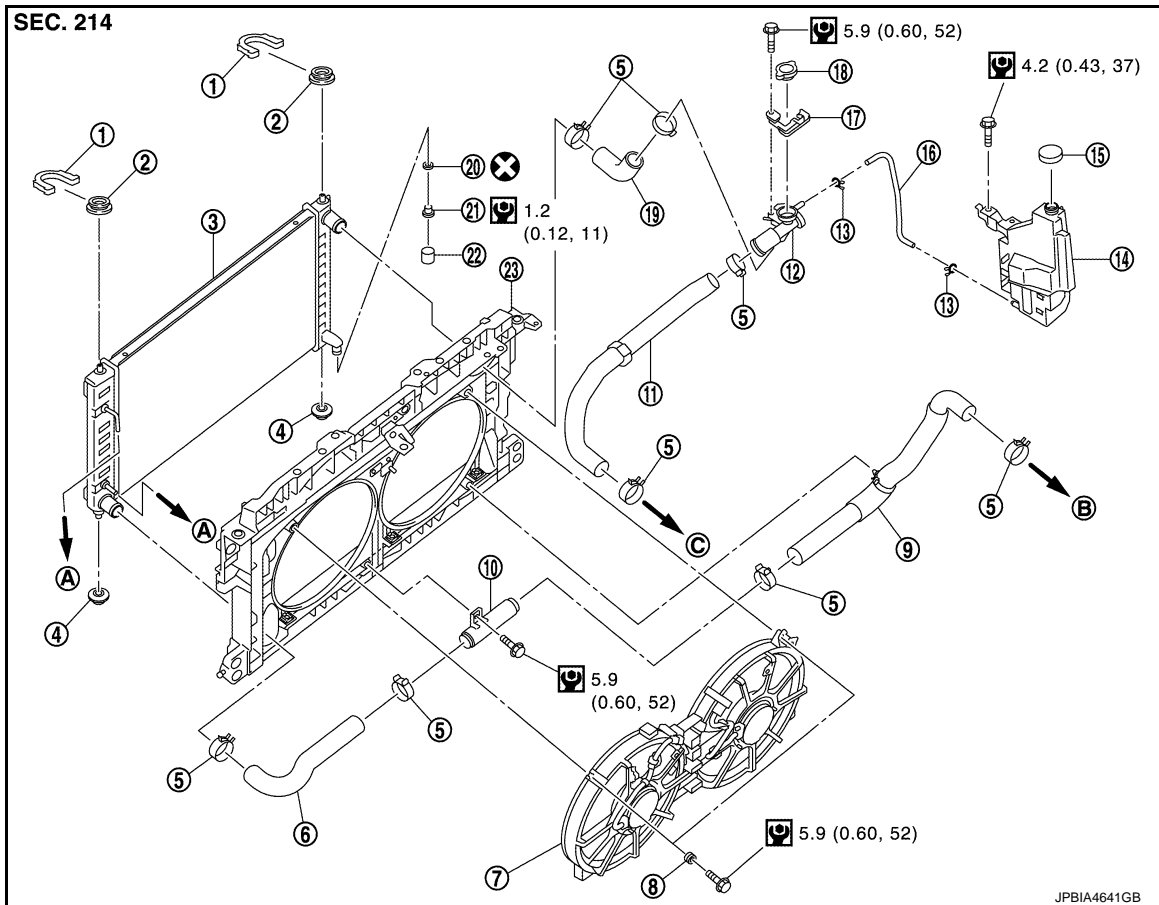

- |                            |                            |                           |
|----------------------------|----------------------------|---------------------------|
| 1. Radiator upper clip     | 2. Mounting rubber (upper) | 3. Radiator               |
| 4. Mounting rubber (lower) | 5. Clamp                   | 6. Radiator hose (lower)  |
| 7. Cooling fan assembly    | 8. Grommet                 | 9. Radiator hose (lower)  |
| 10. Radiator pipe (lower)  | 11. Radiator hose (upper)  | 12. Radiator pipe (upper) |
| 13. Clamp                  | 14. Reservoir tank         | 15. Reservoir tank cap    |
| 16. Reservoir tank hose    | 17. Radiator cap adapter   | 18. Radiator cap          |
| 19. Radiator hose (upper)  | 20. O-ring                 | 21. Drain plug            |
| 22. Water drain hose       | 23. Radiator core support  |                           |
| A To transaxle assembly    | B To water inlet           | C To water outlet         |

⊗: Always replace after every disassembly.

🔧: N·m (kg·m, in·lb)

### Removal and Installation

INFOID:000000008380756

#### REMOVAL

#### **WARNING:**

**Never remove radiator cap when engine is hot. Serious burns could occur from high-pressure engine coolant escaping from radiator. Wrap a thick cloth around the cap. Slowly turn it a quarter of a turn to release built-up pressure. Carefully remove radiator cap by turning it all the way.**

**NOTE:**

# RADIATOR

## < REMOVAL AND INSTALLATION >

When removing components such as hoses, tubes/lines, etc., cap or plug openings to prevent fluid from spilling.

1. Drain engine coolant from radiator. Refer to [CO-8, "Draining"](#).  
**CAUTION:**
  - Perform this step when the engine is cold.
  - Never spill engine coolant on drive belt.
2. Remove the following parts:
  - Air duct (inlet): Refer to [EM-26, "Exploded View"](#).
  - Front grille: Refer to [EXT-17, "Exploded View"](#).
  - Hood lock: Refer to [DLK-427, "HOOD LOCK : Removal and Installation"](#).
3. Disconnect reservoir tank hose from radiator pipe (upper).
4. Disconnect CVT fluid cooler hoses from radiator.
  - Install blind plug to avoid leakage of CVT fluid.
5. Separate low pressure flexible hose from low pressure pipe and move the separated hose. Refer to [HA-35, "LOW-PRESSURE FLEXIBLE HOSE : Removal and Installation"](#).
6. Remove radiator cap adapter and each radiator hoses (upper and lower) and radiator pipe (upper) assembly.  
**CAUTION:**  
**Be careful not to allow engine coolant to contact drive belt.**
7. Remove condenser. Refer to [HA-42, "Exploded View"](#).  
**CAUTION:**  
**Be careful not to damage condenser core.**
8. Remove each radiator upper clips (2) by pulling the tabs (A) outside to release the lock (B) and then remove each mounting rubbers (upper) (1).

C : Mounting pin

⇐ : Vehicle front

**CAUTION:**

**Never pull the tabs outside excessively to prevent it from damping.**

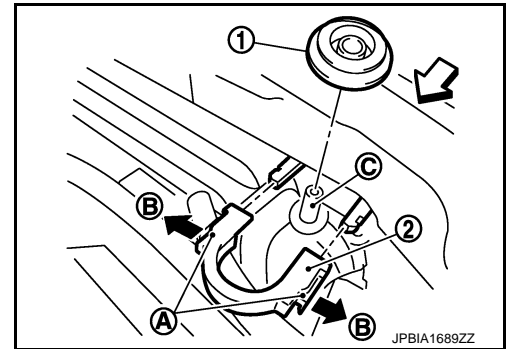

9. Lift up and remove radiator from front of radiator core support.  
**CAUTION:**  
**Be careful not to damage or scratch on radiator core.**

## INSTALLATION

Note the following, and install in the reverse order of removal.

**CAUTION:**

**Do not reuse O-ring.**

**NOTE:**

When installing radiator core support (upper), check that the upper and lower mounts of radiator and air condenser are securely inserted in each mounting hole of radiator core support (upper and lower).

**CAUTION:**

**Always use genuine bolts for cooling fan assembly mounting bolts and observe the tightening torque. (To prevent damage to radiator)**

Radiator Upper Clip

Install each radiator upper clips on radiator core connection as follows:

# RADIATOR

## < REMOVAL AND INSTALLATION >

1. Install each mounting rubbers (upper) (1) on mounting pins (A) of radiator.

↔ : Vehicle front

2. Align each radiator upper clips (2) with radiator core connection (B), then insert each radiator upper clips straight into radiator core connections until a click is heard.
3. After connecting each radiator upper clips, use the following method to check it is fully connected.
  - Visually confirm that each radiator upper clips are connected to radiator core connections.
  - Move each radiator upper clips and the radiator forward and backward to check they are securely connected.

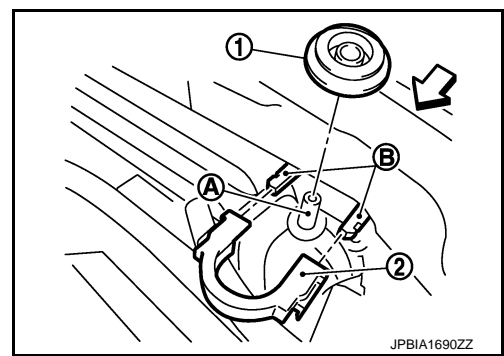

Reservoir tank

### NOTE:

Insert reservoir tank straight to the mounting position.

Radiator hose

### NOTE:

Insert the radiator hose (1) all the way to the stopper (2) or by 33 mm (1.30 in) (hose without a stopper).

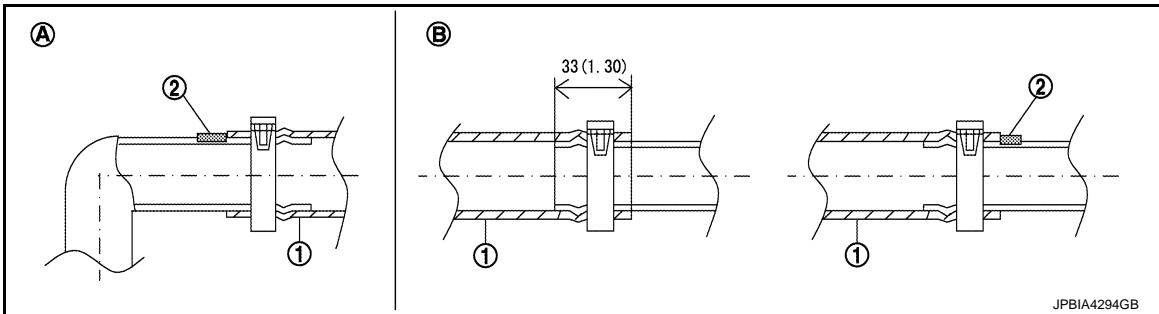

unit: mm(in)

A. Radiator side

B. Engine side

- For the orientation of the hose clamp pawl, refer to the figure.

Radiator hose	Hose end	Paint mark	Position of hose clamp*
Radiator hose (upper)	Radiator side	Right side	C
	Radiator side (radiator pipe)	—	B
	Engine side (radiator pipe)	—	C
	Engine side	Upper	D
Radiator hose (lower)	Radiator side	Upper	A
	Radiator side (radiator pipe)	—	A
	Engine side (radiator pipe)	—	A
	Engine side	Upper	E

\*:Refer to the illustrations for the specific position each hose clamp tab.

# RADIATOR

## < REMOVAL AND INSTALLATION >

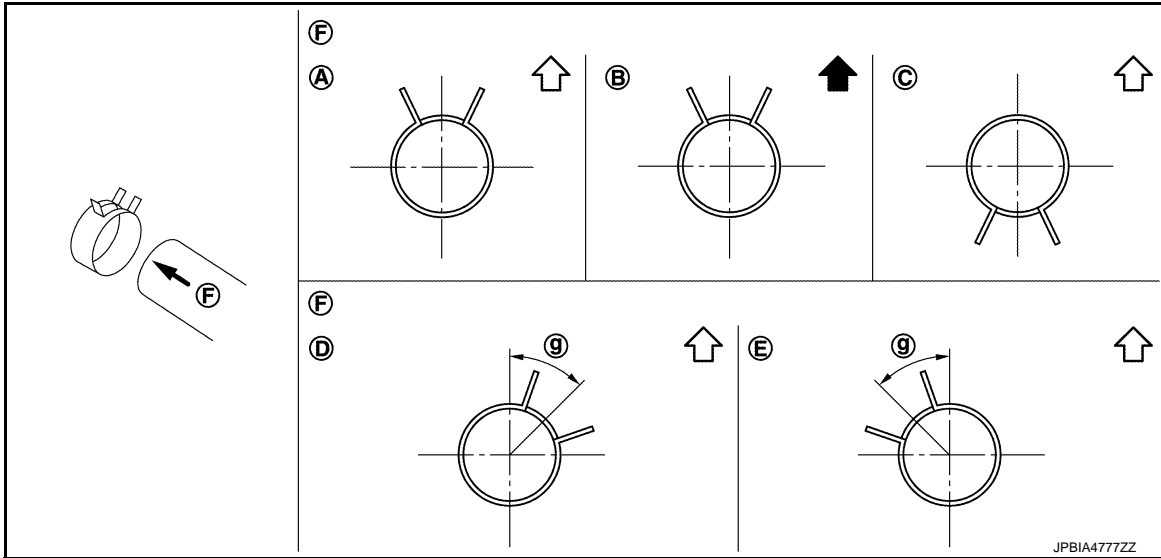

F: View F

↖ :Vehicle upper

g. :45°

← :Vehicle back side

- The angle (b) created by the hose clamp pawl and the specified line (A) must be within  $\pm 15^\circ$  as shown in the figure.

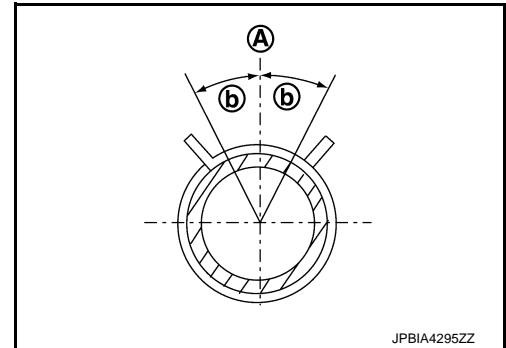

- To install hose clamps (1), check that the dimension (A) from the end of the paint mark (2) on the radiator hose to the hose clamp is within the reference value.

Dimension "A"

(-1) - (+1) mm

(-0.04) - (+0.04) in

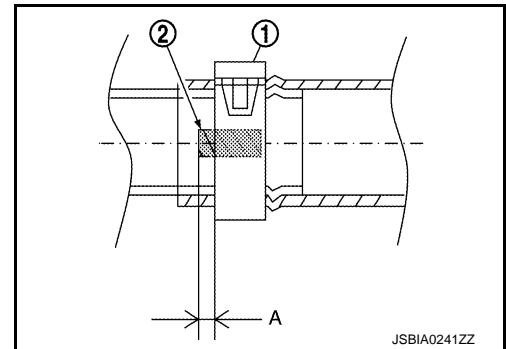

## Inspection

INFOID:000000008380757

### INSPECTION AFTER INSTALLATION

- Check for leakage of engine coolant using the radiator cap tester adapter (commercial service tool) and the radiator cap tester (commercial service tool). Refer to [CO-8. "Inspection"](#).
- Start and warm up the engine. Visually check that there is no leakage of engine coolant and CVT fluid.



# COOLING FAN

< REMOVAL AND INSTALLATION >

## COOLING FAN

### Exploded View

INFOID:000000008380758

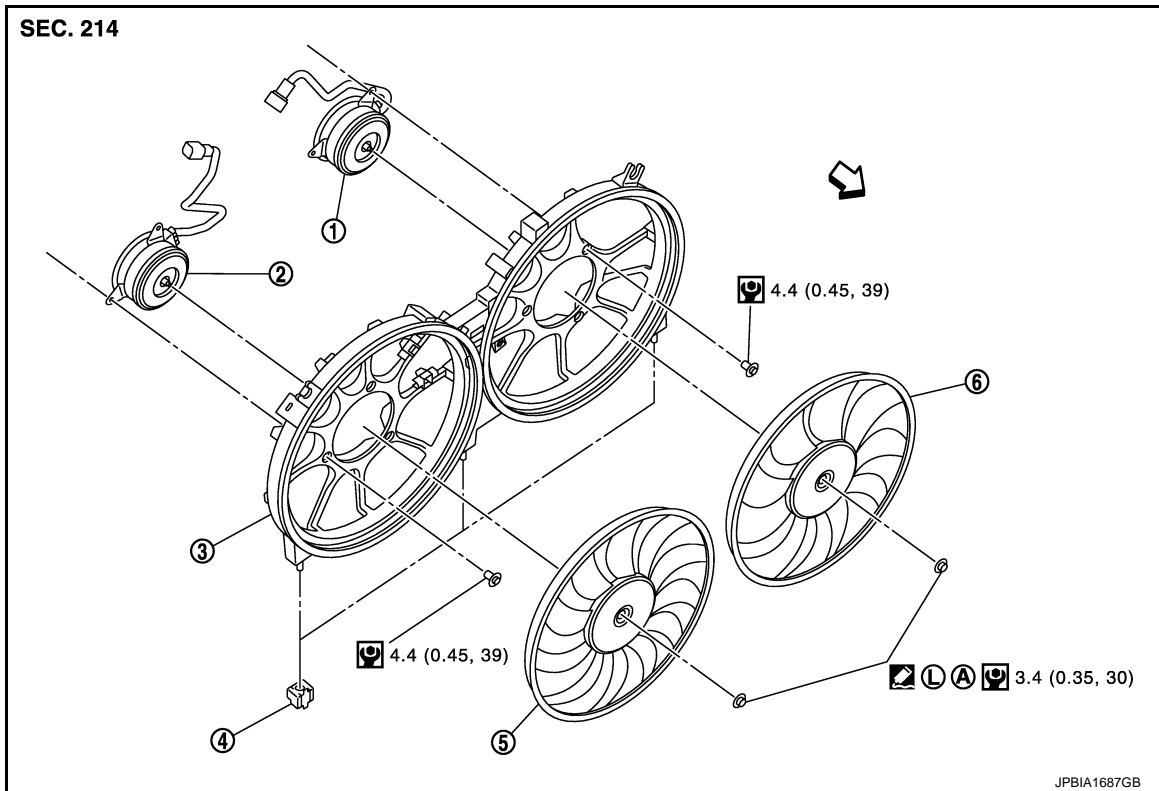

- |                    |                     |                     |
|--------------------|---------------------|---------------------|
| 1. Fan motor (LH)  | 2. Fan motor (RH)   | 3. Fan shroud       |
| 4. Mounting rubber | 5. Cooling fan (RH) | 6. Cooling fan (LH) |

A. Apply on fan motor shaft

← : Vehicle front

Ⓛ : Apply genuine high strength thread locking sealant or equivalent.

Ⓜ : N·m (kg-m, in-lb)

## Removal and Installation

INFOID:000000008380759

### REMOVAL

- Remove the following parts.
  - Engine under cover
  - Air duct (inlet): Refer to [EM-26, "Exploded View"](#).
  - Oil level gauge: Refer to [EM-93, "Exploded View"](#).
  - Battery and battery tray: Refer to [PG-130, "Removal and Installation"](#).
- Drain engine coolant from radiator. Refer to [CO-8, "Draining"](#).  
**CAUTION:**
  - Perform this step engine is cold.
  - Never spill engine coolant on drive belt.
- Remove radiator cap adapter and each radiator hoses (upper) and radiator pipe (upper) assembly. Refer to [CO-13, "Exploded View"](#).
- Disconnect harness connector from crash zone sensor, and move harness to aside. Refer to [SR-22, "Exploded View"](#).
- Disconnect harness connector from fan motors (RH and LH), and move harness to aside.
- Remove cooling fan assembly.

# COOLING FAN

## < REMOVAL AND INSTALLATION >

---

### **CAUTION:**

**Be careful not to damage or scratch on radiator core.**

### INSTALLATION

Note the following, and install in the reverse order of removal.

### **CAUTION:**

**Only use genuine parts for cooling fan mounting bolt and observe the specified torque (to prevent radiator from being damaged).**

### **NOTE:**

Cooling fans are controlled by ECM. For details, refer to [EC-45, "COOLING FAN CONTROL : System Description"](#).

## Disassembly and Assembly

INFOID:000000008380760

### DISASSEMBLY

1. Remove cooling fan mounting nuts, and then remove the cooling fans (RH and LH).
2. Remove fan motors (RH and LH).

### ASSEMBLY

Note the following, and assemble in the reverse order of disassembly.

### **CAUTION:**

**RH and LH cooling fans are different. Be careful not to misassemble them.**

- Install each fan in the following position.

**Right side : 11 blades**

**Left side : 9 blades**

- Secure the harness tightly to the fan shroud to prevent the fan rotation area from being loose.

## Inspection

INFOID:000000008380761

### INSPECTION AFTER DISASSEMBLY

#### Cooling Fan

Inspect cooling fan for crack or unusual bend.

- If anything is found, replace cooling fan.

# WATER PUMP

< REMOVAL AND INSTALLATION >

## WATER PUMP

### Exploded View

INFOID:000000008380762

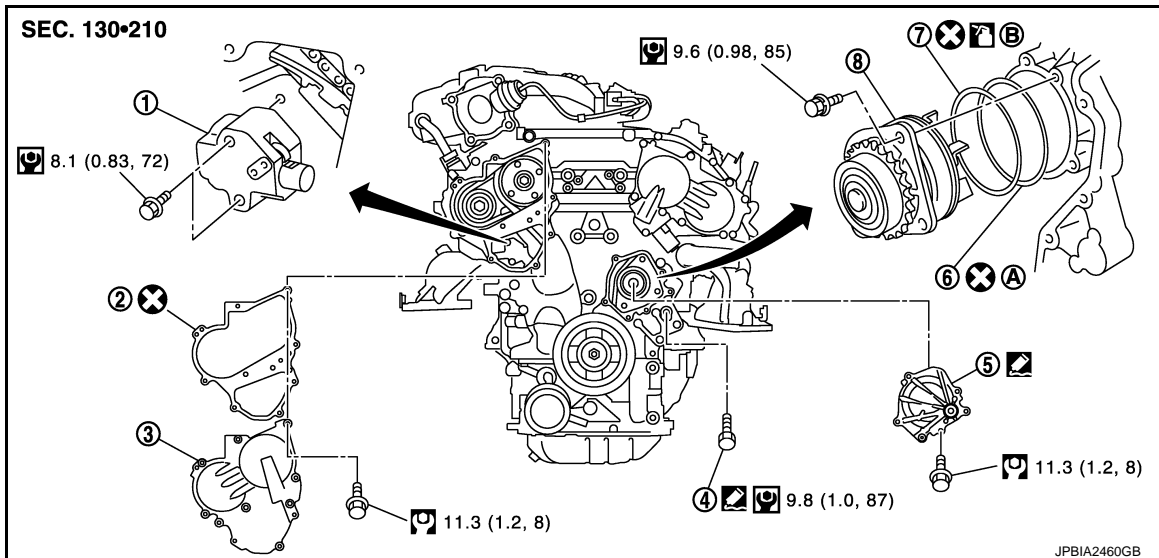

- |                                     |   |  |
|-------------------------------------|---|--|
| 1. Timing chain tensioner (primary) | 2. Valve timing control cover gasket (bank 1) | 3. Valve timing control cover (bank 1) |
| 4. Water drain plug (front)         | 5. Water pump cover                           | 6. O-ring                              |
| 7. O-ring                           | 8. Water pump                                 |  |
| A. Apply engine coolant             | B. Identify with white mark                   |  |

⊗: Always replace after every disassembly.

Ⓜ: N·m (kg-m, ft-lb)

Ⓜ: N·m (kg-m, in-lb)

Ⓛ: Should be lubricated with oil.

Ⓛ: Sealing point

### Removal and Installation

INFOID:000000008380763

#### CAUTION:

- When removing water pump assembly, be careful not to get engine coolant on drive belt.
- Water pump cannot be disassembled and should be replaced as a unit.
- After installing water pump, connect hose and clamp securely, then check for leakage using the radiator cap tester (commercial service tool) and the radiator cap tester adapter (commercial service tool).

#### REMOVAL

1. Remove the following parts.
  - Cowl top extension.
  - Engine under cover
  - Front road wheel and tire
  - Splash guard (RH): Refer to [EXT-22, "Exploded View"](#).
2. Drain engine coolant from radiator. Refer to [CO-8, "Draining"](#).  
**CAUTION:**
  - Perform this step when the engine is cold.
  - Never spill engine coolant on drive belt.
3. Remove drive belt. Refer to [EM-25, "Removal and Installation"](#).
4. Remove idler pulleys and harness bracket. Refer to [EM-25, "Removal and Installation"](#).

# WATER PUMP

## < REMOVAL AND INSTALLATION >

5. Remove torque rod (upper). Refer to [EM-56. "Removal and Installation"](#).
6. Remove water drain plug (front) on water pump side of cylinder block to drain engine coolant from engine inside.
7. Remove valve timing control cover (bank 1) and water pump cover from front timing chain case.
  - Use the seal cutter [SST: KV10111100 (J-37228)] to cut liquid gasket for removal.

8. Remove timing chain tensioner (primary) (1) as follows:

- a. Remove lower mounting bolt (A).

**CAUTION:**

Be careful not to drop mounting bolt inside timing chain case.

- b. Loosen upper mounting bolt (B) slowly, and then turn chain tensioner (primary) on the mounting bolt so that plunger (C) is fully expanded.

**NOTE:**

Even if plunger is fully expanded, it is not dropped from the body of timing chain tensioner (primary).

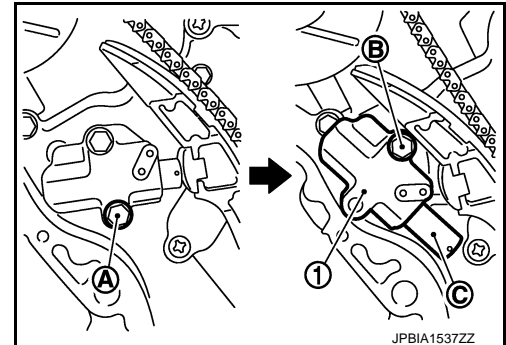

- c. Remove timing chain tensioner (primary). Refer to [EM-67. "Removal and Installation"](#).

- d. Turn crankshaft pulley clockwise so that timing chain on the timing chain tensioner (primary) side is loose.

1 : Crankshaft pulley

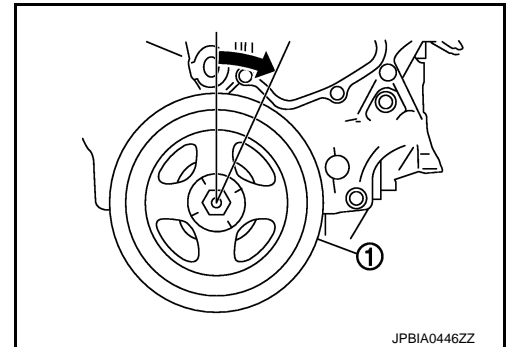

9. Remove water pump as follows:

**NOTE:**

The use of the following item simplifies the procedure.

- Thin plastic sheet cut as shown in the figure.

a :60 mm (2.36 in)

b :140 mm (5.51 in)

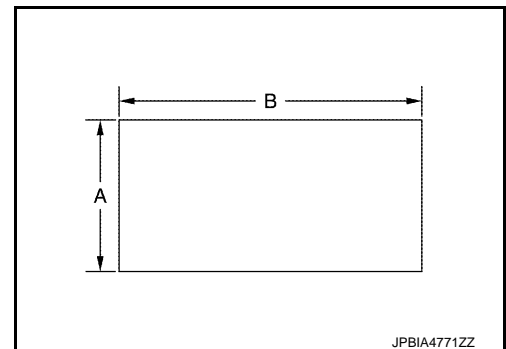

- a. Remove three water pump mounting bolts.

- b. Turn the crankshaft pulley counterclockwise to slack the water pump side timing chain for allowance.

- With the timing chain around water pump sprocket held with fingers, turn crank pulley counterclockwise to the position where the timing chain cannot be pulled in cylinder head direction.

# WATER PUMP

## < REMOVAL AND INSTALLATION >

- c. Insert sheet (A) between timing chain and water pump sprocket (1) of water pump housing.

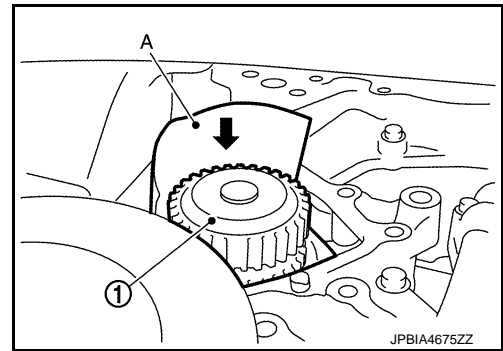

- d. Screw bolts (B) of size M8 x 1.25 (threads length: approx. 50 mm) into the upper and lower bolt holes used for mounting water pump and tighten the bolts alternately by half turn all the way to pull out water pump (1).

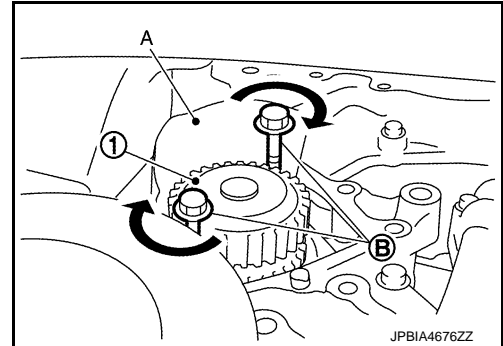

A :Sheet

- Pull out water pump straight to protect the mounting part from damage caused by vane.
- Do not allow sprocket to interfere with timing chain.

10. Remove M8 bolt and two O-rings from water pump.

## INSTALLATION

### CAUTION:

**Do not reuse O-rings.**

1. Install new O-rings to water pump.

### CAUTION:

**Do not reuse O-rings.**

- Clean mounting grooves of O-ring to remove foreign matter.
- Install O-ring with a white identification mark to the engine front side (sprocket side) and O-ring with no identification mark to the engine rear side (vane side).

### CAUTION:

**Each O-ring is made of different material. Always install appropriate O-ring to the correct position.**

2. Install water pump.

- a. Insert water pump by widening timing chain (1) with sheet (A) so as not to allow O-ring to interfere with timing chain and the corner of cylinder block.

- Apply engine oil around the O-ring with a white identification mark.
- Apply LLC around the O-ring with no identification mark.
- Insert water pump direct to cylinder block.
- Do not allow O-ring to be displaced.
- Press into water pump by tightening the mounting bolts alternately and evenly.
- Check timing chain and water pump sprocket for proper engagement.

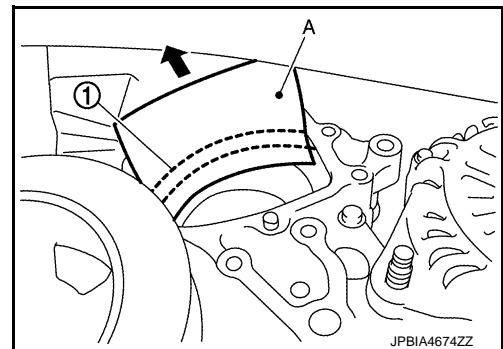

3. Install timing chain tensioner (primary) as follows:

- a. Completely remove dust and foreign matter from the back of chain tensioner (primary) and the mounting surface on the rear timing chain case.

# WATER PUMP

## < REMOVAL AND INSTALLATION >

- b. Turn crank pulley (1) clockwise (direction shown by arrow) to loosen timing chain on the chain tensioner (primary) side.

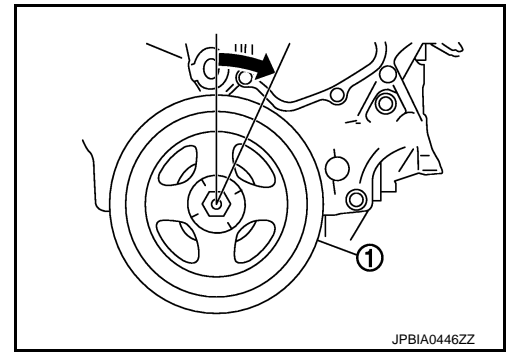

- c. Lift self-locking pawl (A) to obtain allowance between the pawl and the ratchet of plunger (D).  
 d. Press plunger into tensioner body.  
 e. Fix self-locking pawl at the tip of ratchet and maintain plunger in its maximum compression.  
 f. Insert stopper pin (E) into the tensioner body hole (B) to fix lever (C).  
 • Plunger becomes fixed at this step because of the interlock between the lever and self-locking pawl.

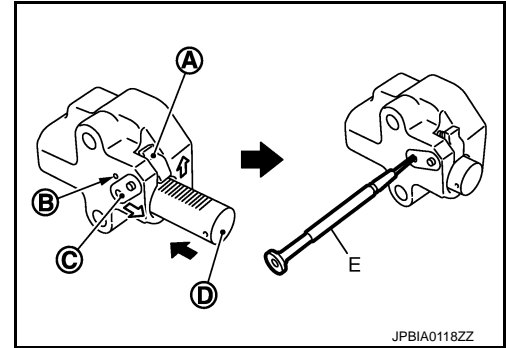

**NOTE:**

The figure shows a work example of using a precision screw driver of axis diameter  $\phi 1.2$  mm as a stopper pin.

- g. Install chain tensioner (primary).  
 • Completely remove dust and foreign matter from the back of chain tensioner (primary) and the mounting surface before installing chain tensioner.  
 h. After the installation, remove stopper pin (A) to release plunger.  
 i. Check again that water pump sprocket and timing chain are engaged.

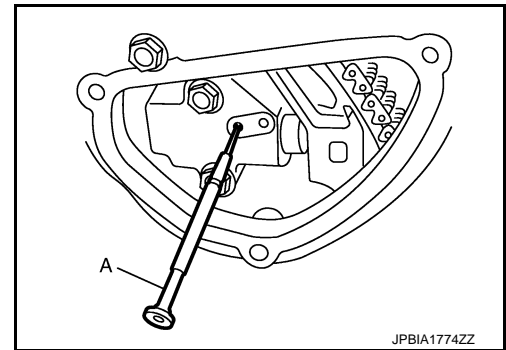

4. Install cam sprocket cover (Bank 1). Refer to [EM-67. "Removal and Installation"](#).  
 5. Install water pump cover as per the following instructions:  
 a. Remove old liquid gasket on the back of cover, the front timing chain case mounting surface, mounting bolt threads, and the bolt hole, by using a scraper.  
 • Clean the mounting surface with white gasoline.  
 b. Apply liquid gasket evenly without any gap and overlap. Refer to [CO-5. "Liquid Gasket"](#)

- 1 :Water pump cover  
 a :  $\phi 2.3 - 3.3$  mm

- c. Tighten mounting bolts.  
 6. Install water drain plug (front).  
 • Apply liquid gasket to the threads and tighten the screw.  
 7. Install the following items in the reverse order of removal.

**NOTE:**

When starting the engine or immediately after an engine start after the removal/installation procedure of chain tensioner (primary), slapping sound may be heard. This is

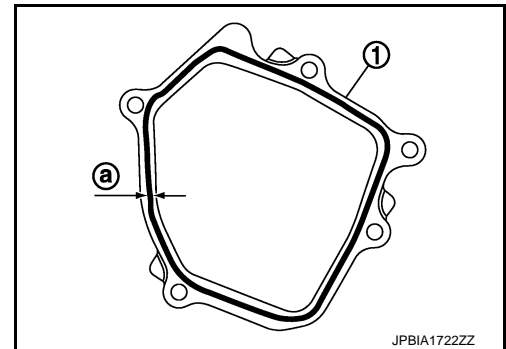

# WATER PUMP

## < REMOVAL AND INSTALLATION >

not a malfunction. The slapping sound is generated due to decrease in oil pressure of the chain tensioner (primary) and eliminated as oil pressure increases.

### Inspection

INFOID:000000008380764

#### INSPECTION AFTER REMOVAL

- Check for badly rusted or corroded water pump body assembly.
- Check for rough operation due to excessive end play.
- If anything is found, replace water pump.

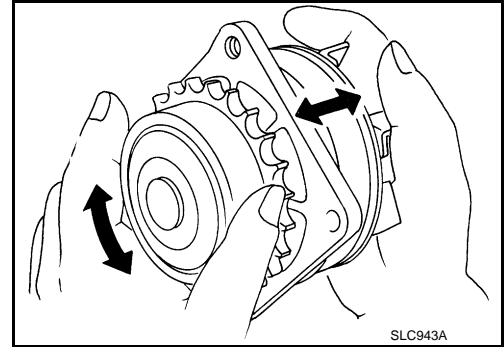

#### INSPECTION AFTER INSTALLATION

- Check for leakage of engine coolant using the radiator cap tester adapter (commercial service tool) and the radiator cap tester (commercial service tool). Refer to [CO-8, "Inspection"](#).
- Start and warm up the engine. Visually check that there is no leakage of engine coolant.

A  
CO  
C  
D  
E  
F  
G  
H  
I  
J  
K  
L  
M  
N  
O  
P

# WATER INLET AND THERMOSTAT ASSEMBLY

< REMOVAL AND INSTALLATION >

## WATER INLET AND THERMOSTAT ASSEMBLY

Exploded View

INFOID:000000008380765

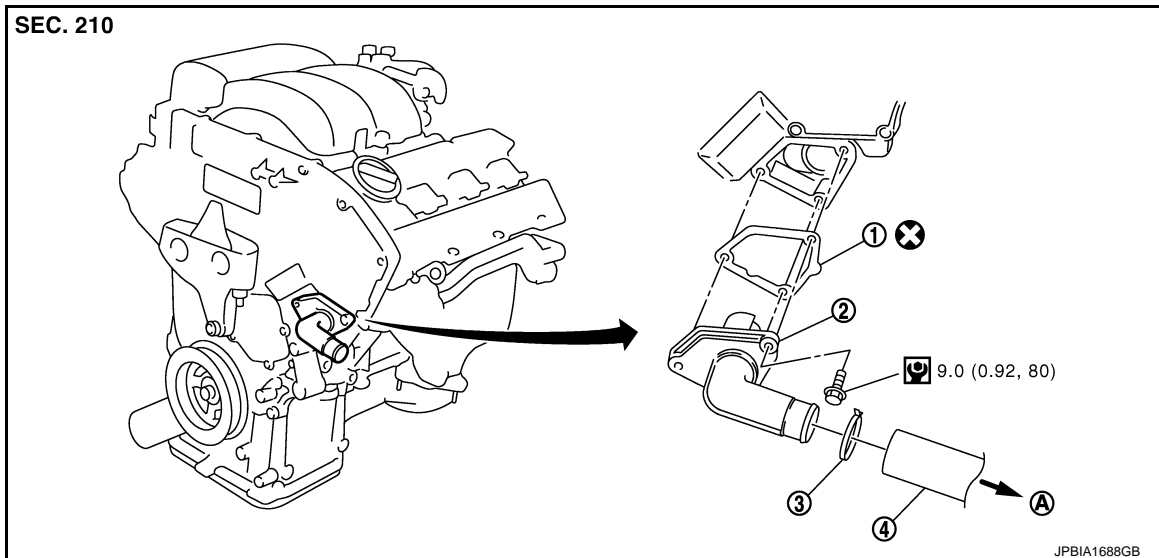

1. Gasket
2. Water inlet and thermostat assembly
3. Clamp
4. Radiator hose (lower)
- A. To radiator

⊗ : Always replace after every disassembly.

Ⓜ : N·m (kg·m, in·lb)

## Removal and Installation

INFOID:000000008380766

### REMOVAL

1. Drain engine coolant from radiator drain plug at the bottom of radiator, and from water drain plug at the front of cylinder block. Refer to [CO-8. "Draining"](#) and [EM-63. "Setting"](#).  
**CAUTION:**
  - Perform this step when the engine is cold.
  - Never spill engine coolant on drive belt.
2. Remove reservoir tank of radiator, and move it aside. Refer to [CO-13. "Exploded View"](#).
3. Remove camshaft sprocket cover (bank 2). Refer to [EM-66. "Exploded View"](#).
4. Disconnect radiator hose (lower) from water inlet and thermostat assembly.
5. Remove water inlet and thermostat assembly (1) and gasket.

A : Never loosen these screw

**CAUTION:**  
Never disassemble water inlet and thermostat assembly.  
Replace them as a unit, if necessary.

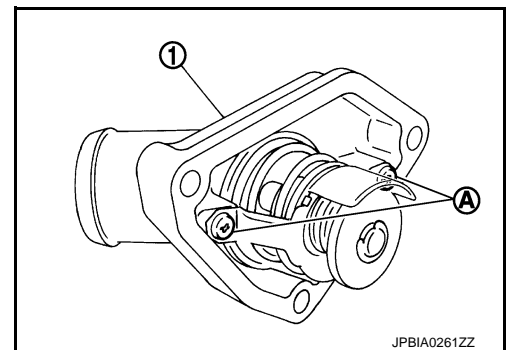

### INSTALLATION

Note the following, and install in the reverse order of removal.

- Be careful not to spill engine coolant over engine room. Use rag to absorb engine coolant.



# WATER INLET AND THERMOSTAT ASSEMBLY

< REMOVAL AND INSTALLATION >

## Inspection

INFOID:000000008380767

### INSPECTION AFTER REMOVAL

1. Check valve seating condition at ordinary room temperatures. It should seat tightly.
2. Check valve operation.

**Thermostat (Standard)** : Refer to [CO-28, "Thermostat"](#).

- If the malfunctioning condition, when valve seating at ordinary room temperature, or measured values are out of the standard, replace water inlet and thermostat assembly.

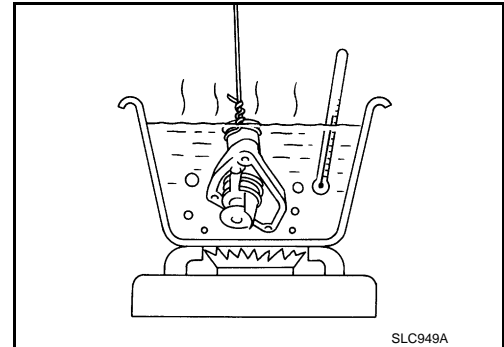

### INSPECTION AFTER INSTALLATION

- Check for leakage of engine coolant using the radiator cap tester adapter (commercial service tool) and the radiator cap tester (commercial service tool). Refer to [CO-8, "Inspection"](#).
- Start and warm up the engine. Visually check that there is no leakage of engine coolant.

A  
CO  
C  
D  
E  
F  
G  
H  
I  
J  
K  
L  
M  
N  
O  
P

# WATER OUTLET AND WATER PIPING

< REMOVAL AND INSTALLATION >

## WATER OUTLET AND WATER PIPING

Exploded View

INFOID:000000008380768

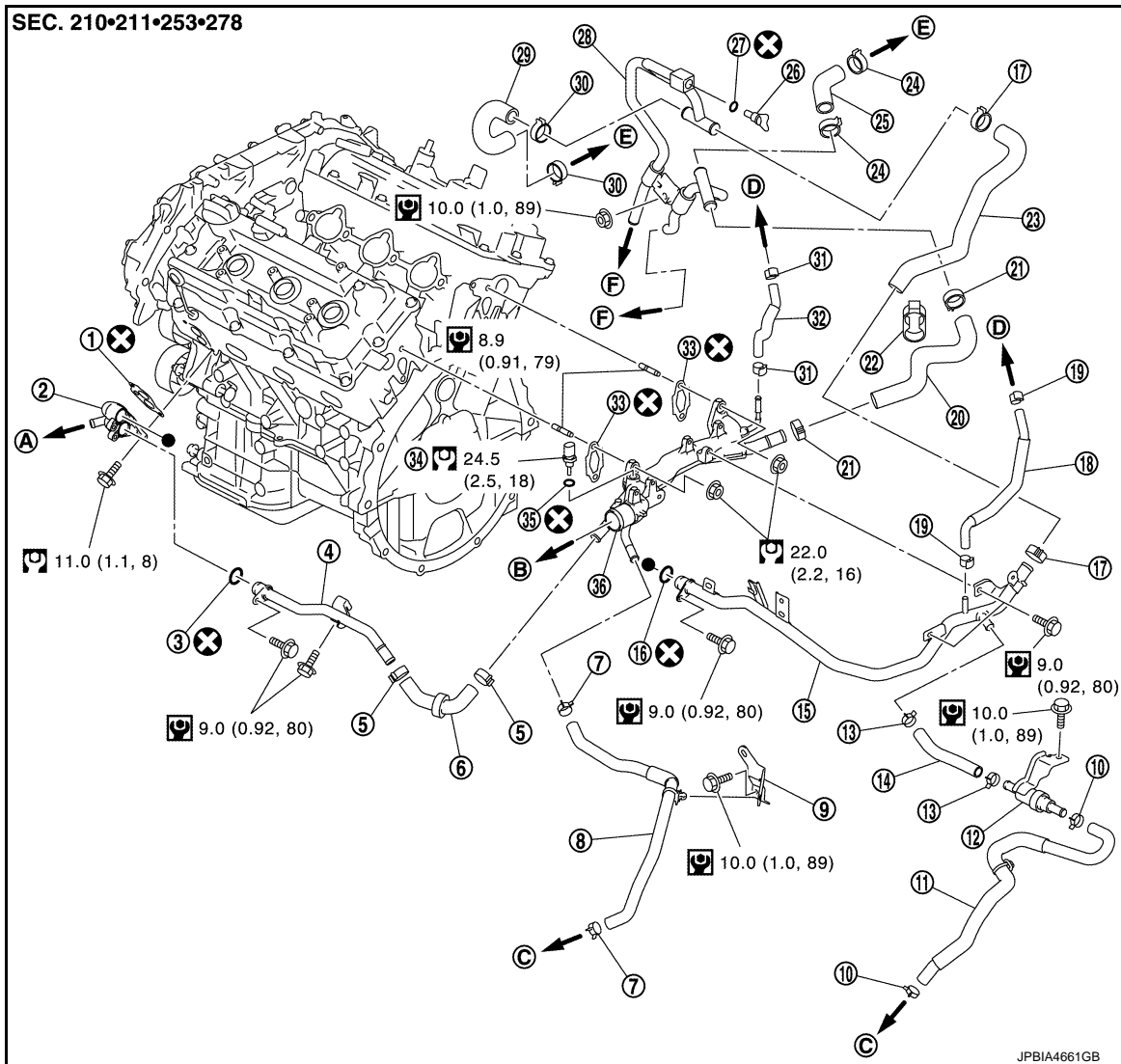



- |  |                      |                        |
|--|----------------------|------------------------|
| 1. Gasket                                | 2. Water connector   | 3. O-ring              |
| 4. Water bypass pipe                     | 5. Clamp             | 6. Water hose          |
| 7. Clamp                                 | 8. Water hose        | 9. Bracket             |
| 10. Clamp                                | 11. Water hose       | 12. Heater thermostat  |
| 13. Clamp                                | 14. Water hose       | 15. Heater pipe        |
| 16. O-ring                               | 17. Clamp            | 18. Water hose         |
| 19. Clamp                                | 20. Heater hose      | 21. Clamp              |
| 22. Clip                                 | 23. Heater hose      | 24. Clamp              |
| 25. Heater hose                          | 26. Air bleeder plug | 27. O-ring             |
| 28. Heater pipe                          | 29. Heater hose      | 30. Clamp              |
| 31. Clamp                                | 32. Water hose       | 33. Gasket             |
| 34. Engine coolant temperature sensor    | 35. Gasket           | 36. Water outlet       |
| 37. Bracket                              |                      |                        |
| A. To oil cooler                         | B. To radiator       | C. To CVT fluid warmer |
| D. To electric throttle control actuator | E. To heater core    | F. To rear heater      |

⊗: Always replace after every disassembly.

# WATER OUTLET AND WATER PIPING

## < REMOVAL AND INSTALLATION >

 : N·m (kg·m, ft·lb)

 : N·m (kg·m, in·lb)

A

## Removal and Installation

INFOID:000000008380769

CO

### REMOVAL

1. Remove air duct (inlet), air cleaner cases (upper and lower) with mass air flow sensor and air duct assembly. Refer to [EM-26, "Exploded View"](#). C
2. Remove engine cover. Refer to [EM-24, "Exploded View"](#).
3. Drain engine coolant from radiator drain plug at the bottom of radiator, and from water drain plug at the front of cylinder block. Refer to [CO-8, "Draining"](#) and [EM-63, "Setting"](#). D  
**CAUTION:**
  - Perform this step when the engine is cold.
  - Never spill engine coolant on drive belt.
4. Remove battery and battery tray. Refer to [PG-130, "Removal and Installation"](#).
5. Remove CVT fluid charging pipe and CVT fluid level gauge. Refer to [EM-38, "Exploded View"](#). F
6. Remove oil level gauge. Refer to [EM-38, "Exploded View"](#).
7. Move CVT control cable aside. Refer to [TM-149, "Exploded View"](#).
8. Remove vacuum tube (front) mounting bolt from water outlet. Refer to [CO-26, "Exploded View"](#). G
9. Remove radiator hose (upper) from water outlet.
10. Remove water hoses and heater hoses.
11. Remove harness bracket. H
12. Disconnect harness connectors, and move harness to aside.
13. Remove engine coolant temperature sensor if necessary. I  
**CAUTION:**
  - Be careful not to damage engine coolant temperature sensor.
14. Remove reservoir tank. Refer to [CO-13, "Exploded View"](#). J
15. Remove alternator bracket. Refer to [CHG-26, "Exploded View"](#).
16. Remove water outlet, heater pipe, water bypass pipe and water connector.

### INSTALLATION

#### **CAUTION:**

#### **Do not reuse O-rings.**

Note the following, and install in the reverse order of removal.

- Securely insert each hose, and install clamp at a position where it does not interfere with the pipe bulge.
- When inserting water bypass pipe and heater pipe into water connector, apply neutral detergent to O-ring.

### Inspection

INFOID:000000008380770

M

### INSPECTION AFTER INSTALLATION

- Check for leakage of engine coolant using the radiator cap tester adapter (commercial service tool) and the radiator cap tester (commercial service tool). Refer to [CO-8, "Inspection"](#). N
- Start and warm up the engine. Visually check that there is no leakage of engine coolant.

O

P

## SERVICE DATA AND SPECIFICATIONS (SDS)

< SERVICE DATA AND SPECIFICATIONS (SDS)

## SERVICE DATA AND SPECIFICATIONS (SDS)

### SERVICE DATA AND SPECIFICATIONS (SDS)

#### Periodical Maintenance Specification

INFOID:000000008380771

#### ENGINE COOLANT CAPACITY (APPROXIMATE)

Unit: ℓ (US qt, Imp qt)

Engine coolant capacity (With reservoir tank at "MAX" level)	11.3 (12, 10)
Reservoir tank	0.75 (6/8, 5/8)

#### Radiator

INFOID:000000008380772

Unit: kPa (kg/cm<sup>2</sup>, psi)

Cap relief pressure	Standard	122.3 - 151.7 (1.2 - 1.5, 17.7 - 22.0)
	Limit	108 (1.1, 15.6)
Leakage test pressure		156 (1.59, 22.6)

#### Thermostat

INFOID:000000008380773

##### Standard

Valve opening temperature	80.5 - 83.5°C (177 - 182°F)
Maximum valve lift	8.6 mm/95°C (0.339 in/203°F)
Valve closing temperature	77°C (171°F)