

# SECTION **PCS**

## POWER CONTROL SYSTEM

A  
B  
C  
D  
E  
F  
G  
H  
I  
J  
K  
L  
N  
O  
P

### CONTENTS

<b>IPDM E/R</b>	Fail-safe .....	23
<b>PRECAUTION</b> .....	DTC Index .....	24
<b>PRECAUTIONS</b> .....	<b>WIRING DIAGRAM</b> .....	26
Precaution for Supplemental Restraint System (SRS) "AIR BAG" and "SEAT BELT PRE-TENSIONER" .....	<b>IPDM E/R</b> .....	26
	Wiring Diagram .....	26
<b>SYSTEM DESCRIPTION</b> .....	<b>DTC/CIRCUIT DIAGNOSIS</b> .....	29
<b>COMPONENT PARTS</b> .....	<b>U1000 CAN COMM CIRCUIT</b> .....	29
<b>IPDM E/R</b> .....	Description .....	29
IPDM E/R : Component Parts Location .....	DTC Logic .....	29
<b>SYSTEM</b> .....	Diagnosis Procedure .....	29
<b>RELAY CONTROL SYSTEM</b> .....	<b>B2098 IGNITION RELAY ON STUCK</b> .....	30
RELAY CONTROL SYSTEM : System Description .....	Description .....	30
RELAY CONTROL SYSTEM : Fail-safe .....	DTC Logic .....	30
<b>POWER CONTROL SYSTEM</b> .....	Diagnosis Procedure .....	30
POWER CONTROL SYSTEM : System Description .....	<b>B2099 IGNITION RELAY OFF STUCK</b> .....	31
<b>SIGNAL BUFFER SYSTEM</b> .....	Description .....	31
SIGNAL BUFFER SYSTEM : System Description .....	DTC Logic .....	31
<b>POWER CONSUMPTION CONTROL SYSTEM</b> .....	Diagnosis Procedure .....	31
POWER CONSUMPTION CONTROL SYSTEM : System Diagram .....	<b>POWER SUPPLY AND GROUND CIRCUIT</b> .....	32
POWER CONSUMPTION CONTROL SYSTEM : System Description .....	Diagnosis Procedure .....	32
<b>DIAGNOSIS SYSTEM (IPDM E/R)</b> .....	<b>REMOVAL AND INSTALLATION</b> .....	33
Diagnosis Description .....	<b>IPDM E/R</b> .....	33
CONSULT Function (IPDM E/R) .....	Exploded View .....	33
<b>ECU DIAGNOSIS INFORMATION</b> .....	Removal and Installation .....	33
<b>IPDM E/R</b> .....	<b>POWER DISTRIBUTION SYSTEM</b>	
Reference Value .....	<b>PRECAUTION</b> .....	34
	<b>PRECAUTIONS</b> .....	34
	Precaution for Supplemental Restraint System (SRS) "AIR BAG" and "SEAT BELT PRE-TENSIONER" .....	34
	<b>SYSTEM DESCRIPTION</b> .....	35

PCS

<b>COMPONENT PARTS</b> .....	<b>35</b>	DTC Logic .....	54
Component Parts Location .....	35	Diagnosis Procedure .....	54
<b>SYSTEM</b> .....	<b>36</b>	Component Inspection .....	55
<b>POWER DISTRIBUTION SYSTEM</b> .....	<b>36</b>	<b>B2618 BCM</b> .....	<b>56</b>
POWER DISTRIBUTION SYSTEM : System De- scription .....	36	DTC Logic .....	56
Fail-safe .....	37	Diagnosis Procedure .....	56
<b>DIAGNOSIS SYSTEM (BCM)</b> .....	<b>38</b>	<b>B261A PUSH-BUTTON IGNITION SWITCH</b> ....	<b>58</b>
<b>COMMON ITEM</b> .....	<b>38</b>	DTC Logic .....	58
COMMON ITEM : CONSULT Function (BCM - COMMON ITEM) .....	38	Diagnosis Procedure .....	58
<b>INTELLIGENT KEY</b> .....	<b>39</b>	<b>B26F1 IGNITION RELAY</b> .....	<b>60</b>
INTELLIGENT KEY : CONSULT Function (BCM - INTELLIGENT KEY) .....	40	DTC Logic .....	60
<b>ECU DIAGNOSIS INFORMATION</b> .....	<b>44</b>	Diagnosis Procedure .....	60
<b>BCM</b> .....	<b>44</b>	<b>B26F2 IGNITION RELAY</b> .....	<b>61</b>
List of ECU Reference .....	44	DTC Logic .....	61
<b>WIRING DIAGRAM</b> .....	<b>45</b>	Diagnosis Procedure .....	61
<b>POWER DISTRIBUTION SYSTEM</b> .....	<b>45</b>	<b>B26F6 BCM</b> .....	<b>63</b>
Wiring Diagram .....	45	DTC Logic .....	63
<b>BASIC INSPECTION</b> .....	<b>47</b>	Diagnosis Procedure .....	63
<b>DIAGNOSIS AND REPAIR WORK FLOW</b> .....	<b>47</b>	<b>PUSH-BUTTON IGNITION SWITCH</b> .....	<b>64</b>
Work Flow .....	47	Component Function Check .....	64
<b>DTC/CIRCUIT DIAGNOSIS</b> .....	<b>50</b>	Diagnosis Procedure .....	64
<b>B2614 ACC RELAY CIRCUIT</b> .....	<b>50</b>	Component Inspection .....	65
DTC Logic .....	50	<b>PUSH-BUTTON IGNITION SWITCH POSI- TION INDICATOR</b> .....	<b>67</b>
Diagnosis Procedure .....	50	Description .....	67
Component Inspection .....	51	Component Function Check .....	67
<b>B2615 BLOWER RELAY CIRCUIT</b> .....	<b>52</b>	Diagnosis Procedure .....	67
DTC Logic .....	52	<b>SYMPTOM DIAGNOSIS</b> .....	<b>69</b>
Diagnosis Procedure .....	52	<b>PUSH-BUTTON IGNITION SWITCH DOES NOT OPERATE</b> .....	<b>69</b>
Component Inspection .....	53	Description .....	69
<b>B2616 IGNITION RELAY CIRCUIT</b> .....	<b>54</b>	Diagnosis Procedure .....	69
		<b>PUSH-BUTTON IGNITION SWITCH POSI- TION INDICATOR DOES NOT ILLUMINATE</b> ...	<b>70</b>
		Description .....	70
		Diagnosis Procedure .....	70

## PRECAUTION

### PRECAUTIONS

#### Precaution for Supplemental Restraint System (SRS) "AIR BAG" and "SEAT BELT PRE-TENSIONER"

INFOID:000000008380866

The Supplemental Restraint System such as "AIR BAG" and "SEAT BELT PRE-TENSIONER", used along with a front seat belt, helps to reduce the risk or severity of injury to the driver and front passenger for certain types of collision. This system includes seat belt switch inputs and dual stage front air bag modules. The SRS system uses the seat belt switches to determine the front air bag deployment, and may only deploy one front air bag, depending on the severity of a collision and whether the front occupants are belted or unbelted. Information necessary to service the system safely is included in the "SRS AIR BAG" and "SEAT BELT" of this Service Manual.

**WARNING:**

Always observe the following items for preventing accidental activation.

- To avoid rendering the SRS inoperative, which could increase the risk of personal injury or death in the event of a collision that would result in air bag inflation, all maintenance must be performed by an authorized NISSAN/INFINITI dealer.
- Improper maintenance, including incorrect removal and installation of the SRS, can lead to personal injury caused by unintentional activation of the system. For removal of Spiral Cable and Air Bag Module, see "SRS AIR BAG".
- Never use electrical test equipment on any circuit related to the SRS unless instructed to in this Service Manual. SRS wiring harnesses can be identified by yellow and/or orange harnesses or harness connectors.

#### PRECAUTIONS WHEN USING POWER TOOLS (AIR OR ELECTRIC) AND HAMMERS

**WARNING:**

Always observe the following items for preventing accidental activation.

- When working near the Air Bag Diagnosis Sensor Unit or other Air Bag System sensors with the ignition ON or engine running, never use air or electric power tools or strike near the sensor(s) with a hammer. Heavy vibration could activate the sensor(s) and deploy the air bag(s), possibly causing serious injury.
- When using air or electric power tools or hammers, always switch the ignition OFF, disconnect the battery, and wait at least 3 minutes before performing any service.

A  
B  
C  
D  
E  
F  
G  
H  
I  
J  
K  
L

PCS

N  
O  
P

< SYSTEM DESCRIPTION >

## SYSTEM DESCRIPTION

### COMPONENT PARTS

IPDM E/R

IPDM E/R : Component Parts Location

INFOID:000000008380867

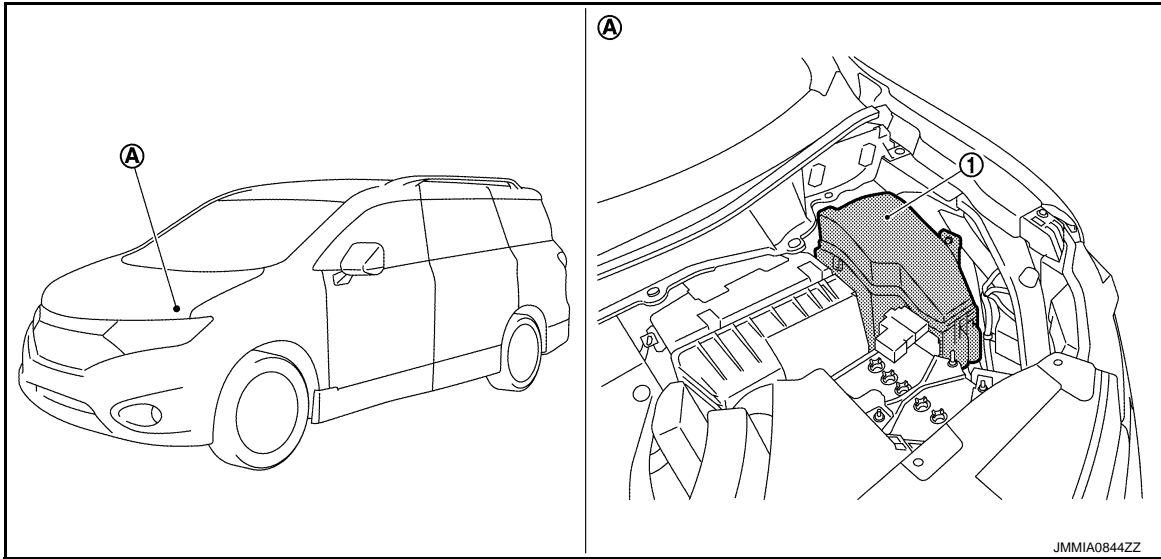

- 1. IPDM E/R
- A. Engine room (LH)

# SYSTEM

[IPDM E/R]

< SYSTEM DESCRIPTION >

## SYSTEM

### RELAY CONTROL SYSTEM

### RELAY CONTROL SYSTEM : System Description

INFOID:000000008380868

### SYSTEM DIAGRAM

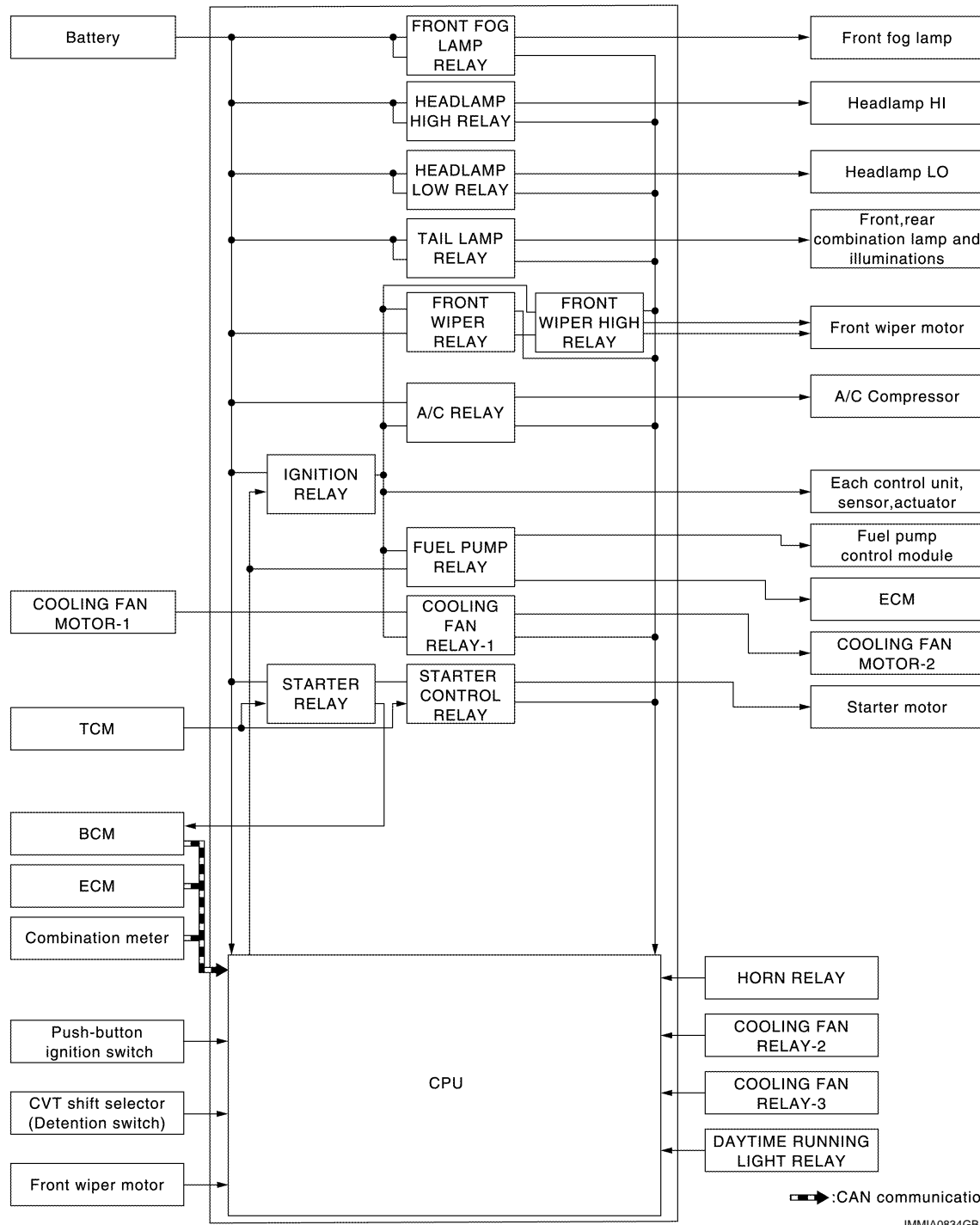

### DESCRIPTION

IPDM E/R activates the internal control circuit to perform the relay ON-OFF control according to the input signals from various sensors and the request signals received from control units via CAN communication.

### CAUTION:

To prevent damage to the parts, IPDM E/R integrated relays cannot be removed.

# SYSTEM

< SYSTEM DESCRIPTION >

[IPDM E/R]

Control relay	Input/output	Transmit unit	Control part	Reference page
Headlamp low relay	Low beam request signal	BCM (CAN)	Headlamp (LO)	<ul style="list-style-type: none"> <li>• <a href="#">EXL-11</a> (Xenon type)</li> <li>• <a href="#">EXL-111</a> (Halogen type)</li> </ul>
Headlamp high relay	High beam request signal	BCM (CAN)	Headlamp (HI)	
Front fog lamp relay	Front fog light request signal	BCM (CAN)	Front fog lamp	<ul style="list-style-type: none"> <li>• <a href="#">EXL-25</a> (Xenon type)</li> <li>• <a href="#">EXL-125</a> (Halogen type)</li> </ul>
Tail lamp relay	Position light request signal	BCM (CAN)	<ul style="list-style-type: none"> <li>• Parking lamp</li> <li>• license plate lamp</li> <li>• Tail lamp</li> <li>• Side marker lamp</li> </ul>	<ul style="list-style-type: none"> <li>• <a href="#">EXL-22</a> (Xenon type)</li> <li>• <a href="#">EXL-122</a> (Halogen type)</li> </ul>
			Illumination	<a href="#">INL-15</a>
<ul style="list-style-type: none"> <li>• Front wiper relay</li> <li>• Front wiper high relay</li> </ul>	Front wiper request signal	BCM (CAN)	Front wiper motor	<a href="#">WW-7</a>
	Front wiper stop position signal	Front wiper motor		
Horn relay	<ul style="list-style-type: none"> <li>• Theft warning horn request signal</li> <li>• Horn reminder signal</li> </ul>	BCM (CAN)	<ul style="list-style-type: none"> <li>• Horn (high)</li> <li>• Horn (low)</li> </ul>	<a href="#">SEC-20</a>
<ul style="list-style-type: none"> <li>• Starter relay*</li> <li>• Starter control relay</li> </ul>	Starter control relay signal	BCM (CAN)	Starter motor	<a href="#">SEC-5</a>
	Starter relay control signal	TCM		
	Starter motor relay cut off signal	ECM (CAN)		<a href="#">EC-56</a>
A/C relay	A/C compressor request signal	ECM (CAN)	A/C compressor (magnet clutch)	<ul style="list-style-type: none"> <li>• <a href="#">HAC-19</a> (Automatic air conditioning)</li> <li>• <a href="#">HAC-154</a> (Manual air conditioning)</li> </ul>
<ul style="list-style-type: none"> <li>• Cooling fan relay-1</li> <li>• Cooling fan relay-2</li> <li>• Cooling fan relay-3</li> </ul>	Cooling fan speed request signal	ECM (CAN)	<ul style="list-style-type: none"> <li>• Cooling fan motor-1</li> <li>• Cooling fan motor-2</li> </ul>	<a href="#">EC-45</a>
Ignition relay	Ignition switch ON signal	BCM (CAN)	Each control unit, sensor, actuator and relay (ignition power supply)	<a href="#">PCS-30</a>
	Vehicle speed signal	Combination meter (CAN)		
	Push-button ignition switch signal	Push-button ignition switch		
Daytime running light relay	Daytime running light request signal	BCM (CAN)	Headlamp (HI)	<ul style="list-style-type: none"> <li>• <a href="#">EXL-19</a> (Xenon type)</li> <li>• <a href="#">EXL-119</a> (Halogen type)</li> </ul>

\*: BCM controls the starter relay.

## RELAY CONTROL SYSTEM : Fail-safe

INFOID:000000008838564

### CAN COMMUNICATION CONTROL

When CAN communication with ECM and BCM is impossible, IPDM E/R performs fail-safe control. After CAN communication recovers normally, it also returns to normal control.

If No CAN Communication Is Available With ECM

# SYSTEM

< SYSTEM DESCRIPTION >

[IPDM E/R]

Control part	Fail-safe operation
Cooling fan	<ul style="list-style-type: none"> <li>• Turns ON the cooling fan relay-2 and the cooling fan relay-3 when the ignition switch is turned ON (Cooling fan operates at HI)</li> <li>• Turns OFF the cooling fan relay-1, the cooling fan relay-2 and the cooling fan relay-3 when the ignition switch is turned OFF (Cooling fan does not operate)</li> </ul>
A/C compressor	A/C relay OFF
Alternator	Outputs the power generation command signal (PWM signal) 0%

If No CAN Communication Is Available With BCM

Control part	Fail-safe operation
Headlamp	<ul style="list-style-type: none"> <li>• Turns ON the headlamp low relay when the ignition switch is turned ON</li> <li>• Turns OFF the headlamp low relay when the ignition switch is turned OFF</li> <li>• Headlamp high relay OFF</li> </ul>
<ul style="list-style-type: none"> <li>• Parking lamp</li> <li>• License plate lamp</li> <li>• Illumination</li> <li>• Tail lamp</li> <li>• Side marker lamp</li> </ul>	<ul style="list-style-type: none"> <li>• Turns ON the tail lamp relay when the ignition switch is turned ON</li> <li>• Turns OFF the tail lamp relay when the ignition switch is turned OFF</li> </ul>
Front wiper motor	<ul style="list-style-type: none"> <li>• The status just before activation of fail-safe control is maintained until the ignition switch is turned OFF while the front wiper is operating at LO or HI speed.</li> <li>• The wiper is operated at LO speed until the ignition switch is turned OFF if the fail-safe control is activated while the front wiper is set in the AUTO mode and the front wiper motor is operating.</li> <li>• Returns automatically wiper to stop position when ignition switch is turned ON if fail-safe control is activated while front wiper motor is operated and wiper stop in the other than stop position.</li> </ul>
Front fog lamp	Front fog lamp relay OFF
Horn	Horn relay OFF
Ignition relay	The status just before activation of fail-safe is maintained.
Starter motor	Starter control relay OFF

## IGNITION RELAY MALFUNCTION DETECTION FUNCTION

- IPDM E/R monitors the voltage at the contact circuit and excitation coil circuit of the ignition relay inside it.
- IPDM E/R judges the ignition relay error if the voltage differs between the contact circuit and the excitation coil circuit.
- If the ignition relay cannot turn OFF due to contact seizure, it activates the tail lamp relay and daytime running light relay for 10 minutes to alert the user to the ignition relay malfunction when the ignition switch is turned OFF.

Voltage judgment		IPDM E/R judgment	Operation
Ignition relay contact side	Ignition relay excitation coil side		
ON	ON	Ignition relay ON normal	—
OFF	OFF	Ignition relay OFF normal	—
ON	OFF	Ignition relay ON stuck	<ul style="list-style-type: none"> <li>• Detects DTC "B2098: IGN RELAY ON"</li> <li>• Turns ON the tail lamp relay for 10 minutes</li> </ul>
OFF	ON	Ignition relay OFF stuck	Detects DTC "B2099: IGN RELAY OFF"

## FRONT WIPER PROTECTION FUNCTION

IPDM E/R detects front wiper stop position by a front wiper stop position signal. When a front wiper stop position signal is in the conditions listed below, IPDM E/R stops power supply to wiper after repeating a front wiper 10 seconds activation and 20 seconds stop five times.

# SYSTEM

< SYSTEM DESCRIPTION >

[IPDM E/R]

Ignition switch	Front wiper switch	Front wiper stop position signal
ON	OFF	The front wiper stop position signal (stop position) cannot be input for 10 seconds.
	ON	The front wiper stop position signal does not change for 10 seconds.

**NOTE:**

This operation status can be confirmed on the IPDM E/R “Data Monitor” that displays “BLOCK” for the item “WIP PROT” while the wiper is stopped.

**STARTER MOTOR PROTECTION FUNCTION**

IPDM E/R turns OFF the starter control relay to protect the starter motor when the starter control relay remains active for 90 seconds.

**POWER CONTROL SYSTEM**

**POWER CONTROL SYSTEM : System Description**

INFOID:000000008380870

**SYSTEM DIAGRAM**

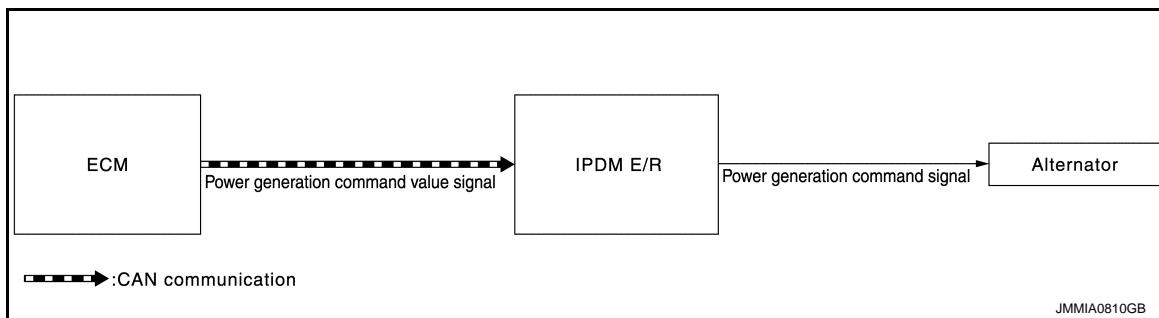

**DESCRIPTION**

**Alternator Control**

IPDM E/R outputs power generation command signal (PWM signal) to the alternator according to the status of the power generation command value signal received from ECM via CAN communication. Refer to [CHG-7, "CHARGING SYSTEM : System Description"](#).

**SIGNAL BUFFER SYSTEM**

**SIGNAL BUFFER SYSTEM : System Description**

INFOID:000000008380871

**SYSTEM DIAGRAM**

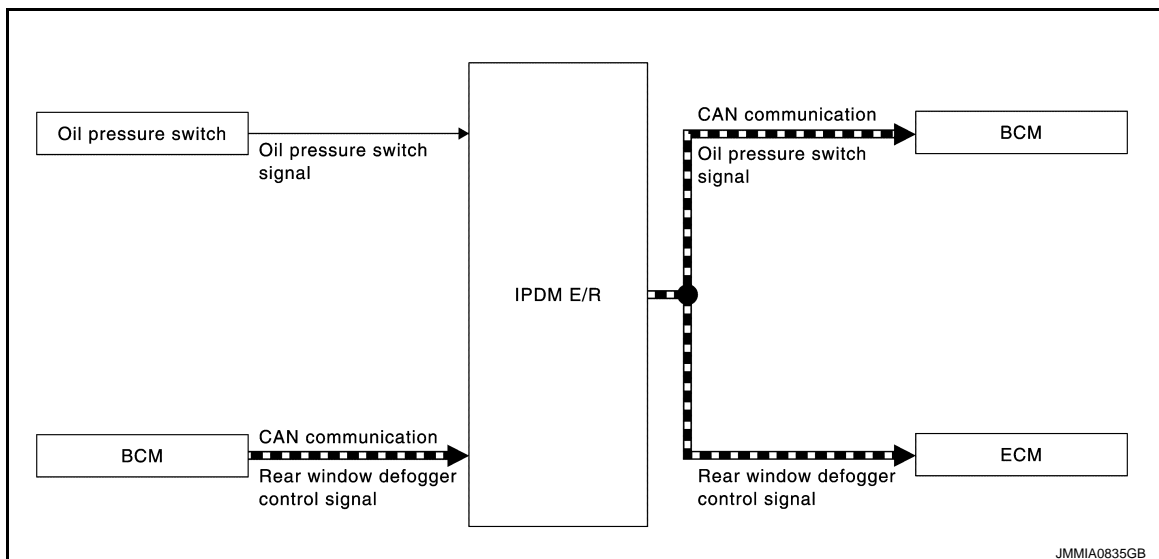

**DESCRIPTION**

- IPDM E/R reads the status of the oil pressure switch and transmits the oil pressure switch signal to BCM via CAN communication. Refer to [MWI-16, "OIL PRESSURE WARNING LAMP : System Description"](#).



# SYSTEM

[IPDM E/R]

## < SYSTEM DESCRIPTION >

- IPDM E/R receives the rear window defogger control signal from BCM via CAN communication and transmits it to ECM via CAN communication. Refer to [DEF-6, "System Description"](#).

## POWER CONSUMPTION CONTROL SYSTEM

### POWER CONSUMPTION CONTROL SYSTEM : System Diagram

INFOID:000000008380872

### POWER CONSUMPTION CONTROL SYSTEM : System Description

INFOID:000000008380873

#### SYSTEM DIAGRAM

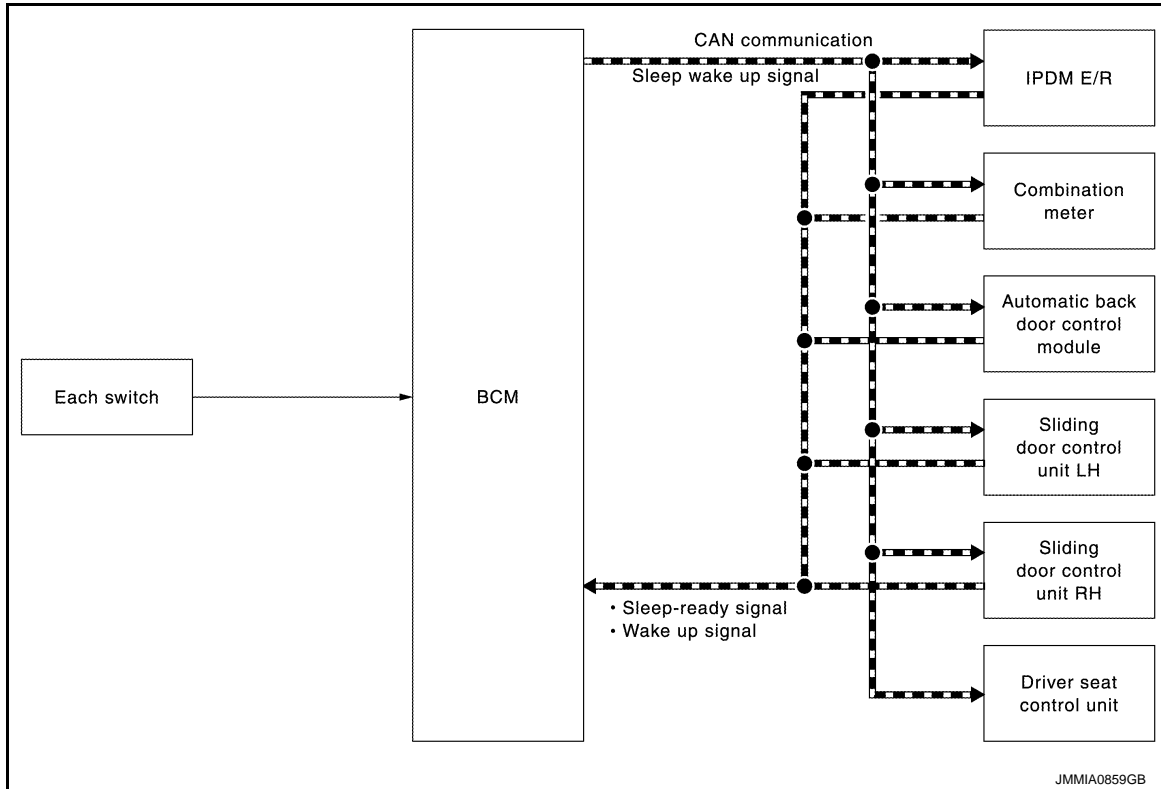

#### DESCRIPTION

##### Outline

- IPDM E/R incorporates a power consumption control function that reduces the power consumption according to the vehicle status.
- IPDM E/R changes its status (control mode) with the sleep wake up signal received from BCM via CAN communication.

##### Normal mode (wake-up)

- CAN communication is normally performed with other control units.
- Individual unit control by IPDM E/R is normally performed.

##### Low power consumption mode (sleep)

- Low power consumption control is active.
- CAN transmission is stopped.

##### Sleep Mode Activation

- IPDM E/R judges that the sleep-ready conditions are fulfilled when the ignition switch is OFF and none of the conditions below are present. Then it transmits a sleep-ready signal (ready) to BCM via CAN communication.
  - Outputting signals to actuators
  - Switches or relays operating
  - Output requests are being received from control units via CAN communication.
- IPDM E/R stops CAN communication and enters the low power consumption mode when it receives a sleep wake up signal (sleep) from BCM and the sleep-ready conditions are fulfilled.

##### Wake-up Operation

A

B

C

D

E

F

G

H

I

J

K

L

PCS

N

O

P

## SYSTEM

[IPDM E/R]

### < SYSTEM DESCRIPTION >

---

- IPDM E/R changes from the low power consumption mode to the normal mode when it receives a sleep wake-up signal (wake up) from BCM or any of the following conditions is fulfilled. In addition, it transmits a sleep-ready signal (not-ready) to BCM via CAN communication to report the CAN communication start.
- Ignition switch ON
- An output request is received from a control unit via CAN communication.

## DIAGNOSIS SYSTEM (IPDM E/R)

### Diagnosis Description

INFOID:000000008380874

#### AUTO ACTIVE TEST

##### Description

In auto active test, the IPDM E/R sends a drive signal to the following systems to check their operation.

- Oil pressure warning lamp
- Front wiper (LO, HI)
- Parking lamp
- License plate lamp
- Tail lamp
- Side marker lamp
- Front fog lamp
- Headlamp (LO, HI)
- A/C compressor (magnet clutch)
- Cooling fan

##### Operation Procedure

##### NOTE:

Never perform auto active test in the following condition.

- Passenger door is open.
  - CONSULT is connected.
1. Close the hood and lift the wiper arms from the windshield. (Prevent windshield damage due to wiper operation)  
**NOTE:**  
 When auto active test is performed with hood opened, sprinkle water on windshield beforehand.
  2. Turn the ignition switch OFF.
  3. Turn the ignition switch ON, and within 20 seconds, press the front door switch (driver side) 10 times. Then turn the ignition switch OFF.
  4. Turn the ignition switch ON within 10 seconds. After that the horn sounds once and the auto active test starts.  
**NOTE:**  
 Engine starts when ignition switch is turned ON while brake pedal is depressed.
  5. The oil pressure warning lamp starts blinking when the auto active test starts.
  6. After a series of the following operations is repeated 3 times, auto active test is completed.

##### NOTE:

- When auto active test has to be cancelled halfway through test, turn the ignition switch OFF.
- When auto active test is not activated, door switch may be the cause. Check door switch. Refer to [DLK-210, "Component Function Check"](#).

##### Inspection in Auto Active Test

When auto active test is actuated, the following 6 steps are repeated 3 times.

Operation sequence	Inspection location	Operation
1	Oil pressure warning lamp	Blinks continuously during operation of auto active test
2	Front wiper motor	LO for 5 seconds → HI for 5 seconds
3	<ul style="list-style-type: none"> <li>• Parking lamp</li> <li>• License plate lamp</li> <li>• Tail lamp</li> <li>• Side marker lamp</li> <li>• Front fog lamp</li> </ul>	10 seconds
4	Headlamp	<ul style="list-style-type: none"> <li>• LO 10 seconds</li> <li>• HI ON ↔ OFF 5 times</li> </ul>
5	A/C compressor (magnet clutch)	ON ↔ OFF 5 times
6	Cooling fan	LO for 5 seconds → MID for 3 seconds → HI for 2 seconds

# DIAGNOSIS SYSTEM (IPDM E/R)

< SYSTEM DESCRIPTION >

[IPDM E/R]

Concept of auto active test

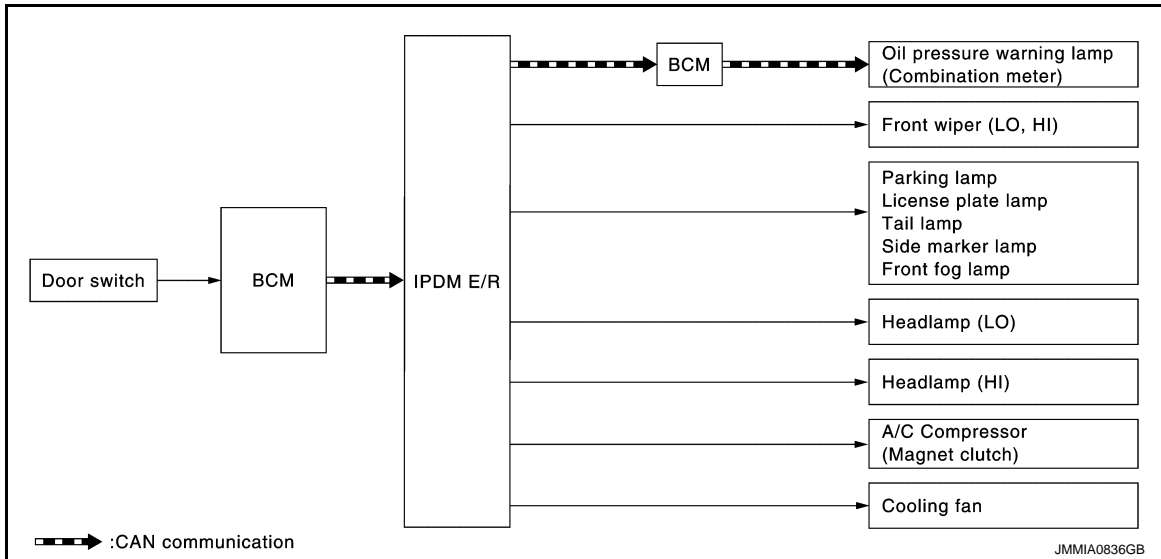

- IPDM E/R starts the auto active test with the door switch signals transmitted by BCM via CAN communication. Therefore, the CAN communication line between IPDM E/R and BCM is considered normal if the auto active test starts successfully.
- The auto active test facilitates troubleshooting if any systems controlled by IPDM E/R cannot be operated.

Diagnosis chart in auto active test

Symptom	Inspection contents	Possible cause
Any of the following components do not operate • Parking lamp • License plate lamp • Tail lamp • Side marker lamp • Front fog lamp • Headlamp (HI, LO) • Front wiper motor	Perform auto active test. Does the applicable system operate?	YES BCM signal input circuit
		NO • Lamp or motor • Lamp or motor ground circuit • Harness or connector between IPDM E/R and applicable system • IPDM E/R
A/C compressor does not operate	Perform auto active test. Does the magnet clutch operate?	YES • Combination meter signal input circuit • CAN communication signal between Combination meter and ECM • CAN communication signal between ECM and IPDM E/R
		NO • Magnet clutch • Harness or connector between IPDM E/R and magnet clutch • IPDM E/R
Oil pressure warning lamp does not operate	Perform auto active test. Does the oil pressure warning lamp blink?	YES • Harness or connector between IPDM E/R and oil pressure switch • Oil pressure switch • IPDM E/R
		NO • CAN communication signal between IPDM E/R and BCM • CAN communication signal between BCM and Combination meter • Combination meter

# DIAGNOSIS SYSTEM (IPDM E/R)

< SYSTEM DESCRIPTION >

[IPDM E/R]

Symptom	Inspection contents	Possible cause
Cooling fan does not operate	Perform auto active test. Does the cooling fan operate?	YES <ul style="list-style-type: none"> <li>• ECM signal input circuit</li> <li>• CAN communication signal between ECM and IPDM E/R</li> </ul>
		NO <ul style="list-style-type: none"> <li>• Cooling fan</li> <li>• Harness or connector between cooling fan and cooling fan relay</li> <li>• Harness or connector between IPDM E/R and cooling fan relay</li> <li>• Cooling fan relay</li> <li>• IPDM E/R</li> </ul>

A  
B  
C  
D

## CONSULT Function (IPDM E/R)

INFOID:000000008380875

### APPLICATION ITEM

CONSULT performs the following functions via CAN communication with IPDM E/R.

Diagnosis mode	Description
Ecu Identification	Allows confirmation of IPDM E/R part number.
Self Diagnostic Result	Displays the diagnosis results judged by IPDM E/R.
Data Monitor	Displays the real-time input/output data from IPDM E/R input/output data.
Active Test	IPDM E/R can provide a drive signal to electronic components to check their operations.
CAN Diag Support Monitor	The results of transmit/receive diagnosis of CAN communication can be read.

E  
F  
G  
H

### SELF DIAGNOSTIC RESULT

Refer to [PCS-24, "DTC Index"](#).

### DATA MONITOR

#### NOTE:

The following table includes information (items) inapplicable to this vehicle. For information (items) applicable to this vehicle, refer to CONSULT display items.

Monitor Item [Unit]	MAIN SIGNALS	Description
MOTOR FAN REQ [1/2/3/4]	×	Displays the value of the cooling fan speed signal received from ECM via CAN communication.
AC COMP REQ [Off/On]	×	Displays the status of the A/C compressor request signal received from ECM via CAN communication.
TAIL&CLR REQ [Off/On]	×	Displays the status of the position light request signal received from BCM via CAN communication.
HL LO REQ [Off/On]	×	Displays the status of the low beam request signal received from BCM via CAN communication.
HL HI REQ [Off/On]	×	Displays the status of the high beam request signal received from BCM via CAN communication.
FR FOG REQ [Off/On]	×	Displays the status of the front fog light request signal received from BCM via CAN communication.
FR WIP REQ [Stop/1LOW/Low/Hi]	×	Displays the status of the front wiper request signal received from BCM via CAN communication.
WIP AUTO STOP [STOP P/ACT P]	×	Displays the status of the front wiper stop position signal judged by IPDM E/R.
WIP PROT [Off/BLOCK]	×	Displays the status of the front wiper fail-safe operation judged by IPDM E/R.
IGN RLY1 -REQ [Off/On]		Displays the status of the ignition switch ON signal received from BCM via CAN communication.
IGN RLY [Off/On]	×	Displays the status of the ignition relay judged by IPDM E/R.

I  
J  
K  
L

PCS

N  
O  
P

# DIAGNOSIS SYSTEM (IPDM E/R)

< SYSTEM DESCRIPTION >

[IPDM E/R]

Monitor Item [Unit]	MAIN SIG- NALS	Description
PUSH SW [Off/On]		Displays the status of the push-button ignition switch judged by IPDM E/R.
INTER/NP SW [Off/On]		Displays the status of the shift position judged by IPDM E/R.
ST RLY CONT [Off/On]		Displays the status of the starter relay status signal received from BCM via CAN communication.
IHBT RLY -REQ [Off/On]		Displays the status of the starter control relay signal received from BCM via CAN communication.
ST/INH RLY [Off/ ST /INH/UNKWN]		Displays the status of the starter relay and starter control relay judged by IPDM E/R.
DETENT SW [Off/On]		Displays the status of the CVT shift selector (detention switch) judged by IPDM E/R.
S/L RLY -REQ [Off/On]		<b>NOTE:</b> The item is indicated, but not monitored.
S/L STATE [LOCK/UNLK/UNKWN]		<b>NOTE:</b> The item is indicated, but not monitored.
DTRL REQ [Off/On]		Displays the status of the daytime running light request signal received from BCM via CAN communication. <b>NOTE:</b> This item is monitored only on the vehicle with daytime running light system.
OIL P SW [Open/Close]		Displays the status of the oil pressure switch judged by IPDM E/R.
HOOD SW [Off/On]		<b>NOTE:</b> The item is indicated, but not monitored.
HL WASHER REQ [Off/On]		<b>NOTE:</b> The item is indicated, but not monitored.
THFT HRN REQ [Off/On]		Displays the status of the theft warning horn request signal received from BCM via CAN communication.
HORN CHIRP [Off/On]		Displays the status of the horn reminder signal received from BCM via CAN communication.
CRNRNG LMP REQ [Off/On]		<b>NOTE:</b> The item is indicated, but not monitored.

## ACTIVE TEST

Test item

Test item	Operation	Description
CORNERING LAMP	Off	<b>NOTE:</b> The item is indicated, but cannot be tested.
	LH	
	RH	
HORN	On	Operates horn relay for 20 ms.
FRONT WIPER	Off	OFF
	Lo	Operates the front wiper relay.
	Hi	Operates the front wiper relay and front wiper high relay.
MOTOR FAN	1	OFF
	2	Operates the cooling fan relay-1.
	3	Operates the cooling fan relay-2.
	4	Operates the cooling fan relay-2 and cooling fan relay-3.
HEAD LAMP WASHER	On	<b>NOTE:</b> The item is indicated, but cannot be tested.

# DIAGNOSIS SYSTEM (IPDM E/R)

< SYSTEM DESCRIPTION >

[IPDM E/R]

Test item	Operation	Description
EXTERNAL LAMPS	Off	OFF
	TAIL	Operates the tail lamp relay and the daytime running light relay.
	Lo	Operates the headlamp low relay.
	Hi	Operates the headlamp low relay and ON/OFF the headlamp high relay at 1 second intervals.
	Fog	Operates the front fog lamp relay.

A  
B  
C  
D  
E  
F  
G  
H  
I  
J  
K  
L

PCS

N  
O  
P

# ECU DIAGNOSIS INFORMATION

## IPDM E/R

### Reference Value

INFOID:000000008380876

### VALUES ON THE DIAGNOSIS TOOL

**NOTE:**

The following table includes information (items) inapplicable to this vehicle. For information (items) applicable to this vehicle, refer to CONSULT display items.

Monitor Item	Condition		Value/Status
MOTOR FAN REQ	Engine idle speed	Changes depending on engine coolant temperature, air conditioner operation status, vehicle speed, etc.	1/2/3/4
AC COMP REQ	Engine running	A/C switch OFF	Off
		A/C switch ON (compressor is operating)	On
TAIL&CLR REQ	Lighting switch OFF		Off
	Lighting switch 1ST, 2ND or AUTO (light is illuminated)		On
HL LO REQ	Lighting switch OFF		Off
	Lighting switch 2ND or AUTO (light is illuminated)		On
HL HI REQ	Lighting switch 2ND or AUTO (light is illuminated)	Lighting switch other than HI and PASS	Off
		Lighting switch HI or PASS	On
FR FOG REQ	Lighting switch 2ND or AUTO (light is illuminated)	Front fog lamp switch OFF	Off
		Lighting switch HI or PASS	
		Front fog lamp switch ON	On
FR WIP REQ	Ignition switch ON	Front wiper switch OFF	Stop
		Front wiper switch INT	1LOW
		Front wiper switch LO	Low
		Front wiper switch HI	Hi
WIP AUTO STOP	Ignition switch ON	Front wiper stop position	STOP P
		Any position other than front wiper stop position	ACT P
WIP PROT	Ignition switch ON	Front wiper operates normally	Off
		Front wiper stops at fail-safe operation	BLOCK
IGN RLY1 -REQ	Ignition switch OFF or ACC		Off
	Ignition switch ON		On
IGN RLY	Ignition switch OFF or ACC		Off
	Ignition switch ON		On
PUSH SW	Release the push-button ignition switch		Off
	Press the push-button ignition switch		On
INTER/NP SW	Ignition switch ON	Selector lever in any position other than P or N	Off
		Selector lever in P or N position	On
ST RLY CONT	Ignition switch ON		Off
	At engine cranking		On
IHBT RLY -REQ	Ignition switch ON		Off
	At engine cranking		On



# IPDM E/R

< ECU DIAGNOSIS INFORMATION >

[IPDM E/R]

Monitor Item	Condition	Value/Status	
ST/INHI RLY	Ignition switch ON	Off	A
	At engine cranking	INHI → ST	
	The status of starter relay or starter control relay cannot be recognized by the battery voltage malfunction, etc. when the starter relay is ON and the starter control relay is OFF	UNKWN	B
DETENT SW	Ignition switch ON	Off	C
	Release the selector button with selector lever in P position	On	D
S/L RLY -REQ	<b>NOTE:</b> The item is indicated, but not monitored.	Off	
S/L STATE	<b>NOTE:</b> The item is indicated, but not monitored.	UNLK	E
DTRL REQ	Daytime running light system is not operated	Off	
	Daytime running light system is operated	On	F
OIL P SW	Ignition switch OFF or ACC	Open	
	Ignition switch ON (engine running)		G
	Ignition switch ON (engine stopped)	Close	
HOOD SW	<b>NOTE:</b> The item is indicated, but not monitored.	Off	H
HL WASHER REQ	<b>NOTE:</b> The item is indicated, but not monitored.	Off	
THFT HRN REQ	Not operation	Off	I
	<ul style="list-style-type: none"> <li>• Panic alarm is activated</li> <li>• Theft warning alarm is activated</li> </ul>	On	
HORN CHIRP	Not operation	Off	J
	Door locking with Intelligent Key (horn chirp mode)	On	
CRNRNG LMP REQ	<b>NOTE:</b> The item is indicated, but not monitored.	Off	K

L

PCS

N

O

P

TERMINAL LAYOUT

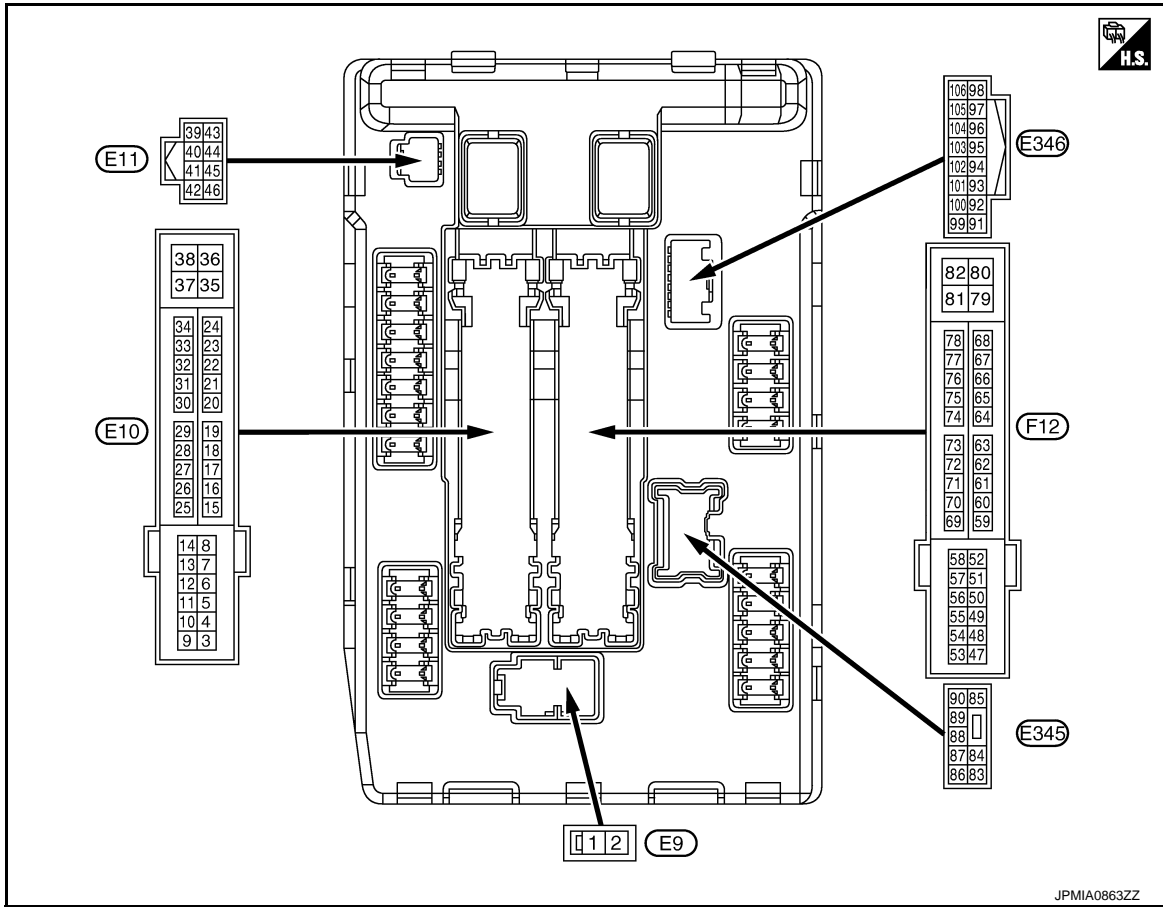

PHYSICAL VALUES

Terminal No. (Wire color)		Description		Condition		Value (Approx.)
+	-	Signal name	Input/ Output			
1 (R)	Ground	Battery power supply	Input	Ignition switch OFF		6 – 16 V
2 (L)	Ground	Battery power supply	Input	Ignition switch OFF		6 – 16 V
4 (LG)	Ground	Front wiper LO	Output	Ignition switch OFF	Front wiper switch OFF	0 – 1 V
				Ignition switch ON	Front wiper switch LO	9 – 16 V
5 (Y)	Ground	Front wiper HI	Output	Ignition switch OFF	Front wiper switch OFF	0 – 1 V
				Ignition switch ON	Front wiper switch HI	9 – 16 V
6 (G)	Ground	Daytime running light relay power supply	Input	Ignition switch OFF		6 – 16 V
7 (BR)	Ground	Illuminations	Output	Lighting switch OFF		0 – 1 V
				Lighting switch 1ST		9 – 16 V
10 (P)	Ground	ECM relay power supply	Output	Ignition switch OFF (More than a few seconds after turning ignition switch OFF)		0 – 1 V
				<ul style="list-style-type: none"> <li>Ignition switch ON</li> <li>Ignition switch OFF (For a few seconds after turning ignition switch OFF)</li> </ul>		6 – 16 V
12 (B)	Ground	Ground	—	Ignition switch ON		0 – 1 V

# IPDM E/R

< ECU DIAGNOSIS INFORMATION >

[IPDM E/R]

Terminal No. (Wire color)		Description		Condition	Value (Approx.)	
		Signal name	Input/ Output			
+	-					
13 (G)	Ground	Fuel pump power supply	Output	Approximately 1 second or more after turning the ignition switch ON	0 – 1 V	A
				<ul style="list-style-type: none"> <li>• Approximately 1 second after turning the ignition switch ON</li> <li>• Engine running</li> </ul>	6 – 16 V	B
15 (L)	Ground	Ignition power supply	Output	Ignition switch OFF or ACC	0 – 1 V	C
				Ignition switch ON	6 – 16 V	D
16 (R)	Ground	Front wiper stop position	Input	Ignition switch ON	Front wiper stop position	0 – 1 V
					Any position other than front wiper stop position	9 – 16 V
18 (P)	Ground	Ignition power supply No. 2	Input	Ignition switch OFF or ACC	0 – 1 V	F
				Ignition switch ON	6 – 16 V	G
19 (V)	Ground	Ignition relay power supply	Output	Ignition switch OFF or ACC	0 – 1 V	H
				Ignition switch ON	6 – 16 V	I
20 (W)	Ground	Ambient sensor ground	Output	Ignition switch ON	0 – 1 V	J
21 (O)	Ground	Ambient sensor	Input	Ignition switch ON	0 – 4.8 V <b>NOTE:</b> Changes depending to ambient temperature	K
22 (SB)	Ground	Refrigerant pressure sensor ground	Output	Engine running	<ul style="list-style-type: none"> <li>• Warm-up condition</li> <li>• Idle speed</li> </ul>	L
23 (GR)	Ground	Refrigerant pressure sensor	Output	Engine running	<ul style="list-style-type: none"> <li>• Warm-up condition</li> <li>• Both A/C switch and blower fan motor switch ON (Compressor operates)</li> </ul>	M
24 (G)	Ground	Refrigerant pressure sensor power supply	Input	Ignition switch ON	5 V	N
25 (GR)	Ground	Ignition relay power supply	Output	Ignition switch OFF or ACC	0 – 1 V	O
				Ignition switch ON	6 – 16 V	P
27 (BR)	Ground	Ignition relay monitor	Input	Ignition switch OFF or ACC	6 – 16 V	PCS
				Ignition switch ON	0 – 1 V	N
28 (G)	Ground	Push-button ignition switch	Input	Press the push-button ignition switch	0 – 1 V	O
				Release the push-button ignition switch	6 – 16 V	P
30 (LG)	Ground	Starter relay control	Input	Ignition switch ON	Selector lever in any position other than P or N	6 – 16 V
					Selector lever P or N	0 – 1 V
34 (O)	Ground	Cooling fan relay-3 control	Input	Cooling fan stopped	6 – 16 V	P
				Cooling fan at HI operation	0 – 1 V	PCS
35 (P)	Ground	Cooling fan relay-1 power supply	Input	Cooling fan stopped	6 – 16 V	O
				Cooling fan at LO operation	4 – 8 V	P
36 (G)	Ground	Battery power supply	Input	Ignition switch OFF	6 – 16 V	
38 (GR)	Ground	Cooling fan relay-2 power supply	Output	Cooling fan not operation	0 – 1 V	
				Cooling fan at LO operation	4 – 8 V	
				Cooling fan at HI operation	9 – 16 V	

# IPDM E/R

< ECU DIAGNOSIS INFORMATION >

[IPDM E/R]

Terminal No. (Wire color)		Description		Condition	Value (Approx.)	
+	-	Signal name	Input/ Output			
39 (P)	—	CAN-L	Input/ Output	—	—	
40 (L)	—	CAN-H	Input/ Output	—	—	
41 (B)	Ground	Ground	—	Ignition switch ON	0 – 1 V	
42 (SB)	Ground	Cooling fan relay-2 control	Input	Cooling fan stopped	9 – 16 V	
				<ul style="list-style-type: none"> <li>• Cooling fan at MID operation</li> <li>• Cooling fan at HI operation</li> </ul>	0 – 1 V	
43 (LG)	Ground	CVT shift selector (Detention switch)	Input	Ignition switch ON	<ul style="list-style-type: none"> <li>• Press the selector but- ton (selector lever P)</li> <li>• Selector lever in any position other than P</li> </ul>	9 – 16 V
				Release the selector but- ton (selector lever P)	0 – 1 V	
44 (W)	Ground	Horn relay control	Input	The horn is deactivated	9 – 16 V	
				The horn is activated	0 – 1 V	
45 (Y)	Ground	Horn switch	Input	The horn is deactivated	9 – 16 V	
				The horn is activated	0 – 1 V	
46 (O)	Ground	Starter relay control	Input	At engine cranking	0 – 1 V	
				Other than at engine cranking	6 – 16 V	
48 (W)	Ground	A/C relay power supply	Output	Engine run- ning	A/C switch OFF	0 – 1 V
					A/C switch ON (A/C compressor is oper- ating)	9 – 16 V
49 (R/B)	Ground	ECM relay power sup- ply	Output	Ignition switch OFF or ACC	0 – 1 V	
				Ignition switch ON	6 – 16 V	
51 (LG)	Ground	Ignition relay power supply	Output	Ignition switch OFF or ACC	0 – 1 V	
				Ignition switch ON	6 – 16 V	
52 (Y/G)	Ground	Ignition relay power supply	Output	Ignition switch OFF or ACC	0 – 1 V	
				Ignition switch ON	6 – 16 V	
53 (R/W)	Ground	ECM relay power sup- ply	Output	Ignition switch OFF (More than a few seconds after turning igni- tion switch OFF)	0 – 1 V	
				<ul style="list-style-type: none"> <li>• Ignition switch ON</li> <li>• Ignition switch OFF (For a few seconds after turning ignition switch OFF)</li> </ul>	6 – 16 V	
54 (G/W)	Ground	Throttle control motor relay power supply	Output	Ignition switch OFF (More than a few seconds after turning igni- tion switch OFF)	0 – 1 V	
				<ul style="list-style-type: none"> <li>• Ignition switch ON</li> <li>• Ignition switch OFF (For a few seconds after turning ignition switch OFF)</li> </ul>	6 – 16 V	
55 (W/L)	Ground	ECM power supply	Output	Ignition switch OFF	6 – 16 V	
56 (R/Y)	Ground	Ignition relay power supply	Output	Ignition switch OFF or ACC	0 – 1 V	
				Ignition switch ON	6 – 16 V	

# IPDM E/R

< ECU DIAGNOSIS INFORMATION >

[IPDM E/R]

Terminal No. (Wire color)		Description		Condition	Value (Approx.)	
		Signal name	Input/ Output			
+	-					
57 (O)	Ground	Ignition relay power supply	Output	Ignition switch OFF or ACC	0 – 1 V	
				Ignition switch ON	6 – 16 V	
58 (Y)	Ground	Ignition relay power supply	Output	Ignition switch OFF or ACC	0 – 1 V	
				Ignition switch ON	6 – 16 V	
69 (W/B)	Ground	ECM relay control	Output	Ignition switch OFF (More than a few seconds after turning ignition switch OFF)	6 – 16 V	
				<ul style="list-style-type: none"> <li>• Ignition switch ON</li> <li>• Ignition switch OFF (For a few seconds after turning ignition switch OFF)</li> </ul>	0 – 1 V	
70 (O)	Ground	Throttle control motor relay control	Output	Ignition switch OFF or ACC	6 – 16 V	
				Ignition switch ON	0 – 1 V	
71 (P)	Ground	Cranking request	Output	Ignition switch OFF	0 – 1 V	
				Ignition switch ON	Selector lever P or N	9 – 16 V
					Selector lever in any position other than P or N	
72 (R/B)	Ground	Starter relay control	Input	Ignition switch ON	6 – 16 V	
				Selector lever P or N	0 – 1 V	
75 (LG)	Ground	Oil pressure switch	Input	Engine stopped	0 – 1 V	
				Engine running	9 – 16 V	
76 (GR)	Ground	Power generation command signal	Output	Ignition switch ON	<p style="text-align: right; margin-right: 50px;">JPMIA0001GB 6.6 V</p>	
				40% is set on "ACTIVE TEST", "ALTERNATOR DUTY" of "ENGINE"	<p style="text-align: right; margin-right: 50px;">JPMIA0002GB 4.0 V</p>	
				80% is set on "ACTIVE TEST", "ALTERNATOR DUTY" of "ENGINE"	<p style="text-align: right; margin-right: 50px;">JPMIA0003GB 1.3 V</p>	

A  
B  
C  
D  
E  
F  
G  
H  
I  
J  
K  
L

PCS

N  
O  
P

# IPDM E/R

< ECU DIAGNOSIS INFORMATION >

[IPDM E/R]

Terminal No. (Wire color)		Description		Condition		Value (Approx.)
+	-	Signal name	Input/ Output			
77 (B)	Ground	Fuel pump relay control	Output	<ul style="list-style-type: none"> <li>• Approximately 1 second after turning the ignition switch ON</li> <li>• Engine running</li> </ul>		0 – 1 V
				Approximately 1 second or more after turning the ignition switch ON		6 – 16 V
80 (B)	Ground	Starter motor	Output	Other than at engine cranking		0 – 1 V
				At engine cranking		6 – 16 V
83 (R)	Ground	Headlamp LO (RH)	Output	Lighting switch OFF		0 – 1 V
				Lighting switch 2ND or AUTO (light is illuminated)		9 – 16 V
84 (L)	Ground	Headlamp LO (LH)	Output	Lighting switch OFF		0 – 1 V
				Lighting switch 2ND or AUTO (light is illuminated)		9 – 16 V
86 (SB)	Ground	Front fog lamp (RH)	Output	Lighting switch 2ND or AUTO (light is illuminated)	Front fog lamp switch ON	9 – 16 V
				Front fog lamp switch OFF		0 – 1 V
87 (Y)	Ground	Front fog lamp (LH)	Output	Lighting switch 2ND or AUTO (light is illuminated)	Front fog lamp switch ON	9 – 16 V
				Front fog lamp switch OFF		0 – 1 V
88 (BR)	Ground	Ignition relay power supply	Output	Ignition switch OFF or ACC		0 – 1 V
				Ignition switch ON		6 – 16 V
89 (V)	Ground	Headlamp HI (RH)	Output	Lighting switch 2ND or AUTO (light is illuminated)	Lighting switch HI or PASS	9 – 16 V
				Lighting switch other than HI and PASS		0 – 1 V
90 (G)	Ground	Headlamp HI (LH)	Output	Lighting switch 2ND or AUTO (light is illuminated)	Lighting switch HI or PASS	9 – 16 V
				Lighting switch other than HI and PASS		0 – 1 V
91 (LG)	Ground	Front combination lamp RH	Output	Lighting switch OFF		0 – 1 V
				Lighting switch 1ST		9 – 16 V
92 (P)	Ground	Front combination lamp LH	Output	Lighting switch OFF		0 – 1 V
				Lighting switch 1ST		9 – 16 V
93 (W)	Ground	Headlamp aiming motor RH	Output	Lighting switch OFF		0 – 1 V
				Lighting switch 1ST		9 – 16 V
94 (O)	Ground	Headlamp aiming motor LH	Output	Lighting switch OFF		0 – 1 V
				Lighting switch 1ST		9 – 16 V
99 (Y)	Ground	Ambient sensor ground	Output	Ignition switch ON		0 – 1 V
100 (V)	Ground	Ambient sensor	Input	Ignition switch ON		0 – 4.8 V <b>NOTE:</b> Changes depending to ambient temperature
101 (O)	Ground	Refrigerant pressure sensor ground	Output	Engine running	<ul style="list-style-type: none"> <li>• Warm-up condition</li> <li>• Idle speed</li> </ul>	0 – 1 V

Terminal No. (Wire color)		Description		Condition		Value (Approx.)
+	-	Signal name	Input/ Output			
102 (G)	Ground	Refrigerant pressure sensor	Output	Engine running	<ul style="list-style-type: none"> <li>• Warm-up condition</li> <li>• Both A/C switch and blower fan motor switch ON (Compressor operates)</li> </ul>	1 – 4 V
103 (BR)	Ground	Refrigerant pressure sensor power supply	Input	Ignition switch ON		5 V
105 (R)	Ground	Daytime running light relay control	Output	Daytime running light deactivated		9 – 16 V
				Daytime running light activated		0 – 1 V

Fail-safe

INFOID:000000008380877

CAN COMMUNICATION CONTROL

When CAN communication with ECM and BCM is impossible, IPDM E/R performs fail-safe control. After CAN communication recovers normally, it also returns to normal control.

If No CAN Communication Is Available With ECM

Control part	Fail-safe operation
Cooling fan	<ul style="list-style-type: none"> <li>• Turns ON the cooling fan relay-2 and the cooling fan relay-3 when the ignition switch is turned ON (Cooling fan operates at HI)</li> <li>• Turns OFF the cooling fan relay-1, the cooling fan relay-2 and the cooling fan relay-3 when the ignition switch is turned OFF (Cooling fan does not operate)</li> </ul>
A/C compressor	A/C relay OFF
Alternator	Outputs the power generation command signal (PWM signal) 0%

If No CAN Communication Is Available With BCM

Control part	Fail-safe operation
Headlamp	<ul style="list-style-type: none"> <li>• Turns ON the headlamp low relay when the ignition switch is turned ON</li> <li>• Turns OFF the headlamp low relay when the ignition switch is turned OFF</li> <li>• Headlamp high relay OFF</li> </ul>
<ul style="list-style-type: none"> <li>• Parking lamp</li> <li>• License plate lamp</li> <li>• Illumination</li> <li>• Tail lamp</li> <li>• Side marker lamp</li> </ul>	<ul style="list-style-type: none"> <li>• Turns ON the tail lamp relay when the ignition switch is turned ON</li> <li>• Turns OFF the tail lamp relay when the ignition switch is turned OFF</li> </ul>
Front wiper motor	<ul style="list-style-type: none"> <li>• The status just before activation of fail-safe control is maintained until the ignition switch is turned OFF while the front wiper is operating at LO or HI speed.</li> <li>• The wiper is operated at LO speed until the ignition switch is turned OFF if the fail-safe control is activated while the front wiper is set in the AUTO mode and the front wiper motor is operating.</li> <li>• Returns automatically wiper to stop position when ignition switch is turned ON if fail-safe control is activated while front wiper motor is operated and wiper stop in the other than stop position.</li> </ul>
Front fog lamp	Front fog lamp relay OFF
Horn	Horn relay OFF
Ignition relay	The status just before activation of fail-safe is maintained.
Starter motor	Starter control relay OFF

IGNITION RELAY MALFUNCTION DETECTION FUNCTION

- IPDM E/R monitors the voltage at the contact circuit and excitation coil circuit of the ignition relay inside it.
- IPDM E/R judges the ignition relay error if the voltage differs between the contact circuit and the excitation coil circuit.

< ECU DIAGNOSIS INFORMATION >

- If the ignition relay cannot turn OFF due to contact seizure, it activates the tail lamp relay and daytime running light relay for 10 minutes to alert the user to the ignition relay malfunction when the ignition switch is turned OFF.

Voltage judgment		IPDM E/R judgment	Operation
Ignition relay contact side	Ignition relay excitation coil side		
ON	ON	Ignition relay ON normal	—
OFF	OFF	Ignition relay OFF normal	—
ON	OFF	Ignition relay ON stuck	<ul style="list-style-type: none"> <li>• Detects DTC “B2098: IGN RELAY ON”</li> <li>• Turns ON the tail lamp relay for 10 minutes</li> </ul>
OFF	ON	Ignition relay OFF stuck	Detects DTC “B2099: IGN RELAY OFF”

FRONT WIPER PROTECTION FUNCTION

IPDM E/R detects front wiper stop position by a front wiper stop position signal. When a front wiper stop position signal is in the conditions listed below, IPDM E/R stops power supply to wiper after repeating a front wiper 10 seconds activation and 20 seconds stop five times.

Ignition switch	Front wiper switch	Front wiper stop position signal
ON	OFF	The front wiper stop position signal (stop position) cannot be input for 10 seconds.
	ON	The front wiper stop position signal does not change for 10 seconds.

**NOTE:**

This operation status can be confirmed on the IPDM E/R “Data Monitor” that displays “BLOCK” for the item “WIP PROT” while the wiper is stopped.

STARTER MOTOR PROTECTION FUNCTION

IPDM E/R turns OFF the starter control relay to protect the starter motor when the starter control relay remains active for 90 seconds.

DTC Index

INFOID:000000008380878

**NOTE:**

- The details of time display are as follows.
  - CRNT: A malfunction is detected now.
  - PAST: A malfunction was detected in the past.
- IGN counter is displayed on FFD (Freeze Frame Data).
  - The number is 0 when is detected now.
  - The number increases like 1 → 2 ... 38 → 39 after returning to the normal condition whenever IGN OFF → ON.
  - The number is fixed to 39 until the self-diagnosis results are erased if it is over 39.

×: Applicable

CONSULT display	Fail-safe	Reference
No DTC is detected. further testing may be required.	—	—
U1000: CAN COMM CIRCUIT	×	<a href="#">PCS-29</a>
B2098: IGN RELAY ON	×	<a href="#">PCS-30</a>
B2099: IGN RELAY OFF	—	<a href="#">PCS-31</a>
B209F: STR CUT OFF OPEN	—	<a href="#">SEC-91</a>
B20A0: STR CUT OFF SHORT	—	<a href="#">SEC-93</a>
B210B: START CONT RLY ON	—	<a href="#">SEC-95</a>
B210C: START CONT RLY OFF	—	<a href="#">SEC-97</a>
B210D: STARTER RELAY ON	—	<a href="#">SEC-99</a>
B210E: STARTER RELAY OFF	—	<a href="#">SEC-101</a>



# IPDM E/R

< ECU DIAGNOSIS INFORMATION >

[IPDM E/R]

CONSULT display	Fail-safe	Reference
B210F: INTRLCK/PNP SW ON	—	<a href="#">SEC-104</a>
B2110: INTRLCK/PNP SW OFF	—	<a href="#">SEC-106</a>

A  
B  
C  
D  
E  
F  
G  
H  
I  
J  
K  
L  
N  
O  
P

PCS

< WIRING DIAGRAM >

# WIRING DIAGRAM

## IPDM E/R

### Wiring Diagram

INFOID:000000008380879

For connector terminal arrangements, harness layouts, and alphabets in a  (option abbreviation; if not described in wiring diagram), refer to [GI-12. "Connector Information"](#).

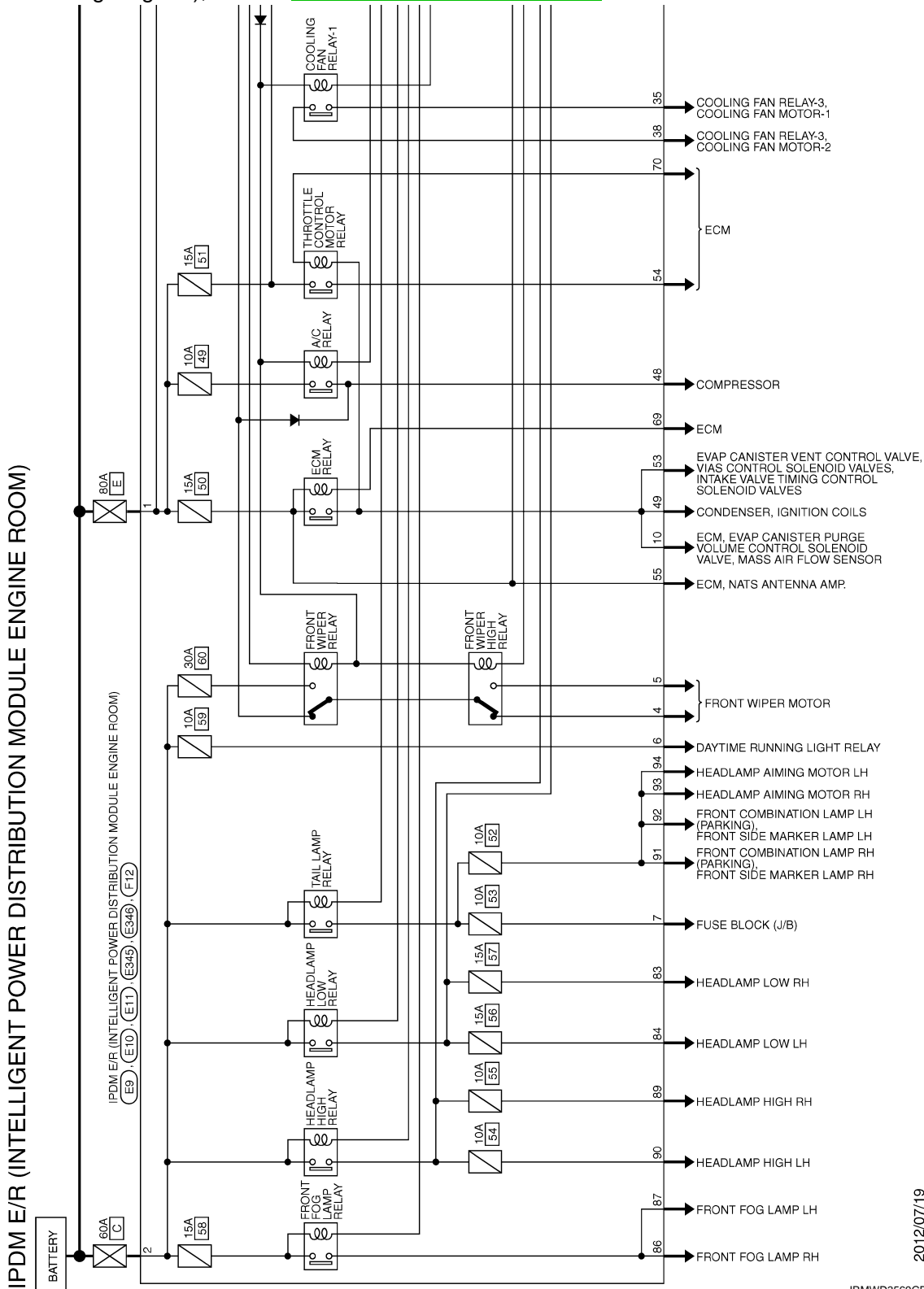

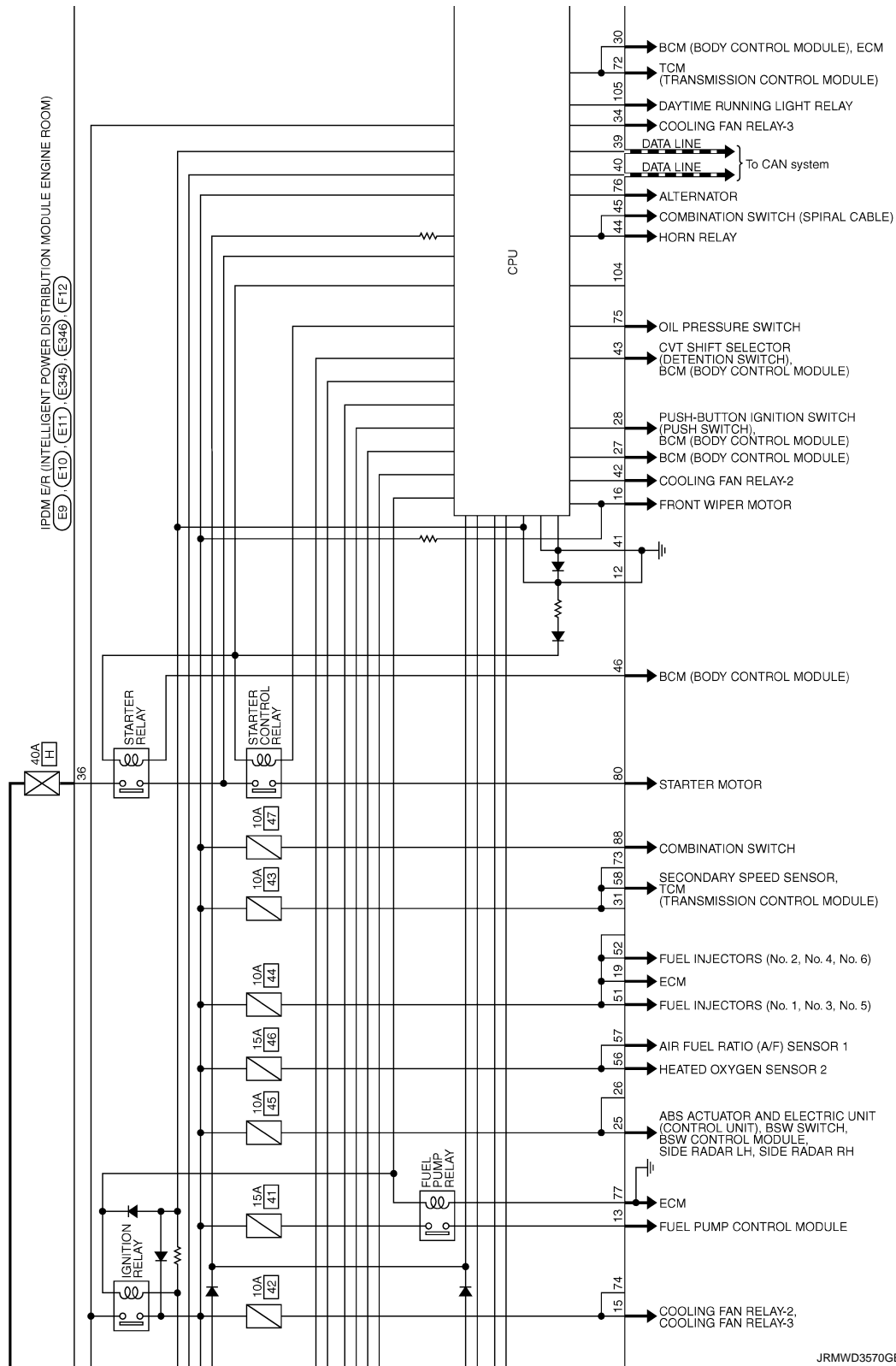

JRMWD3570GB

A  
B  
C  
D  
E  
F  
G  
H  
I  
J  
K  
L  
PCS  
N  
O  
P

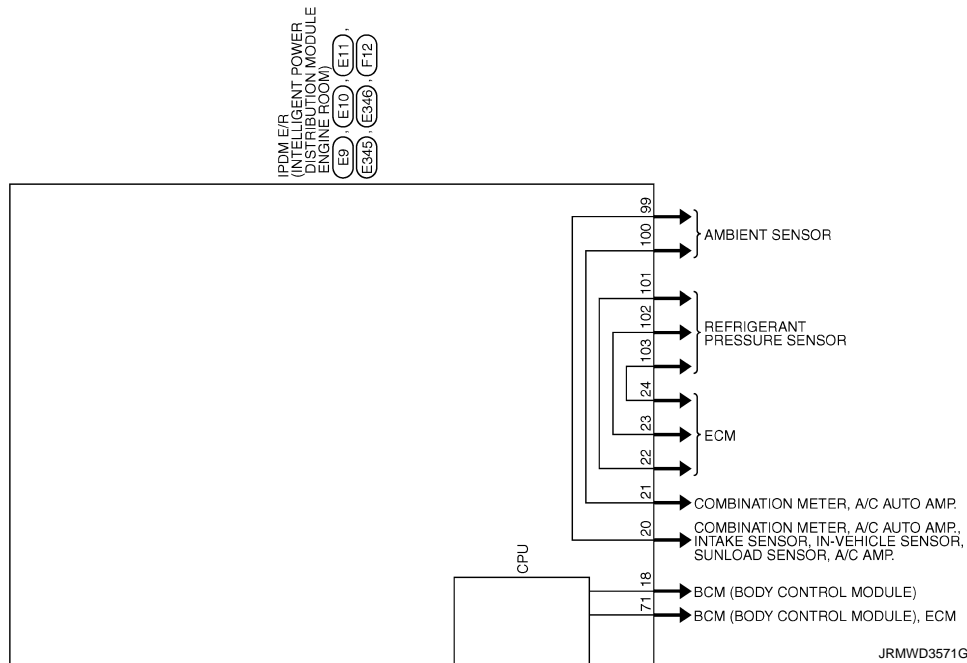

## DTC/CIRCUIT DIAGNOSIS

### U1000 CAN COMM CIRCUIT

#### Description

INFOID:000000008380880

CAN (Controller Area Network) is a serial communication line for real time applications. It is an on-vehicle multiplex communication line with high data communication speed and excellent error detection ability. Modern vehicle is equipped with many electronic control unit, and each control unit shares information and links with other control units during operation (not independent). In CAN communication, control units are connected with 2 communication lines (CAN-H line, CAN-L line) allowing a high rate of information transmission with less wiring. Each control unit transmits/receives data but selectively reads required data only.

CAN Communication Signal Chart. Refer to [LAN-32, "CAN COMMUNICATION SYSTEM : CAN Communication Signal Chart"](#).

#### DTC Logic

INFOID:000000008380881

#### DTC DETECTION LOGIC

DTC	CONSULT display description	DTC Detection Condition	Possible cause
U1000	CAN COMM CIRCUIT	When IPDM E/R cannot communicate CAN communication signal continuously for 2 seconds or more	CAN communication system

#### Diagnosis Procedure

INFOID:000000008380882

#### 1. PERFORM SELF DIAGNOSTIC

1. Turn ignition switch ON and wait 2 seconds or more.
2. Check "Self Diagnostic Result" of "IPDM E/R" using CONSULT.

Is DTC "U1000" displayed?

- YES >> Refer to [LAN-17, "Trouble Diagnosis Flow Chart"](#).
- NO >> Refer to [GI-42, "Intermittent Incident"](#).

PCS

# B2098 IGNITION RELAY ON STUCK

< DTC/CIRCUIT DIAGNOSIS >

[IPDM E/R]

## B2098 IGNITION RELAY ON STUCK

### Description

INFOID:000000008380883

- IPDM E/R operates the ignition relay when it receives an ignition switch ON signal from BCM via CAN communication.
- Turn the ignition relay OFF by pressing the push-button ignition switch once when the vehicle speed is 4 km/h (2.5 MPH) or less.
- Turn the ignition relay OFF with the following operation when the vehicle speed is more than 4 km/h (2.5 MPH) or when an abnormal condition occurs in CAN communication from the unified meter and A/C amp.(Emergency OFF)
  - Press and hold the push-button ignition switch for 2 seconds or more.
  - Press the push-button ignition switch 3 times within 1.5 seconds.

#### NOTE:

The ignition relay does not turn ON for 3 seconds after emergency OFF even if the push-button ignition switch is pressed.

### DTC Logic

INFOID:000000008380884

#### DTC DETECTION LOGIC

DTC	CONSULT display description	DTC Detection Condition	Possible causes
B2098	IGN RELAY ON	The ignition relay ON is detected for 1 second at ignition switch OFF (CPU monitors the status at the contact and excitation coil circuits of the ignition relay inside it)	Ignition relay malfunction

#### 1.PERFORM DTC CONFIRMATION PROCEDURE

1. Turn ignition switch ON.
2. Check DTC in "Self Diagnostic Result" mode of "IPDM E/R" using CONSULT.

#### Is DTC detected?

- YES >> Refer to [PCS-30, "Diagnosis Procedure"](#).
- NO >> INSPECTION END.

### Diagnosis Procedure

INFOID:000000008380885

#### 1.PERFORM SELF DIAGNOSIS

1. Turn ignition switch OFF, and wait 1 second or more.
2. Turn ignition switch ON.
3. Check "Self Diagnostic Result" of "IPDM E/R" using CONSULT.

#### Is DTC "B2098" displayed?

- YES >> Replace IPDM E/R. Refer to [PCS-33, "Removal and Installation"](#).
- NO >> Refer to [GI-42, "Intermittent Incident"](#).

# B2099 IGNITION RELAY OFF STUCK

< DTC/CIRCUIT DIAGNOSIS >

[IPDM E/R]

## B2099 IGNITION RELAY OFF STUCK

### Description

INFOID:000000008380886

- IPDM E/R operates the ignition relay when it receives an ignition switch ON signal from BCM via CAN communication.
- Turn the ignition relay OFF by pressing the push-button ignition switch once when the vehicle speed is 4 km/h (2.5 MPH) or less.
- Turn the ignition relay OFF with the following operation when the vehicle speed is more than 4 km/h (2.5 MPH) or when an abnormal condition occurs in CAN communication from the unified meter and A/C amp.(Emergency OFF)
  - Press and hold the push-button ignition switch for 2 seconds or more.
  - Press the push-button ignition switch 3 times within 1.5 seconds.

#### NOTE:

The ignition relay does not turn ON for 3 seconds after emergency OFF even if the push-button ignition switch is pressed.

### DTC Logic

INFOID:000000008380887

#### DTC DETECTION LOGIC

DTC	CONSULT display description	DTC Detection Condition	Possible causes
B2099	IGN RELAY OFF	The ignition relay OFF is detected for 1 second at ignition switch ON (CPU monitors the status at the contact and excitation coil circuits of the ignition relay inside it)	Ignition relay malfunction

#### NOTE:

When IPDM E/R power supply voltage is low (Approx. 7 - 8 V for about 1 second), the "DTC: B2099" may be detected.

### 1.PERFORM DTC CONFIRMATION PROCEDURE

1. Turn ignition switch ON.
2. Check DTC in "Self Diagnostic Result" mode of "IPDM E/R" using CONSULT.

#### Is DTC detected?

- YES >> Refer to [PCS-31, "Diagnosis Procedure"](#).
- NO >> INSPECTION END.

### Diagnosis Procedure

INFOID:000000008380888

### 1.PERFORM SELF DIAGNOSIS

1. Turn ignition switch OFF, and wait 1 second or more.
2. Turn ignition switch ON.
3. Check "Self Diagnostic Result" of "IPDM E/R" using CONSULT.

#### Is "B2099" displayed?

- YES >> Replace IPDM E/R. Refer to [PCS-33, "Removal and Installation"](#).
- NO >> Refer to [GI-42, "Intermittent Incident"](#).

PCS

# POWER SUPPLY AND GROUND CIRCUIT

< DTC/CIRCUIT DIAGNOSIS >

[IPDM E/R]

## POWER SUPPLY AND GROUND CIRCUIT

### Diagnosis Procedure

INFOID:000000008380889

#### 1. CHECK FUSES AND FUSIBLE LINK

Check that the following IPDM E/R fuses or fusible links are not blown.

Signal name	Fuses and fusible link No.
Battery power supply	E (80 A)
	C (60 A)
	H (40 A)
	50 (15 A)
	51 (15 A)

Is the fuse fusing?

YES >> Replace the blown fuse or fusible link after repairing the affected circuit if a fuse or fusible link is blown.

NO >> GO TO 2.

#### 2. CHECK POWER SUPPLY CIRCUIT

1. Turn the ignition switch OFF.
2. Disconnect IPDM E/R connector.
3. Check voltage between IPDM E/R harness connector and the ground.

(+)		(-)	Voltage
IPDM E/R			
Connector	Terminal	Ground	6 – 16 V
E9	1		
	2		
E10	36		

Is the measurement value normal?

YES >> GO TO 3.

NO >> Repair the harness or connector.

#### 3. CHECK GROUND CIRCUIT

Check continuity between IPDM E/R harness connectors and the ground.

IPDM E/R		Ground	Continuity
Connector	Terminal		Existed
E10	12		
E11	41		

Does continuity exist?

YES >> INSPECTION END

NO >> Repair the harness or connector.



# REMOVAL AND INSTALLATION

## IPDM E/R

### Exploded View

INFOID:000000008380890

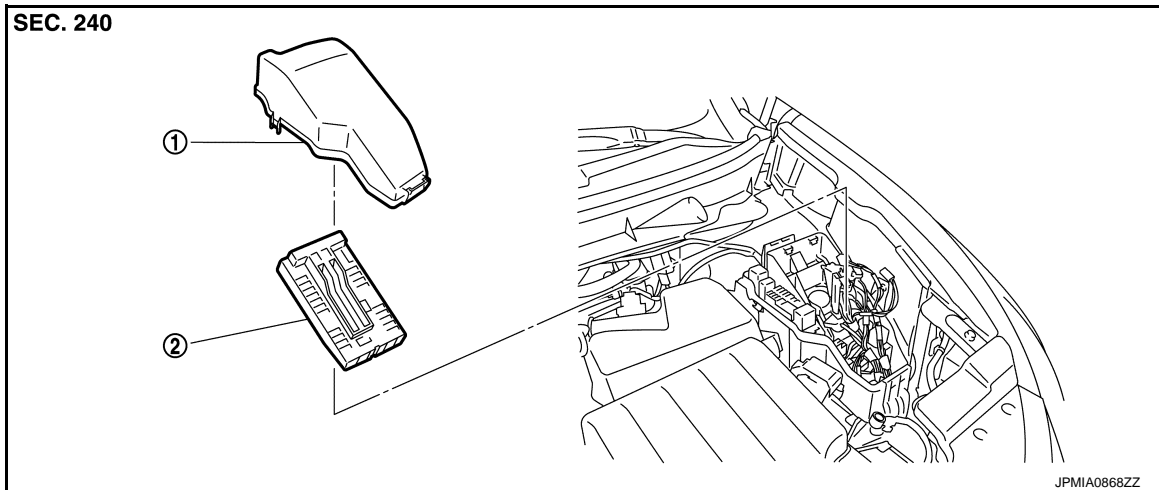

1. Relay box cover

2. IPDM E/R

## Removal and Installation

INFOID:000000008380891

### CAUTION:

**IPDM E/R integrated relays are not serviceable parts, and must not be removed from the unit.**

### REMOVAL

1. Disconnect the battery cable from the negative terminal.
2. Remove the relay box cover.
3. Disconnect the harness connector from the IPDM E/R (1).
4. Press the pawl (A) and remove the IPDM E/R from relay box.

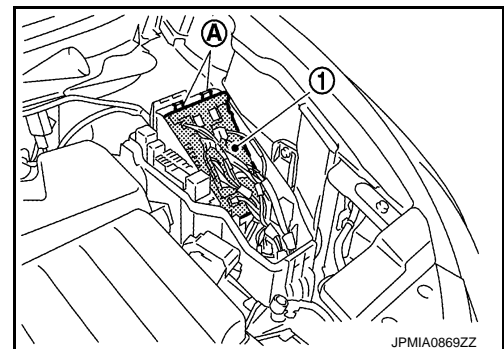

### INSTALLATION

Install in the reverse order of removal.

A  
B  
C  
D  
E  
F  
G  
H  
I  
J  
K  
L  
N  
O  
P

PCS

## PRECAUTION

### PRECAUTIONS

#### Precaution for Supplemental Restraint System (SRS) "AIR BAG" and "SEAT BELT PRE-TENSIONER"

INFOID:000000008380892

The Supplemental Restraint System such as "AIR BAG" and "SEAT BELT PRE-TENSIONER", used along with a front seat belt, helps to reduce the risk or severity of injury to the driver and front passenger for certain types of collision. This system includes seat belt switch inputs and dual stage front air bag modules. The SRS system uses the seat belt switches to determine the front air bag deployment, and may only deploy one front air bag, depending on the severity of a collision and whether the front occupants are belted or unbelted. Information necessary to service the system safely is included in the "SRS AIR BAG" and "SEAT BELT" of this Service Manual.

**WARNING:**

Always observe the following items for preventing accidental activation.

- To avoid rendering the SRS inoperative, which could increase the risk of personal injury or death in the event of a collision that would result in air bag inflation, all maintenance must be performed by an authorized NISSAN/INFINITI dealer.
- Improper maintenance, including incorrect removal and installation of the SRS, can lead to personal injury caused by unintentional activation of the system. For removal of Spiral Cable and Air Bag Module, see "SRS AIR BAG".
- Never use electrical test equipment on any circuit related to the SRS unless instructed to in this Service Manual. SRS wiring harnesses can be identified by yellow and/or orange harnesses or harness connectors.

#### PRECAUTIONS WHEN USING POWER TOOLS (AIR OR ELECTRIC) AND HAMMERS

**WARNING:**

Always observe the following items for preventing accidental activation.

- When working near the Air Bag Diagnosis Sensor Unit or other Air Bag System sensors with the ignition ON or engine running, never use air or electric power tools or strike near the sensor(s) with a hammer. Heavy vibration could activate the sensor(s) and deploy the air bag(s), possibly causing serious injury.
- When using air or electric power tools or hammers, always switch the ignition OFF, disconnect the battery, and wait at least 3 minutes before performing any service.

# COMPONENT PARTS

< SYSTEM DESCRIPTION >

[POWER DISTRIBUTION SYSTEM]

## SYSTEM DESCRIPTION

### COMPONENT PARTS

#### Component Parts Location

INFOID:0000000008380893

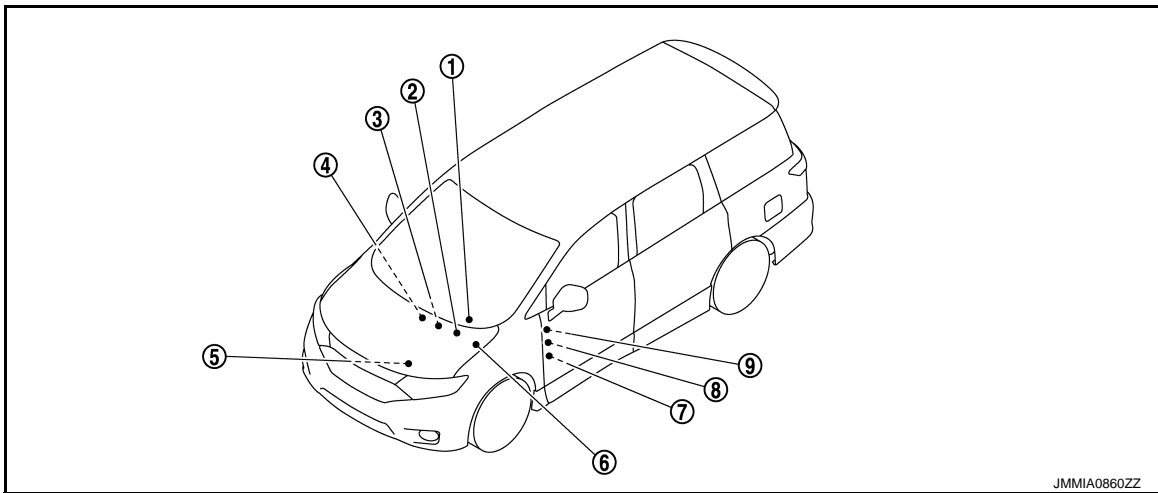

JMMIA0860ZZ

No.	Component	Description
1.	BCM	<ul style="list-style-type: none"> <li>• BCM controls power distribution system.</li> <li>• BCM judges ignition switch position by push-button ignition switch (push switch) and vehicle condition.</li> <li>• BCM checks the ignition switch position internally.</li> </ul> Refer to <a href="#">BCS-4. "BODY CONTROL SYSTEM : Component Parts Location"</a> for detailed installation location.
2.	Stop lamp relay	Stop lamp switch detects that brake pedal is depressed, and stop lamp relay transmits the signal to BCM. Refer to <a href="#">BRC-8. "Component Parts Location"</a> for detailed installation location.
3.	Push-button ignition switch	Push-button ignition switch (push switch) is pressed, and transmits the status signal to BCM and IPDM E/R.
4.	CVT shift selector (detention switch)	CVT shift selector (detention switch) detects shift lever status, transmits detention switch signal to BCM. Refer to <a href="#">TM-16. "SHIFT LOCK SYSTEM : Component Parts Location"</a> for detailed installation location.
5.	Transmission range switch	Transmission range switch detects shift position P or N, transmits P/N position signal to BCM. Refer to <a href="#">TM-10. "CVT CONTROL SYSTEM : Component Parts Location"</a> for detailed installation location.
6.	IPDM E/R	<ul style="list-style-type: none"> <li>• IPDM E/R detects push-button ignition switch (push switch) status, and transmits push-button ignition switch status signal (CAN) to BCM.</li> <li>• IPDM E/R receives ignition relay (IPDM E/R) control signal and ignition switch ON signal (CAN) from BCM, and controls ignition relay (built in IPDM E/R)</li> </ul> Refer to <a href="#">PCS-4. "IPDM E/R : Component Parts Location"</a> for detailed installation location.
7.	Blower relay (built in fuse block)	<ul style="list-style-type: none"> <li>• Blower relay is controlled by BCM.</li> <li>• Blower relay supplies the ignition switch ON power supply or the ignition switch ON signal to air conditioning system when ignition switch is turned ON.</li> <li>• BCM compares status of blower relay control signal and ignition switch position judged by BCM.</li> </ul>
8.	Accessory relay (built in fuse block)	<ul style="list-style-type: none"> <li>• Accessory relay is controlled by BCM.</li> <li>• Accessory relay supplies the accessory power supply or the ignition switch ACC signal to each ECU when ignition switch is turned ACC or ON.</li> <li>• BCM compares status of accessory relay control signal, and ignition switch position judged by BCM.</li> </ul>
9.	Ignition relay (built in fuse block)	<ul style="list-style-type: none"> <li>• Ignition relay is controlled by BCM.</li> <li>• Ignition relay supplies the ignition switch ON power supply or the ignition switch ON signal to each ECU and system when ignition switch is turned ON.</li> <li>• BCM compares status of ignition relay control signal and ignition switch position judged by BCM.</li> <li>• BCM monitors the ignition relay operating status by the ignition relay feedback signal.</li> </ul>

## SYSTEM

### POWER DISTRIBUTION SYSTEM

#### POWER DISTRIBUTION SYSTEM : System Description

INFOID:000000008380894

#### SYSTEM DIADRAM

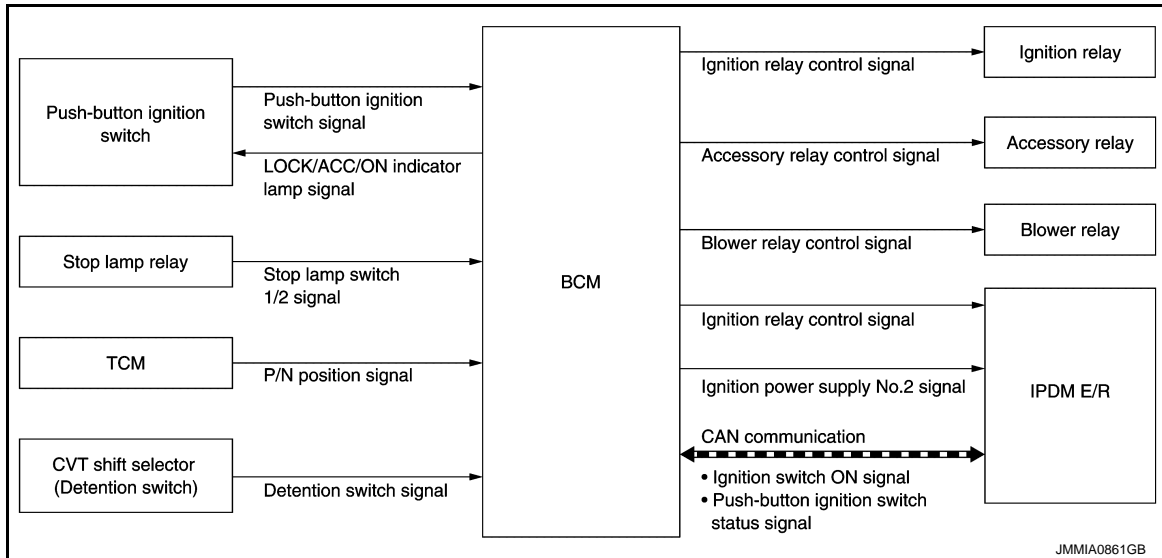

#### SYSTEM DESCRIPTION

- PDS (POWER DISTRIBUTION SYSTEM) is the system that BCM controls with the operation of the push-button ignition switch and performs the power distribution to each power circuit. This system is used instead of the mechanical power supply changing mechanism with the operation of the conventional key cylinder.
- The push-button ignition switch can be operated when Intelligent Key is in the following condition.
  - Intelligent Key is in the detection area of the inside key antenna.
  - Intelligent Key backside is contacted to push-button ignition switch.
- The push-button ignition switch operation is input to BCM as a signal. BCM changes the ignition switch position according to the status and operates the following relays to supply power to each power circuit.
  - Ignition relay (IPDM E/R)
  - Ignition relay [fuse block (J/B)]
  - Accessory relay
  - Blower relay
- The ignition switch position can be confirmed with the lighting of the LOCK/ACC/ON indicator lamp in the push-button ignition switch.

#### BATTERY SAVER SYSTEM

When all the following conditions are met for 60 minutes, the battery saver system will cut off the power supply (ignition switch position ACC → OFF) to prevent battery discharge.

- The ignition switch is in the ACC position
- All doors are closed
- Selector lever is in the P position

#### Reset Condition of Battery Saver System

If any of the following conditions are met the battery saver system is released.

- Opening any door
- Operating with door request switch on door lock
- Operating with Intelligent Key on door lock
- Change ignition switch position to ACC position from OFF position by pressing push-button ignition switch.

#### IGNITION SWITCH POSITION CHANGE TABLE BY PUSH-BUTTON IGNITION SWITCH OPERATION

Refer to [SEC-9. "INTELLIGENT KEY SYSTEM/ENGINE START FUNCTION : System Description"](#).

# SYSTEM

< SYSTEM DESCRIPTION >

[POWER DISTRIBUTION SYSTEM]

## Fail-safe

INFOID:000000008838567

### FAIL-SAFE CONTROL BY DTC

BCM performs fail-safe control when any DTC are detected.

Display contents of CONSULT	Fail-safe	Cancellation
B2192: ID DISCORD BCM-ECM	Inhibit engine cranking	Erase DTC
B2193: CHAIN OF BCM-ECM	Inhibit engine cranking	Erase DTC
B2195: ANTI-SCANNING	Inhibit engine cranking	Ignition switch ON → OFF
B2196: DONGLE NG	Inhibit engine cranking	Erase DTC
B2198: NATS ANTENNA AMP	Inhibit engine cranking	Erase DTC
B2608: STARTER RELAY	Inhibit engine cranking	500 ms after the following signal communication status becomes consistent <ul style="list-style-type: none"> <li>• Starter motor relay control signal</li> <li>• Starter relay status signal (CAN)</li> </ul>
B260F: ENG STATE SIG LOST	Inhibit engine cranking	When any of the following conditions are fulfilled <ul style="list-style-type: none"> <li>• Ignition switch changes to ACC</li> <li>• Receives engine status signal (CAN)</li> </ul>
B26F1: IGN RELAY OFF	Inhibit engine cranking	When the following conditions are fulfilled <ul style="list-style-type: none"> <li>• Ignition switch ON signal (CAN: Transmitted from BCM): ON</li> <li>• Ignition switch ON signal (CAN: Transmitted from IPDM E/R): ON</li> </ul>
B26F2: IGN RELAY ON	Inhibit engine cranking	When the following conditions are fulfilled <ul style="list-style-type: none"> <li>• Ignition switch ON signal (CAN: Transmitted from BCM): OFF</li> <li>• Ignition switch ON signal (CAN: Transmitted from IPDM E/R): OFF</li> </ul>
B26F3: START CONT RLY ON	Inhibit engine cranking	When the following conditions are fulfilled <ul style="list-style-type: none"> <li>• Starter control relay signal (CAN: Transmitted from BCM): OFF</li> <li>• Starter control relay signal (CAN: Transmitted from IPDM E/R): OFF</li> </ul>
B26F4: START CONT RLY OFF	Inhibit engine cranking	When the following conditions are fulfilled <ul style="list-style-type: none"> <li>• Starter control relay signal (CAN: Transmitted from BCM): ON</li> <li>• Starter control relay signal (CAN: Transmitted from IPDM E/R): ON</li> </ul>
B26F7: BCM	Inhibit engine cranking by Intelligent Key system	When room antenna and luggage room antenna functions normally

### REAR WIPER MOTOR PROTECTION

BCM detects the rear wiper stopping position according to the rear wiper stop position signal.

When the rear wiper stop position signal does not change for more than 5 seconds while driving the rear wiper, BCM stops power supply to protect the rear wiper motor.

Condition of cancellation

1. More than 1 minute is passed after the rear wiper stop.
2. Turn rear wiper switch OFF.
3. Operate the rear wiper switch or rear washer switch.

### FAIL-SAFE CONTROL OF COMBINATION SWITCH READING FUNCTION CAUSED BY LOW POWER SUPPLY VOLTAGE

If voltage of battery power supply lower, BCM maintains combination switch reading to the status when input voltage is less than approximately 9 V.

#### NOTE:

When voltage of battery power supply is approximately 9 V or more, combination switch reading function returns to normal operation.

# DIAGNOSIS SYSTEM (BCM)

[POWER DISTRIBUTION SYSTEM]

< SYSTEM DESCRIPTION >

## DIAGNOSIS SYSTEM (BCM)

### COMMON ITEM

COMMON ITEM : CONSULT Function (BCM - COMMON ITEM)

INFOID:000000008838565

### APPLICATION ITEM

CONSULT performs the following functions via CAN communication with BCM.

Diagnosis mode	Function Description
Work Support	Changes the setting for each system function.
Self Diagnostic Result	Displays the diagnosis results judged by BCM.
CAN Diag Support Monitor	Monitors the reception status of CAN communication viewed from BCM.
Data Monitor	The BCM input/output signals are displayed.
Active Test	The signals used to activate each device are forcibly supplied from BCM.
Ecu Identification	The BCM part number is displayed.
Configuration	<ul style="list-style-type: none"> <li>Read and save the vehicle specification.</li> <li>Write the vehicle specification when replacing BCM.</li> </ul>

### SYSTEM APPLICATION

BCM can perform the following functions for each system.

#### NOTE:

It can perform the diagnosis modes except the following for all sub system selection items.

×: Applicable item

System	Sub system selection item	Diagnosis mode		
		Work Support	Data Monitor	Active Test
Door lock	DOOR LOCK	×	×	×
Rear window defogger	REAR DEFOGGER		×	×
Warning chime	BUZZER		×	×
Interior room lamp control system	INT LAMP	×	×	×
Exterior lamp	HEAD LAMP	×	×	×
Wiper and washer	WIPER	×	×	×
Turn signal and hazard warning lamps	FLASHER	×	×	×
Air conditioning control system	AIR CONDITONER		×	×*
<ul style="list-style-type: none"> <li>Intelligent Key system</li> <li>Engine start system</li> </ul>	INTELLIGENT KEY	×	×	×
Combination switch	COMB SW		×	
Body control system	BCM	×		
NVIS	IMMU	×	×	×
Interior room lamp battery saver	BATTERY SAVER	×	×	×
Back door open	TRUNK		×	
Vehicle security system	THEFT ALM	×	×	×
RAP system	RETAINED PWR		×	
Signal buffer system	SIGNAL BUFFER		×	×
TPMS	AIR PRESSURE MONITOR	×	×	×

#### NOTE:

\*: For models with automatic air conditioning control system, this diagnosis mode is not used.

### FREEZE FRAME DATA (FFD)

The BCM records the following vehicle condition at the time a particular DTC is detected, and displays on CONSULT.

# DIAGNOSIS SYSTEM (BCM)

< SYSTEM DESCRIPTION >

[POWER DISTRIBUTION SYSTEM]

CONSULT screen item	Indication/Unit	Description	
Vehicle Speed	km/h	Vehicle speed of the moment a particular DTC is detected	A
Odo/Trip Meter	km	Total mileage (Odometer value) of the moment a particular DTC is detected	B
Vehicle Condition	SLEEP>LOCK	Power position status of the moment a particular DTC is detected*	B
	SLEEP>OFF		C
	LOCK>ACC		D
	ACC>ON		D
	RUN>ACC		E
	CRANK>RUN		E
	RUN>URGENT		F
	ACC>OFF		F
	OFF>LOCK		G
	OFF>ACC		G
	ON>CRANK		H
	OFF>SLEEP		H
	LOCK>SLEEP		I
	LOCK		I
	OFF		J
	ACC		J
	ON		K
ENGINE RUN	K		
CRANKING	K		
IGN Counter	0 - 39	The number of times that ignition switch is turned ON after DTC is detected <ul style="list-style-type: none"> <li>• The number is 0 when a malfunction is detected now.</li> <li>• The number increases like 1 → 2 → 3...38 → 39 after returning to the normal condition whenever ignition switch OFF → ON.</li> <li>• The number is fixed to 39 until the self-diagnosis results are erased if it is over 39.</li> </ul>	L

**NOTE:**

\*: Refer to the following for details of the power supply position.

- OFF (OFF, LOCK): Ignition switch OFF
- ACC: Ignition switch ACC
- IGN: Ignition switch ON with engine stopped
- RUN: Ignition switch ON with engine running
- CRANK: At engine cranking

Power supply position shifts to "OFF (LOCK)" from "OFF (OFF)", when ignition switch is in the OFF position, shift position is in the P position, and any of the following conditions are met.

- Closing door
- Opening door
- Door is locked using door request switch
- Door is locked using Intelligent Key

The power supply position shifts to "ACC" when the push-button ignition switch (push switch) is pushed at "OFF (LOCK)".

## INTELLIGENT KEY

PCS

N  
O  
P

# DIAGNOSIS SYSTEM (BCM)

< SYSTEM DESCRIPTION >

[POWER DISTRIBUTION SYSTEM]

## INTELLIGENT KEY : CONSULT Function (BCM - INTELLIGENT KEY)

INFOID:000000008838566

### WORK SUPPORT

Monitor item	Description
INSIDE ANT DIAGNOSIS	This function allows inside key antenna self-diagnosis
LOCK/UNLOCK BY I-KEY	Door lock/unlock function by door request switch mode can be changed to operation in this mode <ul style="list-style-type: none"> <li>• On: Operate</li> <li>• Off: Non-operation</li> </ul>
ENGINE START BY I-KEY	Engine start function mode can be changed to operation with this mode <ul style="list-style-type: none"> <li>• On: Operate</li> <li>• Off: Non-operation</li> </ul>
TRUNK/GLASS HATCH OPEN	<b>NOTE:</b> This item is displayed, but cannot be used
PANIC ALARM SET	Panic alarm button pressing time on Intelligent Key button can be selected from the following with this mode <ul style="list-style-type: none"> <li>• MODE 1: 0.5 sec</li> <li>• MODE 2: Non-operation</li> <li>• MODE 3: 1.5 sec</li> </ul>
TRUNK OPEN DELAY	<b>NOTE:</b> This item is displayed, but cannot be used
LO- BATT OF KEY FOB WARN	Intelligent Key low battery warning mode can be changed to operation with this mode <ul style="list-style-type: none"> <li>• On: Operate</li> <li>• Off: Non-operation</li> </ul>
ANTI KEY LOCK IN FUNCTI	Key reminder function mode can be changed to operation with this mode <ul style="list-style-type: none"> <li>• On: Operate</li> <li>• Off: Non-operation</li> </ul>
HAZARD ANSWER BACK	Hazard reminder function mode by door request switch and Intelligent Key button can be selected from the following with this mode <ul style="list-style-type: none"> <li>• Lock Only: Door lock operation only</li> <li>• Unlock Only: Door unlock operation only</li> <li>• Lock/Unlock: Lock and unlock operation</li> <li>• Off: Non-operation</li> </ul>
ANS BACK I-KEY LOCK	Buzzer reminder function (lock operation) mode by door request switch can be selected from the following with this mode <ul style="list-style-type: none"> <li>• Horn Chirp: Sound horn</li> <li>• Buzzer: Sound Intelligent Key warning buzzer</li> <li>• Off: Non-operation</li> </ul>
ANS BACK I-KEY UNLOCK	Buzzer reminder function (unlock operation) mode by door request switch can be changed to operation with this mode <ul style="list-style-type: none"> <li>• On: Operate</li> <li>• Off: Non-operation</li> </ul>
SHORT CRANKING OUTPUT	Starter motor can operate during the times below <ul style="list-style-type: none"> <li>• 70 msec</li> <li>• 100 msec</li> <li>• 200 msec</li> </ul>
CONFIRM KEY FOB ID	It can be checked whether Intelligent Key ID code is registered or not in this mode
AUTO LOCK SET	Auto door lock operation time can be changed in this mode <ul style="list-style-type: none"> <li>• MODE 1: OFF</li> <li>• MODE 2: 30 sec</li> <li>• MODE 3: 1 minute</li> <li>• MODE 4: 2 minutes</li> <li>• MODE 5: 3 minutes</li> <li>• MODE 6: 4 minutes</li> <li>• MODE 7: 5 minutes</li> </ul>



# DIAGNOSIS SYSTEM (BCM)

## [POWER DISTRIBUTION SYSTEM]

### < SYSTEM DESCRIPTION >

Monitor item	Description
HORN WITH KEYLESS LOCK	Horn reminder function mode by Intelligent Key button can be selected from the following with this mode <ul style="list-style-type: none"> <li>• On: Operate</li> <li>• Off: Non-operation</li> </ul>
PW DOWN SET	Unlock button pressing time on Intelligent Key button can be selected from the following with this mode <ul style="list-style-type: none"> <li>• MODE 1: 3 sec</li> <li>• MODE 2: Non-operation</li> <li>• MODE 3: 5 sec</li> </ul>

### SELF-DIAG RESULT

Refer to [BCS-63. "DTC Index"](#).

### DATA MONITOR

#### NOTE:

The following table includes information (items) inapplicable to this vehicle. For information (items) applicable to this vehicle, refer to CONSULT display items.

Monitor Item	Condition
REQ SW -DR	Indicates [On/Off] condition of door request switch (driver side)
REQ SW -AS	Indicates [On/Off] condition of door request switch (passenger side)
REQ SW -BD/TR	Indicates [On/Off] condition of back door request switch
PUSH SW	Indicates [On/Off] condition of push-button ignition switch
CLUTCH SW	<b>NOTE:</b> This item is displayed, but cannot be monitored
BRAKE SW 1	Indicates [On/Off]* condition of stop lamp switch power supply
BRAKE SW 2	Indicates [On/Off] condition of stop lamp switch
DETE/CANCL SW	Indicates [On/Off] condition of P position
SFT PN/N SW	Indicates [On/Off] condition of P or N position
S/L -LOCK	<b>NOTE:</b> This item is displayed, but cannot be monitored
S/L -UNLOCK	<b>NOTE:</b> This item is displayed, but cannot be monitored
S/L RELAY -F/B	<b>NOTE:</b> This item is displayed, but cannot be monitored
UNLK SEN -DR	Indicates [On/Off] condition of driver door UNLOCK status
PUSH SW -IPDM	Indicates [On/Off] condition of push-button ignition switch
IGN RLY1 -F/B	Indicates [On/Off] condition of ignition relay 1
DETE SW -IPDM	Indicates [On/Off] condition of P position
SFT PN -IPDM	Indicates [On/Off] condition of P or N position
SFT P -MET	Indicates [On/Off] condition of P position
SFT N -MET	Indicates [On/Off] condition of N position
ENGINE STATE	Indicates [Stop/Stall/Crank/Run] condition of engine states
S/L LOCK-IPDM	<b>NOTE:</b> This item is displayed, but cannot be monitored
S/L UNLK-IPDM	<b>NOTE:</b> This item is displayed, but cannot be monitored
S/L RELAY-REQ	<b>NOTE:</b> This item is displayed, but cannot be monitored
VEH SPEED 1	Display the vehicle speed signal received from combination meter by numerical value [km/h]
VEH SPEED 2	Display the vehicle speed signal received from ABS or VDC or TCM by numerical value [km/h]
DOOR STAT-DR	Indicates [LOCK/READY/UNLK] condition of unlock sensor

# DIAGNOSIS SYSTEM (BCM)

< SYSTEM DESCRIPTION >

[POWER DISTRIBUTION SYSTEM]

Monitor Item	Condition
DOOR STAT-AS	Indicates [LOCK/READY/UNLK] condition of passenger side door status
ID OK FLAG	Indicates [Set/Reset] condition of key ID
PRMT ENG STRT	Indicates [Set/Reset] condition of engine start possibility
PRMT RKE STRT	<b>NOTE:</b> This item is displayed, but cannot be monitored
TRNK/HAT MNTR	<b>NOTE:</b> This item is displayed, but cannot be monitored
RKE-LOCK	Indicates [On/Off] condition of LOCK signal from Intelligent Key
RKE-UNLOCK	Indicates [On/Off] condition of UNLOCK signal from Intelligent Key
RKE-TR/BD	<b>NOTE:</b> This item is displayed, but cannot be monitored
RKE-PANIC	Indicates [On/Off] condition of PANIC button of Intelligent Key
RKE-MODE CHG	Indicates [On/Off] condition of MODE CHANGE signal from Intelligent Key
RKE OPE COUN1	When remote keyless entry receiver receives the signal transmitted while operating on Intelligent Key, the numerical value start changing
RKE OPE COUN2	<b>NOTE:</b> This item is displayed, but cannot be monitored

\*: OFF is displayed when brake pedal is depressed while brake switch power supply is OFF.

## ACTIVE TEST

Test item	Description
BATTERY SAVER	This test is able to check interior room lamp operation <ul style="list-style-type: none"> <li>• On: Operate</li> <li>• Off: Non-operation</li> </ul>
OUTSIDE BUZZER	This test is able to check Intelligent Key warning buzzer operation <ul style="list-style-type: none"> <li>• On: Operate</li> <li>• Off: Non-operation</li> </ul>
INSIDE BUZZER	This test is able to check warning chime in combination meter operation <ul style="list-style-type: none"> <li>• Take Out: Take away warning chime sounds when CONSULT screen is touched</li> <li>• Key: Key warning chime sounds when CONSULT screen is touched</li> <li>• Knob: OFF position warning chime sounds when CONSULT screen is touched</li> <li>• Off: Non-operation</li> </ul>
INDICATOR	This test is able to check warning lamp operation <ul style="list-style-type: none"> <li>• KEY ON: "KEY" Warning lamp illuminates when CONSULT screen is touched</li> <li>• KEY IND: "KEY" Warning lamp blinks when CONSULT screen is touched</li> <li>• Off: Non-operation</li> </ul>
INT LAMP	This test is able to check interior room lamp operation <ul style="list-style-type: none"> <li>• On: Operate</li> <li>• Off: Non-operation</li> </ul>
LCD	This test is able to check meter display information <ul style="list-style-type: none"> <li>• Engine start information displays when "BP N" on CONSULT screen is touched</li> <li>• Engine start information displays when "BP I" on CONSULT screen is touched</li> <li>• Key ID warning displays when "ID NG" on CONSULT screen is touched</li> <li>• ROTAT: This item is displayed, but cannot be used.</li> <li>• P position warning displays when "SFT P" on CONSULT screen is touched</li> <li>• INSRT: This item is displayed, but cannot be monitored</li> <li>• BATT: This item is displayed, but cannot be monitored</li> <li>• Take away through window warning displays when "NO KY" on CONSULT screen is touched</li> <li>• Take away warning display when "OUTKEY" on CONSULT screen is touched</li> <li>• OFF position warning display when "LK WN" on CONSULT screen is touched</li> </ul>
FLASHER	This test is able to check hazard warning lamp operation <ul style="list-style-type: none"> <li>• LH: LH side hazard warning lamps operate</li> <li>• RH: RH side hazard warning lamps operate</li> <li>• Off: Non-operation</li> </ul>

# DIAGNOSIS SYSTEM (BCM)

< SYSTEM DESCRIPTION >

[POWER DISTRIBUTION SYSTEM]

Test item	Description	
P RANGE	This test is able to check CVT shift selector power supply <ul style="list-style-type: none"> <li>• On: Operate</li> <li>• Off: Non-operation</li> </ul>	A
ENGINE SW ILLUMI	This test is able to check push-button ignition switch illumination operation <ul style="list-style-type: none"> <li>• On: Operate</li> <li>• Off: Non-operation</li> </ul>	B
LOCK INDICATOR	This test is able to check LOCK indicator (push-button ignition switch) operation <ul style="list-style-type: none"> <li>• On: Operate</li> <li>• Off: Non-operation</li> </ul>	C
ACC INDICATOR	This test is able to check ACC indicator (push-button ignition switch) operation <ul style="list-style-type: none"> <li>• On: Operate</li> <li>• Off: Non-operation</li> </ul>	D
IGNITION ON IND	This test is able to check ON indicator (push-button ignition switch) operation <ul style="list-style-type: none"> <li>• On: Operate</li> <li>• Off: Non-operation</li> </ul>	E
HORN	This test is able to check horn operation <ul style="list-style-type: none"> <li>• On: Operate</li> <li>• Off: Non-operation</li> </ul>	F
TRUNK/BACK DOOR	<b>NOTE:</b> This item is displayed, but cannot be used	G
POWER SLIDE DOOR	This test is able to check automatic sliding door operation <ul style="list-style-type: none"> <li>• RR PSD ON: Auto open/close operate</li> <li>• RL PSD ON: Auto open/close operate</li> </ul>	H

I  
J  
K  
L  
N  
O  
P

PCS

# ECU DIAGNOSIS INFORMATION

## BCM

### List of ECU Reference

INFOID:000000008380898

ECU	Reference
BCM	<a href="#">BCS-40. "Reference Value"</a>
	<a href="#">BCS-62. "Fail-safe"</a>
	<a href="#">BCS-62. "DTC Inspection Priority Chart"</a>
	<a href="#">BCS-63. "DTC Index"</a>

# POWER DISTRIBUTION SYSTEM

< WIRING DIAGRAM >

[POWER DISTRIBUTION SYSTEM]

## WIRING DIAGRAM

### POWER DISTRIBUTION SYSTEM

#### Wiring Diagram

INFOID:000000008380899

For connector terminal arrangements, harness layouts, and alphabets in a  (option abbreviation; if not described in wiring diagram), refer to [GI-12. "Connector Information"](#).

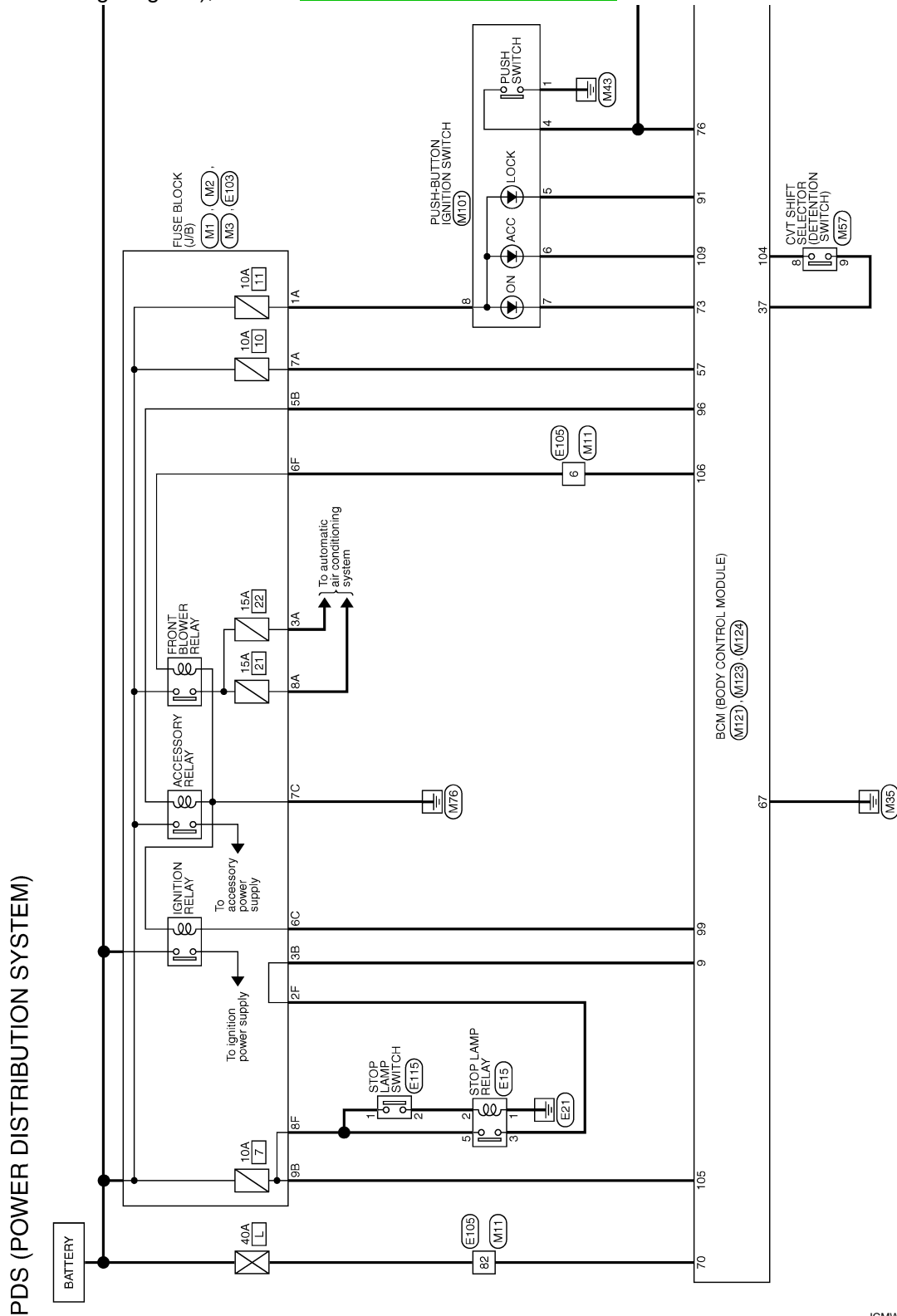

# POWER DISTRIBUTION SYSTEM

< WIRING DIAGRAM >

[POWER DISTRIBUTION SYSTEM]

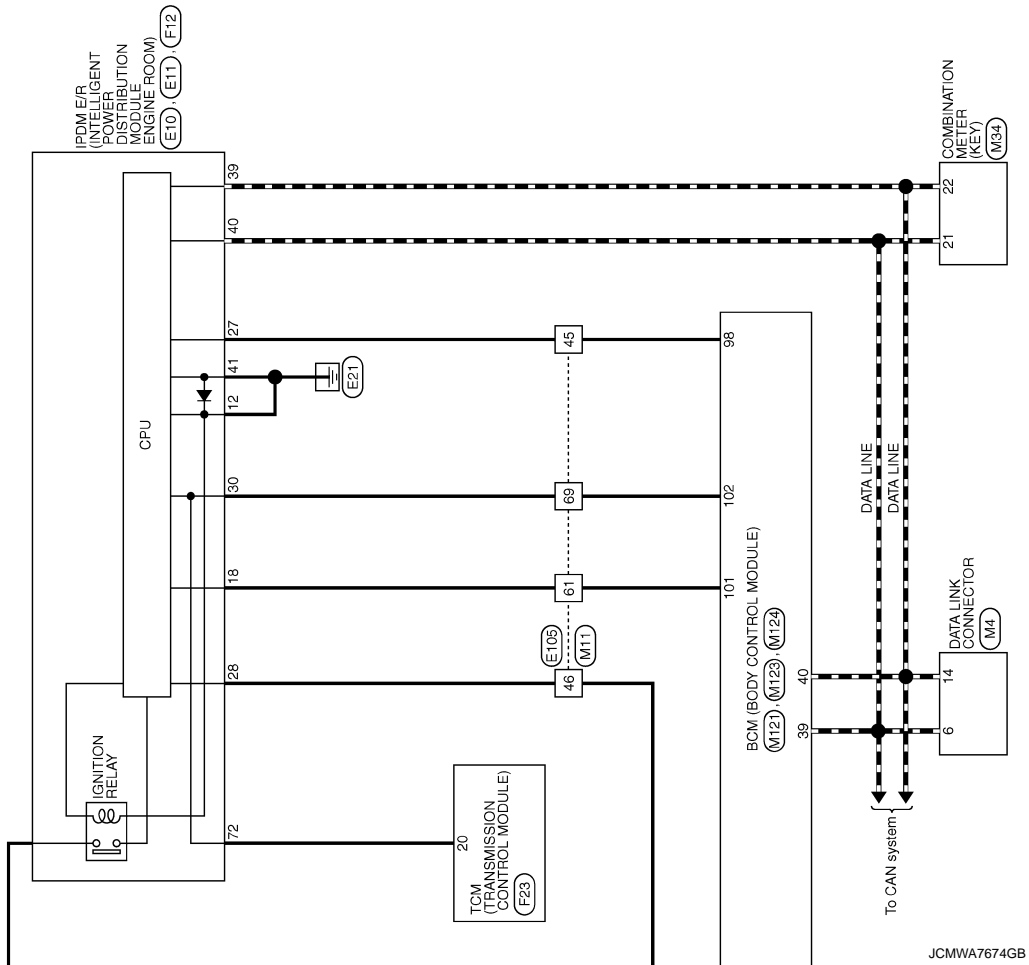

JCMWA7674GB

# DIAGNOSIS AND REPAIR WORK FLOW

< BASIC INSPECTION >

[POWER DISTRIBUTION SYSTEM]

## BASIC INSPECTION

### DIAGNOSIS AND REPAIR WORK FLOW

Work Flow

INFOID:000000008380900

OVERALL SEQUENCE

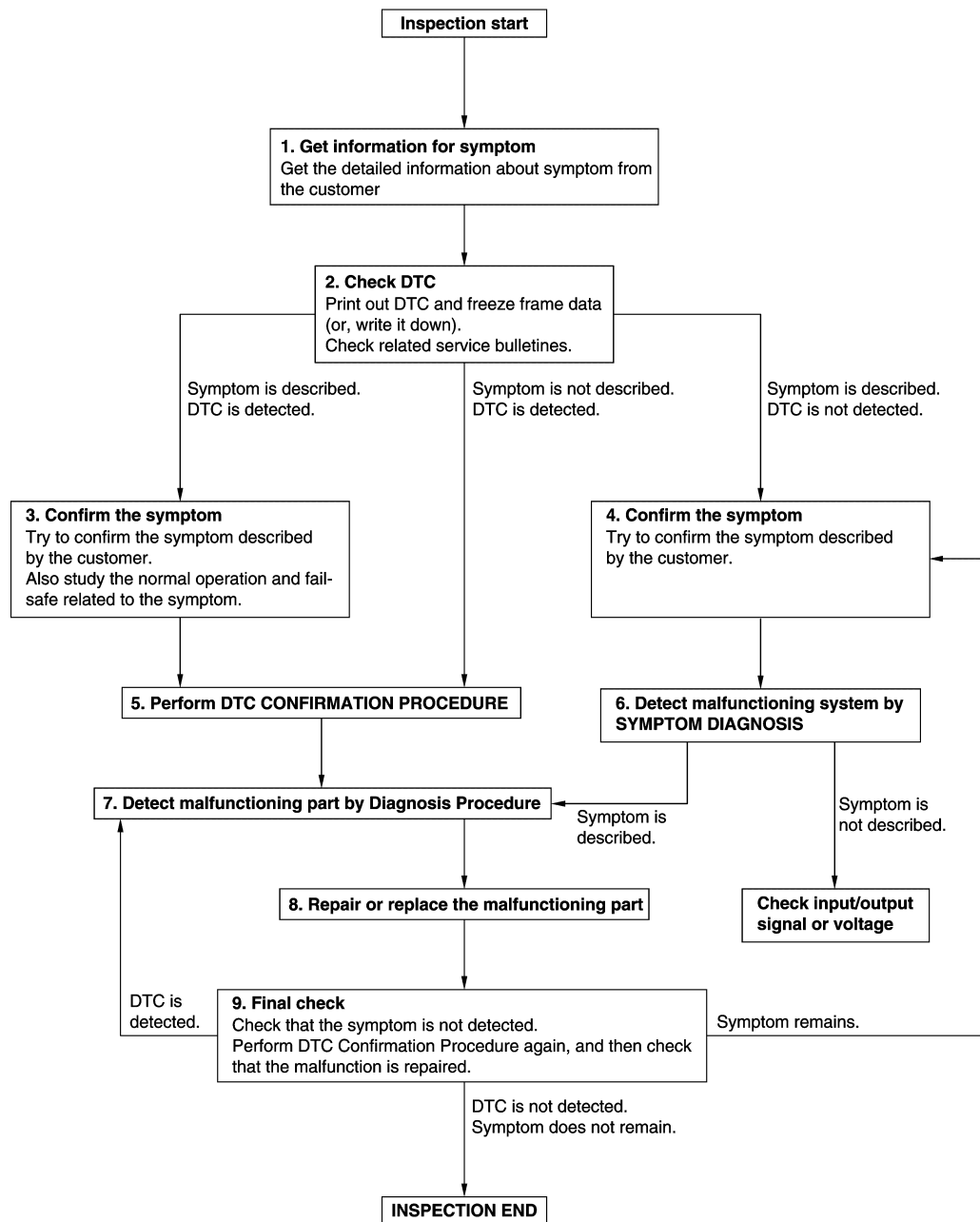

DETAILED FLOW

JMKIA8652GB

# DIAGNOSIS AND REPAIR WORK FLOW

[POWER DISTRIBUTION SYSTEM]

< BASIC INSPECTION >

---

## 1. GET INFORMATION FOR SYMPTOM

---

1. Get detailed information from the customer about the symptom (the condition and the environment when the incident/malfunction occurs).
2. Check operation condition of the function that is malfunctioning.

>> GO TO 2.

---

## 2. CHECK DTC

---

1. Check DTC.
2. Perform the following procedure if DTC is detected.
  - Record DTC and freeze frame data (Print them out using CONSULT.)
  - Erase DTC.
  - Study the relationship between the cause detected by DTC and the symptom described by the customer.
3. Check related service bulletins for information.

Are any symptoms described and any DTC detected?

Symptom is described, DTC is detected>>GO TO 3.

Symptom is described, DTC is not detected>>GO TO 4.

Symptom is not described, DTC is detected>>GO TO 5.

---

## 3. CONFIRM THE SYMPTOM

---

Try to confirm the symptom described by the customer.

Also study the normal operation and fail-safe related to the symptom.

Verify relation between the symptom and the condition when the symptom is detected.

>> GO TO 5.

---

## 4. CONFIRM THE SYMPTOM

---

Try to confirm the symptom described by the customer.

Verify relation between the symptom and the condition when the symptom is detected.

>> GO TO 6.

---

## 5. PERFORM DTC CONFIRMATION PROCEDURE

---

Perform DTC CONFIRMATION PROCEDURE for the detected DTC, and then check that DTC is detected again. At this time, always connect CONSULT to the vehicle, and check self diagnostic results in real time.

If two or more DTCs are detected, refer to [BCS-62. "DTC Inspection Priority Chart"](#) and determine trouble diagnosis order.

**NOTE:**

- Freeze frame data is useful if the DTC is not detected.
- Perform Component Function Check if DTC CONFIRMATION PROCEDURE is not included on Service Manual. This simplified check procedure is an effective alternative though DTC cannot be detected during this check.

If the result of Component Function Check is NG, it is the same as the detection of DTC by DTC CONFIRMATION PROCEDURE.

Is DTC detected?

YES >> GO TO 7.

NO >> Check according to [GI-42. "Intermittent Incident"](#).

---

## 6. DETECT MALFUNCTIONING SYSTEM BY SYMPTOM DIAGNOSIS

---

Detect malfunctioning system according to SYMPTOM DIAGNOSIS based on the confirmed symptom in step 4, and determine the trouble diagnosis order based on possible causes and symptom.

Is the symptom described?

YES >> GO TO 7.

NO >> Monitor input data from related sensors or check voltage of related module terminals using CONSULT.

---

## 7. DETECT MALFUNCTIONING PART BY DIAGNOSTIC PROCEDURE

---



# DIAGNOSIS AND REPAIR WORK FLOW

## [POWER DISTRIBUTION SYSTEM]

### < BASIC INSPECTION >

Inspect according to Diagnostic Procedure of the system.

Is malfunctioning part detected?

YES >> GO TO 8.

NO >> Check according to [GI-42. "Intermittent Incident"](#).

### 8. REPAIR OR REPLACE THE MALFUNCTIONING PART

1. Repair or replace the malfunctioning part.
2. Reconnect parts or connectors disconnected during Diagnostic Procedure again after repair and replacement.
3. Check DTC. If DTC is detected, erase it.

>> GO TO 9.

### 9. FINAL CHECK

When DTC is detected in step 2, perform DTC CONFIRMATION PROCEDURE again, and then check that the malfunction is repaired securely.

When symptom is described by the customer, refer to confirmed symptom in step 3 or 4, and check that the symptom is not detected.

Is DTC detected and does symptom remain?

YES-1 >> DTC is detected: GO TO 7.

YES-2 >> Symptom remains: GO TO 4.

NO >> Before returning the vehicle to the customer, always erase DTC.

A  
B  
C  
D  
E  
F  
G  
H  
I  
J  
K  
L  
N  
O  
P

PCS

# B2614 ACC RELAY CIRCUIT

< DTC/CIRCUIT DIAGNOSIS >

[POWER DISTRIBUTION SYSTEM]

## DTC/CIRCUIT DIAGNOSIS

### B2614 ACC RELAY CIRCUIT

#### DTC Logic

INFOID:000000008380901

#### DTC DETECTION LOGIC

DTC No.	Trouble diagnosis name	DTC detecting condition	Possible cause
B2614	BCM	The following status are compared, and it does not agree for 1 second or more. <ul style="list-style-type: none"> <li>State of accessory relay control judgment in BCM</li> <li>State of accessory relay control signal</li> </ul>	<ul style="list-style-type: none"> <li>Harness or connectors (Accessory relay control signal circuit)</li> <li>BCM</li> <li>Accessory relay</li> </ul>

#### DTC CONFIRMATION PROCEDURE

##### 1. PERFORM DTC CONFIRMATION PROCEDURE

- Turn ignition switch to ACC, and wait for 1 second or more.
- Check "Self-diagnosis result" of BCM with CONSULT.

##### Is DTC detected?

- YES >> Go to [PCS-50. "Diagnosis Procedure"](#).  
 NO >> INSPECTION END

#### Diagnosis Procedure

INFOID:000000008380902

##### 1. CHECK ACCESSORY RELAY CONTROL SIGNAL

Check voltage between BCM harness connector and ground.

(+)		(-)	Condition	Voltage (V) (Approx.)	
BCM					
Connector	Terminal				
M124	96	Ground	Ignition switch	OFF	0 - 0.5
				ACC or ON	9 - 16

##### Is the inspection result normal?

- YES >> Replace BCM. Refer to [BCS-86. "Removal and Installation"](#).  
 NO >> GO TO 2.

##### 2. CHECK ACCESSORY RELAY CONTROL SIGNAL CIRCUIT

- Turn ignition switch OFF.
- Disconnect BCM connector and accessory relay.
- Check continuity between BCM harness connector and accessory relay harness connector.

BCM		Accessory relay	Continuity
Connector	Terminal	Terminal	
M124	96	Coil upstream side	Existed

- Check continuity between BCM harness connector and ground.

BCM		Ground	Continuity
Connector	Terminal		
M124	96		Not existed

##### Is the inspection result normal?

- YES >> GO TO 3.  
 NO >> Repair or replace harness.

# B2614 ACC RELAY CIRCUIT

[POWER DISTRIBUTION SYSTEM]

< DTC/CIRCUIT DIAGNOSIS >

## 3. CHECK ACCESSORY RELAY

Refer to [PCS-51. "Component Inspection"](#).

Is the inspection result normal?

- YES >> Replace BCM. Refer to [BCS-86. "Removal and Installation"](#).
- NO >> Replace accessory relay.

## Component Inspection

INFOID:000000008380903

### 1. CHECK ACCESSORY RELAY

1. Turn ignition switch OFF.
2. Remove accessory relay.
3. Check the continuity between accessory relay terminals.

Terminals	Condition	Continuity
3 and 5	12 V direct current supply between terminals 1 and 2	Existed
	No current supply	Not existed

Is the inspection result normal?

- YES >> INSPECTION END
- NO >> Replace accessory relay

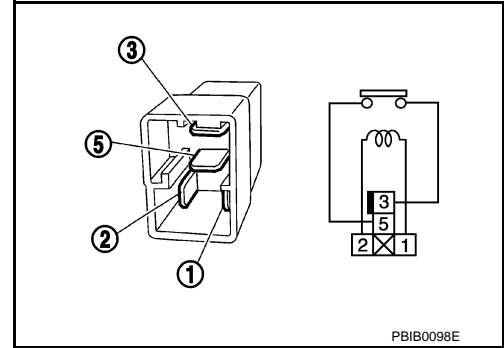

PBIB0098E

A  
B  
C  
D  
E  
F  
G  
H  
I  
J  
K  
L  
N  
O  
P

PCS

# B2615 BLOWER RELAY CIRCUIT

< DTC/CIRCUIT DIAGNOSIS >

[POWER DISTRIBUTION SYSTEM]

## B2615 BLOWER RELAY CIRCUIT

### DTC Logic

INFOID:000000008380904

### DTC DETECTION LOGIC

DTC No.	Trouble diagnosis name	DTC detecting condition	Possible cause
B2616	BCM	The following status are compared, and it does not agree for 1 second or more. <ul style="list-style-type: none"><li>• State of blower relay control judgment in BCM</li><li>• State of blower relay control signal</li></ul>	<ul style="list-style-type: none"><li>• Harness or connectors (Blower relay control signal circuit)</li><li>• BCM</li><li>• Blower relay</li></ul>

### DTC CONFIRMATION PROCEDURE

#### 1. PERFORM DTC CONFIRMATION PROCEDURE

1. Turn ignition switch ON, and wait for 1 second or more.
2. Check "Self-diagnosis result" with CONSULT.

#### Is DTC detected?

- YES >> Go to [PCS-54. "Diagnosis Procedure"](#).  
NO >> INSPECTION END

### Diagnosis Procedure

INFOID:000000008380905

#### 1. CHECK BLOWER RELAY CONTROL SIGNAL

Check voltage between BCM harness connector and ground.

(+)		(-)	Condition	Voltage (V) (Approx.)	
BCM					
Connector	Terminal				
M124	106	Ground	Ignition switch	OFF or ACC	0 - 0.5
				ON	9 - 16

#### Is the inspection result normal?

- YES >> Replace BCM. Refer to [BCS-86. "Removal and Installation"](#).  
NO >> GO TO 2.

#### 2. CHECK BLOWER RELAY CONTROL SIGNAL CIRCUIT

1. Turn ignition switch OFF.
2. Disconnect BCM connector and blower relay.
3. Check continuity between BCM harness connector and blower relay harness connector.

BCM		Blower relay		Continuity
Connector	Terminal	Terminal		
M124	106	Coil upstream side		Existed

4. Check continuity between BCM harness connector and ground.

BCM		Ground	Continuity
Connector	Terminal		
M124	106		Not existed

#### Is the inspection result normal?

- YES >> GO TO 3.  
NO >> Repair or replace harness.

#### 3. CHECK BLOWER RELAY

Refer to [PCS-51. "Component Inspection"](#).

# B2615 BLOWER RELAY CIRCUIT

[POWER DISTRIBUTION SYSTEM]

< DTC/CIRCUIT DIAGNOSIS >

Is the inspection result normal?

YES >> Replace BCM. Refer to [BCS-86, "Removal and Installation"](#).

NO >> Replace blower relay.

## Component Inspection

INFOID:000000008380906

### 1. CHECK BLOWER RELAY

1. Turn blower switch OFF.
2. Remove blower relay.
3. Check the continuity between blower relay terminals.

Terminals	Condition	Continuity
3 and 5	12 V direct current supply between terminals 1 and 2	Existed
	No current supply	Not existed

Is the inspection result normal?

YES >> INSPECTION END

NO >> Replace blower relay

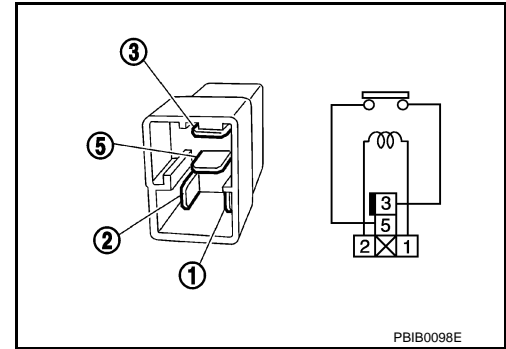

A  
B  
C  
D  
E  
F  
G  
H  
I  
J  
K  
L  
N  
O  
P

PCS

# B2616 IGNITION RELAY CIRCUIT

< DTC/CIRCUIT DIAGNOSIS >

[POWER DISTRIBUTION SYSTEM]

## B2616 IGNITION RELAY CIRCUIT

### DTC Logic

INFOID:000000008380907

### DTC DETECTION LOGIC

DTC No.	Trouble diagnosis name	DTC detecting condition	Possible cause
B2616	BCM	The following status are compared, and it does not agree for 1 second or more. <ul style="list-style-type: none"> <li>State of ignition relay (fuse block) control judgment in BCM</li> <li>State of ignition relay (fuse block) control signal</li> </ul>	<ul style="list-style-type: none"> <li>Harness or connectors [Ignition relay (fuse block) control signal circuit]</li> <li>BCM</li> <li>Ignition relay (fuse block)</li> </ul>

### DTC CONFIRMATION PROCEDURE

#### 1. PERFORM DTC CONFIRMATION PROCEDURE

- Turn ignition switch ON, and wait for 1 second or more.
- Check "Self-diagnosis result" with CONSULT.

#### Is DTC detected?

- YES >> Go to [PCS-54. "Diagnosis Procedure"](#).  
 NO >> INSPECTION END

### Diagnosis Procedure

INFOID:000000008380908

#### 1. CHECK IGNITION RELAY (FUSE BLOCK) CONTROL SIGNAL

Check voltage between BCM harness connector and ground.

(+)		(-)	Condition	Voltage (V) (Approx.)	
BCM					
Connector	Terminal				
M124	99	Ground	Ignition switch	OFF or ACC	0 - 0.5
				ON	9 - 16

#### Is the inspection result normal?

- YES >> Replace BCM. Refer to [BCS-86. "Removal and Installation"](#).  
 NO >> GO TO 2.

#### 2. CHECK IGNITION RELAY (FUSE BLOCK) CONTROL SIGNAL CIRCUIT

- Turn ignition switch OFF.
- Disconnect BCM connector and ignition relay (fuse block).
- Check continuity between BCM harness connector and ignition relay (fuse block) harness connector.

BCM		Ignition relay (fuse block)	Continuity
Connector	Terminal	Terminal	
M124	99	Coil upstream side	Existed

- Check continuity between BCM harness connector and ground.

BCM		Ground	Continuity
Connector	Terminal		
M124	99		Not existed

#### Is the inspection result normal?

- YES >> GO TO 3.  
 NO >> Repair or replace harness.

#### 3. CHECK IGNITION RELAY (FUSE BLOCK)

# B2616 IGNITION RELAY CIRCUIT

[POWER DISTRIBUTION SYSTEM]

< DTC/CIRCUIT DIAGNOSIS >

Refer to [PCS-51, "Component Inspection"](#).

Is the inspection result normal?

- YES >> Replace BCM. Refer to [BCS-86, "Removal and Installation"](#).
- NO >> Replace ignition relay (fuse block).

## Component Inspection

INFOID:000000008380909

### 1. CHECK IGNITION RELAY

1. Turn ignition switch OFF.
2. Remove ignition relay.
3. Check the continuity between ignition relay terminals.

Terminals	Condition	Continuity
3 and 5	12 V direct current supply between terminals 1 and 2	Existed
	No current supply	Not existed

Is the inspection result normal?

- YES >> INSPECTION END
- NO >> Replace ignition relay

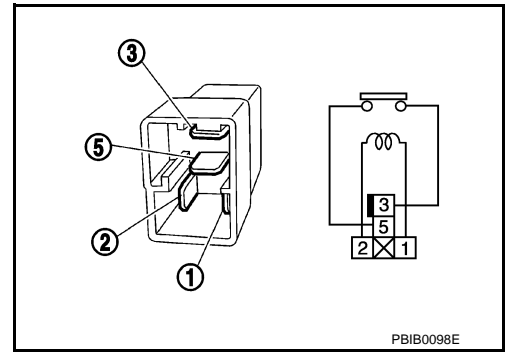

A  
B  
C  
D  
E  
F  
G  
H  
I  
J  
K  
L  
N  
O  
P

PCS

# B2618 BCM

< DTC/CIRCUIT DIAGNOSIS >

[POWER DISTRIBUTION SYSTEM]

## B2618 BCM

### DTC Logic

INFOID:000000008380910

### DTC DETECTION LOGIC

DTC No.	Trouble diagnosis name	DTC detecting condition	Possible cause
B2618	BCM	The following status are compared, and it does not agree for 1 second or more. <ul style="list-style-type: none"> <li>State of ignition relay (IPDM E/R) control judgment in BCM</li> <li>State of ignition relay (IPDM E/R) control signal</li> </ul>	<ul style="list-style-type: none"> <li>Harness or connectors [Ignition relay (IPDM E/R) control signal circuit]</li> <li>BCM</li> <li>IPDM E/R</li> </ul>

### DTC CONFIRMATION PROCEDURE

#### 1. PERFORM DTC CONFIRMATION PROCEDURE

- Turn ignition switch ON, and wait for 1 second or more.
- Check "Self-diagnosis result" of BCM with CONSULT.

#### Is DTC detected?

- YES >> Go to [PCS-56. "Diagnosis Procedure"](#).  
 NO >> INSPECTION END

### Diagnosis Procedure

INFOID:000000008380911

#### 1. CHECK IGNITION RELAY (IPDM E/R) CONTROL SIGNAL

Check voltage between BCM harness connector and ground.

(+)		(-)	Condition	Voltage (V) (Approx.)	
BCM					
Connector	Terminal				
M124	98	Ground	Ignition switch	OFF or ACC	9 - 16
				ON	0 - 0.5

#### Is the inspection result normal?

- YES >> Replace BCM. Refer to [BCS-86. "Removal and Installation"](#).  
 NO >> GO TO 2.

#### 2. CHECK IGNITION RELAY (IPDM E/R) CONTROL SIGNAL CIRCUIT

- Turn ignition switch OFF.
- Disconnect BCM connector and IPDM E/R.
- Check continuity between BCM harness connector and IPDM E/R harness connector.

BCM		IPDM E/R		Continuity
Connector	Terminal	Connector	Terminal	
M124	98	E10	27	Existed

- Check continuity between BCM harness connector and ground.

BCM		Ground	Continuity
Connector	Terminal		
M124	98		Not existed

#### Is the inspection result normal?

- YES >> GO TO 3.  
 NO >> Repair or replace harness.

#### 3. CHECK VOLTAGE OF IGNITION RELAY (IPDM E/R) CONTROL SIGNAL CIRCUIT (IPDM E/R SIDE)



# B2618 BCM

## [POWER DISTRIBUTION SYSTEM]

### < DTC/CIRCUIT DIAGNOSIS >

1. Connect IPDM E/R connector.
2. Check voltage between IPDM E/R harness connector and ground.

(+)		(-)	Condition		Voltage (V) (Approx.)
IPDM E/R					
Connector	Terminal				
E10	27	Ground	Ignition switch	OFF	9 - 16

### Is the inspection result normal?

- YES >> Replace BCM. Refer to [BCS-86, "Removal and Installation"](#).
- NO >> Replace IPDM E/R.

A  
B  
C  
D  
E  
F  
G  
H  
I  
J  
K  
L

PCS

N  
O  
P

# B261A PUSH-BUTTON IGNITION SWITCH

< DTC/CIRCUIT DIAGNOSIS >

[POWER DISTRIBUTION SYSTEM]

## B261A PUSH-BUTTON IGNITION SWITCH

### DTC Logic

INFOID:000000008380912

### DTC DETECTION LOGIC

DTC No.	Trouble diagnosis name	DTC detecting condition	Possible cause
B261A	PUSH-BTN IGN SW	The following signal status that BCM receives are compared, and it does not agree for 1 second or more. <ul style="list-style-type: none"> <li>Push-button Ignition switch (push switch) signal</li> <li>Push-button Ignition switch (push switch) status signal (CAN)</li> </ul>	<ul style="list-style-type: none"> <li>Harness or connectors [Push-button Ignition switch (push switch) circuit]</li> <li>BCM</li> <li>IPDM E/R</li> </ul>

### DTC CONFIRMATION PROCEDURE

#### 1. PERFORM DTC CONFIRMATION PROCEDURE

- Press push-button ignition switch (push switch) under the following conditions, and wait for 1 second or more.
  - Shift position is in the P position
  - Do not depress brake pedal
- Check "Self-diagnosis result" of BCM with CONSULT.

#### Is DTC detected?

- YES >> Go to [PCS-58, "Diagnosis Procedure"](#).  
NO >> INSPECTION END

### Diagnosis Procedure

INFOID:000000008380913

#### 1. CHECK PUSH-BUTTON IGNITION SWITCH (PUSH SWITCH) OUTPUT SIGNAL

- Disconnect push-button ignition switch connector and IPDM E/R connector.
- Check voltage between push-button ignition switch harness connector and ground.

(+)		(-)	Voltage (V) (Approx.)
Push-button Ignition switch			
Connector	Terminal		
M101	4	Ground	9 - 16

#### Is the inspection result normal?

- YES >> GO TO 3.  
NO >> GO TO 2.

#### 2. CHECK PUSH-BUTTON IGNITION SWITCH CIRCUIT (BCM)

- Disconnect BCM connector.
- Check continuity between BCM harness connector and push-button ignition switch harness connector.

BCM		Push-button Ignition switch		Continuity
Connector	Terminal	Connector	Terminal	
M124	76	M101	4	Existed

- Check continuity between push-button ignition switch harness connector and ground.

Push-button Ignition switch		Ground	Continuity
Connector	Terminal		
M101	4		Not existed

#### Is the inspection result normal?

- YES >> Replace BCM. Refer to [BCS-86, "Removal and Installation"](#).

# B261A PUSH-BUTTON IGNITION SWITCH

[POWER DISTRIBUTION SYSTEM]

< DTC/CIRCUIT DIAGNOSIS >

NO >> Repair or replace harness.

### 3.CHECK PUSH-BUTTON IGNITION SWITCH (PUSH SWITCH) OUTPUT SIGNAL (IPDM E/R)

Check voltage between IPDM E/R harness connector and ground.

(+)		(-)	Voltage (V) (Approx.)
IPDM E/R			
Connector	Terminal	Ground	9 - 16
E10	28		

Is the inspection result normal?

YES >> Replace IPDM E/R.

NO >> GO TO 4.

### 4.CHECK PUSH-BUTTON IGNITION SWITCH (PUSH SWITCH) CIRCUIT (IPDM E/R)

1. Disconnect BCM connector.
2. Check continuity between IPDM E/R harness connector and push-button ignition switch harness connector.

IPDM E/R		Push-button Ignition switch		Continuity
Connector	Terminal	Connector	Terminal	
E10	28	M101	4	Existed

3. Check continuity between push-button ignition switch harness connector and ground.

Push-button Ignition switch		Ground	Continuity
Connector	Terminal		
M101	4		Not existed

Is the inspection result normal?

YES >> GO TO 5.

NO >> Repair or replace harness.

### 5.CHECK INTERMITTENT INCIDENT

Refer to [GI-42, "Intermittent Incident"](#).

>> INSPECTION END

PCS

# B26F1 IGNITION RELAY

< DTC/CIRCUIT DIAGNOSIS >

[POWER DISTRIBUTION SYSTEM]

## B26F1 IGNITION RELAY

### DTC Logic

INFOID:000000008380914

### DTC DETECTION LOGIC

DTC No.	Trouble diagnosis name	DTC detecting condition	Possible cause
B26F1	IGN RELAY OFF	BCM transmits the ignition relay control signal (ON: 0 V) or ignition switch ON signal (ON) (CAN), but does not receives ignition switch ON signal (ON) (CAN) from IPDM E/R.	<ul style="list-style-type: none"><li>• Harness or connectors (Ignition relay circuit is open)</li><li>• BCM</li><li>• IPDM E/R</li></ul>

### DTC CONFIRMATION PROCEDURE

#### 1. PERFORM DTC CONFIRMATION PROCEDURE

1. Turn ignition switch ON, and wait for 2 seconds or more.
2. Check "Self-diagnosis result" with CONSULT.

#### Is DTC detected?

- YES >> Go to [PCS-60. "Diagnosis Procedure"](#).  
NO >> INSPECTION END

### Diagnosis Procedure

INFOID:000000008380915

#### 1. CHECK IPDM E/R SELF-DIAGNOSTIC RESULT

1. Turn ignition switch ON.
2. Erase the DTC of IPDM E/R.
3. Turn ignition switch OFF.
4. Turn ignition switch ON and check the DTC again.

#### Is DTC detected?

- YES >> Repair or replace the malfunctioning part. Refer to [PCS-24. "DTC Index"](#).  
NO >> GO TO 2.

#### 2. CHECK IGNITION RELAY (IPDM E/R) CONTROL SIGNAL

Check voltage between BCM harness connector and ground.

(+)		(-)	Condition		Voltage (V) (Approx.)
BCM					
Connector	Terminal	Ground	Ignition switch	ON	0 - 0.5
M124	98				

#### Is the inspection result normal?

- YES >> GO TO 3.  
NO >> Replace BCM. Refer to [BCS-86. "Removal and Installation"](#).

#### 3. CHECK IGNITION RELAY (IPDM E/R) CONTROL SIGNAL CIRCUIT

1. Turn ignition switch OFF.
2. Disconnect BCM and IPDM connectors.
3. Check continuity between BCM harness connector and IPDM E/R harness connector.

BCM		IPDM E/R		Continuity
Connector	Terminal	Connector	Terminal	
M124	98	E10	27	Existed

#### Is the inspection result normal?

- YES >> Replace IPDM E/R.  
NO >> Repair or replace harness.

# B26F2 IGNITION RELAY

< DTC/CIRCUIT DIAGNOSIS >

[POWER DISTRIBUTION SYSTEM]

## B26F2 IGNITION RELAY

### DTC Logic

INFOID:000000008380916

### DTC DETECTION LOGIC

DTC No.	Trouble diagnosis name	DTC detecting condition	Possible cause
B26F2	IGN RELAY ON	BCM transmits the ignition relay control signal (OFF: 12 V) or ignition switch ON signal (OFF) (CAN), but does not receives ignition switch ON signal (OFF) (CAN) from IPDM E/R.	<ul style="list-style-type: none"> <li>• Harness or connectors (Ignition relay circuit is short)</li> <li>• BCM</li> <li>• IPDM E/R</li> </ul>

### DTC CONFIRMATION PROCEDURE

#### 1. PERFORM DTC CONFIRMATION PROCEDURE

1. Turn ignition switch ON, and wait for 2 seconds or more.
2. Check "Self-diagnosis result" with CONSULT.

#### Is DTC detected?

- YES >> Go to [PCS-61, "Diagnosis Procedure"](#).  
 NO >> INSPECTION END

### Diagnosis Procedure

INFOID:000000008380917

#### 1. CHECK IPDM E/R SELF-DIAGNOSTIC RESULT

1. Turn ignition switch ON.
2. Erase the DTC of IPDM E/R.
3. Turn ignition switch OFF.
4. Turn ignition switch ON and check the DTC again.

#### Is DTC detected?

- YES >> Repair or replace the malfunctioning part. Refer to [PCS-24, "DTC Index"](#).  
 NO >> GO TO 2.

#### 2. CHECK IGNITION RELAY (IPDM E/R) CONTROL SIGNAL

1. Turn ignition switch OFF.
2. Check voltage between IPDM E/R harness connector and ground.

(+)		(-)	Condition		Voltage (V) (Approx.)
IPDM E/R					
Connector	Terminal	Ground	Ignition switch	OFF or ACC	6 - 16
E10	27				

PCS

#### Is the inspection result normal?

- YES >> Replace IPDM E/R.  
 NO >> GO TO 3.

#### 3. CHECK IGNITION RELAY (IPDM E/R) CONTROL SIGNAL CIRCUIT - 1

1. Turn ignition switch OFF.
2. Disconnect BCM and IPDM E/R connectors.
3. Check continuity between IPDM E/R harness connector and ground.

IPDM E/R		Ground	Continuity
Connector	Terminal		
E10	27		Not existed

#### Is the inspection result normal?

- YES >> GO TO 4.  
 NO >> Repair or replace harness.

## B26F2 IGNITION RELAY

< DTC/CIRCUIT DIAGNOSIS >

[POWER DISTRIBUTION SYSTEM]

### 4. CHECK IGNITION RELAY (IPDM E/R) CONTROL SIGNAL CIRCUIT - 2

1. Connect IPDM E/R connectors.
2. Check voltage between IPDM E/R harness connector and ground.

(+)		(-)	Condition		Voltage (V) (Approx.)
IPDM E/R					
Connector	Terminal				
E10	27	Ground	Ignition switch	OFF or ACC	6 - 16

Is the inspection result normal?

- YES >> Replace BCM. Refer to [BCS-86. "Removal and Installation"](#).  
NO >> Replace IPDM E/R.

B26F6 BCM

DTC Logic

INFOID:000000008380918

DTC DETECTION LOGIC

NOTE:

- If DTC B26F6 is displayed with DTC U1000, first perform the trouble diagnosis for DTC U1000. Refer to [BCS-75. "DTC Logic"](#).
- If DTC B26F6 is displayed with DTC U1010, first perform the trouble diagnosis for DTC U1010. Refer to [BCS-76. "DTC Logic"](#).

DTC No.	Trouble diagnosis name	DTC detecting condition	Possible cause
B26F6	BCM	Ignition switch ON signal (CAN) (ON) is not transmitted from IPDM E/R, when BCM turns ignition relay ON [Transmit ignition switch ON signal (CAN) (ON)].	BCM

DTC CONFIRMATION PROCEDURE

1. PERFORM DTC CONFIRMATION PROCEDURE

1. Turn ignition switch ON, and wait for 0.5 seconds or more.
2. Check "Self-diagnosis result" of BCM with CONSULT.

Is DTC detected?

- YES >> Go to [PCS-63. "Diagnosis Procedure"](#).
- NO >> INSPECTION END

Diagnosis Procedure

INFOID:000000008380919

1. INSPECTION START

1. Turn ignition switch ON.
2. Select "Self-diagnosis result" of BCM with CONSULT.
3. Touch "ERASE".
4. Perform DTC Confirmation Procedure.  
See [PCS-63. "DTC Logic"](#).

Is DTC detected?

- YES >> Replace BCM. Refer to [BCS-86. "Removal and Installation"](#)
- NO >> INSPECTION END

A  
B  
C  
D  
E  
F  
G  
H  
I  
J  
K  
L

PCS

# PUSH-BUTTON IGNITION SWITCH

< DTC/CIRCUIT DIAGNOSIS >

[POWER DISTRIBUTION SYSTEM]

## PUSH-BUTTON IGNITION SWITCH

### Component Function Check

INFOID:000000008380920

#### 1.CHECK FUNCTION

1. Select "PUSH SW" in "Data Monitor" mode with CONSULT.
2. Check the push-button ignition switch signal under the following conditions.

Test item	Condition	Status
PUSH SW	Push-button ignition switch is pressed	ON
	Push-button ignition switch is not pressed	OFF

Is the indication normal?

- YES >> INSPECTION END.  
NO >> Go to [PCS-64, "Diagnosis Procedure"](#).

### Diagnosis Procedure

INFOID:000000008380921

#### 1.CHECK PUSH-BUTTON IGNITION SWITCH OUTPUT SIGNAL 1

1. Turn ignition switch OFF.
2. Disconnect push-button ignition switch connector and IPDM E/R connector.
3. Check voltage between push-button ignition switch harness connector and ground.

(+)		(-)	Voltage (V) (Approx.)
Connector	Terminal		
M101	4	Ground	9 -16

Is the inspection result normal?

- YES >> GO TO 3.  
NO >> GO TO 2.

#### 2.CHECK PUSH-BUTTON IGNITION SWITCH CIRCUIT 1

1. Disconnect BCM connector.
2. Check continuity between BCM harness connector and push-button ignition switch harness connector.

BCM		Push-button ignition switch		Continuity
Connector	Terminal	Connector	Terminal	
M124	76	M101	4	Existed

3. Check continuity between BCM harness connector and ground.

BCM		Ground	Continuity
Connector	Terminal		
M124	76		Not existed

Is the inspection result normal?

- YES >> Replace BCM. Refer to [BCS-86, "Removal and Installation"](#).  
NO >> Repair or replace harness.

#### 3.CHECK PUSH-BUTTON IGNITION SWITCH OUTPUT SIGNAL 2

Check voltage between IPDM E/R harness connector and ground.



# PUSH-BUTTON IGNITION SWITCH

< DTC/CIRCUIT DIAGNOSIS >

[POWER DISTRIBUTION SYSTEM]

(+)		(-)	Voltage (V) (Approx.)
IPDM E/R			
Connector	Terminal		
E10	28	Ground	9 - 16

Is the inspection result normal?

YES >> GO TO 5.

NO >> GO TO 4.

## 4.CHECK PUSH-BUTTON IGNITION SWITCH CIRCUIT 2

1. Disconnect BCM connector.
2. Check continuity between IPDM E/R harness connector and push-button ignition switch harness connector.

IPDM E/R		Push-button ignition switch		Continuity
Connector	Terminal	Connector	Terminal	
E10	28	M101	4	Existed

3. Check continuity between IPDM E/R harness connector and ground.

IPDM E/R		Ground	Continuity
Connector	Terminal		
E10	28		Not existed

Is the inspection result normal?

YES >> Replace IPDM E/R.

NO >> Repair or replace harness.

## 5.CHECK PUSH-BUTTON IGNITION SWITCH GROUND CIRCUIT

Check continuity between push-button ignition switch harness connector and ground.

Push-button ignition switch		Ground	Continuity
Connector	Terminal		
M101	1		Existed

Is the inspection result normal?

YES >> GO TO 6.

NO >> Repair or replace harness.

## 6.CHECK PUSH-BUTTON IGNITION SWITCH

Refer to [PCS-65, "Component Inspection"](#).

Is the inspection result normal?

YES >> GO TO 7.

NO >> Replace push-button ignition switch.

## 7.CHECK INTERMITTENT INCIDENT

Refer to [GI-42, "Intermittent Incident"](#).

>> INSPECTION END

## Component Inspection

INFOID:000000008380922

## 1.CHECK PUSH-BUTTON IGNITION SWITCH

1. Turn ignition switch OFF.
2. Disconnect push-button ignition switch connector.
3. Check continuity between push-button ignition switch terminals.

# PUSH-BUTTON IGNITION SWITCH

< DTC/CIRCUIT DIAGNOSIS >

[POWER DISTRIBUTION SYSTEM]

Push-button ignition switch		Condition	Continuity
Terminal			
4	1	Pressed	Existed
		Not pressed	Not existed

Is the inspection result normal?

YES >> INSPECTION END

NO >> Replace push-button ignition switch.

# PUSH-BUTTON IGNITION SWITCH POSITION INDICATOR

< DTC/CIRCUIT DIAGNOSIS >

[POWER DISTRIBUTION SYSTEM]

## PUSH-BUTTON IGNITION SWITCH POSITION INDICATOR

### Description

INFOID:000000008380923

Push-button ignition switch changes the power supply position.  
BCM maintains the power supply position status.  
BCM changes the power supply position with the operation of the push-button ignition switch.

### Component Function Check

INFOID:000000008380924

#### 1.CHECK FUNCTION

Check push-button ignition switch ("LOCK INDICATOR", "ACC INDICATOR" and "IGNITION ON IND") in Active Test of BCM with CONSULT.

Test item		Description	
LOCK INDICATOR ACC INDICATOR IGNITION ON IND	ON	Position indicator	Illuminates
	OFF		Does not illuminate

Is the inspection result normal?

- YES >> INSPECTION END.  
NO >> Refer to [PCS-67, "Diagnosis Procedure"](#).

### Diagnosis Procedure

INFOID:000000008380925

#### 1.CHECK PUSH-BUTTON IGNITION SWITCH INPUT SIGNAL

- Turn ignition switch OFF.
- Disconnect push-button ignition switch connector.
- Check voltage between push-button ignition switch harness connector and ground.

(+)		(-)	Voltage (V) (Approx.)
Push-button ignition switch			
Connector	Terminal	Ground	Battery voltage
M101	8		

Is the inspection normal?

- YES >> GO TO 2.  
NO-1 >> Check 10 A fuse [No.10, located in fuse block (J/B)].  
NO-2 >> Check harness for open or short between push-button ignition switch and fuse.

#### 2.CHECK BCM INPUT

- Connect push-button ignition switch connector.
- Disconnect BCM connector.
- Check voltage between BCM connector and ground.

(+)		(-)	Voltage (V) (Approx.)
BCM			
Connector	Terminal	Ground	Battery voltage
M124	73		
	91		
	109		

Is the inspection normal?

- YES >> Replace BCM. Refer to [BCS-86, "Removal and Installation"](#).  
NO >> GO TO 3.

#### 3.CHECK PUSH-BUTTON IGNITION SWITCH CIRCUIT

- Disconnect push-button ignition switch connector.

A  
B  
C  
D  
E  
F  
G  
H  
I  
J  
K  
L  
N  
O  
P

PCS

# PUSH-BUTTON IGNITION SWITCH POSITION INDICATOR

< DTC/CIRCUIT DIAGNOSIS >

[POWER DISTRIBUTION SYSTEM]

2. Check continuity between BCM harness connector and push-button ignition switch harness connector.

Indicator	BCM		Push-button ignition switch		Continuity
	Connector	Terminal	Connector	Terminal	
LOCK	M124	91	M101	5	Existed
ACC		109		6	
ON		73		7	

3. Check continuity between BCM harness connector and ground.

Indicator	BCM		Ground	Continuity
	Connector	Terminal		
LOCK	M124	91	Ground	Not existed
ACC		109		
ON		73		

Is the inspection normal?

YES >> Replace push-button ignition switch.

NO >> Repair or replace harness.

# PUSH-BUTTON IGNITION SWITCH DOES NOT OPERATE

< SYMPTOM DIAGNOSIS >

[POWER DISTRIBUTION SYSTEM]

## SYMPTOM DIAGNOSIS

### PUSH-BUTTON IGNITION SWITCH DOES NOT OPERATE

#### Description

INFOID:000000008380926

Check that vehicle is under the condition shown in “Conditions of vehicle” before starting diagnosis, and check each symptom.

#### NOTE:

The engine start function, door lock function, power distribution system, and NATS-IVIS/NVIS in the Intelligent Key system are closely related to each other regarding control. The vehicle security function can operate only when the door lock and power distribution system are operating normally.

#### Conditions of Vehicle (Operating Conditions)

- “ENGINE START BY I-KEY” in “WORK SUPPORT” is ON when setting on CONSULT.
- One or more of Intelligent Keys with registered Intelligent Key ID is in the vehicle.

#### Diagnosis Procedure

INFOID:000000008380927

#### 1.PERFORM WORK SUPPORT

Perform “INSIDE ANT DIAGNOSIS” on Work Support of “INTELLIGENT KEY”.

Refer to [DLK-95, "INTELLIGENT KEY : CONSULT Function \(BCM - INTELLIGENT KEY\)"](#).

>> GO TO 2.

#### 2.PERFORM SELF-DIAGNOSIS RESULT

Perform Self-Diagnosis Result of “BCM”.

#### Is DTC detected?

YES >> Refer to [BCS-63, "DTC Index"](#).

NO >> GO TO 3.

#### 3.CHECK PUSH-BUTTON IGNITION SWITCH

Check push-button ignition switch.

Refer to [PCS-64, "Component Function Check"](#).

#### Is the operation normal?

YES >> GO TO 4.

NO >> Repair or replace malfunctioning parts.

#### 4.CONFIRM THE OPERATION

Confirm the operation again.

#### Is the inspection normal?

YES >> Check intermittent incident. Refer to [GI-42, "Intermittent Incident"](#).

NO >> GO TO 1.

A  
B  
C  
D  
E  
F  
G  
H  
I  
J  
K  
L  
N  
O  
P

PCS

# PUSH-BUTTON IGNITION SWITCH POSITION INDICATOR DOES NOT ILLUMINATE

< SYMPTOM DIAGNOSIS >

[POWER DISTRIBUTION SYSTEM]

## PUSH-BUTTON IGNITION SWITCH POSITION INDICATOR DOES NOT ILLUMINATE

### Description

INFOID:000000008380928

- Before performing the diagnosis in the following table, check "Work Flow". Refer to [PCS-47, "Work Flow"](#).
- Check that vehicle is under the condition shown in "Conditions of vehicle" before starting diagnosis, and check each symptom.

### Conditions of Vehicle (Operating Conditions)

- "ENGINE START BY I-KEY" in "WORK SUPPORT" is ON when setting on CONSULT.
- One or more of Intelligent Keys with registered Intelligent Key ID is in the vehicle.

### Diagnosis Procedure

INFOID:000000008380929

#### 1. CHECK PUSH-BUTTON IGNITION SWITCH INDICATOR

Check push-button ignition switch indicator.

Refer to [PCS-67, "Component Function Check"](#).

Is the inspection result normal?

YES >> GO TO 2.

NO >> Repair or replace the malfunctioning parts.

#### 2. CONFIRM THE OPERATION

Confirm the operation again.

Is the result normal?

YES >> Check intermittent incident. Refer to [GI-42, "Intermittent Incident"](#).

NO >> GO TO 1.