

SECTION **RSU**
 REAR SUSPENSION

A
 B
 C
 D
 E
 F
 G
 H
 I
 J
 K
 L
 M
 N
 O
 P

RSU

CONTENTS

PRECAUTION	2	Removal and Installation	10	F
PRECAUTIONS	2	Disassembly and Assembly	11	
Precautions for Suspension	2	Inspection	11	
PREPARATION	3	Disposal	12	G
PREPARATION	3	RADIUS ROD	13	
Commercial Service Tools	3	Exploded View	13	
SYMPTOM DIAGNOSIS	4	Removal and Installation	13	H
NOISE, VIBRATION AND HARSHNESS		Inspection	13	
(NVH) TROUBLESHOOTING	4	FRONT LOWER LINK	15	I
NVH Troubleshooting Chart	4	Exploded View	15	
PERIODIC MAINTENANCE	5	Removal and Installation	15	
REAR SUSPENSION ASSEMBLY	5	Inspection	15	J
Inspection	5	SUSPENSION ARM	17	
WHEEL ALIGNMENT	6	Exploded View	17	
Inspection	6	Removal and Installation	17	K
Adjustment	6	Inspection	17	
REMOVAL AND INSTALLATION	8	REAR SUSPENSION ASSEMBLY	19	L
REAR LOWER LINK & COIL SPRING	8	Exploded View	19	
Exploded View	8	Removal and Installation	19	
Removal and Installation	8	Inspection	20	M
Inspection	9	SERVICE DATA AND SPECIFICATIONS		
REAR SHOCK ABSORBER	10	(SDS)	21	N
Exploded View	10	SERVICE DATA AND SPECIFICATIONS		
		(SDS)	21	O
		Wheel Alignment	21	
		Ball Joint	21	
		Wheelarch Height	21	P

PRECAUTIONS

< PRECAUTION >

PRECAUTION

PRECAUTIONS

Precautions for Suspension

INFOID:000000008380644

- When installing rubber bushings, the final tightening must be carried out under unladen conditions with tires on ground. Spilled oil might shorten the life of rubber bushings. Be sure to wipe off any spilled oil.
- Unladen conditions mean that fuel, engine coolant and lubricant are full. Spare tire, jack, hand tools and mats are in designated positions.
- After servicing suspension parts, be sure to check wheel alignment.
- Self-lock nuts are not reusable. Always use new ones when installing. Since new self-lock nuts are pre-oiled, tighten as they are.

PREPARATION

< PREPARATION >

PREPARATION

PREPARATION

Commercial Service Tools

INFOID:000000008380645

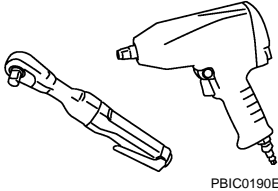
Tool name	Description
<p data-bbox="159 415 267 441">Power tool</p>  <p data-bbox="885 630 954 646">PBIC0190E</p>	<p data-bbox="1057 415 1307 441">Loosening bolts and nuts</p>

A

B

C

D

RSU

F

G

H

I

J

K

L

M

N

O

P

NOISE, VIBRATION AND HARSHNESS (NVH) TROUBLESHOOTING

< SYMPTOM DIAGNOSIS >

SYMPTOM DIAGNOSIS

NOISE, VIBRATION AND HARSHNESS (NVH) TROUBLESHOOTING

NVH Troubleshooting Chart

INFOID:000000008380646

Use chart below to find the cause of the symptom. If necessary, repair or replace these parts.

Symptom		Possible cause and SUSPECTED PARTS											
		Improper installation, looseness	Shock absorber deformation, damage or deflection	Bushing or mounting deterioration	Parts interference	Spring fatigue	Suspension looseness	Incorrect wheel alignment	REAR AXLE AND REAR SUSPENSION	TIRE	ROAD WHEEL	BRAKE	
Symptom	REAR SUSPENSION	Noise	x	x	x	x	x	x		x	x	x	x
	Shake	x	x	x	x		x		x	x	x	x	
	Vibration	x	x	x	x	x			x	x			
	Shimmy	x	x	x	x			x	x	x	x	x	
	Judder	x	x	x					x	x	x	x	
	Poor quality ride or handling	x	x	x	x	x		x	x	x	x		
Reference		RSU-8, RSU-10, RSU-13, RSU-15, RSU-17, RSU-19	RSU-9	—	—	—	RSU-8, RSU-10, RSU-13, RSU-15, RSU-17, RSU-19	RSU-6	NVH in RAX and RSU sections.	NVH in WT section.	NVH in WT section.	NVH in BR section.	

x: Applicable

REAR SUSPENSION ASSEMBLY

< PERIODIC MAINTENANCE >

PERIODIC MAINTENANCE

REAR SUSPENSION ASSEMBLY

Inspection

INFOID:000000008380647

COMPONENT PART

Check the mounting conditions (looseness, backlash) of each component and component conditions (wear, damage) are normal.

Ball Joint Axial End Play

1. Set front wheels in a straight-ahead position.
2. Move axle side of suspension arm in the axial direction by hand. Check there is no end play.

Axial end play : Refer to [RSU-21, "Ball Joint"](#).

CAUTION:

- Never depress brake pedal when measuring.
- Never perform with tires on level ground.
- Be careful not to damage ball joint boot. Never damage the installation position by applying excessive force.

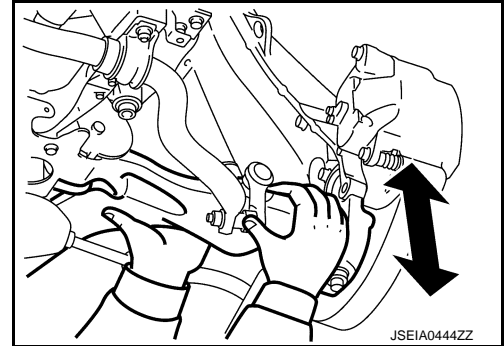

SHOCK ABSORBER

Check for oil leakage and damage. Replace it if necessary.

A
B
C
D
RSU
F
G
H
I
J
K
L
M
N
O
P

WHEEL ALIGNMENT

< PERIODIC MAINTENANCE >

WHEEL ALIGNMENT

Inspection

INFOID:000000008380648

DESCRIPTION

Measure wheel alignment under unladen conditions.

NOTE:

"Unladen conditions" means that fuel, engine coolant, and lubricant are full. Spare tire, jack, hand tools and mats are in designated positions.

PRELIMINARY CHECK

Check the following:

- Tires for improper air pressure and wear. Refer to [WT-48, "Tire Air Pressure"](#).
- Road wheels for runout.
- Wheel bearing axial end play. Refer to [RAX-4, "Inspection"](#).
- Ball joint axial end play of suspension arm. Refer to [RSU-5, "Inspection"](#).
- Shock absorber operation.
- Each mounting point of axle and suspension for looseness and deformation.
- Each of front lower link, rear lower link, radius rod, rear suspension member, suspension arm, and shock absorber for cracks, deformation, and other damage.
- Vehicle height (posture).

GENERAL INFORMATION AND RECOMMENDATIONS

- A four-wheel thrust alignment should be performed.
- This type of alignment is recommended for any NISSAN/INFINITI vehicle.
- The four-wheel "thrust" process helps ensure that the vehicle is properly aligned and the steering wheel is centered.
- The alignment rack itself should be capable of accepting any NISSAN/INFINITI vehicle.
- The rack should be checked to ensure that it is level.
- Make sure the machine is properly calibrated.
- Your alignment equipment should be regularly calibrated in order to give correct information.
- Check with the manufacturer of your specific equipment for their recommended Service/Calibration Schedule.

ALIGNMENT PROCESS

IMPORTANT:

Use only the alignment specifications listed in this Service Manual.

- When displaying the alignment settings, many alignment machines use "indicators": (Green/red, plus or minus, Go/No Go). **Never use these indicators.**
- The alignment specifications programmed into your machine that operate these indicators may not be correct.
- This may result in an ERROR.
- Most camera-type alignment machines are equipped with both "Rolling Compensation" method and optional "Jacking Compensation" method to "compensate" the alignment targets or head units. "Rolling Compensation" is the preferred method.
- If using the "Rolling Compensation" method, after installing the alignment targets or head units, push or pull on the rear wheel to move the vehicle. **Do not push or pull on the vehicle body.**
- If using the "Jacking Compensation" method, after installing the alignment targets or head units, raise the vehicle and rotate the wheels 1/2 turn both ways.

NOTE:

- Do not use the "Rolling Compensation" method if you are using sensor-type alignment equipment.
- Follow all instructions for the alignment machine you're using for more information.

Adjustment

INFOID:000000008380649

CAMBER

WHEEL ALIGNMENT

< PERIODIC MAINTENANCE >

- If camber exceeds the standard value, adjust with adjusting bolt (1) in front lower link (2).

Camber: Refer to [RSU-21, "Wheel Alignment"](#).

CAUTION:

- **When tightening the nut firmly and checking the torque, use a wrench to prevent the turning of the bolt.**
- **After adjusting camber, be sure to check toe-in.**
- If camber is not still within the specification, inspect and replace any damaged or worn suspension parts.

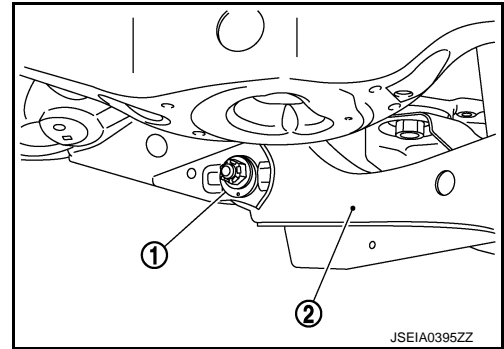

TOE-IN

- If toe-in exceeds the standard value, adjust with adjusting bolt (1) in rear lower link (2).

Toe-In: Refer to [RSU-21, "Wheel Alignment"](#).

CAUTION:

- **Be sure to adjust equally on right and left side with adjusting bolt.**
- **When tightening the nut firmly and checking the torque, use a wrench to prevent the turning of the bolt.**
- If toe-in is not still within the specification, inspect and replace any damaged or worn suspension parts.
- After toe-in adjustment, adjust neutral position of steering angle sensor. Refer to [BRC-44, "Work Procedure"](#).

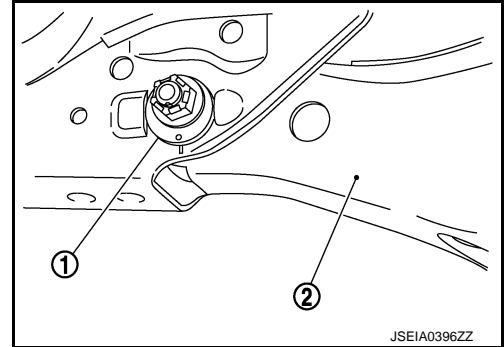

A
B
C
D
RSU
F
G
H
I
J
K
L
M
N
O
P

REAR LOWER LINK & COIL SPRING

< REMOVAL AND INSTALLATION >

REMOVAL AND INSTALLATION

REAR LOWER LINK & COIL SPRING

Exploded View

INFOID:000000008380650

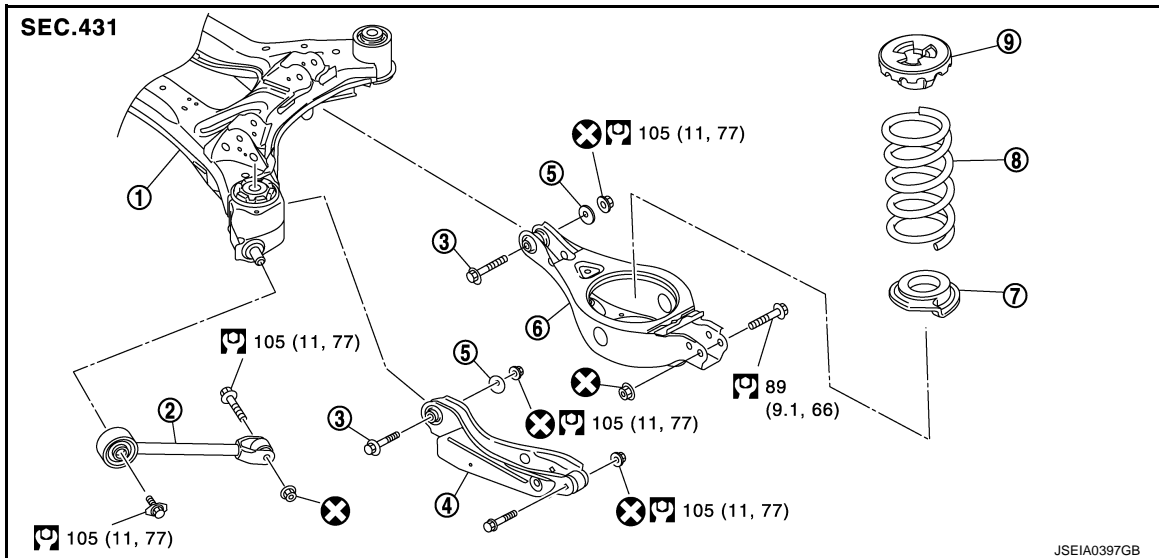

- | | | |
|---------------------------|-------------------|--------------------|
| 1. Rear suspension member | 2. Radius rod | 3. Adjusting bolt |
| 4. Front lower link | 5. Eccentric disk | 6. Rear lower link |
| 7. Rubber seat | 8. Coil spring | 9. Upper seat |

: N·m (kg·m, ft·lb)

: Always replace after every disassembly.

Removal and Installation

INFOID:000000008380651

REMOVAL

1. Remove tires with power tool. Refer to [WT-43, "Exploded View"](#).
2. Set suitable jack under rear lower link.
CAUTION:
 - At this step, the jack must be set only for supporting the removal procedure. For details on jacking up the vehicle, refer to [GI-29, "Garage Jack and Safety Stand and 2-Pole Lift"](#).
 - Never damage the rear lower link with a jack.
 - Check the stable condition when using a jack.
3. Loosen rear lower link adjusting bolt and nut from rear suspension member, and then remove rear lower link mounting bolt and nut from axle housing with power tool.
4. Slowly lower jack, then remove upper seat, coil spring, and rubber seat from rear lower link.
CAUTION:
Operate while checking that jack supporting status is stable.
5. Remove rear lower link.
6. Perform inspection after removal. Refer to [RSU-9, "Inspection"](#).

INSTALLATION

Note the following, and install in the reverse order of removal.

- Install adjusting bolt so that the graduation marks on adjusting bolt are positioned downward.

REAR LOWER LINK & COIL SPRING

< REMOVAL AND INSTALLATION >

- When installing upper seat (1), align protrusion (B) on upper seat inside to tabs (A) of vehicle side bracket (2).

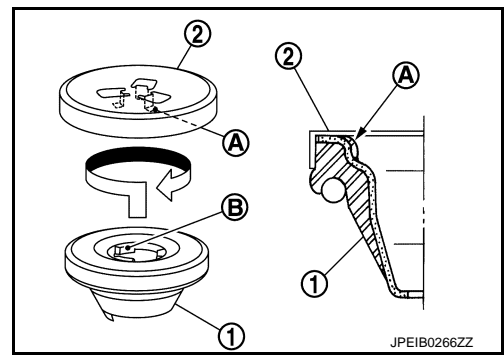

- Fit rubber seat (1) to step (A) of rear lower link (2).

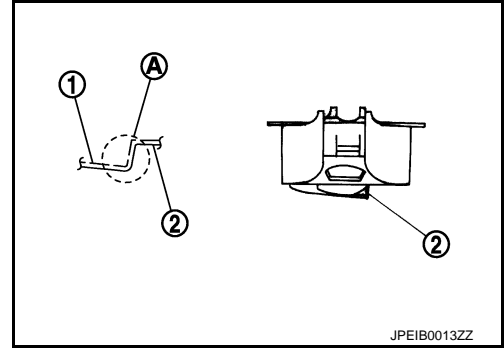

- Fit the bottom end of coil spring to the step of rubber seat.
- CAUTION:**
Be careful with the vertical direction of the coil spring.

↶ : Upper side

- Perform final tightening of fixing parts at the vehicle installation position (rubber bushing), under unladen conditions with tires on level ground.
- Perform inspection after installation. Refer to [RSU-9. "Inspection"](#).

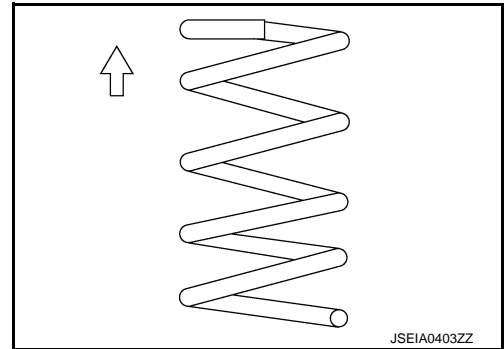

INFOID:000000008380652

Inspection

INSPECTION AFTER REMOVAL

Check rear lower link, rubber seat, upper seat, and coil spring for deformation, crack, and damage. Replace it if necessary.

INSPECTION AFTER INSTALLATION

Check wheel alignment. Refer to [RSU-6. "Inspection"](#).

REAR SHOCK ABSORBER

< REMOVAL AND INSTALLATION >

REAR SHOCK ABSORBER

Exploded View

INFOID:000000008380653

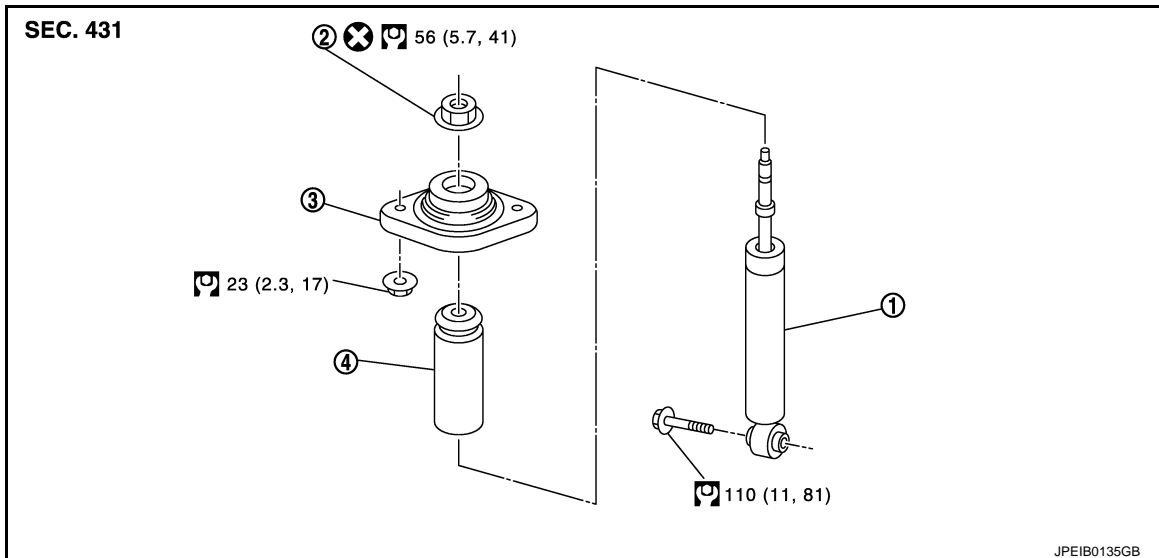

1. Shock absorber
2. Piston rod lock nut
3. Mounting bracket
4. Bound bumper

: N·m (kg-m, ft-lb)

: Always replace after every disassembly.

Removal and Installation

INFOID:000000008380654

REMOVAL

1. Remove tires with power tool. Refer to [WT-43, "Exploded View"](#).
2. Set jack under axle housing.
CAUTION:
 - At this step, the jack must be set only for supporting the removal procedure. For details on jacking up the vehicle, refer to [GI-29, "Garage Jack and Safety Stand and 2-Pole Lift"](#).
 - Never damage the axle housing with a jack.
 - Check the stable condition when using a jack.
3. Separate shock absorber mounting bolt from front lower link.
4. Slowly lower jack, then remove shock absorber from front lower link.
CAUTION:
Operate while checking that jack supporting status is stable.
5. Remove mounting bracket mounting nuts (), and remove shock absorber assembly.

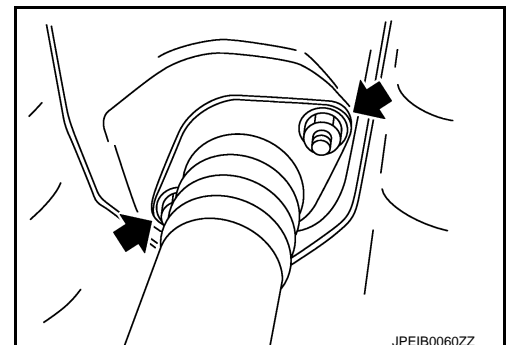

INSTALLATION

Note the following, and install in the reverse order of removal.

REAR SHOCK ABSORBER

< REMOVAL AND INSTALLATION >

- Perform final tightening of fixing parts at the vehicle installation position (rubber bushing), under unladen conditions with tires on level ground.
- Perform inspection after installation. Refer to [RSU-11, "Inspection"](#).
- After replacing the shock absorber, always follow the disposal procedure to discard the shock absorber. Refer to [RSU-12, "Disposal"](#).

Disassembly and Assembly

INFOID:000000008380655

DISASSEMBLY

CAUTION:

Never damage shock absorber piston rod when removing components from shock absorber.

1. Wrap a shop cloth around lower side of shock absorber and fix it with a vise.

CAUTION:

Never set the cylindrical part of shock absorber with a vise.

2. Secure the piston rod tip (A) so that piston rod does not turn, and remove piston rod lock nut (1).
3. Remove mounting bracket and bound bumper from shock absorber.
4. Perform inspection after disassembly. Refer to [RSU-11, "Inspection"](#).

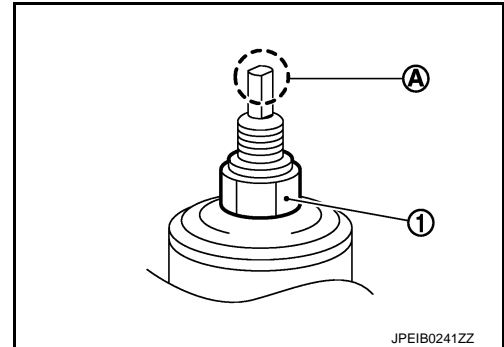

ASSEMBLY

Note the following, and install in the reverse order of removal.

- Secure the piston rod tip (A) so that piston rod does not turn, then tighten the piston rod lock nut (1) to the specified torque.

CAUTION:

Never reuse piston rod lock nut.

- Never damage shock absorber piston rod when installing components from shock absorber.
- Perform inspection after assembly. Refer to [RSU-11, "Inspection"](#).

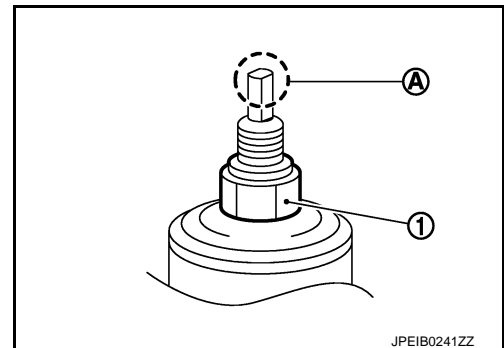

Inspection

INFOID:000000008380656

INSPECTION AFTER DISASSEMBLY

Mounting bracket

Check for cracks and damage. Replace it if necessary.

Bound Bumper

Check for cracks and damage. Replace it if necessary.

Shock Absorber

Check the following items, and replace the part if necessary.

- Shock absorber for deformation, cracks, and other damage.
- Piston rod for damage, uneven wear, and distortion.
- Oil leakage

INSPECTION AFTER ASSEMBLY

Make sure piston rod on shock absorber is not damaged when attaching components to shock absorber.

INSPECTION AFTER INSTALLATION

Check wheel alignment. Refer to [RSU-6, "Inspection"](#).

A
B
C
D
E
F
G
H
I
J
K
L
M
N
O
P

RSU

REAR SHOCK ABSORBER

< REMOVAL AND INSTALLATION >

Disposal

INFOID:000000008380657

1. Set shock absorber horizontally to the ground with the piston rod fully extracted.
2. Drill 2 – 3 mm (0.08 – 0.12 in) hole at the position (●) from top as shown in the figure to release gas gradually.

CAUTION:

- Wear eye protection (safety glasses).
- Wear gloves.
- Be careful with metal chips or oil blown out by the compressed gas.

NOTE:

- Drill vertically in this direction show by arrow.
- Directly to the outer tube avoiding brackets.
- The gas is clear, colorless, odorless, and harmless.

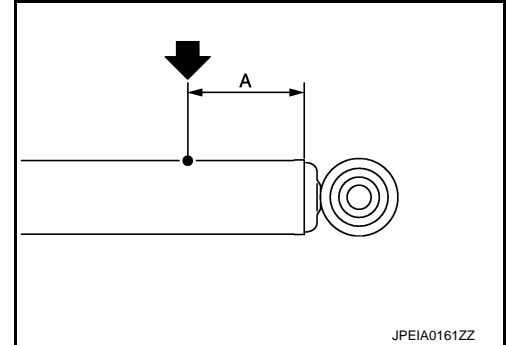

A : 20 – 30 mm (0.79 – 1.18 in)

3. Position the drilled hole downward and drain oil by moving the piston rod several times.

CAUTION:

Dispose of drained oil according to the law and local regulations.

RADIUS ROD

< REMOVAL AND INSTALLATION >

RADIUS ROD

Exploded View

INFOID:000000008380658

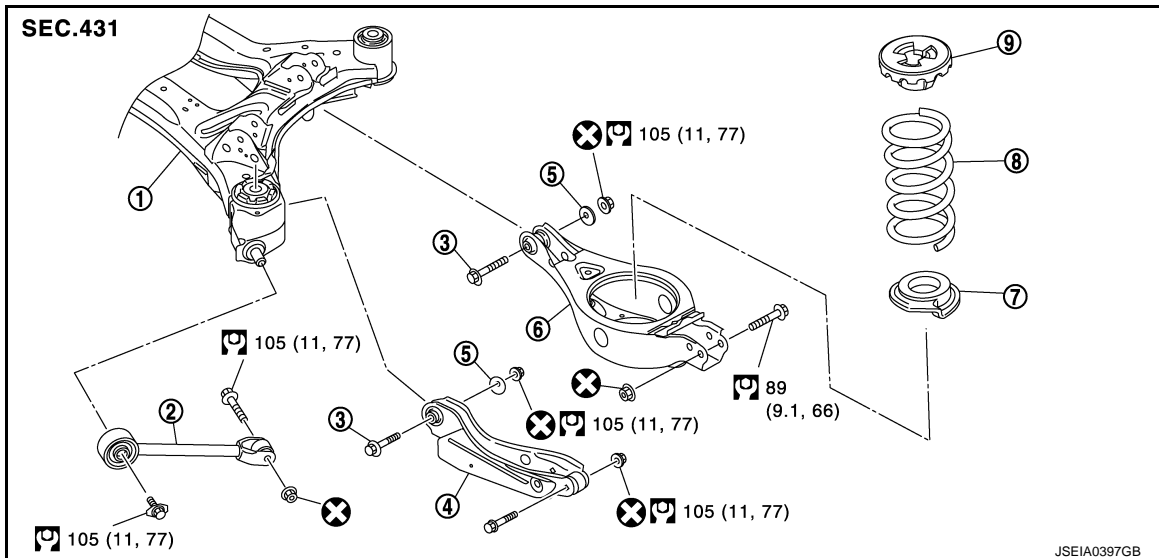

- | | | |
|---------------------------|-------------------|--------------------|
| 1. Rear suspension member | 2. Radius rod | 3. Adjusting bolt |
| 4. Front lower link | 5. Eccentric disk | 6. Rear lower link |
| 7. Rubber seat | 8. Coil spring | 9. Upper seat |

: N·m (kg-m, ft-lb)

: Always replace after every disassembly.

Removal and Installation

INFOID:000000008380659

REMOVAL

1. Remove tire with power tool. Refer to [WT-43, "Exploded View"](#).
2. Remove wheel sensor and sensor harness. Refer to [BRC-115, "REAR WHEEL SENSOR : Removal and Installation"](#).
3. Remove rear lower link and coil spring. Refer to [RSU-8, "Removal and Installation"](#).
4. Separate shock absorber from front lower link. Refer to [RSU-10, "Removal and Installation"](#).
5. Separate front lower link from axle housing. Refer to [RSU-15, "Exploded View"](#).
6. Loosen front lower link mounting bolt and nut from suspension member. Refer to [RSU-15, "Removal and Installation"](#).
7. Remove radius rod mounting bolts and nuts from axle housing with power tool.
8. Remove radius rod mounting bolt from rear suspension member with power tool, then remove radius rod.
9. Perform inspection after removal. Refer to [RSU-13, "Inspection"](#).

INSTALLATION

Note the following, and install in the reverse order of removal.

- Perform final tightening of fixing parts at the vehicle installation position (rubber bushing), under unladen conditions with tires on level ground.
- Never reuse radius rod mounting nut.
- Perform inspection after installation. Refer to [RSU-13, "Inspection"](#).

Inspection

INFOID:000000008380660

INSPECTION AFTER REMOVAL

Check radius rod and bushing for any deformation, cracks, or damage. Replace if necessary.

RADIUS ROD

< REMOVAL AND INSTALLATION >

INSPECTION AFTER INSTALLATION

1. Check wheel sensor harness for proper connection. Refer to [BRC-115. "REAR WHEEL SENSOR : Exploded View"](#).
2. Check wheel alignment. Refer to [RSU-6. "Inspection"](#).

FRONT LOWER LINK

< REMOVAL AND INSTALLATION >

FRONT LOWER LINK

Exploded View

INFOID:000000008380661

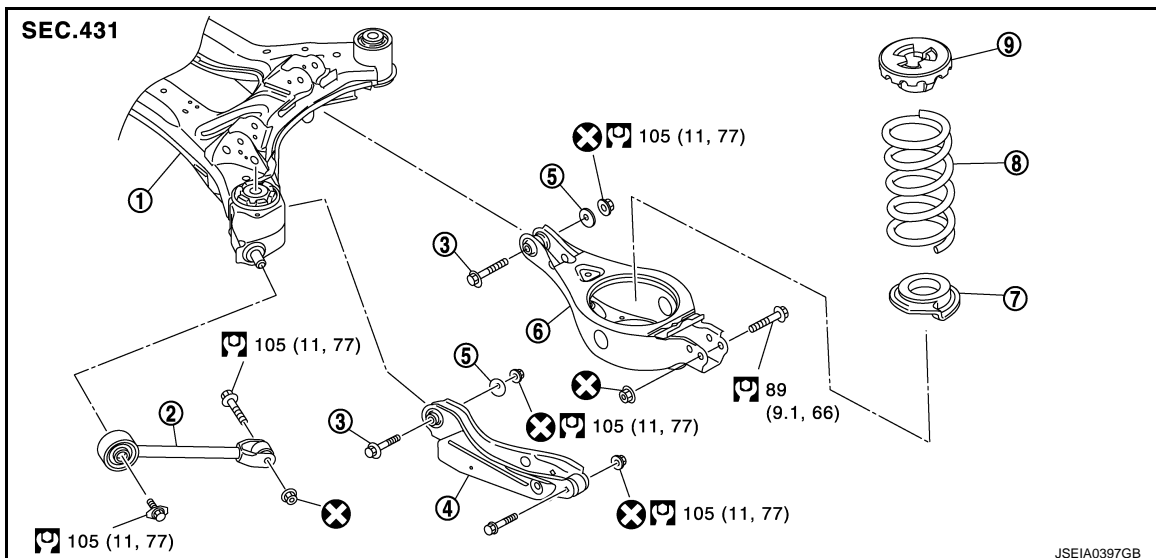

- | | | |
|---------------------------|-------------------|--------------------|
| 1. Rear suspension member | 2. Radius rod | 3. Adjusting bolt |
| 4. Front lower link | 5. Eccentric disk | 6. Rear lower link |
| 7. Rubber seat | 8. Coil spring | 9. Upper seat |

: N·m (kg·m, ft·lb)

: Always replace after every disassembly.

Removal and Installation

INFOID:000000008380662

REMOVAL

1. Remove tire with power tool. Refer to [WT-43. "Exploded View"](#).
2. Remove wheel sensor and sensor harness. Refer to [BRC-115. "REAR WHEEL SENSOR : Removal and Installation"](#).
3. Remove rear lower link and coil spring. Refer to [RSU-8. "Removal and Installation"](#).
4. Separate shock absorber from front lower link. Refer to [RSU-10. "Exploded View"](#).
5. Remove eccentric disc, adjusting bolt, mounting bolt, and nut, then remove front lower link.
6. Perform inspection after removal. Refer to [RSU-15. "Inspection"](#).

INSTALLATION

Note the following, and install in the reverse order of removal.

- Install adjusting bolt so that the graduation marks on adjusting bolt are positioned downward.
- Perform final tightening of fixing parts at the vehicle installation position (rubber bushing), under unladen conditions with tires on level ground.
- Never reuse front lower link mounting nut.
- Perform inspection after installation. Refer to [RSU-15. "Inspection"](#).

Inspection

INFOID:000000008380663

INSPECTION AFTER REMOVAL

Check front lower link and bushing for any deformation, cracks, or damage. Replace it if necessary.

INSPECTION AFTER INSTALLATION

1. Check wheel sensor harness for proper connection. Refer to [BRC-115. "REAR WHEEL SENSOR : Exploded View"](#).

FRONT LOWER LINK

< REMOVAL AND INSTALLATION >

2. Check wheel alignment. Refer to [RSU-6. "Inspection"](#).

SUSPENSION ARM

< REMOVAL AND INSTALLATION >

SUSPENSION ARM

Exploded View

INFOID:000000008380664

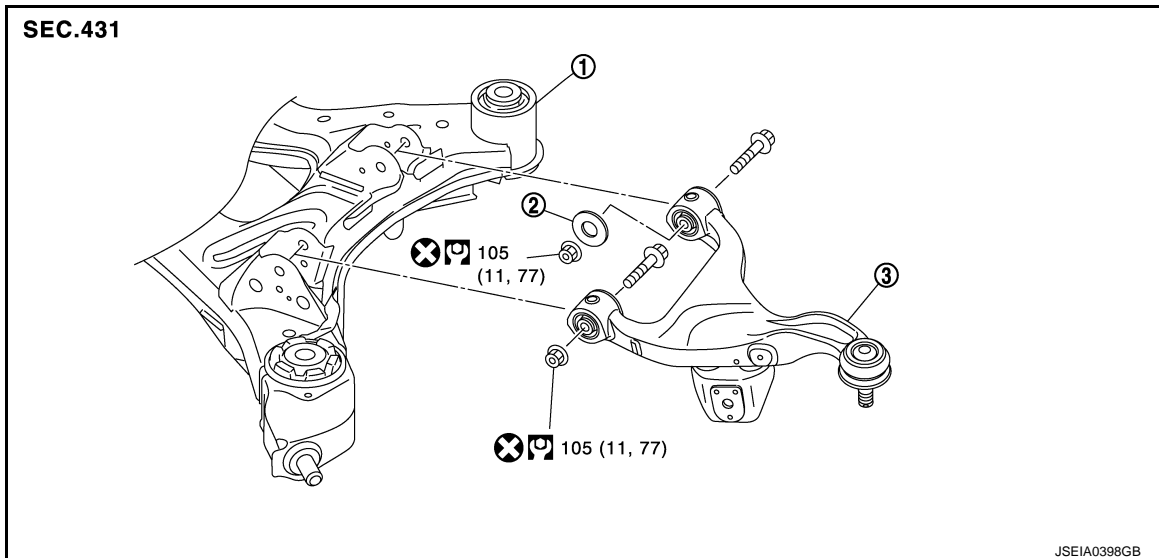

1. Rear suspension member
2. Stopper rubber
3. Suspension arm

: N·m (kg-m, ft-lb)

: Always replace after every disassembly.

Removal and Installation

INFOID:000000008380665

REMOVAL

1. Remove tires with power tool. [WT-43, "Exploded View"](#).
2. Remove wheel sensor and sensor harness. Refer to [BRC-115, "REAR WHEEL SENSOR : Removal and Installation"](#).
3. Separate suspension arm from front lower link. Refer to [RAX-6, "Removal and Installation"](#).
4. Remove mounting bolt, and nut, then remove stopper rubber and suspension arm.
5. Perform inspection after removal. Refer to [RSU-17, "Inspection"](#).

INSTALLATION

Note the following, and install in the reverse order of removal.

- Install stopper rubber to rear suspension member together with suspension arm.
- Perform final tightening of fixing parts at the vehicle installation position (rubber bushing), under unladen conditions with tires on level ground.
- Never reuse suspension arm mounting nut.
- Perform inspection after installation. Refer to [RSU-17, "Inspection"](#).

Inspection

INFOID:000000008380666

INSPECTION AFTER REMOVAL

Check the following items, and replace the parts if necessary.

Suspension Arm

- Suspension arm and bushing for deformation, cracks or damage.
- Ball joint boot for cracks or other damage, and also for grease leakage.

Swing Torque

1. Manually move ball stud to confirm it moves smoothly with no binding.
2. Move ball stud at least ten times by hand to check for smooth movement.

SUSPENSION ARM

< REMOVAL AND INSTALLATION >

- Hook spring balance (A) at cotter pin mounting hole. Confirm spring balance measurement value is within specifications when ball stud begins moving.

Swing torque : Refer to [RSU-21, "Ball Joint"](#).

- If swing torque exceeds standard range, replace suspension arm assembly.

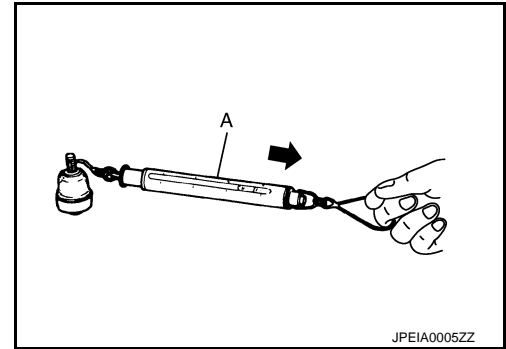

Axial End Play

- Manually move ball stud to confirm it moves smoothly with no binding.
- Move ball stud at least ten times by hand to check for smooth movement.
- Move tip of ball stud in axial direction to check for looseness.

Axial end play : Refer to [RSU-21, "Ball Joint"](#).

- If axial end play exceeds the standard value, replace suspension arm assembly.

INSPECTION AFTER INSTALLATION

- Check wheel sensor harness for proper connection. Refer to [BRC-115, "REAR WHEEL SENSOR : Exploded View"](#).
- Check wheel alignment. Refer to [RSU-6, "Inspection"](#).

REAR SUSPENSION ASSEMBLY

< REMOVAL AND INSTALLATION >

REAR SUSPENSION ASSEMBLY

Exploded View

INFOID:000000008380667

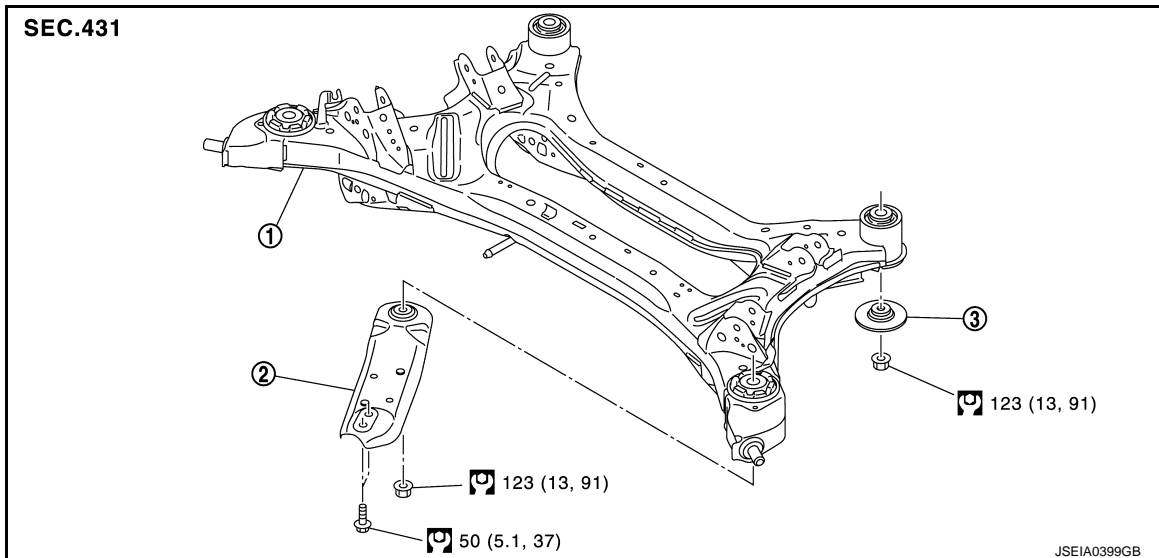

1. Rear suspension member stay
2. Rear suspension member
3. Rebound stopper

: N·m (kg-m, ft-lb)

Removal and Installation

INFOID:000000008380668

REMOVAL

1. Remove tires with power tool. Refer to [WT-43, "Exploded View"](#).
2. Remove caliper assembly. Hang caliper assembly not to interfere with work. Refer to [BR-47, "BRAKE CALIPER ASSEMBLY : Removal and Installation"](#).
CAUTION:
Never depress brake pedal while brake caliper is removed.
3. Remove wheel sensor and sensor harness. Refer to [BRC-115, "REAR WHEEL SENSOR : Removal and Installation"](#).
4. Remove center muffler. Refer to [EX-6, "Removal and Installation"](#).
5. Separate the parking brake cable from rear suspension member. Refer to [PB-6, "Removal and Installation"](#).
6. Remove rear lower link and coil spring. Refer to [RSU-8, "Removal and Installation"](#).
7. Separate shock absorber from front lower link. Refer to [RSU-10, "Removal and Installation"](#).
8. Set jack under rear suspension member.
CAUTION:
 - At this step, the jack must be set only for supporting the removal procedure. For details on jacking up the vehicle, refer to [GI-29, "Garage Jack and Safety Stand and 2-Pole Lift"](#).
 - Never damage the rear suspension member with a jack.
 - Check the stable condition when using a jack.
9. Remove rear suspension member stay.
10. Remove rear suspension member mounting nuts and rebound stopper.
11. Slowly lower jack, then remove rear suspension member, front lower link, radius rod, suspension arm, and axle housing from vehicle as a unit.
CAUTION:
Operate while checking that jack supporting status is stable.
12. Remove the following parts from rear suspension member.
 - Axle housing: Refer to [RAX-6, "Removal and Installation"](#).
 - Suspension arm: Refer to [RSU-17, "Removal and Installation"](#).

REAR SUSPENSION ASSEMBLY

< REMOVAL AND INSTALLATION >

- Radius rod: Refer to [RSU-13, "Removal and Installation"](#).
- Front lower link: Refer to [RSU-15, "Removal and Installation"](#).

13. Perform inspection after removal. Refer to [RSU-20, "Inspection"](#).

INSTALLATION

Note the following, and install in the reverse order of the removal.

- Perform final tightening of fixing parts at the vehicle installation position (rubber bushing), under unladen conditions with tires on level ground.
- Perform inspection after installation. Refer to [RSU-20, "Inspection"](#).

Inspection

INFOID:000000008380669

INSPECTION AFTER REMOVAL

Check rear suspension member for deformation, cracks, or any other damage. Replace it if necessary.

INSPECTION AFTER INSTALLATION

1. Check wheel sensor harness for proper connection. Refer to [BRC-115, "REAR WHEEL SENSOR : Exploded View"](#).
2. Adjust parking brake operation (stroke). Refer to [PB-3, "Inspection and Adjustment"](#).
3. Check wheel alignment. Refer to [RSU-6, "Inspection"](#).

SERVICE DATA AND SPECIFICATIONS (SDS)

< SERVICE DATA AND SPECIFICATIONS (SDS)

SERVICE DATA AND SPECIFICATIONS (SDS)

SERVICE DATA AND SPECIFICATIONS (SDS)

Wheel Alignment

INFOID:000000008380670

FOR USA MODELS

Item		Standard	
Camber Degree minute (Decimal degree)	Minimum	-1° 06' (-1.10°)	
	Nominal	-0° 36' (-0.60°)	
	Maximum	-0° 06' (-0.10°)	
Toe-in	Total toe-in Distance	Minimum	In 1.2 mm (0.047 in)
		Nominal	In 2.8 mm (0.110 in)
		Maximum	In 4.4 mm (0.173 in)
	Total toe-angle Degree minute (Decimal degree)	Minimum	In 0° 06' (In 0.1°)
		Nominal	In 0° 14' (In 0.23°)
		Maximum	In 0° 22' (In 0.37°)

Measure value under unladen* conditions.

*: Fuel, engine coolant and lubricant are full. Spare tire, jack, hand tools and mats are in designated positions.

FOR CANADA MODELS

Item		Standard		
Wheel size		16 inch	18 inch	
Camber Degree minute (Decimal degree)	Minimum	-1° 05' (-1.08°)		
	Nominal	-0° 35' (-0.58°)		
	Maximum	-0° 05' (-0.09°)		
Toe-in	Total toe-in Distance	Minimum	In 0.8 mm (0.031 in)	
		Nominal	In 2.4 mm (0.094 in)	
		Maximum	In 4.0 mm (0.157 in)	
	Total toe-angle Degree minute (Decimal degree)	Minimum	In 0° 04' (In 0.07°)	
		Nominal	In 0° 12' (In 0.2°)	
		Maximum	In 0° 20' (In 0.33°)	

Measure value under unladen* conditions.

*: Fuel, engine coolant and lubricant are full. Spare tire, jack, hand tools and mats are in designated positions.

Ball Joint

INFOID:000000008380671

Item	Standard
Swing torque	0.5 – 3.4 N·m (0.06 – 0.34 kg·m, 5 – 30 in-lb)
Measurement on spring balance	8.1 – 54.8 N (0.83 – 5.6 kg, 1.82 – 12.32 lb)
Axial end play	0 mm (0 in)

Wheelarch Height

INFOID:000000008380672

FOR USA MODELS

SERVICE DATA AND SPECIFICATIONS (SDS)

< SERVICE DATA AND SPECIFICATIONS (SDS)

Item	Standard			
	3.5S	3.5SV	3.5SL	3.5LE
Grade				
Front (Hf)	760 mm (29.92 in)		769 mm (30.28 in)	770 mm (30.31 in)
Rear (Hr)	751 mm (29.57 in)		760 mm (29.92 in)	759 mm (29.88 in)

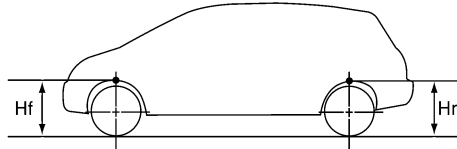

WEIA0030E

Measure value under unladen* conditions.

*: Fuel, engine coolant and lubricant are full. Spare tire, jack, hand tools and mats are in designated positions.

FOR CANADA MODELS

Item	Standard			
	3.5S	3.5SV	3.5SL	3.5LE
Grade				
Front (Hf)	760 mm (29.92 in)		770 mm (30.31 in)	
Rear (Hr)	752 mm (29.61 in)	751 mm (29.57 in)	760 mm (29.92 in)	

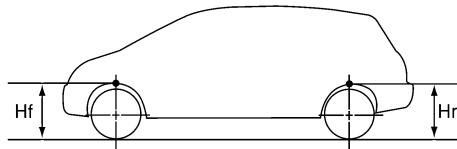

WEIA0030E

Measure value under unladen* conditions.

*: Fuel, engine coolant and lubricant are full. Spare tire, jack, hand tools and mats are in designated positions.