

A
B
C
D

WT

SECTION

ROAD WHEELS & TIRES

WT

CONTENTS

PRECAUTION	WIRING DIAGRAM	F
PRECAUTIONS	TIRE PRESSURE MONITORING SYSTEM	G
Precaution for Supplemental Restraint System (SRS) "AIR BAG" and "SEAT BELT PRE-TENSIONER"	Wiring Diagram	
Service Notice and Precautions for TPMS	BASIC INSPECTION	H
Service Notice and Precautions for Road Wheel	DIAGNOSIS AND REPAIR WORK FLOW	
PREPARATION	Work Flow	I
PREPARATION	ADDITIONAL SERVICE WHEN REPLACING	J
Special Service Tool	BCM	
Commercial Service Tool	Description	K
SYSTEM DESCRIPTION	Work Procedure	L
COMPONENT PARTS	TIRE PRESSURE SENSOR ID REGISTRATION	M
Component Parts Location	Description	
BCM	Work Procedure	N
Tire Pressure Sensor	DTC/CIRCUIT DIAGNOSIS	O
Tire Pressure Receiver	C1704, C1705, C1706, C1707 LOW TIRE	
Information Display	PRESSURE	P
SYSTEM	DTC Logic	
System Description	Diagnosis Procedure	
Circuit Diagram	C1708, C1709, C1710, C1711 TIRE PRES-	
Easy Fill Tire Alert Function	SURE SENSOR	
DIAGNOSIS SYSTEM (BCM)	DTC Logic	
COMMON ITEM	Diagnosis Procedure	
COMMON ITEM : CONSULT Function (BCM -	C1716, C1717, C1718, C1719 TIRE PRES-	
COMMON ITEM)	SURE SENSOR	
AIR PRESSURE MONITOR	DTC Logic	
AIR PRESSURE MONITOR : CONSULT Function	Diagnosis Procedure	
(BCM - AIR PRESSURE MONITOR)	C1729 VEHICLE SPEED SIGNAL	
ECU DIAGNOSIS INFORMATION	DTC Logic	
BCM	Diagnosis Procedure	
List of ECU Reference	POWER SUPPLY AND GROUND CIRCUIT	

Diagnosis Procedure	29	NOISE, VIBRATION AND HARSHNESS (NVH) TROUBLESHOOTING	39
SYMPTOM DIAGNOSIS	30	NVH Troubleshooting Chart	39
TPMS	30	PERIODIC MAINTENANCE	40
Symptom Table	30	ROAD WHEEL	40
LOW TIRE PRESSURE WARNING LAMP DOES NOT TURN ON	33	Inspection	40
Description	33	Wheel Balance Adjustment	40
Diagnosis Procedure	33	Tire Rotation	42
LOW TIRE PRESSURE WARNING LAMP DOES NOT TURN OFF	34	REMOVAL AND INSTALLATION	43
Description	34	ROAD WHEEL TIRE ASSEMBLY	43
Diagnosis Procedure	34	Exploded View	43
LOW TIRE PRESSURE WARNING LAMP BLINKS	35	Removal and Installation	43
Description	35	Inspection	43
Diagnosis Procedure	35	TIRE PRESSURE SENSOR	45
EASY FILL TIRE ALERT DOES NOT ACTI- VATE	36	Exploded View	45
Description	36	Removal and Installation	45
Diagnosis Procedure	36	TIRE PRESSURE RECEIVER	47
TIRE PRESSURE SENSOR ID REGISTRA- TION CANNOT BE COMPLETED	38	Removal and Installation	47
Description	38	SERVICE DATA AND SPECIFICATIONS (SDS)	48
Diagnosis Procedure	38	SERVICE DATA AND SPECIFICATIONS (SDS)	48
		Road Wheel	48
		Tire Air Pressure	48

PRECAUTIONS

< PRECAUTION >

PRECAUTION

PRECAUTIONS

Precaution for Supplemental Restraint System (SRS) "AIR BAG" and "SEAT BELT PRE-TENSIONER"

INFOID:000000008378967

The Supplemental Restraint System such as "AIR BAG" and "SEAT BELT PRE-TENSIONER", used along with a front seat belt, helps to reduce the risk or severity of injury to the driver and front passenger for certain types of collision. This system includes seat belt switch inputs and dual stage front air bag modules. The SRS system uses the seat belt switches to determine the front air bag deployment, and may only deploy one front air bag, depending on the severity of a collision and whether the front occupants are belted or unbelted. Information necessary to service the system safely is included in the "SRS AIR BAG" and "SEAT BELT" of this Service Manual.

WARNING:

Always observe the following items for preventing accidental activation.

- To avoid rendering the SRS inoperative, which could increase the risk of personal injury or death in the event of a collision that would result in air bag inflation, all maintenance must be performed by an authorized NISSAN/INFINITI dealer.
- Improper maintenance, including incorrect removal and installation of the SRS, can lead to personal injury caused by unintentional activation of the system. For removal of Spiral Cable and Air Bag Module, see "SRS AIR BAG".
- Never use electrical test equipment on any circuit related to the SRS unless instructed to in this Service Manual. SRS wiring harnesses can be identified by yellow and/or orange harnesses or harness connectors.

PRECAUTIONS WHEN USING POWER TOOLS (AIR OR ELECTRIC) AND HAMMERS

WARNING:

Always observe the following items for preventing accidental activation.

- When working near the Air Bag Diagnosis Sensor Unit or other Air Bag System sensors with the ignition ON or engine running, never use air or electric power tools or strike near the sensor(s) with a hammer. Heavy vibration could activate the sensor(s) and deploy the air bag(s), possibly causing serious injury.
- When using air or electric power tools or hammers, always switch the ignition OFF, disconnect the battery, and wait at least 3 minutes before performing any service.

Service Notice and Precautions for TPMS

INFOID:000000008378968

- Low tire pressure warning lamp blinks for 1min, then turns ON when occurring any malfunction except low tire pressure. Erase the self-diagnosis memories for Tire Pressure Monitoring System (TPMS), or register the ID to turn low tire pressure warning lamp OFF. For ID registration, refer to [WT-20, "Work Procedure"](#).
- ID registration is required when replacing or rotating wheels, replacing tire pressure sensor or BCM. Refer to [WT-20, "Work Procedure"](#).
- For easy fill tire alert function, refer to the following.
 - When inflating the tires, park the vehicle in the safe area and ensure the safety of the working area.
 - Read and understand the easy fill tire alert function prior to use.
 - Inflate the tires one at a time.
 - If there is no response for approximately 15 seconds or more after inflating the tires, cancel the use of the easy fill tire alert function or move the vehicle approximately 1 m (3.2 ft) backward or forward to try again. The air filler pressure may be weak or out of service area.
 - Despite the high-precision TPMS pressure sensor, an indicated value may differ from that of the pressure gauge.
 - Air pressure is measured rather high due to the rise in tire air temperature after driving.
 - If TPMS is malfunctioning, the easy fill tire alert is unusable.
- Replace grommet seal, valve core and valve cap of tire pressure sensor in TPMS, when replacing each tire by reaching the wear limit. Refer to [WT-45, "Exploded View"](#).
- Because the tire pressure sensor conforms to North America radio law, the following items must be observed.
 - The sensor may be used only in North America.
 - It may not be used in any method other than the specified method.
 - It must not be disassembled or modified.

PRECAUTIONS

< PRECAUTION >

Service Notice and Precautions for Road Wheel

INFOID:000000008378969

- Genuine NISSAN aluminum wheel is designed for each type of vehicle. Use it on the specified vehicle only.
- Use Genuine NISSAN parts for the road wheels, valve caps and wheel nuts.
- Always use them after adjusting the wheel balance. For the balance weights, use Genuine NISSAN aluminum wheel weights.
- Use caution when handling the aluminum wheels, because they can be easily scratched. When removing dirt, do not use any abrasives, a wire brush, or other items that may scratch the coating. Use a neutral detergent if a detergent is needed.
- After driving on roads scattered with anti-icing salts, wash off the wheels completely.
- When installing road wheels onto the vehicle, always wipe off any dirt or foreign substances to prevent them from being trapped between the contact surfaces of wheel.
- Never apply oil to nut and bolt threads.
- When tightening the valve cap there is a risk of damaging the valve cap if a tool is used. Tighten by hand.

PREPARATION

< PREPARATION >

PREPARATION

PREPARATION

Special Service Tool

INFOID:000000008378970

The actual shapes of Kent-Moore tools may differ from those of special service tools illustrated here.

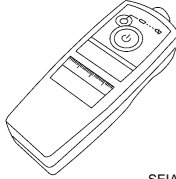
Tool number (Kent-Moore No.) Tool name	Description
— (J-45295) Tire pressure sensor activation tool  SEIA0462E	ID registration

A
B
C
D
WT

Commercial Service Tool

INFOID:000000008378971

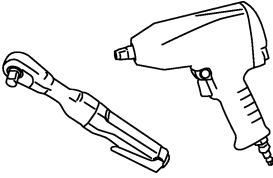
Tool name	Description
Power tool  PBIC0190E	Loosening bolts and nuts

F
G
H
I
J
K
L
M
N
O
P

COMPONENT PARTS

< SYSTEM DESCRIPTION >

SYSTEM DESCRIPTION

COMPONENT PARTS

Component Parts Location

INFOID:000000008378972

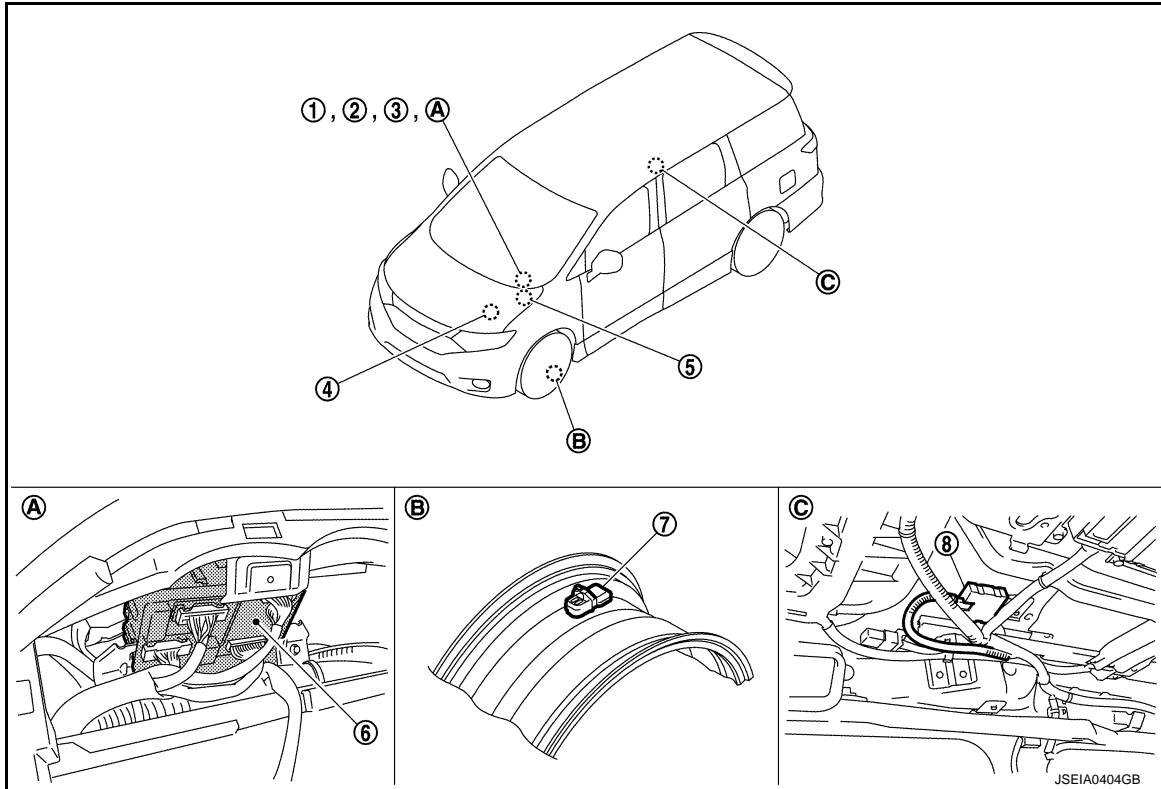

A. Behind of combination meter

B. Wheel

C. View with roof finisher removed

No.	Component parts	Function
1.	Low tire pressure warning lamp (in combination meter)	WT-8. "System Description"
2.	Information display (in combination meter)	WT-7. "Information Display"
3.	Combination meter	Mainly receives the following signals from BCM via CAN communication. <ul style="list-style-type: none"> • Low tire pressure warning lamp signal • TPMS malfunction warning lamp signal
4.	TCM	Mainly transmits the following signals to BCM via CAN communication. <ul style="list-style-type: none"> • P range signal
5.	ABS actuator and electric unit (control unit)	Mainly transmits the following signals to BCM via CAN communication. <ul style="list-style-type: none"> • Vehicle speed signal
6.	BCM	WT-6. "BCM"
7.	Tire pressure sensor	WT-7. "Tire Pressure Sensor"
8.	Remote keyless entry receiver (tire pressure receiver)	WT-7. "Tire Pressure Receiver"

BCM

INFOID:000000008378973

- The BCM reads the air pressure signal received by the tire pressure receiver, controls the low tire pressure warning lamp, hazard warning lamp, and horn operation. It also has a judgment function to detect a system malfunction.
- Controls easy fill tire alert function. Refer to [WT-9. "Easy Fill Tire Alert Function"](#).

COMPONENT PARTS

< SYSTEM DESCRIPTION >

Tire Pressure Sensor

INFOID:000000008378974

The tire pressure sensor integrated with a valve is installed on a wheel, and transmits a detected air pressure signal by radio wave.

Tire Pressure Receiver

INFOID:000000008378975

- Tire pressure receiver is incorporated into remote keyless entry receiver.
- The tire pressure receiver receives the air pressure signal transmitted by the tire pressure sensor in each wheel.

Information Display

INFOID:000000008378976

The vehicle information display is shown when a low tire pressure warning lamp signal is transmitted from BCM to combination meter. via CAN communication.

Condition		Vehicle information display
Ignition switch OFF		Not indicated
Ignition switch ON	Low tire pressure warning lamp remains ON after blinking for one minute. [Tire Pressure Monitoring System (TPMS) malfunction.]	Not indicated
Ignition switch ON	Low tire pressure warning lamp remains ON. (low tire pressure)	Indicated

WT

F

G

H

I

J

K

L

M

N

O

P

SYSTEM

< SYSTEM DESCRIPTION >

SYSTEM

System Description

INFOID:000000008378977

- During driving, the TPMS (Tire Pressure Monitoring System) receives the signal transmitted from tire pressure sensor installed in each wheel. The BCM (Body Control Module) of this system has pressure judgment and trouble diagnosis functions. When the tire pressure monitoring system detects low inflation pressure or another unusual symptom, the low tire pressure warning lamps in the combination meter comes on.
- If the tire pressure is less than the specified value, the low tire pressure warning lamp illuminates that the tire pressure is less than the specified value.
- Activates the TPMS (Tire Pressure Monitoring System) when the vehicle speed is 40 km/h (25 MPH) or more.
- Added easy fill tire alert function to TPMS (Tire Pressure Monitoring System). Refer to [WT-9, "Easy Fill Tire Alert Function"](#).

SYSTEM DIAGRAM

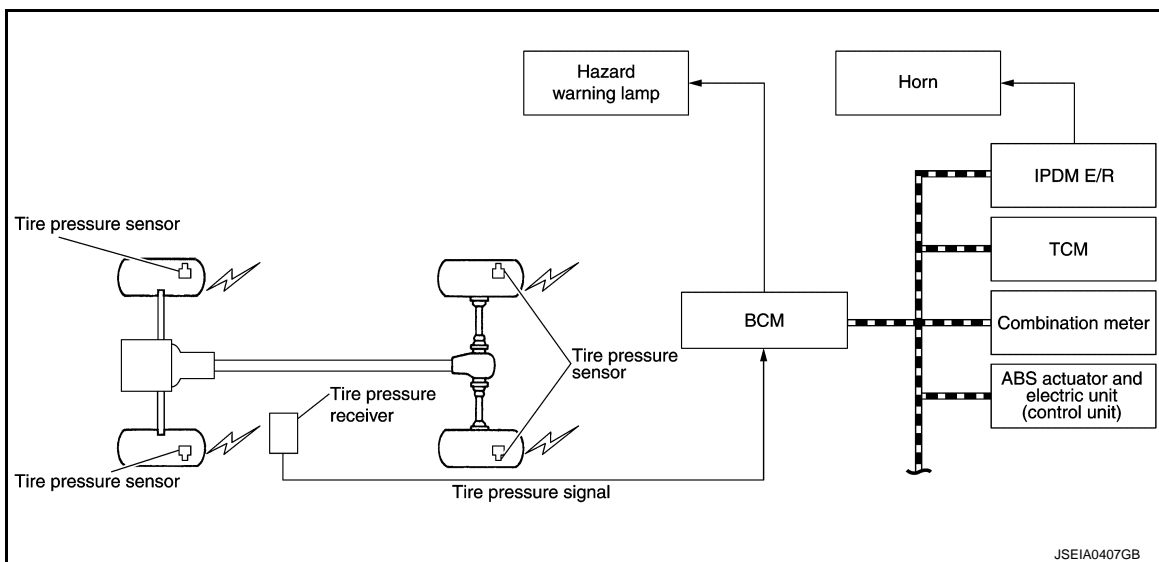

INPUT/OUTPUT SIGNAL

Major signal transmission between each unit via communication lines is shown in the following table.

Component parts	Signal item
Combination meter	Mainly receives the following signals from BCM via CAN communication. <ul style="list-style-type: none"> • Low tire pressure warning lamp signal • TPMS malfunction warning lamp signal
ABS actuator and electric unit (control unit)	Mainly transmits the following signals to BCM via CAN communication. <ul style="list-style-type: none"> • Vehicle speed signal
TCM	Mainly transmits the following signals to BCM via CAN communication. <ul style="list-style-type: none"> • P range signal
IPDM E/R	Mainly receives the following signals from BCM via CAN communication. <ul style="list-style-type: none"> • Horn remainder signal

LOW TIRE PRESSURE WARNING LAMP INDICATION CONDITION

Uses CAN communication from the BCM to illuminate the low tire pressure warning lamp on the combination meter.

Condition	Low tire pressure warning lamp
Ignition switch OFF	OFF
Ignition switch ON (system normal)	Warning lamp turns on for 1second, then turns off.

SYSTEM

< SYSTEM DESCRIPTION >

Condition	Low tire pressure warning lamp
Low tire pressure	ON
Tire pressure sensor ID not registered in BCM	
Tire pressure monitoring system malfunction (Other diagnostic item)	Warning lamp blinks 1 min, then turns on.

HAZARD WARNING LAMP INDICATION CONDITION

The hazard warning lamp blinks under the following conditions.

- When ID registration is completed. Refer to [WT-20, "Work Procedure"](#).
- During the use of the easy fill tire alert function.

HORN CONTROL CONDITION

During the use of easy fill tire alert function.

Circuit Diagram

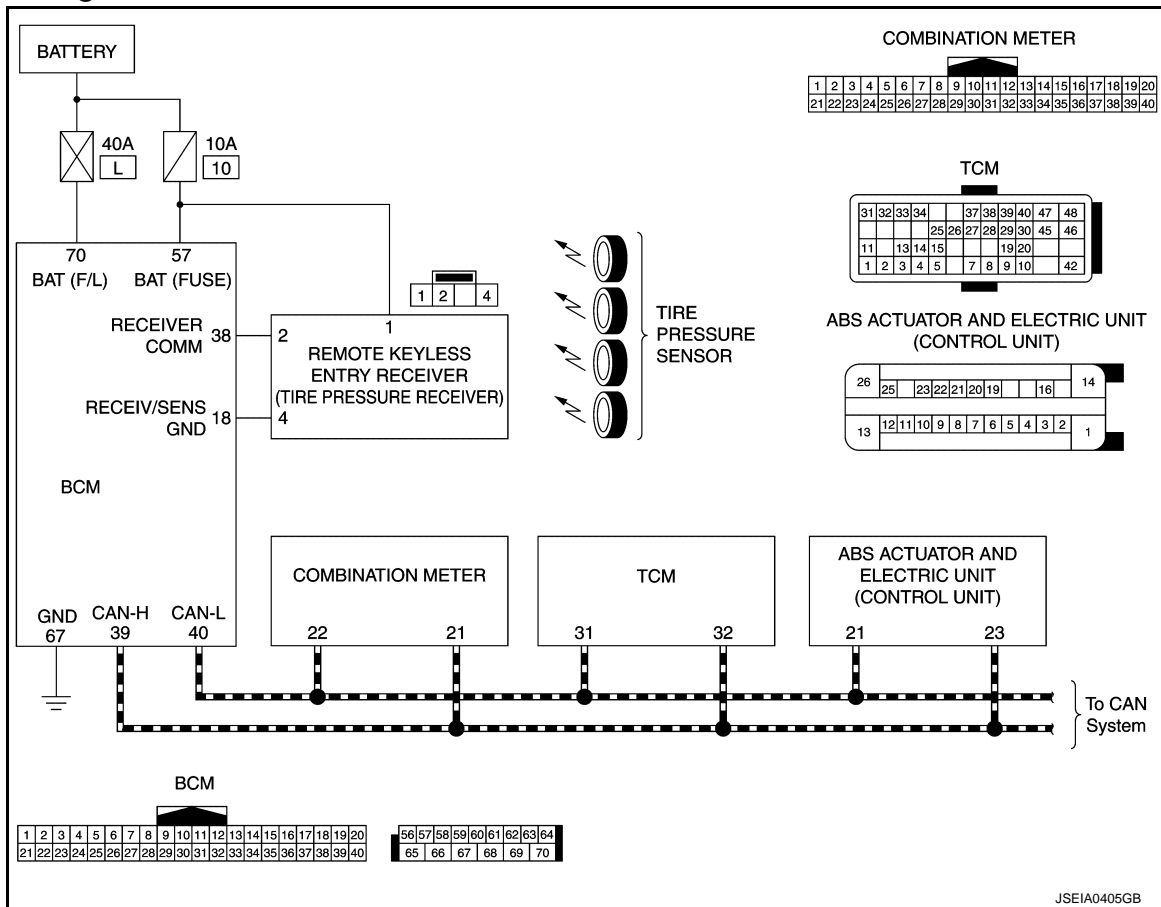

Easy Fill Tire Alert Function

INFOID:000000008378979

- This function operates only when the select lever position is in P-range with the ignition switch ON.

CAUTION:

Never start the engine.

NOTE:

The easy fill tire alert function is recommended to use with the ignition switch ON.

SYSTEM

< SYSTEM DESCRIPTION >

- This function informs the driver of the satisfaction of the recommended COLD tire pressure.
The hazard warning lamp blinks when reaching the recommended COLD tire pressure during radio wave reception. After reaching the recommended COLD tire pressure, the horn sounds once and the hazard warning lamp stops blinking.
- When tire pressure becomes a value equal to or more than 30 kPa (0.31 kg/cm², 4 psi) more than the recommended COLD tire pressure, the hazard warning lamp and the horn operates three times. After deflating the tire and reaching the recommended COLD tire pressure, the horn sounds only once and the hazard warning lamp stops blinking.

NOTE:

- After starting to inflate the tire, it takes a few seconds for the easy fill tire alert to function.
- If there is no response for approximately 15 seconds or more after inflating the tires, cancel the use of the easy fill tire alert function or move the vehicle approximately 1 m (3.2 ft) backward or forward to try again. The air filler pressure may be weak or out of service area.

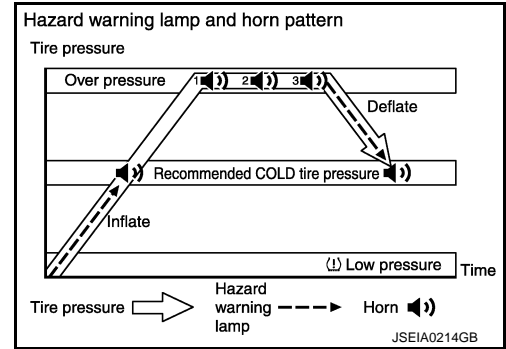

DIAGNOSIS SYSTEM (BCM)

< SYSTEM DESCRIPTION >

DIAGNOSIS SYSTEM (BCM) COMMON ITEM

COMMON ITEM : CONSULT Function (BCM - COMMON ITEM)

INFOID:000000008843739

APPLICATION ITEM

CONSULT performs the following functions via CAN communication with BCM.

Diagnosis mode	Function Description
Work Support	Changes the setting for each system function.
Self Diagnostic Result	Displays the diagnosis results judged by BCM.
CAN Diag Support Monitor	Monitors the reception status of CAN communication viewed from BCM.
Data Monitor	The BCM input/output signals are displayed.
Active Test	The signals used to activate each device are forcibly supplied from BCM.
Ecu Identification	The BCM part number is displayed.
Configuration	<ul style="list-style-type: none"> Read and save the vehicle specification. Write the vehicle specification when replacing BCM.

SYSTEM APPLICATION

BCM can perform the following functions for each system.

NOTE:

It can perform the diagnosis modes except the following for all sub system selection items.

×: Applicable item

System	Sub system selection item	Diagnosis mode		
		Work Support	Data Monitor	Active Test
Door lock	DOOR LOCK	×	×	×
Rear window defogger	REAR DEFOGGER		×	×
Warning chime	BUZZER		×	×
Interior room lamp control system	INT LAMP	×	×	×
Exterior lamp	HEAD LAMP	×	×	×
Wiper and washer	WIPER	×	×	×
Turn signal and hazard warning lamps	FLASHER	×	×	×
Air conditioning control system	AIR CONDITONER		×	×*
<ul style="list-style-type: none"> Intelligent Key system Engine start system 	INTELLIGENT KEY	×	×	×
Combination switch	COMB SW		×	
Body control system	BCM	×		
NVIS	IMMU	×	×	×
Interior room lamp battery saver	BATTERY SAVER	×	×	×
Back door open	TRUNK		×	
Vehicle security system	THEFT ALM	×	×	×
RAP system	RETAINED PWR		×	
Signal buffer system	SIGNAL BUFFER		×	×
TPMS	AIR PRESSURE MONITOR	×	×	×

NOTE:

*: For models with automatic air conditioning control system, this diagnosis mode is not used.

FREEZE FRAME DATA (FFD)

The BCM records the following vehicle condition at the time a particular DTC is detected, and displays on CONSULT.

DIAGNOSIS SYSTEM (BCM)

< SYSTEM DESCRIPTION >

CONSULT screen item	Indication/Unit	Description	
Vehicle Speed	km/h	Vehicle speed of the moment a particular DTC is detected	
Odo/Trip Meter	km	Total mileage (Odometer value) of the moment a particular DTC is detected	
Vehicle Condition	SLEEP>LOCK	Power position status of the moment a particular DTC is detected*	While turning BCM status from low power consumption mode to normal mode [Power supply position is OFF (LOCK)]
	SLEEP>OFF		While turning BCM status from low power consumption mode to normal mode [Power supply position is OFF (OFF)]
	LOCK>ACC		While turning power supply position from OFF (LOCK) to ACC
	ACC>ON		While turning power supply position from ACC to ON
	RUN>ACC		While turning power supply position from RUN to ACC (Except emergency stop operation)
	CRANK>RUN		While turning power supply position from CRANK to RUN
	RUN>URGENT		While turning power supply position from RUN to ACC (Emergency stop operation)
	ACC>OFF		While turning power supply position from ACC to OFF (OFF)
	OFF>LOCK		While turning power supply position from OFF (OFF) to OFF (LOCK)
	OFF>ACC		While turning power supply position from OFF (OFF) to ACC
	ON>CRANK		While turning power supply position from ON to CRANK
	OFF>SLEEP		While turning BCM status from normal mode [Power supply position is OFF (OFF)] to low power consumption mode
	LOCK>SLEEP		While turning BCM status from normal mode [Power supply position is OFF (LOCK)] to low power consumption mode
	LOCK		Power supply position is OFF (LOCK)
	OFF		Power supply position is OFF (OFF)
	ACC		Power supply position is ACC
	ON		Power supply position is ON
	ENGINE RUN		Power supply position is RUN
CRANKING	Power supply position is CRANK		
IGN Counter	0 - 39	The number of times that ignition switch is turned ON after DTC is detected <ul style="list-style-type: none"> • The number is 0 when a malfunction is detected now. • The number increases like 1 → 2 → 3...38 → 39 after returning to the normal condition whenever ignition switch OFF → ON. • The number is fixed to 39 until the self-diagnosis results are erased if it is over 39. 	

NOTE:

*: Refer to the following for details of the power supply position.

- OFF (OFF, LOCK): Ignition switch OFF
- ACC: Ignition switch ACC
- IGN: Ignition switch ON with engine stopped
- RUN: Ignition switch ON with engine running
- CRANK: At engine cranking

Power supply position shifts to "OFF (LOCK)" from "OFF (OFF)", when ignition switch is in the OFF position, shift position is in the P position, and any of the following conditions are met.

- Closing door
- Opening door
- Door is locked using door request switch
- Door is locked using Intelligent Key

The power supply position shifts to "ACC" when the push-button ignition switch (push switch) is pushed at "OFF (LOCK)".

AIR PRESSURE MONITOR

AIR PRESSURE MONITOR : CONSULT Function (BCM - AIR PRESSURE MONI-

DIAGNOSIS SYSTEM (BCM)

< SYSTEM DESCRIPTION >

TOR)

INFOID:000000008378981

APPLICATION ITEM

CONSULT performs the following functions via CAN communication with BCM.

Diagnosis mode	Function Description
Self Diagnostic Result	Retrieve DTC from ECU and display diagnostic items.
Data Monitor	Monitor the input/output signal of the control unit in real time.
Active Test	Send the drive signal from CONSULT to the actuator. The operation check can be performed.
Work Support	This mode enables a technician to adjust some devices faster and more accurately.

SELF DIAGNOSTIC RESULT

Refer to [BCS-63, "DTC Index"](#).

DATA MONITOR MODE

NOTE:

The following table includes information(items)inapplicable to this vehicle. For information(items)applicable to this vehicle, refer to CONSULT display items.

Monitor item (Unit)	Remarks
AIR PRESS FL (kPa, kg/cm2 or Psi)	Tire pressure
AIR PRESS FR (kPa, kg/cm2 or Psi)	
AIR PRESS RR (kPa, kg/cm2 or Psi)	
AIR PRESS RL (kPa, kg/cm2 or Psi)	
ID REGST FL1 (Yet, Done)	Registration ID
ID REGST FR1 (Yet, Done)	
ID REGST RR1 (Yet, Done)	
ID REGST RL1 (Yet, Done)	
WARNING LAMP (On/Off)	Low tire pressure warning lamp
BUZZER (On/Off)	NOTE: This item is displayed, but cannot be use this item.

ACTIVE TEST MODE

NOTE:

After completing the work below, perform an active test.

1. Check ID registration state and perform self-diagnosis.
2. Erase the self-diagnosis result history.

Item	Description
WARNING LAMP	Low tire pressure warning lamp can be turned ON arbitrarily.
ID REGIST WARNING	NOTE: Displayed but not used in TPMS.
RUN FLAT TIRE W/L	NOTE: Displayed but not used in TPMS.
RUN FLAT/T WARN BUZZER	NOTE: Displayed but not used in TPMS.

DIAGNOSIS SYSTEM (BCM)

< SYSTEM DESCRIPTION >

Item	Description
FLASHER	Turn signal lamps can be turned ON arbitrarily.
HORN	This test is able to check to check that the horn sounds.

WORK SUPPORT

Item	Description
ID READ	Registered tire pressure sensor ID can be displayed.
ID REGIST	Tire pressure sensor ID can be registered.

BCM

< ECU DIAGNOSIS INFORMATION >

ECU DIAGNOSIS INFORMATION

BCM

List of ECU Reference

INFOID:0000000008378982

ECU	Reference
BCM	BCS-40, "Reference Value"
	BCS-62, "Fail-safe"
	BCS-62, "DTC Inspection Priority Chart"
	BCS-63, "DTC Index"

A

B

C

D

WT

F

G

H

I

J

K

L

M

N

O

P

TIRE PRESSURE MONITORING SYSTEM

< WIRING DIAGRAM >

WIRING DIAGRAM

TIRE PRESSURE MONITORING SYSTEM

Wiring Diagram

INFOID:000000008378983

For connector terminal arrangements, harness layouts, and alphabets in a  (option abbreviation; if not described in wiring diagram), refer to [GI-12. "Connector Information"](#).

TIRE PRESSURE MONITORING SYSTEM

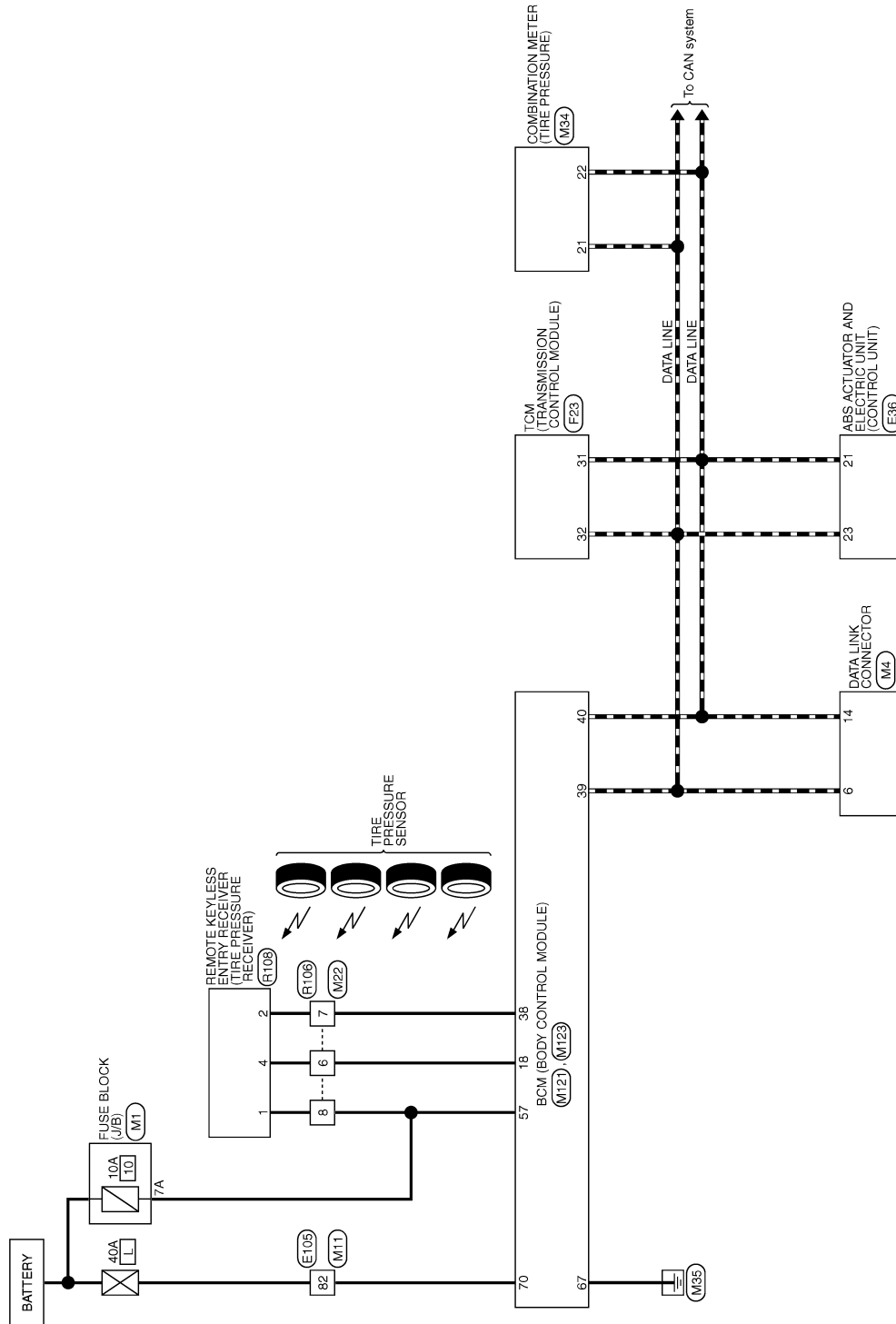

2010/12/13

JCEWA0241GB

DIAGNOSIS AND REPAIR WORK FLOW

< BASIC INSPECTION >

BASIC INSPECTION

DIAGNOSIS AND REPAIR WORK FLOW

Work Flow

INFOID:000000008378984

DETAILED FLOW

1. COLLECT THE INFORMATION FROM THE CUSTOMER

It is also important to clarify customer concerns before starting the inspection. Reproduce the symptom, and understand it fully. Interview the customer about the concerns carefully. In some cases, it is necessary to check the symptoms by driving the vehicle with the customer.

CAUTION:

Customers are not professionals. Never assume “maybe the customer means...” or “maybe the customer mentioned this symptom.”

>> GO TO 2.

2. BASIC INSPECTION

1. Turn the ignition switch ON.

CAUTION:

Never start the engine.

2. Check the tire pressure for all wheels and adjust to the specified value. Refer to [WT-48, "Tire Air Pressure"](#).

Is the inspection result normal?

YES >> GO TO 3.

NO >> Inspect or repair the tires or wheels.

3. CHECK LOW TIRE PRESSURE WARNING LAMP

Check low tire pressure warning lamp display.

Does not low tire pressure warning lamp turn OFF?

YES >> GO TO 4.

NO >> GO TO 8.

4. PERFORM SELF-DIAGNOSIS

 **With CONSULT**

Perform “SELF-DIAG RESULTS”.

Is any DTC detected?

YES >> Record or print DTC and freeze frame data (FFD). GO TO 5.

NO >> GO TO 7.

5. RECHECK THE SYMPTOM

 **With CONSULT**

Perform “DTC CONFIRMATION PROCEDURE” with recorded DTC.

If two or more DTCs are detected, refer to [BCS-63, "DTC Index"](#) and determine trouble diagnosis order.

Is any DTC detected?

YES >> GO TO 6.

NO >> GO TO 7.

6. REPAIR OR REPLACE ERROR-DETECTED PART

- Repair or replace error-detected parts.
- Reconnect part or connector after repairing or replacing.
- When DTC is detected, erase self-diagnostic result in “AIR PRESSURE MONITOR” of “BCM”.

>> GO TO 9.

7. CRUISE FOR SYMPTOM CHECK

A

B

C

D

WT

F

G

H

I

J

K

L

M

N

O

P

DIAGNOSIS AND REPAIR WORK FLOW

< BASIC INSPECTION >

1. Start the engine.
2. Drive for 10 minutes at a speed of 40 km/h (25 MPH) or more, then stop the vehicle.
CAUTION:
Total time driving at a speed of 40 km/h (25 MPH) or more must be 10 minutes.

>> GO TO 8.

8. IDENTIFY ERROR-DETECTED SYSTEM BY SYMPTOM DIAGNOSIS

Estimate error-detected system based on symptom diagnosis.

>> GO TO 10.

9. FINAL CHECK (WHEN DTC WAS DETECTED)

With CONSULT

Perform "DTC CONFIRMATION PROCEDURE" with displayed DTC.

Is any DTC detected?

- YES >> GO TO 6.
NO >> INSPECTION END

10. FINAL CHECK (WHEN SYMPTOM OCCURRED)

Make sure that the symptom is not detected.

Does symptom remain?

- YES >> GO TO 8.
NO >> INSPECTION END

ADDITIONAL SERVICE WHEN REPLACING BCM

< BASIC INSPECTION >

ADDITIONAL SERVICE WHEN REPLACING BCM

Description

INFOID:000000008378985

When replacing BCM, tire pressure sensor ID registration is required.

Work Procedure

INFOID:000000008378986

1. PERFORM TIRE PRESSURE SENSOR ID REGISTRATION

Perform tire pressure sensor ID registration.

>> Refer to [WT-20. "Work Procedure"](#).

A

B

C

D

WT

F

G

H

I

J

K

L

M

N

O

P

TIRE PRESSURE SENSOR ID REGISTRATION

< BASIC INSPECTION >

TIRE PRESSURE SENSOR ID REGISTRATION

Description

INFOID:000000008378987

This procedure must be done after replacing or rotating wheels, replacing tire pressure sensor or BCM.

Work Procedure

INFOID:000000008378988

1. TIRE PRESSURE SENSOR ID REGISTRATION PROCEDURE

CAUTION:

To perform ID registration, observe the following points:

- Never register ID in a place where radio waves are interfered (e.g. radio tower).
- Never register ID in a place close to vehicles including TPMS.

Ⓟ With CONSULT

1. Display the "WORK SUPPORT" screen and select "ID REGIST".

Is the tire pressure sensor activation tool (J-45295) used for the tire pressure sensor ID registration procedure?

- YES >> GO TO 2.
NO >> GO TO 3.

2. TIRE PRESSURE SENSOR ID REGISTRATION PROCEDURE (WITH TIRE PRESSURE SENSOR ACTIVATION TOOL)

1. Turn the ignition switch ON.
2. Select the start button on the "ID REGIST" screen.
3. Contact the tire pressure sensor activation tool (J-45295) (1) to the side of the tire at the location to the tire pressure sensor.
4. Press and hold the tire pressure sensor activation tool button while pushing the tool to the tire surface. (approximately for 5 seconds)

CAUTION:

Perform the ID registration procedure starting from the vehicle front left wheel, then repeat the procedure in the order of the front right wheel, rear right wheel, and rear left wheel.

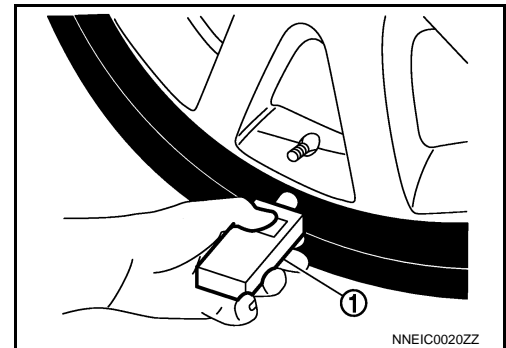

NNEIC0020ZZ

5. When ID registration is completed, check the following pattern at each wheel.

Sequence	ID registration position	Turn signal lamp	CONSULT
1	Front left wheel	2 blinks	"Red" ↓ "Green"
2	Front right wheel		
3	Rear right wheel		
4	Rear left wheel		

6. After the ID registration procedure for all wheels is completed, press "END" to end ID registration, and check that ID registration for all wheels is completed.

Is the check result normal?

- YES >> ID registration END.
NO >> Refer to [WT-38. "Diagnosis Procedure"](#).

3. TIRE PRESSURE SENSOR ID REGISTRATION PROCEDURE (WITHOUT TIRE PRESSURE SENSOR ACTIVATION TOOL)

1. Adjust the tire pressure for all wheels to match the list below.

TIRE PRESSURE SENSOR ID REGISTRATION

< BASIC INSPECTION >

Tire position	Tire pressure kPa (kg/cm ² , psi)
Front LH	240 (2.4, 35)
Front RH	220 (2.2, 31)
Rear RH	200 (2.0, 29)
Rear LH	180 (1.8, 26)

2. Drive the vehicle at a speed at more than 40 km/h (25 MPH) for 3 minutes or more, then perform the tire pressure sensor ID registration procedure.
3. After ID registration for all wheels is completed, press "END" to end ID registration.

ID registration position	CONSULT
Front LH	"Red" ↓ "Green"
Front RH	
Rear RH	
Rear LH	

4. Adjust the tire pressures for all wheels to the specified value. Refer to [WT-48. "Tire Air Pressure"](#).
Is ID registrations for all wheels completed?

- YES >> ID registration END.
 NO >> Performs trouble-diagnosis of the Tire Pressure Monitoring System (TPMS).

A
B
C
D
E
F
G
H
I
J
K
L
M
N
O
P

WT

C1704, C1705, C1706, C1707 LOW TIRE PRESSURE

< DTC/CIRCUIT DIAGNOSIS >

DTC/CIRCUIT DIAGNOSIS

C1704, C1705, C1706, C1707 LOW TIRE PRESSURE

DTC Logic

INFOID:000000008378989

DTC DETECTION LOGIC

DTC	Display Item	Malfunction detected condition	Possible causes
C1704	LOW PRESSURE FL	Front LH tire pressure drops to * kPa (* kg/cm ² , * psi) or less.	Low tire pressure
C1705	LOW PRESSURE FR	Front RH tire pressure drops to * kPa (* kg/cm ² , * psi) or less.	
C1706	LOW PRESSURE RR	Rear RH tire pressure drops to * kPa (* kg/cm ² , * psi) or less.	
C1707	LOW PRESSURE RL	Rear LH tire pressure drops to * kPa (* kg/cm ² , * psi) or less.	

*:189.6 kPa (1.9 kg/cm², 27 psi) [Standard air pressure is for 240 kPa (2.4 kg/cm², 35 psi) vehicles.]

DTC CONFIRMATION PROCEDURE

1. PERFORM DTC CONFIRMATION

With CONSULT

1. Turn the ignition switch ON.

CAUTION:

Never start the engine.

2. Check the tire pressure for all wheels and adjust to the specified value. Refer to [WT-48, "Tire Air Pressure"](#).
3. Perform self-diagnosis for "AIR PRESSURE MONITOR".

Is DTC "C1704", "C1705", "C1706", or "C1707" detected?

YES >> Proceed to [WT-22, "Diagnosis Procedure"](#).

NO >> INSPECTION END

Diagnosis Procedure

INFOID:000000008378990

1. TIRE PRESSURE SENSOR ID REGISTRATION

Perform tire pressure sensor ID registration. Refer to [WT-20, "Work Procedure"](#).

Is tire pressure sensor ID registration completed?

YES >> GO TO 2.

NO >> Replace applicable tire pressure sensor. Refer to [WT-45, "Removal and Installation"](#).

2. CHECK TIRE PRESSURE

Check the air pressure of all wheels. Refer to [WT-48, "Tire Air Pressure"](#).

CAUTION:

If the checked value is close to the standard, reduce the tire pressure, and then with the ignition switch ON, adjust the tire pressure again so that it is within the standard.

Is the inspection result normal?

YES >> Perform "DTC CONFIRMATION PROCEDURE" (self-diagnosis) again. Refer to [BCS-63, "DTC Index"](#).

NO >> After adjusting the air pressure, GO TO 3

3. CHECK TIRE PRESSURE SIGNAL

With CONSULT

1. Select "DATA MONITOR" in "AIR PRESSURE MONITOR" of "BCM".
2. Check that the tire pressures match the standard value.

Monitor item	Displayed value
AIR PRESS FL	Approximately equal to the indication on tire gauge value for front LH tire
AIR PRESS FR	Approximately equal to the indication on tire gauge value for front RH tire

C1704, C1705, C1706, C1707 LOW TIRE PRESSURE

< DTC/CIRCUIT DIAGNOSIS >

Monitor item	Displayed value
AIR PRESS RR	Approximately equal to the indication on tire gauge value for rear RH tire
AIR PRESS RL	Approximately equal to the indication on tire gauge value for rear LH tire

Is the inspection result normal?

- YES >> After erasing DTC record, INSPECTION END.
- NO >> Repair or replace error-detected parts.

A
B
C
D
E
F
G
H
I
J
K
L
M
N
O
P

WT

C1708, C1709, C1710, C1711 TIRE PRESSURE SENSOR

< DTC/CIRCUIT DIAGNOSIS >

C1708, C1709, C1710, C1711 TIRE PRESSURE SENSOR

DTC Logic

INFOID:000000008378991

DTC DETECTION LOGIC

DTC	Display Item	Malfunction detected condition	Possible causes
C1708	[NO DATA] FL	Tire pressure data signal from the front LH wheel tire pressure sensor cannot be detected.	<ul style="list-style-type: none">• Harness or connector (Tire pressure receiver, BCM)• Tire pressure sensor ID registration incomplete• Tire pressure sensor• Tire pressure sensor battery voltage• Driving in area where radio wave cannot be transmitted/received.
C1709	[NO DATA] FR	Tire pressure data signal from the front RH wheel tire pressure sensor cannot be detected.	
C1710	[NO DATA] RR	Tire pressure data signal from the rear RH wheel tire pressure sensor cannot be detected.	
C1711	[NO DATA] RL	Tire pressure data signal from the rear LH wheel tire pressure sensor cannot be detected.	

DTC CONFIRMATION PROCEDURE

1. TIRE PRESSURE SENSOR ID REGISTRATION

Perform tire pressure sensor ID registration. Refer to [WT-20, "Work Procedure"](#).

>> GO TO 2.

2. PERFORM DTC CONFIRMATION

With CONSULT

1. Drive the vehicle at 40 km/h (25 MPH) or more for 10 minutes.

CAUTION:

Total time driving at a speed of 40 km/h (25 MPH) or more must be 10 minutes.

NOTE:

Avoid driving in area where radio wave cannot be transmitted/received.

2. Stop the vehicle.
3. Perform self-diagnosis for "AIR PRESSURE MONITOR" of "BCM".

Is DTC "C1708", "C1709", "C1710" or "C1711" detected?

- YES >> Proceed to [WT-24, "Diagnosis Procedure"](#).
NO >> INSPECTION END

Diagnosis Procedure

INFOID:000000008378992

1. CHECK TIRE PRESSURE SIGNAL

With CONSULT

1. Select "DATA MONITOR" in "AIR PRESSURE MONITOR" of "BCM".
2. Check the values that are displayed for "AIR PRESS FL", "AIR PRESS FR", "AIR PRESS RR", and "AIR PRESS RL".

Are all tire pressures displayed 0 kPa (psi)?

- YES >> GO TO 2.
NO >> Replace applicable tire pressure sensor. Refer to [WT-45, "Removal and Installation"](#).

2. CHECK RECEIVER CIRCUIT

1. Turn the ignition switch OFF.
2. Remove 10A fuse (#10).
3. Disconnect BCM harness connector and tire pressure receiver harness connector.
4. Check the continuity between BCM harness connector and tire pressure receiver harness connector.

C1708, C1709, C1710, C1711 TIRE PRESSURE SENSOR

< DTC/CIRCUIT DIAGNOSIS >

BCM		Tire pressure receiver		Continuity
Connector	Terminal	Connector	Terminal	
M121	18	R108	4	Existed
	38		2	
M123	57		1	

5. Check the continuity between BCM harness connector and ground.

BCM		—	Continuity
Connector	Terminal		
M121	18	Ground	Not existed
	38		
M123	57		

Is the inspection result normal?

YES >> GO TO 3.

NO >> Repair or replace error-detected parts.

3. CHECK TIRE PRESSURE RECEIVER IGNITION SUPPLY CIRCUIT

1. Connect tire pressure receiver harness connector.
2. Install 10A fuse (#10).

CAUTION:

Check that the fuse is not blown, that there are no other abnormalities, and that the fuse is of the specified capacity.

3. Check the voltage between tire pressure receiver harness connector and the ground when the ignition switch is turned ON and OFF.

CAUTION:

Never start the engine.

Tire pressure receiver		—	Voltage
Connector	Terminal		
R108	1	Ground	9 – 16 V

Is the inspection result normal?

YES >> GO TO 4.

NO >> Repair or replace error-detected parts.

4. CHECK TIRE PRESSURE SIGNAL

Check the function tire pressure receiver. Refer to [DLK-234. "Component Function Check"](#).

Is the inspection result normal?

YES >> Replace the BCM.

NO >> Repair or replace error-detected parts.

C1716, C1717, C1718, C1719 TIRE PRESSURE SENSOR

< DTC/CIRCUIT DIAGNOSIS >

C1716, C1717, C1718, C1719 TIRE PRESSURE SENSOR

DTC Logic

INFOID:000000008378993

DTC DETECTION LOGIC

DTC	Display Item	Malfunction detected condition	Possible causes
C1716	[PRESSDATA ERR] FL	Malfunction in the tire pressure data from the front LH wheel tire pressure sensor.	<ul style="list-style-type: none">Excessive tire pressureTire pressure sensor ID registration incompleteTire pressure sensor
C1717	[PRESSDATA ERR] FR	Malfunction in the tire pressure data from the front RH wheel tire pressure sensor.	
C1718	[PRESSDATA ERR] RR	Malfunction in the tire pressure data from the rear RH wheel tire pressure sensor.	
C1719	[PRESSDATA ERR] RL	Malfunction in the tire pressure data from the rear LH wheel tire pressure sensor.	

DTC CONFIRMATION PROCEDURE

1. PERFORM DTC CONFIRMATION

With CONSULT

- Turn the ignition switch ON.

CAUTION:

Never start the engine.

- Check the tire pressure for all wheels and adjust to the specified value. Refer to [WT-48, "Tire Air Pressure"](#).

CAUTION:

If the tire pressure before adjustment is close to the standard, reduce the tire pressure, and then with the ignition switch ON, adjust the tire pressure again so that it is within the standard.

- Perform self-diagnosis in "AIR PRESSURE MONITOR" of "BCM".

Is DTC "C1716", "C1717", "C1718", or "C1719" detected?

YES >> GO TO 2.

NO >> INSPECTION END

2. CHECK LOW TIRE PRESSURE WARNING LAMP

Check that after the ignition switch is turned ON, the low tire pressure warning lamp illuminates for approximately 1 second and then turns OFF.

Is the inspection result normal?

YES >> After erase DTC, INSPECTION END.

NO >> Leave the ignition switch ON and proceed to [WT-26, "Diagnosis Procedure"](#).

Diagnosis Procedure

INFOID:000000008378994

1. PERFORM TIRE PRESSURE SENSOR ID REGISTRATION

Perform tire pressure sensor ID registration for all wheels. Refer to [WT-20, "Work Procedure"](#).

Is tire pressure sensor ID registration completed?

YES >> GO TO 2.

NO >> Replace tire pressure sensor. Refer to [WT-45, "Removal and Installation"](#).

2. CHECK TIRE PRESSURE SIGNAL

With CONSULT

- Check the tire pressure for all wheels and adjust to the specified value. Refer to [WT-48, "Tire Air Pressure"](#).

- Stop the vehicle.

- Select "DATA MONITOR" in "AIR PRESSURE MONITOR" of "BCM".

- Within 15 minutes after vehicle stopped, read the values that are displayed for "AIR PRESS FL", "AIR PRESS FR", "AIR PRESS RR", and "AIR PRESS RL".

Which tire pressures is displayed as 438.60 kPa (4.47 kg/cm², 63.60 psi)?

C1716, C1717, C1718, C1719 TIRE PRESSURE SENSOR

< DTC/CIRCUIT DIAGNOSIS >

- YES >> Replace tire pressure sensor the tire pressure as 438.60 kPa (4.47 kg/cm², 63.60 psi) displayed. Refer to [WT-45, "Removal and Installation"](#).
- NO >> Perform "DTC CONFIRMATION PROCEDURE" (self-diagnosis) again. Refer to [BCS-63, "DTC Index"](#).

A
B
C
D
E
F
G
H
I
J
K
L
M
N
O
P

WT

C1729 VEHICLE SPEED SIGNAL

< DTC/CIRCUIT DIAGNOSIS >

C1729 VEHICLE SPEED SIGNAL

DTC Logic

INFOID:000000008378995

DTC DETECTION LOGIC

DTC	Display Item	Malfunction detected condition	Possible causes
C1729	VHCL SPEED SIG ERR	Vehicle speed signal not detected.	With intelligent key <ul style="list-style-type: none">• CAN communication• BCM• ABS actuator and electric unit (control unit) malfunction

DTC CONFIRMATION PROCEDURE

1. DTC CONFIRMATION PROCEDURE

With CONSULT

1. Drive the vehicle.
2. Stop the vehicle.
3. Perform self-diagnosis in "AIR PRESSURE MONITOR" of "BCM".

Is DTC "C1729" detected?

YES >> Proceed to [WT-28, "Diagnosis Procedure"](#).

NO >> INSPECTION END

Diagnosis Procedure

INFOID:000000008378996

1. PERFORM ABS ACTUATOR AND ELECTRIC UNIT (CONTROL UNIT) SELF-DIAGNOSIS

With CONSULT

Perform self-diagnosis for "ABS".

Is any DTCs detected?

YES >> Check the DTCs.

NO >> GO TO 2.

2. CHECK BCM INPUT/OUTPUT SIGNAL

Check BCM input/output signal values. Refer to [BCS-40, "Reference Value"](#).

Is the inspection result normal?

YES >> Check pin terminal and connection of each harness connector for malfunctioning conditions.

NO >> Replace the BCM. Refer to [BCS-86, "Removal and Installation"](#).

POWER SUPPLY AND GROUND CIRCUIT

< DTC/CIRCUIT DIAGNOSIS >

POWER SUPPLY AND GROUND CIRCUIT

Diagnosis Procedure

INFOID:000000008378997

1. CHECK BCM POWER SUPPLY AND GROUND CIRCUIT

Check BCM power supply and ground. Refer to [BCS-79, "Diagnosis Procedure"](#).

Is the inspection result normal?

YES >> INSPECTION END

NO >> Repair open circuit or short to ground or short to power in harness or connectors.

A
B
C
D
E
F
G
H
I
J
K
L
M
N
O
P

WT

< SYMPTOM DIAGNOSIS >

SYMPTOM DIAGNOSIS

TPMS















Symptom Table

INFOID:000000008378998

LOW TIRE PRESSURE WARNING LAMP SYMPTOM CHART

TPMS

< SYMPTOM DIAGNOSIS >

Diagnosis items	Symptom (Ignition switch ON)	Low tire pressure warning lamp	Cause	Action
Low tire pressure warning lamp	The low tire pressure warning lamp illuminates for 1 second, then turns OFF.	  ON 1 sec > stays OFF <small>SEIA0592E</small>	Wake-up operation for all tire pressure sensors at wheels is completed.	No system malfunctions
	The low tire pressure warning lamp repeats blinking ON for 2 seconds and OFF for 0.2 seconds.	 Blinks:  ON 2 sec > OFF 0.2 sec <small>SEIA0593E</small>	Wake-up operation for all tire pressure sensors at wheels is not completed.	Perform the ID registration for all tire pressure sensors at wheels. Refer to WT-20, "Work Procedure" .
	The low tire pressure warning lamp blinks once.	 Blinks 1 time ON 0.3 sec > OFF 1.0 sec <small>JPEIC0090GB</small>	The front left tire pressure sensor is not activated.	Perform the ID registration for the tire pressure sensor at front left wheel. Refer to WT-20, "Work Procedure" .
	The low tire pressure warning lamp repeats blinking twice.	  Blinks 2 times ON 0.3 sec > OFF 0.3 sec <small>SEIA0595E</small>	The front right tire pressure sensor is not activated.	Perform the ID registration for the tire pressure sensor at front right wheel. Refer to WT-20, "Work Procedure" .
	The low tire pressure warning lamp repeats blinking for 3 times.	   Blinks 3 times ON 0.3 sec > OFF 0.3 sec <small>SEIA0596E</small>	The rear right tire pressure sensor is not activated.	Perform the ID registration for the tire pressure sensor at rear right wheel. Refer to WT-20, "Work Procedure" .
	The low tire pressure warning lamp repeats blinking for 4 times.	    Blinks 4 times ON 0.3 sec > OFF 0.3 sec <small>SEIA0597E</small>	The rear left tire pressure sensor is not activated.	Perform the ID registration for the tire pressure sensor at rear left wheel. Refer to WT-20, "Work Procedure" .
	The low tire pressure warning lamp turns ON and stays illuminated.	 Comes ON and stays ON <small>SEIA0598E</small>	Low tire pressure	Check the tire pressure for all wheels and adjust to the specified value. Refer to WT-48, "Tire Air Pressure" .

A
B
C
D
WT
F
G
H
I
J
K
L
M
N
O
P

TPMS

< SYMPTOM DIAGNOSIS >

Diagnosis items	Symptom (Ignition switch ON)	Low tire pressure warning lamp	Cause	Action
Low tire pressure warning lamp	The low tire pressure warning lamp repeats blinking at 0.5-second intervals for 1 minute, and then stays illuminated.	 <p style="text-align: center;">Blinks 1 min</p> <p style="text-align: center;">ON 0.5 sec > OFF 0.5 sec and stays ON</p> <p style="text-align: center;"><small>SEIA0788E</small></p>	The combination meter fuse is open or removed (or pulled out).	Check and install the combination meter fuse. If necessary, replace the fuse.
			The BCM harness connector is removed.	Check the connection conditions of the BCM harness connector, and repair if necessary.
			Tire Pressure Monitoring System (TPMS) malfunction.	<ul style="list-style-type: none"> Perform CONSULT self-diagnosis. Refer to WT-12, "AIR PRESSURE MONITOR : CONSULT Function (BCM - AIR PRESSURE MONITOR)". If necessary, perform tire pressure sensor ID registration. Refer to WT-20, "Work Procedure".

NOTE:

If tire pressure sensor wake-up operation is not completed for two or more tire pressure sensors, the applicable low tire pressure warning lamp blinking patterns are displayed continuously.

(Example: Blinks once/OFF/blinks 3 times = Wake-up operation is not completed at the front left wheel and rear right wheel tire pressure sensors.)

LOW TIRE PRESSURE WARNING LAMP DOES NOT TURN ON

< SYMPTOM DIAGNOSIS >

LOW TIRE PRESSURE WARNING LAMP DOES NOT TURN ON

Description

INFOID:000000008378999

The low tire pressure warning lamp does not illuminate when the ignition switch is turned ON.

NOTE:

The low tire pressure warning lamp illuminates for approximately 1 second and then turns OFF when the ignition switch is turned ON. This is to check that no abnormal condition is present in the tire pressure monitoring system.

The lamp bulb may be burnt out or the tire pressure monitoring system may be malfunctioning if the low tire pressure warning lamp does not illuminate when the ignition switch is turned ON.

Diagnosis Procedure

INFOID:000000008379000

1. CHECK LOW TIRE PRESSURE WARNING LAMP SIGNAL

With CONSULT

1. Turn the ignition switch ON.

CAUTION:

Never start the engine.

2. Select "ACTIVE TEST" in "AIR PRESSURE MONITOR" of "BCM".
3. Touch "WARNING LAMP" to turn ON the low tire pressure warning lamp.

When "ACTIVE TEST" is performed, does the low tire pressure warning lamp in the combination meter turn ON?

YES >> GO TO 2.

NO >> GO TO 3.

2. CHECK LOW TIRE PRESSURE WARNING LAMP OPERATION

Check that the low tire pressure warning lamp is turned OFF after turns ON for approximately 1 second, when the ignition switch is turned ON.

Is the inspection result normal?

YES >> Check intermittent incident. Refer to [GI-42, "Intermittent Incident"](#).

NO >> Replace the BCM. Refer to [BCS-86, "Removal and Installation"](#).

3. CHECK COMBINATION METER POWER SUPPLY CIRCUIT

Perform the trouble diagnosis for combination meter power supply circuit. Refer to [WT-29, "Diagnosis Procedure"](#).

Is the inspection result normal?

YES-1 >> INSPECTION END

NO >> Repair or replace error-detected parts.

A

B

C

D

WT

F

G

H

I

J

K

L

M

N

O

P

LOW TIRE PRESSURE WARNING LAMP DOES NOT TURN OFF

< SYMPTOM DIAGNOSIS >

LOW TIRE PRESSURE WARNING LAMP DOES NOT TURN OFF

Description

INFOID:000000008379001

The low tire pressure warning lamp does not turn OFF after several seconds is passed after engine starts.

Diagnosis Procedure

INFOID:000000008379002

1. CHECK TIRE PRESSURE

1. Turn the ignition switch ON.

CAUTION:

Never start the engine.

2. Check the tire pressure for all wheels and adjust to the specified value. Refer to [WT-48, "Tire Air Pressure"](#).

Is the inspection result normal?

YES >> GO TO 2.

NO >> Inspect or repair the tires or wheels.

2. CHECK LOW TIRE PRESSURE WARNING LAMP

Check low tire pressure warning lamp display.

Does not low tire pressure warning lamp turn OFF?

YES >> INSPECTION END

NO >> GO TO 3.

3. CHECK BCM

 **With CONSULT**

Perform "SELF-DIAG RESULTS" in "AIR PRESSURE MONITOR" of "BCM".

Is any DTC detected?

YES >> Check the DTC. Refer to [BCS-63, "DTC Index"](#).

NO >> GO TO 4.

4. CHECK BCM POWER SUPPLY AND GROUND CIRCUIT

Perform the trouble diagnosis for power supply and ground circuit. Refer to [WT-29, "Diagnosis Procedure"](#).

Is the inspection result normal?

YES >> Replace the BCM. Refer to [BCS-86, "Removal and Installation"](#).

NO >> Repair or replace error-detected parts.

LOW TIRE PRESSURE WARNING LAMP BLINKS

< SYMPTOM DIAGNOSIS >

LOW TIRE PRESSURE WARNING LAMP BLINKS

Description

INFOID:000000008379003

The low tire pressure warning lamp blinks when the ignition switch is turned ON.

NOTE:

The position of an inactive tire pressure sensor can be identified by checking the blinking timing of the low tire pressure warning lamp.

Low tire pressure warning lamp blinking timing		Activation tire position
ON OFF		a : 0.3 sec. b : 1.0 sec. Front LH
ON OFF		a : 0.3 sec. b : 1.0 sec. Front RH
ON OFF		a : 0.3 sec. b : 1.0 sec. Rear RH
ON OFF		a : 0.3 sec. b : 1.0 sec. Rear LH
ON OFF		a : 2 sec. b : 0.2 sec. All tires

JPEIC0089GB

Diagnosis Procedure

INFOID:000000008379004

1. TIRE PRESSURE SENSOR ID REGISTRATION

Perform tire pressure sensor ID registration. Refer to [WT-20, "Work Procedure"](#).

Is tire pressure sensor ID registration completed?

YES >> INSPECTION END

NO >> Perform the self-diagnosis for "AIR PRESSURE MONITOR". Refer to [BCS-63, "DTC Index"](#).

A
B
C
D
WT
F
G
H
I
J
K
L
M
N
O
P

EASY FILL TIRE ALERT DOES NOT ACTIVATE

< SYMPTOM DIAGNOSIS >

EASY FILL TIRE ALERT DOES NOT ACTIVATE

Description

INFOID:000000008379005

The easy fill tire alert does not function while inflating a tire when the select lever position is in P-range with the ignition switch ON.

NOTE:

- After starting to inflate the tire, it takes a few seconds for the easy fill tire alert to function.
- If there is no response for approximately 15 seconds or more after inflating the tires, cancel the use of the easy fill tire alert function or move the vehicle approximately 1 m (3.2 ft) backward or forward to try again. The air filler pressure may be weak or out of service area.
- For easy fill tire alert, Refer to [WT-9, "Easy Fill Tire Alert Function"](#).

Diagnosis Procedure

INFOID:000000008379006

1. LOCATION CHANGE

Move the vehicle to other area and repeat the procedure of the easy fill tire alert function. Refer to [WT-9, "Easy Fill Tire Alert Function"](#).

Is the function normal?

- YES >> Normal (the easy fill tire alert may not operate, depending on reception condition.)
NO >> GO TO 2.

2. PERFORM BCM SELF-DIAGNOSIS

With CONSULT

Perform self-diagnosis for "AIR PRESSURE MONITOR".

Is any DTC detected?

- YES >> Perform trouble diagnosis for detected DTC. Refer to [BCS-63, "DTC Index"](#).
NO >> GO TO 3.

3. CHECK HAZARD WARNING LAMP OPERATION

Check hazard warning lamp operation with hazard switch.

Does the hazard warning lamp blink?

- YES >> GO TO 4.
NO >> Perform trouble diagnosis for the hazard warning lamp. Refer to [EXL-73, "Diagnosis Procedure"](#) (XENON TYPE), [EXL-171, "Diagnosis Procedure"](#) (HALOGEN TYPE).

4. PERFORM TCM SELF-DIAGNOSIS

With CONSULT

Perform self-diagnosis for "TRANSMISSION".

Is any DTC detected?

- YES >> Check malfunctioning circuit. Refer to [TM-48, "DTC Index"](#).
NO >> GO TO 5.

5. CHECK HORN OPERATION

Check horn operation. Refer to [SEC-109, "Component Function Check"](#).

Is the operation normal?

- YES >> GO TO 6.
NO >> Repair or replace error-detected parts.

6. PERFORM BCM SELF-DIAGNOSIS

With CONSULT

1. Drive for 10 minutes at a speed of 40 km/h (25 MPH) or more.

CAUTION:

Total time driving at a speed of 40 km/h (25 MPH) or more must be 10 minutes.

2. Stop the vehicle.
3. Perform self-diagnosis for "AIR PRESSURE MONITOR".

Is any DTC detected?

EASY FILL TIRE ALERT DOES NOT ACTIVATE

< SYMPTOM DIAGNOSIS >

- YES >> Check malfunctioning circuit. Refer to [BCS-63. "DTC Index"](#).
- NO >> Replace BCM. Refer to [BCS-86. "Removal and Installation"](#).

- A
- B
- C
- D
- WT**
- F
- G
- H
- I
- J
- K
- L
- M
- N
- O
- P

TIRE PRESSURE SENSOR ID REGISTRATION CANNOT BE COMPLETED

< SYMPTOM DIAGNOSIS >

TIRE PRESSURE SENSOR ID REGISTRATION CANNOT BE COMPLETED

Description

INFOID:000000008379007

The ID of the tire pressure sensor installed in each wheel cannot be registered in the tire pressure monitoring system. Inspect the tire pressure sensor or the tire pressure monitoring system circuit.

Diagnosis Procedure

INFOID:000000008379008

1. CHECK TIRE PRESSURE SENSOR ACTIVATION TOOL

Check tire pressure sensor activation tool.

Is the inspection result normal?

YES >> GO TO 2.

NO >> Replace the battery of tire pressure sensor activation tool or repair/replace the tire pressure sensor activation tool.

2. TIRE PRESSURE SENSOR ID REGISTRATION

Perform tire pressure sensor ID registration. Refer to [WT-20, "Work Procedure"](#).

CAUTION:

To perform ID registration, observe the following points:

- Never register ID in a place where radio waves are interfered (e.g. radio tower).
- Never register ID in a place close to vehicles including TPMS.

Is tire pressure sensor ID registration completed?

YES >> INSPECTION END

NO >> GO TO 3.

3. CHECK TIRE PRESSURE SIGNAL

Change the work location and perform ID registration again.

NOTE:

Depending on the tire pressure sensor position*, a blind spot exists, and the tire pressure receiver gets a poor reception. If an ID registration is performed under this condition, the registration may not be completed. In such case, follow the instructions below to improve the radio wave receiving environment.

- Rotate tire by 90°, 180°, or 270°. (This Step is to change tire pressure sensor position.)
- Open the door close to the tire of which ID registration is ongoing.

*: Radio wave reception condition depends on vehicle architecture (e.g. body harness layout, tire wheel design) or environment.

When ID registration is performed, which wheels do not react?

All wheels react and ID registration is possible.>>INSPECTION END

Only certain wheel(s) do not react.>>Replace applicable tire pressure sensor. Refer to [WT-45, "Removal and Installation"](#).

All wheels do not react.>>Check the tire pressure receiver. Refer to [DLK-234, "Component Function Check"](#).

NOISE, VIBRATION AND HARSHNESS (NVH) TROUBLESHOOTING

< SYMPTOM DIAGNOSIS >

NOISE, VIBRATION AND HARSHNESS (NVH) TROUBLESHOOTING

NVH Troubleshooting Chart

INFOID:000000008379009

Use the chart below to find the cause of the symptom. If necessary, repair or replace these parts.

			WT-43, "Exploded View"	WT-43, "Inspection"	WT-40, "Wheel Balance Adjustment"	WT-48, "Tire Air Pressure"	WT-40, "Inspection"	—	—	WT-48, "Tire Air Pressure"	NVH in DLN section.	NVH in DLN section.	NVH in FAX and FSU sections.	NVH in RAX and RSU sections.	Refer to TIRE in this chart.	Refer to ROAD WHEEL in this chart.	NVH in FAX, RAX section.	NVH in BR section.	NVH in ST section.	
Reference																				
Possible cause and SUSPECTED PARTS			Improper installation, looseness	Out-of-round	Unbalance	Incorrect tire pressure	Uneven tire wear	Deformation or damage	Non-uniformity	Incorrect tire size	PROPELLER SHAFT	DIFFERENTIAL	FRONT AXLE AND FRONT SUSPENSION	REAR AXLE AND REAR SUSPENSION	TIRE	ROAD WHEELS	DRIVE SHAFT	BRAKE	STEERING	
Symptom	TIRE	Noise	x	x	x	x	x	x	x		x	x	x	x		x	x	x	x	
		Shake	x	x	x	x	x	x	x	x	x		x	x		x	x	x	x	
		Vibration				x					x	x		x	x			x		x
		Shimmy	x	x	x	x	x	x	x	x	x			x	x		x		x	x
		Judder	x	x	x	x	x	x			x			x	x		x		x	x
		Poor quality ride or handling	x	x	x	x	x	x			x			x		x	x			
	ROAD WHEEL	Noise	x	x	x			x				x	x	x	x	x		x	x	x
		Shake	x	x	x			x				x		x	x	x		x	x	x
		Shimmy, Judder	x	x	x			x						x	x	x			x	x
		Poor quality ride or handling	x	x	x			x						x	x	x				

x: Applicable

A
B
C
D
E
F
G
H
I
J
K
L
M
N
O
P

WT

ROAD WHEEL

< PERIODIC MAINTENANCE >

PERIODIC MAINTENANCE

ROAD WHEEL

Inspection

INFOID:000000008379010

APPEARANCE

Check the road wheel for bend, damage, crack or wear.

Wheel Balance Adjustment

INFOID:000000008379011

PREPARATION BEFORE ADJUSTMENT

Using releasing agent, remove double-faced adhesive tape from the road wheel.

CAUTION:

- Be careful not to scratch the road wheel during removal.
- After removing double-faced adhesive tape, wipe clean traces of releasing agent from the road wheel.

ADJUSTMENT (ALUMINUM WHEEL)

- The details of the adjustment procedure are different for each model of wheel balancer. Therefore, refer to each instruction manual.
- If a tire balance machine has adhesion balance weight mode settings and drive-in weight mode setting, select and adjust a drive-in weight mode suitable for aluminum wheels.

1. Set road wheel on tire balance machine using the center hole as a guide. Start the tire balance machine.
2. When inner and outer unbalance values are shown on the tire balance machine indicator, multiply outer unbalance value by $5/3$ to determine balance weight that should be used. Select the outer balance weight with a value closest to the calculated value above and install to the designated outer position of, or at the designated angle in relation to the road wheel.

CAUTION:

- Never install the inner balance weight before installing the outer balance weight.
- Before installing the balance weight, always clean the mating surface of the road wheel.

- a. Indicated unbalance value $\times 5/3$ = balance weight to be installed

Calculation example:

$23 \text{ g (0.81 oz)} \times 5/3 = 38.33 \text{ g (1.35 oz)} \Rightarrow 37.5 \text{ g (1.32 oz)}$ balance weight (closer to calculated balance weight value)

NOTE:

Note that balance weight value must be closer to the calculated balance weight value.

Example:

$36.2 \Rightarrow 35 \text{ g (1.23 oz)}$

$36.3 \Rightarrow 37.5 \text{ g (1.32 oz)}$

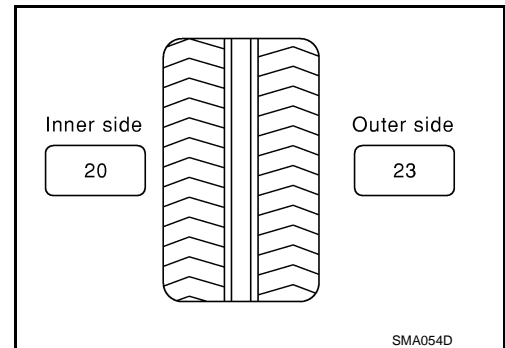

- b. Installed balance weight in the position.

ROAD WHEEL

< PERIODIC MAINTENANCE >

- When installing balance weight (1) to road wheels, set it into the grooved area (A) on the inner wall of the road wheel as shown in the figure so that the balance weight center (B) is aligned with the tire balance machine indication position (angle) (C).

CAUTION:

- Always use genuine NISSAN balance weights.
- Balance weights are non-reusable; always replace with new ones.
- Never install three or more sheets of balance weight.

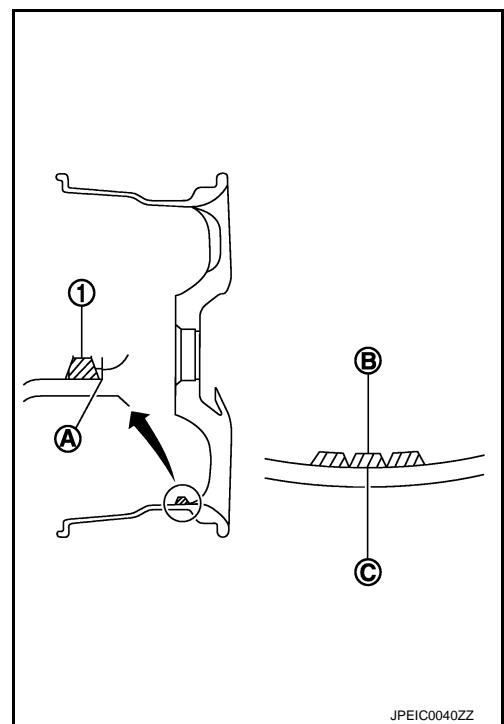

- c. If calculated balance weight value exceeds 50 g (1.76 oz), install two balance weight sheets in line with each other as shown in the figure.

CAUTION:

Never install one balance weight sheet on top of another.

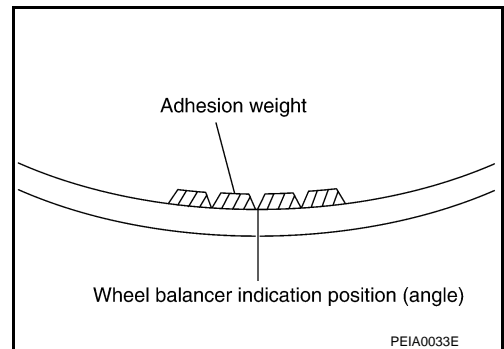

- Start the tire balance machine again.
 - Install drive-in balance weight on inner side of road wheel in the tire balance machine indication position (angle).
3. Start the tire balance machine again.
4. Install drive-in balance weight on inner side of road wheel in the tire balance machine indication position (angle).

CAUTION:

Never install three or more balance weight.

5. Start the tire balance machine. Check that the inner and outer residual unbalance value is within the allowable unbalance value.

CAUTION:

If either residual unbalance value exceeds limit, repeat installation procedures.

Allowable unbalance value

Dynamic (At flange) : Refer to [WT-48, "Road Wheel"](#).

Static (At flange) : Refer to [WT-48, "Road Wheel"](#).

ADJUSTMENT (STEEL WHEEL)

Preparation Before Adjustment

Remove balance weight from the road wheel.

Wheel Balance Adjustment

- The details of the adjustment procedure are different for each model of wheel balancer. Therefore, refer to each instruction manual.
- If a tire balance machine has adhesion balance weight mode settings and drive-in weight mode setting, select and adjust a drive-in weight mode suitable for steel wheels.

ROAD WHEEL

< PERIODIC MAINTENANCE >

1. Set road wheel to wheel balancer, and then start wheel balancer.
2. Install balance weight to road wheel according to the unbalance and position (angle) displayed on wheel balancer.
CAUTION:
 - Never install three or more balance weights on one side.
 - Always use genuine NISSAN balance weights.
 - Balance weights are non-reusable; always replace with new ones.
 - Always use a plastic hammer when attaching the weight.
3. Start the tire balance machine. Check that the inner and outer residual unbalance value is within the allowable unbalance value.
CAUTION:
If either residual unbalance value exceeds limit, repeat installation procedures.

Allowable unbalance value

Dynamic (At flange) : Refer to [WT-48, "Road Wheel"](#).

Static (At flange) : Refer to [WT-48, "Road Wheel"](#).

Tire Rotation

INFOID:000000008379012

- Follow the maintenance schedule for tire rotation service intervals. Refer to [MA-4, "Explanation of General Maintenance"](#).
- When installing the wheel, tighten wheel nuts to the specified torque. Refer to [WT-43, "Exploded View"](#).
CAUTION:
 - Never include the T-type spare tire when rotating the tires.
 - When installing wheels, tighten them diagonally by dividing the work two to three times in order to prevent the wheels from developing any distortion.
 - Be careful not to tighten wheel nut at torque exceeding the criteria.
 - Use NISSAN genuine wheel nut.
- Perform the ID registration, after tire rotation. Refer to [WT-20, "Work Procedure"](#).

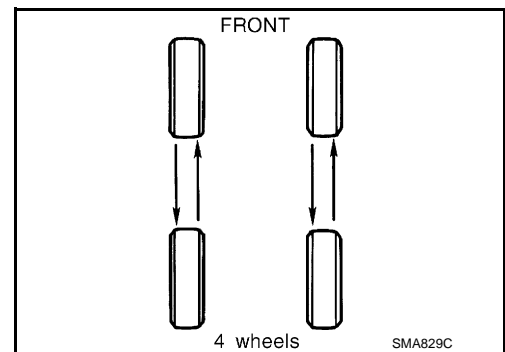

ROAD WHEEL TIRE ASSEMBLY

< REMOVAL AND INSTALLATION >

REMOVAL AND INSTALLATION

ROAD WHEEL TIRE ASSEMBLY

Exploded View

INFOID:000000008379013

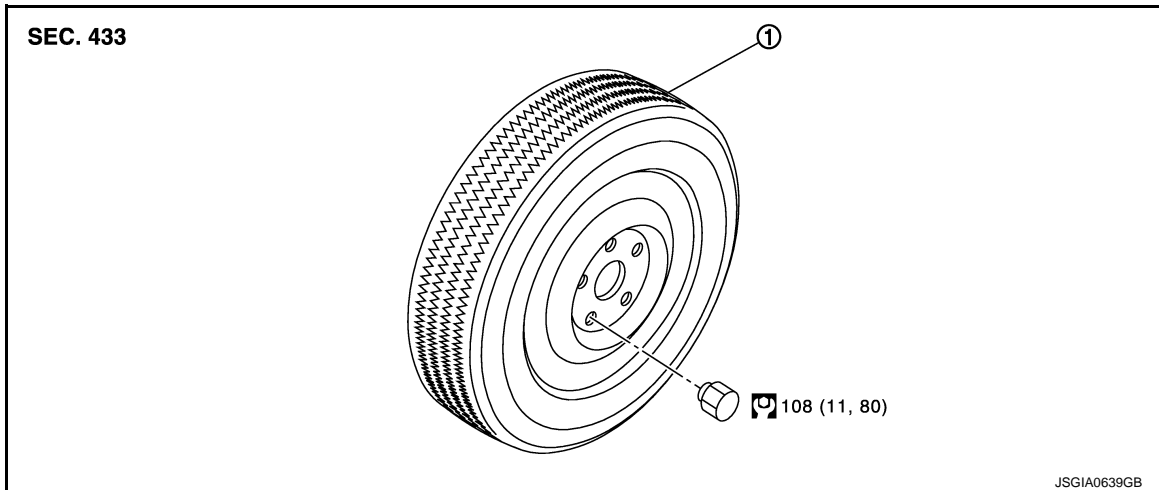

1. Tire assembly

: N·m (kg·m, ft·lb)

Removal and Installation

INFOID:000000008379014

REMOVAL

1. Remove wheel nuts.
2. Remove tire assembly.

INSTALLATION

Note the following, install in the reverse order of removal.

- When replacing or rotating wheels, perform the ID registration. Refer to [WT-20, "Work Procedure"](#).

Inspection

INFOID:000000008379015

ALUMINUM WHEEL

1. Check tires for wear and improper inflation.
2. Check wheels for deformation, cracks and other damage. If deformed, remove wheel and check wheel runout.
 - a. Remove tire from aluminum wheel and mount on a tire balance machine.
 - b. Set dial indicator as shown in the figure.
 - c. Check runout, if the axial runout (A) or radial runout (B) exceeds the limit, replace aluminum wheel.

Limit

Axial runout (A) : Refer to [WT-48, "Road Wheel"](#).

Radial runout (B) : Refer to [WT-48, "Road Wheel"](#).

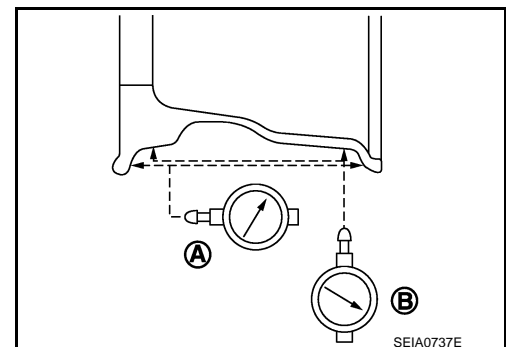

STEEL WHEEL

1. Check tires for wear and improper inflation.

ROAD WHEEL TIRE ASSEMBLY

< REMOVAL AND INSTALLATION >

2. Check wheels for deformation, cracks and other damage. If deformed, remove wheel and check wheel runout.
 - a. Remove tire from steel wheel and mount wheel on a tire balance machine.
 - b. Set two dial indicators as shown in the illustration.
 - c. Set each dial indicator to "0".
 - d. Rotate wheel and check dial indicators at several points around the circumference of the wheel.
 - e. Calculate runout at each point as shown below.

$$\text{Axial runout (A)} \quad : \quad (\textcircled{1} + \textcircled{2}) / 2$$

$$\text{Radial runout (B)} \quad : \quad (\textcircled{3} + \textcircled{4}) / 2$$

- f. Select maximum positive runout value and the maximum negative value. Add the two values to determine total runout.

CAUTION:

In case a positive or negative value is not available, use the maximum value (negative or positive) for total runout.

Limit

A : Refer to [WT-48, "Road Wheel"](#).

B : Refer to [WT-48, "Road Wheel"](#).

- g. If the total runout value exceeds limit, replace steel wheel.

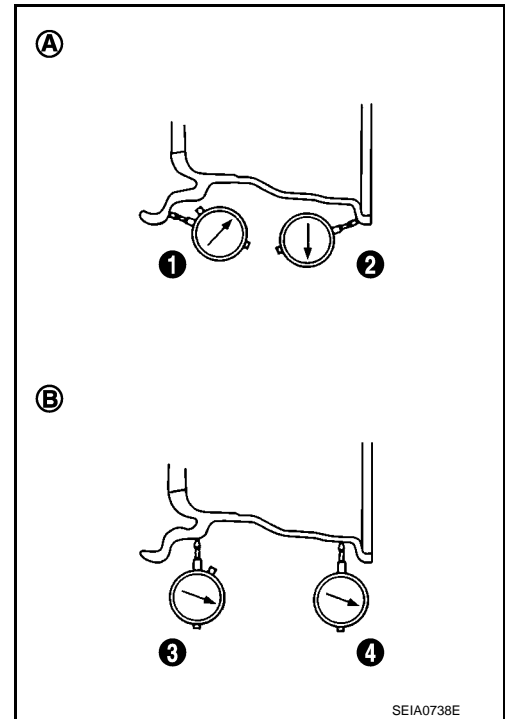

TIRE PRESSURE SENSOR

< REMOVAL AND INSTALLATION >

TIRE PRESSURE SENSOR

Exploded View

INFOID:000000008379016

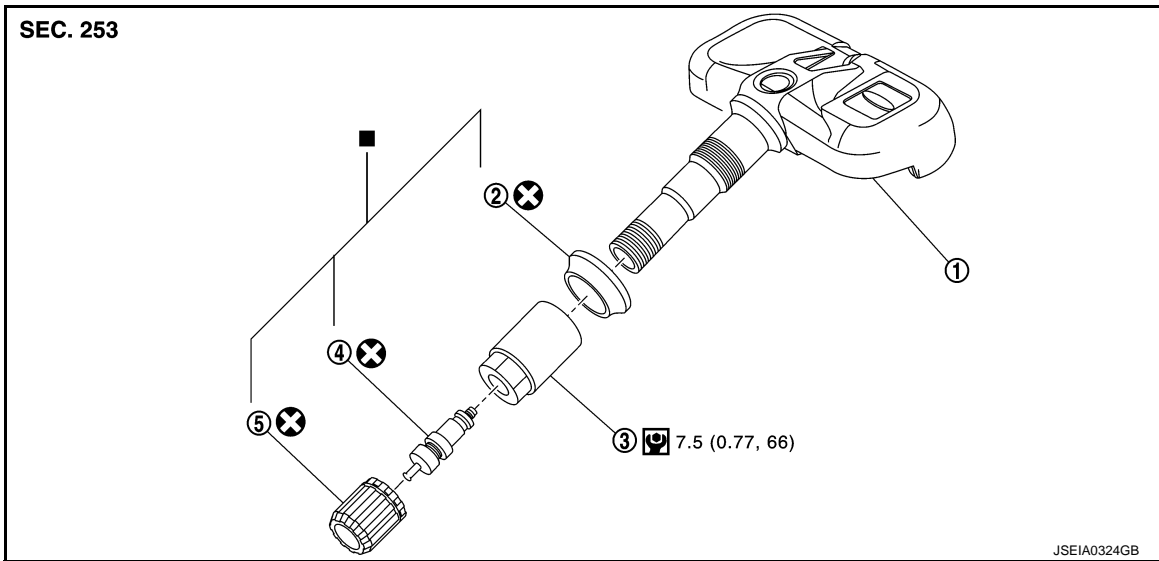

- | | | |
|-------------------------|-----------------|--------------|
| 1. Tire pressure sensor | 2. Grommet seal | 3. Valve nut |
| 4. Valve core | 5. Valve cap | |

: N·m (kg·m, in·lb)

: Always replace after every disassembly.

: Parts that are replaced as a set when the tire is replaced.

Removal and Installation

INFOID:000000008379017

REMOVAL

1. Remove tire assembly. Refer to [WT-43, "Removal and Installation"](#).
2. Remove valve cap, valve core and then deflate tire.

NOTE:

If the tire is reused, apply a matching mark to the position of the tire road wheel valve hole for the purpose of wheel balance adjustment after installation.

3. Remove valve nut retaining tire pressure sensor and allow tire pressure sensor to fall into tire.
4. Use the tire changer and disengage the tire beads.

CAUTION:

- Verify that the tire pressure sensor (1) is at the bottom of the tire while performing the above.
- Be sure not to damage the road wheel or tire pressure sensor.

5. Apply bead cream or an equivalent to the tire beads.
6. Set tire onto the tire changer turntable so that the tire pressure sensor inside the tire is located close to the road wheel valve hole.

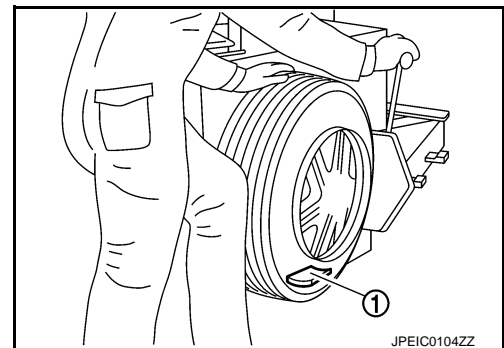

TIRE PRESSURE SENSOR

< REMOVAL AND INSTALLATION >

- Turn tire so that valve hole is at bottom and bounce so that tire pressure sensor (1) is near valve hole. Carefully lift tire onto turntable and position valve hole (and tire pressure sensor) 270 degree from mounting/dismounting head (2).

CAUTION:

Be sure not to damage the road wheel and tire pressure sensor.

- Remove tire pressure sensor from tire.
- Remove the grommet seal.

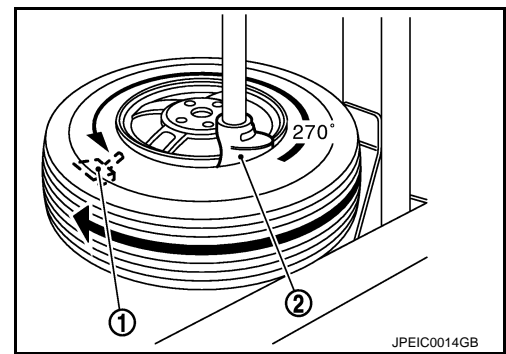

INSTALLATION

- Apply bead cream or an equivalent to the tire beads.
- Install the tire inside beads (1) onto the road wheel (2) in the position shown in the figure.
- Install grommet seal to the tire pressure sensor.

CAUTION:

- Never reuse grommet seal.
- Insert grommet seal all the way to the base.

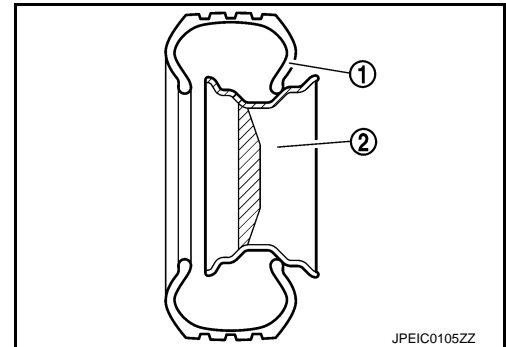

- Hold tire pressure sensor as shown in the figure, and press the sensor in the direction shown by arrow (←) to bring it into absolute contact with valve hole. After this, tighten valve nut to the specified torque.

CAUTION:

- Never reuse valve core and valve cap.
- Check that grommet seal is free of foreign matter.
- Check that grommet seal contacts horizontally with road wheel.
- Manually tighten valve nut all the way to the wheel. (Never use a power tool to avoid impact.)

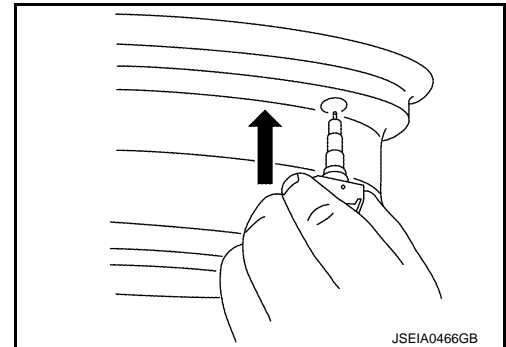

- Set the tire onto the turntable so that the tire changer arm (2) is at a position approximately 270° from the tire pressure sensor (1).

CAUTION:

Be sure that the arm does not contact the tire pressure sensor.

- Install the tire outer side beads onto the road wheel.

CAUTION:

When installing, check that the tire does not turn together with the road wheel.

- Check the tire pressure for all wheels and adjust to the specified value. Refer to [WT-48, "Tire Air Pressure"](#).

NOTE:

Before adding air, align the tire with the position of the matching mark applied at the time of removal.

- Install tire to the vehicle. Refer to [WT-43, "Removal and Installation"](#).
- Perform tire pressure sensor ID registration. Refer to [WT-20, "Work Procedure"](#).

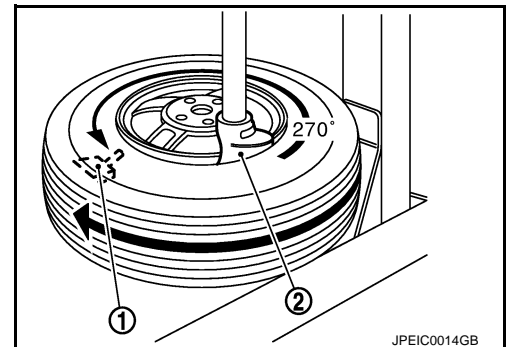

TIRE PRESSURE RECEIVER

< REMOVAL AND INSTALLATION >

TIRE PRESSURE RECEIVER

Removal and Installation

INFOID:000000008379018

REMOVAL

1. Remove the remote keyless entry receiver. (The tire pressure receiver is incorporated into remote keyless entry receiver.) Refer to [DLK-460, "Removal and Installation"](#).

INSTALLATION

Install in the reverse order of removal.

A

B

C

D

WT

F

G

H

I

J

K

L

M

N

O

P

SERVICE DATA AND SPECIFICATIONS (SDS)

< SERVICE DATA AND SPECIFICATIONS (SDS)

SERVICE DATA AND SPECIFICATIONS (SDS)

SERVICE DATA AND SPECIFICATIONS (SDS)

Road Wheel

INFOID:000000008379019

ALUMINUM WHEEL

Item		Limit
Runout	Axial runout	Less than 0.3 mm (0.012 in)
	Radial runout	
Allowable unbalance	Dynamic (At flange)	Less than 5 g (0.17 oz) (one side)
	Static (At flange)	Less than 10 g (0.35 oz)

STEEL WHEEL

Item		Limit
Runout	Axial runout (Average)	Less than 0.8 mm (0.031 in)
	Radial runout (Average)	Less than 0.5 mm (0.020 in)
Allowable unbalance	Dynamic (At flange)	Less than 5 g (0.17 oz) (one side)
	Static (At flange)	Less than 10 g (0.35 oz)

STEEL WHEEL (EMERGENCY)

Item		Limit
Runout	Axial runout (Average)	Less than 1.5 mm (0.059 in)
	Radial runout (Average)	

Tire Air Pressure

INFOID:000000008379020

Unit: kPa (kgf/cm², psi)

Item	Standard	
	Front	Rear
P225/65R16 99T	240 (2.4, 35)	
P235/55R18 99T	240 (2.4, 35)	
T135/80D16 101M	420 (4.2, 60)	
T135/90D16 102M		