

SECTION **INT**
INTERIOR

A
B
C

CONTENTS

D
E

PRECAUTION	3	Exploded View	20	F
PRECAUTIONS	3	FRONT PILLAR GARNISH	21	G
Precaution for Supplemental Restraint System (SRS) "AIR BAG" and "SEAT BELT PRE-TENSIONER"	3	FRONT PILLAR GARNISH : Removal and Installation	21	H
Precaution for Procedure without Cowl Top Cover.....	3	FRONT PILLAR LOWER GARNISH	22	I
Precautions for Removing Battery Terminal	4	FRONT PILLAR LOWER GARNISH : Removal and Installation	22	J
Precaution for Work	4	KICKING PLATE	22	K
PREPARATION	5	KICKING PLATE : Removal and Installation	22	L
PREPARATION	5	BODY SIDE WELT	23	M
Special Service Tools	5	BODY SIDE WELT : Removal and Installation	23	N
Commercial Service Tools	5	DASH SIDE FINISHER	24	O
CLIP LIST	6	DASH SIDE FINISHER : Removal and Installation	24	P
Clip List	6	CENTER PILLAR LOWER GARNISH	25	Q
SYMPTOM DIAGNOSIS	7	CENTER PILLAR LOWER GARNISH : Removal and Installation	25	R
SQUEAK AND RATTLE TROUBLE DIAGNOSES	7	CENTER PILLAR UPPER GARNISH	25	S
Work Flow	7	CENTER PILLAR UPPER GARNISH : Removal and Installation	26	T
Inspection Procedure	9	REAR PILLAR GARNISH	26	U
Diagnostic Worksheet	11	REAR PILLAR GARNISH : Removal and Installation	27	V
REMOVAL AND INSTALLATION	13	BACK PILLAR GARNISH	27	W
FRONT DOOR FINISHER	13	BACK PILLAR GARNISH : Removal and Installation	27	X
Exploded View	13	ROOF SIDE GARNISH	28	Y
Removal and Installation	14	ROOF SIDE GARNISH : Removal and Installation	28	Z
SLIDE DOOR FINISHER	16	FLOOR TRIM	30	AA
Exploded View	16	Exploded View	30	AB
Removal and Installation	17	FRONT FLOOR CARPET	30	AC
SECOND ROLL SUNSHADE	18			
SECOND ROLL SUNSHADE : Disassembly	18			
SECOND ROLL SUNSHADE : Disassembly and Assembly	18			
BODY SIDE TRIM	20			

INT

FRONT FLOOR CARPET : Removal and Installation	30	LUGGAGE SIDE LOWER FINISHER : Removal and Installation	43
REAR FLOOR CARPET	31	THIRD ROLL SUNSHADE	44
REAR FLOOR CARPET : Removal and Installation	31	THIRD ROLL SUNSHADE : Exploded View	44
HEADLINING	33	THIRD ROLL SUNSHADE : Disassembly and Assembly	45
Exploded View	33	LUGGAGE FLOOR BOX	45
Removal and Installation	35	LUGGAGE FLOOR BOX : Removal and Installation	45
LUGGAGE FLOOR TRIM	39	BACK DOOR TRIM	47
Exploded View	39	Exploded View	47
LUGGAGE FLOOR REAR BOARD	40	BACK DOOR PULL HANDLE	47
LUGGAGE FLOOR REAR BOARD : Removal and Installation	40	BACK DOOR PULL HANDLE : Removal and Installation	47
TAILGATE KICKING PLATE	40	BACK DOOR LOWER FINISHER	48
TAILGATE KICKING PLATE : Removal and Installation	40	BACK DOOR LOWER FINISHER : Removal and Installation	48
CABLE COVER	41	BACK DOOR UPPER FINISHER	49
CABLE COVER : Removal and Installation	41	BACK DOOR UPPER FINISHER : Removal and Installation	49
LUGGAGE FLOOR FRONT BOARD	42	BACK DOOR SIDE FINISHER	49
LUGGAGE FLOOR FRONT BOARD : Removal and Installation	42	BACK DOOR SIDE FINISHER : Removal and Installation	49
LUGGAGE FLOOR FRONT BRACKET	42	EMERGENCY LID	50
LUGGAGE FLOOR FRONT BRACKET : Removal and Installation	42	EMERGENCY LID : Removal and Installation	50
LUGGAGE SIDE LOWER FINISHER	43		

PRECAUTIONS

< PRECAUTION >

PRECAUTION

PRECAUTIONS

Precaution for Supplemental Restraint System (SRS) "AIR BAG" and "SEAT BELT PRE-TENSIONER"

INFOID:000000009650265

The Supplemental Restraint System such as "AIR BAG" and "SEAT BELT PRE-TENSIONER", used along with a front seat belt, helps to reduce the risk or severity of injury to the driver and front passenger for certain types of collision. This system includes seat belt switch inputs and dual stage front air bag modules. The SRS system uses the seat belt switches to determine the front air bag deployment, and may only deploy one front air bag, depending on the severity of a collision and whether the front occupants are belted or unbelted. Information necessary to service the system safely is included in the "SRS AIR BAG" and "SEAT BELT" of this Service Manual.

WARNING:

Always observe the following items for preventing accidental activation.

- To avoid rendering the SRS inoperative, which could increase the risk of personal injury or death in the event of a collision that would result in air bag inflation, all maintenance must be performed by an authorized NISSAN/INFINITI dealer.
- Improper maintenance, including incorrect removal and installation of the SRS, can lead to personal injury caused by unintentional activation of the system. For removal of Spiral Cable and Air Bag Module, see "SRS AIR BAG".
- Never use electrical test equipment on any circuit related to the SRS unless instructed to in this Service Manual. SRS wiring harnesses can be identified by yellow and/or orange harnesses or harness connectors.

PRECAUTIONS WHEN USING POWER TOOLS (AIR OR ELECTRIC) AND HAMMERS

WARNING:

Always observe the following items for preventing accidental activation.

- When working near the Air Bag Diagnosis Sensor Unit or other Air Bag System sensors with the ignition ON or engine running, never use air or electric power tools or strike near the sensor(s) with a hammer. Heavy vibration could activate the sensor(s) and deploy the air bag(s), possibly causing serious injury.
- When using air or electric power tools or hammers, always switch the ignition OFF, disconnect the battery, and wait at least 3 minutes before performing any service.

Precaution for Procedure without Cowl Top Cover

INFOID:000000009650266

When performing the procedure after removing cowl top cover, cover the lower end of windshield with urethane, etc to prevent damage to windshield.

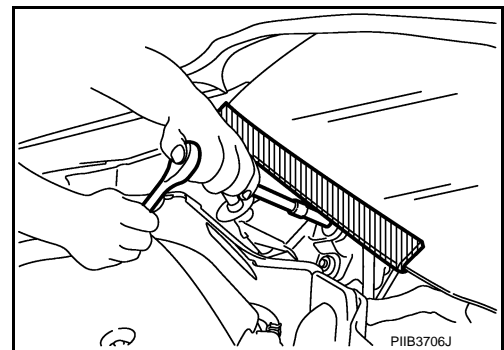

PRECAUTIONS

< PRECAUTION >

Precautions for Removing Battery Terminal

INFOID:000000009880523

- When removing the 12V battery terminal, turn OFF the ignition switch and wait at least 30 seconds.

NOTE:

ECU may be active for several tens of seconds after the ignition switch is turned OFF. If the battery terminal is removed before ECU stops, then a DTC detection error or ECU data corruption may occur.

- For vehicles with the 2-batteries, be sure to connect the main battery and the sub battery before turning ON the ignition switch.

NOTE:

If the ignition switch is turned ON with any one of the terminals of main battery and sub battery disconnected, then DTC may be detected.

- After installing the 12V battery, always check "Self Diagnosis Result" of all ECUs and erase DTC.

NOTE:

The removal of 12V battery may cause a DTC detection error.

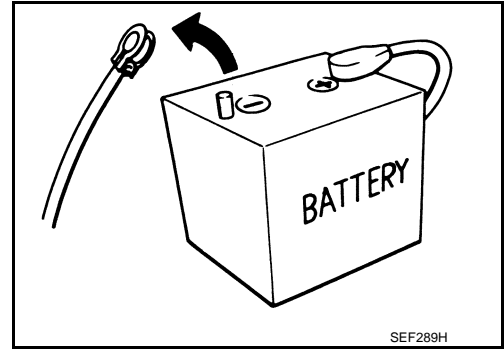

Precaution for Work

INFOID:000000009650267

- After removing and installing the opening/closing parts, be sure to carry out fitting adjustments to check their operation.
- Check the lubrication level, damage, and wear of each part. If necessary, grease or replace it.

PREPARATION

< PREPARATION >

PREPARATION

PREPARATION

Special Service Tools

INFOID:000000009650268

The actual shapes of Kent-Moore tools may differ from those of special service tools illustrated here.

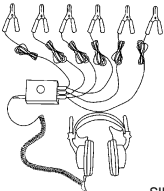
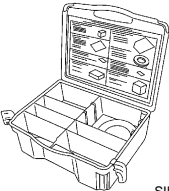
Tool number (Kent-Moore No.) Tool name	Description
(J-39570) Chassis ear  SIIA0993E	Locates the noise
(J-50397) NISSAN Squeak and Rattle Kit  SIIA0994E	Repairs the cause of noise

Commercial Service Tools

INFOID:000000009650269

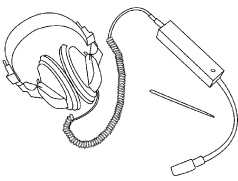
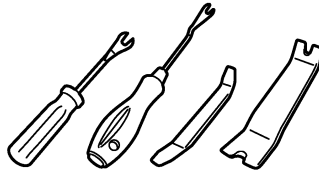
Tool name	Description
Engine ear  SIIA0995E	Locates the noise
Remover tool  JMKIA3050ZZ	Removes clips, pawls and metal clips

CLIP LIST

< PREPARATION >

CLIP LIST

Clip List

INFOID:00000009650270

Shapes	Removal & Installation	Shapes	Removal & Installation
	<p>Removal: Remove by bending up with flat-bladed screwdrivers or clip remover.</p>		<p>Removal:</p>
	<p>Removal: Remove with a clip remover.</p>		<p>Removal:</p>
	<p>Removal: Push center pin to catching position. (Do not remove center pin by hitting it.)</p> <p>Installation:</p>		<p>Removal: Holder portion of clip must be spread out to remove rod.</p>
	<p>Removal: Remove by bending up with flat-bladed screwdrivers or clip remover.</p>		<p>Removal:</p> <ol style="list-style-type: none"> Screw out with a Phillips screwdriver. Remove female portion with flat-bladed screwdriver.
	<p>Removal:</p>		<p>Removal:</p> <p>Rotate 45° to remove.</p> <p>Installation:</p>
	<p>Removal:</p>		<p>Removal:</p>

JMJIA3734GB

SQUEAK AND RATTLE TROUBLE DIAGNOSES

< SYMPTOM DIAGNOSIS >

SYMPTOM DIAGNOSIS

SQUEAK AND RATTLE TROUBLE DIAGNOSES

Work Flow

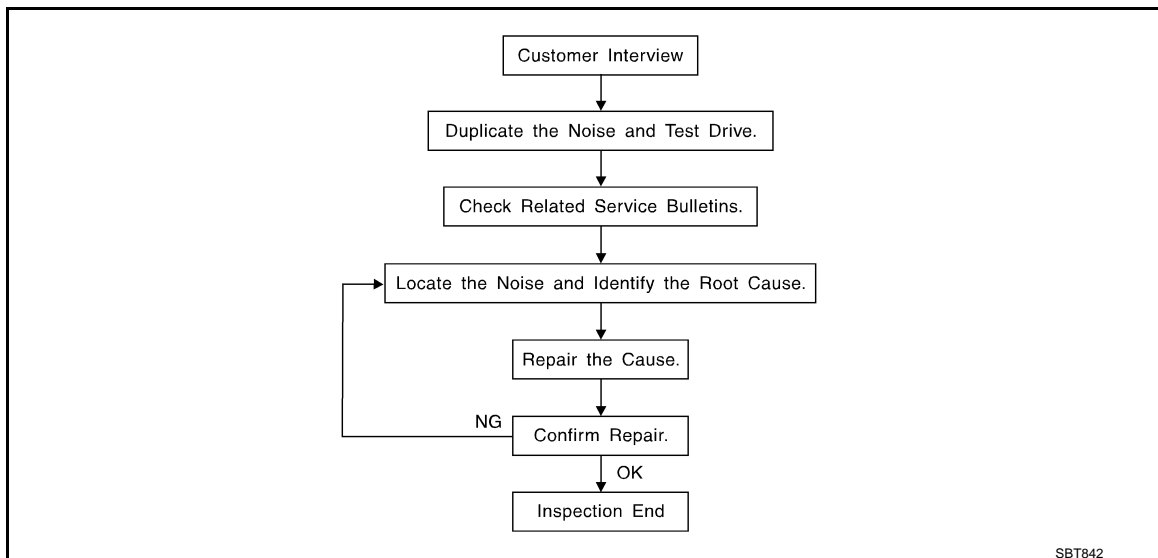

CUSTOMER INTERVIEW

Interview the customer if possible, to determine the conditions that exist when the noise occurs. Use the Diagnostic Worksheet during the interview to document the facts and conditions when the noise occurs and any customer comments. Refer to [INT-11, "Diagnostic Worksheet"](#). This information is necessary to duplicate the conditions that exist when the noise occurs.

- The customer may not be able to provide a detailed description or the location of the noise. Attempt to obtain all the facts and conditions that exist when the noise occurs (or does not occur).
- If there is more than one noise in the vehicle, perform a diagnosis and repair the noise that the customer is concerned about. This can be accomplished by performing a test drive with the customer.
- After identifying the type of noise, isolate the noise in terms of its characteristics. The noise characteristics are provided so that the customer, service adviser, and technician use the same language when describing the noise.
- Squeak – (Like tennis shoes on a clean floor)
Squeak characteristics include the light contact / fast movement / brought on by road conditions / hard surfaces = high-pitched noise / softer surfaces = low-pitched noises / edge to surface = chirping
- Creak – (Like walking on an old wooden floor)
Creak characteristics include firm contact / slow movement/twisting with a rotational movement / pitch dependent on materials / often brought on by activity.
- Rattle – (Like shaking a baby rattle)
Rattle characteristics include fast repeated contact / vibration or similar movement / loose parts/missing clip or fastener / incorrect clearance.
- Knock – (Like a knock on a door)
Knock characteristics include hollow sounds / sometimes repeating / often brought on by driver action.
- Tick – (Like a clock second hand)
Tick characteristics include gentle contacting of light materials / loose components / can be caused by driver action or road conditions.
- Thump – (Heavy, muffled knock noise)
Thump characteristics include softer knock / dull sounds often brought on by activity.
- Buzz – (Like a bumblebee)
Buzz characteristics include high frequency rattle / firm contact.
- Often the degree of acceptable noise level varies depending upon the person. A noise that a technician may judge as acceptable may be very irritating to a customer.
- Weather conditions, especially humidity and temperature, may have a great effect on noise level.

DUPLICATE THE NOISE AND TEST DRIVE

SQUEAK AND RATTLE TROUBLE DIAGNOSES

< SYMPTOM DIAGNOSIS >

If possible, drive the vehicle with the customer until the noise is duplicated. Note any additional information on the Diagnostic Worksheet regarding the conditions or location of the noise. This information can be used to duplicate the same conditions when the repair is reconfirmed.

If the noise can be duplicated easily during the test drive, do the following with the vehicle stopped to help identify the source of the noise.

- 1) Close a door.
 - 2) Tap or push/pull around the area where the noise appears to be coming from.
 - 3) Rev the engine.
 - 4) Use a floor jack to recreate vehicle "twist".
 - 5) At idle, apply engine load (electrical load, half-clutch on M/T models, drive position on A/T models).
 - 6) Raise the vehicle on a hoist and hit a tire with a rubber hammer.
- Drive the vehicle and attempt to duplicate the conditions the customer states exist when the noise occurs.
 - If it is difficult to duplicate the noise, drive the vehicle slowly on an undulating or rough road to stress the vehicle body.

CHECK RELATED SERVICE BULLETINS

After verifying the customer concern or symptom, check ASIST for Technical Service Bulletins (TSBs) related to the concern or symptom.

If a TSB relates to the symptom, follow the procedure to repair the noise.

LOCATE THE NOISE AND IDENTIFY THE ROOT CAUSE

1. Narrow down the noise to a general area. To help pinpoint the source of the noise, use a listening tool (Chassis ear: J-39570, engine ear, and mechanics stethoscope).
2. Narrow down the noise to a more specific area and identify the cause of the noise by:
 - Removing the component(s) in the area(s) that is / are suspected to be the cause of the noise. Do not use too much force when removing clips and fasteners, otherwise clips and fasteners can be broken or lost during the repair, creating a new noise.
 - Tapping or pushing/pulling the component(s) that is / are suspected to be the cause of the noise. Do not tap or push/pull the component(s) with excessive force, otherwise the noise is eliminated only temporarily.
 - Feeling for a vibration by hand by touching the component(s) that is / are suspected to be the cause of the noise.
 - Placing a piece of paper between components that are suspected to be the cause of the noise.
 - Looking for loose components and contact marks.
Refer to [INT-9, "Inspection Procedure"](#).

REPAIR THE CAUSE

- If the cause is a loose component, tighten the component securely.
- If the cause is insufficient clearance between components:
 - Separate components by repositioning or loosening and retightening the components, if possible.
 - Insulate components with a suitable insulator such as urethane pads, foam blocks, felt cloth tape, or urethane tape. A NISSAN Squeak and Rattle Kit (J-50397) is available through the authorized NISSAN Parts Department.

CAUTION:

Never use excessive force as many components are constructed of plastic and may be damaged.

NOTE:

Always check with the Parts Department for the latest parts information.

The following materials are contained in the NISSAN Squeak and Rattle Kit (J-50397) are listed on the inside cover of the kit; and can each be ordered separately as needed.

URETHANE PADS [1.5 mm (0.059 in) thick]

Insulates connectors, harness, etc.

- 76268-9E005: 100 × 135 mm (3.937 × 5.315 in)
- 76884-71L01: 60 × 85 mm (2.362 × 3.346 in)
- 76884-71L02: 15 × 25 mm (0.591 × 0.984 in)

INSULATOR (Foam blocks)

Insulates components from contact. Can be used to fill space behind a panel.

- 73982-9E000: 45 mm (1.772 in) thick, 50 × 50 mm (1.969 × 1.969 in)
- 73982-50Y00: 10 mm (0.394 in) thick, 50 × 50 mm (1.969 × 1.969 in)

INSULATOR (Light foam block)

80845-71L00: 30 mm (1.18 in) thick, 30 × 50 mm (1.181 × 1.969 in)

FELT CLOTHTAPE

SQUEAK AND RATTLE TROUBLE DIAGNOSES

< SYMPTOM DIAGNOSIS >

Used to insulate where movement does not occur. Ideal for instrument panel applications.

- 68370-4B000: 15 × 25 mm (0.591 × 0.984 in) pad
- 68239-13E00: 5 mm (0.197 in) wide tape roll

The following materials, not found in the kit, can also be used to repair squeaks and rattles.

UHMW (TEFLON) TAPE

Insulates where slight movement is present. Ideal for instrument panel applications.

SILICONE GREASE

Used in place of UHMW tape that is visible or does not fit. Only lasts a few months.

SILICONE SPRAY

Used when grease cannot be applied.

DUCT TAPE

Used to eliminate movement.

CONFIRM THE REPAIR

After repair is complete, test drive the vehicle to confirm that the cause of noise is repaired by test driving the vehicle. Operate the vehicle under the same conditions as when the noise originally occurred. Refer to the notes on the Diagnostic Worksheet.

Inspection Procedure

INFOID:000000009650272

Refer to Table of Contents for specific component removal and installation information.

INSTRUMENT PANEL

Most incidents are caused by contact and movement between:

1. The cluster lid A and instrument panel
2. Acrylic lens and combination meter housing
3. Instrument panel to front pillar garnish
4. Instrument panel to windshield
5. Instrument panel mounting pins
6. Wiring harnesses behind the combination meter
7. A/C defroster duct and duct joint

These incidents can usually be located by tapping or moving the components to duplicate the noise or by pressing on the components while driving to stop the noise. Most of these incidents can be repaired by applying felt cloth tape or silicon spray (in hard to reach areas). Urethane pads can be used to insulate wiring harness.

CAUTION:

Never use silicone spray to isolate a squeak or rattle. If the area is saturated with silicone, the recheck of repair becomes impossible.

CENTER CONSOLE

Components to check include:

1. Shifter assembly cover to finisher
2. A/C control unit and cluster lid C
3. Wiring harnesses behind audio and A/C control unit

The instrument panel repair and isolation procedures also apply to the center console.

DOORS

Check the following items:

1. Finisher and inner panel making a slapping noise
2. Inside handle escutcheon connection to door finisher
3. Wiring harnesses tapping
4. Door striker out of alignment causing a popping noise on starts and stops

Tapping, moving the components, or pressing on them while driving to duplicate the conditions can isolate many of these incidents. The areas can usually be insulated with felt cloth tape or insulator foam blocks from the NISSAN Squeak and Rattle Kit (J-50397) to repair the noise.

TRUNK

Trunk noises are often caused by a loose jack or loose items put into the trunk by the customer.

In addition check for the following items:

A

B

C

D

E

F

G

H

I

INT

K

L

M

N

O

P

SQUEAK AND RATTLE TROUBLE DIAGNOSES

< SYMPTOM DIAGNOSIS >

1. Trunk lid dumpers out of adjustment
2. Trunk lid striker out of adjustment
3. Trunk lid torsion bars knocking together
4. A loose license plate or bracket

Most of these incidents can be repaired by adjusting, securing, or insulating the item(s) or component(s) causing the noise.

SUNROOF/HEADLINING

Noises in the sunroof / headlining area can often be traced to one of the following items:

1. Sunroof lid, rail, linkage, or seals making a rattle or light knocking noise
2. Sunvisor shaft shaking in the holder
3. Front or rear windshield touching headlining and squeaking

Again, pressing on the components to stop the noise while duplicating the conditions can isolate most of these incidents. Repairs usually consist of insulating with felt cloth tape.

SEATS

When isolating seat noise it is important to note the position the seat is in and the load placed on the seat when the noise occurs. These conditions should be duplicated when verifying and isolating the cause of the noise.

Causes of seat noise include:

1. Headrest rods and holder
2. A squeak between the seat pad cushion and frame
3. The rear seatback lock and bracket

These noises can be isolated by moving or pressing on the suspected components while duplicating the conditions under which the noise occurs. Most of these incidents can be repaired by repositioning the component or applying urethane tape to the contact area.

UNDERHOOD

Some interior noise may be caused by components under the hood or on the engine wall. The noise is then transmitted into the passenger compartment.

Causes of transmitted underhood noise include:

1. Any component mounted to the engine wall
2. Components that pass through the engine wall
3. Engine wall mounts and connectors
4. Loose radiator mounting pins
5. Hood bumpers out of adjustment
6. Hood striker out of adjustment

These noises can be difficult to isolate since they cannot be reached from the interior of the vehicle. The best method is to secure, move, or insulate one component at a time and test drive the vehicle. Also, engine RPM or load can be changed to isolate the noise. Repairs can usually be made by moving, adjusting, securing, or insulating the component causing the noise.

SQUEAK AND RATTLE TROUBLE DIAGNOSES

< SYMPTOM DIAGNOSIS >

Diagnostic Worksheet

INFOID:000000009650273



SQUEAK & RATTLE DIAGNOSTIC WORKSHEET

Dear Nissan Customer:

We are concerned about your satisfaction with your Nissan vehicle. Repairing a squeak or rattle sometimes can be very difficult. To help us fix your Nissan right the first time, please take a moment to note the area of the vehicle where the squeak or rattle occurs and under what conditions. You may be asked to take a test drive with a service advisor or technician to ensure we confirm the noise you are hearing.

I. WHERE DOES THE NOISE COME FROM? (circle the area of the vehicle)

The illustrations are for reference only, and may not reflect the actual configuration of your vehicle.

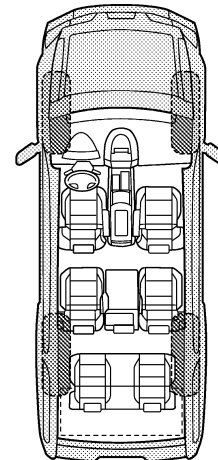
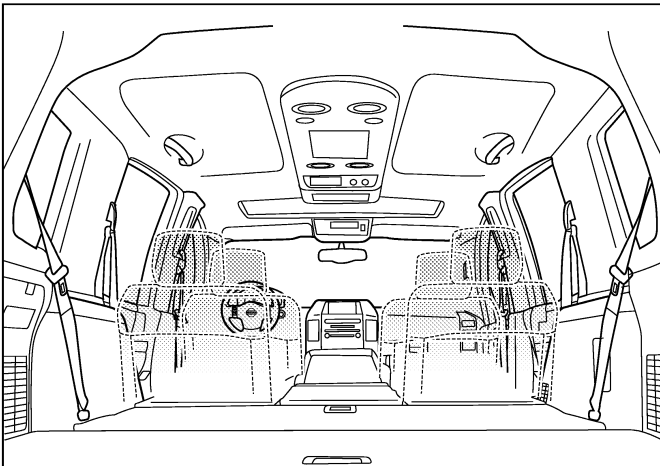
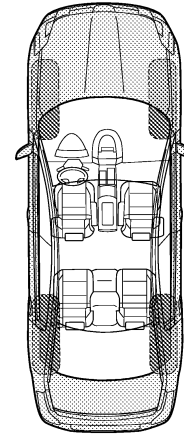
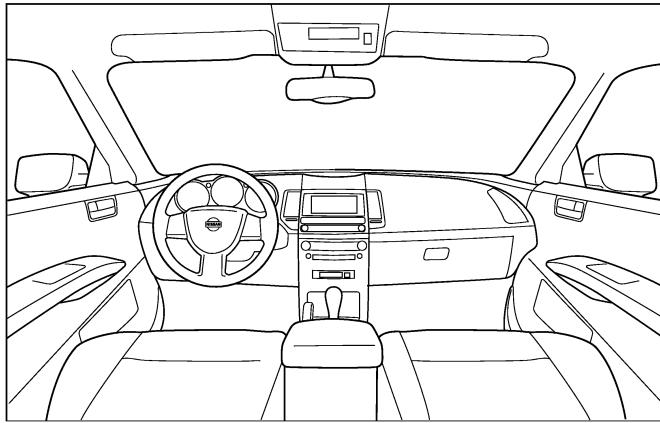

Continue to page 2 of the worksheet and briefly describe the location of the noise or rattle. In addition, please indicate the conditions which are present when the noise occurs.

PIIB8740E

A
B
C
D
E
F
G
H
I
INT
K
L
M
N
O
P

SQUEAK AND RATTLE TROUBLE DIAGNOSES

< SYMPTOM DIAGNOSIS >

SQUEAK & RATTLE DIAGNOSTIC WORKSHEET - page 2

Briefly describe the location where the noise occurs:

II. WHEN DOES IT OCCUR? (please check the boxes that apply)

- | | |
|---|--|
| <input type="checkbox"/> anytime | <input type="checkbox"/> after sitting out in the rain |
| <input type="checkbox"/> 1st time in the morning | <input type="checkbox"/> when it is raining or wet |
| <input type="checkbox"/> only when it is cold outside | <input type="checkbox"/> dry or dusty conditions |
| <input type="checkbox"/> only when it is hot outside | <input type="checkbox"/> other: |

III. WHEN DRIVING:

- through driveways
- over rough roads
- over speed bumps
- only about ____ mph
- on acceleration
- coming to a stop
- on turns: left, right or either (circle)
- with passengers or cargo
- other: _____
- after driving ____ miles or ____ minutes

IV. WHAT TYPE OF NOISE

- squeak (like tennis shoes on a clean floor)
- creak (like walking on an old wooden floor)
- rattle (like shaking a baby rattle)
- knock (like a knock at the door)
- tick (like a clock second hand)
- thump (heavy, muffled knock noise)
- buzz (like a bumble bee)

TO BE COMPLETED BY DEALERSHIP PERSONNEL

Test Drive Notes:

	YES	NO	Initials of person performing
Vehicle test driven with customer	<input type="checkbox"/>	<input type="checkbox"/>	_____
- Noise verified on test drive	<input type="checkbox"/>	<input type="checkbox"/>	_____
- Noise source located and repaired	<input type="checkbox"/>	<input type="checkbox"/>	_____
- Follow up test drive performed to confirm repair	<input type="checkbox"/>	<input type="checkbox"/>	_____

VIN: _____ Customer Name: _____
W.O.# _____ Date: _____

This form must be attached to Work Order

PIIB8742E

FRONT DOOR FINISHER

< REMOVAL AND INSTALLATION >

REMOVAL AND INSTALLATION

FRONT DOOR FINISHER

Exploded View

INFOID:000000009650274

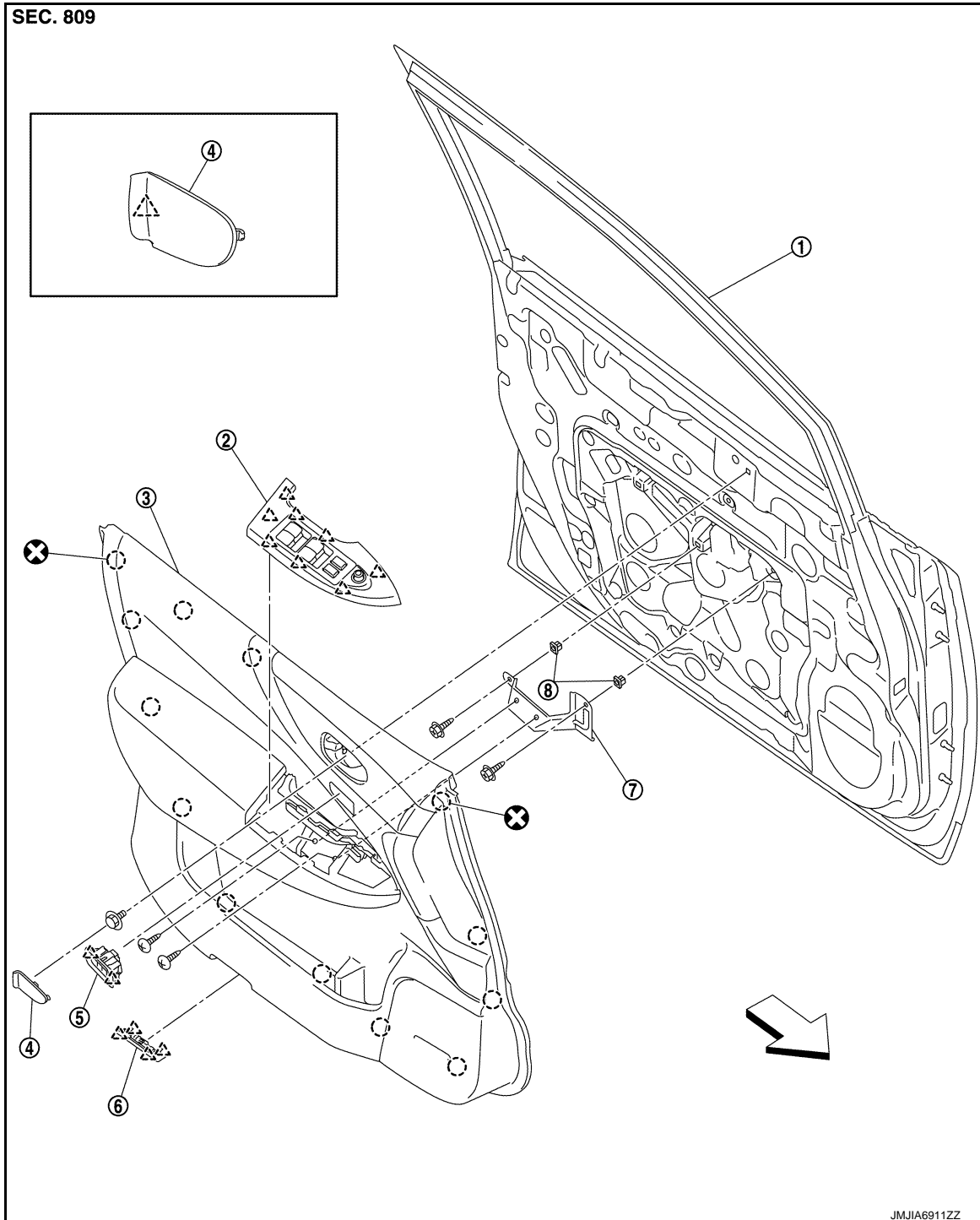

- | | | |
|-----------------------------|---------------------------------|------------------------|
| 1. Front door panel | 2. Power window switch finisher | 3. Front door finisher |
| 4. Inside handle escutcheon | 5. Seat memory switch finisher | 6. Step lamp |
| 7. Pull handle bracket | 8. Grommet | |

○ : Clip

A
B
C
D
E
F
G
H
I
INT
K
L
M
N
O
P

FRONT DOOR FINISHER

< REMOVAL AND INSTALLATION >

 : Pawl

 : Vehicle front

 : Always replace after every disassembly.

Removal and Installation

INFOID:000000009650275

CAUTION:

- When removing, always use a remover tool that is made of plastic to prevent damage to the parts.
- Never damage the front door panel.

REMOVAL

1. Remove inside handle escutcheon.
Pull inside handle forward, and then disengage pawls using a remover tool (A). Remove inside handle escutcheon.

 : Pawl

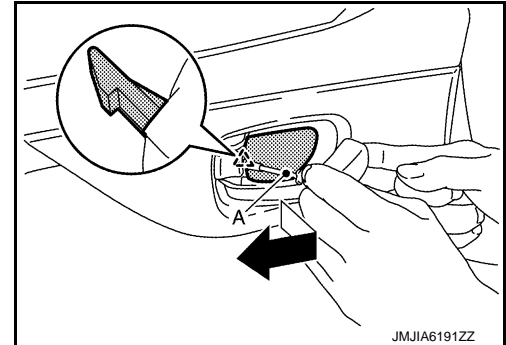

2. Remove bolt located on the back side of inside handle escutcheon.
3. Remove seat memory switch finisher and seat memory switch as a set (with personal driving position memory system).
- a. Disengage seat memory switch finisher fixing pawls using a remover tool (A).

CAUTION:

Apply protective tape (B) on the part to protect it from damage.

 : Pawl

- b. Pull out seat memory switch finisher and seat memory switch as a set, and then disconnect harness connector. Remove seat memory switch finisher and seat memory switch as a set.

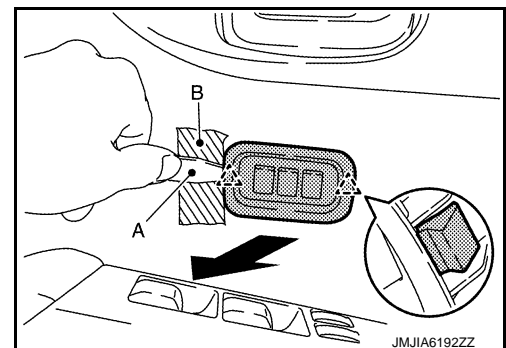

4. Remove power window switch finisher and power window switch as a set.

- a. Remove power window switch finisher fixing pawls using a remover tool (A).

CAUTION:

Apply protective tape (B) on the part to protect it from damage.

 : Pawl

- b. Disconnect harness connector, and then remove power window switch finisher and power window switch as a set.

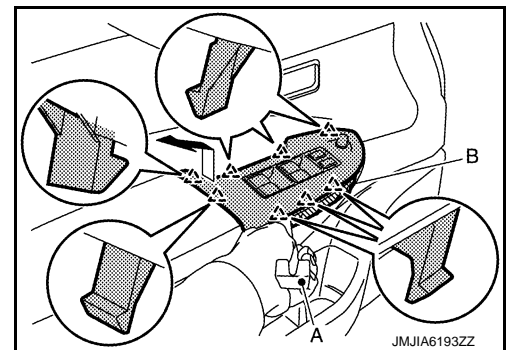

FRONT DOOR FINISHER

< REMOVAL AND INSTALLATION >

5. Remove front door finisher fixing screws (A).

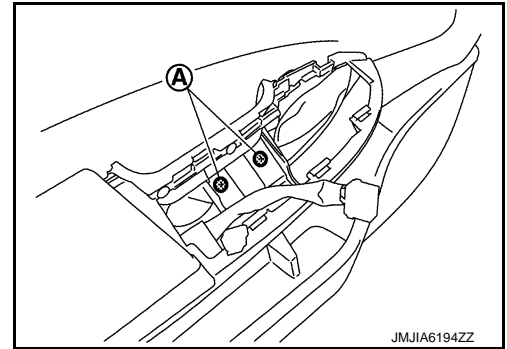

6. Remove step lamp assembly. Refer to [INL-75, "Removal and Installation"](#).
7. Remove front door finisher.

- a. Disengage fixing clips using a remover tool (A), and then pull out front door finisher.

CAUTION:

Insert a remover tool between door panel and clip and disengage pawl.

 : Clip

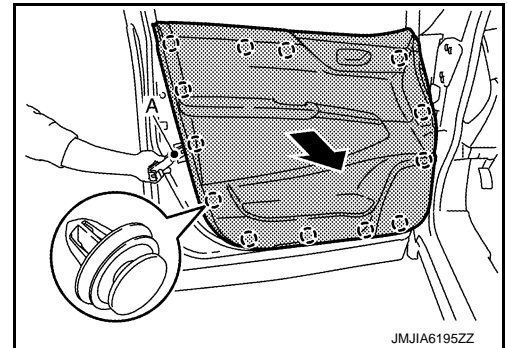

- b. Disconnect lock knob cable (1) and inside handle cable (2), and then remove front door finisher.

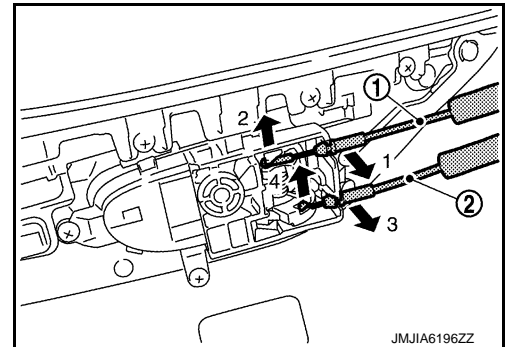

NOTE:

- Remove seat memory switch. Refer to [ADP-113, "Removal and Installation"](#).
- Remove power window switch.
Front window anti-pinch. Refer to [PWC-68, "Removal and Installation"](#).
Driver side window anti-pinch. Refer to [PWC-123, "Removal and Installation"](#).

INSTALLATION

Note the following item, and install in the reverse order of removal.

CAUTION:

- **One of the front door finisher fixing clips is not reusable. Always replace that clip after every front door finisher disassembly. Refer to [INT-13, "Exploded View"](#).**
- **When installing, check in advance that clips are accurately aligned with the holes on door panel side, and then install by pressing in.**

SLIDE DOOR FINISHER

< REMOVAL AND INSTALLATION >

SLIDE DOOR FINISHER

Exploded View

INFOID:000000009650276

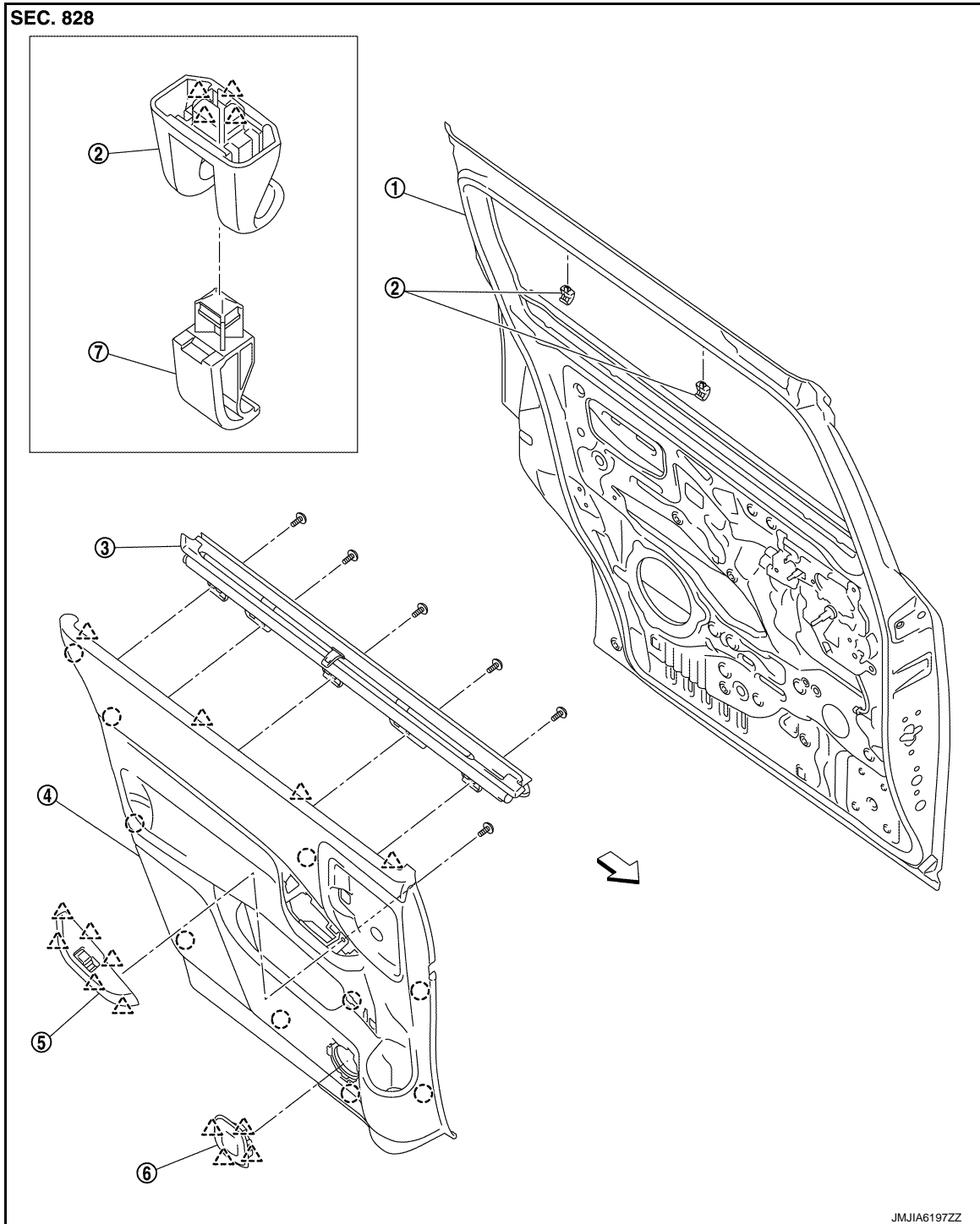

- | | | |
|-----------------------|---------------------------------|---|
| 1. Rear door panel | 2. Shade hook | 3. Second roll sunshade assembly (with roll sunshade) |
| 4. Side door finisher | 5. Power window switch finisher | 6. Speaker grille |
| 7. Hook pin | | |

○ : Clip

JMJIA6197ZZ

SLIDE DOOR FINISHER

< REMOVAL AND INSTALLATION >

 : Pawl

 : Vehicle front

Removal and Installation

INFOID:000000009650277

CAUTION:

- When removing, always use a remover tool that is made of plastic to prevent damage to the parts.
- Never damage the slide door panel.

REMOVAL

1. Fully open slide door.
2. Disengage fixing clips (B) on rear portion of door finisher using a remover tool (A).

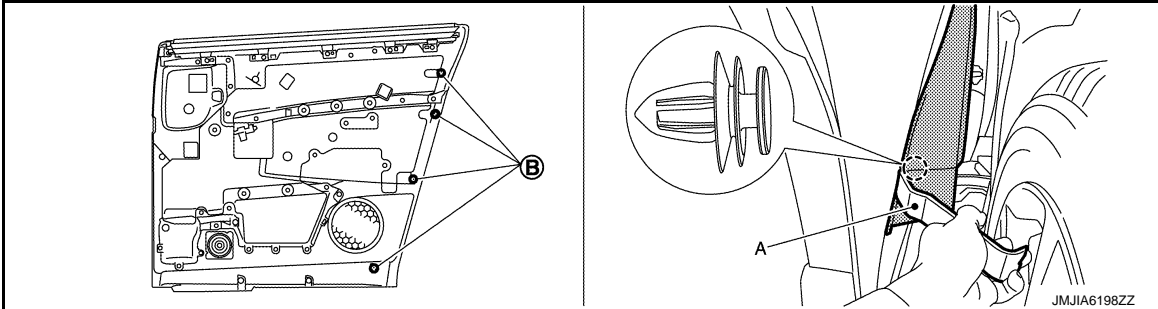

 : Clip

3. Remove slide door inside handle. Refer to [DLK-471, "INSIDE HANDLE : Removal and Installation"](#).
4. Disengage remaining fixing clips (B) using a remover tool (A).

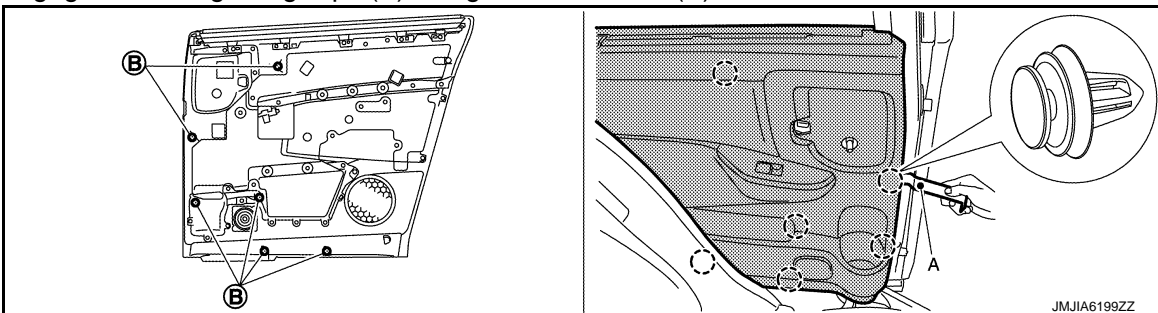

 : Clip

5. Pull toward the direction of the arrows as shown in the figure to remove.
6. Disconnect harness connector, and then remove slide door finisher.

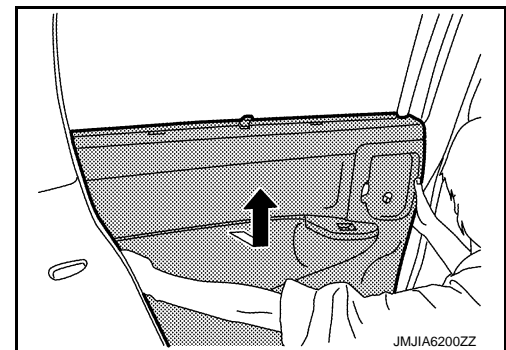

7. Remove the following parts after removing slide door finisher.
Remove power window switch.
 - Front window anti-pinch: Refer to [PWC-69, "Removal and Installation"](#).
 - Driver side window anti-pinch: Refer to [PWC-123, "Removal and Installation"](#).
8. Remove shade hook, if shade hook must be replaced.

SLIDE DOOR FINISHER

< REMOVAL AND INSTALLATION >

- Remove hook pin using a remover tool (A).

CAUTION:

Apply protective tape (B) on the part to protect it from damage.

- Pull toward vehicle lower, disengage shade hook fixing pawl, and then remove.

 : Pawl

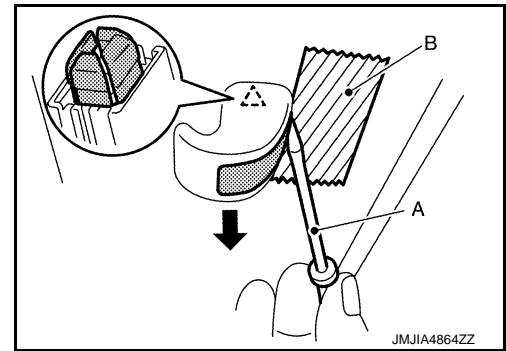

INSTALLATION

Note the following item, and install in the reverse order of removal.

CAUTION:

When installing, check in advance that clips are accurately aligned with the holes on body panel side, and then install by pressing in.

SECOND ROLL SUNSHADE

SECOND ROLL SUNSHADE : Disassembly

INFOID:000000009650278

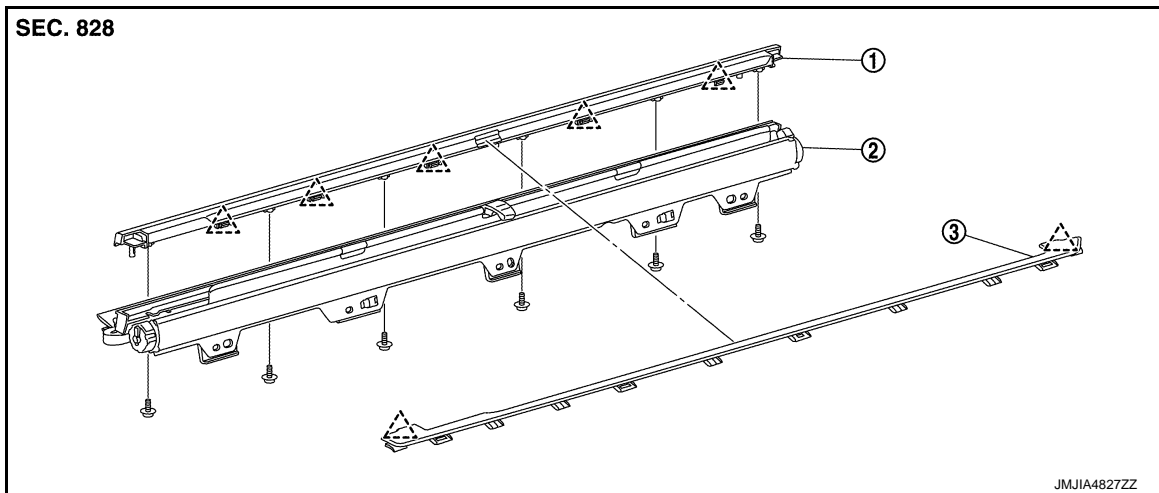

- Slide door sunshade escutcheon B
- Roll sunshade assembly
- Slide door sunshade escutcheon A

 : Pawl

SECOND ROLL SUNSHADE : Disassembly and Assembly

INFOID:000000009650279

CAUTION:

When removing, always use a remover tool that is made of plastic to prevent damage to the parts.

DISASSEMBLY

- Remove roll sunshade assembly fixing screws (A).

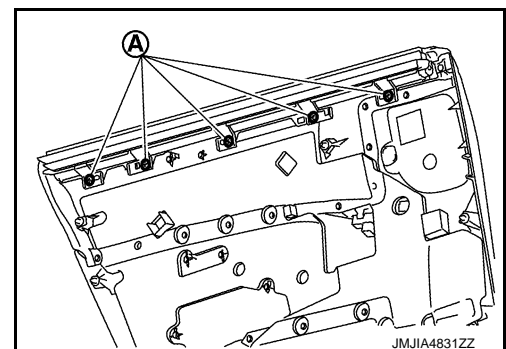

SLIDE DOOR FINISHER

< REMOVAL AND INSTALLATION >

2. Using a removal tool (A), disengage fixing pawls of slide door sunshade escutcheon A side, and then remove slide door sunshade escutcheon B and roll sunshade assembly as a set.

 : Pawl

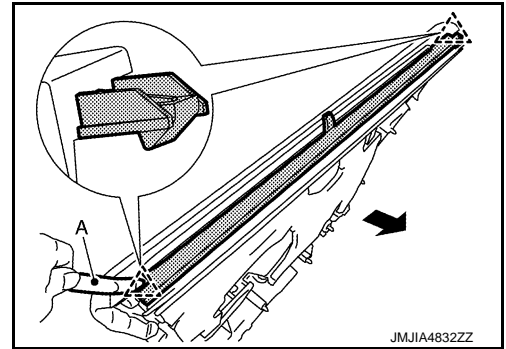

3. Remove slide door sunshade escutcheon B.

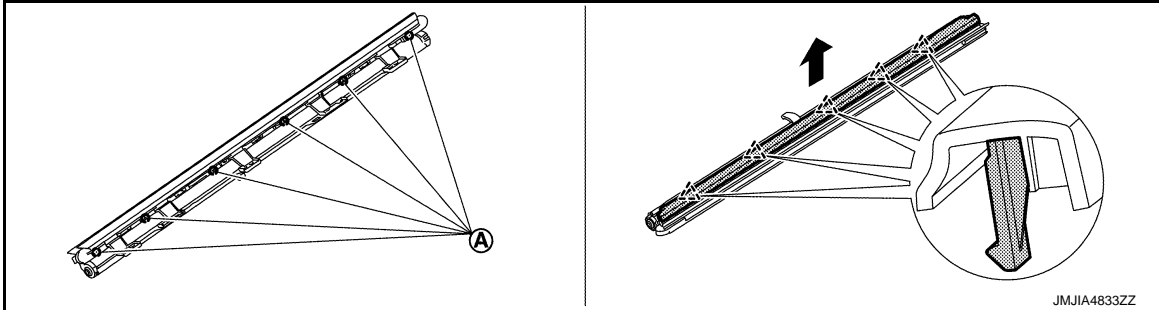

 : Pawl

- a. Remove slide door sunshade escutcheon B fixing screws (A).
 - b. Disengage slide door sunshade escutcheon B fixing pawls, and then remove slide door sunshade escutcheon B.
4. Remove slide door sunshade escutcheon A.
Disengage slide door sunshade escutcheon A fixing pawls, and then remove slide door sunshade escutcheon A.

 : Pawl

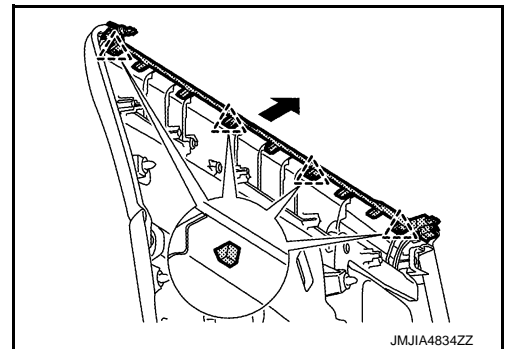

ASSEMBLY

Assembly in the reverse order of disassembly.

A
B
C
D
E
F
G
H
I
INT
K
L
M
N
O
P

BODY SIDE TRIM

< REMOVAL AND INSTALLATION >

BODY SIDE TRIM

Exploded View

INFOID:000000009650280

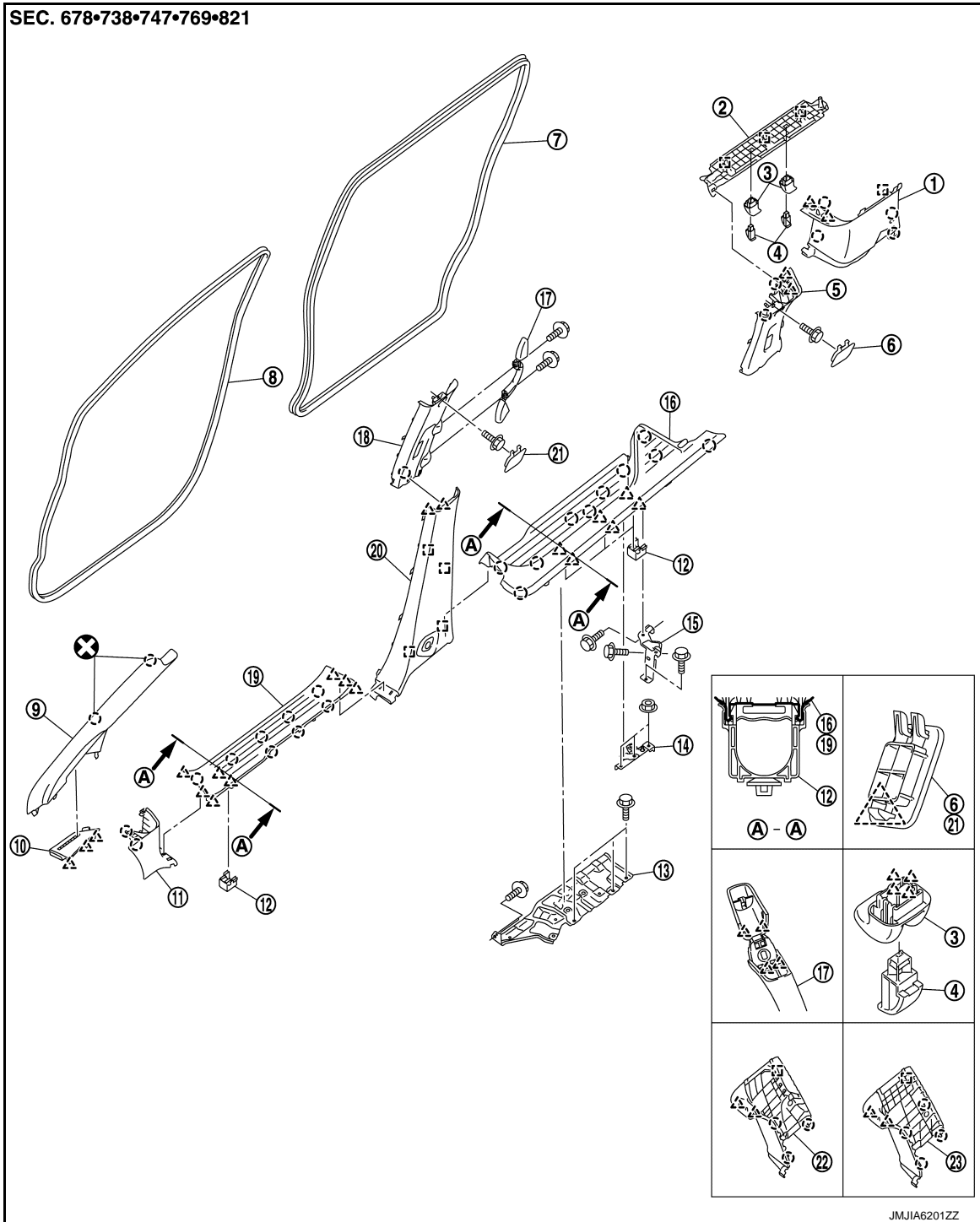

JMJIA6201ZZ

- | | | |
|--------------------------------|---------------------------------|-------------------------------------|
| 1. Back pillar garnish RH | 2. Roof side garnish | 3. Shade hook |
| 4. Hook pin | 5. Rear pillar garnish | 6. Rear pillar garnish cap |
| 7. Rear body side welt | 8. Front body side welt | 9. Front pillar garnish |
| 10. Front pillar lower garnish | 11. Dash side finisher | 12. Harness clip |
| 13. Rear floor step assembly | 14. Slide door striker | 15. Step bracket |
| 16. Rear kicking plate | 17. Assist grip | 18. Center pillar upper garnish |
| 19. Front kicking plate | 20. Center pillar lower garnish | 21. Center pillar upper garnish cap |

BODY SIDE TRIM

< REMOVAL AND INSTALLATION >

22. Back pillar garnish (with auto back door) 23. Back pillar garnish

- : Clip
△ : Pawl
□ : Metal clip
⊗ : Always replace after every disassembly.

FRONT PILLAR GARNISH

FRONT PILLAR GARNISH : Removal and Installation

INFOID:000000009650281

CAUTION:

- When removing, always use a remover tool that is made of plastic to prevent damage to the parts.
- Never damage the body.
- Fabric upholstered parts are easily damaged. Be careful while performing work and storing parts.
- Be careful not to pull out clips forcibly. Otherwise, vehicle body may be deformed.

REMOVAL

1. Remove front body side welt. Refer to [INT-23, "BODY SIDE WELT : Removal and Installation"](#).
2. Remove front pillar garnish.
 - a. Disengage front pillar garnish fixing anchor clips using a remover tool (A).

- : Anchor clip

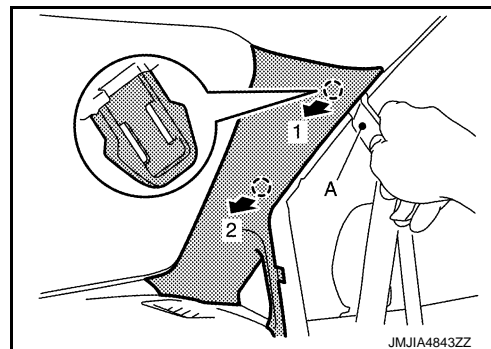

- b. Cut anchor clip (A) portion using nippers (B).

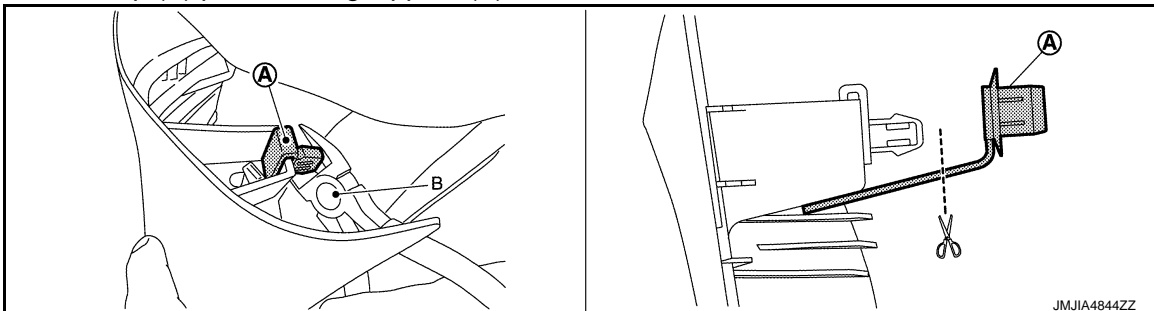

- c. Remove front pillar garnish while lifting it upward.

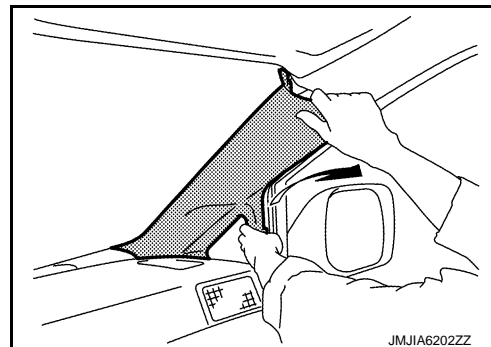

- d. Remove clips remaining on body side using a remover tool.

BODY SIDE TRIM

< REMOVAL AND INSTALLATION >

INSTALLATION

Note the following items, and install in the reverse order of removal.

CAUTION:

- When installing, check in advance that clips are accurately aligned with the holes on body panel side, and then install by pressing in.
- Never reuse front pillar garnish fixing anchor clip. Always replace it with a new one when it is removed.

FRONT PILLAR LOWER GARNISH

FRONT PILLAR LOWER GARNISH : Removal and Installation

INFOID:000000009650282

CAUTION:

Never damage the body.

REMOVAL

1. Lift up front pillar lower garnish toward vehicle upper. Disengage front pillar lower garnish fixing pawls, and then remove front pillar lower garnish.

 : Pawl

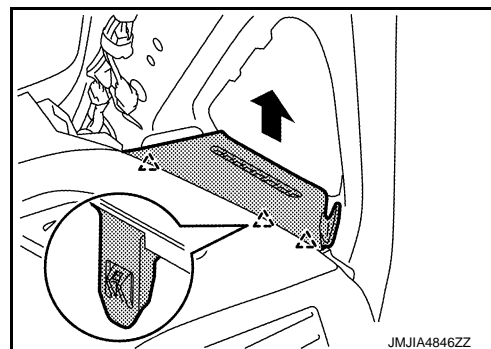

INSTALLATION

Install in the reverse order of removal.

KICKING PLATE

KICKING PLATE : Removal and Installation

INFOID:000000009650283

CAUTION:

- When removing, always use a remover tool that is made of plastic to prevent damage to the parts.
- Never damage the body.
- Be careful not to remove harness clip without disengaging pawl of harness clip. Harness clip may break if removed forcibly.

REMOVAL

FRONT KICKING PLATE

Disengage front kicking plate fixing clips and pawls using a remover tool, and then remove front kicking plate.

 : Clip

 : Pawl

NOTE:

Removing in the following order may allow less clips to remain on the vehicle body side.

1. Vehicle rear clip
2. Vehicle front clip
3. Vehicle front pawl
4. Vehicle rear pawl

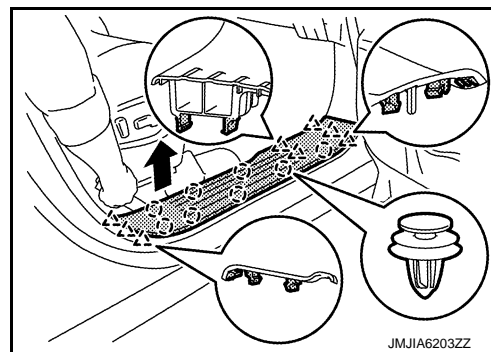

REAR KICKING PLATE

BODY SIDE TRIM

< REMOVAL AND INSTALLATION >

1. Disengage rear kicking plate fixing clips and pawls using a remover tool (A).

- : Clip
△ : Pawl

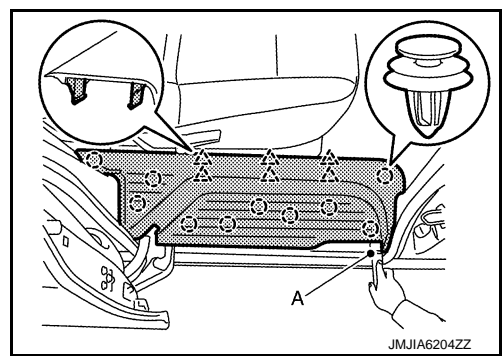

2. Hold the lower edge of rear kicking plate. Remove rear kicking plate while rotating it upward avoiding the portion overlapped with second seat.

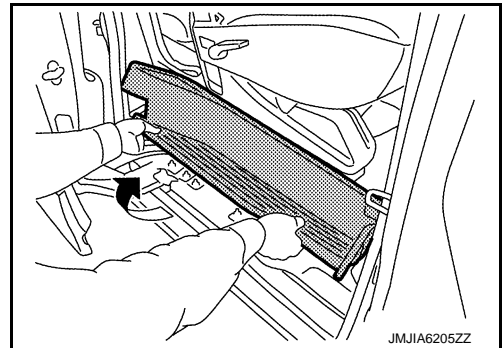

INSTALLATION

Note the following item, and install in the reverse order of removal.

CAUTION:

When installing, check in advance that clips are accurately aligned with the holes on body panel side, and then install by pressing in.

BODY SIDE WELT

BODY SIDE WELT : Removal and Installation

INFOID:000000009650284

INT

CAUTION:

- Never excessively pull body side welt.
- Never damage the body.

REMOVAL

FRONT BODY SIDE WELT

1. Remove front kicking plate. Refer to [INT-22, "KICKING PLATE : Removal and Installation"](#).
2. Remove front body side welt.

REAR BODY SIDE WELT

1. Remove rear kicking plate. Refer to [INT-22, "KICKING PLATE : Removal and Installation"](#).
2. Remove rear body side welt.

INSTALLATION

FRONT BODY SIDE WELT

Align body side welt identification color and vehicle position mark, and then install.

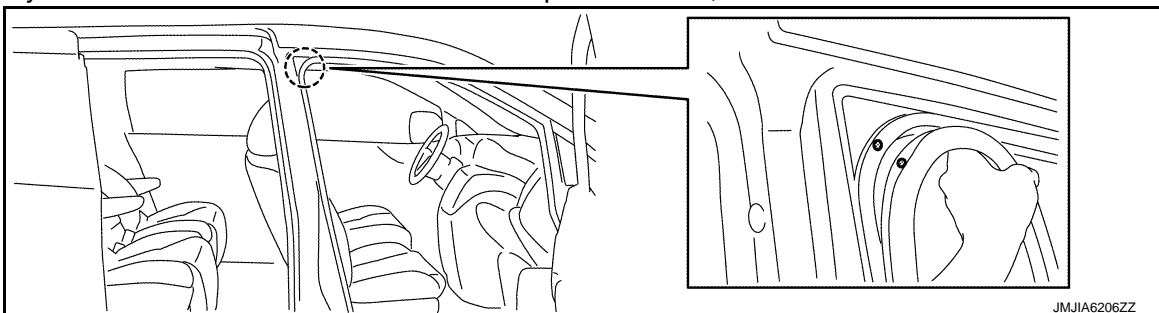

A
B
C
D
E
F
G
H
I
K
L
M
N
O
P

BODY SIDE TRIM

< REMOVAL AND INSTALLATION >

REAR BODY SIDE WELT

Install upper portion and both side surfaces in numerical order as shown in the figure.

← : Vehicle front

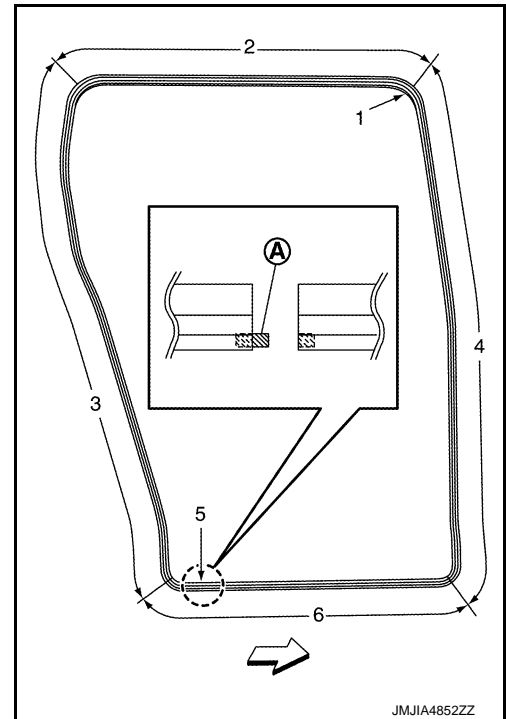

1. Align body side welt identification color and vehicle position mark.

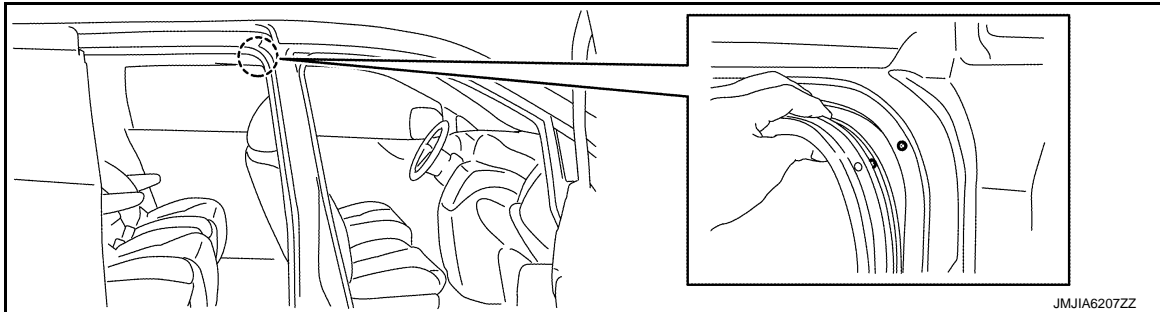

2. Install vehicle upper.
3. Install vehicle rear.
4. Install vehicle front.
5. Engage both ends using spacer (A), and then install lower portion.
6. Install vehicle lower.

DASH SIDE FINISHER

DASH SIDE FINISHER : Removal and Installation

INFOID:000000009650285

CAUTION:

Never damage the body.

REMOVAL

1. Remove front body side welt. Refer to [INT-23, "BODY SIDE WELT : Removal and Installation"](#).
2. Remove dash side finisher.

BODY SIDE TRIM

< REMOVAL AND INSTALLATION >

Pull dash side finisher toward vehicle inside, disengage fixing clips, and then remove dash side finisher.

 : Clip

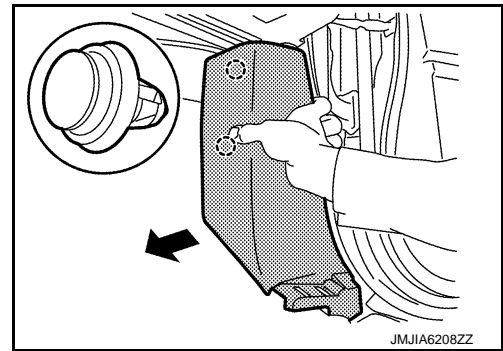

INSTALLATION

Note the following item, and install in the reverse order of removal.

CAUTION:

When installing, check in advance that clips are accurately aligned with the holes on body panel side, and then install by pressing in.

CENTER PILLAR LOWER GARNISH

CENTER PILLAR LOWER GARNISH : Removal and Installation

INFOID:000000009650286

CAUTION:

- When removing, always use a remover tool that is made of plastic to prevent damage to the parts.
- Never damage the body.

REMOVAL

1. Fully open front door and slide door.
2. Slide front seat to the fully forward position. Tilt seatback forward.
3. Remove front kicking plate and rear kicking plate. Refer to [INT-22. "KICKING PLATE : Removal and Installation"](#).
4. Remove front body side welt and rear body side welt. Refer to [INT-23. "BODY SIDE WELT : Removal and Installation"](#).
5. Remove front seat belt outer anchor. Refer to [SB-5. "SEAT BELT RETRACTOR : Removal and Installation"](#).
6. Remove center pillar lower garnish.
 - a. Disengage center pillar lower garnish fixing pawls and metal clips using a remover tool (A).

 : Pawl

 : Metal clip

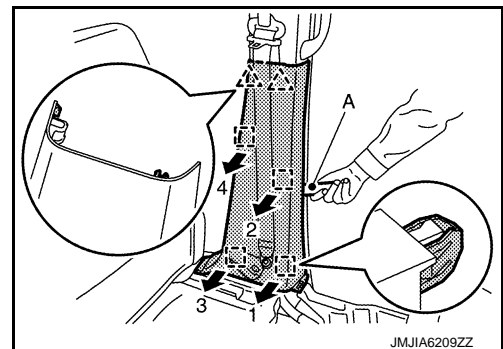

- b. Disconnect harness connector. (with power sliding)
- c. Remove center pillar lower garnish.

INSTALLATION

Note the following item, and install in the reverse order of removal.

CAUTION:

When installing, check in advance that metal clips are accurately aligned with the holes on body panel side, and then install by pressing in.

CENTER PILLAR UPPER GARNISH

BODY SIDE TRIM

< REMOVAL AND INSTALLATION >

CENTER PILLAR UPPER GARNISH : Removal and Installation

INFOID:00000009650287

CAUTION:

- When removing, always use a remover tool that is made of plastic to prevent damage to the parts.
- Never damage the body.
- Fabric upholstered parts are easily damaged. Be careful while performing work and storing parts.

REMOVAL

1. Remove center pillar lower garnish. Refer to [INT-25, "CENTER PILLAR LOWER GARNISH : Removal and Installation"](#).

2. Remove assist grip.

- a. Disengage assist grip cap fixing pawls using a remover tool (A).

CAUTION:

Apply protective tape (B) on the part to protect it from damage.

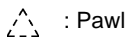

: Pawl

- b. Remove assist grip fixing bolts, and then remove assist grip.

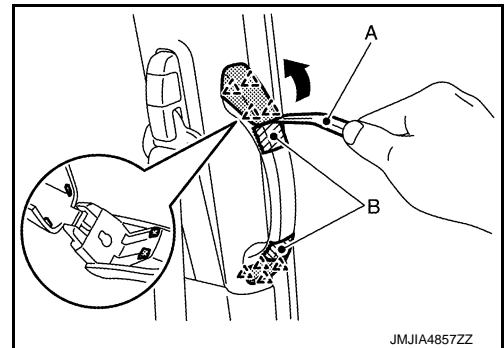

3. Remove front seat belt shoulder anchor. Refer to [SB-5, "SEAT BELT RETRACTOR : Removal and Installation"](#).

4. Remove center pillar upper garnish cap.
Disengage center pillar upper garnish cap fixing pawl using a remover tool (A).

CAUTION:

Apply protective tape (B) on the part to protect it from damage.

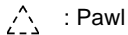

: Pawl

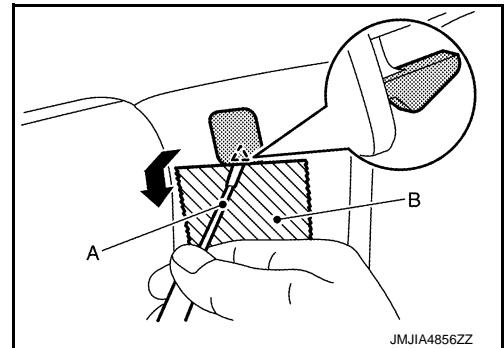

5. Remove center pillar upper garnish fixing bolt.

6. Remove center pillar upper garnish.
Disengage center pillar upper garnish fixing clip using a remover tool (A), and then remove center pillar upper garnish.

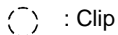

: Clip

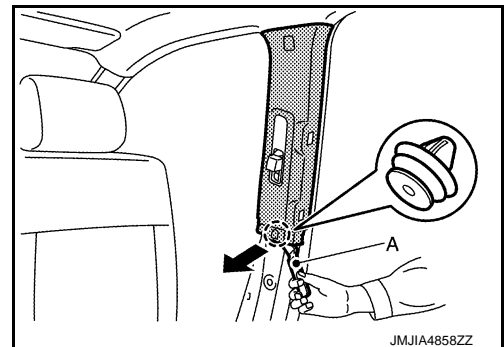

INSTALLATION

Note the following item, and install in the reverse order of removal.

CAUTION:

When installing, check in advance that clips are accurately aligned with the holes on body panel side, and then install by pressing in.

REAR PILLAR GARNISH

BODY SIDE TRIM

< REMOVAL AND INSTALLATION >

REAR PILLAR GARNISH : Removal and Installation

INFOID:000000009650288

CAUTION:

- When removing, always use a remover tool that is made of plastic to prevent damage to the parts.
- Never damage the body.
- When removing, be careful not to damage or drop fixing clips on the side window side.

REMOVAL

1. Remove luggage side lower finisher. Refer to [INT-43, "LUGGAGE SIDE LOWER FINISHER : Removal and Installation"](#).
2. Remove second seat belt shoulder anchor. Refer to [SB-11, "SEAT BELT RETRACTOR : Removal and Installation"](#).
3. Remove rear pillar garnish cap.
disengage rear pillar garnish cap fixing pawl using a remover tool (A), and then remove rear pillar garnish cap.

CAUTION:

Apply protective tape (B) on the part to protect it from damage.

 : Pawl

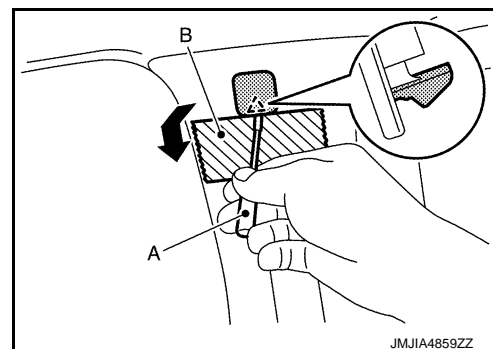

4. Remove rear pillar garnish fixing bolt.
5. Remove rear pillar garnish.
Disengage rear pillar garnish fixing clips and pawls using a remover tool (A), and then remove rear pillar garnish.

 : Clip

 : Pawl

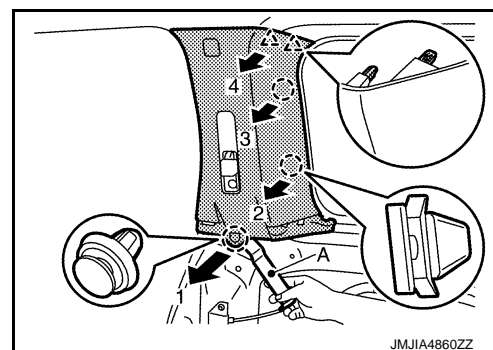

INSTALLATION

Note the following items, and install in the reverse order of removal.

CAUTION:

- When installing, check in advance that clips are accurately aligned with the holes on body panel side, and then install by pressing in.
- When installing, be careful not to damage or drop clips on the side window side.

BACK PILLAR GARNISH

BACK PILLAR GARNISH : Removal and Installation

INFOID:000000009650289

CAUTION:

- When removing, always use a remover tool that is made of plastic to prevent damage to the parts.
- Never damage the body.
- Be careful not to bend headlining.
- Be careful not to damage or drop fixing clips on the side window side.

REMOVAL

1. Remove luggage side lower finisher. Refer to [INT-43, "LUGGAGE SIDE LOWER FINISHER : Removal and Installation"](#).

BODY SIDE TRIM

< REMOVAL AND INSTALLATION >

2. Remove back door support rod. (with auto back door) Refer to [DLK-477. "BACK DOOR SUPPORT ROD : Removal and Installation"](#).
3. Remove third seat belt shoulder anchor. Refer to [SB-16. "SEAT BELT RETRACTOR : Removal and Installation"](#).
4. Remove back pillar garnish.
 - a. Disengage back pillar garnish fixing clips using a remover tool (A).

 : Clip

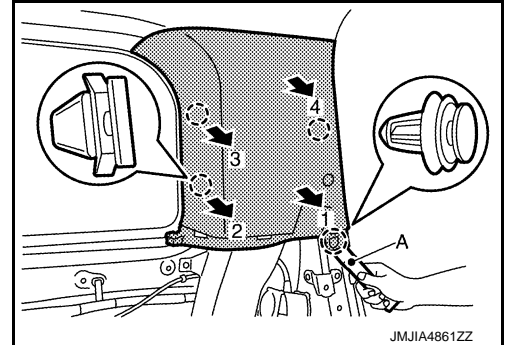

- b. Disengage back pillar garnish fixing pawls using a remover tool (A).
CAUTION:
Apply protective tape (B) on the part to protect it from damage.

 : Pawl

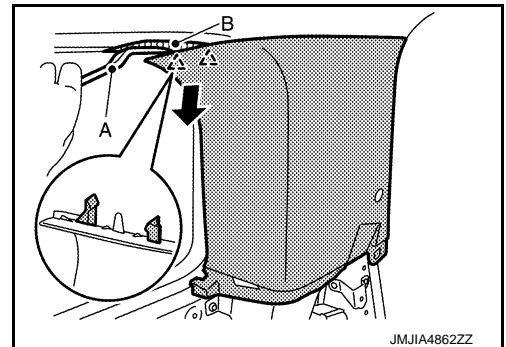

- c. Disengage back pillar garnish fixing metal clip using a remover tool (A), and then remove back pillar garnish.
CAUTION:
Be careful not to deform headlining when removing because headlining is inserted into groove of back pillar garnish.

 : Metal clip

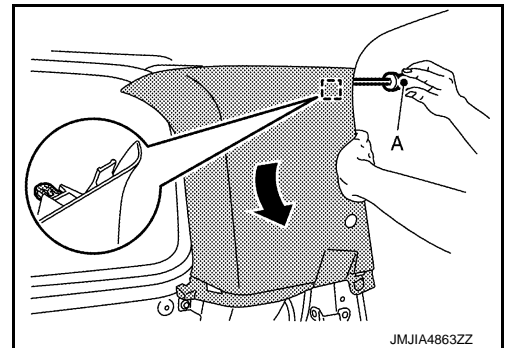

INSTALLATION

Note the following items, and install in the reverse order of removal.

CAUTION:

- When installing, check in advance that clips and metal clip are accurately aligned with the holes on body panel side, and then install by pressing in.
- When installing, be careful not to damage or drop clips on the side window side.

ROOF SIDE GARNISH

ROOF SIDE GARNISH : Removal and Installation

INFOID:000000009650290

CAUTION:

- When removing, always use a remover tool that is made of plastic to prevent damage to the parts.
- Never damage the body.
- Be careful not to damage roof side garnish when removing because roof side garnish is damaged easily.
- Be careful not to bend headlining.

REMOVAL

1. Remove rear pillar garnish. Refer to [INT-27. "REAR PILLAR GARNISH : Removal and Installation"](#).

BODY SIDE TRIM

< REMOVAL AND INSTALLATION >

2. Remove back pillar garnish. Refer to [INT-27. "BACK PILLAR GARNISH : Removal and Installation"](#).
3. Remove shade hook. (with sunshade)
- a. Remove hook pin using a remover tool (A).

CAUTION:

Apply protective tape (B) on the part to protect it from damage.

- b. Pull toward vehicle lower, disengage shade hook fixing pawl, and then remove.

 : Pawl

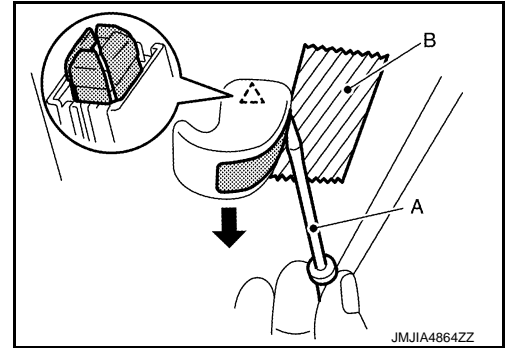

4. Remove roof side garnish.
- a. Disengage roof side garnish fixing metal clips using a remover tool (A)

 : Metal clip

- b. Lower roof side garnish from the vehicle body outside to remove.

CAUTION:

Be careful not to deform headlining when removing, because headlining is inserted into groove of roof side garnish.

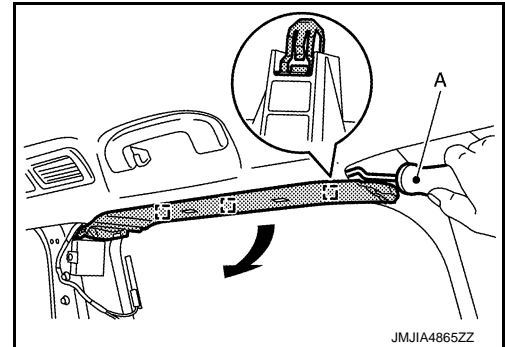

INSTALLATION

Note the following item, and install in the reverse order of removal.

CAUTION:

When installing, check in advance that metal clips are accurately aligned with the holes on body panel side, and then install by pressing in.

A

B

C

D

E

F

G

H

I

INT

K

L

M

N

O

P

FLOOR TRIM

< REMOVAL AND INSTALLATION >

FLOOR TRIM

Exploded View

INFOID:000000009650291

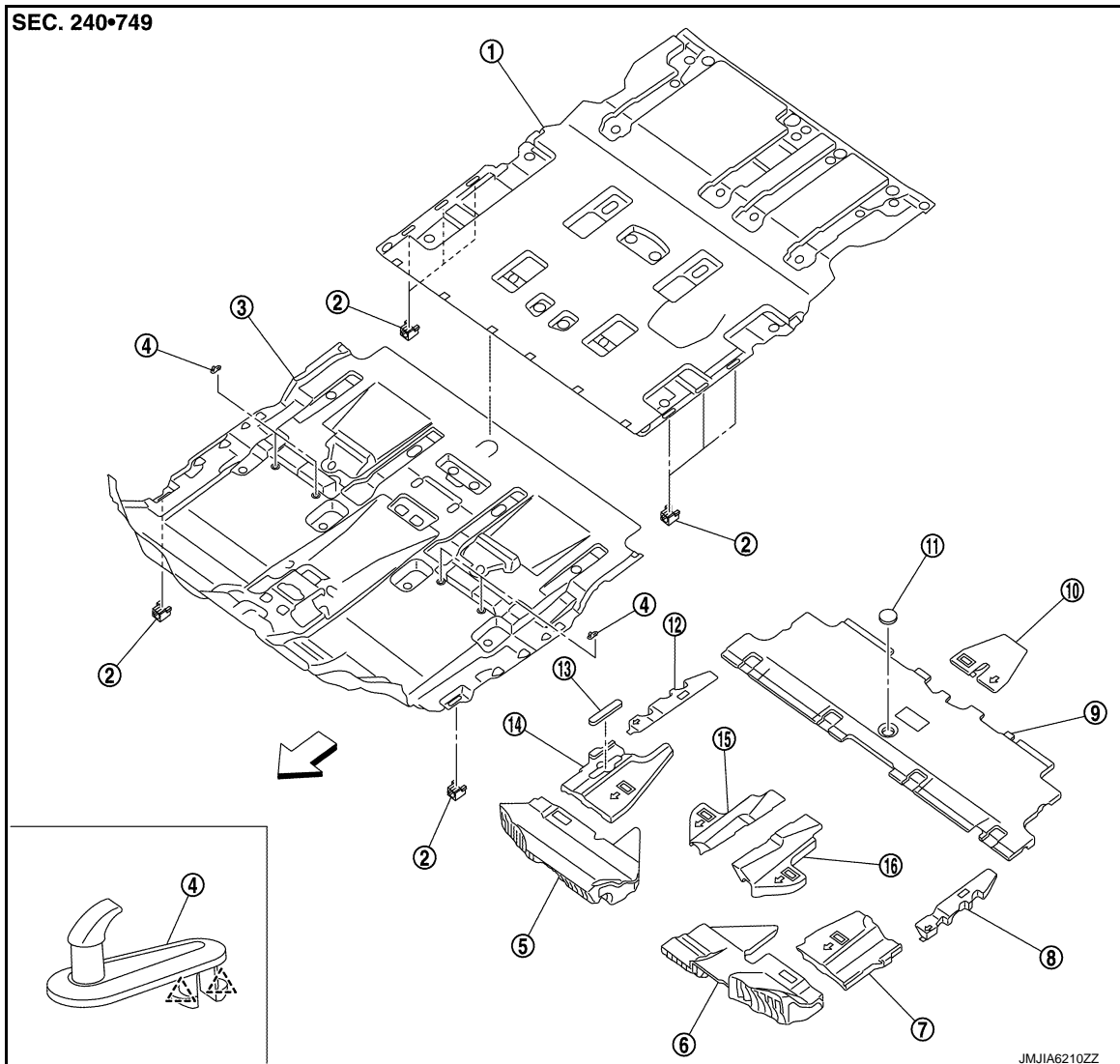

- | | | |
|--------------------------|---------------------------------|----------------------------------|
| 1. Rear floor carpet | 2. Harness clip | 3. Front carpet |
| 4. Carpet hook | 5. Front floor pad RH | 6. Front floor pad LH |
| 7. Front floor spacer RH | 8. Front floor center spacer LH | 9. Center floor insulator |
| 10. Rear floor spacer | 11. Center floor insulator A | 12. Front floor center spacer RH |
| 13. Floor spacer C | 14. Front floor spacer RH | 15. Floor side spacer RH |
| 16. Floor side spacer LH | | |

 : Pawl

 : Vehicle front

FRONT FLOOR CARPET

FRONT FLOOR CARPET : Removal and Installation

INFOID:000000009650292

CAUTION:

- When removing, always use a remover tool that is made of plastic to prevent damage to the parts.
- Never damage the body.

REMOVAL

FLOOR TRIM

< REMOVAL AND INSTALLATION >

1. Remove heater & cooling unit assembly. Refer to [HA-49, "HEATER & COOLING UNIT ASSEMBLY : Removal and Installation"](#).
2. Remove control cable from CVT shift selector assembly. Refer to [TM-156, "Removal and Installation"](#).
3. Remove diagnosis sensor unit. Refer to [SR-29, "Removal and Installation"](#).
4. Remove yaw rate/side/decel G sensor. Refer to [BRC-125, "Removal and Installation"](#).
5. Remove front seat assembly.
 - Manual seat: Refer to [SE-88, "Removal and Installation"](#).
 - Power seat: Refer to [SE-102, "Removal and Installation"](#).
6. Remove harness fixing clip (A) on the underside of driver seat assembly and passenger seat assembly.

← : Vehicle front

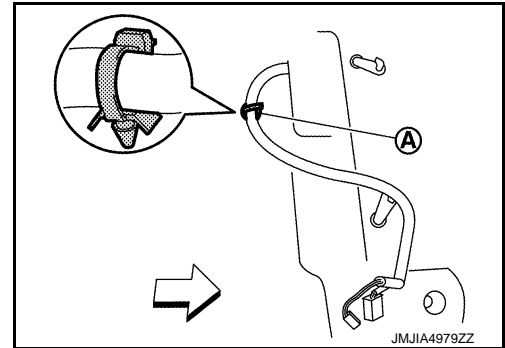

7. Remove center console assembly. Refer to [IP-28, "Removal and Installation"](#).
8. Remove center pillar lower garnish. Refer to [INT-25, "CENTER PILLAR LOWER GARNISH : Removal and Installation"](#).
9. Remove dash side finisher. Refer to [INT-24, "DASH SIDE FINISHER : Removal and Installation"](#).
10. Disengage magic fastener, and then remove front floor carpet.

NOTE:

Remove carpet hook.

1. Disengage carpet hook fixing pawls using a remover tool (A).
2. Remove carpet hook from front floor carpet.

△ : Pawl

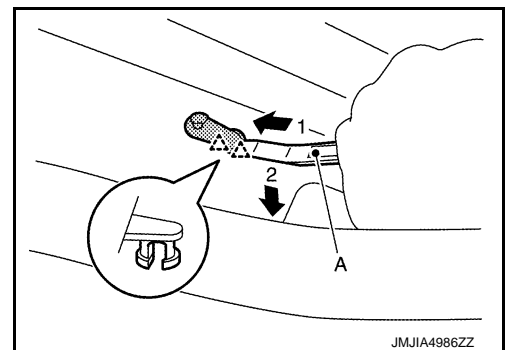

INSTALLATION

Note the following item, and install in the reverse order of removal.

CAUTION:

Replace diagnosis sensor unit fixing bolts with a new part after removal. Never reuse diagnosis sensor unit fixing bolts.

REAR FLOOR CARPET

REAR FLOOR CARPET : Removal and Installation

INFOID:000000009650293

CAUTION:

- When removing, always use a remover tool that is made of plastic to prevent damage to the parts.
- Never damage the body.

REMOVAL

1. Remove luggage side lower finisher. Refer to [INT-43, "LUGGAGE SIDE LOWER FINISHER : Removal and Installation"](#).
2. Remove second seat. Refer to [SE-114, "Removal and Installation"](#).
3. Remove rear console assembly. Refer to [IP-32, "Removal and Installation"](#).

FLOOR TRIM

< REMOVAL AND INSTALLATION >

4. Remove harness fixing clip (A). (with third seat hold switch)

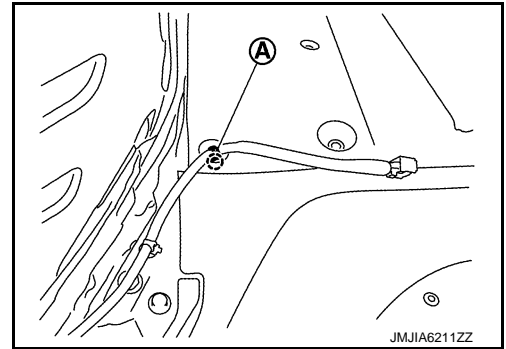

5. Disengage magic fastener, and then remove rear floor carpet.

INSTALLATION

Install in the reverse order of removal.

HEADLINING

< REMOVAL AND INSTALLATION >

HEADLINING

Exploded View

INFOID:000000009650294

NOMAL ROOF

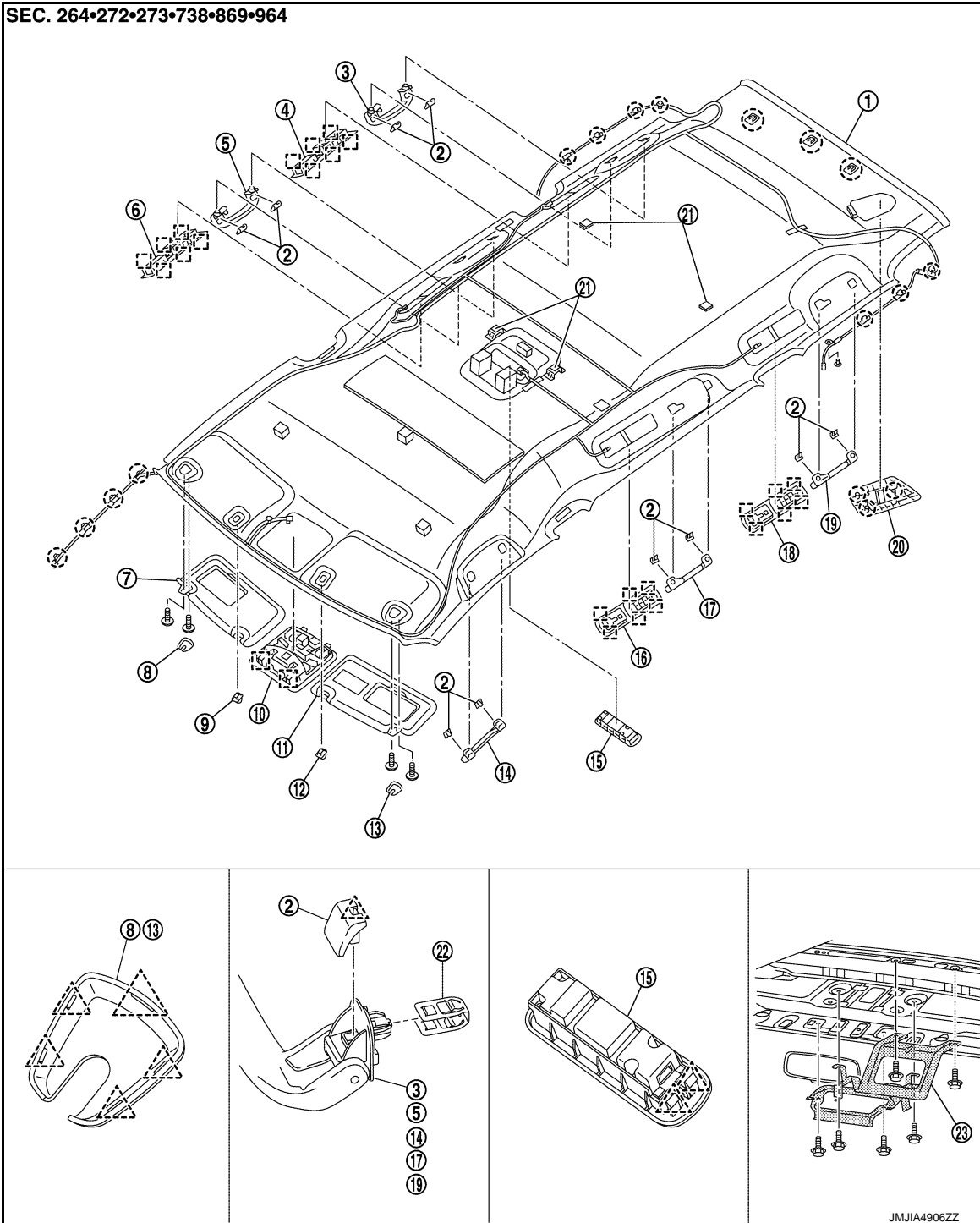

- | | | |
|---------------------------------|---------------------------|---------------------------------|
| 1. Headlining assembly | 2. Assist grip cap | 3. Third assist grip RH |
| 4. Rear ventilator grille B RH | 5. Second assist grip RH | 6. Rear ventilator grille A RH |
| 7. Sun visor assembly RH | 8. Sun visor cover RH | 9. Sun visor holder RH |
| 10. Map lamp assembly | 11. Sun visor assembly LH | 12. Sun visor holder LH |
| 13. Sun visor cover LH | 14. Front assist grip | 15. Rear A/C control |
| 16. Rear ventilator grille A LH | 17. Second assist grip LH | 18. Rear ventilator grille B LH |

JMJIA4906ZZ

A
B
C
D
E
F
G
H
I
INT
K
L
M
N
O
P

HEADLINING

< REMOVAL AND INSTALLATION >

- | | | |
|--------------------------|------------------------|------------------------|
| 19. Third assist grip LH | 20. Seat belt finisher | 21. Dual lock fastener |
| 22. Metal clip | 23. Map lamp bracket | |

○ : Clip

△ : Pawl

□ : Metal clip

SUNROOF

SEC. 251•264•272•273•738•869•964•970

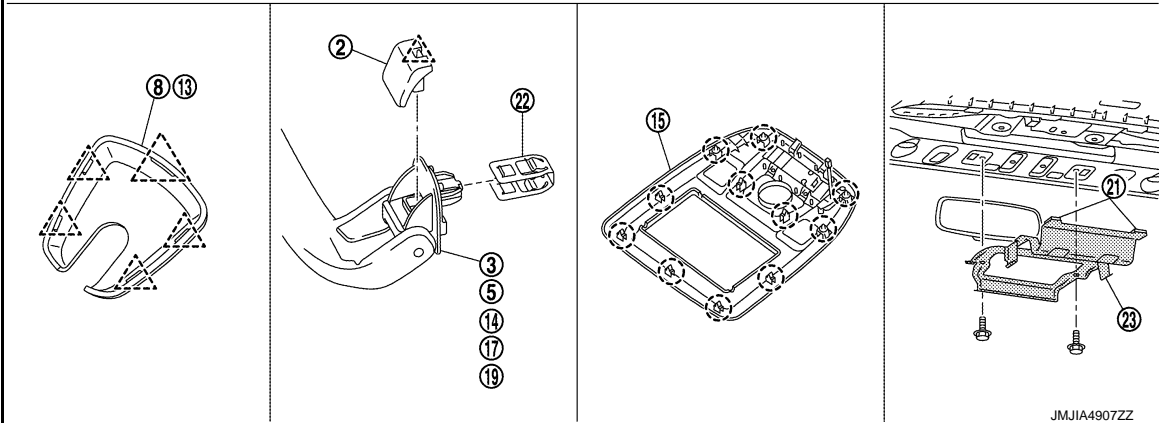
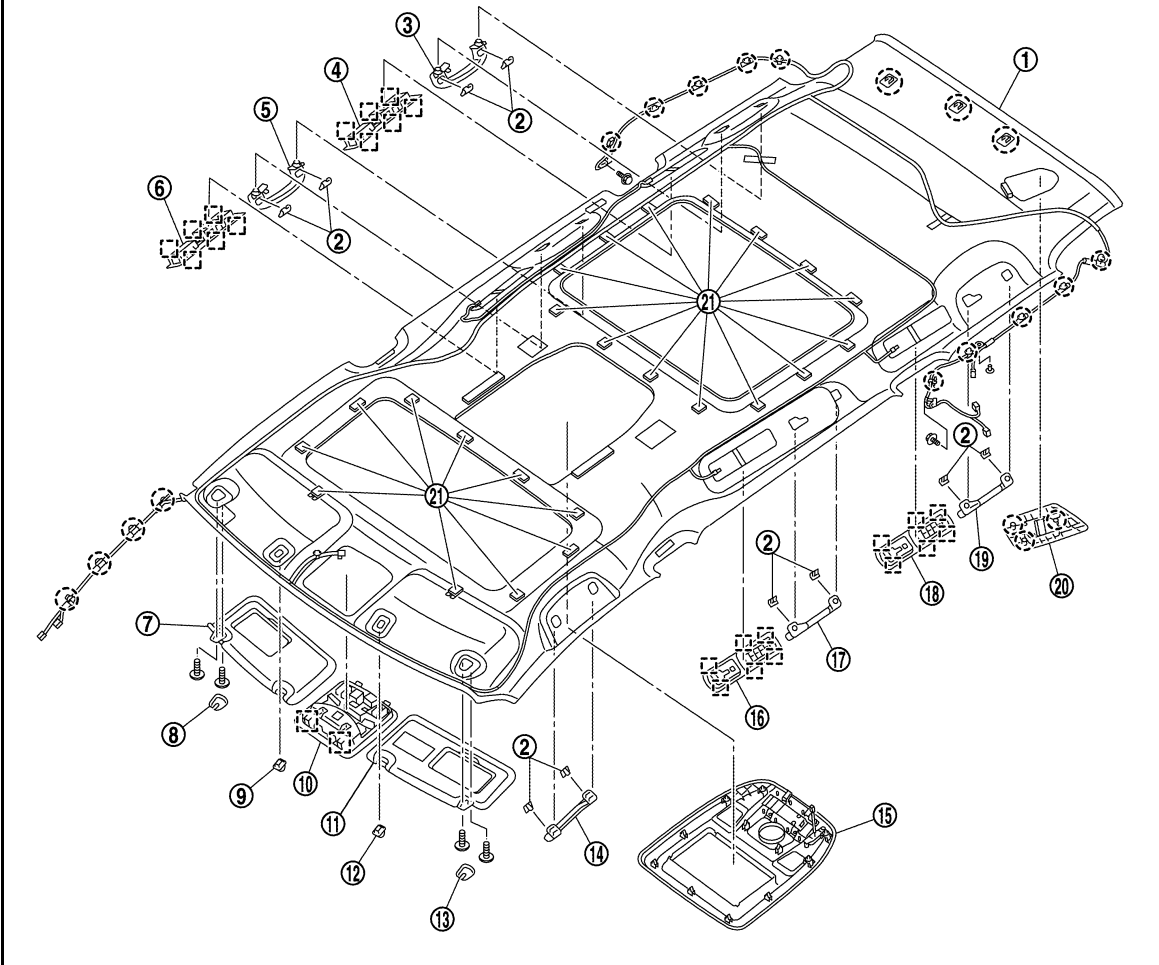

JMJIA4907ZZ

- | | | |
|--------------------------------|---------------------------|--------------------------------|
| 1. Headlining assembly | 2. Assist grip cap | 3. Third assist grip RH |
| 4. Rear ventilator grille B RH | 5. Second assist grip RH | 6. Rear ventilator grille A RH |
| 7. Sun visor assembly RH | 8. Sun visor cover RH | 9. Sun visor holder RH |
| 10. Map lamp assembly | 11. Sun visor assembly LH | 12. Sun visor holder LH |

HEADLINING

< REMOVAL AND INSTALLATION >

- | | | |
|---------------------------------|---------------------------|---------------------------------|
| 13. Sun visor cover LH | 14. Front assist grip | 15. Roof console |
| 16. Rear ventilator grille A LH | 17. Second assist grip LH | 18. Rear ventilator grille B LH |
| 19. Third assist grip LH | 20. Seat belt finisher | 21. Dual lock fastener |
| 22. Metal clip | 23. Map lamp bracket | |

○ : Clip

△ : Pawl

□ : Metal clip

Removal and Installation

INFOID:000000009650295

CAUTION:

- When removing, always use a remover tool that is made of plastic to prevent damage to the parts.
- Never damage the body.

REMOVAL

1. Remove front pillar garnish. Refer to [INT-21, "FRONT PILLAR GARNISH : Removal and Installation"](#).
2. Disconnect harness connector (A) from headlining and harness fixing clips.

○ : Clip

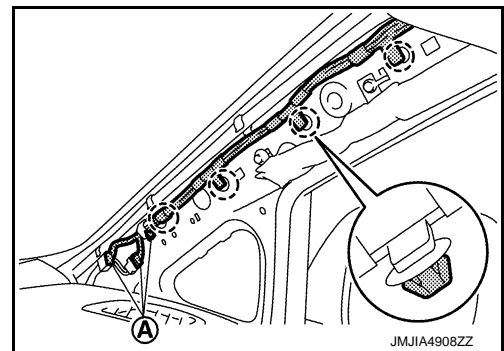

3. Remove map lamp assembly. Refer to [INL-67, "Removal and Installation"](#).

4. Disconnect harness connector (A), and then disengage harness fixing clip.

○ : Clip

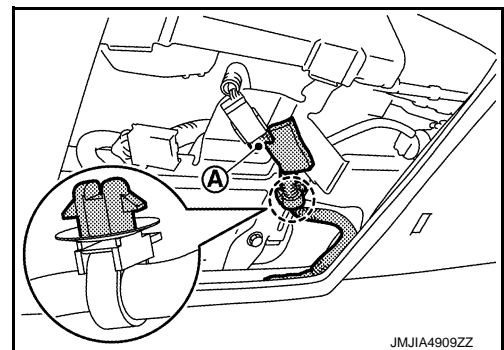

5. Remove sun visor assembly.

- a. Disengage sun visor cover fixing pawls using a remover tool (A), and then remove sun visor cover.

△ : Pawl

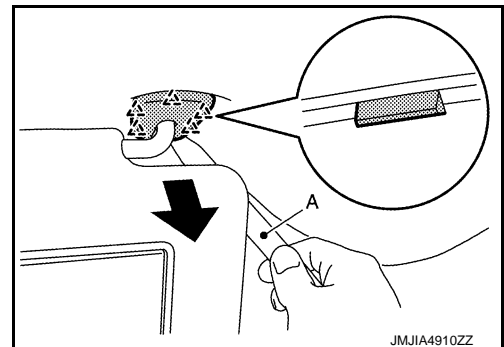

- b. Remove sun visor fixing screws.
- c. Disconnect harness connector, and then remove sun visor assembly.
6. Remove sun visor holder.

HEADLINING

< REMOVAL AND INSTALLATION >

Rotate 90°. Remove toward vehicle dower.

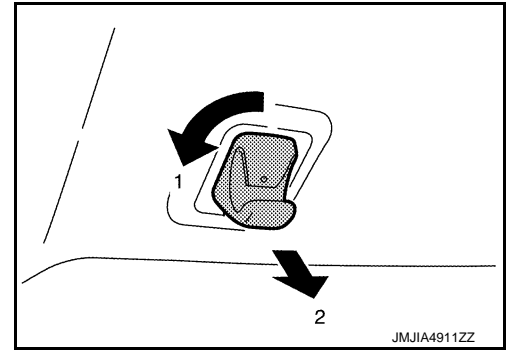

7. Remove all assist grips.
 - a. Disengage pawl of assist grip clip (1) using a remover tool (A). Slide assist grip clip forward and remove it.

 : Pawl

- b. Slide assist grip (2) forward and remove it.

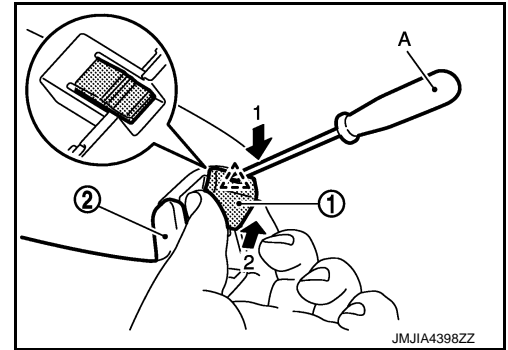

8. Remove roof console. (with rear display)
 - a. Disengage roof console fixing clips using a remover tool (A).

 : Clip

- b. Disconnect harness connector, and then remove roof console.

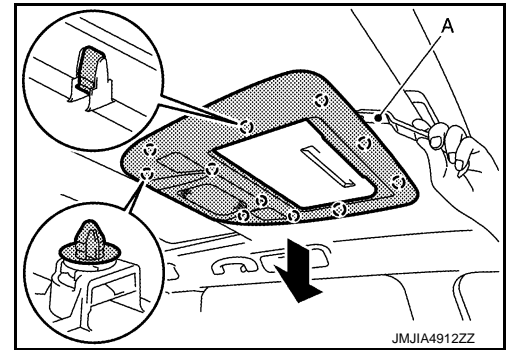

9. Remove center pillar upper garnish. Refer to [INT-26. "CENTER PILLAR UPPER GARNISH : Removal and Installation"](#).
10. Remove roof side garnish. Refer to [INT-28. "ROOF SIDE GARNISH : Removal and Installation"](#).
11. Disengage antenna feeder connector (A), (B), (C), and fixing bolt (D).

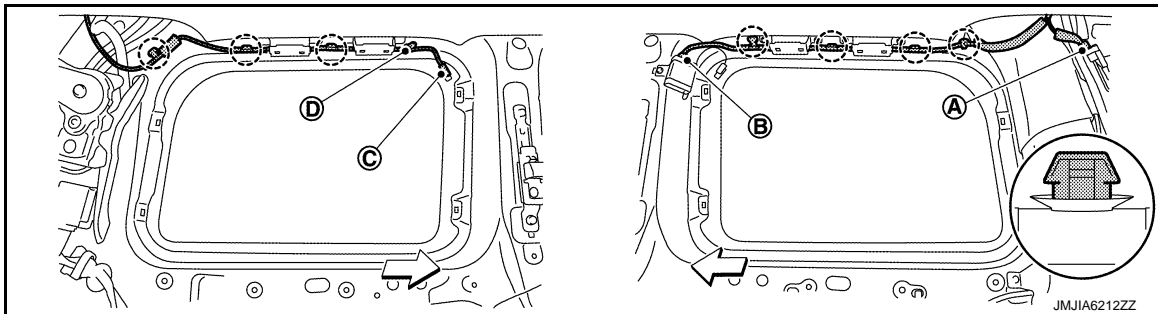

Left side

Right side

 : Pawl

 : Vehicle front

HEADLINING

< REMOVAL AND INSTALLATION >

12. Remove seat belt finisher.

Disengage seat belt finisher fixing clips using a remover tool (A), and then remove seat belt finisher.

 : Clip

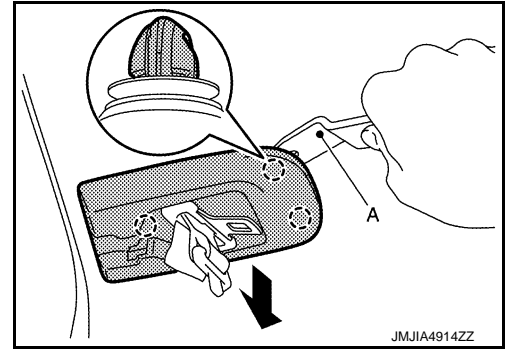

13. Disengage clips on the rear end of headlining.

14. Peel dual lock fastener (A).

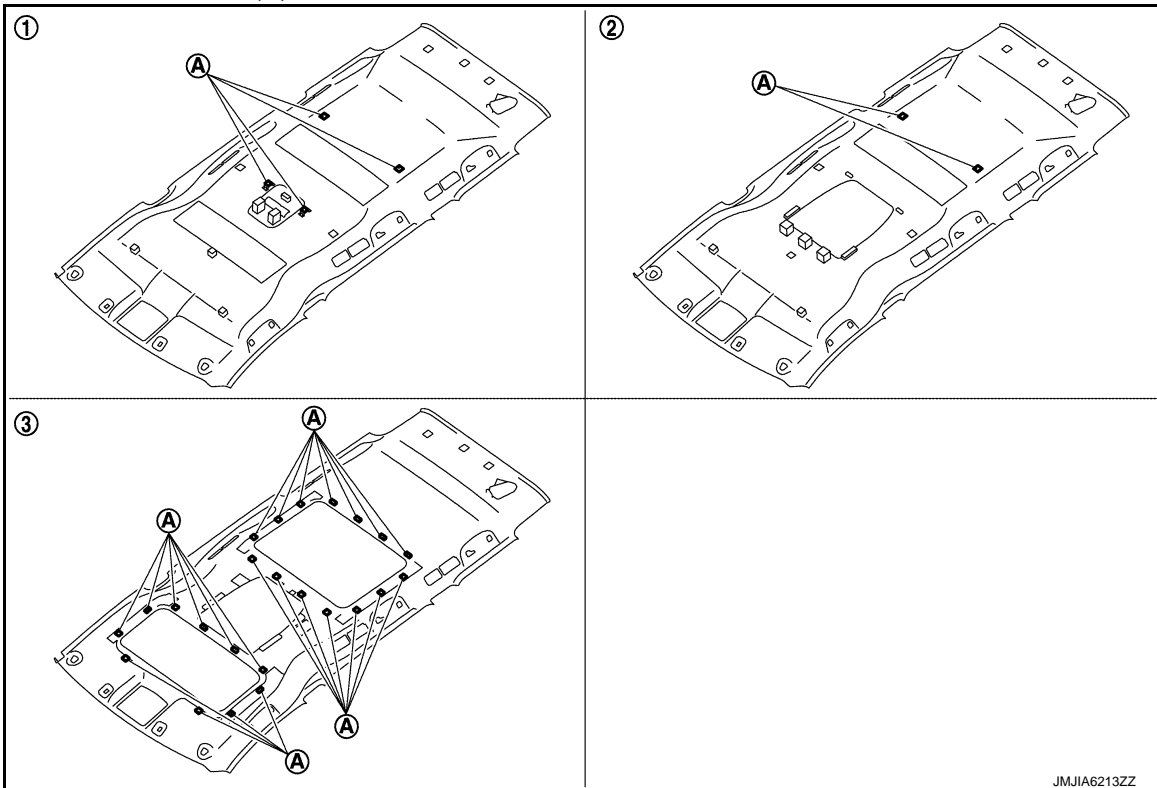

1. Normal roof

2. Normal roof with rear display

3. Sunroof with rear display

A. Dual lock fastener

15. Remove headlining assembly through the back door.

CAUTION:

- Two workers are required for removal in order to prevent damage.
- Apply protective tape to the portion where contact may occur during work.
- ever bend headlining when removing.

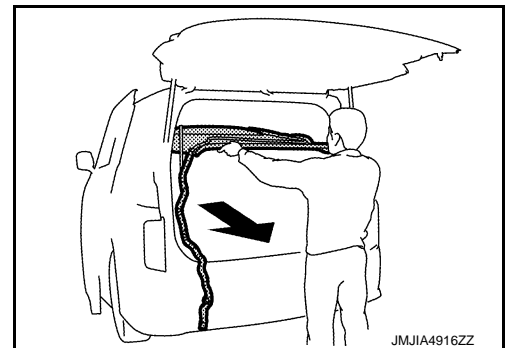

16. Remove the following parts after removing headlining assembly.

- Personal lamp assembly: Refer to [INL-77, "Removal and Installation"](#).
- Rear A/C control (without rear display)
Automatic air conditioning: Refer to [HAC-144, "Removal and Installation"](#).

A
B
C
D
E
F
G
H
I
INT
K
L
M
N
O
P

HEADLINING

< REMOVAL AND INSTALLATION >

Manual air conditioning: Refer to [HAC-239, "Removal and Installation"](#).

INSTALLATION

Note the following items, and install in the reverse order of removal.

CAUTION:

- When installing headlining, start by installing both sun visor holders and headlining clips in order to keep the headlining in position.
- Never bend headlining when installing.
- When installing assist grip, install metal clip (1) to assist grip clip (2), and then install to the vehicle body.

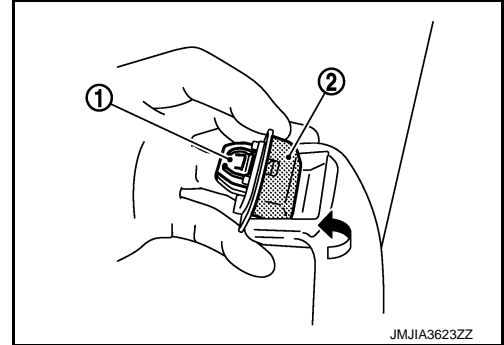

NOTE:

When removing assist grip clip, metal clip remains on body side.

LUGGAGE FLOOR TRIM

< REMOVAL AND INSTALLATION >

LUGGAGE FLOOR TRIM

Exploded View

INFOID:000000009650296

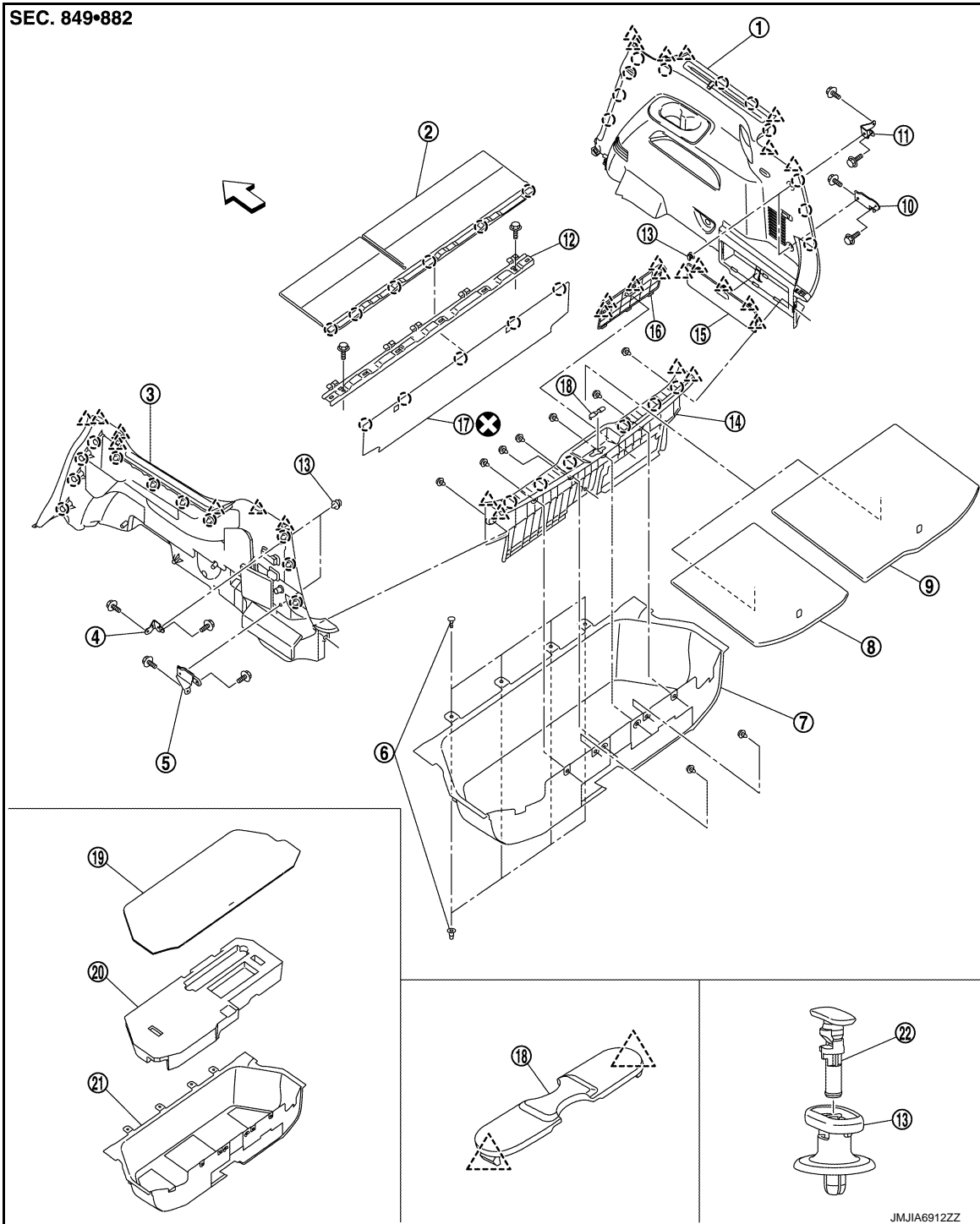

A
B
C
D
E
F
G
H
I
INT
K
L
M
N
O
P

- | | | |
|-----------------------------------|----------------------------------|-----------------------------------|
| 1. Luggage side lower finisher RH | 2. Luggage floor front board | 3. Luggage side lower finisher LH |
| 4. Luggage trim rear bracket LH | 5. Luggage side lower bracket LH | 6. Grommet |
| 7. Luggage floor box | 8. Luggage floor rear board LH | 9. Luggage floor rear board RH |
| 10. Luggage side lower bracket RH | 11. Luggage trim rear bracket RH | 12. Luggage floor front bracket |
| 13. Net hook | 14. Tailgate kicking plate | 15. Luggage side lid |
| 16. Luggage floor box cover | 17. Cable cover | 18. Tailgate kicking plate mask |

LUGGAGE FLOOR TRIM

< REMOVAL AND INSTALLATION >

- | | | |
|---|--|--|
| 19. Luggage floor center board
(with BOSE audio) | 20. Luggage floor front box
(with BOSE audio) | 21. Luggage floor box
(with BOSE audio) |
|---|--|--|

22. Net hook pin

 : Clip

 : Pawl

 : Vehicle front

 : Always replace after every disassembly.

LUGGAGE FLOOR REAR BOARD

LUGGAGE FLOOR REAR BOARD : Removal and Installation

INFOID:000000009650297

REMOVAL

1. Disengage button (A).
2. Remove strap, and then remove luggage floor rear board.

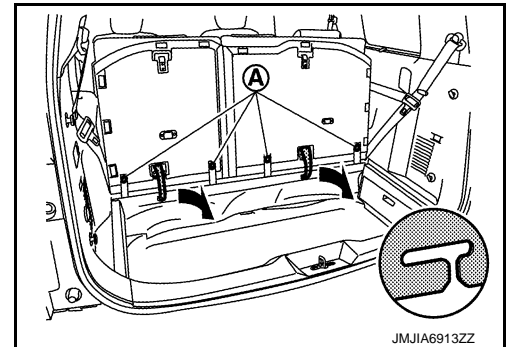

INSTALLATION

Install in the reverse order of removal.

TAILGATE KICKING PLATE

TAILGATE KICKING PLATE : Removal and Installation

INFOID:000000009650298

CAUTION:

- When removing, always use a remover tool that is made of plastic to prevent damage to the parts.
- Never damage the body.

REMOVAL

1. Remove back door weather strip. Refer to [DLK-457. "BACK DOOR WEATHER-STRIP : Removal and Installation"](#).
2. Remove luggage floor rear board. Refer to [INT-40. "LUGGAGE FLOOR REAR BOARD : Removal and Installation"](#).
3. Remove luggage floor center board and luggage floor front box. (with BOSE audio)
4. Disengage tailgate kicking plate mask fixing pawls using a remover tool (A), and then remove tailgate kicking plate mask.

CAUTION:

Apply protective tape (B) on the part to protect it from damage.

 : Pawl

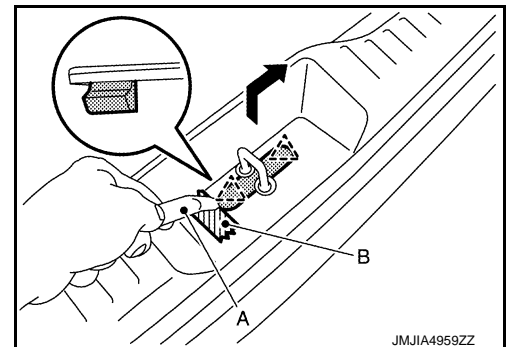

5. Remove tailgate kicking plate.

LUGGAGE FLOOR TRIM

< REMOVAL AND INSTALLATION >

- a. Disengage tailgate kicking plate fixing clips (A).

↶ : Vehicle front

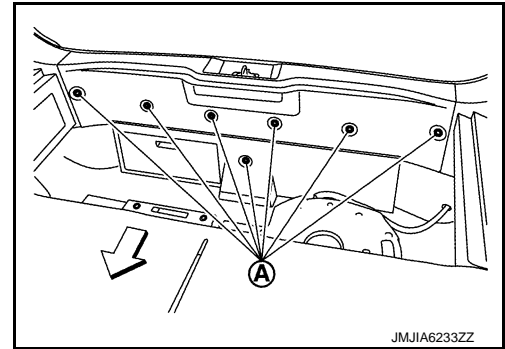

- b. Disengage tailgate kicking plate fixing clips and pawls using a remover tool (A), and then remove tailgate kicking plate.

○ : Clip

△ : Pawl

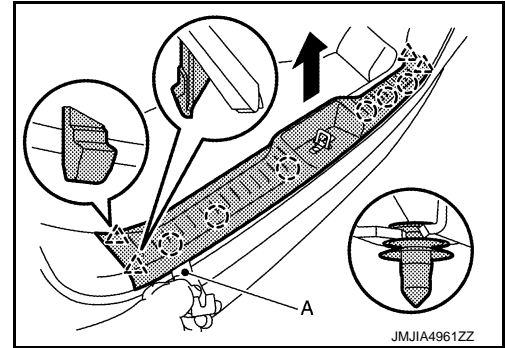

INSTALLING

Note the following item, and install in the reverse order of removal.

CAUTION:

- When installing, check in advance that clips are accurately aligned with the holes on body panel side, and then install by pressing in.
- When pressing in clips located at each end, hold each end of portion (A) toward rear panel.

○ : Clip

↶ : Vehicle front

- After installation, check that protrusion on rear surface of portion (B) is hooked to slit of luggage floor box.

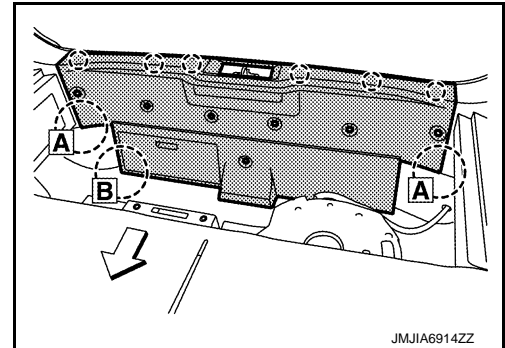

CABLE COVER

CABLE COVER : Removal and Installation

INFOID:000000009650299

CAUTION:

- When removing, always use a remover tool that is made of plastic to prevent damage to the parts.
- Never damage the body.

REMOVAL

1. Remove luggage floor rear board. Refer to [INT-40, "LUGGAGE FLOOR REAR BOARD : Removal and Installation"](#).

LUGGAGE FLOOR TRIM

< REMOVAL AND INSTALLATION >

2. Disengage cable cover fixing clips, and magic fastener using a remover tool (A), and then remove cable cover.

 : Clip

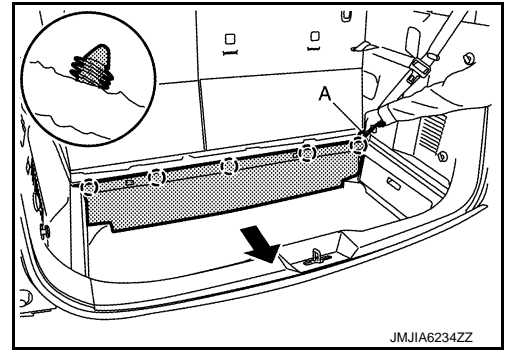

INSTALLING

Note the following item, and install in the reverse order of removal.

CAUTION:

Replace cable cover with a new part after removal. Never reuse cable cover.

LUGGAGE FLOOR FRONT BOARD

LUGGAGE FLOOR FRONT BOARD : Removal and Installation

INFOID:000000009650300

CAUTION:

Never damage the body.

REMOVAL

1. Third seat tilt seatback forward.
2. Remove luggage floor rear board. Refer to [INT-40, "LUGGAGE FLOOR REAR BOARD : Removal and Installation"](#).
3. Remove cable cover. Refer to [INT-41, "CABLE COVER : Removal and Installation"](#).
4. Disengage fixing clips of luggage floor front board using long-nose pliers (A) while lifting up luggage floor front board, and then remove luggage floor front board.

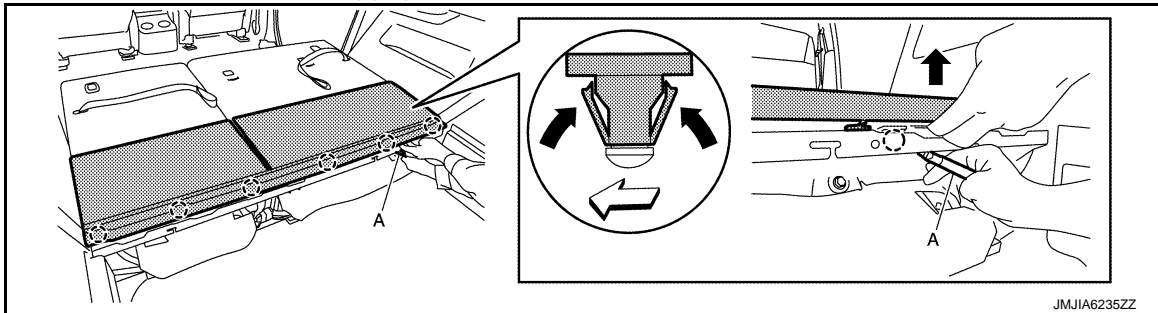

 : Clip

 : Vehicle front

INSTALLING

Note the following item, and install in the reverse order of removal.

CAUTION:

When installing, check in advance that clips are accurately aligned with the holes on luggage floor front bracket side, and then install by pressing in.

LUGGAGE FLOOR FRONT BRACKET

LUGGAGE FLOOR FRONT BRACKET : Removal and Installation

INFOID:000000009650301

CAUTION:

Never damage the body.

REMOVE

1. Remove luggage floor front board. Refer to [INT-42, "LUGGAGE FLOOR FRONT BOARD : Removal and Installation"](#).

LUGGAGE FLOOR TRIM

< REMOVAL AND INSTALLATION >

- Remove luggage floor front bracket fixing bolts (A), and then remove luggage floor front bracket.

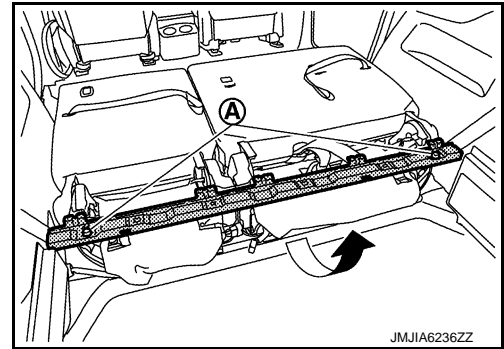

INSTALLATION

Install in the reverse order of removal.

LUGGAGE SIDE LOWER FINISHER

LUGGAGE SIDE LOWER FINISHER : Removal and Installation

INFOID:000000009650302

CAUTION:

- When removing, always use a remover tool that is made of plastic to prevent damage to the parts.
- Never damage the body.
- Be careful not to damage when removing or installing, because opening portion of third roll sunshade is fragile and clips are damaged easily.

REMOVAL

- Remove tailgate kicking plate. Refer to [INT-40. "TAILGATE KICKING PLATE : Removal and Installation"](#).
- Remove third seat. Refer to [SE-125. "Removal and Installation"](#).
- Remove rear kicking plate. Refer to [INT-22. "KICKING PLATE : Removal and Installation"](#).
- Remove rear body side welt. Refer to [INT-23. "BODY SIDE WELT : Removal and Installation"](#).
- Slide second seat to the fully forward position. Tilt seatback forward.
- Remove second seat belt and third seat belt outer anchor.
 - Second seat belt outer anchor: Refer to [SB-11. "SEAT BELT RETRACTOR : Removal and Installation"](#).
 - Third seat belt outer anchor: Refer to [SB-16. "SEAT BELT RETRACTOR : Removal and Installation"](#).
- Remove luggage side lid and remove tool.
- Remove net hook.
 - Insert a remover tool (A) into opening of net hook (1), and then push out hook pin (2).
 - Remove net hook.

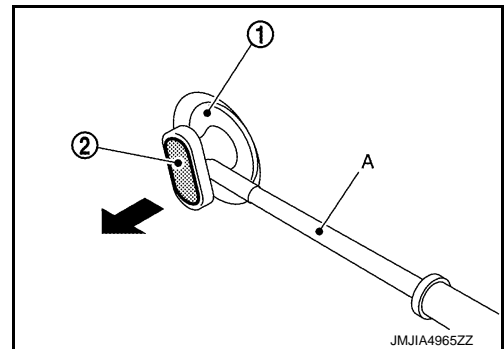

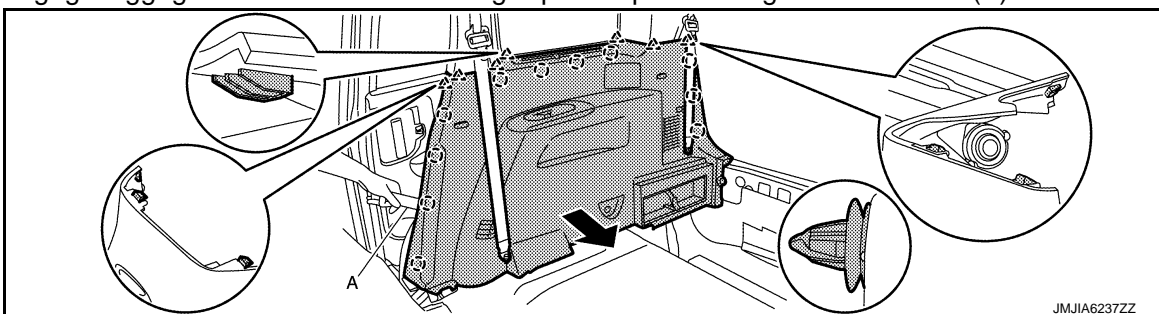

- Disengage luggage side lower finisher fixing clips and pawls using a remover tool (A).



LUGGAGE FLOOR TRIM

< REMOVAL AND INSTALLATION >

-  : Clip
-  : Pawl

10. Disconnect harness connector, and then remove luggage side lower finisher.

CAUTION:

Never hold portions (A) when removing part from the vehicle. Otherwise luggage side floor finisher may be cracked or damaged.

 : Vehicle front

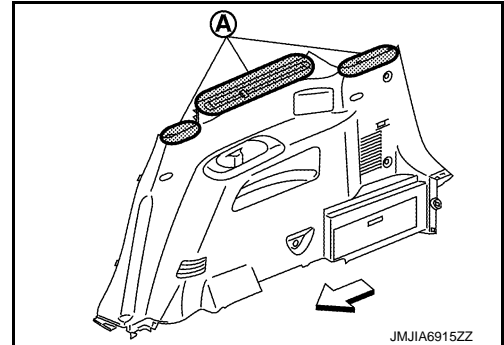

JMJIA6915ZZ

INSTALLING

Note the following item, and install in the reverse order of removal.

CAUTION:

When installing, check in advance that clips are accurately aligned with the holes on body panel side, and then install by pressing in.

THIRD ROLL SUNSHADE

THIRD ROLL SUNSHADE : Exploded View

INFOID:000000009650303

Exploded View

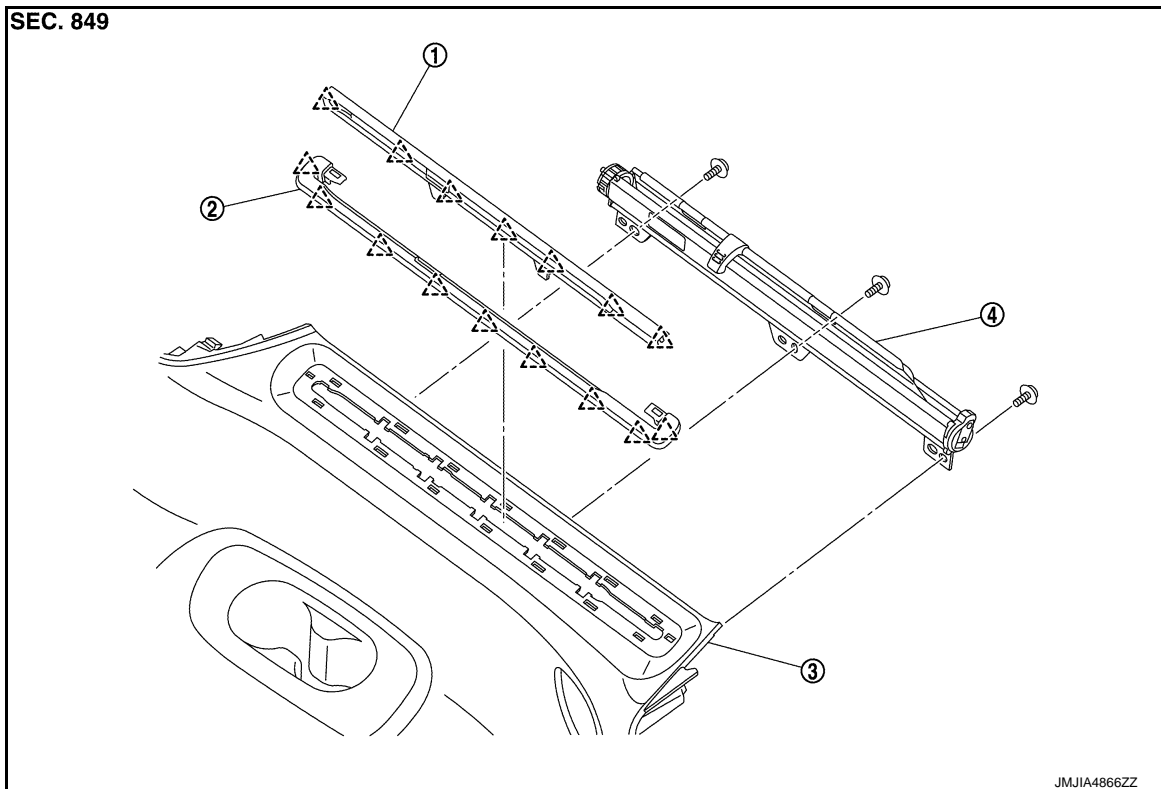

1. Luggage side lower sunshade es-cutcheon B
2. Luggage side lower sunshade es-cutcheon A
3. Luggage side lower finisher
4. Roll sunshade assembly

-  : Pawl

LUGGAGE FLOOR TRIM

< REMOVAL AND INSTALLATION >

THIRD ROLL SUNSHADE : Disassembly and Assembly

INFOID:000000009650304

CAUTION:

- When removing, always use a remover tool that is made of plastic to prevent damage to the parts.
- Never damage the luggage side lower finisher.
- Be careful not to damage when removing or installing, because opening portion of third roll sunshade is fragile and clips are damaged easily.

DISASSEMBLY

1. Remove luggage side lower finisher. Refer to [INT-43, "LUGGAGE SIDE LOWER FINISHER : Removal and Installation"](#).
2. Disengage luggage side lower sunshade escutcheon A and B fixing pawls using a remover tool (A), and then remove luggage side lower sunshade escutcheon A and B.

 : Pawl

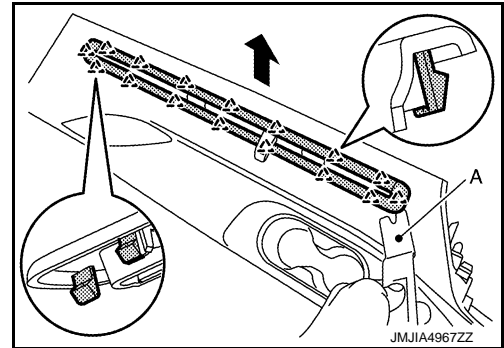

3. Remove third roll sunshade fixing screws (A).
4. Pull lower side of third roll sunshade forward, disengage pin, and then lower third roll sunshade to remove.

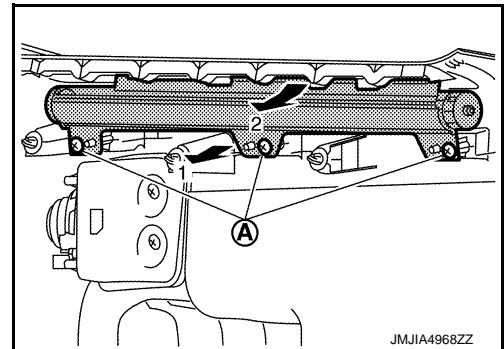

ASSEMBLY

Assembly in the reverse order of disassembly.

LUGGAGE FLOOR BOX

LUGGAGE FLOOR BOX : Removal and Installation

INFOID:000000009650305

CAUTION:

- When removing, always use a remover tool that is made of plastic to prevent damage to the parts.
- Never damage the body.

REMOVAL

1. Remove tailgate kicking plate. Refer to [INT-40, "TAILGATE KICKING PLATE : Removal and Installation"](#).
2. Remove third seat. Refer to [SE-125, "Removal and Installation"](#).
3. Remove luggage floor center board and luggage floor front box. (with BOSE audio)
4. Remove BOSE amp.
 - BOSE audio without navigation: Refer to [AV-407, "Removal and Installation"](#).
 - BOSE audio with navigation: Refer to [AV-613, "Removal and Installation"](#).
5. Remove woofer.
 - BOSE audio without navigation: Refer to [AV-414, "Removal and Installation"](#).
 - BOSE audio with navigation: Refer to [AV-620, "Removal and Installation"](#).

LUGGAGE FLOOR TRIM

< REMOVAL AND INSTALLATION >

6. Pull up carpet, and then remove fixing grommet (B) on the front side of luggage floor box using a remover tool (A).

← : Vehicle front

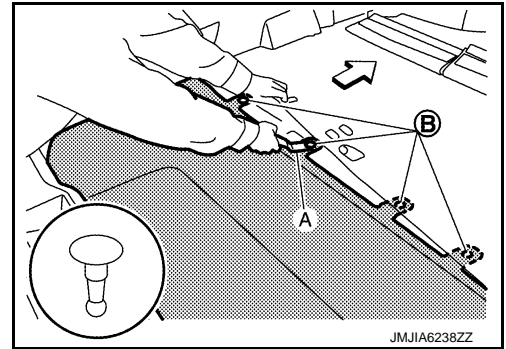

7. Remove fixing clips (A) on the rear side of luggage floor box, and then remove luggage floor box toward vehicle upper while disconnecting pinching to luggage side lower finisher.

← : Vehicle front

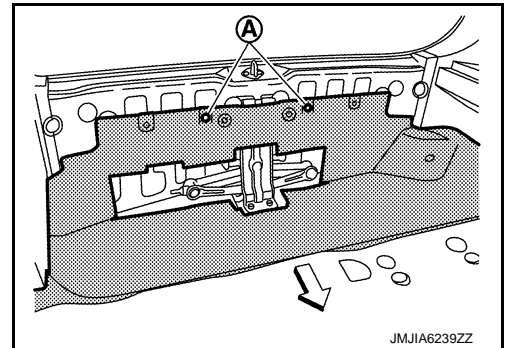

INSTALLING

Install in the reverse order of removal.

BACK DOOR TRIM

< REMOVAL AND INSTALLATION >

BACK DOOR TRIM

Exploded View

INFOID:000000009650306

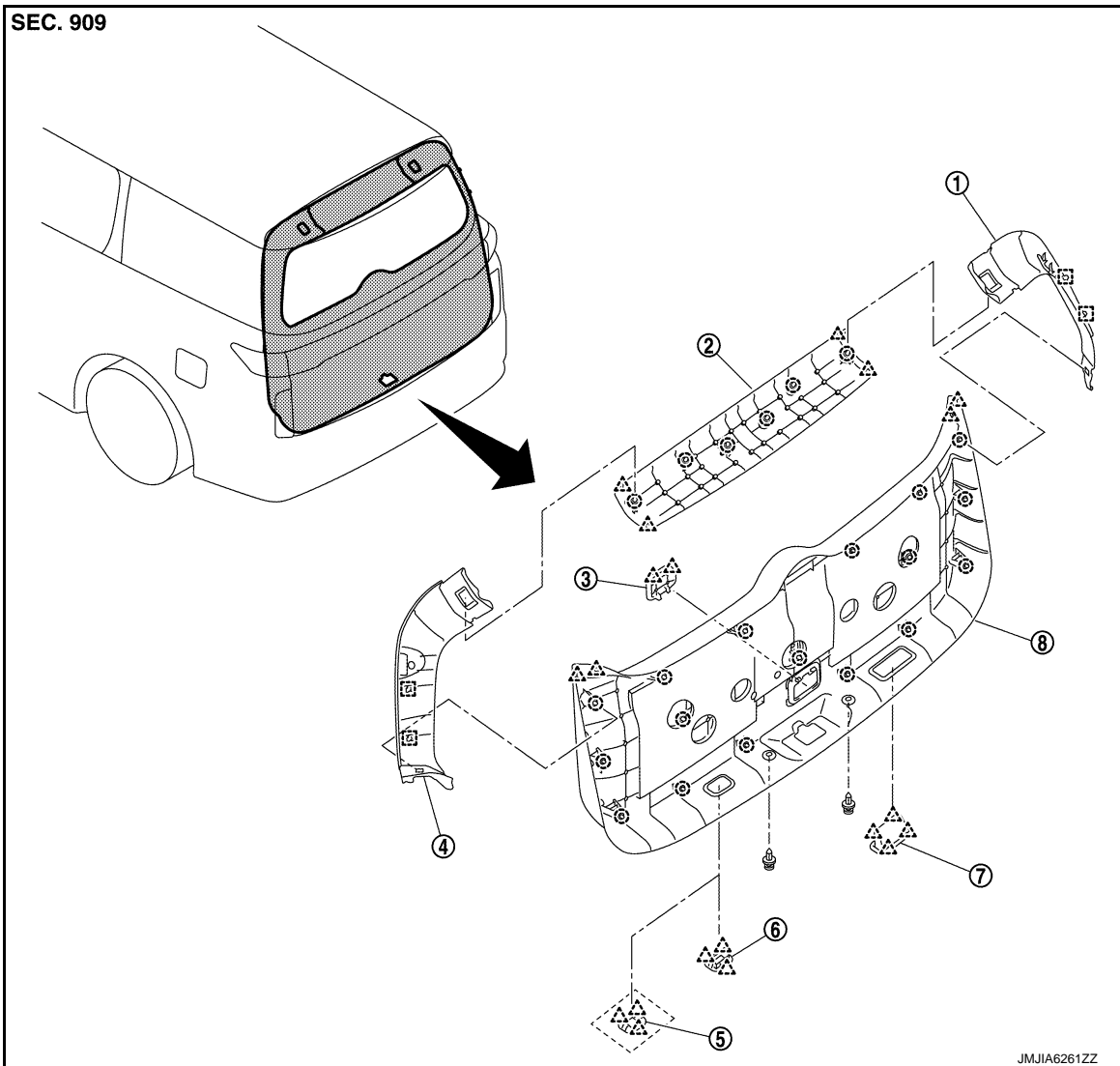

- | | | |
|-------------------------------|--|---|
| 1. Back door side finisher RH | 2. Back door upper garnish | 3. Emergency lid |
| 4. Back door side finisher LH | 5. Back door lower finisher cap
(without automatic back door) | 6. Automatic back door close switch
finisher |
| 7. Back door pull handle | 8. Back door lower finisher | |

○ : Clip

△ : Pawl

□ : Metal clip

BACK DOOR PULL HANDLE

BACK DOOR PULL HANDLE : Removal and Installation

INFOID:000000009650307

CAUTION:

- When removing, always use a remover tool that is made of plastic to prevent damage to the parts.
- Never damage the back door panel.

REMOVAL

1. Fully open the back door.

A
B
C
D
E
F
G
H
I
INT
K
L
M
N
O
P

BACK DOOR TRIM

< REMOVAL AND INSTALLATION >

2. Disengage back door pull handle fixing pawls using a remover tool (A), and then remove back door pull handle.

CAUTION:

Apply protective tape (B) on the part to protect it from damage.

 : Pawl

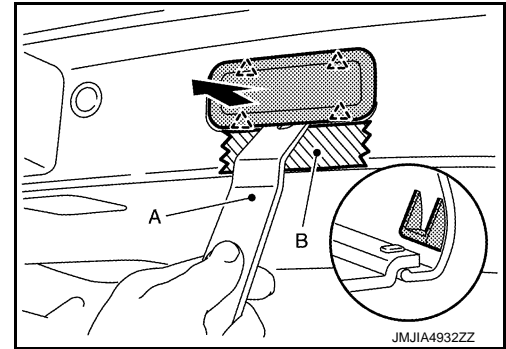

INSTALLING

Install in the reverse order of removal.

BACK DOOR LOWER FINISHER

BACK DOOR LOWER FINISHER : Removal and Installation

INFOID:000000009650308

CAUTION:

- When removing, always use a remover tool that is made of plastic to prevent damage to the parts.
- Never damage the back door panel.

REMOVAL

1. Fully open the back door.
2. Remove back door pull handle. Refer to [INT-47, "BACK DOOR PULL HANDLE : Removal and Installation"](#).
3. Remove automatic back door close switch finisher (1) and automatic back door close switch (2) as a set. (with automatic back door)
- a. Disengage automatic back door close switch finisher fixing pawls using a remover tool (A).

CAUTION:

Apply protective tape (B) on the part to protect it from damage.

 : Pawl

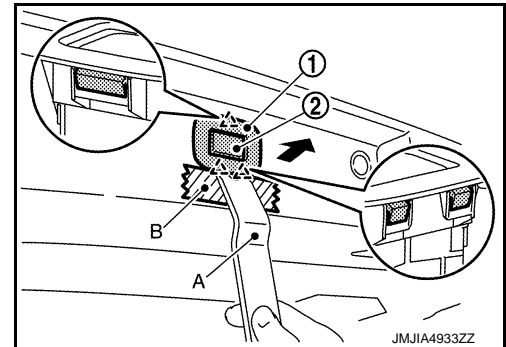

- b. Disconnect harness connector, and then remove automatic back door close switch finisher and automatic back door close switch as a set.

NOTE:

Remove automatic back door close switch: Refer to [DLK-498, "Removal and Installation"](#).

4. Remove back door lower finisher fixing clips (A).

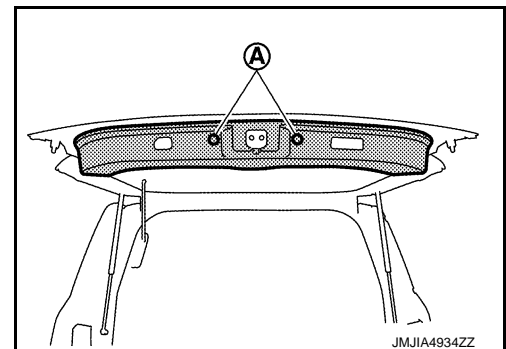

BACK DOOR TRIM

< REMOVAL AND INSTALLATION >

- Disengage back door lower finisher fixing clips and pawls, and then remove back door lower finisher.

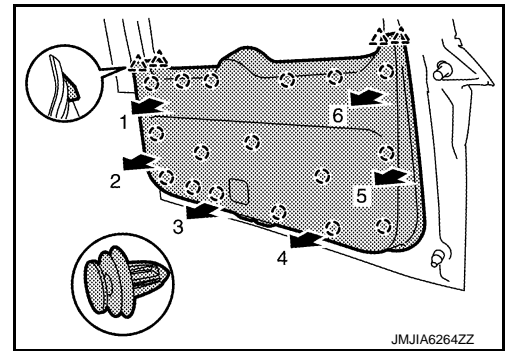
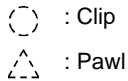

INSTALLING

Note the following item, and install in the reverse order of removal.

CAUTION:

When installing, check in advance that clips are accurately aligned with the holes on back door panel side, and then install by pressing in.

BACK DOOR UPPER FINISHER

BACK DOOR UPPER FINISHER : Removal and Installation

INFOID:000000009650309

CAUTION:

- When removing, always use a remover tool that is made of plastic to prevent damage to the parts.
- Never damage the back door panel.

REMOVAL

- Fully open the back door.
- Disengage back door upper finisher fixing clips and pawls using a remover tool (A), and then remove back door upper finisher.

CAUTION:

Apply protective tape (B) on the part to protect it from damage.

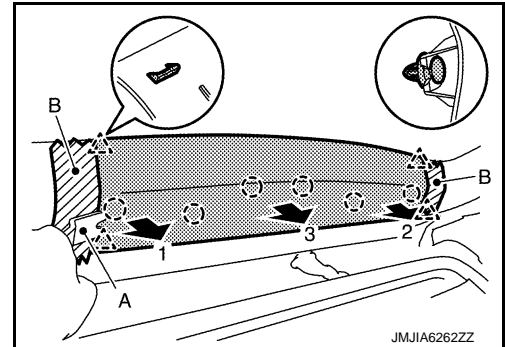
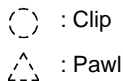

INSTALLING

Note the following item, and install in the reverse order of removal.

CAUTION:

When installing, check in advance that clips are accurately aligned with the holes on back door panel side, and then install by pressing in.

BACK DOOR SIDE FINISHER

BACK DOOR SIDE FINISHER : Removal and Installation

INFOID:000000009650310

CAUTION:

- When removing, always use a remover tool that is made of plastic to prevent damage to the parts.
- Never damage the back door panel.

REMOVAL

- Fully open the back door.
- Remove back door lower finisher. Refer to [INT-48. "BACK DOOR LOWER FINISHER : Removal and Installation"](#).
- Remove back door upper finisher. Refer to [INT-49. "BACK DOOR UPPER FINISHER : Removal and Installation"](#).
- Remove back door support rod. (with automatic back door) Refer to [DLK-477. "BACK DOOR SUPPORT ROD : Removal and Installation"](#).

BACK DOOR TRIM

< REMOVAL AND INSTALLATION >

5. Disengage back door side finisher fixing metal clips using a remover tool (A), and then remove back door side finisher.

CAUTION:

Apply protective tape (B) on the part to protect it from damage.

 : Metal clip

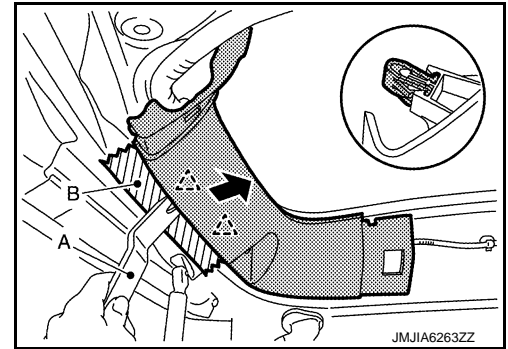

INSTALLING

Note the following item, and install in the reverse order of removal.

CAUTION:

When installing, check in advance that metal clips are accurately aligned with the holes on back door panel side, and then install by pressing in.

EMERGENCY LID

EMERGENCY LID : Removal and Installation

INFOID:000000009650311

CAUTION:

When removing, always use a remover tool that is made of plastic to prevent damage to the parts.

REMOVAL

1. Fully open the back door.
2. Insert a remover tool (A) into cutout portion of emergency lid, disengage pawls, and then remove emergency lid.

CAUTION:

Apply protective tape (B) on the part to protect it from damage.

 : Pawl

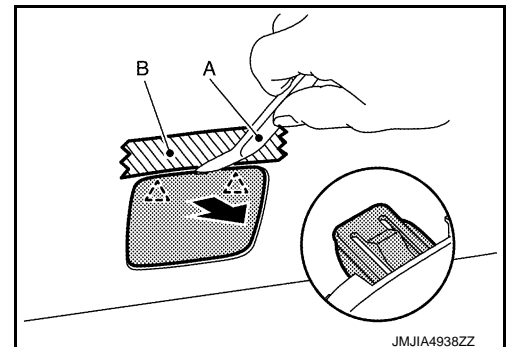

INSTALLING

Install in the reverse order of removal.