

SECTION **MIR**
MIRRORS

A
B
C
D
E
F
G
H
I
J
K
MIR
M
N
O
P

CONTENTS

WITH ADP	List of ECU Reference	12
PRECAUTION	WIRING DIAGRAM	13
PRECAUTIONS	DOOR MIRROR SYSTEM	13
Precaution for Supplemental Restraint System (SRS) "AIR BAG" and "SEAT BELT PRE-TENSIONER"	Wiring Diagram	13
Precautions for Removing Battery Terminal	AUTO ANTI-DAZZLING INSIDE MIRROR SYSTEM	20
PREPARATION	Wiring Diagram	20
PREPARATION	SYMPTOM DIAGNOSIS	22
Special Service Tools	REVERSE INTERLOCK DOOR MIRROR DOES NOT OPERATE	22
Commercial Service Tools	Diagnosis Procedure	22
SYSTEM DESCRIPTION	SQUEAK AND RATTLE TROUBLE DIAGNOSES	23
COMPONENT PARTS	Work Flow	23
Component Parts Location	Inspection Procedure	25
Door Mirror Remote Control Switch	Diagnostic Worksheet	27
Door Mirror	REMOVAL AND INSTALLATION	29
Auto Anti-dazzling Inside Mirror	INSIDE MIRROR	29
SYSTEM	Exploded View	29
DOOR MIRROR SYSTEM	Removal and Installation	29
DOOR MIRROR SYSTEM : System Description	DOOR MIRROR	31
DOOR MIRROR SYSTEM : Schematic	Exploded View	31
AUTO ANTI-DAZZLING INSIDE MIRROR SYSTEM	DOOR MIRROR ASSEMBLY	33
AUTO ANTI-DAZZLING INSIDE MIRROR SYSTEM : System Description	DOOR MIRROR ASSEMBLY : Removal and Installation	33
DIAGNOSIS SYSTEM (DRIVER SEAT CONTROL UNIT)	DOOR MIRROR ASSEMBLY : Disassembly and Assembly	35
CONSULT Function	GLASS MIRROR	37
ECU DIAGNOSIS INFORMATION	GLASS MIRROR : Removal and Installation	37
DRIVER SEAT CONTROL UNIT, AUTOMATIC DRIVE POSITIONER CONTROL UNIT	DOOR MIRROR COVER	38

PRECAUTION

PRECAUTIONS

Precaution for Supplemental Restraint System (SRS) "AIR BAG" and "SEAT BELT PRE-TENSIONER"

INFOID:000000009652697

The Supplemental Restraint System such as "AIR BAG" and "SEAT BELT PRE-TENSIONER", used along with a front seat belt, helps to reduce the risk or severity of injury to the driver and front passenger for certain types of collision. This system includes seat belt switch inputs and dual stage front air bag modules. The SRS system uses the seat belt switches to determine the front air bag deployment, and may only deploy one front air bag, depending on the severity of a collision and whether the front occupants are belted or unbelted. Information necessary to service the system safely is included in the "SRS AIR BAG" and "SEAT BELT" of this Service Manual.

WARNING:

Always observe the following items for preventing accidental activation.

- To avoid rendering the SRS inoperative, which could increase the risk of personal injury or death in the event of a collision that would result in air bag inflation, all maintenance must be performed by an authorized NISSAN/INFINITI dealer.
- Improper maintenance, including incorrect removal and installation of the SRS, can lead to personal injury caused by unintentional activation of the system. For removal of Spiral Cable and Air Bag Module, see "SRS AIR BAG".
- Never use electrical test equipment on any circuit related to the SRS unless instructed to in this Service Manual. SRS wiring harnesses can be identified by yellow and/or orange harnesses or harness connectors.

PRECAUTIONS WHEN USING POWER TOOLS (AIR OR ELECTRIC) AND HAMMERS

WARNING:

Always observe the following items for preventing accidental activation.

- When working near the Air Bag Diagnosis Sensor Unit or other Air Bag System sensors with the ignition ON or engine running, never use air or electric power tools or strike near the sensor(s) with a hammer. Heavy vibration could activate the sensor(s) and deploy the air bag(s), possibly causing serious injury.
- When using air or electric power tools or hammers, always switch the ignition OFF, disconnect the battery, and wait at least 3 minutes before performing any service.

Precautions for Removing Battery Terminal

INFOID:000000009890716

- When removing the 12V battery terminal, turn OFF the ignition switch and wait at least 30 seconds.

NOTE:

ECU may be active for several tens of seconds after the ignition switch is turned OFF. If the battery terminal is removed before ECU stops, then a DTC detection error or ECU data corruption may occur.

- For vehicles with the 2-batteries, be sure to connect the main battery and the sub battery before turning ON the ignition switch.

NOTE:

If the ignition switch is turned ON with any one of the terminals of main battery and sub battery disconnected, then DTC may be detected.

- After installing the 12V battery, always check "Self Diagnosis Result" of all ECUs and erase DTC.

NOTE:

The removal of 12V battery may cause a DTC detection error.

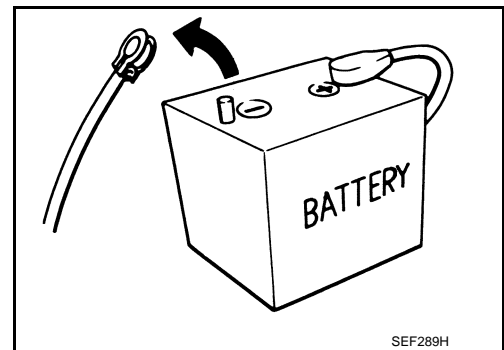

A
B
C
D
E
F
G
H
I
J
K
L
M
N
O
P

MIR

PREPARATION

< PREPARATION >

[WITH ADP]

PREPARATION

PREPARATION

Special Service Tools

INFOID:000000009652698

The actual shapes of Kent-Moore tools may differ from those of special service tools illustrated here.

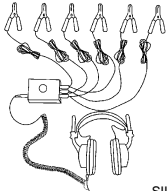
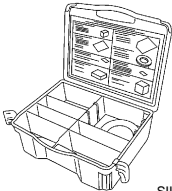
Tool number (Kent-Moore No.) Tool name	Description
<p>(J-39570) Chassis ear</p> <div style="text-align: center;">  <p style="font-size: small;">SIIA0993E</p> </div>	<p>Locates the noise</p>
<p>(J-50397) NISSAN Squeak and Rattle Kit</p> <div style="text-align: center;">  <p style="font-size: small;">SIIA0994E</p> </div>	<p>Repairs the cause of noise</p>

Commercial Service Tools

INFOID:000000009652699

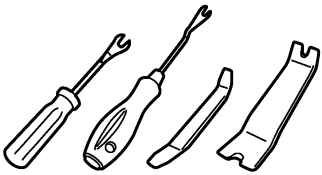
Tool name	Description
<p>Remover tool</p> <div style="text-align: center;">  <p style="font-size: small;">JMKIA3050ZZ</p> </div>	<p>Remove the clip, pawl and metal clip</p>

COMPONENT PARTS

< SYSTEM DESCRIPTION >

[WITH ADP]

SYSTEM DESCRIPTION

COMPONENT PARTS

Component Parts Location

INFOID:000000009652700

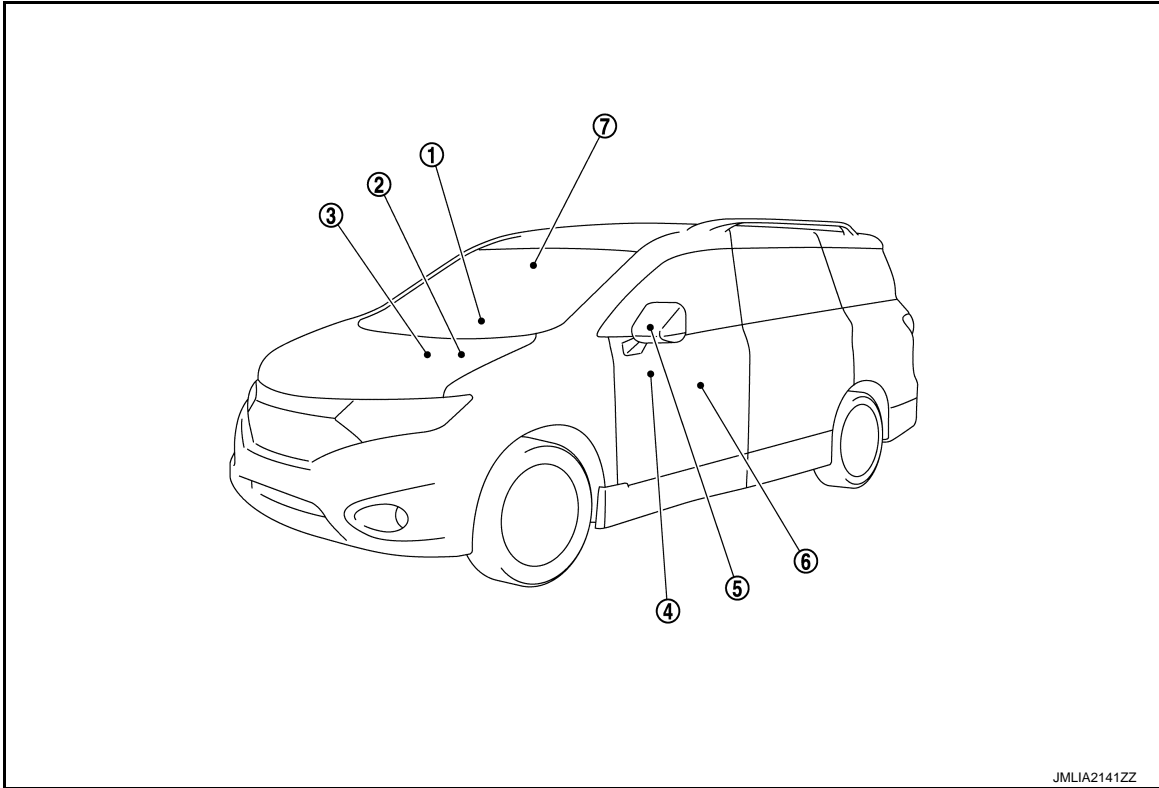

JMLIA2141ZZ

No.	Component parts	Function
1.	BCM	The ignition switch signal (ACC/ON) is transmitted to driver seat control unit via CAN communication. Refer to BCS-4, "BODY CONTROL SYSTEM : Component Parts Location" for detailed installation location.
2.	Automatic drive positioner control unit	Door mirror is supplied with power after receiving the input of mirror switch and changeover switch. Refer to ADP-8, "Automatic Drive Positioner Control Unit" for detailed installation location.
3.	TCM	The CVT shift position signal is transmitted to driver seat control unit via CAN communication. Refer to TM-10, "CVT CONTROL SYSTEM : Component Parts Location" for detailed installation location.
4.	Door mirror remote control switch	Refer to MIR-5, "Door Mirror Remote Control Switch" .
5.	Door mirror (driver side)	Refer to MIR-6, "Door Mirror" .
6.	Driver seat control unit	The ignition switch signal (ACC/ON) is transmitted to automatic drive positioner control unit via UART communication. Refer to ADP-8, "Driver Seat Control Unit" for detailed installation location.
7.	Auto anti-dazzling inside mirror	Refer to MIR-6, "Auto Anti-dazzling Inside Mirror" .

Door Mirror Remote Control Switch

INFOID:000000009652701

MIRROR SWITCH

It transmits mirror face adjust operation to automatic drive positioner control unit.

CHANGEOVER SWITCH

COMPONENT PARTS

< SYSTEM DESCRIPTION >

[WITH ADP]

It transmits the LH/RH control of door mirror that supplies power to automatic drive positioner control unit.

Door Mirror

INFOID:000000009652702

It makes mirror face operate from side to side and up and down via integrated motor.

Auto Anti-dazzling Inside Mirror

INFOID:000000009652703

It automatically changes the light transmittance according to the brightness of the light from the headlight of the vehicle behind.

SYSTEM

DOOR MIRROR SYSTEM

DOOR MIRROR SYSTEM : System Description

INFOID:000000009652704

SYSTEM DIAGRAM

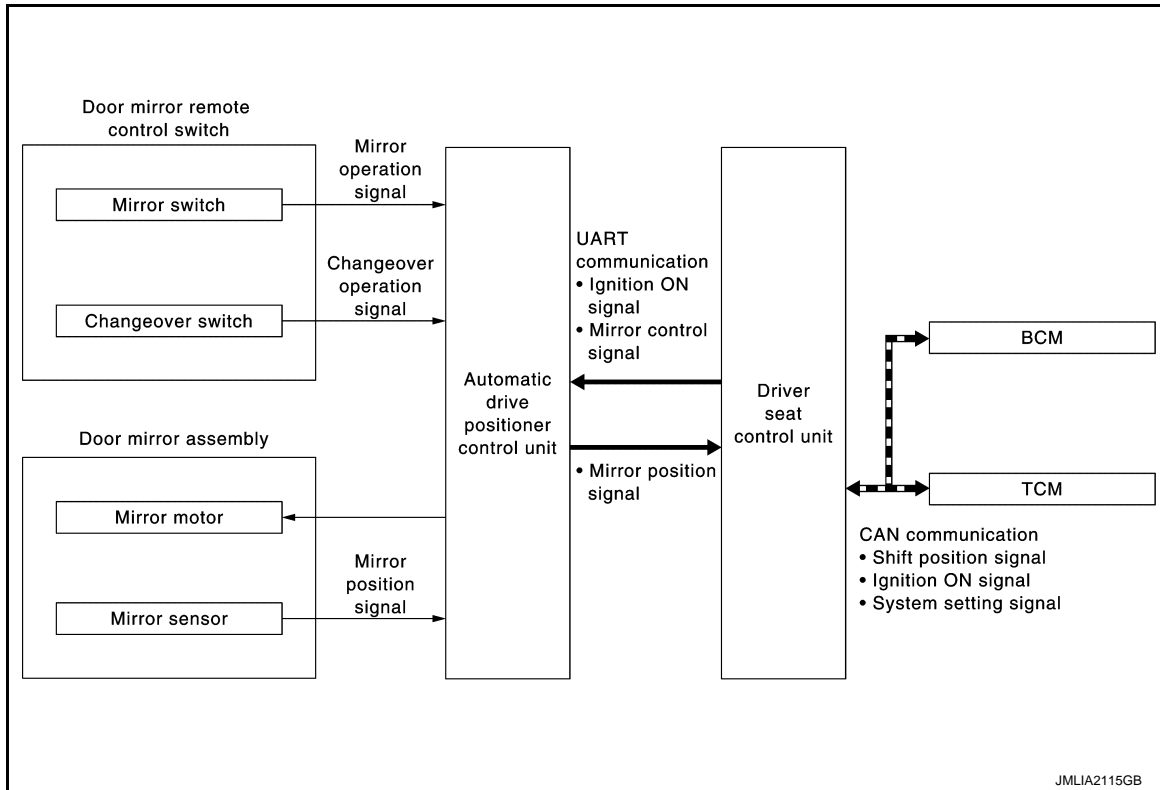

MANUAL FUNCTION

Description

- Automatic drive positioner control unit controls door mirror.
- Automatic drive positioner control unit inputs changeover switch signal and perform the LH/RH control of door mirror motor supplying electric power when changeover switch is operated.
- Automatic drive positioner control unit inputs mirror switch signal and supplies electric power to door mirror.
- The ignition switch signal (ACC/ON) is transmitted from BCM to driver seat control unit via CAN communication and from driver seat control unit to automatic drive positioner control unit via UART communication.

Operation Conditions

If the following conditions are not satisfied, operation is not performed.

- Ignition switch: ON or ACC
- Changeover switch: Select either left or right

REVERSE INTERLOCK DOOR MIRROR SYSTEM

Description

- Select either of the door mirror faces by changeover switch, and then set mirror face downward.
- When ignition switch is ON position and CVT shift selector is in R position, TCM sends the R signal to driver seat control unit.
- The R signal is transmitted to automatic drive positioner control unit from driver seat control unit via UART communication.
- When the R signal is detected, automatic drive positioner control unit activated mirror motor.

Operation Conditions

If the following conditions are not satisfied, operation is not performed.

- Ignition switch: ON
- Changeover switch: Select either left or right
- CVT shift selector: R position

A
B
C
D
E
F
G
H
I
J

K

MIR

M

N

O

P

SYSTEM

< SYSTEM DESCRIPTION >

[WITH ADP]

NOTE:

During the reverse interlock door mirror system, if all of the above conditions are not satisfied, mirror face returns to original angle.

AUTOMATIC DRIVE POSITIONER SYSTEM LINKED OPERATION

Description

Door mirror control is included in automatic drive positioner system. Refer to automatic drive positioner system for more details.

Refer to [ADP-9, "AUTOMATIC DRIVE POSITIONER SYSTEM : System Description"](#).

DOOR MIRROR SYSTEM : Schematic

INFOID:000000009652705

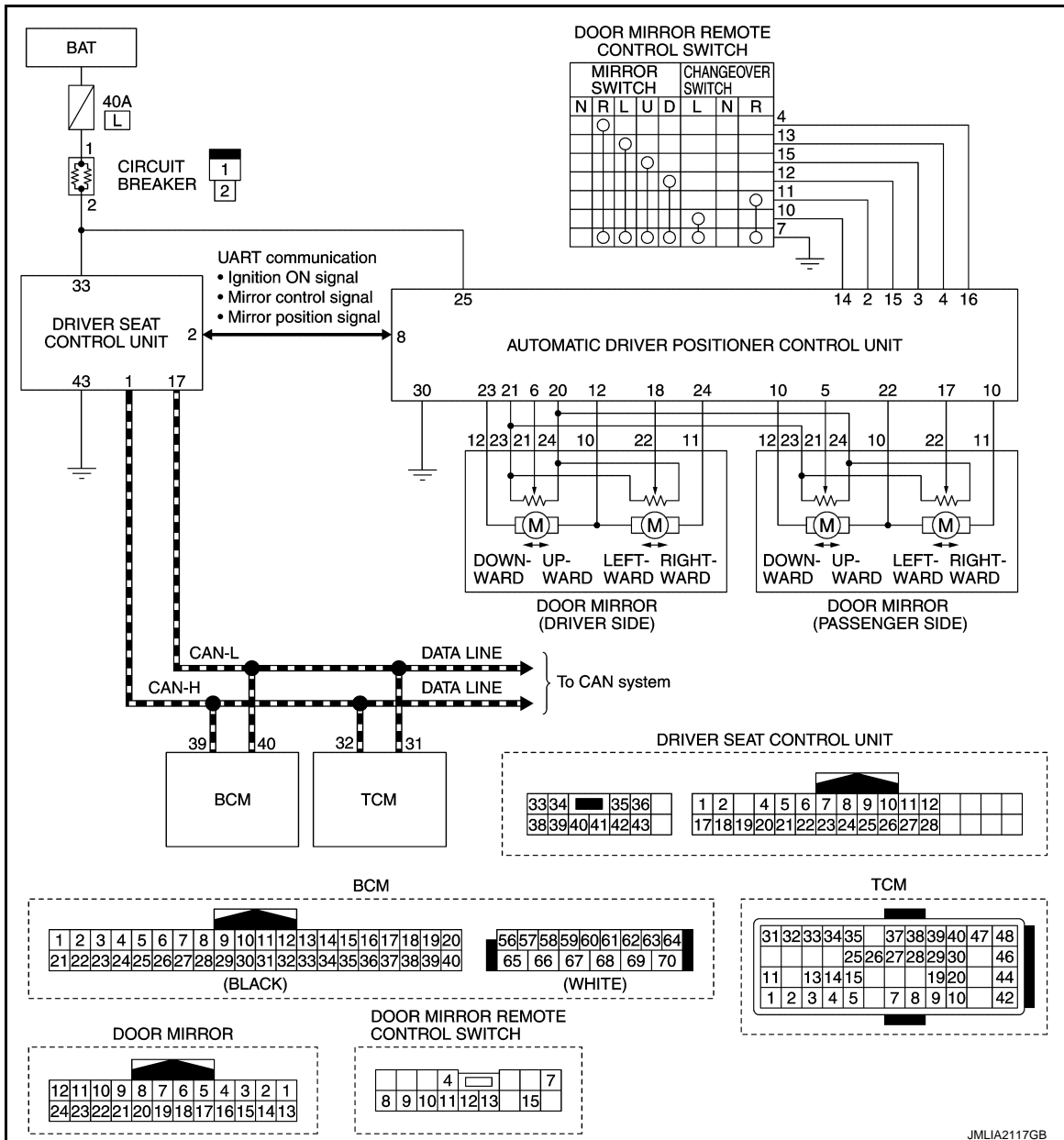

AUTO ANTI-DAZZLING INSIDE MIRROR SYSTEM

AUTO ANTI-DAZZLING INSIDE MIRROR SYSTEM : System Description

INFOID:000000009652706

The sensor built in inside mirror detects the brightness of headlight of the vehicle behind and automatically changes the light transmission to decrease the brightness.

DIAGNOSIS SYSTEM (DRIVER SEAT CONTROL UNIT)

< SYSTEM DESCRIPTION >

[WITH ADP]

DIAGNOSIS SYSTEM (DRIVER SEAT CONTROL UNIT)

CONSULT Function

INFOID:000000009652707

The automatic drive positioner system can be checked and diagnosed for component operation using CONSULT.

APPLICATION ITEMS

Diagnostic mode	Description
Ecu Identification	Displays part numbers of driver seat control unit.
Self Diagnostic Result	Performs self-diagnosis for the auto drive positioner system and displays the results.
Data Monitor	Displays input signals transmitted from various switches and sensors to driver seat control unit in real time.
Active Test	Drives each output unit.
Work support	Changes the setting for each system function.

SELF-DIAGNOSIS RESULTS

Refer to [ADP-30. "DTC Index"](#).

DATA MONITOR

NOTE:

The following table includes information (items) inapplicable to this vehicle. For information (items) applicable to this vehicle, refer to CONSULT display items.

Monitor Item	Unit	Main Signals	Selection From Menu	Contents
STARTER SW	"ON/OFF"	×	×	Ignition key switch ON (START, ON) /OFF (ACC, OFF) status judged from the ignition switch signal.
SET SW	"ON/OFF"	×	×	ON/OFF status judged from the setting switch signal.
MEMORY SW 1	"ON/OFF"	×	×	ON/OFF status judged from the seat memory switch 1 signal.
MEMORY SW 2	"ON/OFF"	×	×	ON/OFF status judged from the seat memory switch 2 signal.
DETENT SW	"ON/OFF"	×	×	The CVT shift selector position "OFF (P position) / ON (other than P position)" judged from the detention switch signal.
STEERING STATUS	"LOCK/UN-LOCK"	×	×	NOTE: This item is indicated, but not monitored.
SLIDE SW-FR	"ON/OFF"	×	×	ON/OFF status judged from the sliding switch (forward) signal.
SLIDE SW-RR	"ON/OFF"	×	×	ON/OFF status judged from the sliding switch (backward) signal.
RECLN SW-FR	"ON/OFF"	×	×	ON/OFF status judged from the reclining switch (forward) signal.
RECLN SW-RR	"ON/OFF"	×	×	ON/OFF status judged from the reclining switch (backward) signal.
LIFT FR SW-UP	"ON/OFF"	×	×	ON/OFF status judged from the lifting switch front (up) signal.
LIFT FR SW-DN	"ON/OFF"	×	×	ON/OFF status judged from the lifting switch front (down) signal.
LIFT RR SW-UP	"ON/OFF"	×	×	ON/OFF status judged from the lifting switch rear (up) signal.
LIFT RR SW-DN	"ON/OFF"	×	×	ON/OFF status judged from the lifting switch rear (down) signal.
MIR CON SW-UP	"ON/OFF"	×	×	ON/OFF status judged from the mirror switch (up) signal.

DIAGNOSIS SYSTEM (DRIVER SEAT CONTROL UNIT)

< SYSTEM DESCRIPTION >

[WITH ADP]

Monitor Item	Unit	Main Signals	Selection From Menu	Contents
MIR CON SW-DN	"ON/OFF"	×	×	ON/OFF status judged from the mirror switch (down) signal.
MIR CON SW-RH	"ON/OFF"	×	×	ON/OFF status judged from the mirror switch (right) signal.
MIR CON SW-LH	"ON/OFF"	×	×	ON/OFF status judged from the mirror switch (left) signal.
MIR CHNG SW-R	"ON/OFF"	×	×	ON/OFF status judged from the door mirror remote control switch (switching to right) signal.
MIR CHNG SW-L	"ON/OFF"	×	×	ON/OFF status judged from the door mirror remote control switch (switching to left) signal.
VEHICLE SPEED	—	×	×	Display the vehicle speed signal received from combination meter by numerical value [km/h].
P RANG SW CAN	"ON/OFF"	×	×	ON/OFF status judged from the P range switch signal.
R RANGE (CAN)	"ON/OFF"	×	×	ON/OFF status judged from the R range switch signal.
DOOR SW-FL	"ON/OFF"	×	×	ON/OFF status judged from the front door switch (driver side) signal.
DOOR SW-FR	"ON/OFF"	×	×	ON/OFF status judged from the door switch (front passenger side) signal.
IGN ON SW	"ON/OFF"	×	×	ON/OFF status judged from the ignition switch signal.
ACC ON SW	"ON/OFF"	×	×	ON/OFF status judged from the ACC switch signal.
KEY ON SW	"ON/OFF"	×	×	ON/OFF status judged from the key on switch signal.
KEYLESS ID	—	×	×	Key ID status judged from the key ID signal.
KYLS DR UNLK	"ON/OFF"	×	×	ON/OFF status judged from the driver side door unlock actuator output switch signal.
VHCL SPEED (ABS)	"ON/OFF"	×	×	ON/OFF status judged from vehicle speed signal.
HANDLE	"RHD/LHD"	×	×	RHD/LHD status judged from handle position signal.
TRANSMISSION	"AT or CVT/MT"	×	×	AT or CVT/MT status judged from transmission.
SLIDE PULSE	—	—	×	Value (32768) when battery connections are standard. If it moves backward, the value increases. If it moves forward, the value decreases.
RECLN PULSE	—	—	×	Value (32768) when battery connections are standard. If it moves backward, the value increases. If it moves forward, the value decreases.
LIFT FR PULSE	—	—	×	Value (32768) when battery connections are standard. If it moves DOWN, the value increases. If it moves UP, the value decreases.
LIFT RR PULSE	—	—	×	Value (32768) when battery connections are standard. If it moves DOWN, the value increases. If it moves UP, the value decreases.
MIR/SEN RH U-D	"V"	—	×	Voltage input from door mirror sensor (passenger side) up/down is displayed.
MIR/SEN RH R-L	"V"	—	×	Voltage input from door mirror sensor (passenger side) left/right is displayed.
MIR/SEN LH U-D	"V"	—	×	Voltage input from door mirror sensor (driver side) up/down is displayed.
MIR/SEN LH R-L	"V"	—	×	Voltage input from door mirror sensor (driver side) left/right is displayed.

ACTIVE TEST

CAUTION:

When driving vehicle, do not perform active test.

DIAGNOSIS SYSTEM (DRIVER SEAT CONTROL UNIT)

< SYSTEM DESCRIPTION >

[WITH ADP]

Test item	Description
SEAT SLIDE	Activates/deactivates the sliding motor.
SEAT RECLINING	Activates/deactivates the reclining motor.
SEAT LIFTER FR	Activates/deactivates the lifting motor (front).
SEAT LIFTER RR	Activates/deactivates the lifting motor (rear).
MIRROR MOTOR RH	Activates/deactivates the mirror motor (passenger side).
MIRROR MOTOR LH	Activates/deactivates the mirror motor (driver side).
MEMORY SW INDCTR	Turns ON/OFF the memory indicator.

WORK SUPPORT

Work item	Content	Item
SEAT SLIDE VOLUME SET	The amount of seat sliding for entry/exit assist can be selected from 3 items.	40 mm
		80 mm
		150 mm
EXIT SEAT SLIDE SETTING	Entry/exit assist (seat) can be selected: ON (operated) – OFF (not operated)	ON
		OFF

A
B
C
D
E
F
G
H
I
J
K

MIR

M
N
O
P

DRIVER SEAT CONTROL UNIT, AUTOMATIC DRIVE POSITIONER CONTROL UNIT

< ECU DIAGNOSIS INFORMATION >

[WITH ADP]

ECU DIAGNOSIS INFORMATION

DRIVER SEAT CONTROL UNIT, AUTOMATIC DRIVE POSITIONER CONTROL UNIT

List of ECU Reference

INFOID:000000009652708

ECU	Reference
DRIVER SEAT CONTROL UNIT	ADP-25, "Reference Value"
	ADP-30, "Fail-safe"
	ADP-30, "DTC Index"
AUTOMATIC DRIVE POSITIONER CONTROL UNIT	ADP-31, "Reference Value"

DOOR MIRROR SYSTEM

[WITH ADP]

< WIRING DIAGRAM >

WIRING DIAGRAM

DOOR MIRROR SYSTEM

Wiring Diagram

INFOID:000000009652709

DOOR MIRROR (WITH AUTOMATIC DRIVE POSITIONER)

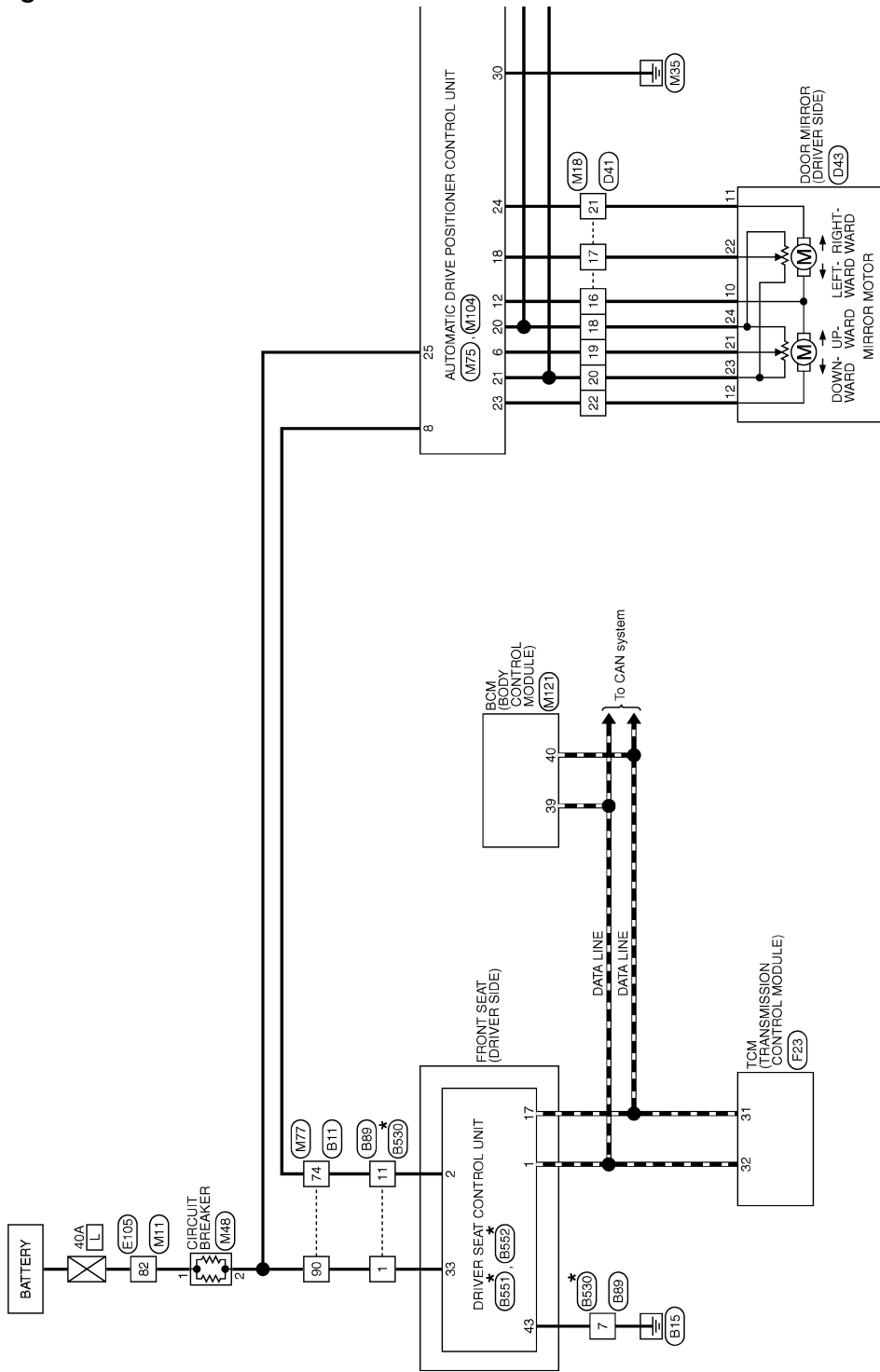

*: This connector is not shown in "Harness Layout".

2010/12/13

JCLWA5123GB

A
B
C
D
E
F
G
H
I
J
K
L
M
N
O
P

MIR

DOOR MIRROR SYSTEM

< WIRING DIAGRAM >

[WITH ADP]

DOOR MIRROR (WITH AUTOMATIC DRIVE POSITIONER)

Connector No.	B11
Connector Name	WIRE TO WIRE
Connector Type	TH180MK-CS19

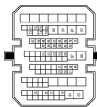

Terminal No.	Color Of Wire	Signal Name [Specification]
10	LG	
12	P	
13	T/P	
15	L	
28	GR	
30	W	
31	BR	
37	SHIELD	
38	R/L	
39	B	
40	R/W	
51	O	
52	B/P	
53	V	
54	P	
55	H	
57	Y	
58	L	
59	V	
60	O	
61	B	
62	W	
63	Y	
64	W	
65	R	
66	SHIELD	
67	B	
68	W	
69	SHIELD	
70	B/R	
71	B/R	
72	P	
74	BR	
75	SB	
77	V	

78	LG	--
79	R	--
80	R	--
81	SR	--
82	V	--
87	BR	--
88	P	--
89	BR	--
90	LG	-- [Without automatic drive positioner]
90	P	-- [With automatic drive positioner]
91	O	--
92	G	--

Connector No.	BB9
Connector Name	WIRE TO WIRE
Connector Type	NS16FW-CS

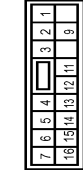

Terminal No.	Color Of Wire	Signal Name [Specification]
1	P	
2	SR	
3	SR	
4	R	
5	V	
6	GR	
7	B	
9	G	
11	BR	
12	P	
13	L	
14	LG	
15	O	
18	B	

Connector No.	B530
Connector Name	WIRE TO WIRE
Connector Type	NS16MW-CS

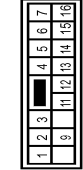

Terminal No.	Color Of Wire	Signal Name [Specification]
1	R	
2	R/W	
3	R/W	
4	W/R	
5	W/L	
6	Y	
7	LG	
9	P	
11	R	
12	V	
13	R/Y	
14	G	
15	P	
18	L/P	

Connector No.	B551
Connector Name	DRIVER SEAT CONTROL UNIT
Connector Type	NS12FW-CS



Terminal No.	Color Of Wire	Signal Name [Specification]
33	R	BAT
34	B	SLIDE MOTOR (BACKWARD)
35	G	RECLINER MOTOR (FORWARD)
36	L	FRONT LIFTER MOTOR (DOWNWARD)
38	GR	SLIDE MOTOR (FORWARD)

39	Y	RECLINER MOTOR (BACKWARD)
40	W	REAR LIFTER MOTOR (DOWNWARD)
41	V	REAR LIFTER MOTOR (UPWARD)
42	P/B	REAR LIFTER MOTOR (DOWNWARD)
43	LG	GROUND

Connector No.	B552
Connector Name	DRIVER SEAT CONTROL UNIT
Connector Type	TH132FW-NH



Terminal No.	Color Of Wire	Signal Name [Specification]
1	R/Y	CAN-H
2	R	UART (TX/RX)
4	R/L	PULSE (RECLINER)
6	R/W	ADDRESS 2
7	R/G	IND-2
8	SB	SLIDE SW (BACKWARD)
9	L	RECLINER SW (BACKWARD)
10	L/B	FRONT LIFTER SW (DOWNWARD)
11	L/R	FRONT LIFTER SW (UPWARD)
12	L/R	SENSOR (POWER SUPPLY)
17	V	CAN-L
18	B/W	PULSE (SLIDE)
19	B/R	PULSE (FRONT LIFTER)
20	B/L	PULSE (REAR LIFTER)
22	W/L	ADDRESS 1
23	W/R	IND-1
24	V/W	SLIDE SW (FORWARD)
25	Y/B	RECLINER SW (FORWARD)
26	Y/R	FRONT LIFTER SW (UPWARD)
27	Y/L	REAR LIFTER SW (UPWARD)
28	G	SET SW

A
B
C
D
E
F
G
H
I
J
K
L
M
N
O
P

MIR

DOOR MIRROR SYSTEM

< WIRING DIAGRAM >

[WITH ADP]

DOOR MIRROR (WITH AUTOMATIC DRIVE POSITIONER)

Connector No.	D3
Connector Name	DOOR MIRROR (PASSENGER SIDE)
Connector Type	TH24MM-NH



12	11	10	7	6	5	4	1	13
24	23	22	21	20	19	18	17	

Connector No.	D21
Connector Name	WIRE TO WIRE
Connector Type	TH40FW-CS15



15	14	13	12	11	10	9	8	7	6	5	4	3	2	1	
16	15	14	13	12	11	10	9	8	7	6	5	4	3	2	1



Connector No.	D41
Connector Name	WIRE TO WIRE
Connector Type	TH40FW-CS15



15	14	13	12	11	10	9	8	7	6	5	4	3	2	1	
16	15	14	13	12	11	10	9	8	7	6	5	4	3	2	1

Terminal No.	Color	Wire	Signal Name [Specification]
7	W		
8	P		- [Without passenger power window anti-pinch system]
8	V		- [With front power window anti-pinch system]
9	BR		- [Without passenger power window anti-pinch system]
9	L		- [With front power window anti-pinch system]
10	LG		
11	LG		
14	B		
15	W		
18	P		
17	Y		
18	R		
19	W		
21	R		
22	B		
23	W		
24	SHIELD		
25	G		
26	L		
38	LG		
39	LG		
39	L		
39	O		
40	B		
41	W		
42	B		
43	P		
45	G		

27	SB		
28	G		
29	V		
30	W		
31	O		
32	LG		
33	V		
34	BR		
35	P		
36	SB		
37	GR		
38	L		
39	V		
40	BR		
41	P		
42	V		
43	V		
44	B		
45	B		
45	P		
46	GR		
46	W		
47	P		
48	B		
49	G		
49	SB		
50	W		
51	R		
52	SHIELD		
54	G		
55	R		

Connector No.	D14
Connector Name	DOOR MIRROR REMOTE CONTROL SWITCH
Connector Type	TX10E8R



8	9	10	11	12	13	15	7
---	---	----	----	----	----	----	---

Terminal No.	Color	Wire	Signal Name [Specification]
4	LG		
7	B		
8	B		
9	BR		

Connector No.	D43
Connector Name	DOOR MIRROR (DRIVER SIDE)
Connector Type	TH24MM-NH



12	11	10	7	6	5	4	1	13
24	23	22	21	20	19	18	17	

JRLWC7425GB

DOOR MIRROR SYSTEM

< WIRING DIAGRAM >

[WITH ADP]

DOOR MIRROR (WITH AUTOMATIC DRIVE POSITIONER)

Terminal No.	Color Of Wire	Signal Name [Specification]
33	W	
34	BL	
35	W	
36	V	
37	P	
38	L	
39	LG	
40	O	
41	GR	
42	SB	
43	Y	
44	BR	
45	B	
46	SHIELD	
47	L	
48	BR	
49	B	
50	V	
51	G	
52	GR	
53	L	

Connector No.	E105
Connector Name	WIRE TO WIRE
Connector Type	1H170MW-CS10-M3



Terminal No.	Color Of Wire	Signal Name [Specification]
1	SHIELD	
2	W	
3	B	
4	R	
6	LG	
7	R	
8	GR	
9	SB	
10	BR	
11	P	
12	O	
13	W	
14	L	
15	P	
31	GR	
32	R	

Terminal No.	Color Of Wire	Signal Name [Specification]
33	W	
34	BL	
35	W	
36	V	
37	P	
38	L	
39	LG	
40	O	
41	GR	
42	SB	
43	Y	
44	BR	
45	B	
46	SHIELD	
47	L	
48	BR	
49	B	
50	V	
51	G	
52	GR	
53	L	

Connector No.	F23
Connector Name	TCM (TRANSMISSION CONTROL MODULE)
Connector Type	RH40EB-R2Z-L-RH



Terminal No.	Color Of Wire	Signal Name [Specification]
1	P/B	TRANSMISSION RANGE SWITCH 2
2	P/B	TRANSMISSION RANGE SWITCH 1
3	G/O	TRANSMISSION RANGE SWITCH 4
4	GR	TRANSMISSION RANGE SWITCH 3 (MONITOR)
5	B	GROUND
7	W	SENSOR GROUND
8	G/W	ROM ASSY (SEL 2)
9	L/R	ROM ASSY (SEL 1)
10	BR/R	ROM ASSY (SEL 3)
11	BR/R	TRANSMISSION RANGE SWITCH 1
13	V	CVT FLUID TEMPERATURE SENSOR
14	R/W	PRIMARY PRESSURE SENSOR
15	V/W	SECONDARY PRESSURE SENSOR
19	G/B	BACK-UP LAMP RELAY
20	R/B	STARTER RELAY
21	R/B	STARTER RELAY
26	L/O	SENSOR POWER
27	R/G	STEP MOTOR B
28	R	STEP MOTOR C
29	O/B	STEP MOTOR B
30	G/R	STEP MOTOR A
31	P	CAN-H
32	L	CAN-L
33	LG	PRIMARY SPEED SENSOR
34	LG/R	SECONDARY SPEED SENSOR
37	V/R	LOOK-UP SELECT SOLENOID VALVE
38	L/W	TORQUE CONVERTER GLITCH SOLENOID VALVE
39	W/B	SECONDARY PRESSURE SOLENOID VALVE
40	R/L	LINE PRESSURE SOLENOID VALVE
46	Y	IGNITION POWER SUPPLY
47	L/R	BATTERY POWER SUPPLY (MEMBER BUCK-UP)
48	Y	IGNITION POWER SUPPLY

Connector No.	M11
Connector Name	WIRE TO WIRE
Connector Type	1H170FW-CS10-M3

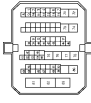

Terminal No.	Color Of Wire	Signal Name [Specification]
1	SHIELD	
2	W	
3	B	
4	R	
6	O	
7	G	
8	G	
9	B	
10	R	
11	W	
12	LG	
13	Y	
14	L	
15	P	
31	R	
32	V	
37	BR	
38	BR	
39	Y	
40	P	
41	L	
42	G	
43	W	
45	LG	
46	V	
47	LG	
49	G	
51	SB	
52	BR	
54	R	
55	L	
56	SHIELD	
61	BR	
62	LG	

A
B
C
D
E
F
G
H
I
J
K
L
M
N
O
P

MIR

DOOR MIRROR SYSTEM

< WIRING DIAGRAM >

[WITH ADP]

DOOR MIRROR (WITH AUTOMATIC DRIVE POSITIONER)

65	W/V	-	-
66	W/R	-	-
67	C	-	-
68	P	-	-
69	SB	-	-
70	Y	-	-
71	R	-	-
72	L	-	-
73	R	-	-
74	Y	-	-
75	G	-	-
76	V	-	-
77	P	-	-
78	V	-	-
79	W	-	-
80	W	-	-
81	W	-	-
82	L	-	-
83	R	-	-

Connector No.	M18
Connector Name	WIRE TO WIFE
Connector Type	TH40MM-CS15

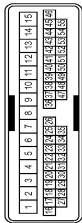

Terminal No.	Color Of Wire	Signal Name [Specification]
1	B/W	-
2	R	-
3	W	-
4	Y	-
5	SB	-
6	W	-
7	LG	-
8	BR	-
9	L	-
10	P	-
11	G	-
12	G	-
13	G	-
14	BR	- [With BOSE system]
15	R	- [Without BOSE system]

Connector No.	M20
Connector Name	WIRE TO WIFE
Connector Type	TH40MM-CS15

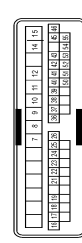

Terminal No.	Color Of Wire	Signal Name [Specification]
1	B/W	-
2	P	- [Without passenger power window anti-pinch system]
3	P	- [With front power window anti-pinch system]
4	BR	- [Without passenger power window anti-pinch system]
5	GR	- [With front power window anti-pinch system]
6	LG	-
7	SB	-
8	B	-
9	W	-
10	BR	-
11	P	-
12	R	-
13	Y	-
14	B	-
15	W	-
16	BR	-
17	P	-
18	R	-
19	Y	-
20	B	-
21	W	-
22	B	-
23	W	-
24	SHIELD	-
25	W/L	-
26	W/R	-
27	LG	-
28	P	-
29	P	-
30	G	-
31	G	-
32	G	-
33	Y	-
34	R/W	-
35	GR	-
36	LG	-
37	W	-
38	P	-
39	V	-
40	BR	-
41	P	-
42	V	-
43	SB	-
44	W	-
45	W/L	- [With automatic drive positioner]
46	Y	- [Without automatic drive positioner]
47	GR/V	- [With automatic drive positioner]
48	W	- [Without automatic drive positioner]
49	B/P	-
50	R/W	- [With automatic drive positioner]
51	V	- [Without automatic drive positioner]
52	LG	-
53	SHIELD	-
54	L/R	-
55	L/G	-

Connector No.	M48
Connector Name	CIRCUIT BREAKER
Connector Type	M02FW-P-LC



Terminal No.	Color Of Wire	Signal Name [Specification]
1	L	-
2	R	-

Connector No.	M75
Connector Name	AUTOMATIC DRIVE POSITIONER CONTROL UNIT
Connector Type	TH24FW-NH

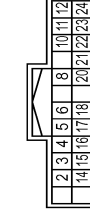

Terminal No.	Color Of Wire	Signal Name [Specification]
2	Y	SELECT RH
3	V	UPWARD
4	LG	LEFTWARD
5	R	MIR SENS UP DOWN (RH)
6	V	MIR SENS UP DOWN (LH)
8	GR	RC TX
10	BR	MIR MTR UP (RH)
11	W	MIR MTR UP (LH)
12	Y	MIR MTR DOWN (RH)
13	Y	MIR MTR DOWN (LH)
14	GR	SELECT LH
15	O	DOWNWARD
16	W	RIGHTWARD
17	BR	MIR SENS LEFT & RIGHT (RH)
18	SB	MIR SENS LEFT & RIGHT (LH)
20	P	SENS ON/OFF

DOOR MIRROR SYSTEM

[WITH ADP]

< WIRING DIAGRAM >

DOOR MIRROR (WITH AUTOMATIC DRIVE POSITIONER)

21	Y	SEIS POWER
22	G	MIR MTR (RH)
23	W	MIR MTR (LH)
24	W	MIR MTR LEFT (LH)

Connector No.	M17
Connector Name	WIRE TO WIRE
Connector Type	TH489FW-CS19



Terminal No.	Color Of Wire	Signal Name [Specification]
10	GR	-
12	V	-
13	W	-
15	Y	-
29	L	-
30	P	-
31	BR	-
37	SHIELD	-
38	B	- [Without automatic drive positioner]
39	Y	- [Without automatic drive positioner]
40	R	- [Without automatic drive positioner]
51	V	-
52	B	-
53	O	-
54	P	-
55	L	-
57	Y	-
58	L	-
59	O	-
60	G	-
61	LG	-
62	SB	-
64	R	-
65	G	-
66	SHIELD	-
67	W/L	-
68	GR/V	-

69	SHIELD	-
71	W/L	-
72	GR	-
74	GR	-
75	G	-
77	O	-
78	LG	-
79	R	-
80	G	-
81	L	-
82	W	-
87	V	-
88	R	-
89	B	-
90	Y	- [Without automatic drive positioner]
91	SB	- [Without automatic drive positioner]
92	P	-

Connector No.	M104
Connector Name	AUTOMATIC DRIVE POSITIONER CONTROL UNIT
Connector Type	HS09FW-CS



Terminal No.	Color Of Wire	Signal Name [Specification]
25	R	BAT
30	B/W	GROUND

Connector No.	M121
Connector Name	BOM (BODY CONTROL MODULE)
Connector Type	TH489EB-NH

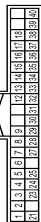

Terminal No.	Color Of Wire	Signal Name [Specification]
1	W	REAR WINDOW DEF RELAY CONT
2	Y	COMBI SW INPUT 1
3	LG	COMBI SW INPUT 2
4	O	COMBI SW INPUT 3
5	G	COMBI SW INPUT 2
6	L	COMBI SW INPUT 1
7	W	KEY CYL UNLOCK SW
8	GR	PW SW COMM [With automatic sliding door]
8	Y	KEY CYL LOCK SW [Without automatic sliding door]
9	V	STOP LAMP SW 1
12	GR	DOOR LK & UNLK SW UNLOCK
13	BR	DOOR LK & UNLK SW UNLOCK
14	L	OPTICAL SENS
15	W	REAR WINDOW DEF SW
16	Y	SEIS POWER SW
18	R	RECEIVER COMM
19	P	MATS ANT AMP
21	R	SECURITY END CONT
23	V	SECURITY END CONT
24	B	DORNGLE LINK
25	W	MATS ANT AMP
27	O	A/C ON
28	BR	BLOWER FAN ON
29	P	HAZARD SW
30	L	BK DOOR OPNR SW
31	O	DR DOOR UNLK SENS
32	Y	COMBI SW OUTPUT 3
33	W	COMBI SW OUTPUT 4
34	GR	COMBI SW OUTPUT 3
35	SB	COMBI SW OUTPUT 2
36	R	COMBI SW OUTPUT 1
37	G	BETFEAT SW
38	SB	RECEIVER COMM
39	L	CAN-H
40	P	CAN-L

JRLWC7428GB

A
B
C
D
E
F
G
H
I
J
K
M
N
O
P

MIR

AUTO ANTI-DAZZLING INSIDE MIRROR SYSTEM

< WIRING DIAGRAM >

[WITH ADP]

AUTO ANTI-DAZZLING INSIDE MIRROR SYSTEM

Wiring Diagram

INFOID:000000009652710

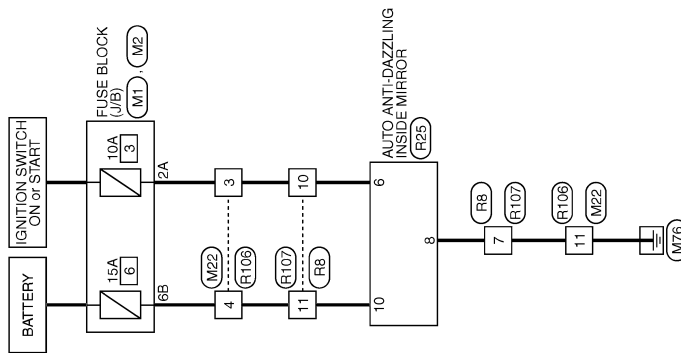

INSIDE MIRROR

2012/07/19

JRLWC2666GB

AUTO ANTI-DAZZLING INSIDE MIRROR SYSTEM

[WITH ADP]

< WIRING DIAGRAM >

INSIDE MIRROR

Connector No.	M1
Connector Name	FUSE BLOCK (J/B)
Connector Type	NSJDFW-M2



Terminal No.	Color Of Wire	Signal Name [Specification]
1A	Y	--
2A	G	--
3A	L	--
4A	GR	--
5A	V	--
6A	R	--
7A	GR	--
8A	L	--

Connector No.	M2
Connector Name	FUSE BLOCK (J/B)
Connector Type	NSJDFW-CS

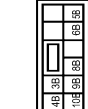

Terminal No.	Color Of Wire	Signal Name [Specification]
10B	R	--
3B	V	--
4B	W	--
5B	BR	--
8B	O	--
9B	GR	--

Connector No.	M22
Connector Name	WIRE TO WIRE
Connector Type	TH1BFW-NH



Terminal No.	Color Of Wire	Signal Name [Specification]
1	BR	--
2	GR	--
3	W	--
4	O	--
6	R	--
7	SR	--
8	GR	--
9	P	--
10	R	--
11	B/W	--
12	B	--
13	R	--
14	W/L	-- [Without MAV]
15	Y	-- [Without MAV]
16	SHIELD	-- [Without MAV]
17	W	-- [Without MAV]
18	W/R	-- [Without MAV]

Connector No.	F8
Connector Name	WIRE TO WIRE
Connector Type	TH1ZFW-NH



Terminal No.	Color Of Wire	Signal Name [Specification]
1	W/L	--
2	BR	--
3	BR/R	-- [With manual A/C]
4	V	-- [With manual A/C]
5	R	-- [With manual A/C]
6	O	-- [With manual A/C]
7	B	-- [With manual A/C]
8	O	--
9	P	--
10	V	--
11	BR	--

Connector No.	R25
Connector Name	AUTO ANTI-DAZZLING INSIDE MIRROR
Connector Type	TH1DFE-NH

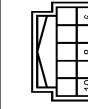

Terminal No.	Color Of Wire	Signal Name [Specification]
8	W	--
9	G	--
10	BR	--

Connector No.	R106
Connector Name	WIRE TO WIRE
Connector Type	TH1BMM-NH

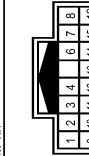

Terminal No.	Color Of Wire	Signal Name [Specification]
1	G	--
2	SB	--
3	P	--
4	LG	--
6	O	--
7	W	--
8	BR	--
9	L	--
10	LG	--
11	B	--
12	V	--
13	Y	--
14	SHIELD	--
15	BR	--

Connector No.	R107
Connector Name	WIRE TO WIRE
Connector Type	TH1ZMM-NH



Terminal No.	Color Of Wire	Signal Name [Specification]
1	P	--
2	SB	--
3	G	--
4	Y	--
7	B	--
8	R	--
9	L	--
10	P	--
11	LG	--

A
B
C
D
E
F
G
H
I
J
K
L
M
N
O
P

MIR

JRLWC7431GB

REVERSE INTERLOCK DOOR MIRROR DOES NOT OPERATE

< SYMPTOM DIAGNOSIS >

[WITH ADP]

SYMPTOM DIAGNOSIS

REVERSE INTERLOCK DOOR MIRROR DOES NOT OPERATE

Diagnosis Procedure

INFOID:000000009652711

1. CHECK DOOR MIRROR (MANUAL FUNCTION)

Check door mirror function with door mirror remote control switch.
Refer to [ADP-95, "Diagnosis Procedure"](#).

Is the inspection result normal?

- YES >> GO TO 2.
- NO >> Repair or replace the malfunctioning parts.

2. CHECK DTC

Check DTC for TCM.
Refer to [TM-48, "DTC Index"](#).

Is the inspection result normal?

- YES >> GO TO 3.
- NO >> Repair or replace the malfunctioning parts.

3. CONFIRM THE OPERATION

Confirm the operation again.

Is the result normal?

- YES >> Check intermittent incident. Refer to [GI-42, "Intermittent Incident"](#).
- NO >> GO TO 1.

SQUEAK AND RATTLE TROUBLE DIAGNOSES

< SYMPTOM DIAGNOSIS >

[WITH ADP]

SQUEAK AND RATTLE TROUBLE DIAGNOSES

Work Flow

INFOID:000000009652712

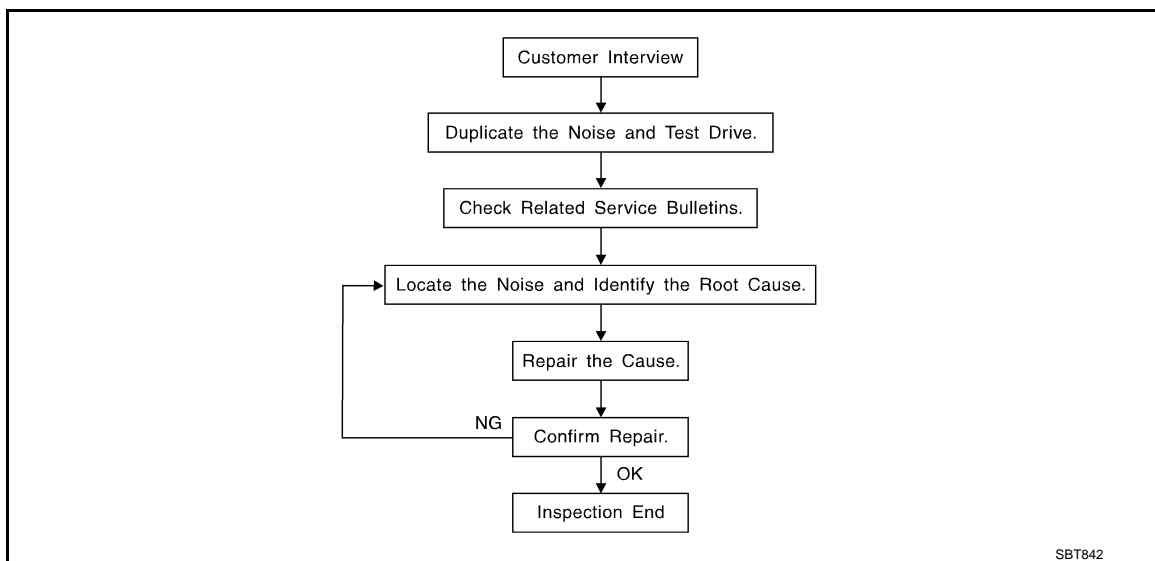

CUSTOMER INTERVIEW

Interview the customer if possible, to determine the conditions that exist when the noise occurs. Use the Diagnostic Worksheet during the interview to document the facts and conditions when the noise occurs and any of customer's comments; refer to [MIR-27, "Diagnostic Worksheet"](#). This information is necessary to duplicate the conditions that exist when the noise occurs.

- The customer may not be able to provide a detailed description or the location of the noise. Attempt to obtain all the facts and conditions that exist when the noise occurs (or does not occur).
- If there is more than one noise in the vehicle, perform a diagnosis and repair the noise that the customer is concerned about. This can be accomplished by performing a cruise test on the vehicle with the customer.
- After identifying the type of noise, isolate the noise in terms of its characteristics. The noise characteristics are provided so the customer, service adviser and technician are all speaking the same language when defining the noise.
- Squeak —(Like tennis shoes on a clean floor)
Squeak characteristics include the light contact/fast movement/brought on by road conditions/hard surfaces=higher pitch noise/softer surfaces=lower pitch noises/edge to surface=chirping
- Creak—(Like walking on an old wooden floor)
Creak characteristics include firm contact/slow movement/twisting with a rotational movement/pitch dependent on materials/often brought on by activity.
- Rattle—(Like shaking a baby rattle)
Rattle characteristics include the fast repeated contact/vibration or similar movement/loose parts/missing clip or fastener/incorrect clearance.
- Knock —(Like a knock on a door)
Knock characteristics include hollow sounding/sometimes repeating/often brought on by driver action.
- Tick—(Like a clock second hand)
Tick characteristics include gentle contacting of light materials/loose components/can be caused by driver action or road conditions.
- Thump—(Heavy, muffled knock noise)
Thump characteristics include softer knock/dead sound often brought on by activity.
- Buzz—(Like a bumblebee)
Buzz characteristics include high frequency rattle/firm contact.
- Often the degree of acceptable noise level will vary depending up on the person. A noise that you may judge as acceptable may be very irritating to the customer.
- Weather conditions, especially humidity and temperature, may have a great effect on noise level.

DUPLICATE THE NOISE AND TEST DRIVE

If possible, drive the vehicle with the customer until the noise is duplicated. Note any additional information on the Diagnostic Worksheet regarding the conditions or location of the noise. This information can be used to duplicate the same conditions when you confirm the repair.

SQUEAK AND RATTLE TROUBLE DIAGNOSES

[WITH ADP]

< SYMPTOM DIAGNOSIS >

If the noise can be duplicated easily during the test drive, to help identify the source of the noise, try to duplicate the noise with the vehicle stopped by doing one or all of the following:

- 1) Close a door.
 - 2) Tap or push/pull around the area where the noise appears to be coming from.
 - 3) Rev the engine.
 - 4) Use a floor jack to recreate vehicle "twist".
 - 5) At idle, apply engine load (electrical load, half-clutch on M/T models, drive position on A/T models).
 - 6) Raise the vehicle on a hoist and hit a tire with a rubber hammer.
- Drive the vehicle and attempt to duplicate the conditions the customer states exist when the noise occurs.
 - If it is difficult to duplicate the noise, drive the vehicle slowly on an undulating or rough road to stress the vehicle body.

CHECK RELATED SERVICE BULLETINS

After verifying the customer concern or symptom, check ASIST for Technical Service Bulletins (TSBs) related to that concern or symptom.

If a TSB relates to the symptom, follow the procedure to repair the noise.

LOCATE THE NOISE AND IDENTIFY THE ROOT CAUSE

1. Narrow down the noise to a general area. To help pinpoint the source of the noise, use a listening tool (Chassis Ear: J-39570, Engine Ear and mechanics stethoscope).
2. Narrow down the noise to a more specific area and identify the cause of the noise by:
 - removing the components in the area that you suspect the noise is coming from.
Do not use too much force when removing clips and fasteners, otherwise clips and fastener can be broken or lost during the repair, resulting in the creation of new noise.
 - tapping or pushing/pulling the component that you suspect is causing the noise.
Do not tap or push/pull the component with excessive force, otherwise the noise will be eliminated only temporarily.
 - feeling for a vibration with your hand by touching the component(s) that you suspect is (are) causing the noise.
 - placing a piece of paper between components that you suspect are causing the noise.
 - looking for loose components and contact marks.
Refer to [MIR-25. "Inspection Procedure"](#).

REPAIR THE CAUSE

- If the cause is a loose component, tighten the component securely.
- If the cause is insufficient clearance between components:
 - separate components by repositioning or loosening and retightening the component, if possible.
 - insulate components with a suitable insulator such as urethane pads, foam blocks, felt cloth tape or urethane tape. A Nissan Squeak and Rattle Kit (J-50397) is available through your authorized Nissan Parts Department.

CAUTION:

Do not use excessive force as many components are constructed of plastic and may be damaged.

NOTE:

Always check with the Parts Department for the latest parts information.

The following materials are contained in the Nissan Squeak and Rattle Kit (J-50397). Each item can be ordered separately as needed.

URETHANE PADS [1.5 mm (0.059 in) thick]

Insulates connectors, harness, etc.

76268-9E005: 100 × 135 mm (3.94 × 5.31 in)/76884-71L01: 60 × 85 mm (2.36 × 3.35 in)/76884-

71L02: 15 × 25 mm (0.59 × 0.98 in)

INSULATOR (Foam blocks)

Insulates components from contact. Can be used to fill space behind a panel.

73982-9E000: 45 mm (1.77 in) thick, 50 × 50 mm (1.97 × 1.97 in)/73982-

50Y00: 10 mm (0.39 in) thick, 50 × 50 mm (1.97 × 1.97 in)

INSULATOR (Light foam block)

80845-71L00: 30 mm (1.18 in) thick, 30 × 50 mm (1.18 × 1.97in)

FELT CLOTHTAPE

Used to insulate where movement does not occur. Ideal for instrument panel applications.

68370-4B000: 15 × 25 mm (0.59 × 0.98 in) pad/68239-13E00: 5 mm (0.20 in) wide tape roll

The following materials, not found in the kit, can also be used to repair squeaks and rattles.

UHMW (TEFLON) TAPE

SQUEAK AND RATTLE TROUBLE DIAGNOSES

[WITH ADP]

< SYMPTOM DIAGNOSIS >

Insulates where slight movement is present. Ideal for instrument panel applications.

SILICONE GREASE

Used in place of UHMW tape that will be visible or not fit. Will only last a few months.

SILICONE SPRAY

Use when grease cannot be applied.

DUCT TAPE

Use to eliminate movement.

CONFIRM THE REPAIR

Confirm that the cause of a noise is repaired by test driving the vehicle. Operate the vehicle under the same conditions as when the noise originally occurred. Refer to the notes on the Diagnostic Worksheet.

Inspection Procedure

INFOID:000000009652713

Refer to Table of Contents for specific component removal and installation information.

INSTRUMENT PANEL

Most incidents are caused by contact and movement between:

1. The cluster lid A and instrument panel
2. Acrylic lens and combination meter housing
3. Instrument panel to front pillar garnish
4. Instrument panel to windshield
5. Instrument panel mounting pins
6. Wiring harnesses behind the combination meter
7. A/C defroster duct and duct joint

These incidents can usually be located by tapping or moving the components to duplicate the noise or by pressing on the components while driving to stop the noise. Most of these incidents can be repaired by applying felt cloth tape or silicon spray (in hard to reach areas). Urethane pads can be used to insulate wiring harness.

CAUTION:

Do not use silicone spray to isolate a squeak or rattle. If you saturate the area with silicone, you will not be able to recheck the repair.

CENTER CONSOLE

Components to pay attention to include:

1. Shifter assembly cover to finisher
2. A/C control unit and cluster lid C
3. Wiring harnesses behind audio and A/C control unit

The instrument panel repair and isolation procedures also apply to the center console.

DOORS

Pay attention to the:

1. Finisher and inner panel making a slapping noise
2. Inside handle escutcheon to door finisher
3. Wiring harnesses tapping
4. Door striker out of alignment causing a popping noise on start and stops

Tapping or moving the components or pressing on them while driving to duplicate the conditions can isolate many of these incidents. You can usually insulate the areas with felt cloth tape or insulator foam blocks from the Nissan Squeak and Rattle Kit (J-50397) to repair the noise.

TRUNK

Trunk noises are often caused by a loose jack or loose items put into the trunk by the owner.

In addition look for:

1. Trunk lid dumpers out of adjustment
2. Trunk lid striker out of adjustment
3. The trunk lid torsion bars knocking together
4. A loose license plate or bracket

A

B

C

D

E

F

G

H

I

J

K

MIR

M

N

O

P

SQUEAK AND RATTLE TROUBLE DIAGNOSES

[WITH ADP]

< SYMPTOM DIAGNOSIS >

Most of these incidents can be repaired by adjusting, securing or insulating the item(s) or component(s) causing the noise.

SUNROOF/HEADLINING

Noises in the sunroof/headlining area can often be traced to one of the following:

1. Sunroof lid, rail, linkage or seals making a rattle or light knocking noise
2. Sunvisor shaft shaking in the holder
3. Front or rear windshield touching headlining and squeaking

Again, pressing on the components to stop the noise while duplicating the conditions can isolate most of these incidents. Repairs usually consist of insulating with felt cloth tape.

SEATS

When isolating seat noise it's important to note the position the seat is in and the load placed on the seat when the noise is present. These conditions should be duplicated when verifying and isolating the cause of the noise.

Cause of seat noise include:

1. Headrest rods and holder
2. A squeak between the seat pad cushion and frame
3. The rear seatback lock and bracket

These noises can be isolated by moving or pressing on the suspected components while duplicating the conditions under which the noise occurs. Most of these incidents can be repaired by repositioning the component or applying urethane tape to the contact area.

UNDERHOOD

Some interior noise may be caused by components under the hood or on the engine wall. The noise is then transmitted into the passenger compartment.

Causes of transmitted underhood noise include:

1. Any component mounted to the engine wall
2. Components that pass through the engine wall
3. Engine wall mounts and connectors
4. Loose radiator mounting pins
5. Hood bumpers out of adjustment
6. Hood striker out of adjustment

These noises can be difficult to isolate since they cannot be reached from the interior of the vehicle. The best method is to secure, move or insulate one component at a time and test drive the vehicle. Also, engine RPM or load can be changed to isolate the noise. Repairs can usually be made by moving, adjusting, securing, or insulating the component causing the noise.

SQUEAK AND RATTLE TROUBLE DIAGNOSES

< SYMPTOM DIAGNOSIS >

[WITH ADP]

Diagnostic Worksheet

INFOID:000000009652714



SQUEAK & RATTLE DIAGNOSTIC WORKSHEET

Dear Infiniti Customer:

We are concerned about your satisfaction with your Infiniti vehicle. Repairing a squeak or rattle sometimes can be very difficult. To help us fix your Infiniti right the first time, please take a moment to note the area of the vehicle where the squeak or rattle occurs and under what conditions. You may be asked to take a test drive with a service consultant or technician to ensure we confirm the noise you are hearing.

I. WHERE DOES THE NOISE COME FROM? (circle the area of the vehicle)

The illustrations are for reference only, and may not reflect the actual configuration of your vehicle.

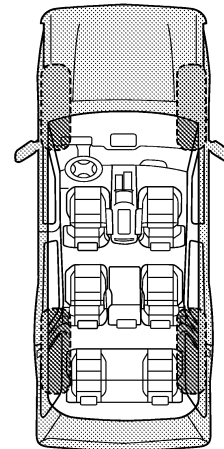
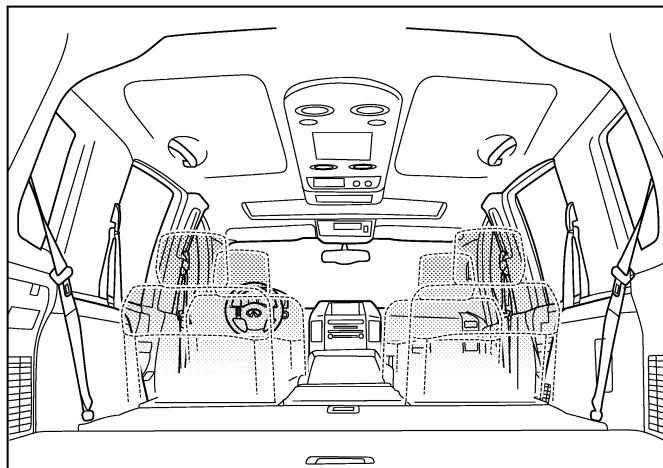
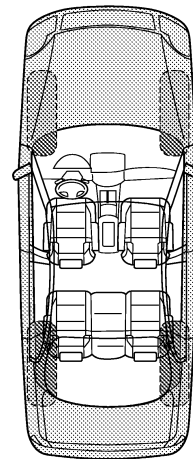
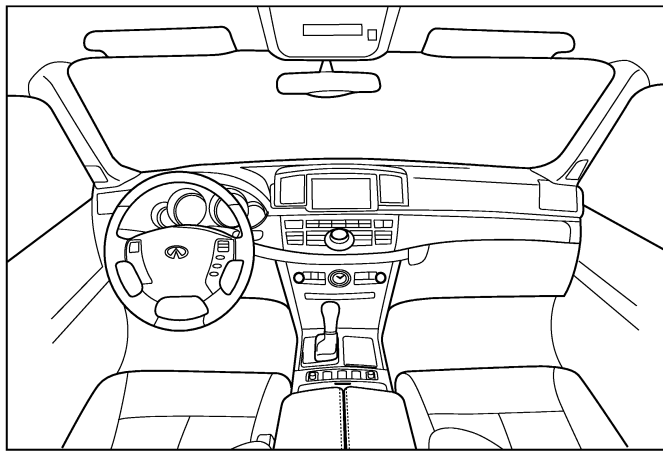

Continue to page 2 of the worksheet and briefly describe the location of the noise or rattle. In addition, please indicate the conditions which are present when the noise occurs.

PIIB8741E

A
B
C
D
E
F
G
H
I
J
K
M
N
O
P

MIR

SQUEAK AND RATTLE TROUBLE DIAGNOSES

< SYMPTOM DIAGNOSIS >

[WITH ADP]

SQUEAK & RATTLE DIAGNOSTIC WORKSHEET - page 2

Briefly describe the location where the noise occurs:

II. WHEN DOES IT OCCUR? (please check the boxes that apply)

- | | |
|---|--|
| <input type="checkbox"/> anytime | <input type="checkbox"/> after sitting out in the rain |
| <input type="checkbox"/> 1st time in the morning | <input type="checkbox"/> when it is raining or wet |
| <input type="checkbox"/> only when it is cold outside | <input type="checkbox"/> dry or dusty conditions |
| <input type="checkbox"/> only when it is hot outside | <input type="checkbox"/> other: |

III. WHEN DRIVING:

- through driveways
- over rough roads
- over speed bumps
- only about ____ mph
- on acceleration
- coming to a stop
- on turns: left, right or either (circle)
- with passengers or cargo
- other: _____
- after driving ____ miles or ____ minutes

IV. WHAT TYPE OF NOISE

- squeak (like tennis shoes on a clean floor)
- creak (like walking on an old wooden floor)
- rattle (like shaking a baby rattle)
- knock (like a knock at the door)
- tick (like a clock second hand)
- thump (heavy, muffled knock noise)
- buzz (like a bumble bee)

TO BE COMPLETED BY DEALERSHIP PERSONNEL

Test Drive Notes:

	YES	NO	Initials of person performing
Vehicle test driven with customer	<input type="checkbox"/>	<input type="checkbox"/>	_____
- Noise verified on test drive	<input type="checkbox"/>	<input type="checkbox"/>	_____
- Noise source located and repaired	<input type="checkbox"/>	<input type="checkbox"/>	_____
- Follow up test drive performed to confirm repair	<input type="checkbox"/>	<input type="checkbox"/>	_____

VIN: _____ Customer Name: _____
W.O.# _____ Date: _____

This form must be attached to Work Order

PIIB8742E

INSIDE MIRROR

< REMOVAL AND INSTALLATION >

[WITH ADP]

REMOVAL AND INSTALLATION

INSIDE MIRROR

Exploded View

INFOID:000000009652715

Manual anti-dazzling type

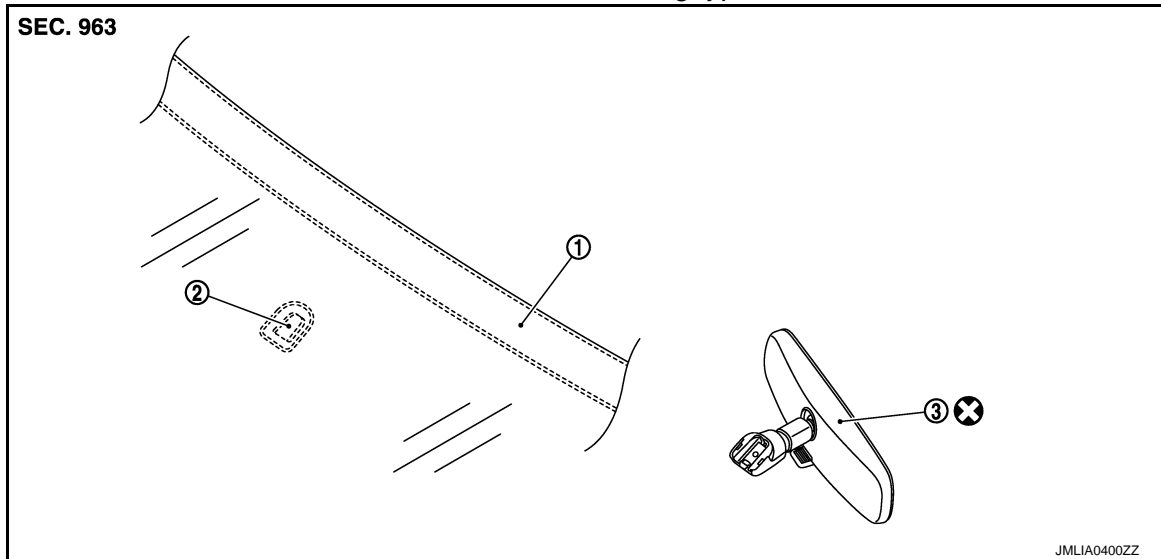

1. Windshield glass 2. Inside mirror base 3. Inside mirror assembly

⊗ : Always replace after every disassembly.

Auto anti-dazzling type

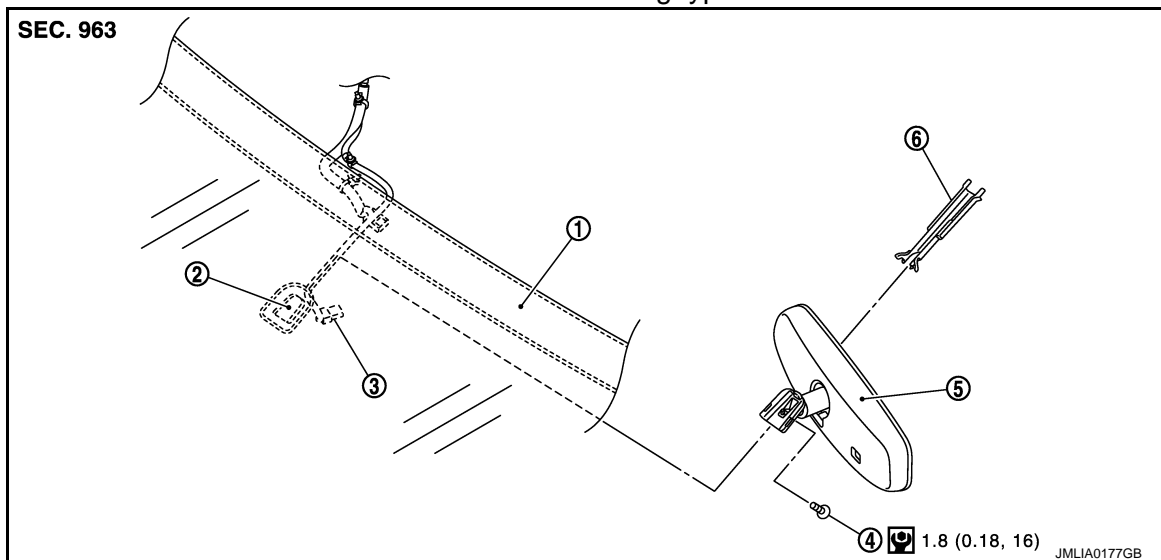

1. Windshield glass 2. Inside mirror base 3. Harness connector
4. TORX bolt 5. Inside mirror assembly 6. Inside mirror cover

⊙ : N·m (kg·m, in·lb)

Removal and Installation

INFOID:000000009652716

REMOVAL

Manual anti-dazzling type

A
B
C
D
E
F
G
H
I
J
K
M
N
O
P

MIR

INSIDE MIRROR

< REMOVAL AND INSTALLATION >

[WITH ADP]

1. Insert a flat-bladed screwdriver (A) under the inside mirror (1).
2. Slide the inside mirror to the upper side while pushing the pawl downward.

⊗ : Always replace after every disassembly

CAUTION:

- Never reuse the inside mirror disassembled from inside mirror base.
- Never use excessive force to remove the inside mirror because it is inserted tightly into the mirror base.
- Wrap the flat-bladed screwdriver with a shop cloth to avoid damage on the windshield glass.

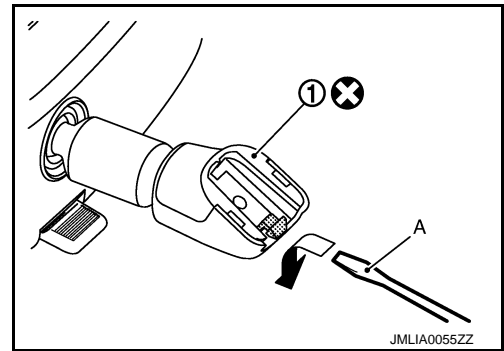

Auto anti-dazzling type

1. Remove inside mirror cover.
2. Disconnect harness connector from inside mirror.
3. Loosen TORX bolt and slide inside mirror upward to remove.

INSTALLATION

Install in the reverse order of removal.

CAUTION:

When inserting the inside mirror into the mirror base, be sure to push the pawl until it get connected to the mirror base (manual anti-dazzling type only).

DOOR MIRROR

< REMOVAL AND INSTALLATION >

[WITH ADP]

DOOR MIRROR

Exploded View

INFOID:000000009652717

Models with around view camera

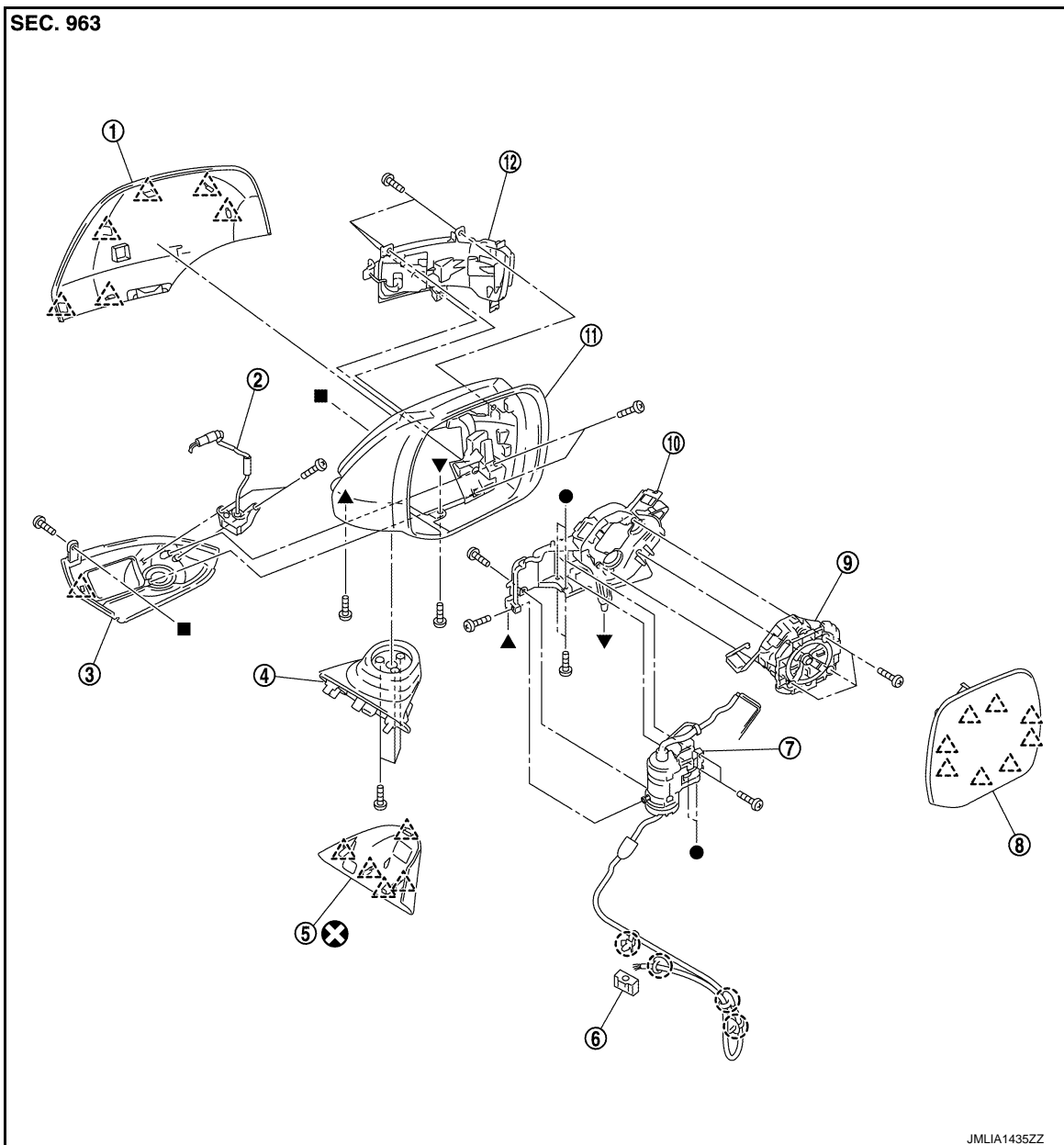

- | | | |
|----------------------|-----------------------------|--------------------------------|
| 1. Door mirror cover | 2. Around view camera | 3. Around view camera finisher |
| 4. Door mirror base | 5. Door mirror corner cover | 6. Connector |
| 7. Power fold unit | 8. Glass mirror | 9. Actuator |
| 10. Actuator bracket | 11. Door mirror housing | 12. Side turn signal lamp |

○ : Clip

△ : Pawl

⊗ : Always replace after every disassembly.

●, ▲, ■, ▼ : Indicates that the part is connected at points with same symbol in actual vehicle.

A
B
C
D
E
F
G
H
I
J
K
L
M
N
O
P

MIR

DOOR MIRROR

< REMOVAL AND INSTALLATION >

[WITH ADP]

Models with side turn signal lamp

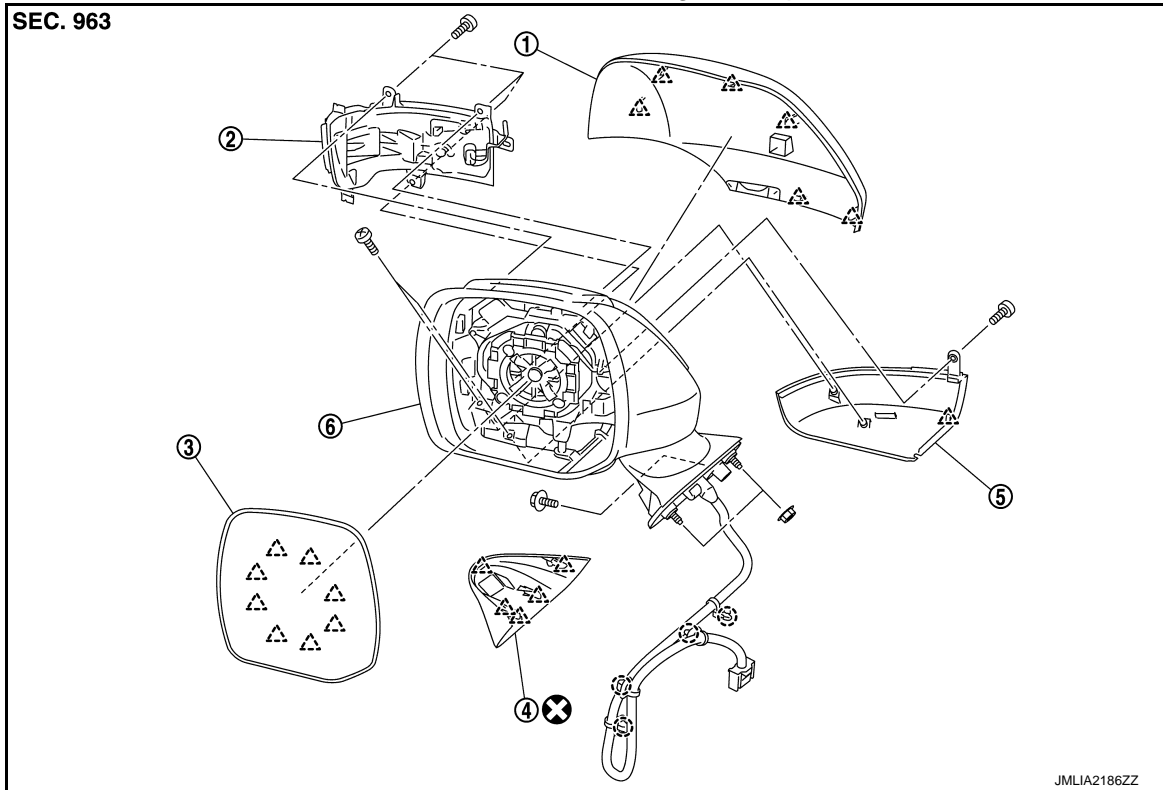

- | | | |
|-----------------------------|----------------------------|-----------------|
| 1. Door mirror cover | 2. Side turn signal lamp | 3. Glass mirror |
| 4. Door mirror corner cover | 5. Door mirror under cover | 6. Door mirror |

○ : Clip

△ : Pawl

⊗ : Always replace after every disassembly.

DOOR MIRROR

< REMOVAL AND INSTALLATION >

[WITH ADP]

Models without side turn signal lamp

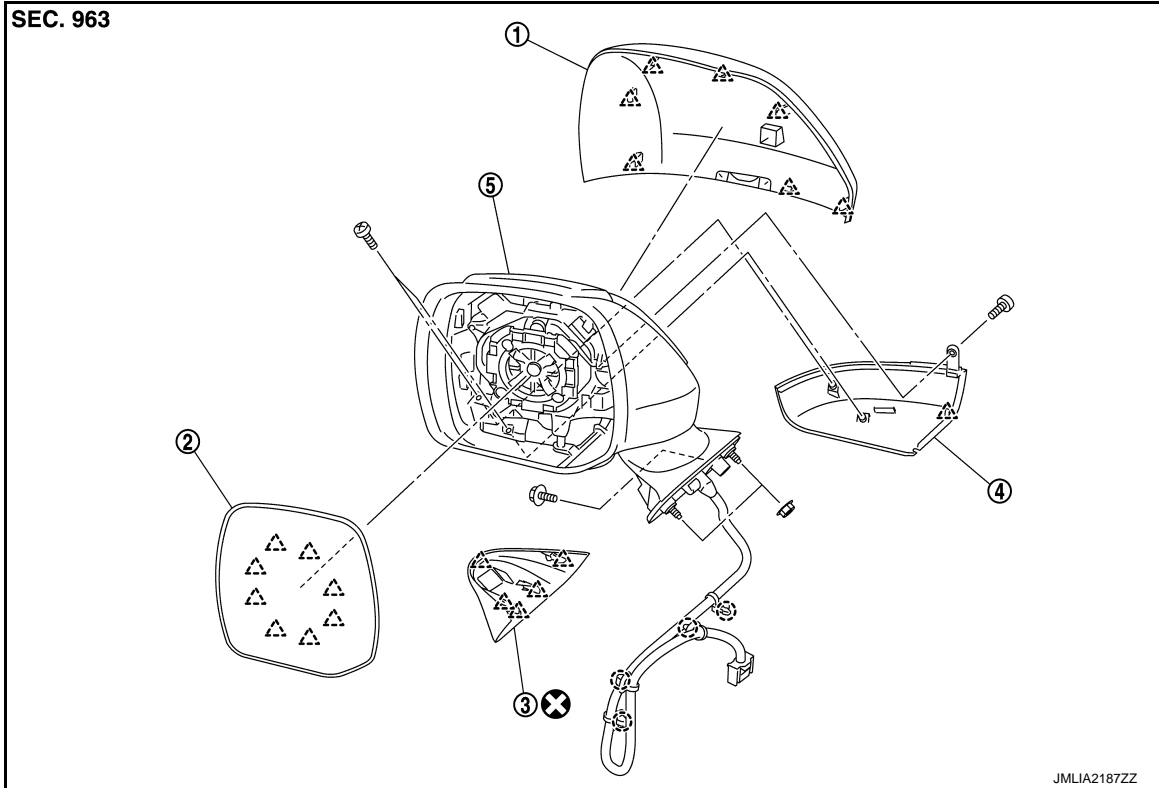

- | | | |
|----------------------------|-----------------|-----------------------------|
| 1. Door mirror cover | 2. Glass mirror | 3. Door mirror corner cover |
| 4. Door mirror under cover | 5. Door mirror | |

○ : Clip

△ : Pawl

⊗ : Always replace after every disassembly.

DOOR MIRROR ASSEMBLY

DOOR MIRROR ASSEMBLY : Removal and Installation

INFOID:000000009652718

CAUTION:

- When removing, always use a remover tool that is made of plastic.
- Be careful not to scratch or damage door mirror body when removing.
- Always replace door mirror corner cover after every disassembly.

REMOVAL

1. Remove front door finisher. Refer to [INT-14, "Removal and Installation"](#).
2. Remove front door module assembly mounting bolts, pull out the front door module assembly to make space in order to disengage the harness connector.

A
B
C
D
E
F
G
H
I
J
K
M
N
O
P

MIR

DOOR MIRROR

< REMOVAL AND INSTALLATION >

[WITH ADP]

3. Remove harness connector (A).
4. Remove front door speaker and then, from the hole of front door speaker disconnect the harness connectors.

 : Clip

5. Peel off front door weather-strip (1), and then remove door mirror mounting nuts (B).

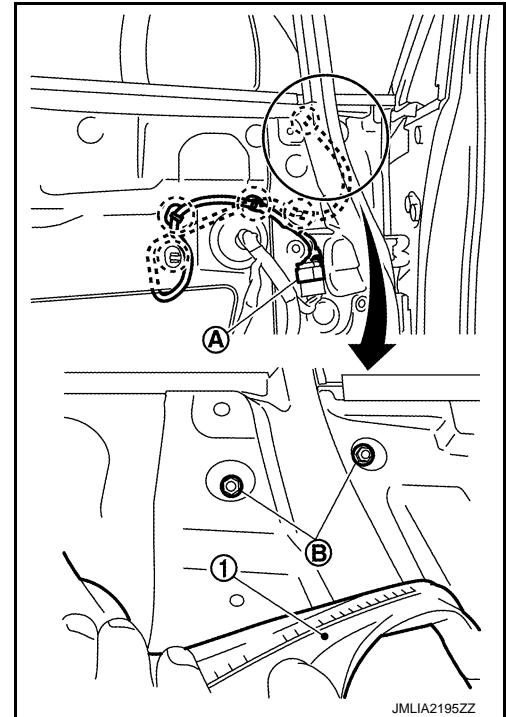

6. Remove door mirror corner cover.
 - a. Disengage the door mirror corner cover fixing pawls with remover tool (A). (front door side)

 : Pawl

 : Vehicle front

CAUTION:

Apply protective tape (B) on the part to protect it from damage.

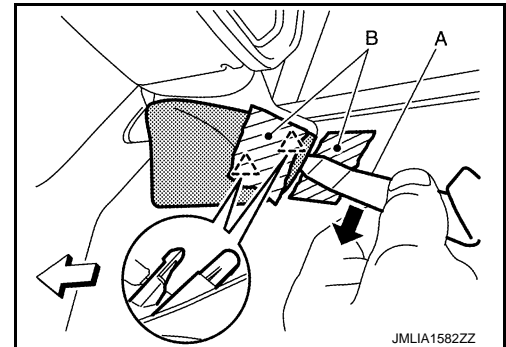

- b. Disengage the door mirror corner cover fixing pawls with remover tool (A). (front fender side)

 : Pawl

 : Vehicle front

CAUTION:

Apply protective tape (B) on the part to protect it from damage.

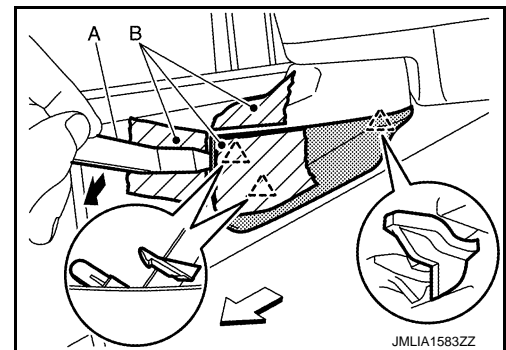

7. Remove door mirror mounting bolt.
8. Remove door mirror assembly from door panel.

INSTALLATION

1. Insert door mirror harness connector through the door outer panel hole.
2. Install door mirror assembly into the door panel and tighten the mounting bolt and nuts.
3. Install the door mirror harness fixing clips to the door panel from the hole of door speaker.
4. Install front door finisher.

DOOR MIRROR

< REMOVAL AND INSTALLATION >

[WITH ADP]

DOOR MIRROR ASSEMBLY : Disassembly and Assembly

INFOID:000000009652719

CAUTION:

When removing, always use a remover tool that is made of plastic.

DISASSEMBLY

1. Remove door mirror assembly from the door panel. Refer to [MIR-33, "DOOR MIRROR ASSEMBLY : Removal and Installation"](#).
2. Remove glass mirror. Refer to [MIR-37, "GLASS MIRROR : Removal and Installation"](#).
3. Remove door mirror cover. Refer to [MIR-38, "DOOR MIRROR COVER : Removal and Installation"](#).

4. Remove door mirror actuator (1).

- a. Remove the mounting screws (A).
- b. Disconnect the harness connectors behind the actuator.
- c. Disconnect auto driving positioning harness connector (B).(if equipped)

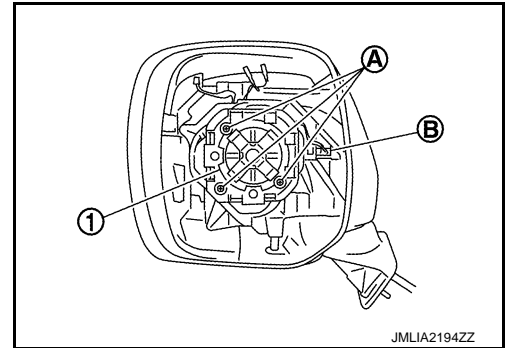

5. Remove around view camera finisher assembly (1). (with around view camera)

1. Remove around view camera finisher mounting screw (A).

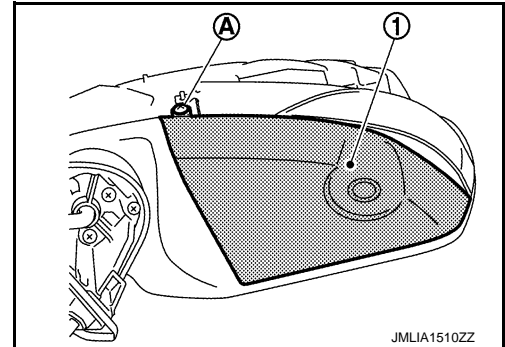

2. Disconnect harness connector (B) and remove mounting screws (C).
3. Disengage around view camera finisher assembly (1) fixing pawls and remove it from door mirror housing.

 : Pawl

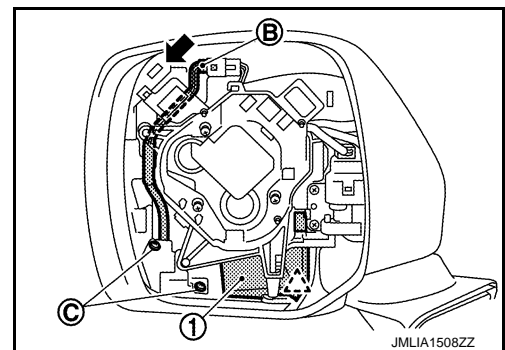

6. Remove around view camera mounting screws and then remove it from around view camera finisher. Refer to [AV-631, "Removal and Installation"](#).
7. Remove door mirror under cover (1). (with side turn signal lamp)

A
B
C
D
E
F
G
H
I
J
K
M
N
O
P

MIR

DOOR MIRROR

< REMOVAL AND INSTALLATION >

[WITH ADP]

- a. Remove door mirror under cover mounting screw (A).

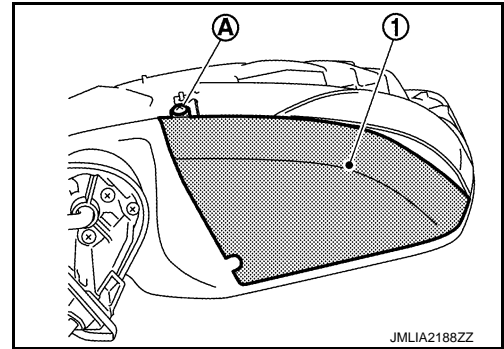

- b. Remove door mirror under cover mounting screws (A) and disengage the fixing pawl.

 : Pawl

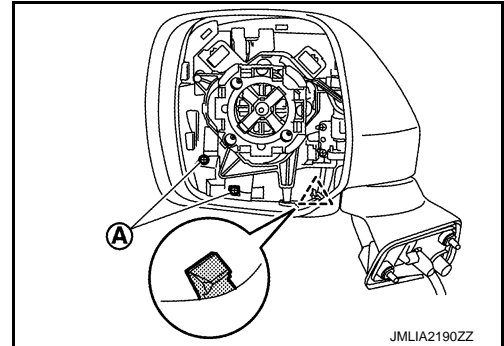

- c. Remove door mirror side turn signal lamp mounting screws (A) and remove side turn signal lamp.

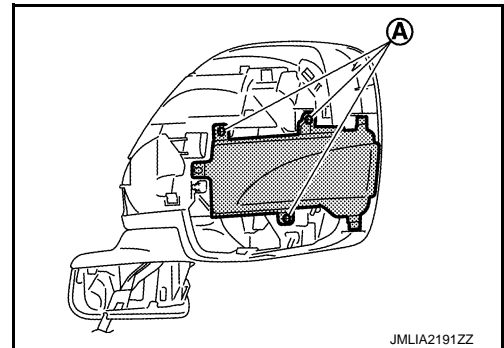

8. Remove door mirror under cover (1). (without side turn signal lamp)

- a. Remove door mirror under cover mounting screw (A).

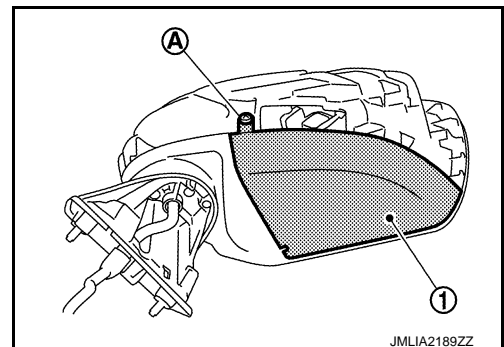

DOOR MIRROR

< REMOVAL AND INSTALLATION >

[WITH ADP]

- b. Remove door mirror under cover mounting screws (A) and disengage the fixing pawl.

 : Pawl

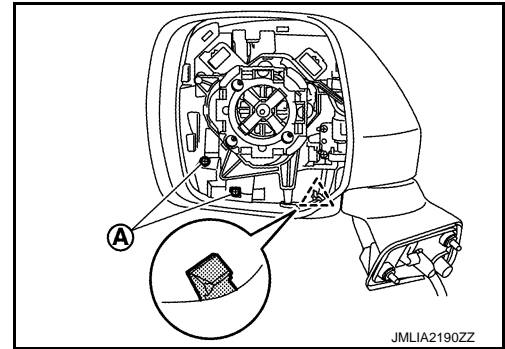

9. Remove the mounting bolts (A) and remove door mirror base from door mirror housing.

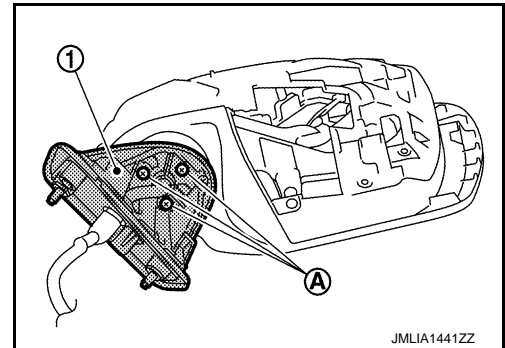

10. Remove power fold unit.

- a. Remove power fold unit assembly fixing screws (A).
b. Remove power fold unit assembly from door mirror housing according to the numerical order shown in the figure below.

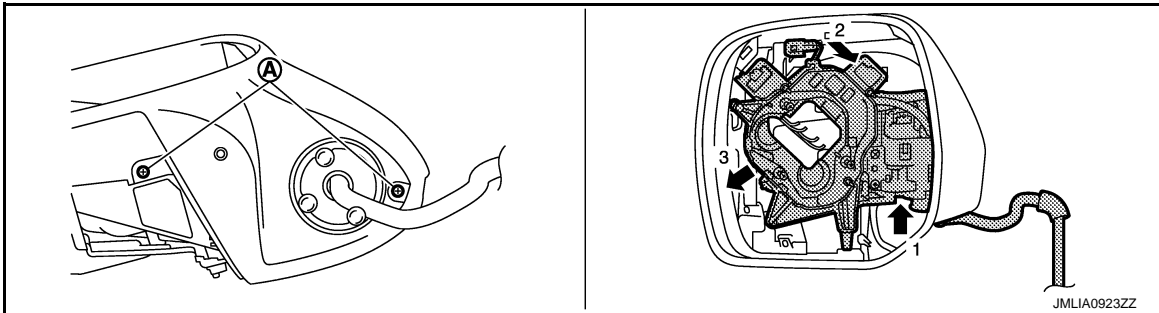

11. Remove the mounting bolts (A) and (B), and then remove actuator bracket (1) from power fold unit (2).

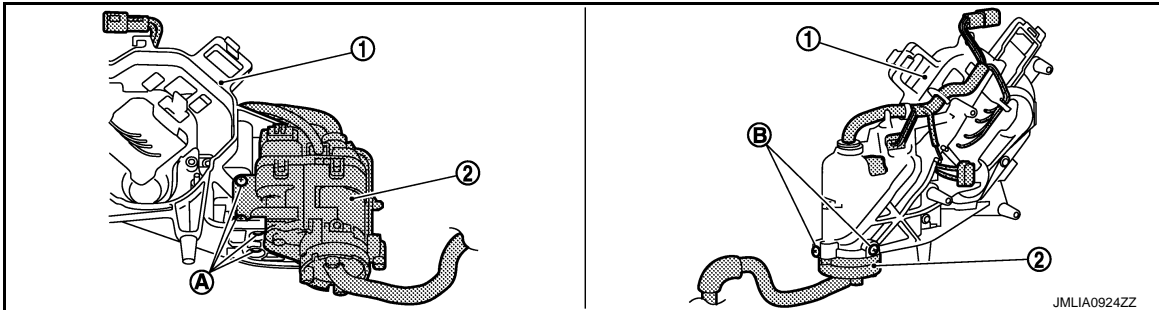

ASSEMBLY

Assemble in the reverse order of disassemble.

GLASS MIRROR

GLASS MIRROR : Removal and Installation

INFOID:000000009652720

REMOVAL

A
B
C
D
E
F
G
H
I
J
K
M
N
O
P

MIR

DOOR MIRROR

[WITH ADP]

< REMOVAL AND INSTALLATION >

1. Place the glass mirror upward.
2. As shown in the figure, insert a flat-bladed screwdriver (A) into the recess between glass mirror (1) and actuator. Push up both pawls simultaneously to remove glass mirror lower half side.

NOTE:

- Insert the screwdriver between the fixing pawls.
- Insert screwdriver into recesses, and push up while rotating (twisting) to make work easier.

CAUTION:

Put a strip of protective tape (B) on housing assembly.

3. Lift up and slide glass mirror as shown by the arrows in the figure to disengage the fixing pawls.

 : Pawl

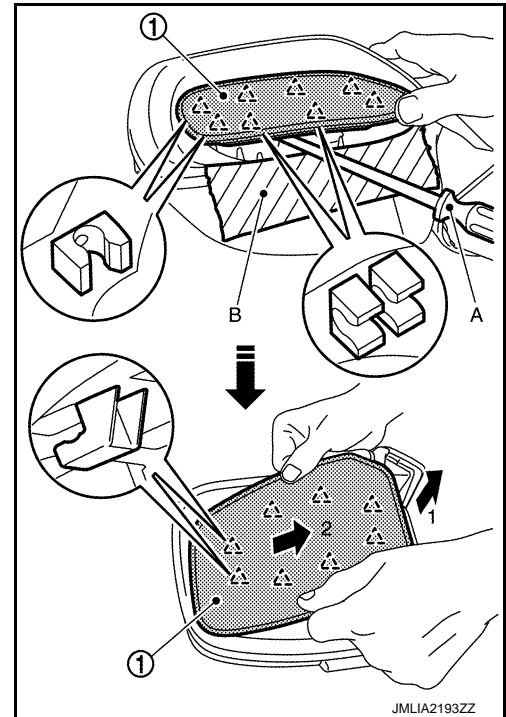

4. Remove BSW indicator harness connector (A). (if equipped)
5. Remove both terminals of mirror heater attachment (B).(if equipped)

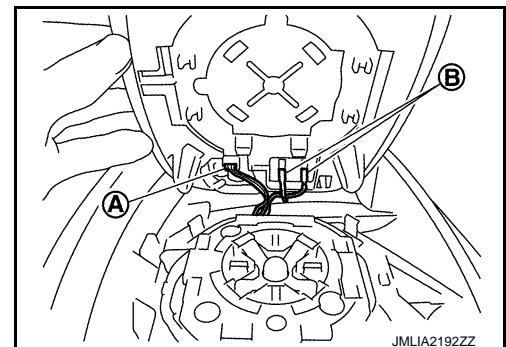

6. Lightly lift up lower side of glass mirror, and detach both pawls of upper side as if pulling it out. Remove glass mirror from actuator.

NOTE:

Be certain not to allow grease on sealing agent in center of mirror or back side of glass mirror.

INSTALLATION

Install in the reverse order of disassemble.

CAUTION:

After installation, visually check that pawls are securely engaged.

DOOR MIRROR COVER

DOOR MIRROR COVER : Removal and Installation

INFOID:000000009652721

CAUTION:

When removing, always use a remover tool that is made of plastic.

REMOVAL

1. Remove the glass mirror. Refer to [MIR-37, "GLASS MIRROR : Removal and Installation"](#).

DOOR MIRROR

< REMOVAL AND INSTALLATION >

[WITH ADP]

2. With a remover tool, disengage the fixing pawls (A).

 : Pawl

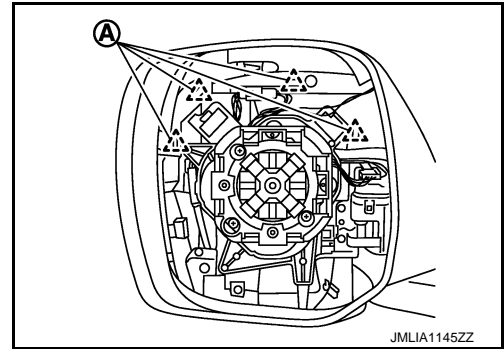

3. Insert a remover tool between door mirror cover and mirror housing to disengage the fixing pawls, and then remove the door mirror cover from the door mirror assembly.

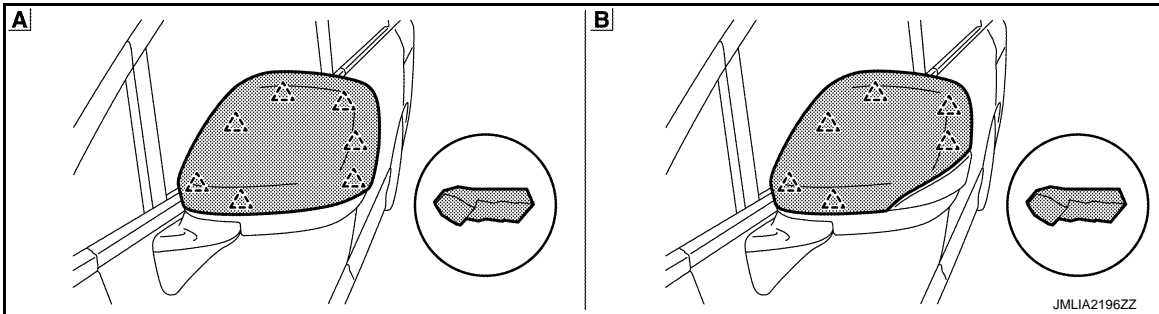

A Without side turn signal lamp

B With side turn signal lamp

 : Pawl

INSTALLATION

Install in the reverse order of disassembly.

CAUTION:

After installation, visually check that pawls are securely engaged.

A
B
C
D
E
F
G
H
I
J
K
L
M
N
O
P

MIR

DOOR MIRROR REMOTE CONTROL SWITCH

< REMOVAL AND INSTALLATION >

[WITH ADP]

DOOR MIRROR REMOTE CONTROL SWITCH

Removal and Installation

INFOID:000000009652722

REMOVAL

1. Remove the power window main switch finisher. Refer to [INT-14, "Removal and Installation"](#).
2. Remove door mirror remote control switch (1) from power window main switch finisher (2) using remover tool (A).

 : Pawl

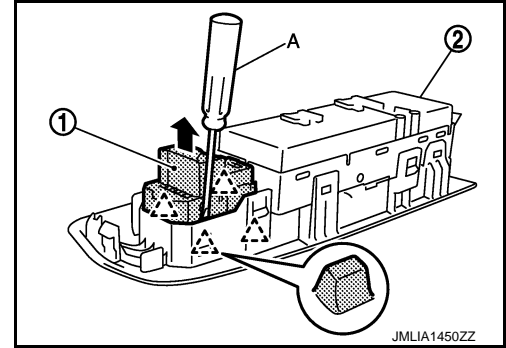

INSTALLATION

Install in the reverse order of removal.

PRECAUTION

PRECAUTIONS

Precaution for Supplemental Restraint System (SRS) "AIR BAG" and "SEAT BELT PRE-TENSIONER"

INFOID:000000009652723

The Supplemental Restraint System such as "AIR BAG" and "SEAT BELT PRE-TENSIONER", used along with a front seat belt, helps to reduce the risk or severity of injury to the driver and front passenger for certain types of collision. This system includes seat belt switch inputs and dual stage front air bag modules. The SRS system uses the seat belt switches to determine the front air bag deployment, and may only deploy one front air bag, depending on the severity of a collision and whether the front occupants are belted or unbelted. Information necessary to service the system safely is included in the "SRS AIR BAG" and "SEAT BELT" of this Service Manual.

WARNING:

Always observe the following items for preventing accidental activation.

- To avoid rendering the SRS inoperative, which could increase the risk of personal injury or death in the event of a collision that would result in air bag inflation, all maintenance must be performed by an authorized NISSAN/INFINITI dealer.
- Improper maintenance, including incorrect removal and installation of the SRS, can lead to personal injury caused by unintentional activation of the system. For removal of Spiral Cable and Air Bag Module, see "SRS AIR BAG".
- Never use electrical test equipment on any circuit related to the SRS unless instructed to in this Service Manual. SRS wiring harnesses can be identified by yellow and/or orange harnesses or harness connectors.

PRECAUTIONS WHEN USING POWER TOOLS (AIR OR ELECTRIC) AND HAMMERS

WARNING:

Always observe the following items for preventing accidental activation.

- When working near the Air Bag Diagnosis Sensor Unit or other Air Bag System sensors with the ignition ON or engine running, never use air or electric power tools or strike near the sensor(s) with a hammer. Heavy vibration could activate the sensor(s) and deploy the air bag(s), possibly causing serious injury.
- When using air or electric power tools or hammers, always switch the ignition OFF, disconnect the battery, and wait at least 3 minutes before performing any service.

Precautions for Removing Battery Terminal

INFOID:000000009900779

- When removing the 12V battery terminal, turn OFF the ignition switch and wait at least 30 seconds.

NOTE:

ECU may be active for several tens of seconds after the ignition switch is turned OFF. If the battery terminal is removed before ECU stops, then a DTC detection error or ECU data corruption may occur.

- For vehicles with the 2-batteries, be sure to connect the main battery and the sub battery before turning ON the ignition switch.

NOTE:

If the ignition switch is turned ON with any one of the terminals of main battery and sub battery disconnected, then DTC may be detected.

- After installing the 12V battery, always check "Self Diagnosis Result" of all ECUs and erase DTC.

NOTE:

The removal of 12V battery may cause a DTC detection error.

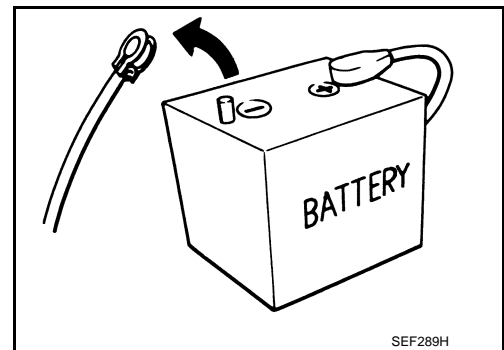

A
B
C
D
E
F
G
H
I
J
K
M
N
O
P

MIR

PREPARATION

< PREPARATION >

[WITHOUT ADP]

PREPARATION

PREPARATION

Special Service Tools

INFOID:000000009652724

The actual shapes of Kent-Moore tools may differ from those of special service tools illustrated here.

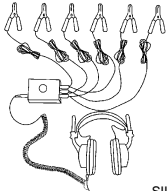
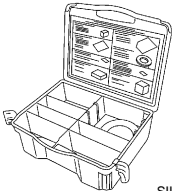
Tool number (Kent-Moore No.) Tool name	Description
<p>(J-39570) Chassis ear</p>  <p style="text-align: center;">SIIA0993E</p>	<p>Locates the noise</p>
<p>(J-50397) NISSAN Squeak and Rattle Kit</p>  <p style="text-align: center;">SIIA0994E</p>	<p>Repairs the cause of noise</p>

Commercial Service Tools

INFOID:000000009652725

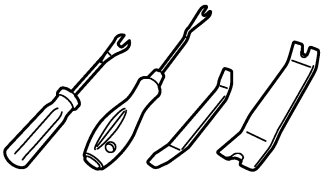
Tool name	Description
<p>Remover tool</p>  <p style="text-align: center;">JMKIA3050ZZ</p>	<p>Remove the clip, pawl and metal clip</p>

DOOR MIRROR SYSTEM

< WIRING DIAGRAM >

[WITHOUT ADP]

WIRING DIAGRAM

DOOR MIRROR SYSTEM

Wiring Diagram

INFOID:000000009652726

DOOR MIRROR (WITHOUT AUTOMATIC DRIVE POSITIONER)

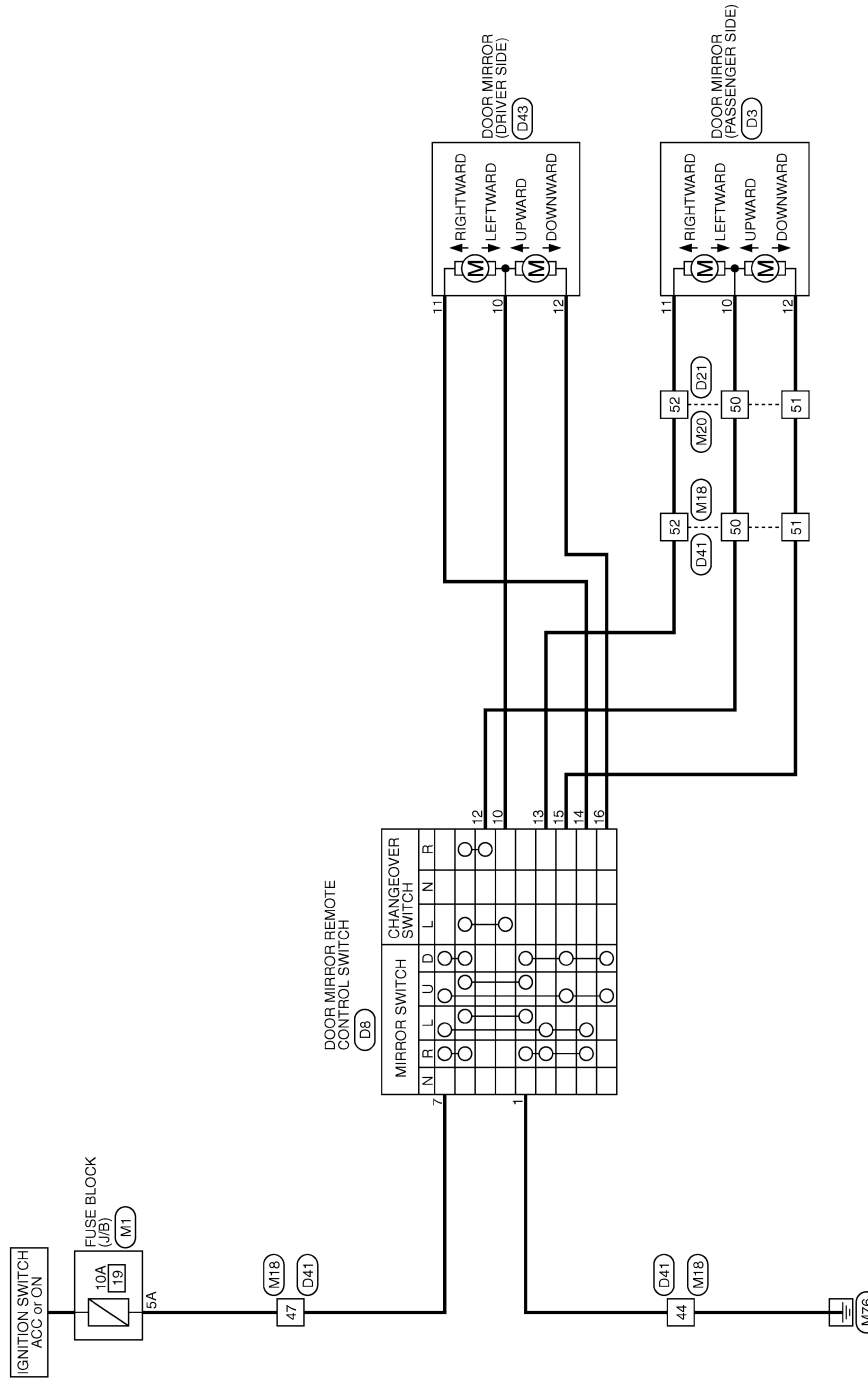

2010/12/13

JCLWA5130GB

A
B
C
D
E
F
G
H
I
J
K
L
M
N
O
P

MIR

DOOR MIRROR SYSTEM

< WIRING DIAGRAM >

[WITHOUT ADP]

DOOR MIRROR (WITHOUT AUTOMATIC DRIVE POSITIONER)

Connector No.	D3
Connector Name	DOOR MIRROR (PASSENGER SIDE)
Connector Type	TH22MK-NH



43	B	--
44	P	--
45	G	--
46	GR	--
47	BR	--
48	V	--
49	SB	--
50	SHIELD	--
51	R	--
52	BR	--

Connector No.	D21
Connector Name	WIRE TO WIRE
Connector Type	TH40FW-CS15

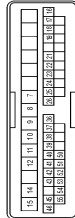

Terminal No.	Color Of Wire	Signal Name [Specification]
7	W	--
8	P	-- (Without passenger power window anti-pinch system)
9	V	-- (With front power window anti-pinch system)
10	BR	-- (Without passenger power window anti-pinch system)
11	L	-- (With front power window anti-pinch system)
12	LG	--
13	G	--
14	B	--
15	W	--
16	P	--
17	Y	--
18	R	--
19	W	--
20	B	--
21	R	--
22	SHIELD	--
23	W	--
24	G	--
25	L	--
26	LG	--
27	Y	--
28	L	--
29	Y	--
30	L	--
31	O	--
32	B	--
33	W	--
34	B	--
35	P	--
36	SB	--
37	GR	--
38	V	--
39	O	--
40	B	--
41	W	--

Connector No.	D8
Connector Name	DOOR MIRROR REMOTE CONTROL SWITCH
Connector Type	TK10FW



Terminal No.	Color Of Wire	Signal Name [Specification]
1	B	--
7	P	--
8	B	--

42	B	--
43	P	--
44	G	--
45	GR	--
46	BR	--
47	V	--
48	SB	--
49	SHIELD	--
50	G	--
51	R	--
52	BR	--
53	SHIELD	--
54	G	--
55	R	--

Connector No.	D41
Connector Name	WIRE TO WIRE
Connector Type	TH40FW-CS15

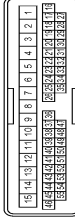

Terminal No.	Color Of Wire	Signal Name [Specification]
1	B	--
2	P	--
3	SB	--
4	GR	--
5	BR	--
6	BR	--
7	GR	--
8	V	--
9	BR	-- (With front power window anti-pinch system)
10	LG	-- (Without passenger power window anti-pinch system)
11	V	--
12	G	--
13	O	--
14	B	--
15	W	--
16	P	--
17	Y	--
18	R	--
19	W	--
20	B	--
21	R	--
22	SHIELD	--
23	W	--
24	G	--
25	L	--
26	LG	--
27	Y	--
28	L	--
29	Y	--
30	L	--
31	O	--
32	B	--
33	W	--
34	B	--
35	P	--
36	SB	--
37	GR	--
38	V	--
39	O	--
40	B	--
41	W	--

23	R	--
24	B	--
25	W	--
26	SHIELD	--
27	SB	--
28	G	--
29	V	--
30	W	--
31	O	--
32	LG	--
33	V	--
34	BR	--
35	P	--
36	SB	--
37	GR	--
38	V	--
39	V	--
40	BR	--
41	P	--
42	V	--
43	Y	--
44	B	--
45	B	-- (Without automatic drive positioner)
46	P	-- (With automatic drive positioner)
47	W	-- (Without automatic drive positioner)
48	W	-- (With automatic drive positioner)
49	P	--
50	B	--
51	G	-- (Without automatic drive positioner)
52	SB	-- (With automatic drive positioner)
53	LG	--
54	G	--
55	R	--

DOOR MIRROR SYSTEM

< WIRING DIAGRAM >

[WITHOUT ADP]

DOOR MIRROR (WITHOUT AUTOMATIC DRIVE POSITIONER)

Connector No.	D43
Connector Name	DOOR MIRROR (DRIVER SIDE)
Connector Type	11E24MM-NH



Connector No.	M18
Connector Name	WIRE TO WIRE
Connector Type	1H40MM-CS15

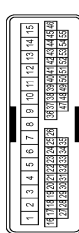

Terminal No.	Color Of Wire	Signal Name [Specification]
1	W	
2	W	
3	B	
4	SB	
5	SB	
6	LG	
7	SB	
8	SB	
9	SB	
10	Y	
11	Y	
12	BR	
13	B	
14	SHIELD	
15	B	
16	B	
17	B	
18	B	
19	B	
20	V	
21	LG	
22	R	
23	GR	
24	L	

Connector No.	M1
Connector Name	FUSE BLOCK (J/B)
Connector Type	NS06FW-ME



Terminal No.	Color Of Wire	Signal Name [Specification]
1A	Y	
2A	G	
3A	L	
4A	GR	

Connector No.	M18
Connector Name	WIRE TO WIRE
Connector Type	1H40MM-CS15



Terminal No.	Color Of Wire	Signal Name [Specification]
1	B/W	
2	R	
3	W	
4	Y	
5	SB	
6	BR	
7	LG	
8	L	
9	GR	
10	V	
11	V	
12	G	
13	O	
14	BR	
15	G	
16	Y	
17	SB	
18	P	
19	V	
20	Y	
21	W	
22	G	
23	B	
24	SHIELD	
25	W	
26	W/R	
27	G	
28	W	
29	W	
30	P	
31	G	
32	G	
33	G	
34	B	
35	G	
36	G	
37	V	
38	P	
39	V	
40	BR	
41	P	
42	V	
43	SB	
44	B	
45	W	
46	V	
47	V	
48	B/P	
49	O	
50	R/W	
51	V	
52	W	
53	SHIELD	
54	L/R	
55	L/G	

Connector No.	M20
Connector Name	WIRE TO WIRE
Connector Type	1H40MM-CS15

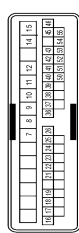

Terminal No.	Color Of Wire	Signal Name [Specification]
7	B/W	
8	L	
9	P	
9	BR	
9	GR	

10	LG	--
11	SB	--
12	Y	--
13	B	--
14	B	--
15	W	--
16	BR	--
17	P	--
18	R	--
19	Y	--
21	R	--
22	B	--
23	W	--
24	SHIELD	--
25	W/L	--
26	W/R	--
27	G	--
28	W	--
29	W	--
30	P	--
38	G	--
40	B	--
41	R	--
42	L	--
43	GR	--
45	BR	--
46	GR	--
50	V	--
51	BR	-- [With automatic drive positioner]
51	LG	-- [Without automatic drive positioner]
52	SHIELD	--
53	SB/V	--
55	LG	--

A
B
C
D
E
F
G
H
I
J
K
L
M
N
O
P

MIR

AUTO ANTI-DAZZLING INSIDE MIRROR SYSTEM

< WIRING DIAGRAM >

[WITHOUT ADP]

AUTO ANTI-DAZZLING INSIDE MIRROR SYSTEM

Wiring Diagram

INFOID:000000009652727

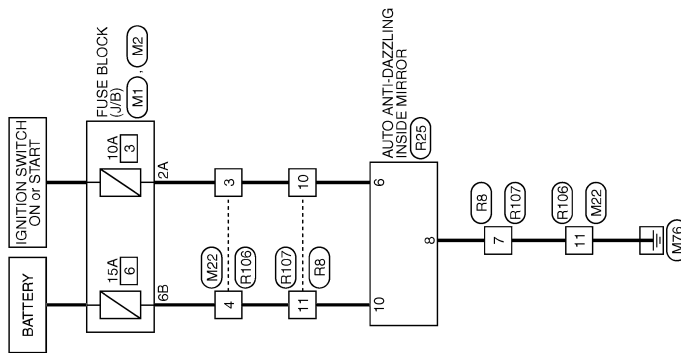

INSIDE MIRROR

2012/07/19

JRLWC2666GB

AUTO ANTI-DAZZLING INSIDE MIRROR SYSTEM

< WIRING DIAGRAM >

[WITHOUT ADP]

INSIDE MIRROR

Connector No.	M1
Connector Name	FUSE BLOCK (J/B)
Connector Type	NS56FW-M2

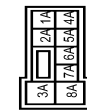

Terminal No.	Color Of Wire	Signal Name [Specification]
1A	Y	--
2A	G	--
3A	L	--
4A	GR	--
5A	V	--
6A	R	--
7A	GR	--
8A	L	--

Connector No.	M2
Connector Name	FUSE BLOCK (J/B)
Connector Type	NS10FW-CS

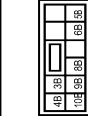

Terminal No.	Color Of Wire	Signal Name [Specification]
10B	R	--
3B	V	--
4B	W	--
5B	BR	--
8B	O	--
9B	GR	--

Connector No.	M22
Connector Name	WIRE TO WIRE
Connector Type	TH10FW-NH



Terminal No.	Color Of Wire	Signal Name [Specification]
5	BR	--
6	BR	--
7	BR	--
8	GR	--
9	P	--
10	R	--
11	B/W	--
12	B	--
13	R	--
14	W/L	-- [Without MAV]
15	Y	-- [Without MAV]
16	SHIELD	-- [Without MAV]
17	W/R	-- [Without MAV]
18	W/R	-- [Without MAV]

Connector No.	FR
Connector Name	WIRE TO WIRE
Connector Type	TH12FW-NH

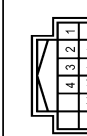

Terminal No.	Color Of Wire	Signal Name [Specification]
1	W/L	--
2	BR	--
3	BR/R	-- [With manual A/C]
4	V	-- [With manual A/C]
5	R	-- [With manual A/C]
6	O	-- [With manual A/C]
7	B	-- [With manual A/C]
8	O	--
9	P	--
10	V	--
11	BR	--

Connector No.	R25
Connector Name	AUTO ANTI-DAZZLING INSIDE MIRROR
Connector Type	TH10FF-NH

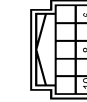

Terminal No.	Color Of Wire	Signal Name [Specification]
8	W/L	--
9	G	--
10	BR	--

Connector No.	R106
Connector Name	WIRE TO WIRE
Connector Type	TH10MW-NH



Terminal No.	Color Of Wire	Signal Name [Specification]
1	G	--
2	SB	--
3	P	--
4	LG	--
5	O	--
6	O	--
7	W	--
8	BR	--
9	L	--
10	LG	--
11	B	--
12	V	--
13	Y	--
14	SHIELD	--
15	BR	--

Connector No.	R107
Connector Name	WIRE TO WIRE
Connector Type	TH12MW-NH

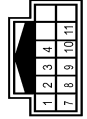

Terminal No.	Color Of Wire	Signal Name [Specification]
1	P	--
2	SB	--
3	G	--
4	Y	--
7	B	--
8	R	--
9	L	--
10	P	--
11	LG	--

A
B
C
D
E
F
G
H
I
J
K
L
M
N
O
P

MIR

INSIDE MIRROR

< REMOVAL AND INSTALLATION >

[WITHOUT ADP]

REMOVAL AND INSTALLATION

INSIDE MIRROR

Exploded View

INFOID:000000009652728

Manual anti-dazzling type

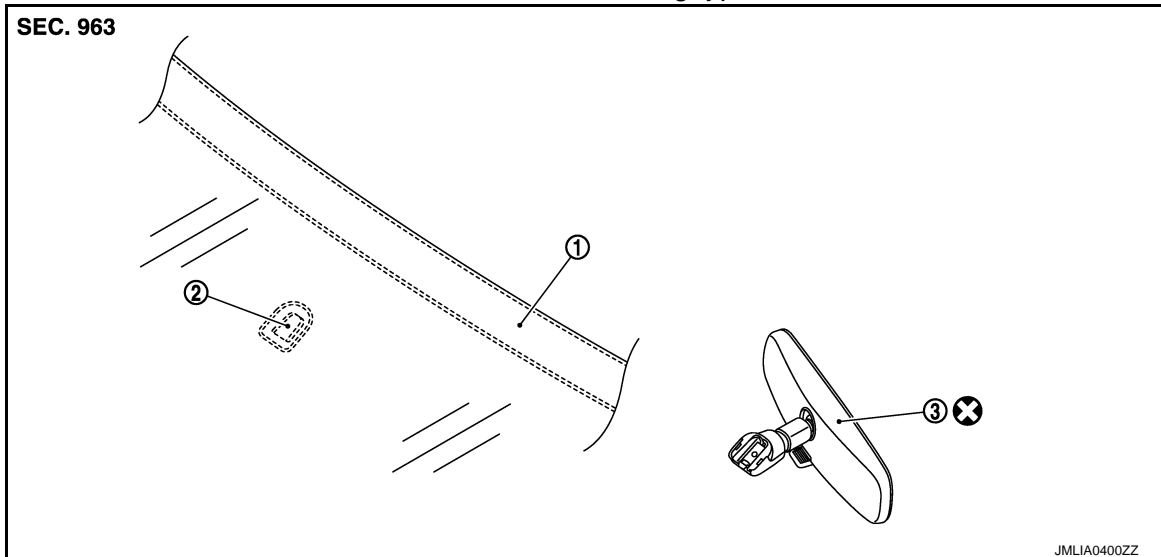

1. Windshield glass 2. Inside mirror base 3. Inside mirror assembly

⊗ : Always replace after every disassembly.

Auto anti-dazzling type

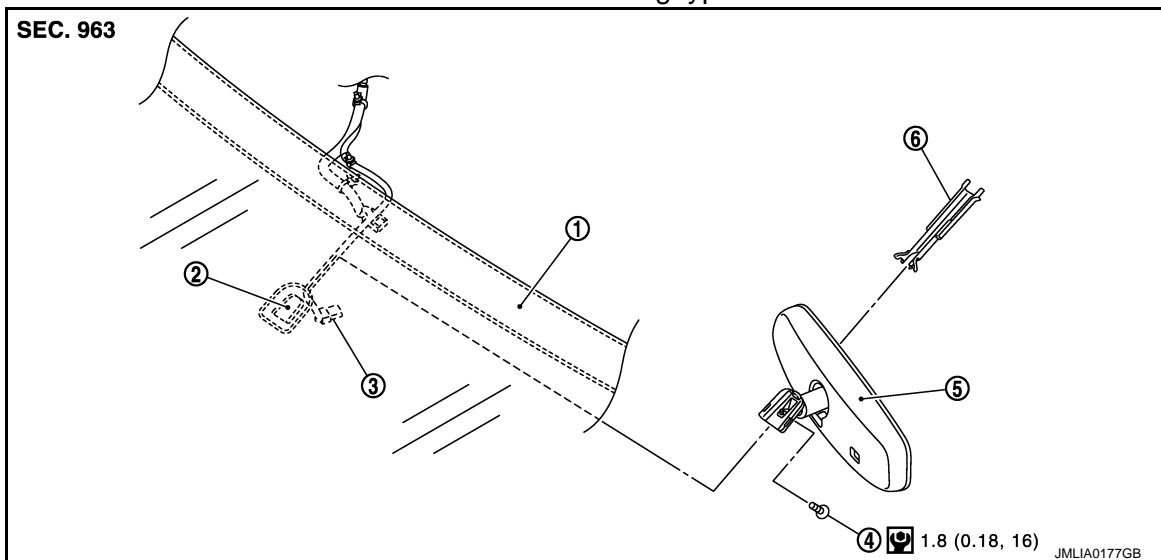

1. Windshield glass 2. Inside mirror base 3. Harness connector
4. TORX bolt 5. Inside mirror assembly 6. Inside mirror cover

⊙ : N-m (kg-m, in-lb)

Removal and Installation

INFOID:000000009652729

REMOVAL

Manual anti-dazzling type

INSIDE MIRROR

< REMOVAL AND INSTALLATION >

[WITHOUT ADP]

1. Insert a flat-bladed screwdriver (A) under the inside mirror (1).
2. Slide the inside mirror to the upper side while pushing the pawl downward.

⊗ : Always replace after every disassembly

CAUTION:

- Never reuse the inside mirror disassembled from inside mirror base.
- Never use excessive force to remove the inside mirror because it is inserted tightly into the mirror base.
- Wrap the flat-bladed screwdriver with a shop cloth to avoid damage on the windshield glass.

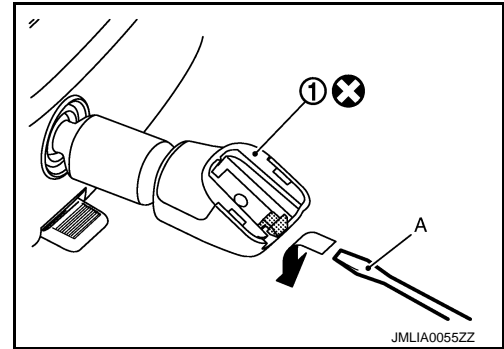

Auto anti-dazzling type

1. Remove inside mirror cover.
2. Disconnect harness connector from inside mirror.
3. Loosen TORX bolt and slide inside mirror upward to remove.

INSTALLATION

Install in the reverse order of removal.

CAUTION:

When inserting the inside mirror into the mirror base, be sure to push the pawl until it get connected to the mirror base (manual anti-dazzling type only).

A
B
C
D
E
F
G
H
I
J
K
M
N
O
P

MIR

DOOR MIRROR

< REMOVAL AND INSTALLATION >

[WITHOUT ADP]

DOOR MIRROR

Exploded View

INFOID:000000009652730

Models with around view camera

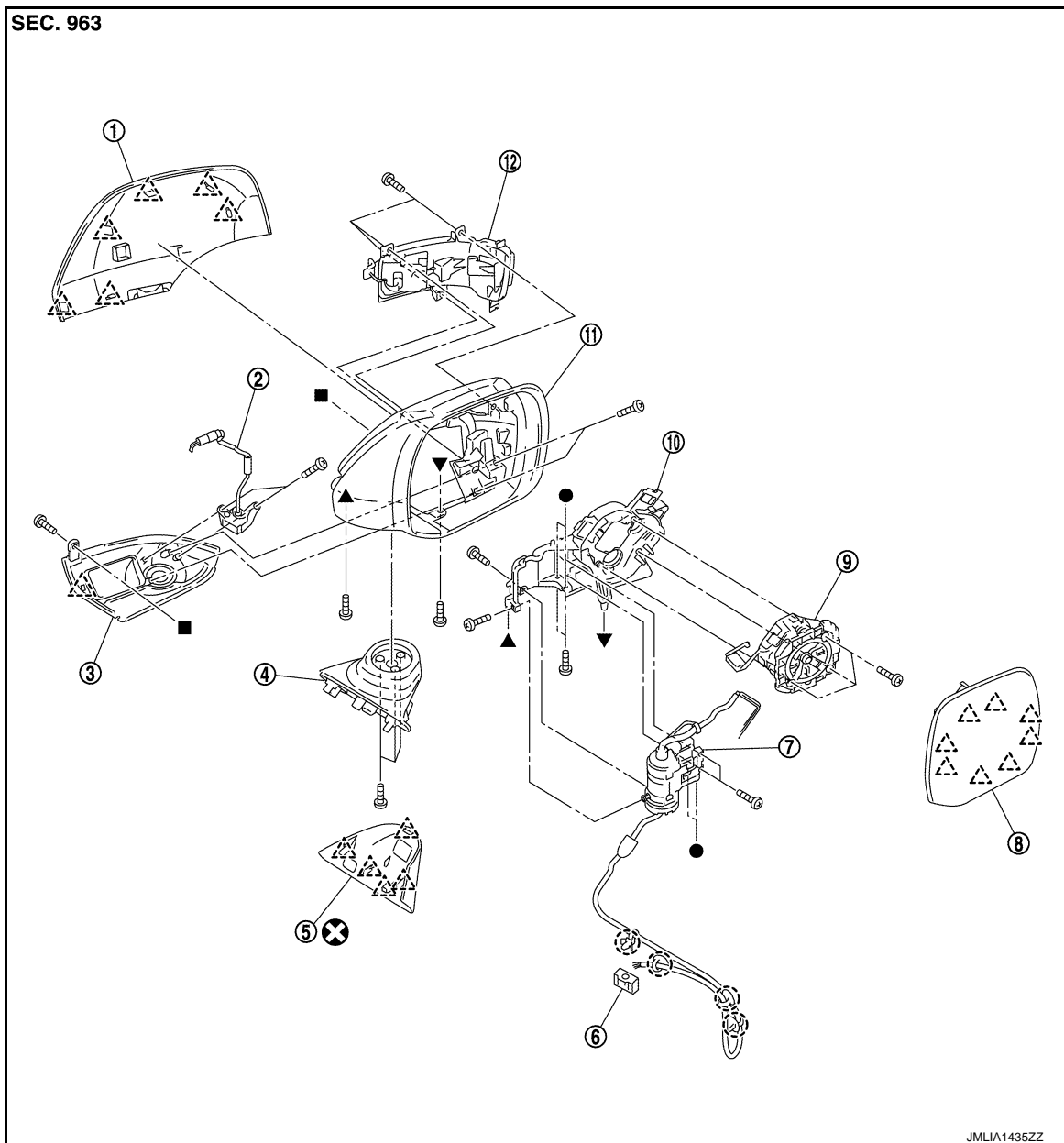

- | | | |
|----------------------|-----------------------------|--------------------------------|
| 1. Door mirror cover | 2. Around view camera | 3. Around view camera finisher |
| 4. Door mirror base | 5. Door mirror corner cover | 6. Connector |
| 7. Power fold unit | 8. Glass mirror | 9. Actuator |
| 10. Actuator bracket | 11. Door mirror housing | 12. Side turn signal lamp |

○ : Clip

△ : Pawl

⊗ : Always replace after every disassembly.

●, ▲, ■, ▼ : Indicates that the part is connected at points with same symbol in actual vehicle.

DOOR MIRROR

< REMOVAL AND INSTALLATION >

[WITHOUT ADP]

Models with side turn signal lamp

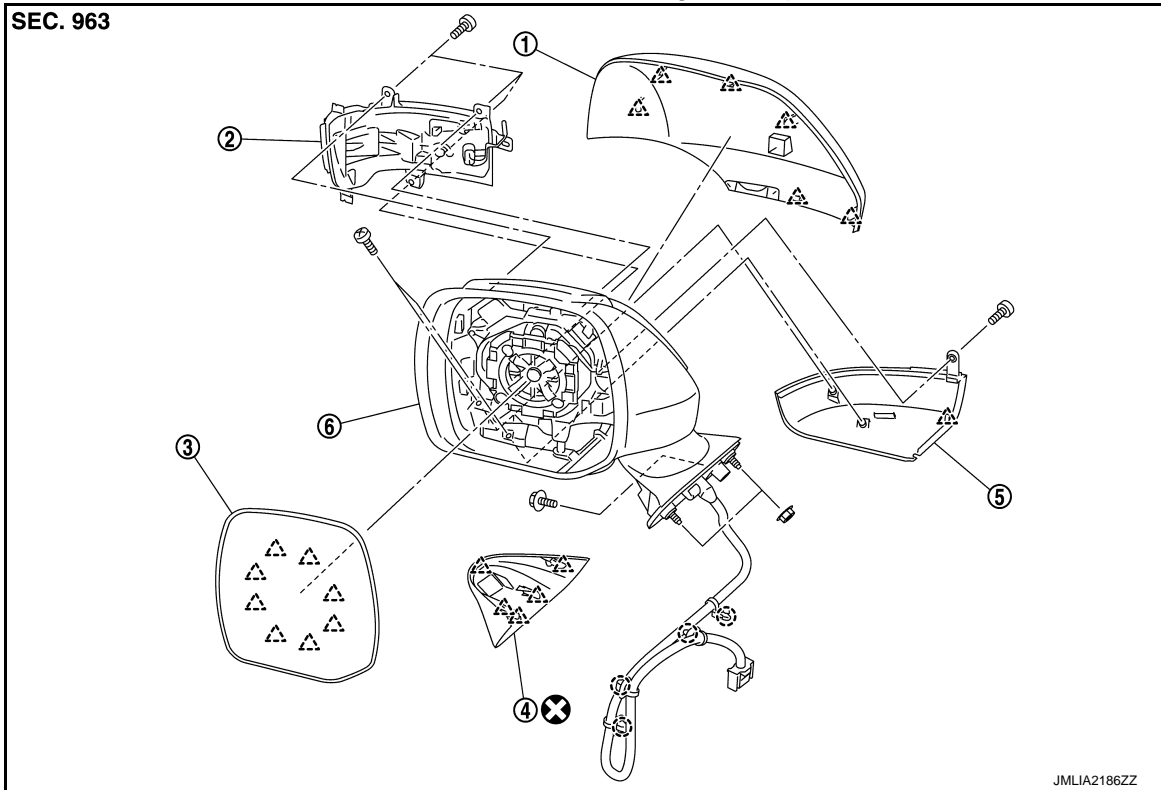

- | | | |
|-----------------------------|----------------------------|-----------------|
| 1. Door mirror cover | 2. Side turn signal lamp | 3. Glass mirror |
| 4. Door mirror corner cover | 5. Door mirror under cover | 6. Door mirror |

○ : Clip

△ : Pawl

⊗ : Always replace after every disassembly.

A
B
C
D
E
F
G
H
I
J
K
L
M
N
O
P

MIR

DOOR MIRROR

< REMOVAL AND INSTALLATION >

[WITHOUT ADP]

Models without side turn signal lamp

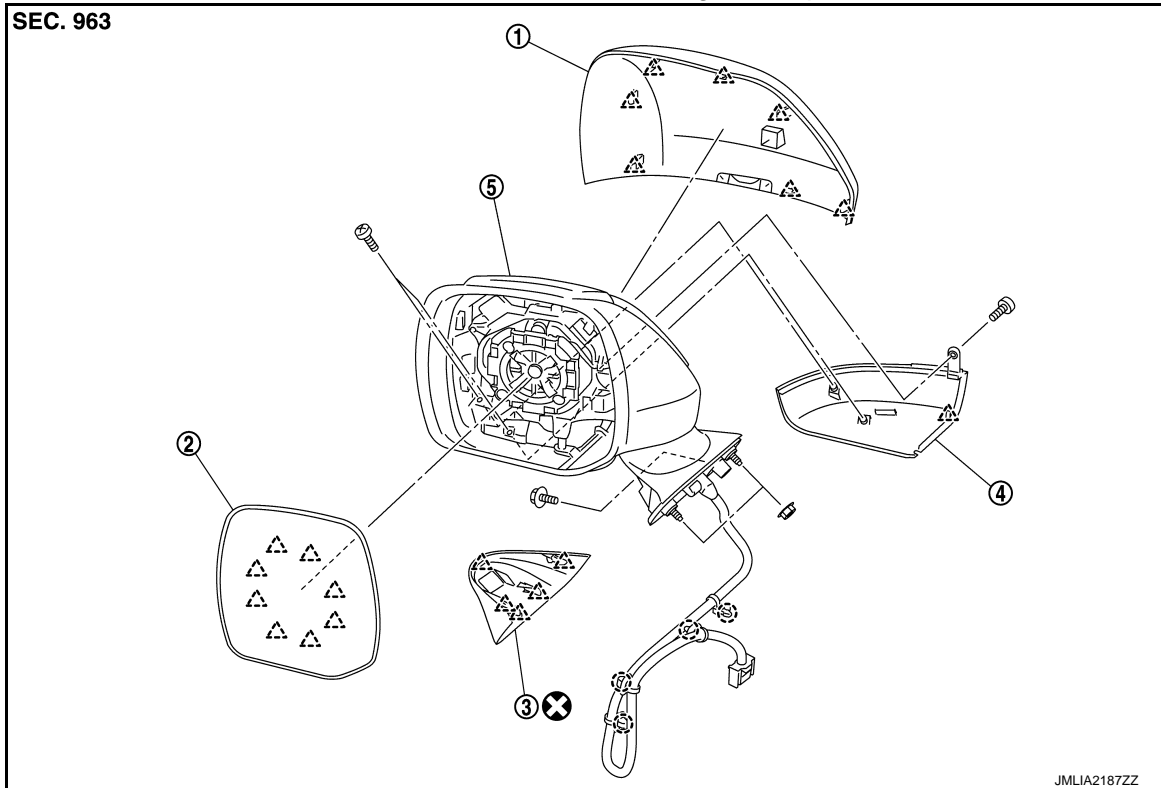

- | | | |
|----------------------------|-----------------|-----------------------------|
| 1. Door mirror cover | 2. Glass mirror | 3. Door mirror corner cover |
| 4. Door mirror under cover | 5. Door mirror | |

○ : Clip

△ : Pawl

⊗ : Always replace after every disassembly.

DOOR MIRROR ASSEMBLY

DOOR MIRROR ASSEMBLY : Removal and Installation

INFOID:000000009652731

CAUTION:

- When removing, always use a remover tool that is made of plastic.
- Be careful not to scratch or damage door mirror body when removing.
- Always replace door mirror corner cover after every disassembly.

REMOVAL

1. Remove front door finisher. Refer to [INT-14, "Removal and Installation"](#).
2. Remove front door module assembly mounting bolts, pull out the front door module assembly to make space in order to disengage the harness connector.

DOOR MIRROR

< REMOVAL AND INSTALLATION >

[WITHOUT ADP]



3. Remove harness connector (A).
4. Remove front door speaker and then, from the hole of front door speaker disconnect the harness connectors.

 : Clip

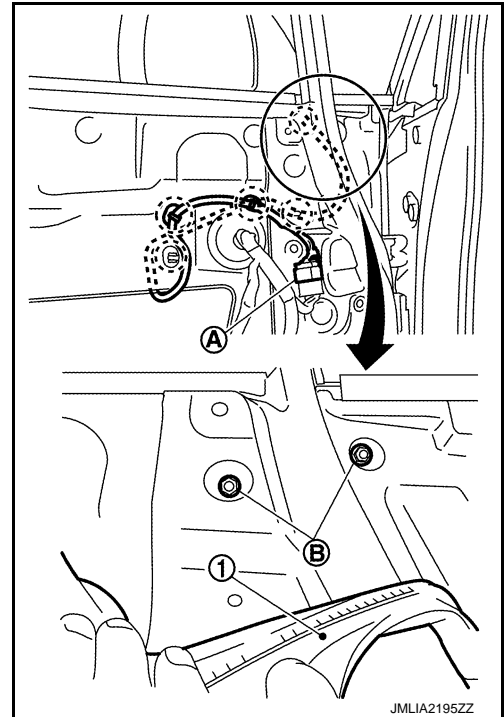
5. Peel off front door weather-strip (1), and then remove door mirror mounting nuts (B).





6. Remove door mirror corner cover.
 - a. Disengage the door mirror corner cover fixing pawls with remover tool (A). (front door side)

 : Pawl
 : Vehicle front

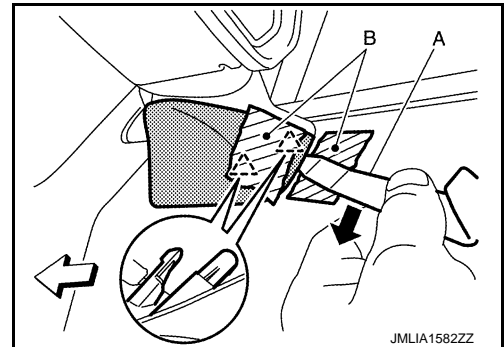
CAUTION:
Apply protective tape (B) on the part to protect it from damage.



- b. Disengage the door mirror corner cover fixing pawls with remover tool (A). (front fender side)

 : Pawl
 : Vehicle front

CAUTION:
Apply protective tape (B) on the part to protect it from damage.

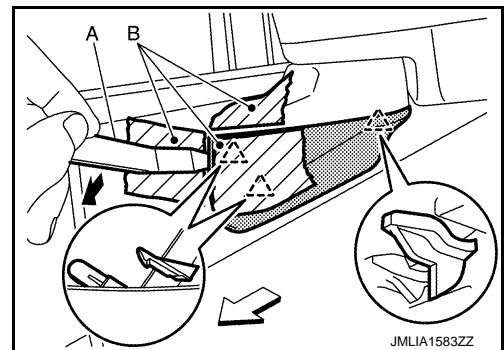

7. Remove door mirror mounting bolt.
8. Remove door mirror assembly from door panel.

INSTALLATION

1. Insert door mirror harness connector through the door outer panel hole.
2. Install door mirror assembly into the door panel and tighten the mounting bolt and nuts.
3. Install the door mirror harness fixing clips to the door panel from the hole of door speaker.
4. Install front door finisher.

DOOR MIRROR

< REMOVAL AND INSTALLATION >

[WITHOUT ADP]

DOOR MIRROR ASSEMBLY : Disassembly and Assembly

INFOID:000000009652732

CAUTION:

When removing, always use a remover tool that is made of plastic.

DISASSEMBLY

1. Remove door mirror assembly from the door panel. Refer to [MIR-52, "DOOR MIRROR ASSEMBLY : Removal and Installation"](#).
2. Remove glass mirror. Refer to [MIR-56, "GLASS MIRROR : Removal and Installation"](#).
3. Remove door mirror cover. Refer to [MIR-57, "DOOR MIRROR COVER : Removal and Installation"](#).
4. Remove door mirror actuator (1).
 - a. Remove the mounting screws (A).
 - b. Disconnect the harness connectors behind the actuator.

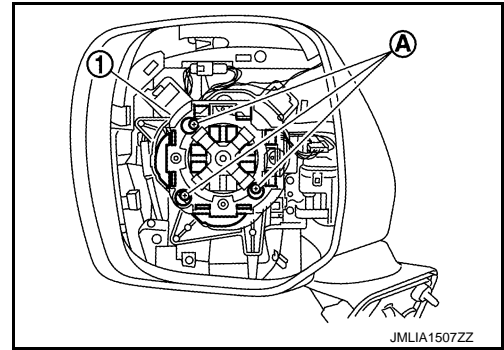

5. Remove around view camera finisher assembly (1). (with around view camera)

1. Remove around view camera finisher mounting screw (A).

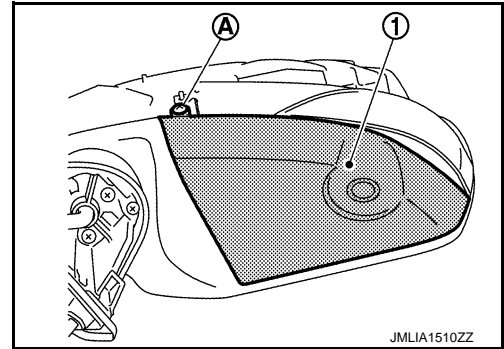

2. Disconnect harness connector (B) and remove mounting screws (C).
3. Disengage around view camera finisher assembly (1) fixing pawls and remove it from door mirror housing.

 : Pawl

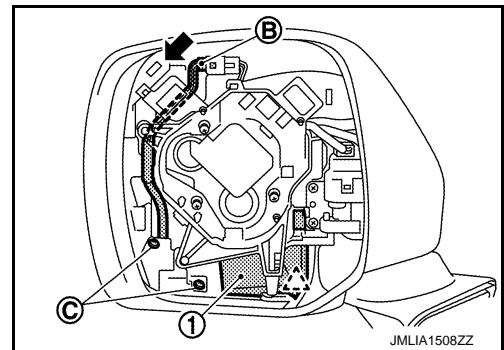

6. Remove around view camera mounting screws and then remove it from around view camera finisher. Refer to [AV-631, "Removal and Installation"](#).
7. Remove door mirror under cover (1). (with side turn signal lamp)

DOOR MIRROR

< REMOVAL AND INSTALLATION >

[WITHOUT ADP]

- a. Remove door mirror under cover mounting screw (A).

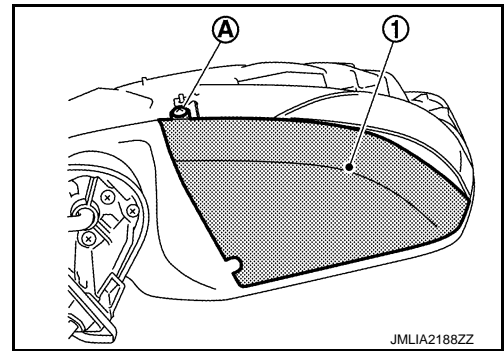

- b. Remove door mirror under cover mounting screws (A) and disengage the fixing pawl.

 : Pawl

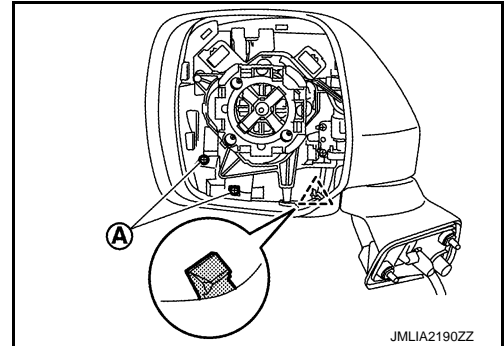

- c. Remove door mirror side turn signal lamp mounting screws (A) and remove side turn signal lamp.

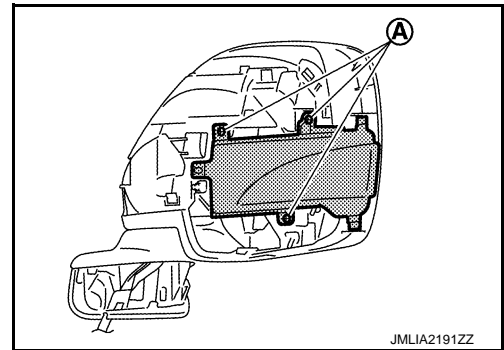

8. Remove door mirror under cover (1). (without side turn signal lamp)

- a. Remove door mirror under cover mounting screw (A).

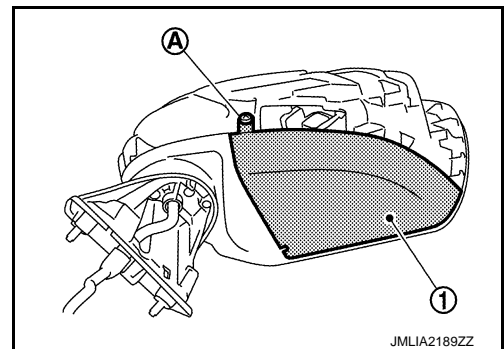

A
B
C
D
E
F
G
H
I
J
K
M
N
O
P

MIR

DOOR MIRROR

< REMOVAL AND INSTALLATION >

[WITHOUT ADP]

- b. Remove door mirror under cover mounting screws (A) and disengage the fixing pawl.

 : Pawl

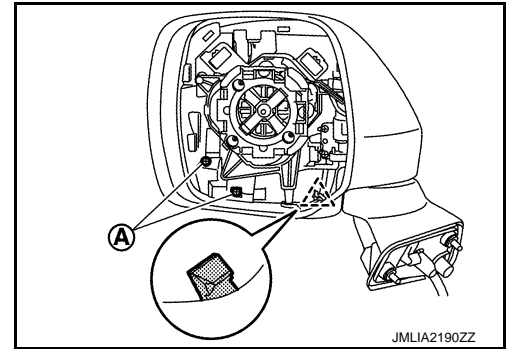

9. Remove the mounting bolts (A) and remove door mirror base from door mirror housing.

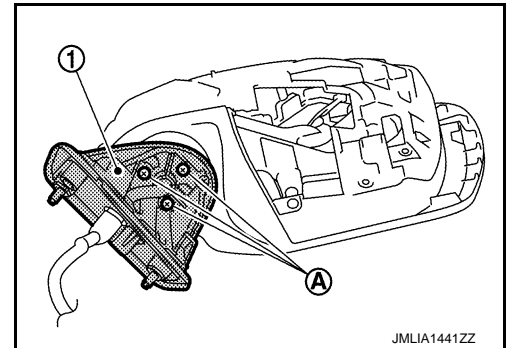

10. Remove power fold unit.

- a. Remove power fold unit assembly fixing screws (A).
b. Remove power fold unit assembly from door mirror housing according to the numerical order shown in the figure below.

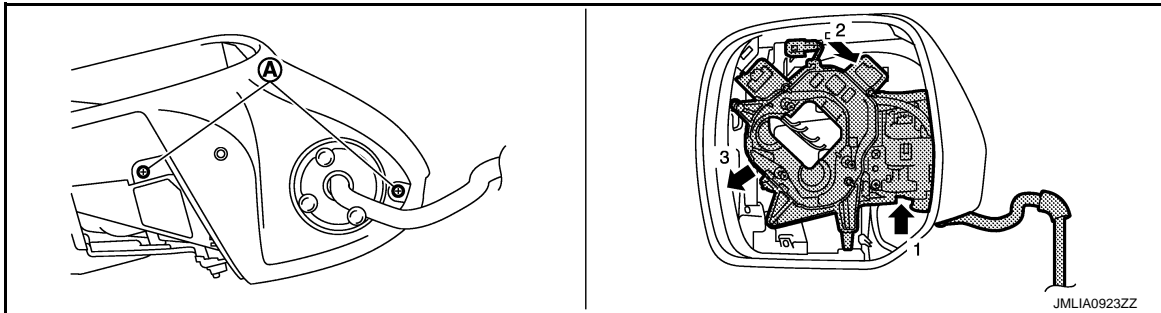

11. Remove the mounting bolts (A) and (B), and then remove actuator bracket (1) from power fold unit (2).

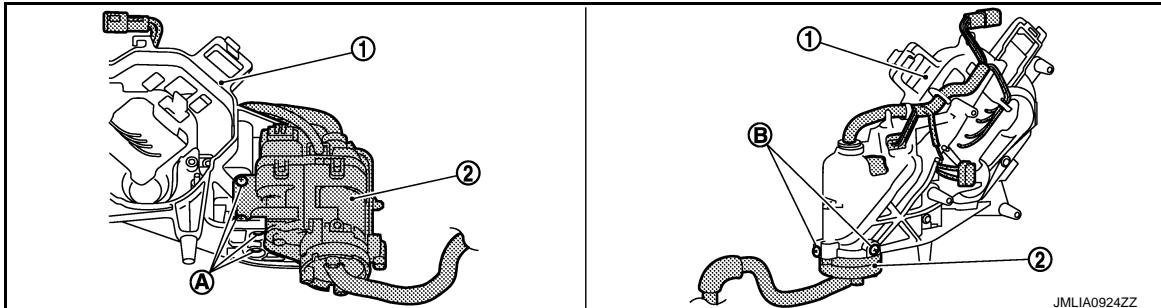

ASSEMBLY

Assemble in the reverse order of disassemble.

GLASS MIRROR

GLASS MIRROR : Removal and Installation

INFOID:000000009652733

REMOVAL

DOOR MIRROR

< REMOVAL AND INSTALLATION >

[WITHOUT ADP]

1. Place the glass mirror upward.
2. As shown in the figure, insert a flat-bladed screwdriver (A) into the recess between glass mirror (1) and actuator. Push up both pawls simultaneously to remove glass mirror lower half side.

NOTE:

- Insert the screwdriver between the fixing pawls.
- Insert screwdriver into recesses, and push up while rotating (twisting) to make work easier.

CAUTION:

Put a strip of protective tape (B) on housing assembly.

3. Lift up and slide glass mirror as shown by the arrows in the figure to disengage the fixing pawls.

 : Pawl

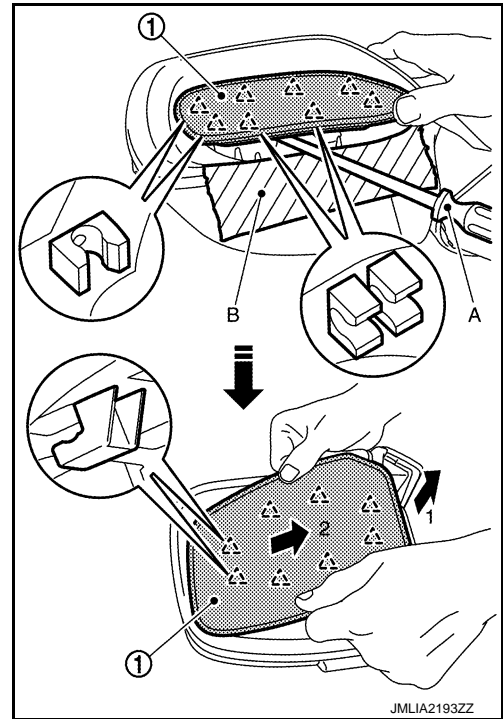

4. Remove BSW indicator harness connector (A). (if equipped)
5. Remove both terminals of mirror heater attachment (B).(if equipped)

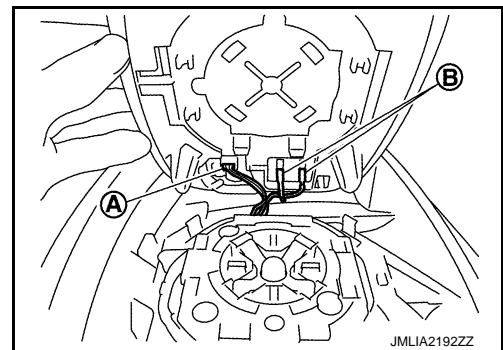

6. Lightly lift up lower side of glass mirror, and detach both pawls of upper side as if pulling it out. Remove glass mirror from actuator.

NOTE:

Be certain not to allow grease on sealing agent in center of mirror or back side of glass mirror.

INSTALLATION

Install in the reverse order of disassemble.

CAUTION:

After installation, visually check that pawls are securely engaged.

DOOR MIRROR COVER

DOOR MIRROR COVER : Removal and Installation

INFOID:000000009652734

CAUTION:

When removing, always use a remover tool that is made of plastic.

REMOVAL

1. Remove the glass mirror. Refer to [MIR-56, "GLASS MIRROR : Removal and Installation"](#).

A
B
C
D
E
F
G
H
I
J
K
M
N
O
P

MIR

DOOR MIRROR

< REMOVAL AND INSTALLATION >

[WITHOUT ADP]

2. With a remover tool, disengage the fixing pawls (A).

 : Pawl

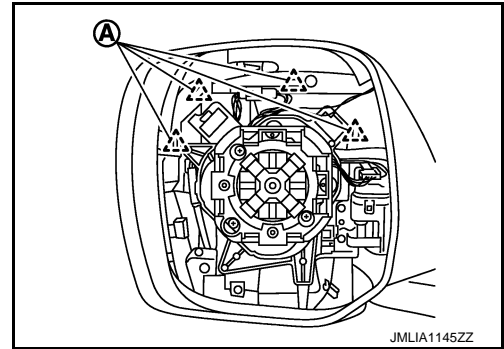

3. Insert a remover tool between door mirror cover and mirror housing to disengage the fixing pawls, and then remove the door mirror cover from the door mirror assembly.

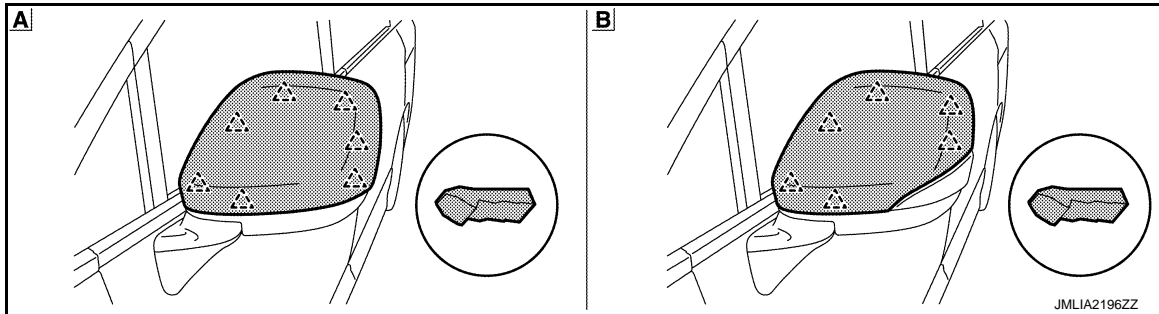

A Without side turn signal lamp

B With side turn signal lamp

 : Pawl

INSTALLATION

Install in the reverse order of disassemble.

CAUTION:

After installation, visually check that pawls are securely engaged.

DOOR MIRROR REMOTE CONTROL SWITCH

< REMOVAL AND INSTALLATION >

[WITHOUT ADP]

DOOR MIRROR REMOTE CONTROL SWITCH

Removal and Installation

INFOID:000000009652735

REMOVAL

1. Remove the power window main switch finisher. Refer to [INT-14. "Removal and Installation"](#).
2. Remove door mirror remote control switch (1) from power window main switch finisher (2) using remover tool (A).

 : Pawl

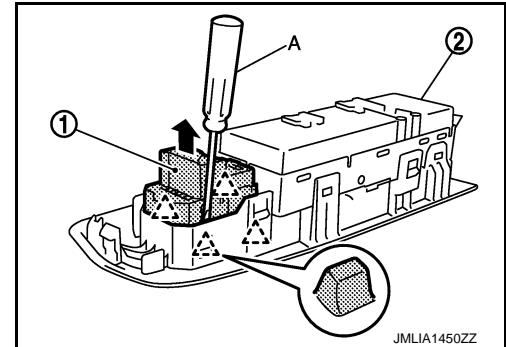

INSTALLATION

Install in the reverse order of removal.

A
B
C
D
E
F
G
H
I
J
K
L
M
N
O
P

MIR