

SECTION **RAX**
REAR AXLE

A
B
C

RAX

CONTENTS

E

PREPARATION	2	REMOVAL AND INSTALLATION	5	F
PREPARATION	2	REAR WHEEL HUB AND HOUSING	5	
Commercial Service Tools	2	Exploded View	5	G
SYMPTOM DIAGNOSIS	3	Removal and Installation	6	
NOISE, VIBRATION AND HARSHNESS		Inspection	7	
(NVH) TROUBLESHOOTING	3	SERVICE DATA AND SPECIFICATIONS		H
NVH Troubleshooting Chart	3	(SDS)	8	
PERIODIC MAINTENANCE	4	SERVICE DATA AND SPECIFICATIONS		I
REAR WHEEL HUB	4	(SDS)	8	
Inspection	4	Wheel Bearing	8	J

J

K

L

M

N

O

P

PREPARATION

< PREPARATION >

PREPARATION

PREPARATION

Commercial Service Tools

INFOID:000000009650472

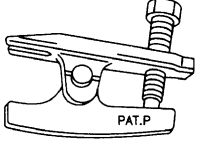
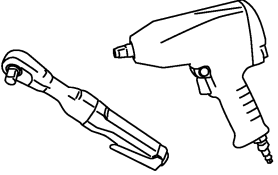
Tool name	Description
<p data-bbox="154 415 332 441">Ball joint remover</p>  <p data-bbox="880 632 927 646">NT146</p>	<ul data-bbox="1052 415 1464 472" style="list-style-type: none">• Removing ball joint for suspension arm• Removing hub bolt
<p data-bbox="154 667 267 693">Power tool</p>  <p data-bbox="880 884 954 898">PBIC0190E</p>	<p data-bbox="1052 667 1307 693">Loosening bolts and nuts</p>

NOISE, VIBRATION AND HARSHNESS (NVH) TROUBLESHOOTING

< SYMPTOM DIAGNOSIS >

SYMPTOM DIAGNOSIS

NOISE, VIBRATION AND HARSHNESS (NVH) TROUBLESHOOTING

NVH Troubleshooting Chart

INFOID:000000009650473

Use chart below to find the cause of the symptom. If necessary, repair or replace these parts.

Reference		RAX-5. "Exploded View"	—	RAX-4. "Inspection"	NVH in RAX and RSU sections	NVH in WT section	NVH in WT section	NVH in BR section
Possible cause and SUSPECTED PARTS		Improper installation, looseness	Parts interference	Wheel bearing damage	REAR AXLE AND REAR SUSPENSION	TIRE	ROAD WHEEL	BRAKE
Symptom	REAR AXLE	Noise	x	x	x	x	x	x
		Shake	x	x	x	x	x	x
		Vibration	x	x	x	x	x	x
		Shimmy	x	x		x	x	x
		Judder	x			x	x	x
		Poor quality ride or handling	x	x		x	x	x

x: Applicable

A
B
C
RAX
E
F
G
H
I
J
K
L
M
N
O
P

REAR WHEEL HUB

< PERIODIC MAINTENANCE >

PERIODIC MAINTENANCE

REAR WHEEL HUB

Inspection

INFOID:000000009650474

COMPONENT PART

Check the mounting conditions (looseness, back lash) of each component and component conditions (wear, damage) are normal.

WHEEL HUB ASSEMBLY (BEARING-INTEGRATED TYPE)

Check the following items, and replace the part if necessary.

- Move wheel hub assembly in the axial direction by hand. Check there is no looseness of wheel bearing.

Axial end play : Refer to [RAX-8, "Wheel Bearing"](#).

- Rotate wheel hub assembly and check there is no unusual noise or other irregular conditions. If there is any of irregular conditions, replace wheel hub assembly.

REAR WHEEL HUB AND HOUSING

< REMOVAL AND INSTALLATION >

REMOVAL AND INSTALLATION

REAR WHEEL HUB AND HOUSING

Exploded View

INFOID:000000009650475

Except for 3.5LE Grade

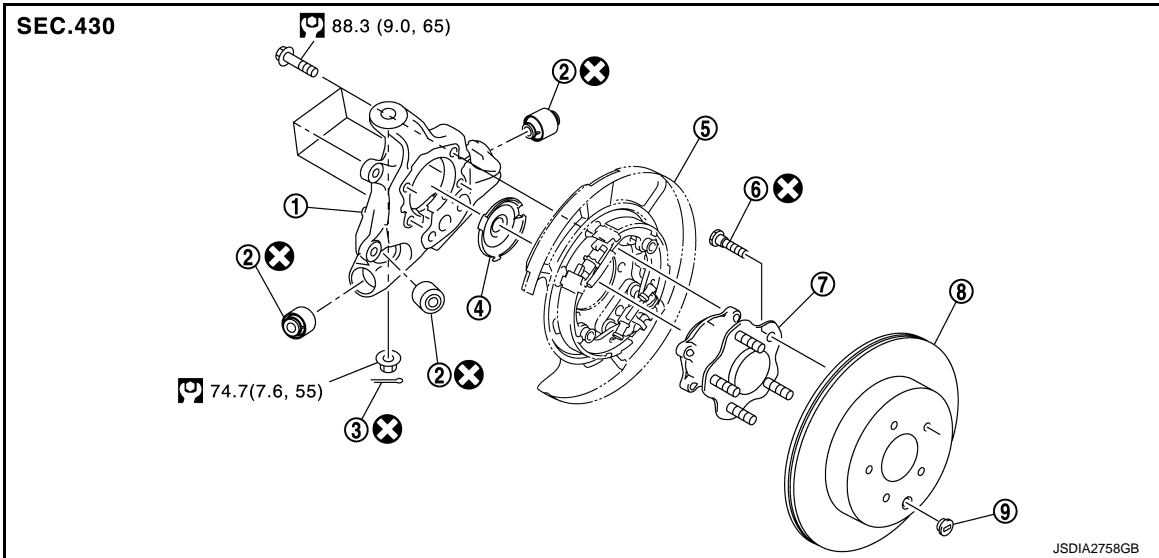

- | | | |
|---|--------------------------------|---------------|
| 1. Axle housing | 2. Bushing | 3. Cotter pin |
| 4. Hub cap | 5. Parking brake shoe assembly | 6. Hub bolt |
| 7. Wheel hub assembly (Bearing-integrated type) | 8. Disc rotor | 9. Plug |

: N·m (kg-m, ft-lb)

: Always replace after every disassembly.

For 3.5LE Grade

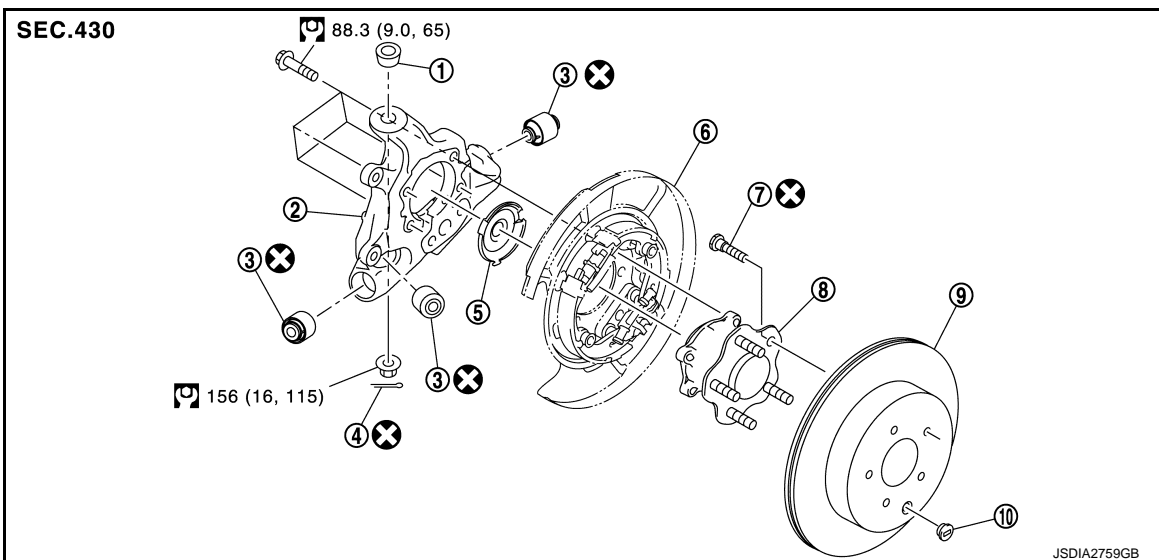

- | | | |
|---------------|-----------------|--------------------------------|
| 1. Ball seat | 2. Axle housing | 3. Bushing |
| 4. Cotter pin | 5. Hub cap | 6. Parking brake shoe assembly |

REAR WHEEL HUB AND HOUSING

< REMOVAL AND INSTALLATION >

7. Hub bolt
8. Wheel hub assembly (Bearing-integrated type)
9. Disc rotor
10. Plug

: N-m (kg-m, ft-lb)

: Always replace after every disassembly.

Removal and Installation

INFOID:000000009650476

REMOVAL

1. Remove tires with power tool. Refer to [WT-46, "Exploded View"](#).
2. Remove wheel sensor. Refer to [BRC-120, "REAR WHEEL SENSOR : Removal and Installation"](#).
3. Remove caliper assembly. Hang caliper assembly in a place where it will not interfere with work. Refer to [BR-47, "BRAKE CALIPER ASSEMBLY : Removal and Installation"](#).

CAUTION:

Never depress brake pedal while brake caliper is removed.

4. Remove disc rotor. If disc rotor cannot be removed, remove as follows.

CAUTION:

- Parking brake completely in the released position.
- Put matching marks (A) on the wheel hub assembly and the disc rotor before removing the disc rotor.
- Never drop disc rotor.

- a. Fix the disc rotor with wheel nuts and remove the adjusting hole plug.

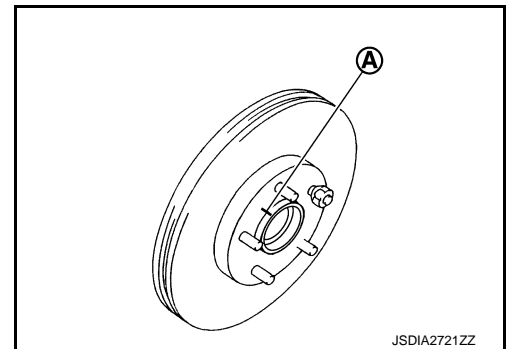

- b. Using suitable tool, rotate adjuster (1) in the direction (B) to retract and loosen brake shoe.

5. Remove wheel hub assembly.

6. Remove parking brake and rear cable from back plate.
 - Parking brake: Refer to [PB-8, "Removal and Installation"](#).
 - Rear cable: Refer to [PB-6, "Removal and Installation"](#).

7. Remove radius rod from axle housing. Refer to [RSU-13, "Exploded View"](#).

8. Remove rear lower link and coil spring. Refer to [RSU-8, "Removal and Installation"](#).

9. Set suitable jack under axle housing.

CAUTION:

- At this step, the jack must be set only for supporting the removal procedure. For details on jacking up the vehicle, refer to [GI-29, "Garage Jack and Safety Stand and 2-Pole Lift"](#).
- Never damage the axle housing with a jack.
- Check the stable condition when using a jack.

10. Remove front lower link from shock absorber with power tool. Refer to [RSU-10, "Exploded View"](#).

11. Remove front lower link from axle housing. Refer to [RSU-15, "Exploded View"](#).

12. Remove cotter pin, then remove suspension arm mounting nut.

13. Separate suspension arm from axle housing, using ball joint remover (commercial service tool), and then remove axle housing.

CAUTION:

- Never damage ball joint boot.
- Temporarily tighten nuts to prevent damage to threads and to prevent the ball joint remover from coming off.

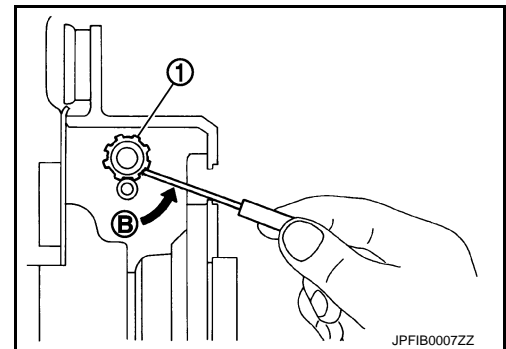

REAR WHEEL HUB AND HOUSING

< REMOVAL AND INSTALLATION >

14. Remove axle housing.
15. Remove hub cap.
16. Remove hub bolts (1) from wheel hub assembly, using the ball joint remover (A) (commercial service tool).

CAUTION:

- Remove hub bolt only when necessary.
- Never hammer the hub bolt to avoid impact to the wheel hub assembly.
- Pull out the hub bolt in a direction perpendicular to the wheel hub assembly.

17. Perform inspection after removal. Refer to [RAX-7, "Inspection"](#).

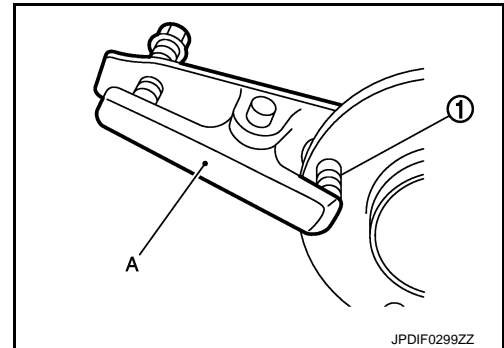

INSTALLATION

Note the following, and install in the reverse order of removal.

- Place a washer (A) as shown in the figure to install the hub bolts (1) by using the tightening force of the nut (B).

CAUTION:

- Check that there is no clearance between wheel hub assembly and hub bolt.
- Never reuse hub bolt.
- Align the matching marks that have been made during removal when reusing the disc rotor.
- Perform the final tightening of each of parts under unladen conditions, which were removed when removing suspension component.
- Never reuse cotter pin and bushing.
- Perform inspection after installation. Refer to [RAX-7, "Inspection"](#).

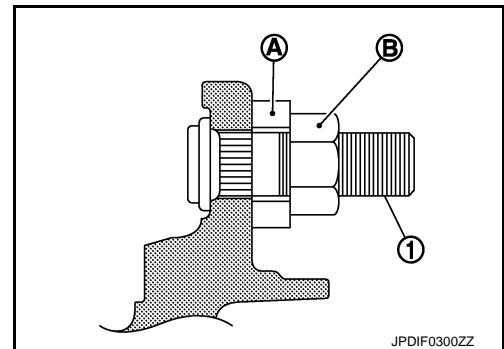

Inspection

INFOID:000000009650477

INSPECTION AFTER REMOVAL

Check the wheel hub assembly for wear, cracks, and damage. Replace if necessary.

INSPECTION AFTER INSTALLATION

1. Check wheel sensor harness for proper connection. [BRC-120, "REAR WHEEL SENSOR : Exploded View"](#).
2. Adjust parking brake operation (stroke). Refer to [PB-3, "Inspection and Adjustment"](#).
3. Check wheel alignment. Refer to [RSU-6, "Inspection"](#).
4. Adjust neutral position of steering angle sensor. Refer to [BRC-49, "Work Procedure"](#).

SERVICE DATA AND SPECIFICATIONS (SDS)

< SERVICE DATA AND SPECIFICATIONS (SDS)

SERVICE DATA AND SPECIFICATIONS (SDS)

SERVICE DATA AND SPECIFICATIONS (SDS)

Wheel Bearing

INFOID:000000009650478

Item	Standard
Axial end play	0.05 mm (0.002 in) or less