

SECTION **IP**
INSTRUMENT PANEL

A
B
C
D
E
F
G
H
I
IP
K
L
M
N
O
P

CONTENTS

PRECAUTION	2	SQUEAK AND RATTLE TROUBLE DIAG- NOSES	6
PRECAUTIONS	2	Work Flow	6
Precaution for Supplemental Restraint System (SRS) "AIR BAG" and "SEAT BELT PRE-TEN- SIONER"	2	Inspection Procedure	8
Precaution for Procedure without Cowl Top Cover.....	2	Diagnostic Worksheet	10
Precautions for Removing Battery Terminal	3	REMOVAL AND INSTALLATION	12
Service	3	INSTRUMENT PANEL ASSEMBLY	12
PREPARATION	4	Exploded View	12
PREPARATION	4	Removal and Installation	14
Special Service Tools	4	CENTER CONSOLE ASSEMBLY	27
Commercial Service Tools	4	Exploded View	27
CLIP LIST	5	Removal and Installation	28
Clip List	5	Disassembly and Assembly	29
SYMPTOM DIAGNOSIS	6	REAR CONSOLE ASSEMBLY	32
		Exploded View	32
		Removal and Installation	32
		Disassembly and Assembly	33

PRECAUTIONS

< PRECAUTION >

PRECAUTION

PRECAUTIONS

Precaution for Supplemental Restraint System (SRS) "AIR BAG" and "SEAT BELT PRE-TENSIONER"

INFOID:000000011323514

The Supplemental Restraint System such as "AIR BAG" and "SEAT BELT PRE-TENSIONER", used along with a front seat belt, helps to reduce the risk or severity of injury to the driver and front passenger for certain types of collision. This system includes seat belt switch inputs and dual stage front air bag modules. The SRS system uses the seat belt switches to determine the front air bag deployment, and may only deploy one front air bag, depending on the severity of a collision and whether the front occupants are belted or unbelted. Information necessary to service the system safely is included in the "SRS AIR BAG" and "SEAT BELT" of this Service Manual.

WARNING:

Always observe the following items for preventing accidental activation.

- To avoid rendering the SRS inoperative, which could increase the risk of personal injury or death in the event of a collision that would result in air bag inflation, all maintenance must be performed by an authorized NISSAN/INFINITI dealer.
- Improper maintenance, including incorrect removal and installation of the SRS, can lead to personal injury caused by unintentional activation of the system. For removal of Spiral Cable and Air Bag Module, see "SRS AIR BAG".
- Never use electrical test equipment on any circuit related to the SRS unless instructed to in this Service Manual. SRS wiring harnesses can be identified by yellow and/or orange harnesses or harness connectors.

PRECAUTIONS WHEN USING POWER TOOLS (AIR OR ELECTRIC) AND HAMMERS

WARNING:

Always observe the following items for preventing accidental activation.

- When working near the Air Bag Diagnosis Sensor Unit or other Air Bag System sensors with the ignition ON or engine running, never use air or electric power tools or strike near the sensor(s) with a hammer. Heavy vibration could activate the sensor(s) and deploy the air bag(s), possibly causing serious injury.
- When using air or electric power tools or hammers, always switch the ignition OFF, disconnect the battery, and wait at least 3 minutes before performing any service.

Precaution for Procedure without Cowl Top Cover

INFOID:000000011323515

When performing the procedure after removing cowl top cover, cover the lower end of windshield with urethane, etc to prevent damage to windshield.

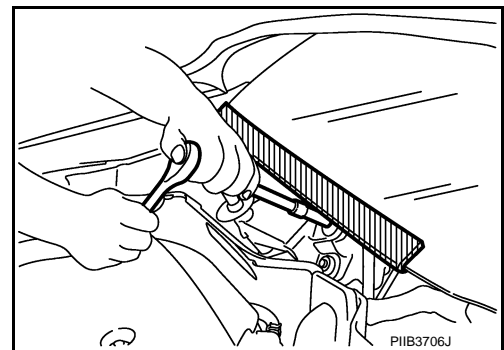

PRECAUTIONS

< PRECAUTION >

Precautions for Removing Battery Terminal

INFOID:000000011323516

- When removing the 12V battery terminal, turn OFF the ignition switch and wait at least 30 seconds.

NOTE:

ECU may be active for several tens of seconds after the ignition switch is turned OFF. If the battery terminal is removed before ECU stops, then a DTC detection error or ECU data corruption may occur.

- For vehicles with the 2-batteries, be sure to connect the main battery and the sub battery before turning ON the ignition switch.

NOTE:

If the ignition switch is turned ON with any one of the terminals of main battery and sub battery disconnected, then DTC may be detected.

- After installing the 12V battery, always check "Self Diagnosis Result" of all ECUs and erase DTC.

NOTE:

The removal of 12V battery may cause a DTC detection error.

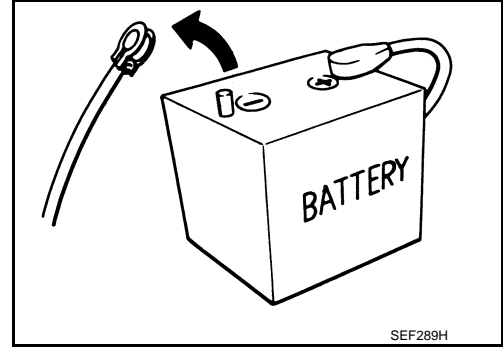

Service

INFOID:000000011323517

- Disconnect battery negative terminal in advance.
- Disconnect air bag system line in advance.
- Never tamper with or force air bag lid open, as this may adversely affect air bag performance.
- Be careful not to scratch pad and other parts.
- When removing or disassembling any part, be careful not to damage or deform it. Protect parts, that may get in the way with a shop cloth.
- When removing parts with a screwdriver or other tool, cover the tool surface with vinyl tape to protect parts.
- Keep removed parts protected with a shop cloth.
- If a clip is deformed or damaged, replace it.
- If an un reusable part is removed, replace it with a new one.
- Tighten bolts and nuts firmly to the specified torque.
- After reassembly is complete, check that each part functions correctly.
- Remove stains via the following procedure.

Water-soluble stains:

Dip a soft cloth in warm water, and then squeeze it tightly. After wiping off the stain, wipe with a soft dry cloth.

Oil stain:

Dissolve a synthetic detergent in warm water (density of 2 to 3%), dip the cloth, then wipe off the stain with the cloth. Next, dip the cloth in fresh water and squeeze it tightly. Then wipe off the detergent completely. Then wipe the area with a soft dry cloth.

- Never use any organic solvent, such as thinner or benzine.

A
B
C
D
E
F
G
H
I
IP
K
L
M
N
O
P

PREPARATION

< PREPARATION >

PREPARATION

PREPARATION

Special Service Tools

INFOID:000000011323518

The actual shapes of Kent-Moore tools may differ from those of special service tools illustrated here.

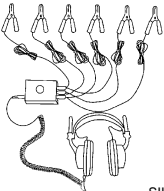
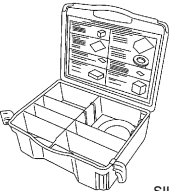
Tool number (Kent-Moore No.) Tool name	Description
(J-39570) Chassis ear  SIIA0993E	Locates the noise
(J-50397) NISSAN Squeak and Rattle Kit  SIIA0994E	Repairs the cause of noise

Commercial Service Tools

INFOID:000000011323519

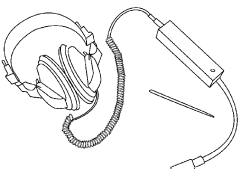
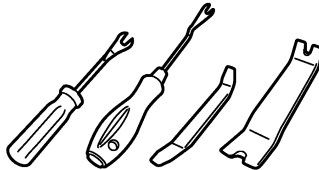
Tool name	Description
Engine ear  SIIA0995E	Locates the noise
Remover tool  JMKIA3050ZZ	Removes clips, pawls and metal clips

CLIP LIST

< PREPARATION >

CLIP LIST

Clip List

INFOID:000000011323520

Shapes	Removal & Installation	Shapes	Removal & Installation
	<p>Removal: Remove by bending up with flat-bladed screwdrivers or clip remover.</p>	<p>Clip A Clip B</p>	<p>Removal:</p> <p>Finisher Clip A Flat-bladed screwdriver Clip B</p>
	<p>Removal: Remove with a clip remover.</p>	<p>Clip A Clip B (Grommet)</p>	<p>Removal:</p> <p>Flat-bladed screwdriver Finisher Body panel Clip A Clip B (Grommet)</p>
	<p>Removal: Push center pin to catching position. (Do not remove center pin by hitting it.)</p> <p>Installation:</p>		<p>Removal: Holder portion of clip must be spread out to remove rod.</p>
	<p>Removal: Remove by bending up with flat-bladed screwdrivers or clip remover.</p> <p>Clip Finisher</p>		<p>Removal:</p> <ol style="list-style-type: none"> Screw out with a Phillips screwdriver. Remove female portion with flat-bladed screwdriver.
	<p>Removal:</p>		<p>Removal:</p> <p>Rotate 45° to remove.</p> <p>Installation:</p>
	<p>Removal:</p>		<p>Removal:</p>

JMJIA3734GB

A
B
C
D
E
F
G
H
I
IP
K
L
M
N
O
P

SQUEAK AND RATTLE TROUBLE DIAGNOSES

< SYMPTOM DIAGNOSIS >

SYMPTOM DIAGNOSIS

SQUEAK AND RATTLE TROUBLE DIAGNOSES

Work Flow

INFOID:000000011323521

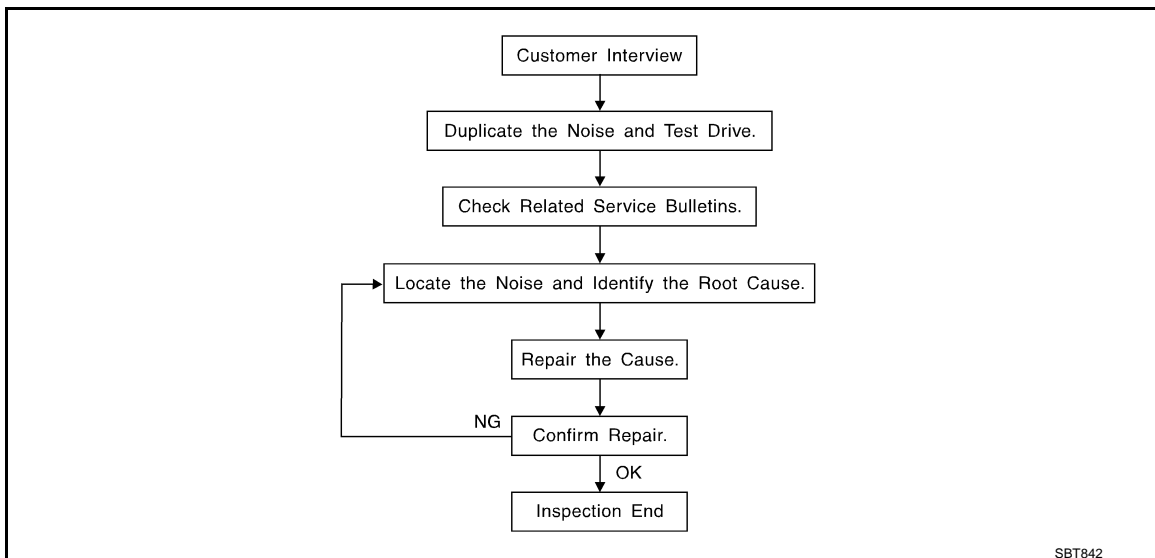

CUSTOMER INTERVIEW

Interview the customer if possible, to determine the conditions that exist when the noise occurs. Use the Diagnostic Worksheet during the interview to document the facts and conditions when the noise occurs and any customer comments. Refer to [IP-10, "Diagnostic Worksheet"](#). This information is necessary to duplicate the conditions that exist when the noise occurs.

- The customer may not be able to provide a detailed description or the location of the noise. Attempt to obtain all the facts and conditions that exist when the noise occurs (or does not occur).
- If there is more than one noise in the vehicle, perform a diagnosis and repair the noise that the customer is concerned about. This can be accomplished by performing a test drive with the customer.
- After identifying the type of noise, isolate the noise in terms of its characteristics. The noise characteristics are provided so that the customer, service adviser, and technician use the same language when describing the noise.
- Squeak – (Like tennis shoes on a clean floor)
Squeak characteristics include the light contact / fast movement / brought on by road conditions / hard surfaces = high-pitched noise / softer surfaces = low-pitched noises / edge to surface = chirping
- Creak – (Like walking on an old wooden floor)
Creak characteristics include firm contact / slow movement/twisting with a rotational movement / pitch dependent on materials / often brought on by activity.
- Rattle – (Like shaking a baby rattle)
Rattle characteristics include fast repeated contact / vibration or similar movement / loose parts/missing clip or fastener / incorrect clearance.
- Knock – (Like a knock on a door)
Knock characteristics include hollow sounds / sometimes repeating / often brought on by driver action.
- Tick – (Like a clock second hand)
Tick characteristics include gentle contacting of light materials / loose components / can be caused by driver action or road conditions.
- Thump – (Heavy, muffled knock noise)
Thump characteristics include softer knock / dull sounds often brought on by activity.
- Buzz – (Like a bumblebee)
Buzz characteristics include high frequency rattle / firm contact.
- Often the degree of acceptable noise level varies depending upon the person. A noise that a technician may judge as acceptable may be very irritating to a customer.
- Weather conditions, especially humidity and temperature, may have a great effect on noise level.

DUPLICATE THE NOISE AND TEST DRIVE

SQUEAK AND RATTLE TROUBLE DIAGNOSES

< SYMPTOM DIAGNOSIS >

If possible, drive the vehicle with the customer until the noise is duplicated. Note any additional information on the Diagnostic Worksheet regarding the conditions or location of the noise. This information can be used to duplicate the same conditions when the repair is reconfirmed.

If the noise can be duplicated easily during the test drive, to help identify the source of the noise, try to duplicate the noise with the vehicle stopped by doing one or all of the following items:

- 1) Close a door.
 - 2) Tap or push/pull around the area where the noise appears to be coming from.
 - 3) Rev the motor.
 - 4) Use a floor jack to recreate vehicle "twist".
 - 5) At idle, apply motor load (electrical load, half-clutch on M/T models, drive position on A/T models).
 - 6) Raise the vehicle on a hoist and hit a tire with a rubber hammer.
- Drive the vehicle and attempt to duplicate the conditions the customer states exist when the noise occurs.
 - If it is difficult to duplicate the noise, drive the vehicle slowly on an undulating or rough road to stress the vehicle body.

CHECK RELATED SERVICE BULLETINS

After verifying the customer concern or symptom, check ASIST for Technical Service Bulletins (TSBs) related to the concern or symptom.

If a TSB relates to the symptom, follow the procedure to repair the noise.

LOCATE THE NOISE AND IDENTIFY THE ROOT CAUSE

1. Narrow down the noise to a general area. To help pinpoint the source of the noise, use a listening tool (Chassis ear: J-39570, engine ear, and mechanics stethoscope).
2. Narrow down the noise to a more specific area and identify the cause of the noise by:
 - Removing the component(s) in the area that is / are suspected to be the cause of the noise. Do not use too much force when removing clips and fasteners, otherwise clips and fasteners can be broken or lost during the repair, resulting in the creation of new noise.
 - Tapping or pushing/pulling the component(s) that is / are suspected to be the cause of the noise. Do not tap or push/pull the component(s) with excessive force, otherwise the noise is eliminated only temporarily.
 - Feeling for a vibration by hand by touching the component(s) that is / are suspected to be the cause of the noise.
 - Placing a piece of paper between components that are suspected to be the cause of the noise.
 - Looking for loose components and contact marks.
Refer to [IP-8, "Inspection Procedure"](#).

REPAIR THE CAUSE

- If the cause is a loose component, tighten the component securely.
- If the cause is insufficient clearance between components:
 - Separate components by repositioning or loosening and retightening the components, if possible.
 - Insulate components with a suitable insulator such as urethane pads, foam blocks, felt cloth tape, or urethane tape. A NISSAN Squeak and Rattle Kit (J-50397) is available through the authorized NISSAN Parts Department.

CAUTION:

Never use excessive force as many components are constructed of plastic and may be damaged.

NOTE:

Always check with the Parts Department for the latest parts information.

The following materials are contained in the NISSAN Squeak and Rattle Kit (J-50397) are listed on the inside cover of the kit; and can each be ordered separately as needed.

URETHANE PADS [1.5 mm (0.059 in) thick]

Insulates connectors, harness, etc.

- 76268-9E005: 100 × 135 mm (3.937 × 5.315 in)
- 76884-71L01: 60 × 85 mm (2.362 × 3.346 in)
- 76884-71L02: 15 × 25 mm (0.591 × 0.984 in)

INSULATOR (Foam blocks)

Insulates components from contact. Can be used to fill space behind a panel.

- 73982-9E000: 45 mm (1.772 in) thick, 50 × 50 mm (1.969 × 1.969 in)
- 73982-50Y00: 10 mm (0.394 in) thick, 50 × 50 mm (1.969 × 1.969 in)

INSULATOR (Light foam block)

80845-71L00: 30 mm (1.181 in) thick, 30 × 50 mm (1.181 × 1.969 in)

FELT CLOTHTAPE

SQUEAK AND RATTLE TROUBLE DIAGNOSES

< SYMPTOM DIAGNOSIS >

Used to insulate where movement does not occur. Ideal for instrument panel applications.

- 68370-4B000: 15 × 25 mm (0.591 × 0.984 in) pad
- 68239-13E00: 5 mm (0.197 in) wide tape roll

The following materials, not found in the kit, can also be used to repair squeaks and rattles.

UHMW (TEFLON) TAPE

Insulates where slight movement is present. Ideal for instrument panel applications.

SILICONE GREASE

Used in place of UHMW tape that is visible or does not fit. Only lasts a few months.

SILICONE SPRAY

Used when grease cannot be applied.

DUCT TAPE

Used to eliminate movement.

CONFIRM THE REPAIR

After repair is complete, test drive the vehicle to confirm that the cause of noise is repaired by test driving the vehicle. Operate the vehicle under the same conditions as when the noise originally occurred. Refer to the notes on the Diagnostic Worksheet.

Inspection Procedure

INFOID:000000011323522

Refer to Table of Contents for specific component removal and installation information.

INSTRUMENT PANEL

Most incidents are caused by contact and movement between:

1. The cluster lid A and instrument panel
2. Acrylic lens and combination meter housing
3. Instrument panel to front pillar garnish
4. Instrument panel to windshield
5. Instrument panel mounting pins
6. Wiring harnesses behind the combination meter
7. A/C defroster duct and duct joint

These incidents can usually be located by tapping or moving the components to duplicate the noise or by pressing on the components while driving to stop the noise. Most of these incidents can be repaired by applying felt cloth tape or silicon spray (in hard to reach areas). Urethane pads can be used to insulate wiring harness.

CAUTION:

Never use silicone spray to isolate a squeak or rattle. If the area is saturated with silicone, the recheck of repair becomes impossible.

CENTER CONSOLE

Components to check include:

1. Shifter assembly cover to finisher
2. A/C control unit and cluster lid C
3. Wiring harnesses behind audio and A/C control unit

The instrument panel repair and isolation procedures also apply to the center console.

DOORS

Check the following items:

1. Finisher and inner panel making a slapping noise
2. Inside handle escutcheon connection to door finisher
3. Wiring harnesses tapping
4. Door striker out of alignment causing a popping noise on starts and stops

Tapping, moving the components, or pressing on them while driving to duplicate the conditions can isolate many of these incidents. The areas can usually be insulated with felt cloth tape or insulator foam blocks from the NISSAN Squeak and Rattle Kit (J-50397) to repair the noise.

TRUNK

Trunk noises are often caused by a loose jack or loose items put into the trunk by the customer.

In addition check for the following items:

SQUEAK AND RATTLE TROUBLE DIAGNOSES

< SYMPTOM DIAGNOSIS >

1. Trunk lid dumpers out of adjustment
2. Trunk lid striker out of adjustment
3. Trunk lid torsion bars knocking together
4. A loose license plate or bracket

Most of these incidents can be repaired by adjusting, securing, or insulating the item(s) or component(s) causing the noise.

SUNROOF/HEADLINING

Noises in the sunroof / headlining area can often be traced to one of the following items:

1. Sunroof lid, rail, linkage, or seals making a rattle or light knocking noise
2. Sunvisor shaft shaking in the holder
3. Front or rear windshield touching headlining and squeaking

Again, pressing on the components to stop the noise while duplicating the conditions can isolate most of these incidents. Repairs usually consist of insulating with felt cloth tape.

SEATS

When isolating seat noise it is important to note the position the seat is in and the load placed on the seat when the noise occurs. These conditions should be duplicated when verifying and isolating the cause of the noise.

Causes of seat noise include:

1. Headrest rods and holder
2. A squeak between the seat pad cushion and frame
3. The rear seatback lock and bracket

These noises can be isolated by moving or pressing on the suspected components while duplicating the conditions under which the noise occurs. Most of these incidents can be repaired by repositioning the component or applying urethane tape to the contact area.

UNDERHOOD

Some interior noise may be caused by components under the hood or on the motor wall. The noise is then transmitted into the passenger compartment.

Causes of transmitted underhood noise include:

1. Any component mounted to the motor wall
2. Components that pass through the motor wall
3. Motor wall mounts and connectors
4. Loose radiator mounting pins
5. Hood bumpers out of adjustment
6. Hood striker out of adjustment

These noises can be difficult to isolate since they cannot be reached from the interior of the vehicle. The best method is to secure, move, or insulate one component at a time and test drive the vehicle. Also, motor RPM or load can be changed to isolate the noise. Repairs can usually be made by moving, adjusting, securing, or insulating the component causing the noise.

A
B
C
D
E
F
G
H
I
IP
K
L
M
N
O
P

SQUEAK AND RATTLE TROUBLE DIAGNOSES

< SYMPTOM DIAGNOSIS >

Diagnostic Worksheet

INFOID:000000011323523



SQUEAK & RATTLE DIAGNOSTIC WORKSHEET

Dear Nissan Customer:

We are concerned about your satisfaction with your Nissan vehicle. Repairing a squeak or rattle sometimes can be very difficult. To help us fix your Nissan right the first time, please take a moment to note the area of the vehicle where the squeak or rattle occurs and under what conditions. You may be asked to take a test drive with a service advisor or technician to ensure we confirm the noise you are hearing.

I. WHERE DOES THE NOISE COME FROM? (circle the area of the vehicle)

The illustrations are for reference only, and may not reflect the actual configuration of your vehicle.

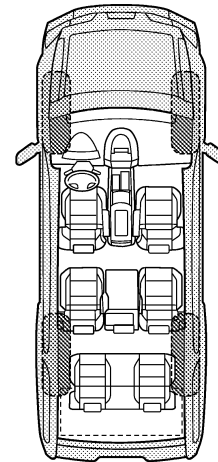
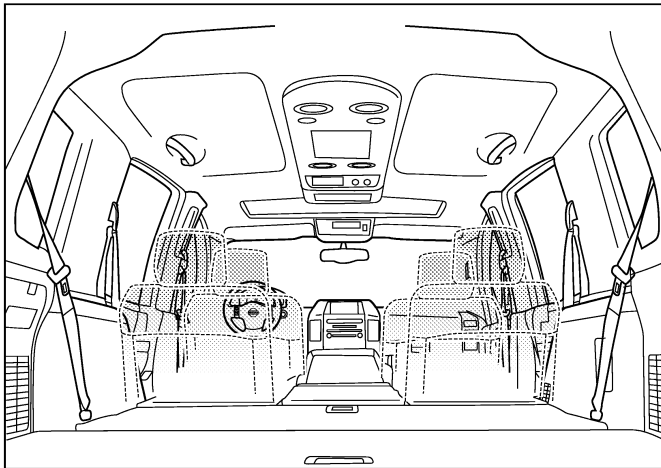
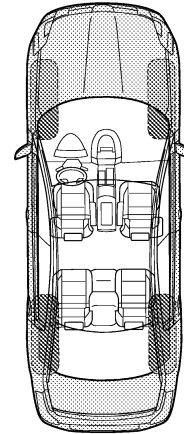
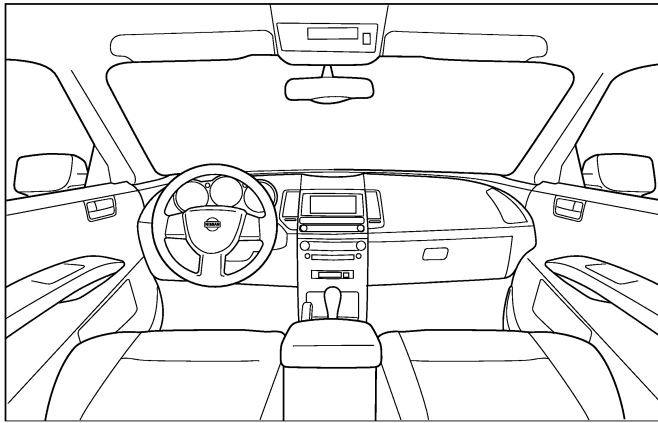

Continue to page 2 of the worksheet and briefly describe the location of the noise or rattle. In addition, please indicate the conditions which are present when the noise occurs.

PIIB8740E

SQUEAK AND RATTLE TROUBLE DIAGNOSES

< SYMPTOM DIAGNOSIS >

SQUEAK & RATTLE DIAGNOSTIC WORKSHEET - page 2

Briefly describe the location where the noise occurs:

II. WHEN DOES IT OCCUR? (please check the boxes that apply)

- | | |
|---|--|
| <input type="checkbox"/> anytime | <input type="checkbox"/> after sitting out in the rain |
| <input type="checkbox"/> 1st time in the morning | <input type="checkbox"/> when it is raining or wet |
| <input type="checkbox"/> only when it is cold outside | <input type="checkbox"/> dry or dusty conditions |
| <input type="checkbox"/> only when it is hot outside | <input type="checkbox"/> other: |

III. WHEN DRIVING:

- through driveways
- over rough roads
- over speed bumps
- only about ____ mph
- on acceleration
- coming to a stop
- on turns: left, right or either (circle)
- with passengers or cargo
- other: _____
- after driving ____ miles or ____ minutes

IV. WHAT TYPE OF NOISE

- squeak (like tennis shoes on a clean floor)
- creak (like walking on an old wooden floor)
- rattle (like shaking a baby rattle)
- knock (like a knock at the door)
- tick (like a clock second hand)
- thump (heavy, muffled knock noise)
- buzz (like a bumble bee)

TO BE COMPLETED BY DEALERSHIP PERSONNEL

Test Drive Notes:

	YES	NO	Initials of person performing
Vehicle test driven with customer	<input type="checkbox"/>	<input type="checkbox"/>	_____
- Noise verified on test drive	<input type="checkbox"/>	<input type="checkbox"/>	_____
- Noise source located and repaired	<input type="checkbox"/>	<input type="checkbox"/>	_____
- Follow up test drive performed to confirm repair	<input type="checkbox"/>	<input type="checkbox"/>	_____

VIN: _____ Customer Name: _____
W.O.# _____ Date: _____

This form must be attached to Work Order

PIIB8742E

A
B
C
D
E
F
G
H
I
IP
K
L
M
N
O
P

INSTRUMENT PANEL ASSEMBLY

< REMOVAL AND INSTALLATION >

REMOVAL AND INSTALLATION

INSTRUMENT PANEL ASSEMBLY

Exploded View

INFOID:000000011323524

INSTRUMENT PANEL ASSEMBLY

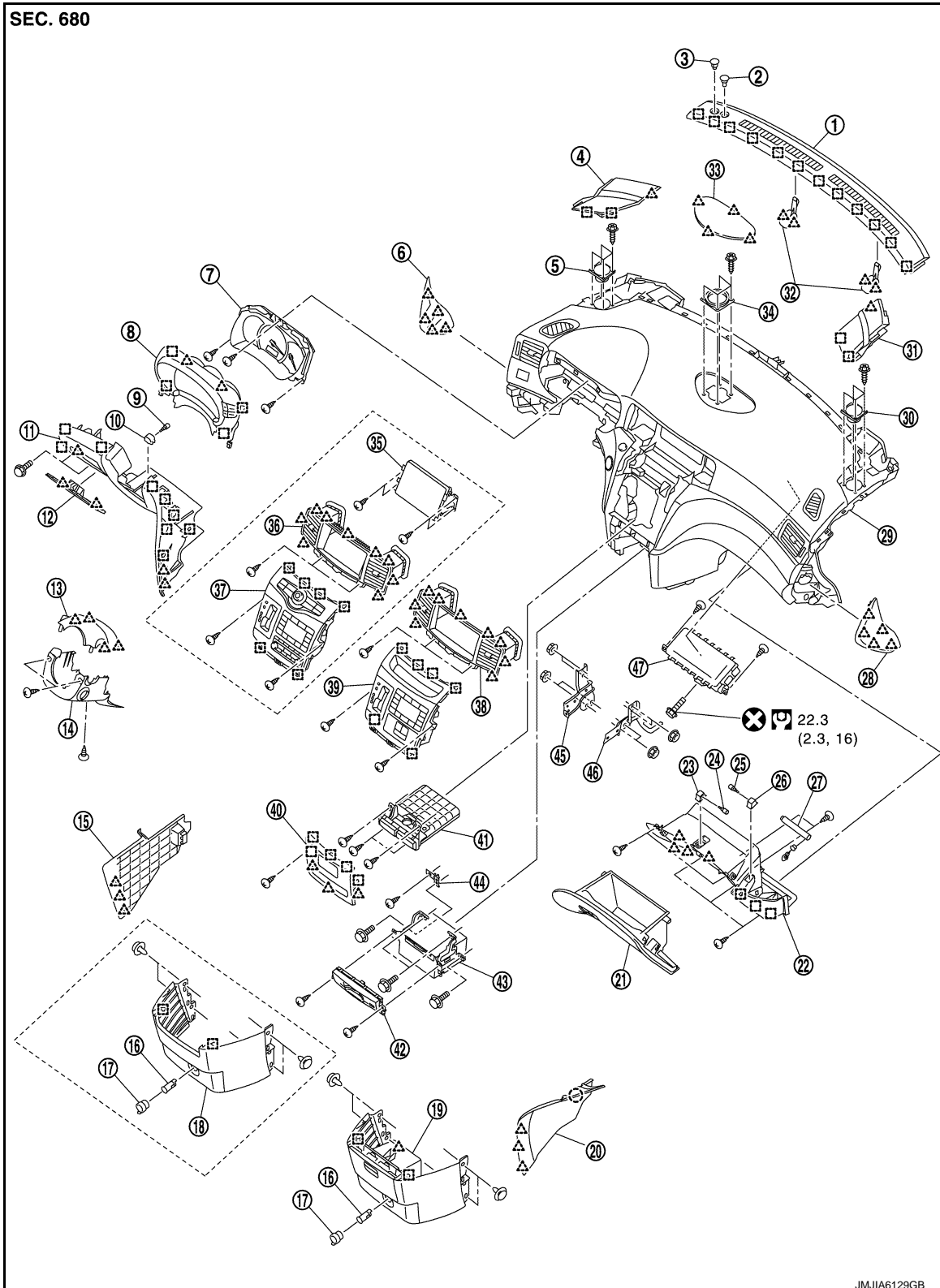

INSTRUMENT PANEL ASSEMBLY

< REMOVAL AND INSTALLATION >

- | | | |
|--|------------------------------------|---|
| 1. Instrument upper garnish | 2. Sunload sensor | 3. Optical sensor |
| 4. Speaker grille LH | 5. Front squawker LH | 6. Instrument side finisher LH |
| 7. Combination meter | 8. Cluster lid A | 9. Socket and bulb |
| 10. Foot well lamp LH | 11. Instrument lower panel LH | 12. Fuse block lid |
| 13. Steering column upper cover | 14. Steering column lower cover | 15. Instrument lower cover LH |
| 16. Socket inner case | 17. Socket knob | 18. Instrument lower cover center (With NAVI) |
| 19. Instrument lower cover center (Without NAVI) | 20. Instrument lower cover RH | 21. Glove box assembly |
| 22. Instrument lower panel RH | 23. Glove box lamp | 24. Socket and bulb |
| 25. Socket and bulb | 26. Foot well lamp RH | 27. Glove box damper |
| 28. Instrument side finisher RH | 29. Instrument panel assembly | 30. Front squawker RH |
| 31. Speaker grille RH | 32. Instrument bracket | 33. Center speaker grille |
| 34. Center squawker | 35. Front display unit (With NAVI) | 36. Cluster lid D (With NAVI) |
| 37. Cluster lid C (With NAVI) | 38. Cluster lid D (Without NAVI) | 39. Cluster lid C (Without NAVI) |
| 40. Instrument lower panel center | 41. Cup holder assembly | 42. Disc eject switch (With NAVI) |
| 43. AV C/U (With NAVI) | 44. Steering member lower bracket | 45. Instrument stay LH |
| 46. Instrument stay RH | 47. Front passenger air bag module | |

 : Clip

 : Pawl

 : Metal clip

 : Always replace after every disassembly.

 : N·m (kg·m, ft·lb)

INSTRUMENT FINISHER

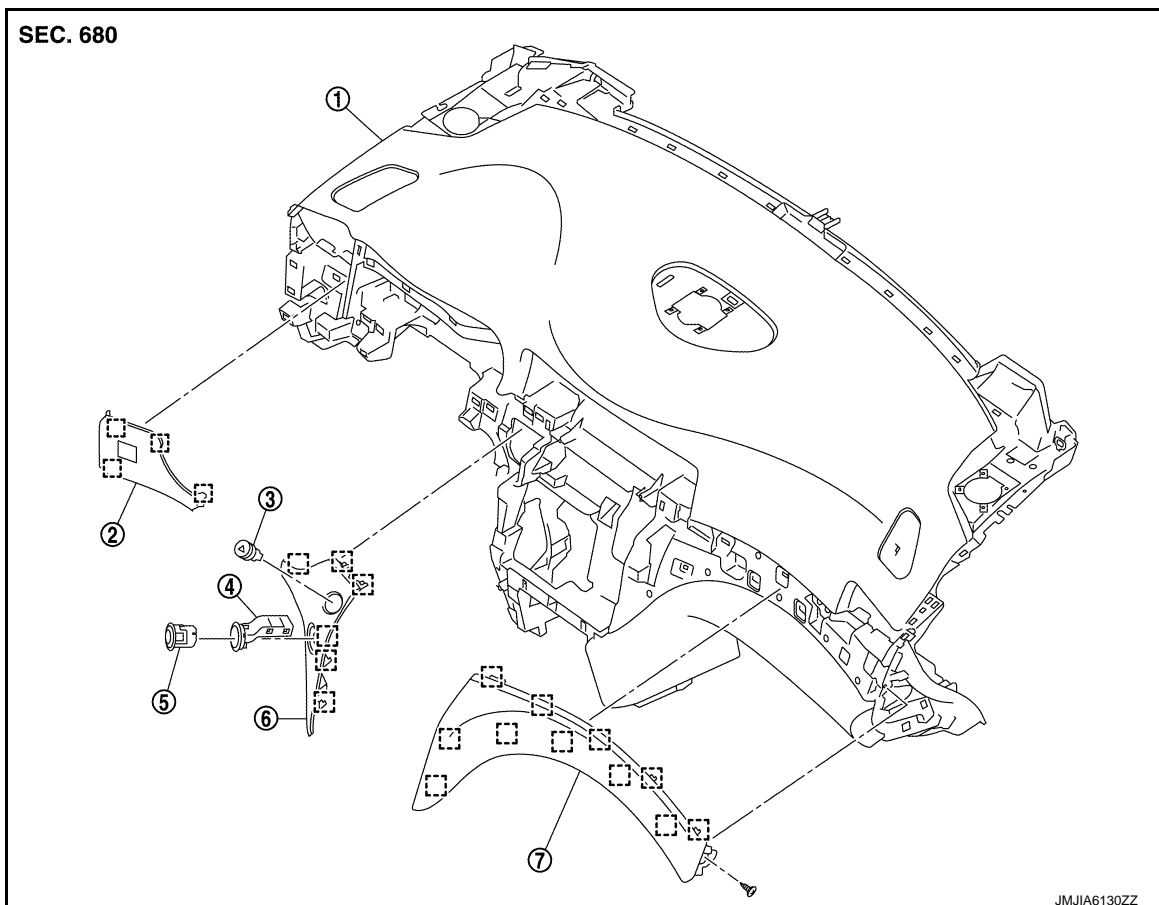

A
B
C
D
E
F
G
H
I
IP
K
L
M
N
O
P

INSTRUMENT PANEL ASSEMBLY

< REMOVAL AND INSTALLATION >

- | | | |
|------------------------------|--------------------------|--------------------------|
| 1. Instrument panel assembly | 2. Instrument finisher B | 3. Hazard switch |
| 4. NATS antenna amp. | 5. Ignition switch | 6. Instrument finisher A |
| 7. Instrument finisher C | | |
- [] : Metal clip

Removal and Installation

INFOID:000000011323525

WORK STEP

PARTS	INSTRUMENT PANEL ASSEMBLY	COMBI- NATION METER	AV C/U	FRONT DISPLAY	INSTRU- MENT FINISH- ER A	INSTRU- MENT FINISH- ER B	INSTRU- MENT FINISH- ER C
Front body side welt LH	[1]	[1]		[1]	[1]	[1]	
Instrument side finisher LH	[2]	[2]		[2]	[2]	[2]	
Front pillar garnish LH	[3]						
Front pillar lower garnish LH	[4]						
Speaker grille LH	[5]						
Front squawker LH	[6]						
Instrument lower cover LH	[7]	[3]	[1]	[3]	[3]	[3]	
Instrument lower cover RH	[8]	[4]	[2]	[4]	[4]	[4]	
Instrument lower cover center	[9]	[5]	[3]	[5]	[5]	[5]	
Instrument lower panel LH	[10]			[6]	[6]	[6]	
Instrument finisher A	[11]	[6]		[7]	[7]		
Instrument finisher B	[12]	[7]				[7]	
Driver air bag module	[13]						
Steering wheel	[14]						
Steering column covers	[15]						
Spiral cable	[16]						
Combination switch	[17]						
Cluster lid A	[18]	[8]					
Combination meter	[19]	[9]					
BCM	[20]						
Optical sensor	[21]						
Sunload sensor	[22]						
Front body side welt RH	[23]						
Instrument side finisher RH	[24]						[1]
Front pillar garnish RH	[25]						
Front pillar lower garnish RH	[26]						
Speaker grille RH	[27]						
Front Squawker RH	[28]						
Disk eject switch	[29]		[4]				
Instrument lower panel center	[30]			[8]			
AV C/U	[31]		[5]				
Instrument finisher C	[32]			[9]			[2]
Selector lever	[33]			[10]			
Cluster lid C	[34]			[11]			

INSTRUMENT PANEL ASSEMBLY

< REMOVAL AND INSTALLATION >

Cluster lid D	[35]			[12]			
Front display unit	[36]			[13]			
Center speaker grille	[37]						
Center squawker	[38]						
Glove box lid	[39]						
Instrument lower panel RH	[40]						
Passenger air bag module connecting harness connector	[41]						
Passenger air bag module mounting bolts and screws	[42]						
Cup holder assembly	[43]						
Instrument panel assembly	[44]						
Instrument upper garnish	[45]						

[]: Number indicates step in removal procedure.

WARNING:

Before servicing, turn ignition switch OFF, disconnect battery negative terminal and wait 3 minutes or more.

CAUTION:

When removing, always use a remover tool that is made of plastic.

REMOVAL

1. Remove front body side welt LH. Refer to [INT-23. "BODY SIDE WELT : Removal and Installation"](#).
2. Remove instrument side finisher LH.
 - a. Insert a remover tool (A) into lower space.
 - b. Pull the instrument side finisher LH crosswise, and then disengage the pawls

CAUTION:

Apply protective tape (B) on the part to protect it from damage.

 : Pawl

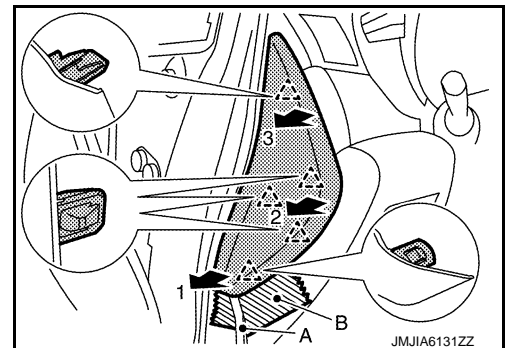

3. Remove front pillar garnish LH. Refer to [INT-21. "FRONT PILLAR GARNISH : Removal and Installation"](#).
4. Remove front pillar lower garnish LH. Refer to [INT-22. "FRONT PILLAR LOWER GARNISH : Removal and Installation"](#).
5. Remove speaker grille LH.
 - a. Pull up speaker grille LH, and then disengage pawl.
 - b. Pull back speaker grille LH, and then disengage metal clips.

 : Pawl

 : Metal clip

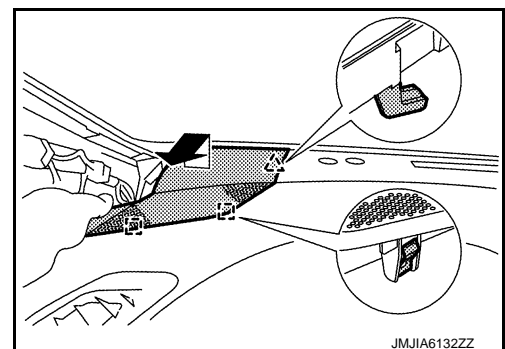

6. Remove front squawker LH. Refer to the following.
 - For Display audio: Refer to [AV-104. "Removal and Installation"](#).
 - For Base audio with separate display: Refer to [AV-242. "Removal and Installation"](#).

INSTRUMENT PANEL ASSEMBLY

< REMOVAL AND INSTALLATION >

- For Bose audio without navigation: Refer to [AV-396. "Removal and Installation"](#).
- For Bose audio with navigation: Refer to [AV-605. "Removal and Installation"](#).

7. Remove instrument lower cover LH.

- Insert a remover tool (A) between instrument lower cover LH, and instrument lower cover center to disengage pawls as shown in the figure.
- Pull back instrument lower cover LH.

CAUTION:

Apply protective tape (B) on the part to protect it from damage.

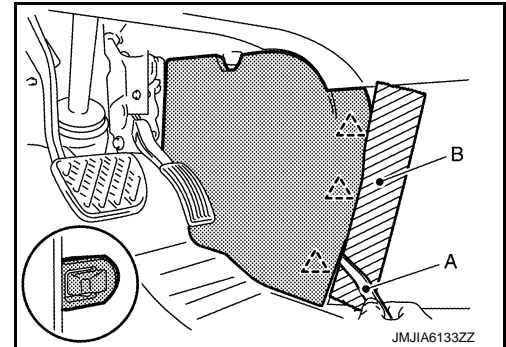
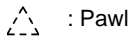

8. Remove instrument lower cover RH.

- Insert remover tool (A) between instrument lower cover RH, and instrument lower cover center to disengage the pawls as shown in the figure.
- Pull back instrument lower cover RH, and then disengage clip.

CAUTION:

Apply protective tape (B) on the part to protect it from damage.

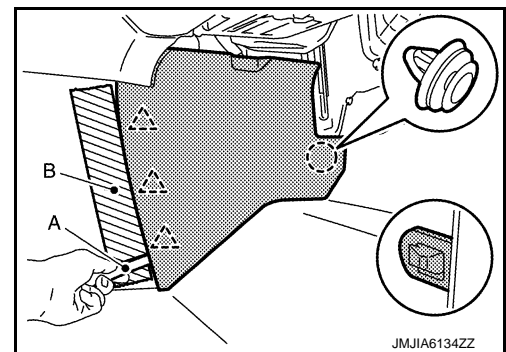
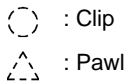

9. Remove instrument lower cover center.

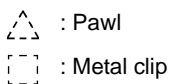
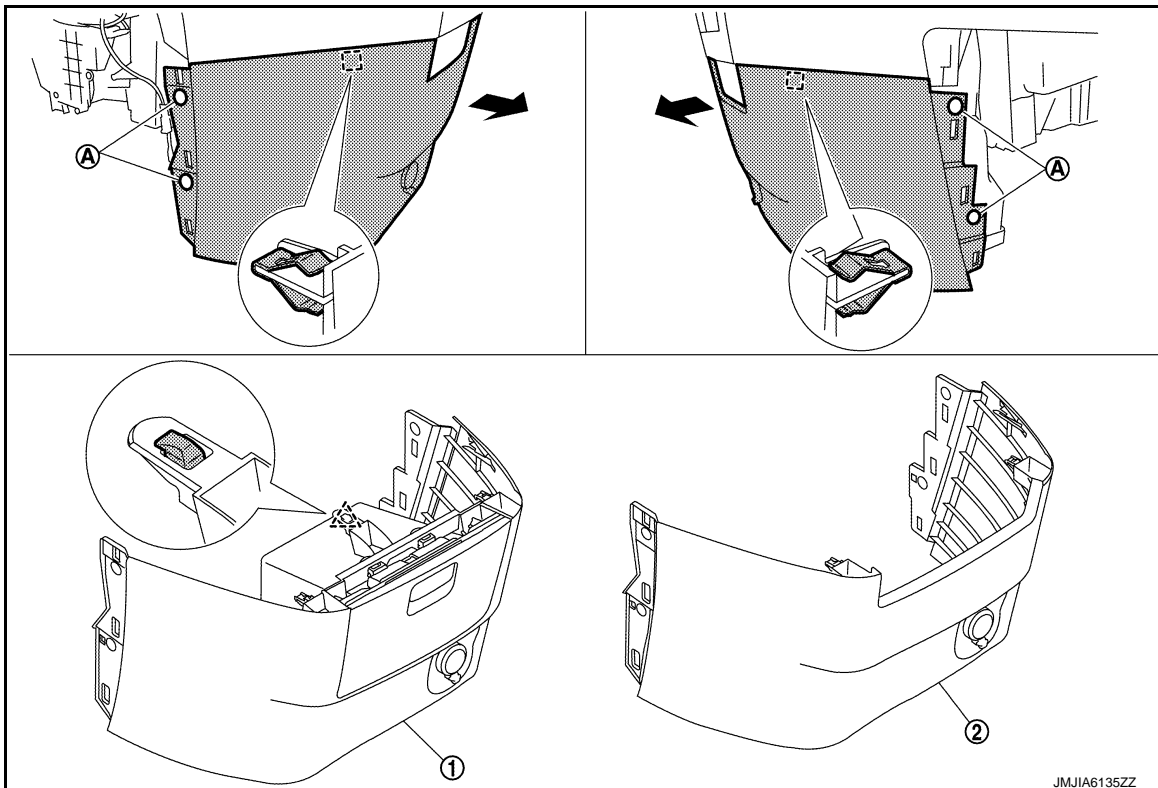

- Without NAVI

INSTRUMENT PANEL ASSEMBLY

< REMOVAL AND INSTALLATION >

- i. Remove clips (A).
- ii. Pull back instrument lower cover center (1), and then disengage pawl and metal clips.
- iii. Disconnect harness connector and remove harness clip.
- b. With NAVI
 - i. Remove clips (A).
 - ii. Pull back instrument lower cover center (2), and then disengage metal clips.
 - iii. Disconnect harness connector and remove harness clip.
10. Remove instrument lower panel LH.
 - a. Remove hood opener and fuel lid opener lever fixing bolts. Refer to [DLK-452, "HOOD LOCK : Removal and Installation"](#).
 - b. Pull back instrument lower panel LH, and then disengage pawls and metal clips.

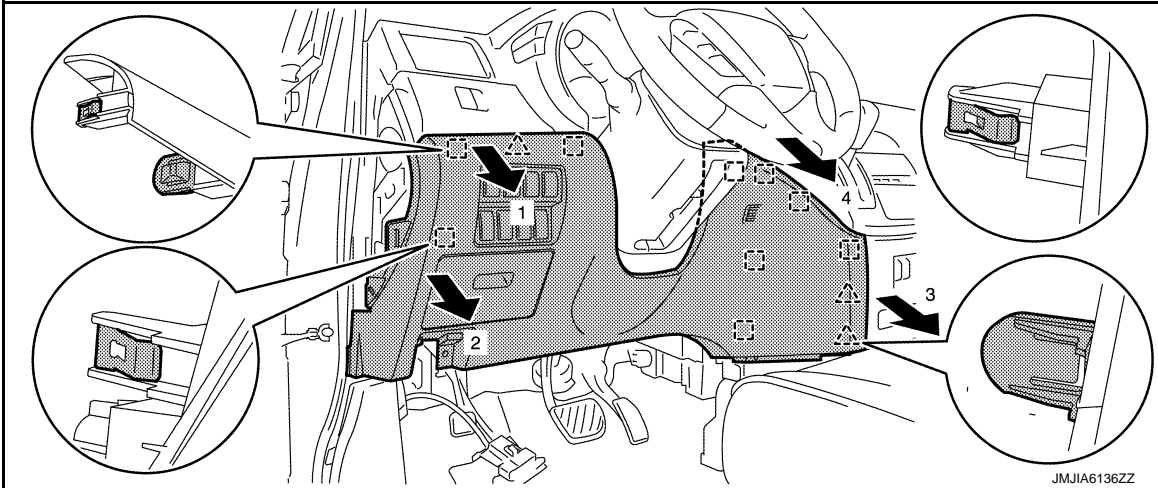

CAUTION:
Never pull instrument lower panel LH forcefully.

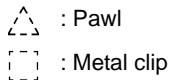

- c. Release data link connector (pawls) then remove it from instrument lower panel LH.
 - d. Disconnect harness connectors, aspirator duct and remove harness clip.
11. Remove instrument finisher A.
 - a. Pull back instrument finisher A, and then disengage metal clips.
 - b. Disconnect harness connectors.

CAUTION:
Never pull instrument finisher A forcefully.

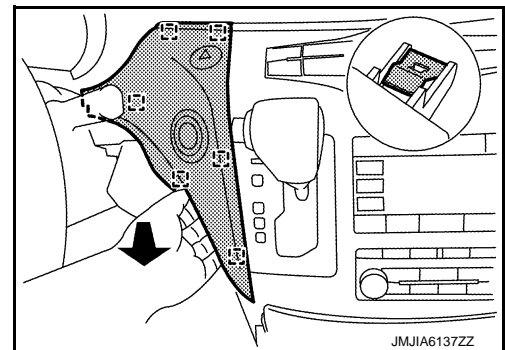
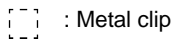

12. Remove instrument finisher B.

INSTRUMENT PANEL ASSEMBLY

< REMOVAL AND INSTALLATION >

- a. Lift up instrument finisher B lower right side, and then disengage metal clips.
- b. Pull back instrument finisher B upper right side, and then disengage metal clips.
- c. Pull back instrument finisher B left side, and then disengage metal clips.

 : Metal clip

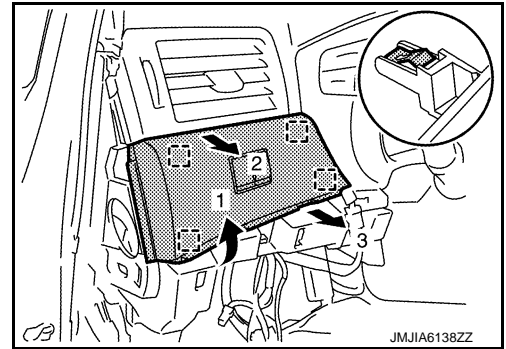

13. Remove driver air bag module. Refer to [SR-12, "Removal and Installation"](#).
14. Remove steering wheel assembly. Refer to [ST-12, "Removal and Installation"](#).
15. Remove steering column covers.
 - a. Remove steering column cover fixing screws (A).
 - b. Pull up steering column upper cover (1), and then remove steering column upper cover.
 - c. Pull down steering column lower cover (2), and then remove steering column lower cover.

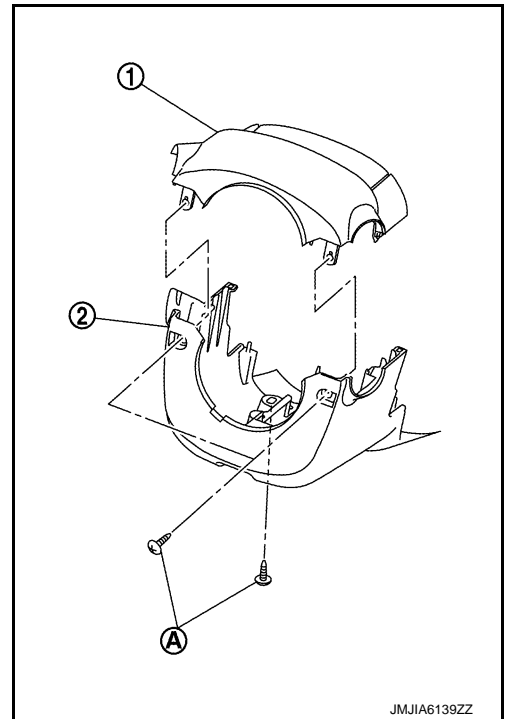

16. Remove spiral cable. Refer to [SR-15, "Removal and Installation"](#).
17. Remove combination switch. Refer to [BCS-99, "Removal and Installation"](#).
18. Remove cluster lid A.
 - a. Disconnect harness connectors (A).

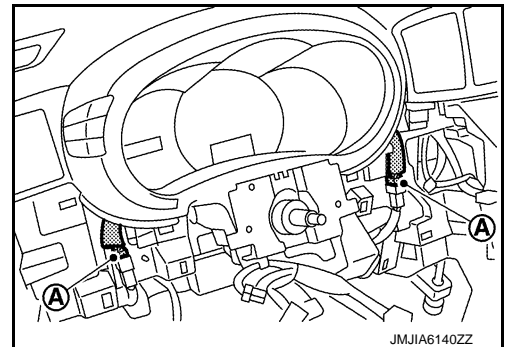

- b. Pull back cluster lid A right side, and then disengage the pawls and metal clips.

INSTRUMENT PANEL ASSEMBLY

< REMOVAL AND INSTALLATION >

- c. Pull back cluster lid A left side, and then disengage the pawls and metal clips.

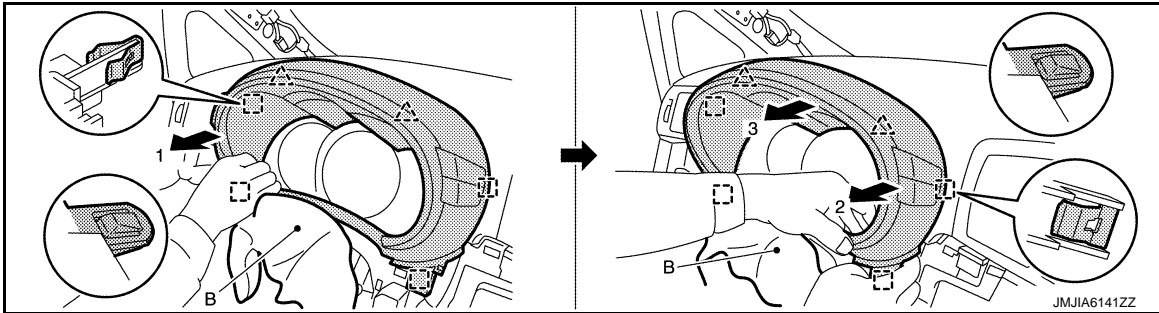

CAUTION:
Cover steering shaft with a shop cloth (B) to prevent it from being damaged.

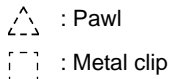

19. Remove combination meter. Refer to [MWI-90, "Exploded View"](#).
20. Remove BCM. Refer to [BCS-98, "Removal and Installation"](#).
21. Remove optical sensor. Refer to [EXL-108, "Removal and Installation"](#) (for Xenon type) or [EXL-218, "Removal and Installation"](#) (for Halogen type).
22. Remove sunload sensor. Refer to [HAC-147, "Removal and Installation"](#).
23. Remove front body side welt RH. Refer to [INT-23, "BODY SIDE WELT : Removal and Installation"](#).
24. Remove instrument side finisher RH.

- a. Insert a remover tool (A) into lower space.
- b. Pull the instrument side finisher RH crosswise, and then disengage the pawls

CAUTION:
Apply protective tape (B) on the part to protect it from damage.

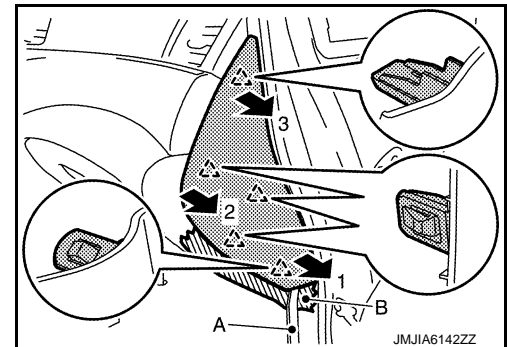
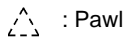

25. Remove front pillar garnish RH. Refer to [INT-21, "FRONT PILLAR GARNISH : Removal and Installation"](#).
26. Remove front pillar lower garnish RH. Refer to [INT-22, "FRONT PILLAR LOWER GARNISH : Removal and Installation"](#).
27. Remove speaker grille RH.

- a. Pull up speaker grille RH, and then disengage pawl.
- b. Pull back speaker grille RH, and then disengage metal clips.

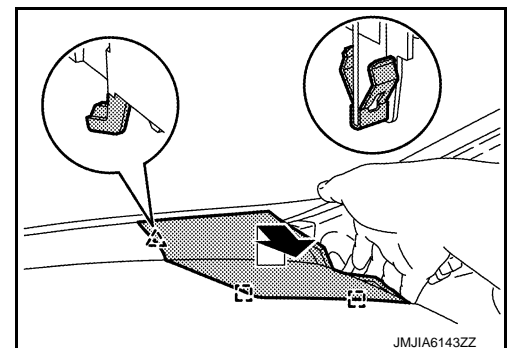
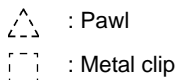

28. Remove front squawker RH. Refer to the following.
 - For Display audio: Refer to [AV-104, "Removal and Installation"](#).
 - For Base audio with separate display: Refer to [AV-242, "Removal and Installation"](#).
 - For Bose audio without navigation: Refer to [AV-396, "Removal and Installation"](#).
 - For Bose audio with navigation: Refer to [AV-605, "Removal and Installation"](#).

A
B
C
D
E
F
G
H
I
IP
K
L
M
N
O
P

INSTRUMENT PANEL ASSEMBLY

< REMOVAL AND INSTALLATION >

29. Remove disc eject switch. Refer to [AV-37, "Removal and Installation"](#) (for Base audio without separate disc) or [AV-102, "Removal and Installation"](#) (for Display audio).
30. Remove instrument lower panel center.
 - a. Remove fixing screw (A).
 - b. Pull back instrument lower panel center, and then disengage pawls and metal clips.
 - c. Disconnect harness connectors.

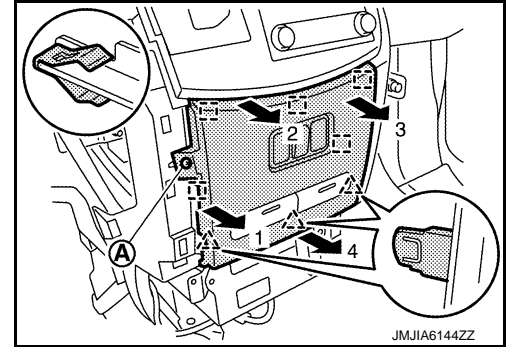
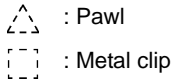

31. Remove AV C/U. Refer to [AV-37, "Removal and Installation"](#) (for Base audio without separate disc) or [AV-102, "Removal and Installation"](#) (for Display audio).
32. Remove instrument finisher C.
 - a. Remove fixing screw (A).

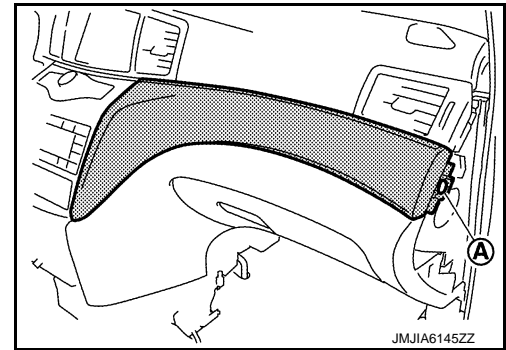

- b. Insert a remover tool (A) into instrument finisher C right side, and then disengage metal clips as shown in the figure.

CAUTION:

- Remove metal clips slowly so that they are not damaged.
- Never pull instrument finisher C forcefully.

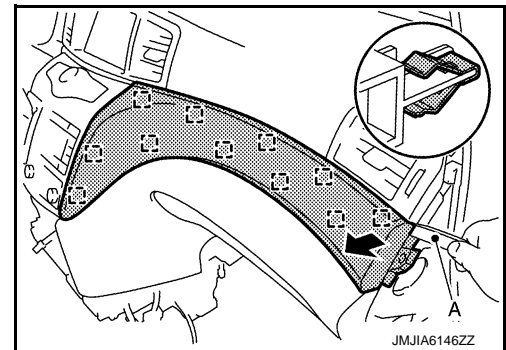

- c. Insert a remover tool (A) into instrument finisher C upper side, and then disengage metal clips as shown in the figure.

CAUTION:

- Apply protective tape (B) on the part to protect it from damage.
- Remove metal clips slowly so that they are not damaged.
- Never pull instrument finisher C forcefully.

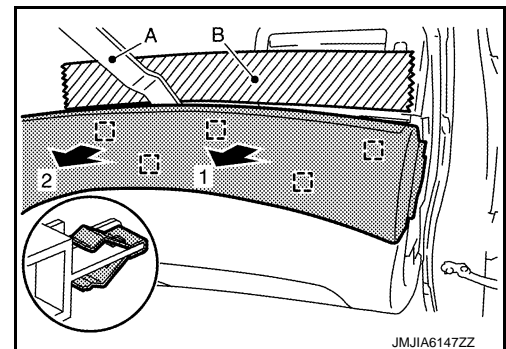

INSTRUMENT PANEL ASSEMBLY

< REMOVAL AND INSTALLATION >

- d. Insert a remover tool (A) into lower left side, and then disengage metal clips as shown in the figure.

CAUTION:

- Apply protective tape (B) on the part to protect it from damage.
- Remove metal clips slowly so that they are not damaged.
- Never pull instrument finisher C forcefully.

 : Metal clip

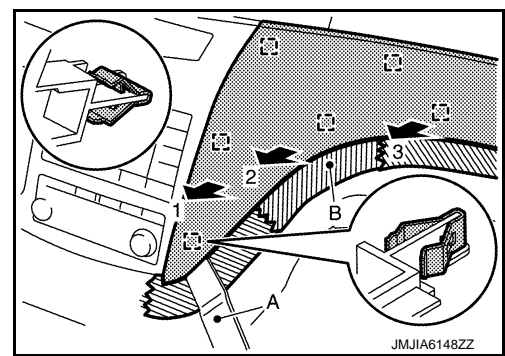

- e. Bypassing hooks, pull back instrument finisher C.

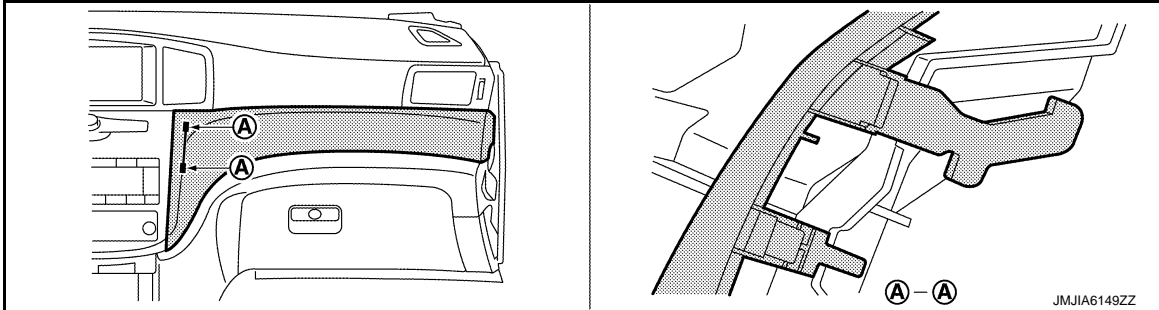

33. Remove selector lever knob. Refer to [TM-185, "Removal and Installation"](#).

34. Remove cluster lid C.

- Remove fixing screws (A).
- Hold both cluster lid C and pull it out towards vehicle rear, and then disengage metal clips.
- Disconnect harness connectors and remove harness clip.

 : Metal clip

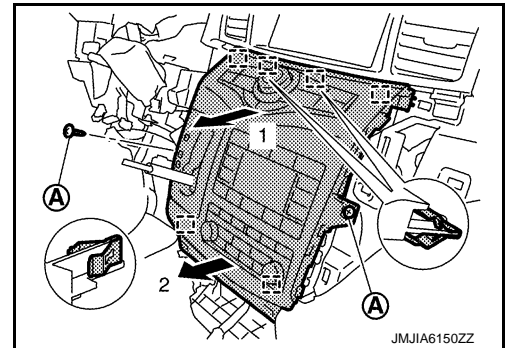

35. Remove cluster lid D.

- Remove fixing screws (A).

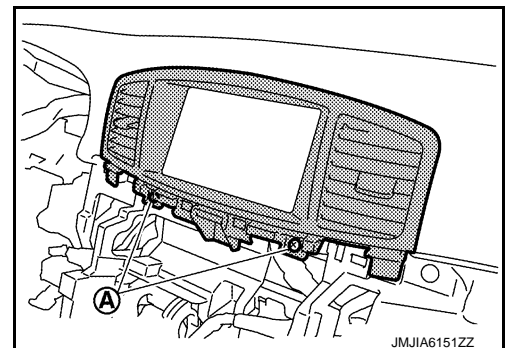

A
B
C
D
E
F
G
H
I
IP
K
L
M
N
O
P

INSTRUMENT PANEL ASSEMBLY

< REMOVAL AND INSTALLATION >

- b. Insert a remover tool (A) into cluster lid D LH and RH lower space, and then disengage pawls as shown in the figure.

 : Pawl

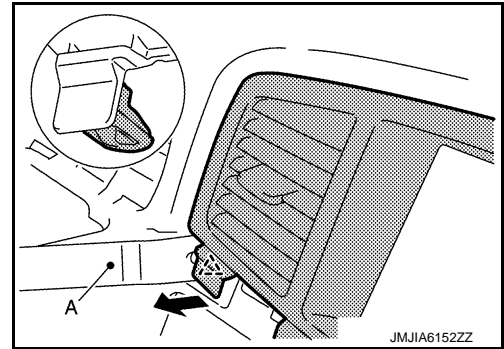

- c. Insert a remover tool (A) into cluster lid D LH and RH side space, and then disengage pawls as shown in the figure.

CAUTION:

- Apply protective tape (B) on the part to protect it from damage.
- Remove metal clips slowly so that they are not damaged.
- Never pull cluster lid D forcefully.

 : Pawl

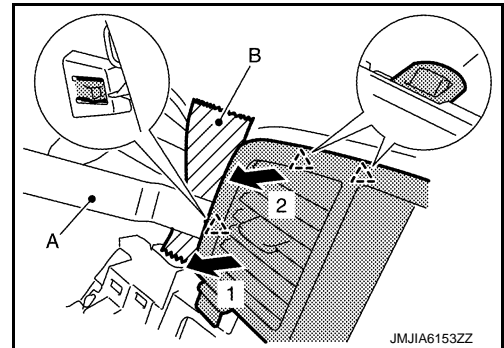

- d. Pull back cluster lid D, and then disengage the pawls.

36. Remove front display. Refer to the following.

- For Base audio with separate display: Refer to [AV-239, "Removal and Installation"](#).
- For Bose audio without navigation: Refer to [AV-392, "Removal and Installation"](#).
- For Bose audio with navigation: Refer to [AV-601, "Removal and Installation"](#).

37. Remove center speaker grille (With BOSE audio and navigation).

- a. Insert a remover tool (A) between center speaker grille and instrument panel assembly to disengage pawls as shown in the figure.

- b. Pull up center speaker grille.

CAUTION:

- Apply protective tape (B) on the part to protect it from damage.
- Remove pawls slowly so that they are not damaged.

 : Pawl

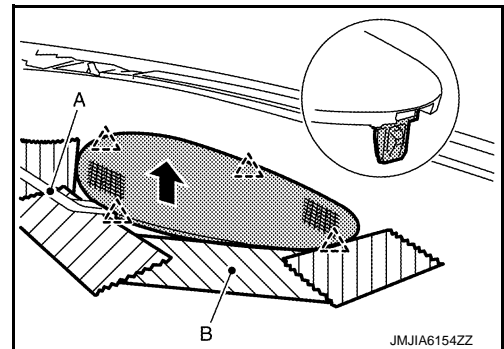

38. Remove center squawker (With BOSE audio and navigation). Refer to [AV-609, "Removal and Installation"](#).

39. Remove glove box assembly.

- a. Slightly open glove box assembly.

- b. Pull the glove box assembly diagonally toward vehicle rear upper direction to remove glove box assembly from instrument lower panel RH.

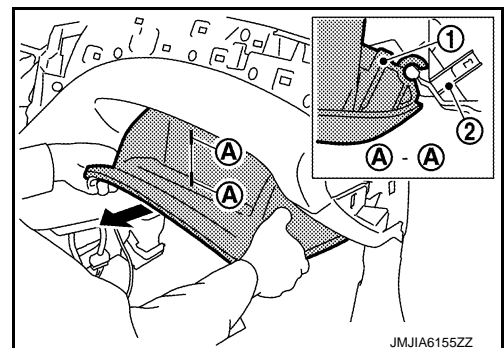

INSTRUMENT PANEL ASSEMBLY

< REMOVAL AND INSTALLATION >

- c. Remove glove box damper pin on right side.

CAUTION:

Never excessively pull string of glove box damper.

 : Clip

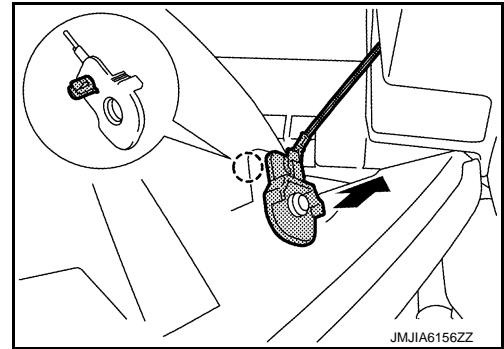

40. Remove instrument lower panel RH.

- a. Remove fixing screws (A).
b. Pull back instrument lower panel RH, and then disengage pawls and metal clips.
c. Disconnect harness connectors and remove harness clips.

 : Pawl

 : Metal clip

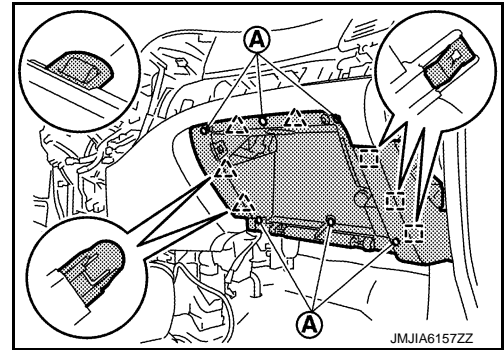

41. Disconnect passenger air bag module harness connector.

42. Remove passenger air bag module fixing bolt. Refer to [SR-18. "Exploded View"](#).

43. Remove cup holder assembly.

- a. Remove fixing screws (A).
b. Pull back cup holder assembly.

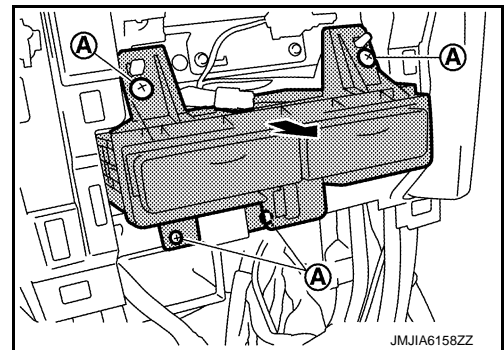

A
B
C
D
E
F
G
H
I
IP
K
L
M
N
O
P

INSTRUMENT PANEL ASSEMBLY

< REMOVAL AND INSTALLATION >

44. Remove instrument panel assembly.

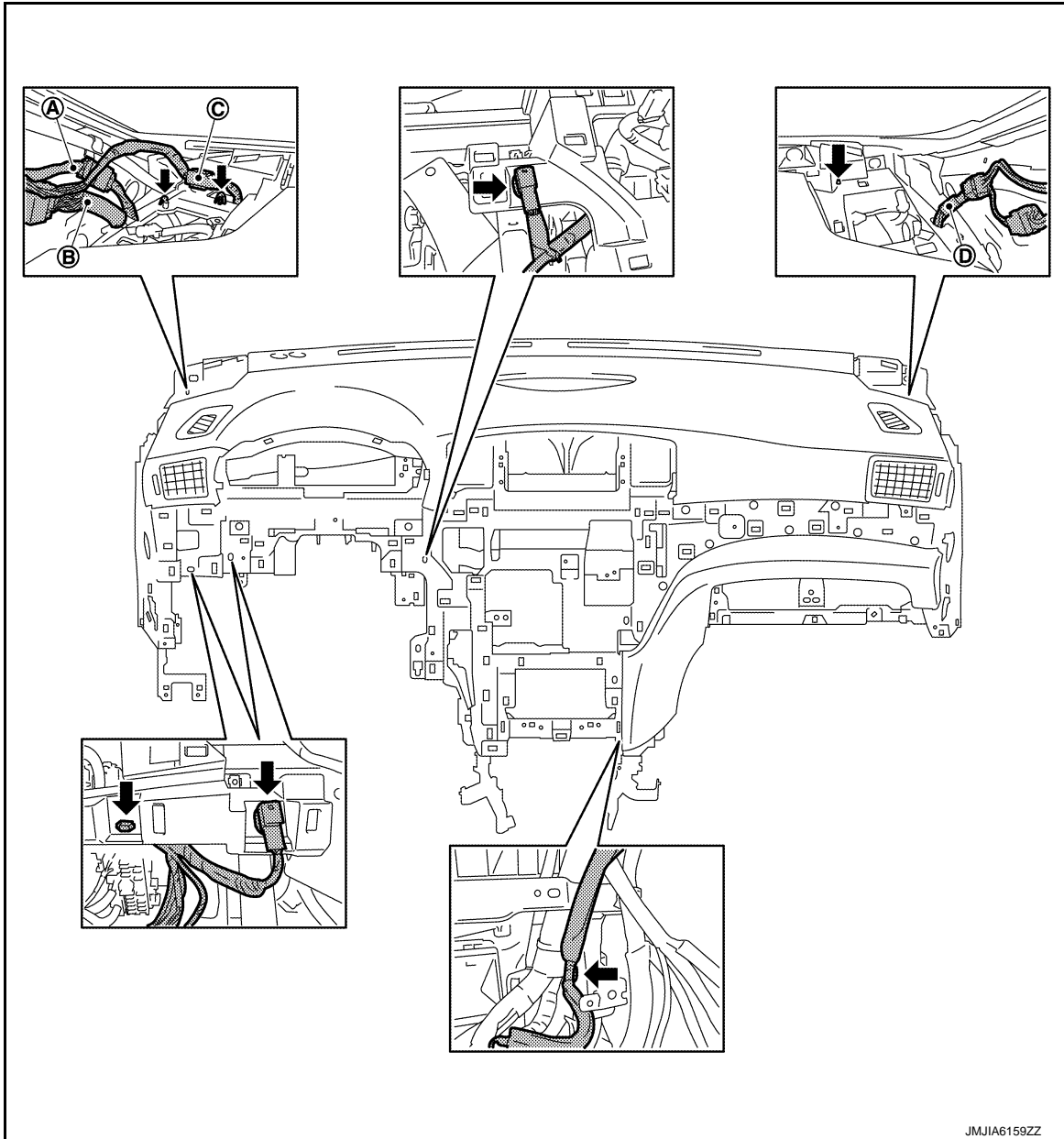

← Harness clip

- Remove harness clips from instrument panel assembly.
- Disengage harness (A), harness (B) and harness (D) of front pillar LH and RH portions from instrument panel assembly.
- Disconnect harness connector (C).

INSTRUMENT PANEL ASSEMBLY

< REMOVAL AND INSTALLATION >

- d. Remove instrument panel assembly fixing screws (A), bolts (B).

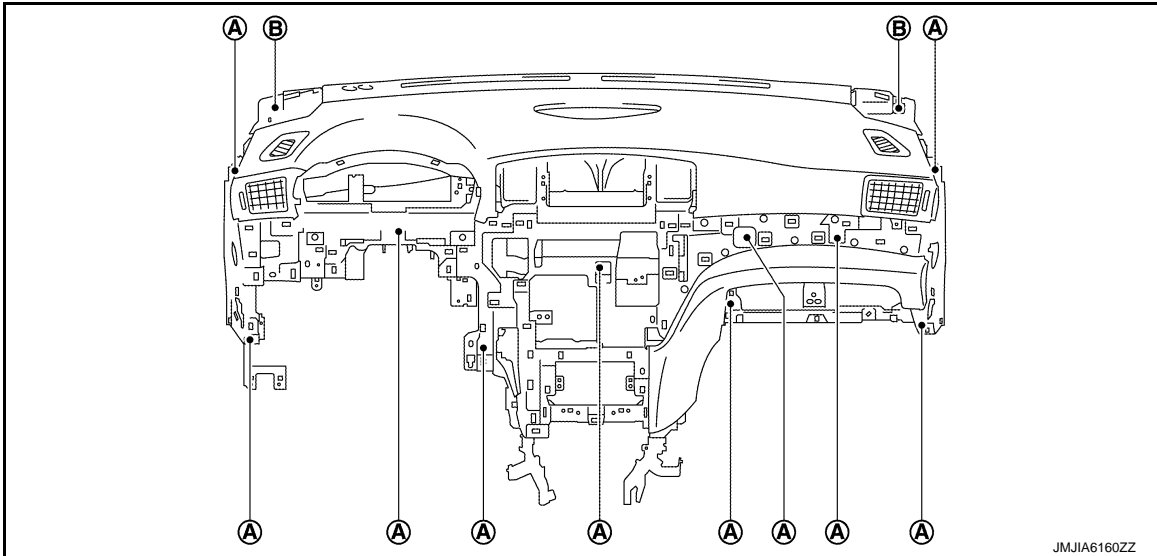

- e. Remove instrument panel assembly from passenger door opening portion.

CAUTION:

- Cover tool with a shop cloth to prevent windshield glass from being damaged.
- Cover center console upper surface with a shop cloth to prevent it from being damaged.
- When removing instrument panel assembly, 2 workers are required so as to prevent it from dropping.

45. Remove instrument upper garnish.

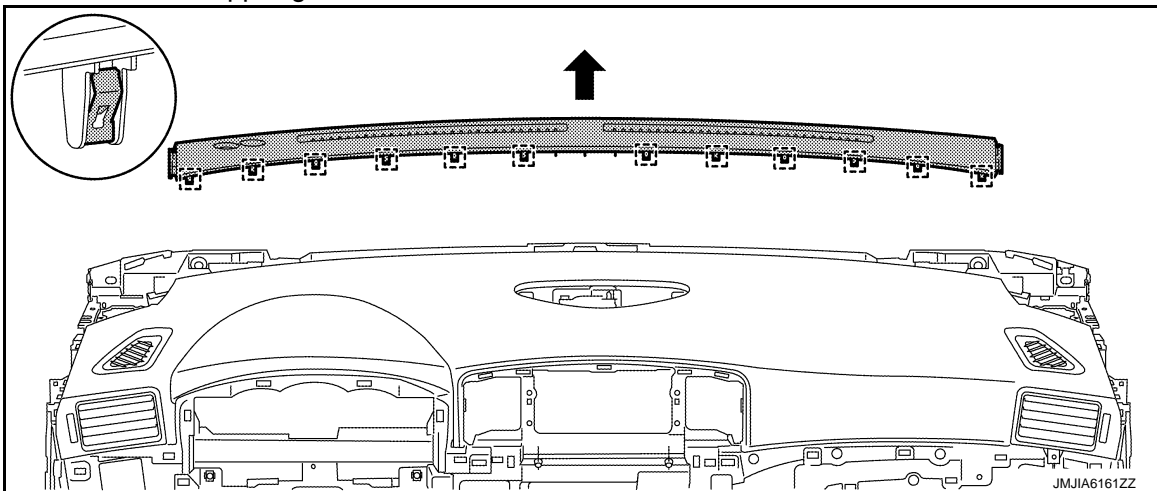

 : Metal clip

- Insert a remover tool between instrument upper garnish and instrument panel assembly to disengage metal clips.
- Remove instrument upper garnish.

46. Remove the following parts after removing instrument panel assembly.

- Front passenger air bag module: Refer to [SR-18, "Removal and Installation"](#).
- Side ventilator grille (LH/RH): Refer to [VTL-10, "SIDE VENTILATOR GRILLE : Removal and Installation"](#).
- Center ventilator duct: Refer to [VTL-10, "CENTER VENTILATOR DUCT : Removal and Installation"](#).
- Side ventilator duct: Refer to [VTL-10, "CENTER VENTILATOR DUCT : Removal and Installation"](#).
- Front defroster nozzle: Refer to [VTL-11, "FRONT DEFROSTER NOZZLE : Removal and Installation"](#).
- Side defroster nozzle: Refer to [VTL-11, "SIDE DEFROSTER NOZZLE : Removal and Installation"](#).
- GPS antenna: Refer to [AV-619, "Removal and Installation"](#).

INSTRUMENT PANEL ASSEMBLY

< REMOVAL AND INSTALLATION >

- Inside key antenna (instrument center) and harness clamp. Refer to [DLK-481, "INSTRUMENT CENTER : Removal and Installation"](#).

INSTALLATION

Note the following items, and then install in the reverse order of removal.

CAUTION:

- **Never use the steering wheel mounting nut after removal, replace with the new nut.**
- **Never use the driver air bag module mounting bolts after removal, replace with the new bolts.**
- **Never use the passenger air bag module mounting bolt after removal, replace with the new bolt.**

CENTER CONSOLE ASSEMBLY

< REMOVAL AND INSTALLATION >

CENTER CONSOLE ASSEMBLY

Exploded View

INFOID:000000011323526

CENTER CONSOLE ASSEMBLY (With NAVI)

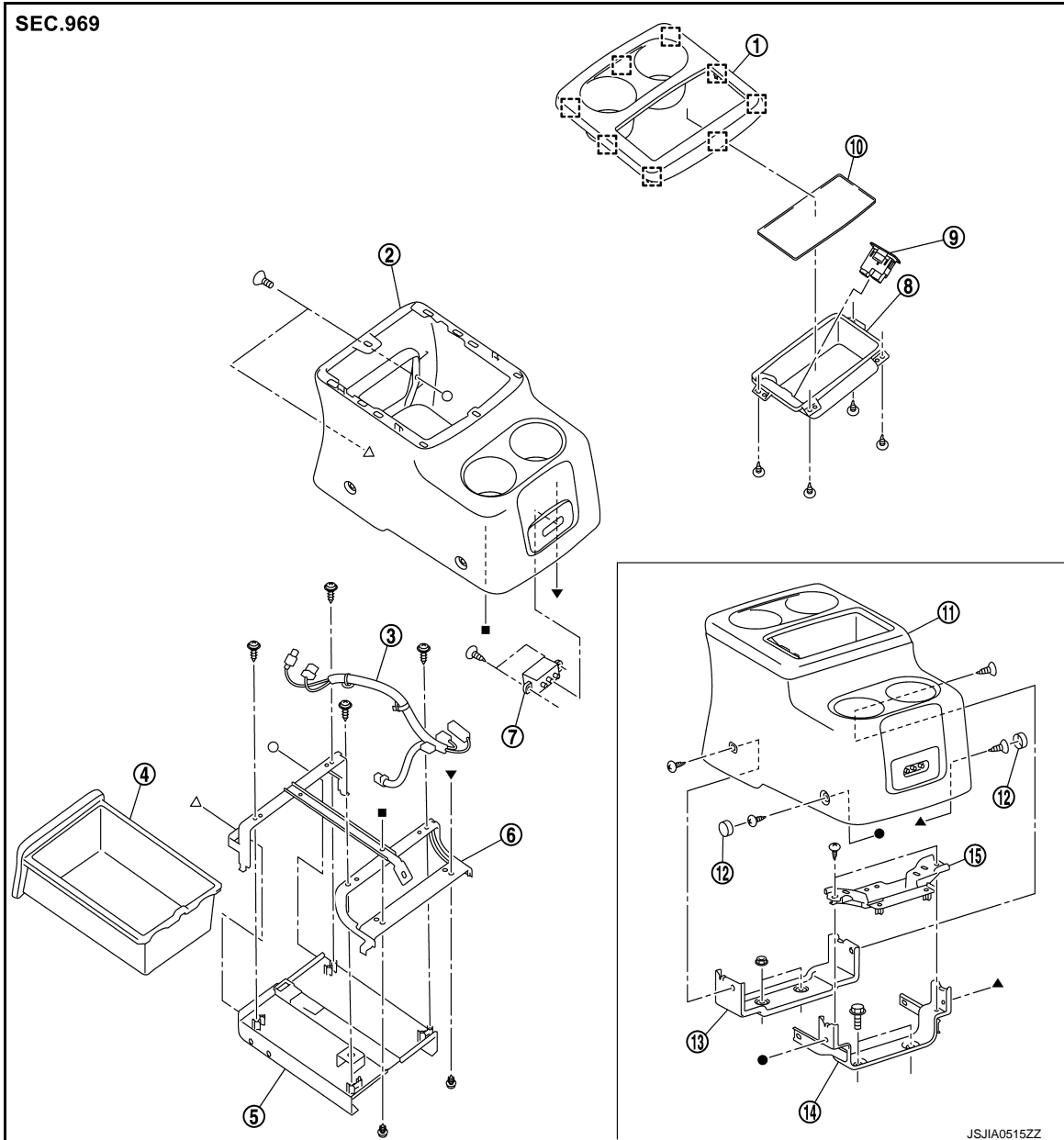

- | | | |
|----------------------------------|---------------------------------|-------------------------------------|
| 1. Center console upper finisher | 2. Center console body assembly | 3. Console sub-harness |
| 4. Console pocket assembly | 5. Console pocket rail | 6. Center console center bracket 2 |
| 7. VTR jacks | 8. Console tray | 9. Jack audio |
| 10. Mat | 11. Center console assembly | 12. Cap |
| 13. Center console front bracket | 14. Center console rear bracket | 15. Center console center bracket 1 |

☐ : Metal clip

●, ▲, ▼, ■, ○, △ : Indicates that the part is connected at points with same symbol in actual vehicle.

A
B
C
D
E
F
G
H
I
IP
K
L
M
N
O
P

CENTER CONSOLE ASSEMBLY

< REMOVAL AND INSTALLATION >

CENTER CONSOLE ASSEMBLY (Without NAVI)

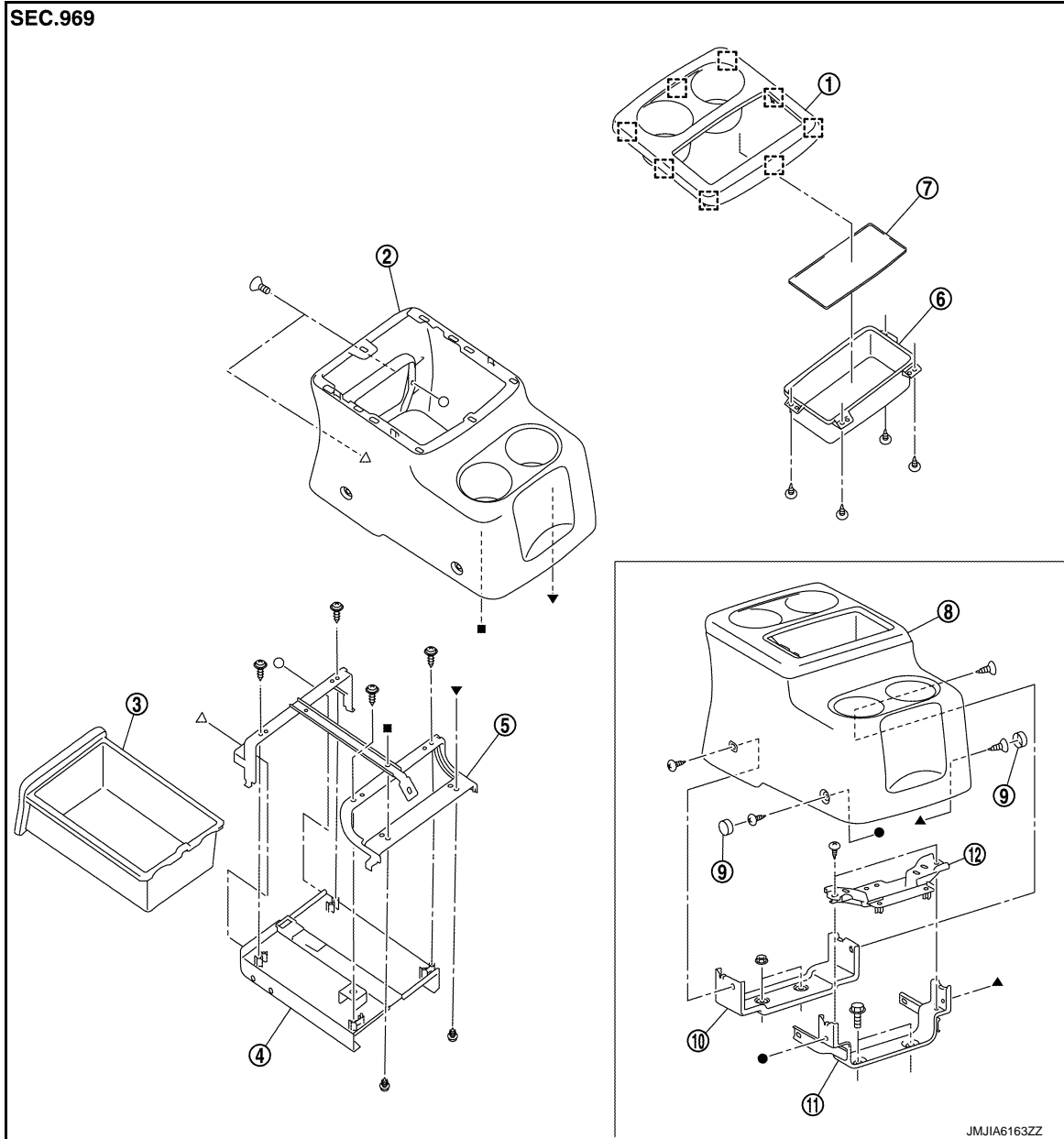

- | | | |
|----------------------------------|------------------------------------|-------------------------------------|
| 1. Center console upper finisher | 2. Center console body assembly | 3. Console pocket assembly |
| 4. Console pocket rail | 5. Center console center bracket 2 | 6. Console tray |
| 7. Mat | 8. Center console assembly | 9. Cap |
| 10. Center console front bracket | 11. Center console rear bracket | 12. Center console center bracket 1 |

☐ : Metal clip

●, ▲, ▼, ■, ○, △ : Indicates that the part is connected at points with same symbol in actual vehicle.

Removal and Installation

INFOID:000000011323527

Removal and Installation

CAUTION:

When removing, always use a remover tool that is made of plastic.

- Remove driver seat assembly and passenger seat assembly.
 - Manual seat: Refer to [SE-89, "Removal and Installation"](#).
 - Power seat: Refer to [SE-103, "Removal and Installation"](#).

CENTER CONSOLE ASSEMBLY

< REMOVAL AND INSTALLATION >

2. Remove center console assembly rear side screw mask with a flat-bladed screwdriver (A).

↶ : Vehicle front

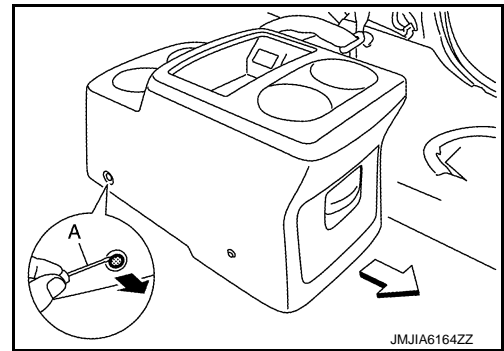

3. Remove center console assembly fixing screws.
4. Lift up center console assembly, disconnect harness connectors.
5. Remove center console assembly.
6. Remove center console assembly brackets.
 - a. Remove mounting bolts (A), and then remove center console center bracket 1 (1).
 - b. Remove mounting bolts (B), and then remove center console front bracket (2).
 - c. Remove harness clip.

○ : Clip

↶ : Vehicle front

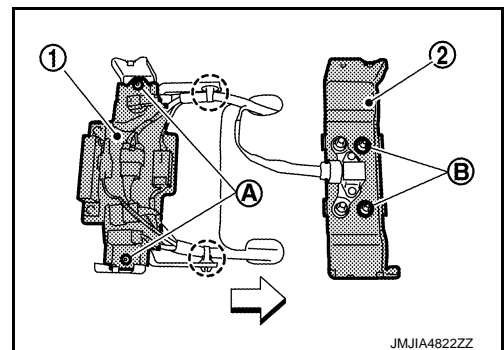

- d. Remove mounting bolts (C), and then remove center console rear bracket.

↶ : Vehicle front

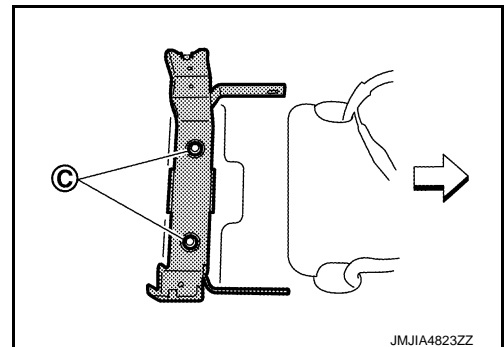

INSTALLATION

Install in the reverse order of removal.

Disassembly and Assembly

INFOID:000000011323528

Disassembly and Assembly

CAUTION:

To prevent damage to the parts, when disassembling, always use a remover tool that is made of plastic.

DISASSEMBLY

1. Remove center console assembly. Refer to [IP-28. "Removal and Installation"](#).
2. Remove center console upper finisher.

CENTER CONSOLE ASSEMBLY

< REMOVAL AND INSTALLATION >

- a. Insert a remover tool (A) between center console upper finisher and center console body assembly to disengage the metal clips as shown in the figure.
- b. Disconnect harness connectors.

CAUTION:

Apply protective tape (B) on the part to protect it from damage.

 : Metal clip

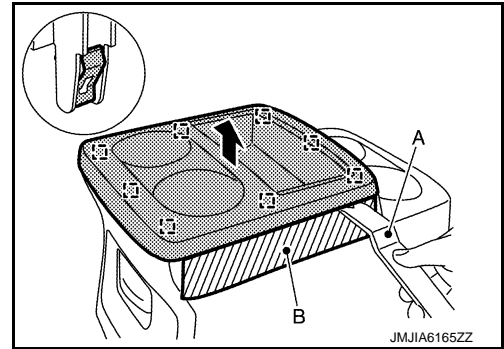

NOTE:

- For removal and installation of power outlet, refer to [PWO-36, "Removal and Installation"](#).
- For removal and installation of USB connector, refer to the following.
 - For Display audio: Refer to [AV-107, "Removal and Installation"](#).
 - For Base audio with separate display: Refer to [AV-248, "Removal and Installation"](#).
 - For Bose audio without navigation: Refer to [AV-406, "Removal and Installation"](#).
 - For Bose audio with navigation: Refer to [AV-615, "Removal and Installation"](#).

3. Remove console pocket assembly.
 - a. Pull console pocket assembly.
 - b. Lift up console pocket rail stopper (B), and then disengage to pull console pocket assembly from center console assembly as shown in the figure.

CAUTION:

Never excessively pull up console pocket rail stopper forcefully.

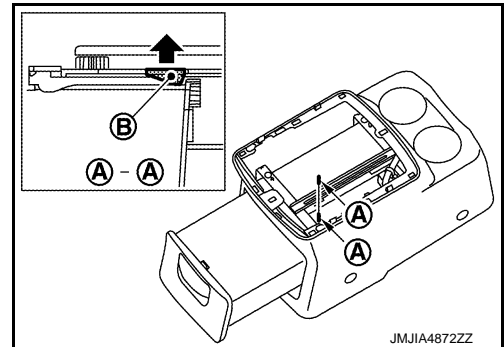

4. Remove console pocket rail.
 - a. Remove fixing screws (A).

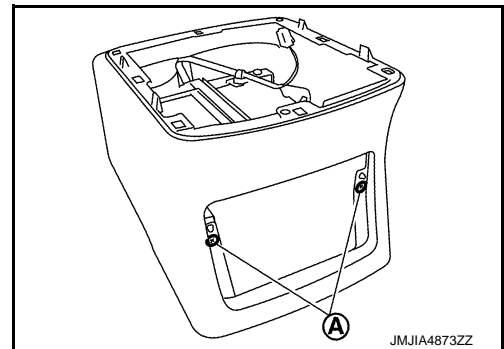

- b. Remove fixing screws (B).
- c. Remove harness clip (C) from center console center bracket 2 (With NAVI or DVD player).

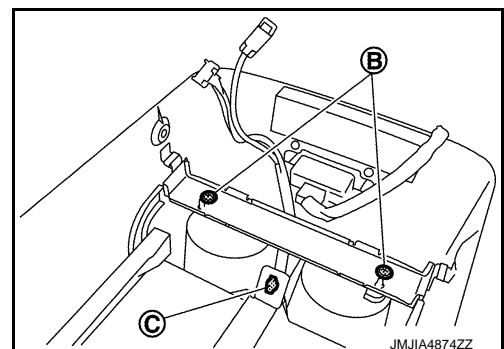

CENTER CONSOLE ASSEMBLY

< REMOVAL AND INSTALLATION >

5. Remove console harness (1) fixing harness clip (A) from console pocket rail (2) (With NAVI or DVD player).

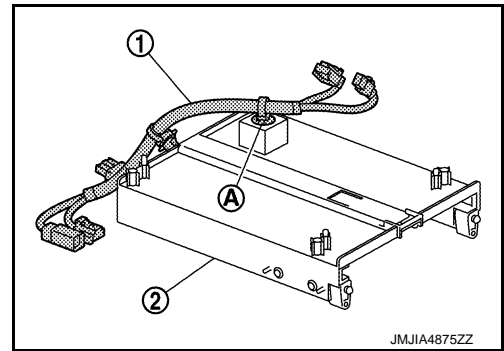

6. Remove VTR jacks (if equipped), refer to the following.
- For Base audio with separate display: Refer to [AV-247, "Removal and Installation"](#).
 - For Bose audio without navigation: Refer to [AV-405, "Removal and Installation"](#).
 - For Bose audio with navigation: Refer to [AV-614, "Removal and Installation"](#).

ASSEMBLY

Assemble in the reverse order of disassembly.

A
B
C
D
E
F
G
H
I
IP
K
L
M
N
O
P

REAR CONSOLE ASSEMBLY

< REMOVAL AND INSTALLATION >

REAR CONSOLE ASSEMBLY

Exploded View

INFOID:000000011323529

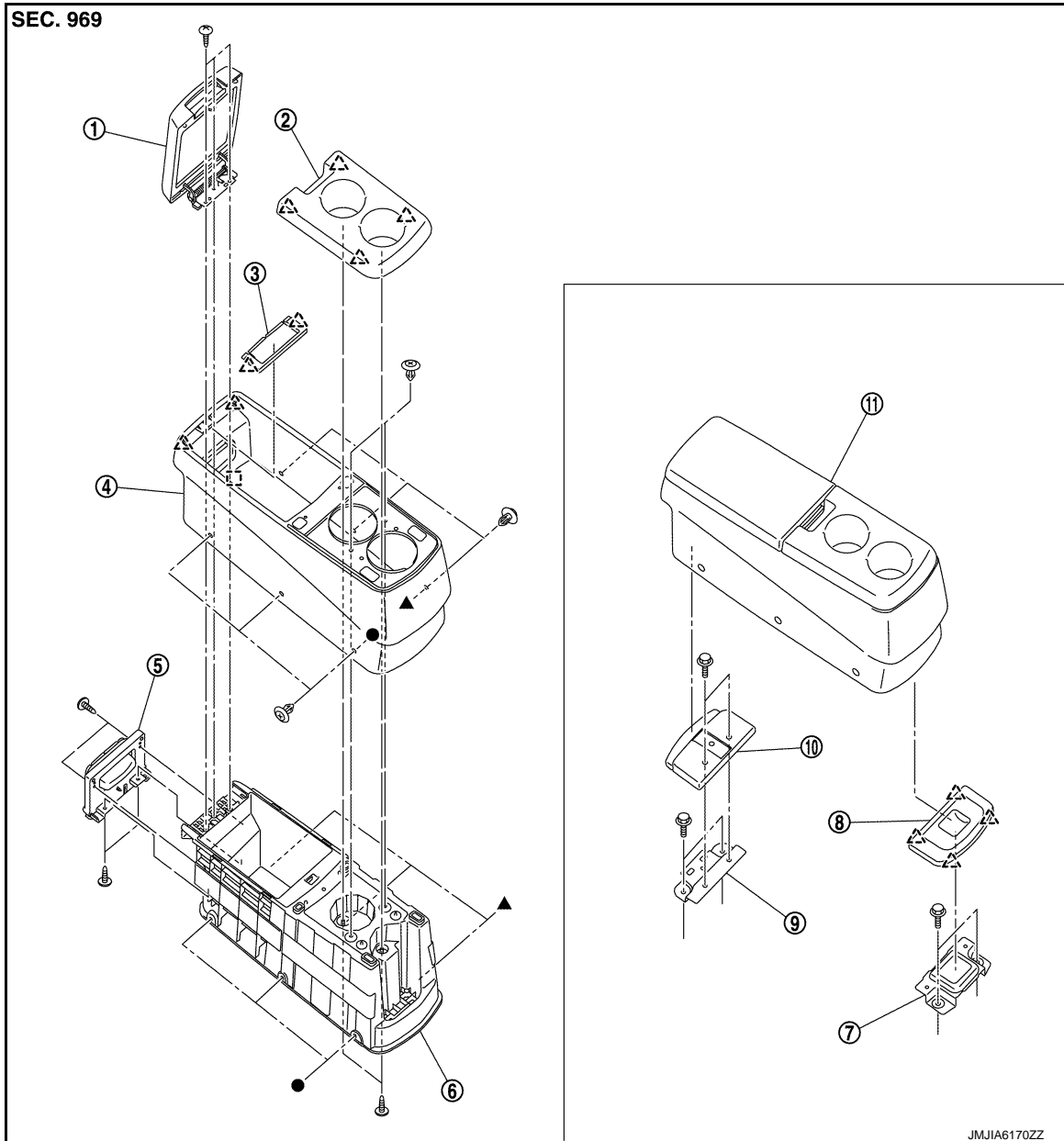

- | | | |
|-------------------------------|--------------------------------|------------------------------|
| 1. Rear console lid assembly | 2. Cup holder | 3. Console mask |
| 4. Rear console body | 5. Rear console latch assembly | 6. Rear console box assembly |
| 7. Rear console front bracket | 8. Rear console front base | 9. Rear console rear bracket |
| 10. Rear console rear base | 11. Rear console assembly | |

△ : Pawl

□ : Metal clip

●, ▲ : Indicates that the part is connected at points with same symbol in actual vehicle.

Removal and Installation

INFOID:000000011323530

CAUTION:

When removing, always use a remover tool that is made of plastic.

REAR CONSOLE ASSEMBLY

< REMOVAL AND INSTALLATION >

REMOVAL

1. Remove rear console assembly.
Pull up latch handle of console latch assembly, and then remove rear console assembly sliding toward vehicle rear.

← : Vehicle front

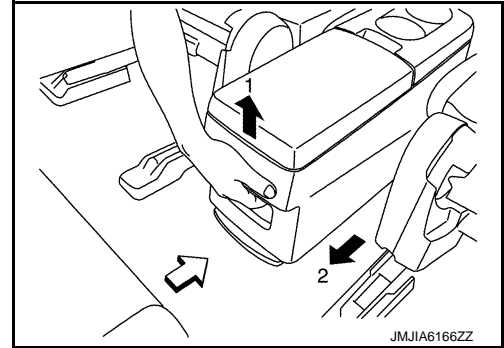

2. Remove rear console bases and brackets.
 - a. Insert a remover tool (A) between rear console front base and body floor to disengage the pawls as shown in the figure.

△ Pawl
← : Vehicle front

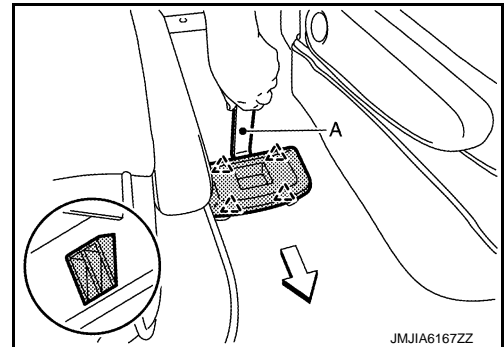

- b. Remove fixing bolts (A), and then remove rear console front bracket.

← : Vehicle front

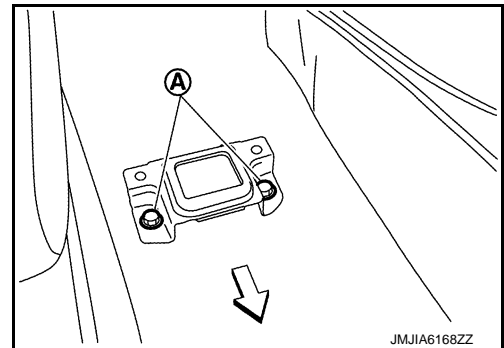

- c. Remove fixing bolts (A), and then remove rear console rear base.

← : Vehicle front

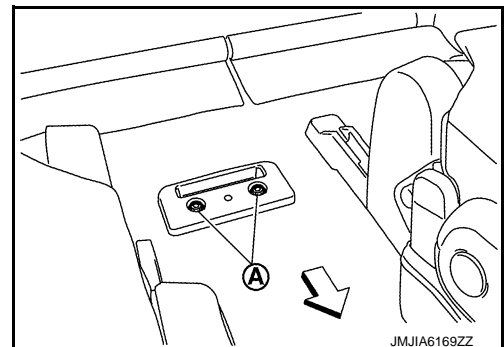

- d. Remove fixing bolts, and then remove rear console rear bracket.

INSTALLATION

Install in the reverse order of removal.

Disassembly and Assembly

INFOID:000000011323531

Disassembly and Assembly of Rear Console Assembly.

CAUTION:

A
B
C
D
E
F
G
H
I
IP
K
L
M
N
O
P

REAR CONSOLE ASSEMBLY

< REMOVAL AND INSTALLATION >

When disassembling, always use a remover tool that is made of plastic.

DISASSEMBLY

1. Remove rear console assembly. Refer to [IP-32, "Removal and Installation"](#).
2. Remove rear console lid assembly.
 - a. Open the console lid.
 - b. Insert remover tool (A) between console mask and rear console box assembly to disengage the pawls as shown in the figure.

 : Pawl

CAUTION:
Apply protective tape (B) on the part to protect it from damage.

- c. Pull up console mask.
 - d. Remove fixing screws (A), and then remove rear console lid assembly.

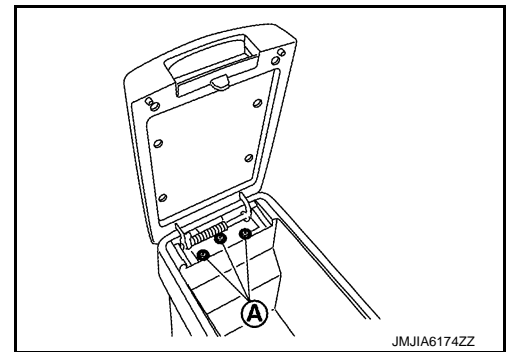
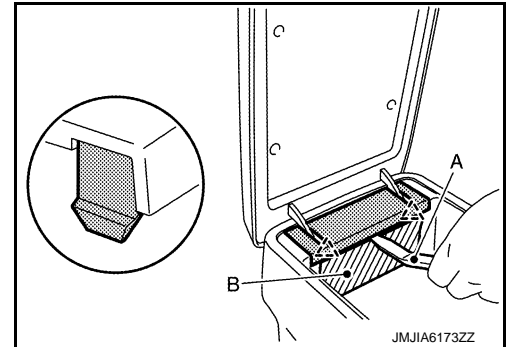

3. Remove cup holder.
 - a. Remove fixing screws (A).

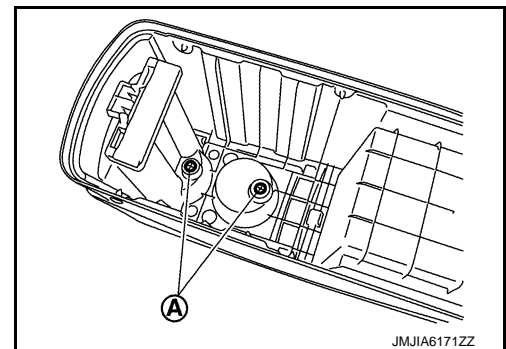

- b. Pull up cup holder.
CAUTION:
Remove pawls slowly so that they are not damaged.

 : Pawl

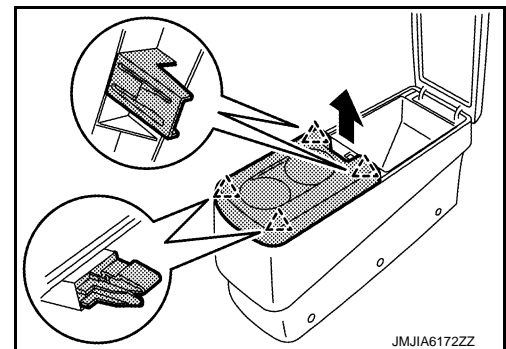

4. Remove rear console body.

REAR CONSOLE ASSEMBLY

< REMOVAL AND INSTALLATION >

- a. Remove rear console body fixing clips (A).

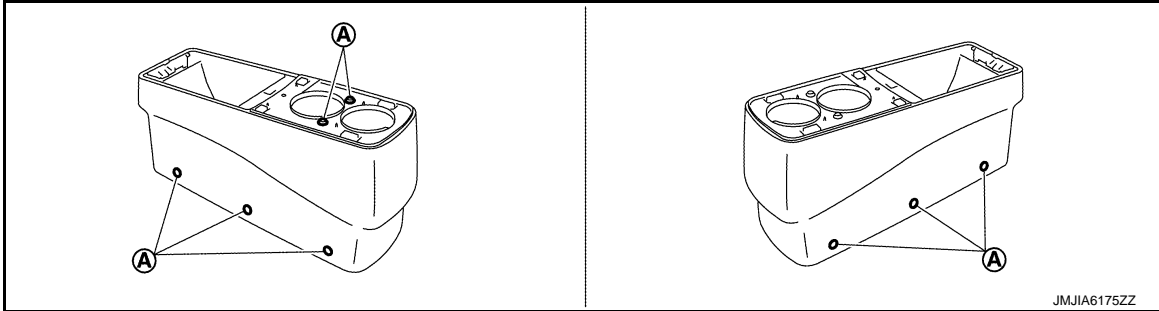

- b. Remove rear console body from rear console box assembly, bypassing both upper side pawls of rear console body.

CAUTION:

Remove pawls slowly so that they are not damaged.

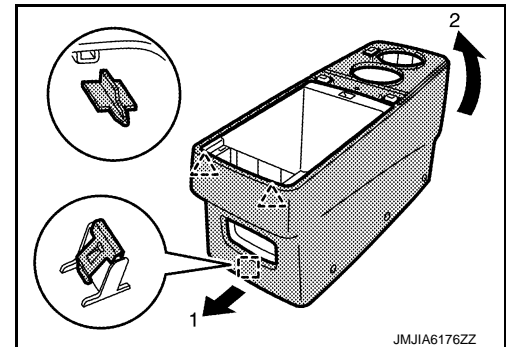
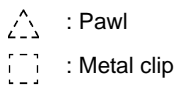

5. Remove fixing screws (A), and then remove rear console latch assembly.

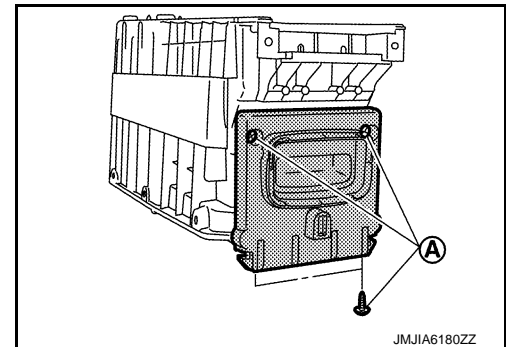

ASSEMBLY

Assemble in reverse order of disassembly.

A
B
C
D
E
F
G
H
I
IP
K
L
M
N
O
P