

MWI

SECTION

METER, WARNING LAMP & INDICATOR

A
B
C
D
E
F
G
H
I
J
K
L
M
O
P

CONTENTS

PRECAUTION	4	OIL PRESSURE WARNING LAMP : System Description	16
PRECAUTIONS	4	MASTER WARNING LAMP	16
Precaution for Supplemental Restraint System (SRS) "AIR BAG" and "SEAT BELT PRE-TENSIONER"	4	MASTER WARNING LAMP : System Description...	17
Precautions for Removing Battery Terminal	4	METER ILLUMINATION CONTROL	17
PREPARATION	5	METER ILLUMINATION CONTROL : System Description	17
PREPARATION	5	METER EFFECT FUNCTION	18
Commercial Service Tools	5	METER EFFECT FUNCTION : System Description	19
SYSTEM DESCRIPTION	6	INFORMATION DISPLAY	21
COMPONENT PARTS	6	INFORMATION DISPLAY : System Description	21
METER SYSTEM	6	COMPASS	32
METER SYSTEM : Component Parts Location	6	System Description	32
METER SYSTEM : Combination Meter	7	OPERATION	33
METER SYSTEM : Meter Control Switch and Illumination Control Switch	8	Switch Name and Function	33
METER SYSTEM	9	DIAGNOSIS SYSTEM (COMBINATION METER)	34
METER SYSTEM	9	On Board Diagnosis Function	34
METER SYSTEM : System Description	9	CONSULT Function	35
METER SYSTEM : Circuit Diagram	13	ECU DIAGNOSIS INFORMATION	40
METER SYSTEM : Fail-Safe	13	COMBINATION METER	40
SPEEDOMETER	14	Reference Value	40
SPEEDOMETER : System Description	15	Fail-Safe	47
TACHOMETER	15	DTC Index	48
TACHOMETER : System Description	15	IPDM E/R	49
ENGINE COOLANT TEMPERATURE GAUGE	15	List of ECU Reference	49
ENGINE COOLANT TEMPERATURE GAUGE : System Description	15	WIRING DIAGRAM	50
FUEL GAUGE	16	METER SYSTEM	50
FUEL GAUGE : System Description	16	Wiring Diagram	50
OIL PRESSURE WARNING LAMP	16	COMPASS	59

MWI

Wiring Diagram	59	WASHER LEVEL SWITCH SIGNAL CIRCUIT...	78
BASIC INSPECTION	61	Diagnosis Procedure	78
DIAGNOSIS AND REPAIR WORKFLOW		Component Inspection	78
(METER SYSTEM)	61	A/C AUTO AMP. CONNECTION RECOGNITION SIGNAL CIRCUIT	79
Work flow	61	Diagnosis Procedure	79
ZONE VARIATION SETTING (COMPASS)	64	SYMPTOM DIAGNOSIS	80
Work Procedure	64	THE FUEL GAUGE INDICATOR DOES NOT OPERATE	80
CALIBRATION (COMPASS)	65	Description	80
Work Procedure	65	Diagnosis Procedure	80
DTC/CIRCUIT DIAGNOSIS	66	THE METER CONTROL SWITCH IS INOPERATIVE	81
U1000 CAN COMM CIRCUIT	66	Description	81
Description	66	Diagnosis Procedure	81
DTC Logic	66	THE ILLUMINATION CONTROL SWITCH IS INOPERATIVE	82
Diagnosis Procedure	66	Description	82
U1010 CONTROL UNIT (CAN)	67	Diagnosis Procedure	82
Description	67	THE OIL PRESSURE WARNING LAMP DOES NOT TURN ON	83
DTC Logic	67	Description	83
Diagnosis Procedure	67	Diagnosis Procedure	83
B2205 VEHICLE SPEED	68	THE OIL PRESSURE WARNING LAMP DOES NOT TURN OFF	84
Description	68	Description	84
DTC Logic	68	Diagnosis Procedure	84
Diagnosis Procedure	68	THE PARKING BRAKE RELEASE WARNING CONTINUES DISPLAYING, OR DOES NOT DISPLAY	85
B2267 ENGINE SPEED	69	Description	85
Description	69	Diagnosis Procedure	85
DTC Logic	69	THE LOW WASHER FLUID WARNING CONTINUES DISPLAYING, or DOES NOT DISPLAY	86
Diagnosis Procedure	69	Description	86
B2268 WATER TEMP	70	Diagnosis Procedure	86
Description	70	THE DOOR OPEN WARNING CONTINUES DISPLAYING, OR DOES NOT DISPLAY	87
DTC Logic	70	Description	87
Diagnosis Procedure	70	Diagnosis Procedure	87
POWER SUPPLY AND GROUND CIRCUIT	71	THE AMBIENT TEMPERATURE DISPLAY IS INCORRECT	88
COMBINATION METER	71	Description	88
COMBINATION METER : Diagnosis Procedure ...	71	Diagnosis Procedure	88
METER CONTROL SWITCH SIGNAL CIRCUIT	72	NORMAL OPERATING CONDITION	89
Diagnosis Procedure	72	COMPASS	89
Component Inspection	72	COMPASS : Description	89
ILLUMINATION CONTROL SWITCH SIGNAL CIRCUIT	74		
Diagnosis Procedure	74		
Component Inspection	74		
FUEL LEVEL SENSOR SIGNAL CIRCUIT	76		
Description	76		
Component Function Check	76		
Diagnosis Procedure	76		
Component Inspection	77		

INFORMATION DISPLAY	89	Exploded View	92	
INFORMATION DISPLAY : Description	89	Removal and Installation	92	A
REMOVAL AND INSTALLATION	90	ILLUMINATION CONTROL SWITCH	93	
COMBINATION METER	90	Exploded View	93	B
Exploded View	90	Removal and Installation	93	
Removal and Installation	90	COMPASS	94	
Disassembly and Assembly	90	Exploded View	94	C
METER CONTROL SWITCH	92	Removal and Installation	94	

D
E
F
G
H
I
J
K
L
M
O
P

MWI

PRECAUTIONS

< PRECAUTION >

PRECAUTION

PRECAUTIONS

Precaution for Supplemental Restraint System (SRS) "AIR BAG" and "SEAT BELT PRE-TENSIONER"

INFOID:000000011324076

The Supplemental Restraint System such as "AIR BAG" and "SEAT BELT PRE-TENSIONER", used along with a front seat belt, helps to reduce the risk or severity of injury to the driver and front passenger for certain types of collision. This system includes seat belt switch inputs and dual stage front air bag modules. The SRS system uses the seat belt switches to determine the front air bag deployment, and may only deploy one front air bag, depending on the severity of a collision and whether the front occupants are belted or unbelted. Information necessary to service the system safely is included in the "SRS AIR BAG" and "SEAT BELT" of this Service Manual.

WARNING:

Always observe the following items for preventing accidental activation.

- To avoid rendering the SRS inoperative, which could increase the risk of personal injury or death in the event of a collision that would result in air bag inflation, all maintenance must be performed by an authorized NISSAN/INFINITI dealer.
- Improper maintenance, including incorrect removal and installation of the SRS, can lead to personal injury caused by unintentional activation of the system. For removal of Spiral Cable and Air Bag Module, see "SRS AIR BAG".
- Never use electrical test equipment on any circuit related to the SRS unless instructed to in this Service Manual. SRS wiring harnesses can be identified by yellow and/or orange harnesses or harness connectors.

PRECAUTIONS WHEN USING POWER TOOLS (AIR OR ELECTRIC) AND HAMMERS

WARNING:

Always observe the following items for preventing accidental activation.

- When working near the Air Bag Diagnosis Sensor Unit or other Air Bag System sensors with the ignition ON or engine running, never use air or electric power tools or strike near the sensor(s) with a hammer. Heavy vibration could activate the sensor(s) and deploy the air bag(s), possibly causing serious injury.
- When using air or electric power tools or hammers, always switch the ignition OFF, disconnect the battery, and wait at least 3 minutes before performing any service.

Precautions for Removing Battery Terminal

INFOID:000000011324077

- When removing the 12V battery terminal, turn OFF the ignition switch and wait at least 30 seconds.

NOTE:

ECU may be active for several tens of seconds after the ignition switch is turned OFF. If the battery terminal is removed before ECU stops, then a DTC detection error or ECU data corruption may occur.

- For vehicles with the 2-batteries, be sure to connect the main battery and the sub battery before turning ON the ignition switch.

NOTE:

If the ignition switch is turned ON with any one of the terminals of main battery and sub battery disconnected, then DTC may be detected.

- After installing the 12V battery, always check "Self Diagnosis Result" of all ECUs and erase DTC.

NOTE:

The removal of 12V battery may cause a DTC detection error.

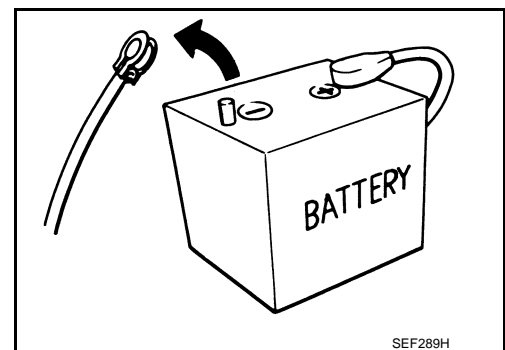

PREPARATION

< PREPARATION >

PREPARATION

PREPARATION

Commercial Service Tools

INFOID:000000011324078

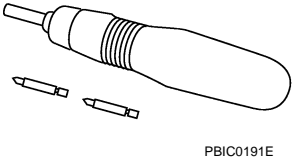
Tool name	Description
<p>Power tool</p>  <p>PBIC0191E</p>	<p>Loosening screws</p>

A

B

C

D

E

F

G

H

I

J

K

L

M

MWI

O

P

COMPONENT PARTS

< SYSTEM DESCRIPTION >

SYSTEM DESCRIPTION

COMPONENT PARTS

METER SYSTEM

METER SYSTEM : Component Parts Location

INFOID:000000011324079

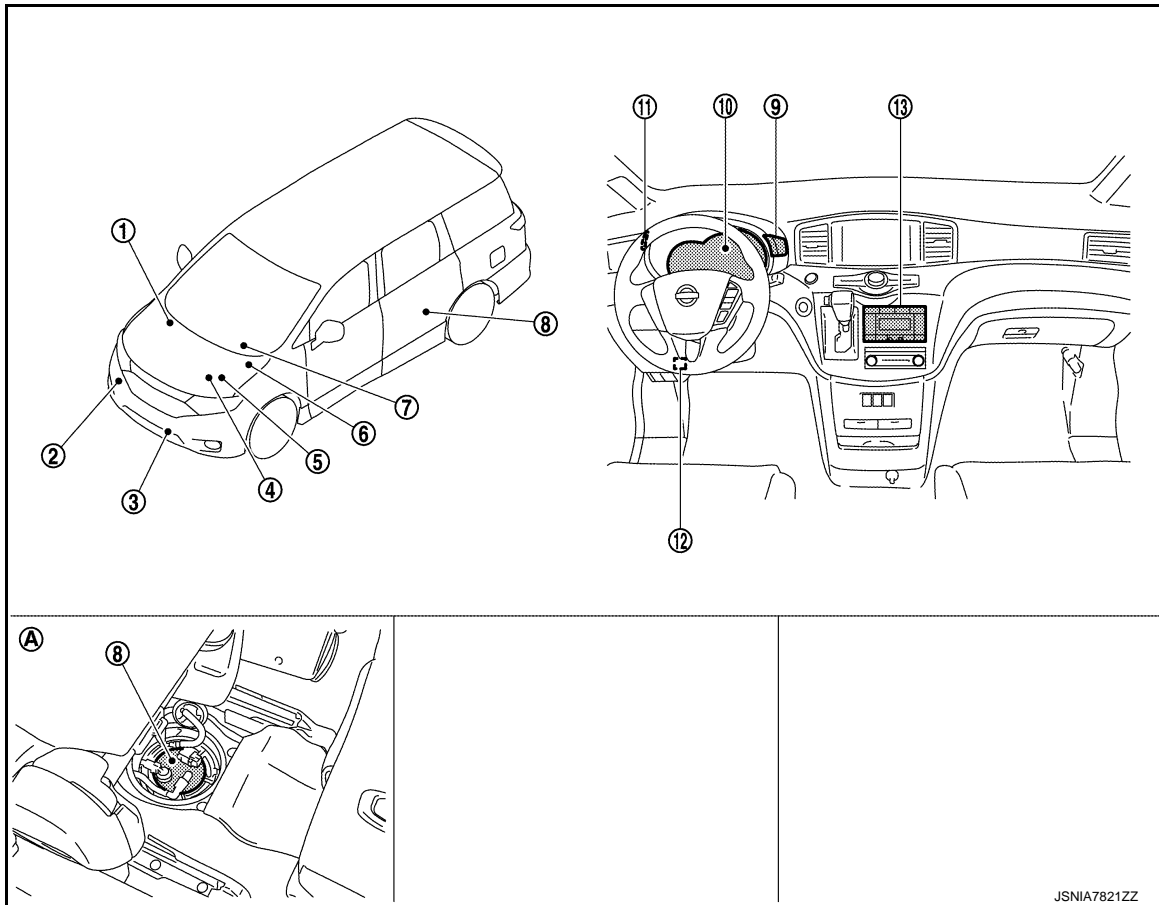

A. Under the left second seat

No.	Component	Function
1.	ABS actuator and electric unit (control unit)	Transmits the vehicle speed signal to the combination meter via CAN communication. Refer to BRC-9, "Component Parts Location" for detailed installation location.
2.	Washer level switch	Transmits the washer level switch signal to the combination meter.
3.	Ambient sensor	Transmits the ambient sensor signal to the IPDM E/R.
4.	TCM	Transmits the shift position signal to the combination meter via CAN communication. Refer to TM-11, "CVT CONTROL SYSTEM : Component Parts Location" for detailed installation location.
5.	ECM	Transmits the following signals to the combination meter via CAN communication. <ul style="list-style-type: none"> • Engine speed signal • Engine coolant temperature signal • Fuel consumption monitor signal • Fuel filler cap warning display signal • Oil pressure warning lamp signal • Engine status signal Refer to EC-16, "ENGINE CONTROL SYSTEM : Component Parts Location" for detailed installation location.

COMPONENT PARTS

< SYSTEM DESCRIPTION >

No.	Component	Function
6.	IPDM E/R	Transmits the ambient sensor signal to the combination meter. Refer to PCS-4. "IPDM E/R : Component Parts Location" for detailed installation location.
7.	BCM	Transmits the following signals to the combination meter via CAN communication. <ul style="list-style-type: none"> • Position light request signal • Door switch signal • Door lock/unlock status signal • Meter display signal • Low tire pressure warning lamp signal • Dimmer signal • Starter relay status signal Refer to BCS-4. "BODY CONTROL SYSTEM : Component Parts Location" for detailed installation location.
8.	Fuel level sensor unit	Transmits the fuel level sensor signal to the combination meter.
9.	Meter control switch	Transmits the following signals to the combination meter. <ul style="list-style-type: none"> • Enter switch signal • Select switch signal • Trip reset switch signal
10.	Combination meter	Refer to MWI-7. "METER SYSTEM : Combination Meter" .
11.	Illumination control switch	Transmits the following signals to the combination meter. <ul style="list-style-type: none"> • Illumination control switch signal (+) • Illumination control switch signal (-)
12.	Parking brake switch	Transmits the parking brake switch signal to the combination meter.
13.	A/C auto amp. (with auto A/C)	Transmits the A/C auto amp. connection recognition signal to the combination meter. Refer to HAC-8. "Component Parts Location" for detailed installation location.

METER SYSTEM : Combination Meter

INFOID:000000011324080

The combination meter controls the following items according to the signals received from each unit via CAN communication and the signals from switches and sensors.

- Measuring instruments
- Indicator lamps
- Warning lamps
- Meter illumination control
- Meter effect function
- Information display

ARRANGEMENT OF COMBINATION METER

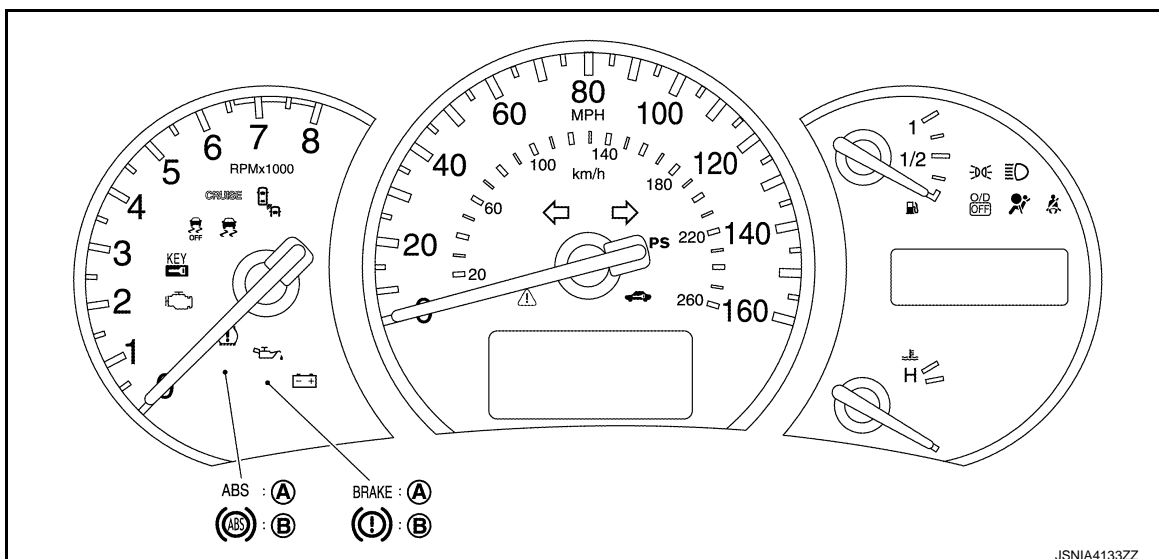

A. For U.S.A

B. For Canada

COMPONENT PARTS

< SYSTEM DESCRIPTION >

METER SYSTEM : Meter Control Switch and Illumination Control Switch

INFOID:000000011324081

- The meter control switch is located on the cluster lid A RH.
- The illumination control switch is located on the cluster lid A LH.

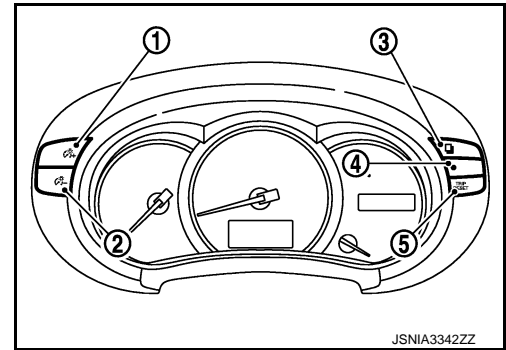

JSNIA3342ZZ

Switch name		Description
Illumination control switch	Illumination control switch (+) (1)	An illuminance level of the back light of the combination meter can be adjusted.
	Illumination control switch (-) (2)	
Meter control switch	Enter switch (3)	<ul style="list-style-type: none"> • The information display screen can be switched. • The item indicated on the information display can be confirmed.
	Select switch (4)	When plural items are shown on the information display, a selected item can be changed to the other item.
	Trip reset switch (5)	<ul style="list-style-type: none"> • The trip meter can be switched between A and B. • Trip meter A/B can be reset by pressing and holding the trip reset switch.

- Transmits the following signals to the combination meter.
 - Illumination control switch signal (+)
 - Illumination control switch signal (-)
 - Enter switch signal
 - Select switch signal
 - Trip reset switch signal

METER SYSTEM

< SYSTEM DESCRIPTION >

METER SYSTEM

METER SYSTEM

METER SYSTEM : System Description

INFOID:000000011324082

SYSTEM DIAGRAM

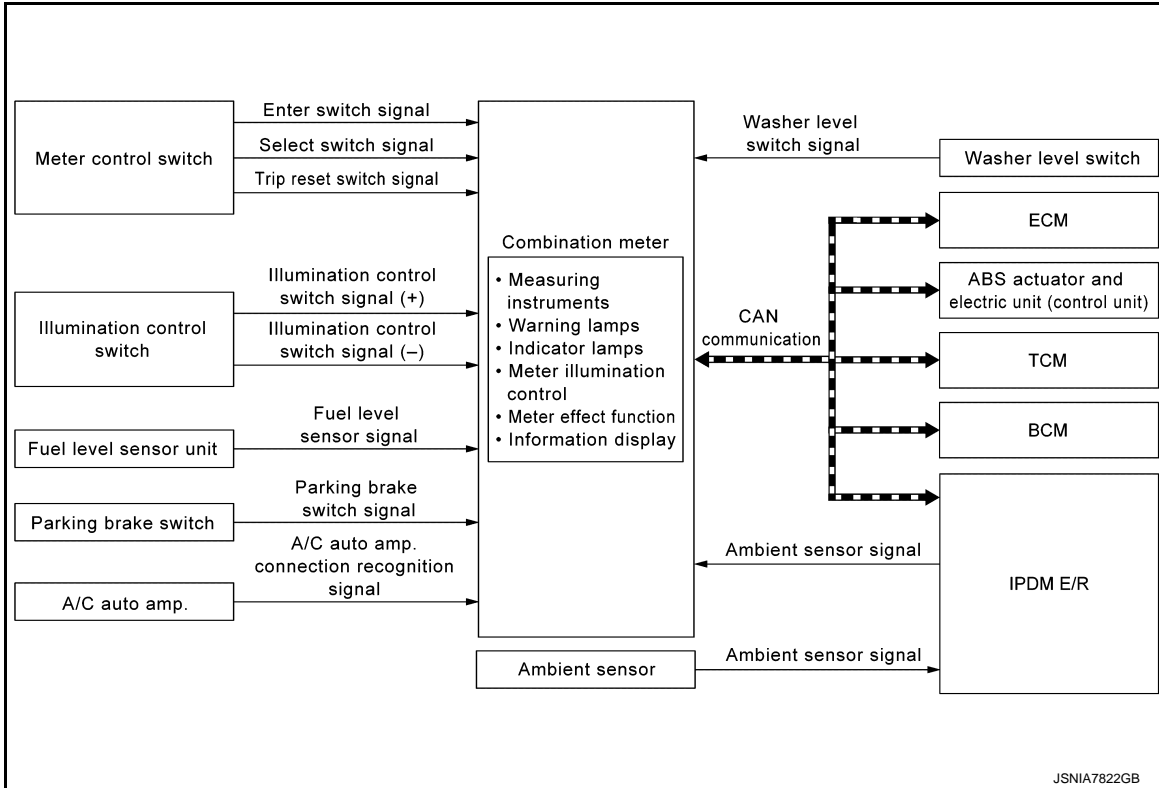

COMBINATION METER INPUT SIGNAL (CAN COMMUNICATION SIGNAL)

Transmit unit	Signal name
ABS actuator and electric unit (control unit)	Vehicle speed signal
BCM	Position light request signal
	Door switch signal
	Door lock/unlock status signal
	Meter display signal
	Low tire pressure warning lamp signal
	Dimmer signal
TCM	Starter relay status signal
	Shift position signal
ECM	Engine speed signal
	Engine coolant temperature signal
	Fuel consumption monitor signal
	Fuel filler cap warning display signal
	Oil pressure warning lamp signal
	Engine status signal

DESCRIPTION

Combination Meter

METER SYSTEM

< SYSTEM DESCRIPTION >

- The combination meter receives necessary signals from each unit, switch, and sensor to control the following functions.
 - Measuring instruments
 - Warning lamps
 - Indicator lamps
 - Meter illumination control
 - Meter effect function
 - Information display
- The combination meter incorporates a buzzer function that sounds an audible alarm with the integrated buzzer device. Refer to [WCS-4, "Combination Meter"](#) for further details.
- The combination meter includes an on board diagnosis function.
- The combination meter can be diagnosed with CONSULT.

METER CONTROL FUNCTION LIST

	System	Description	Reference
Measuring instruments	Speedometer	Indicates vehicle speed.	MWI-15, "SPEEDOMETER : System Description"
	Tachometer	Indicates engine speed.	MWI-15, "TACHOMETER : System Description"
	Engine coolant temperature gauge	Indicates engine coolant temperature.	MWI-15, "ENGINE COOLANT TEMPERATURE GAUGE : System Description"
	Fuel gauge	Indicates fuel level.	MWI-16, "FUEL GAUGE : System Description"
Warning lamp/indicator lamp	Oil pressure warning lamp	The warning lamp turns ON or turns OFF, according to engine hydraulic pressure.	MWI-16, "OIL PRESSURE WARNING LAMP : System Description"
	Master warning lamp	Turns ON/OFF in synchronization with a warning indicated on the information display.	MWI-17, "MASTER WARNING LAMP : System Description"
Meter illumination control	Meter illumination control function	Controls the back light of combination meter.	MWI-17, "METER ILLUMINATION CONTROL : System Description"
Meter effect function	Engine-start effect function	Controls pointers of combination meter and meter illumination at engine start to produce illumination effects.	MWI-19, "METER EFFECT FUNCTION : System Description"
	Driver welcome function	Controls meter illumination to produce illumination effects when getting in the vehicle.	

METER SYSTEM

< SYSTEM DESCRIPTION >

System		Description	Reference		
Information display	Odo/trip meter		Displays mileage.	A	
	Shift position indicator		Displays shift position.		
	Trip computer	Current fuel consumption		Displays current fuel consumption.	B
		Average fuel consumption		Displays average fuel consumption.	
		Distance to empty		Displays distance to empty.	C
		Average vehicle speed		Displays average vehicle speed.	
		Travel time		Displays travel time.	D
		Travel distance		Displays mileage.	
		Ambient temperature		Displays ambient temperature.	
	Interrupt indication	Warning	Door open warning	Warns when a door is open.	E
			Parking brake release warning	Warns if traveling when the parking brake is under operating condition.	
			Low fuel warning	Warns when being low on fuel.	F
			Low washer fluid warning	Displayed/Hidden, depending on washer fluid level.	G
			Fuel filler cap warning	Receives fuel filler cap warning display signal and displays warning.	
			Low tire pressure warning	Receives low tire pressure warning lamp signal and displays warning.	H
			NO KEY warning	Receives meter display signal and displays warning.	I
		Alert	Travel time	Causes an interrupt when exceeding randomly set time.	J
			Low ambient temperature	Causes an interrupt when ambient temperature reaches below 3°C (37°F).	
		Maintenance	Tire	Causes an interrupt when exceeding randomly set distance.	K
			Oil filter	Causes an interrupt when exceeding randomly set distance.	
Engine oil			Causes an interrupt when exceeding randomly set distance.	L	
Other			Causes an interrupt when exceeding randomly set distance.		
Meter illumination level		Indicates the brightness of the meter illumination in stages.	M		

[MWI-21, "INFORMATION DISPLAY : System Description"](#)

MWI

O

P

METER SYSTEM

< SYSTEM DESCRIPTION >

System			Description	Reference	
Information display	Setting	Alert	Timer	Allows the user to set a display time for "Travel time".	MWI-21, "INFORMATION DISPLAY : System Description"
			ICY	Allows the ON/OFF setting of the low ambient temperature (alert) function.	
		Maintenance	Tire	Alerts when reaching mileage set in "SETTING".	
			Filter	Alerts when reaching mileage set in "SETTING".	
			Oil	Alerts when reaching mileage set in "SETTING".	
			Other	Alerts when reaching mileage set in "SETTING".	
		Options	Language	Allows the user to set language for information display.	
			Unit	Allows unit settings.	
			Effects	Allows the ON/OFF setting of the engine-start effect function.	

METER SYSTEM

< SYSTEM DESCRIPTION >

METER SYSTEM : Circuit Diagram

INFOID:000000011324083

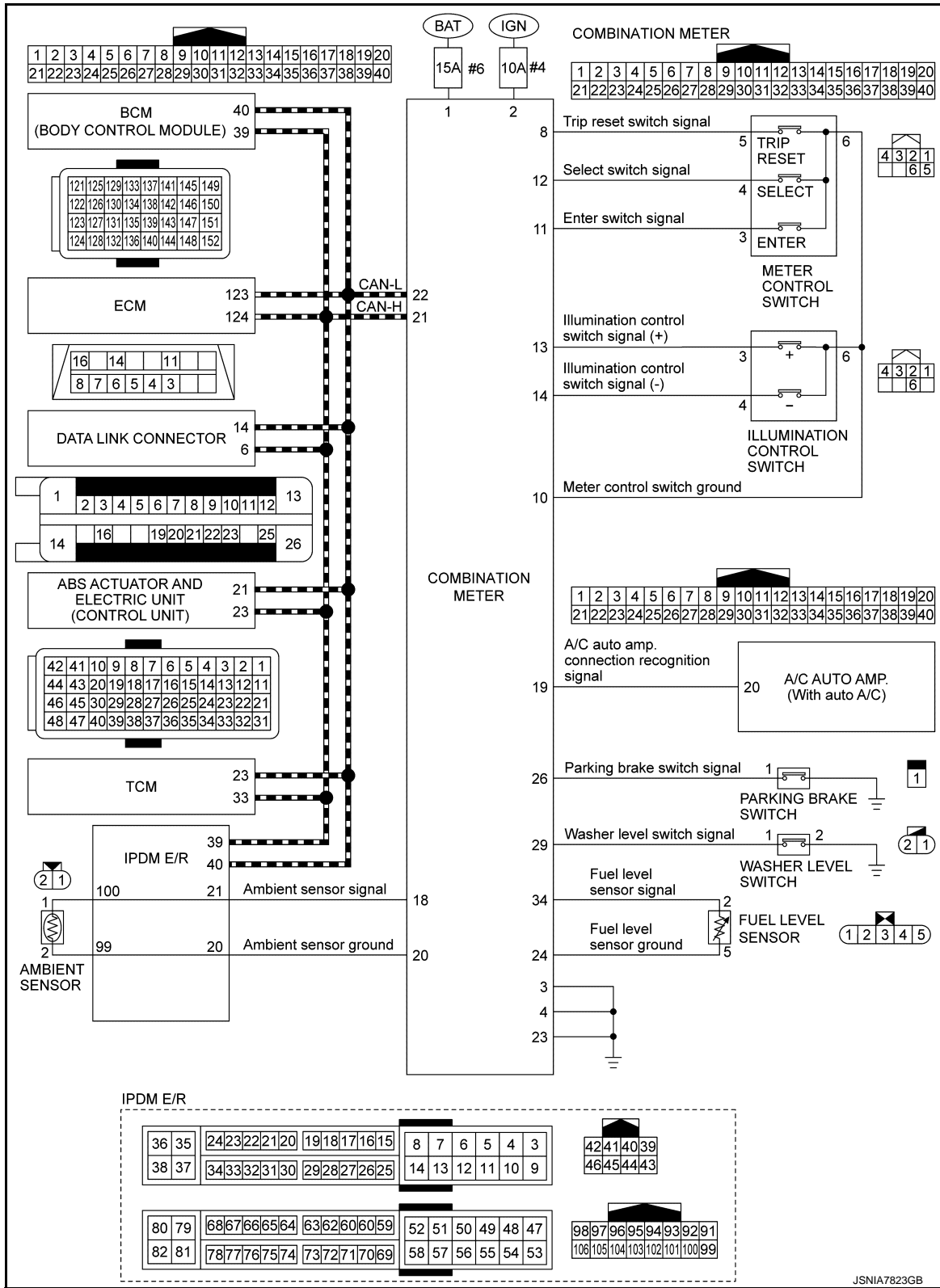

A
B
C
D
E
F
G
H
I
J
K
L
M
N
O
P

MWI

METER SYSTEM : Fail-Safe

INFOID:000000011515075

FAIL-SAFE

The combination meter activates the fail-safe control if CAN communication with each unit is malfunctioning.

METER SYSTEM

< SYSTEM DESCRIPTION >

Function		Specifications	
Speedometer		Reset to zero by suspending communication.	
Tachometer			
Engine coolant temperature gauge			
Illumination control		When suspending communication, changes to nighttime mode.	
Information display	Odo/trip meter	An indicated value is maintained at communications blackout.	
	Shift position indicator	The display turns OFF by suspending communication.	
	Interrupt indication	Door open warning	The display turns OFF by suspending communication.
		Fuel filler cap warning	
		Low tire pressure warning	
	Trip computer	Current fuel consumption	<ul style="list-style-type: none"> When reception time of an abnormal signal is 2 seconds or less, the last received datum is used for calculation to indicate the result. When reception time of an abnormal signal is more than two seconds, the last calculation results are indicated.
		Average fuel consumption	
		Distance to empty	
		Average vehicle speed	
		Travel distance	
Buzzer		The buzzer turns OFF by suspending communication.	
Warning lamp/indicator lamp	ABS warning lamp	The lamp turns ON by suspending communication.	
	VDC warning lamp		
	Brake warning lamp		
	EPS warning lamp		
	Malfunction indicator lamp		
	Low tire pressure warning lamp	The lamp blinking caused by suspending communication.	
	High beam indicator lamp	The lamp turns OFF by suspending communication.	
	Turn signal indicator lamp		
	VDC OFF indicator lamp		
	O/D OFF indicator lamp		
	Position lamp indicator lamp		
	CRUISE indicator lamp		
	Oil pressure warning lamp		
	BSW warning lamp		
Key warning lamp			

SPEEDOMETER

METER SYSTEM

< SYSTEM DESCRIPTION >

SPEEDOMETER : System Description

INFOID:000000011324085

SYSTEM DIAGRAM

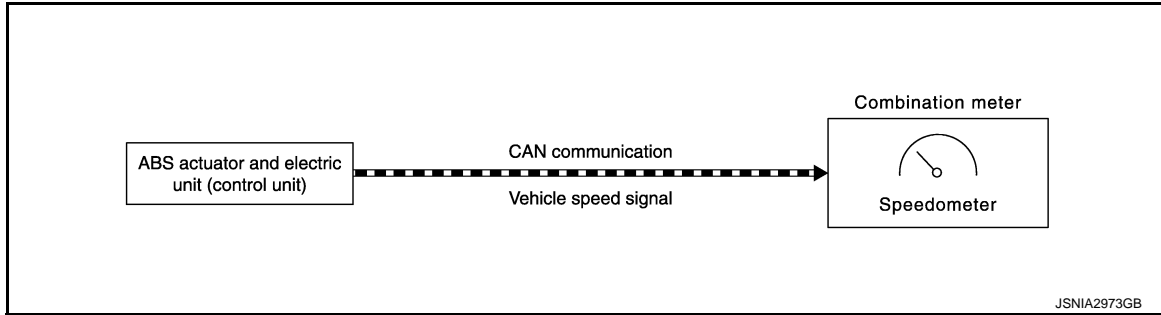

DESCRIPTION

- The ABS actuator and electric unit (control unit) converts the rectangular wave signal provided by the wheel sensor to a vehicle speed signal and transmits it to the combination meter via CAN communication.
- The combination meter indicates the vehicle speed to the speedometer according to the vehicle speed signal received via CAN communication.

TACHOMETER

TACHOMETER : System Description

INFOID:000000011324086

SYSTEM DIAGRAM

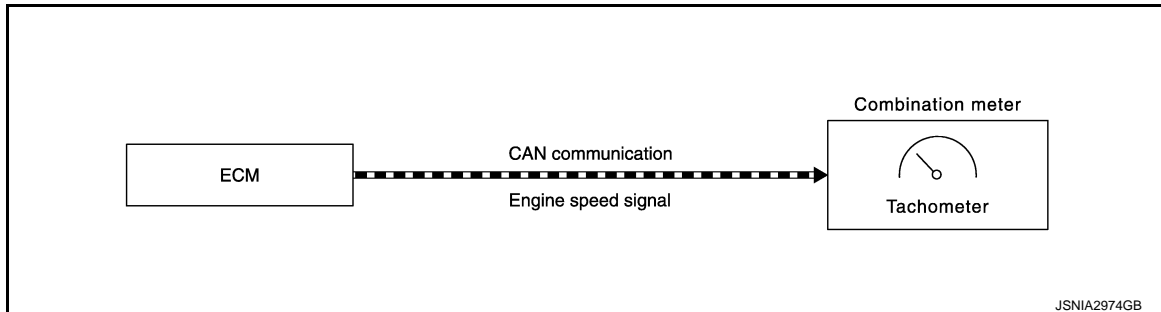

DESCRIPTION

- ECM converts the pulse signal provided by the crankshaft position sensor to an engine speed signal and transmits it to the combination meter via CAN communication.
- The combination meter indicates the engine speed to the tachometer according to the engine speed signal received via CAN communication.

ENGINE COOLANT TEMPERATURE GAUGE

ENGINE COOLANT TEMPERATURE GAUGE : System Description

INFOID:000000011324087

SYSTEM DIAGRAM

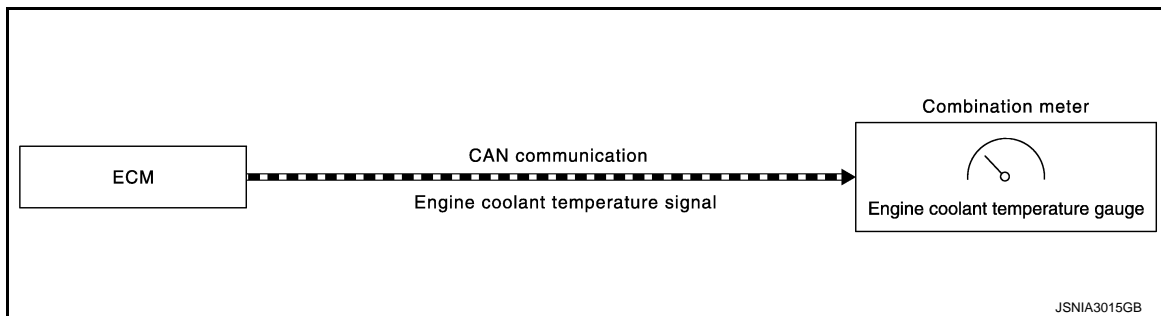

DESCRIPTION

- ECM reads the engine coolant temperature signal from the engine coolant temperature sensor and transmits the signal to the combination meter via CAN communication.

A
B
C
D
E
F
G
H
I
J
K
L
M

MWI

O
P

METER SYSTEM

< SYSTEM DESCRIPTION >

- The combination meter indicates the engine coolant temperature to the engine coolant temperature gauge according to the engine coolant temperature signal received via CAN communication.

FUEL GAUGE

FUEL GAUGE : System Description

INFOID:000000011324088

SYSTEM DIAGRAM

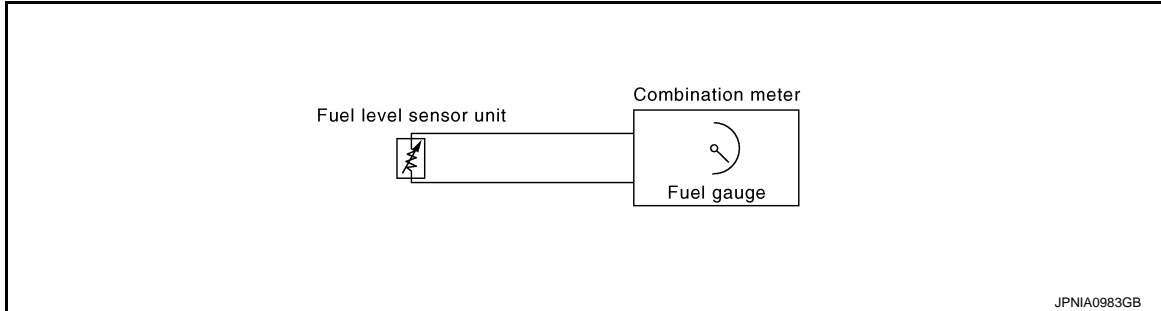

DESCRIPTION

Control Outline

The combination meter reads the fuel level sensor signal from the fuel level sensor unit and indicates the fuel level to the fuel gauge.

Refuel Control

The combination meter accelerates the fuel gauge if the all conditions listed below are met, or the ignition switch is ON from OFF.

- Ignition switch is ON position.
- The vehicle is not moving.
- The fuel level change by 15 ℓ (4 US gal, 3-1/4 Imp gal) or more.

OIL PRESSURE WARNING LAMP

OIL PRESSURE WARNING LAMP : System Description

INFOID:000000011324089

SYSTEM DIAGRAM

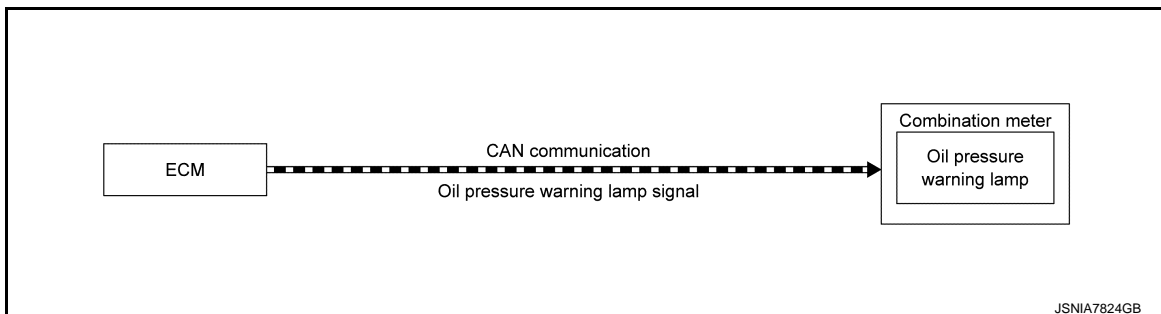

DESCRIPTION

The combination meter turns the oil pressure warning lamp ON when receiving ECM to the oil pressure warning lamp signal via CAN communication. For details, refer to [EC-25. "Engine Oil Pressure Sensor"](#).

MASTER WARNING LAMP

METER SYSTEM

< SYSTEM DESCRIPTION >

MASTER WARNING LAMP : System Description

INFOID:000000011324090

SYSTEM DIAGRAM

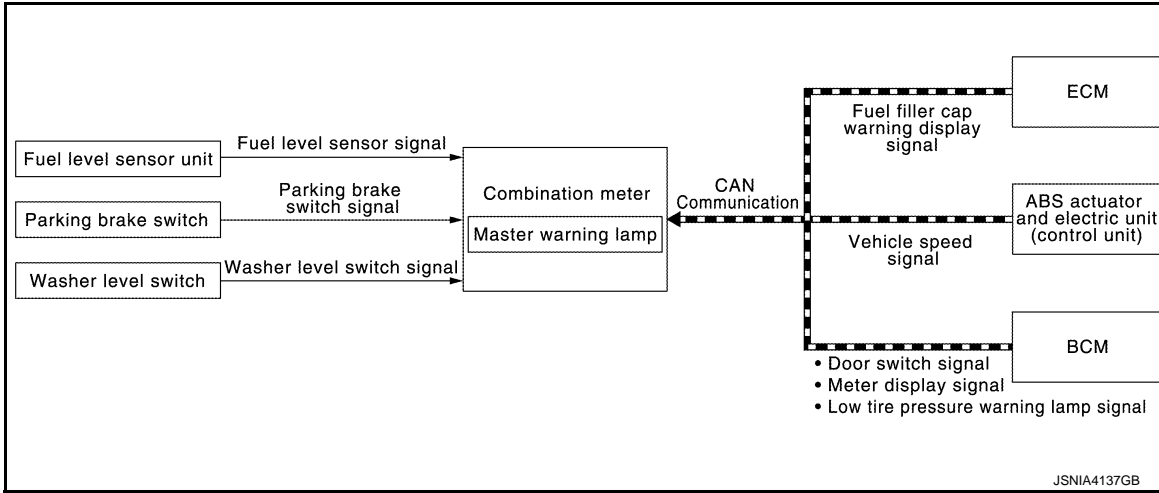

DESCRIPTION

When receiving a signal from each unit, switch, or sensor, the combination meter turns ON/OFF the master warning lamp in synchronization with the following warnings on the information display.

- Door open warning
- Parking brake release warning
- Low fuel warning
- Low washer fluid warning
- NO KEY warning
- Low tire pressure warning
- Fuel filler cap warning

NOTE:

For details on warnings displayed on the information display, refer to [MWI-21. "INFORMATION DISPLAY : System Description"](#).

METER ILLUMINATION CONTROL

METER ILLUMINATION CONTROL : System Description

INFOID:000000011324091

SYSTEM DIAGRAM

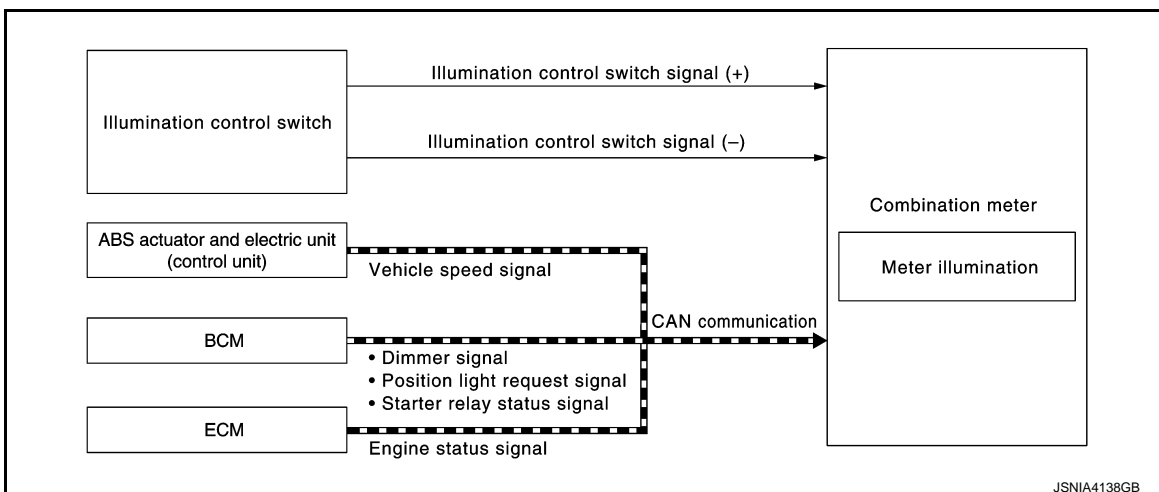

DESCRIPTION



Meter Illumination On/off Control Function

- Combination meter turns ON meter illumination when the following condition is satisfied:
 - Ignition switch ON
- Combination meter turns OFF meter illumination when any of the following condition is satisfied:

METER SYSTEM

< SYSTEM DESCRIPTION >

- During a crank with vehicle speed less than 1 km/h (0.6 MPH)
- Ignition switch OFF or ACC
- The combination meter receives the following signals to control meter illumination.

Signal name	Signal path
Ignition signal	—
Engine status signal	ECM  Combination meter
Vehicle speed signal	ABS actuator and control unit (control unit)  Combination meter
Starter relay status signal	BCM  Combination meter

Meter Illumination Control Function

- Combination meter controls meter illumination, based on the following signal.
- Dimmer signal (for U.S.A)
- Position light request signal (for Canada)
- The combination meter switches mode between Daytime mode and Nighttime mode, according to the following conditions.



Condition		Meter illumination		
		For U.S.A		For Canada
Combination switch (lighting switch)	1ST or 2ND position	Outdoor: Bright*	Daytime mode	Nighttime mode
		Outdoor: Dark*	Nighttime mode	Nighttime mode
	AUTO POSITION	Outdoor: Bright*	Daytime mode	Daytime mode
		Outdoor: Dark*	Nighttime mode	Nighttime mode
Off		Daytime mode	Daytime mode	

*: For further information, refer to [INL-17. "AUTO LIGHT ADJUSTMENT SYSTEM : System Description"](#).

- The operation of the illumination control switch allows the brightness adjustment of meter illumination.

Meter illumination	The number of adjustable steps
Daytime	22 step
Nighttime	22 step

Signal Path

Signal name	Signal source
Ignition signal	—
Dimmer signal (for U.S.A)	BCM  Combination meter
Position light request signal (for Canada)	BCM  Combination meter

METER EFFECT FUNCTION

METER SYSTEM

< SYSTEM DESCRIPTION >

METER EFFECT FUNCTION : System Description

INFOID:000000011324092

SYSTEM DIAGRAM

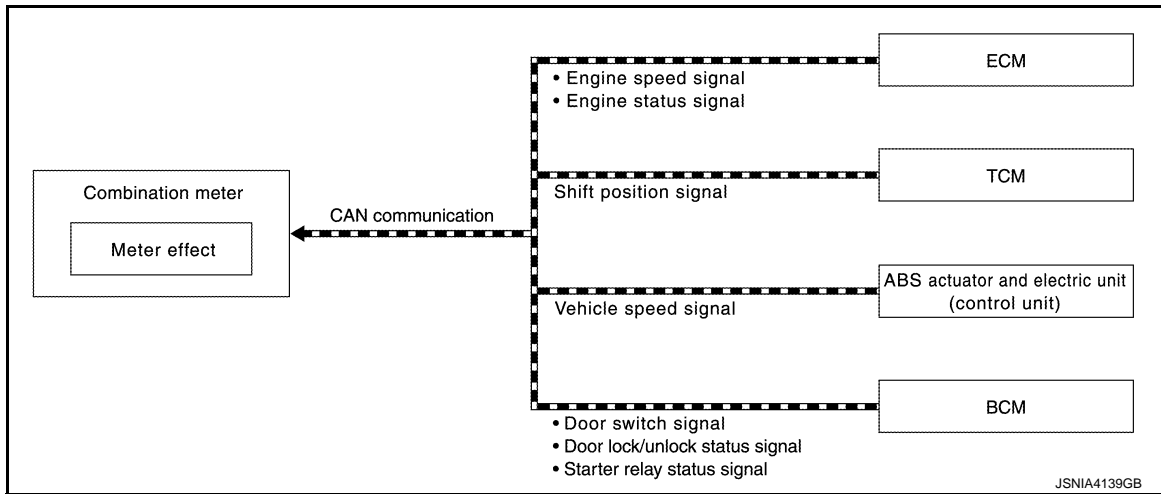

DESCRIPTION

Engine-start Effect Function

When recognizing an engine start, the combination meter controls the following items for producing the effect.

- Speedometer
- Tachometer
- Engine coolant temperature gauge
- Fuel gauge
- Meter illumination

Meter and Illumination Operations During Engine-start Effect

The combination meter controls the following items during the engine-start effect.

Control item	Operation
Speedometer	Sweeps the pointer.
Tachometer	Sweeps the pointer.
Engine coolant temperature gauge	Stops the pointer.
Fuel gauge	Stops the pointer.
Pointer	Turns on the illumination at the normal brightness level.
Printed area of the dial	Turns on the illumination at the effect level.
Illumination ring	Increases the brightness to the effect level in stages.
Information display (Dot matrix display and segment display)	Turns on the illumination at the normal brightness level.

NOTE:

The pointers are stopped and illumination is turned off while cranking the engine.

Engine Start Judgement

The combination meter judges "engine-start" and activates the engine-start effect only once when the following operational conditions are all satisfied.

Operational condition	
Ignition switch	ON position
Vehicle speed	Less than 1 km/h (0.6 MPH)
Engine state	Other than the time of cranking the engine
	500 rpm or more

METER SYSTEM

< SYSTEM DESCRIPTION >





Operational condition	
Shift position	"P"
Information display (SETTING)	The setting of "EFFECT" is "ON"

NOTE:

ENGINE-START EFFECT exits when any of the above operational conditions is cancelled during the engine-start effect.

Signal Path

The combination meter judges "engine-start", according to the following signals and activates the engine-start effect function.

Signal name	Signal source
Ignition signal	—
Starter relay status signal	BCM  Combination meter
Engine speed signal	ECM  Combination meter
Engine status signal	
Vehicle speed signal	ABS actuator and electric unit (control unit)  Combination meter
Shift position signal	TCM  Combination meter

NOTE:

The engine-start effect function ends if any one of the above conditions is lost during the activation of this function.

Driver Welcome Function



BCM transmits a meter ring illumination request signal to the illumination meter when all the following operational conditions are satisfied. When receiving the meter ring illumination request signal from BCM via CAN communication, the combination meter increases illumination brightness of the combination meter to the set brightness level in stages. After a certain period of time, the meter illumination gradually dims to be turned OFF.

Operational condition	
Ignition switch	LOCK position
Driver side door	Open → Close*

*: Close the driver side door with the intelligent key left inside the vehicle.

Signal Path

The combination meter receives the following signals to control meter ring illumination.

Signal name	Signal source
Ignition signal	—
Door switch signal (driver)	BCM  Combination meter
Door lock/unlock status signal	BCM  Combination meter

METER SYSTEM

< SYSTEM DESCRIPTION >

Timing Chart

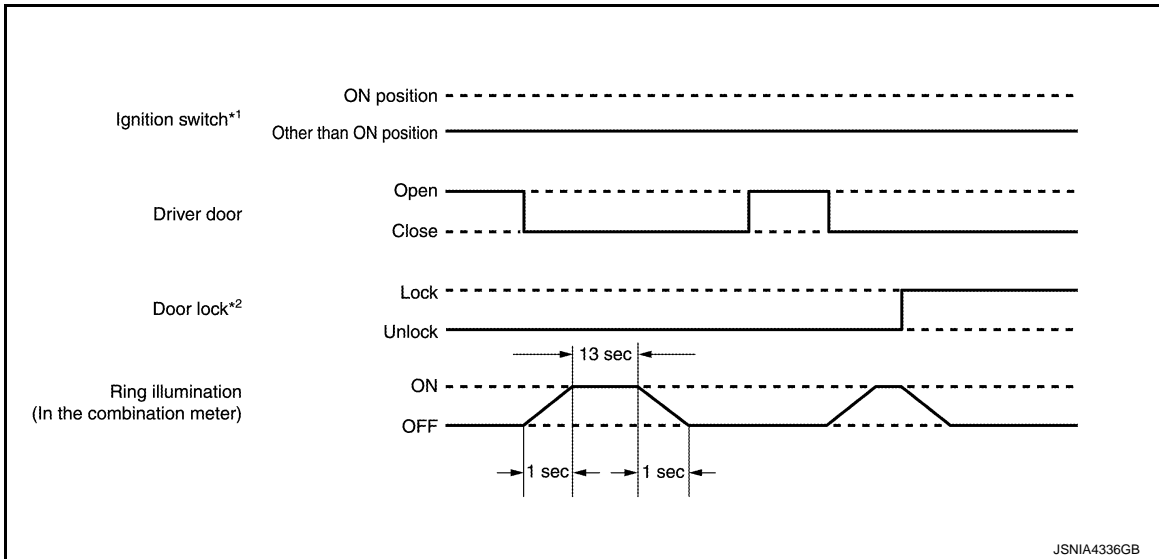

- *1: The driver welcome function is not performed when the driver's door is opened/closed for the first time after turning the ignition switch from ON to LOCK.
- *2: The operation of the following switches allows the door to be locked/unlocked.
 - Door lock/unlock button of the Intelligent Key
 - Door request switch
 - Door key cylinder switch
 - Door lock and unlock switch

INFORMATION DISPLAY : System Description

INFOID:000000011324093

SYSTEM DIAGRAM

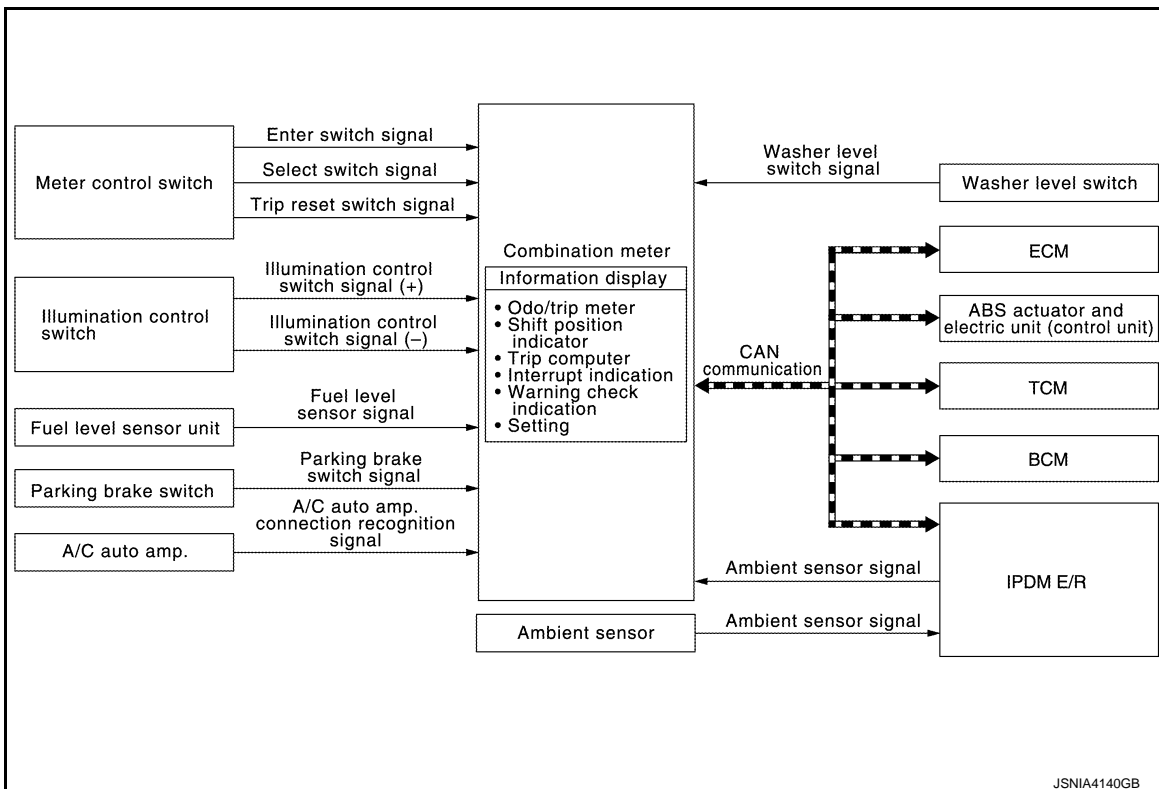

DESCRIPTION

- The combination meter receives signals necessary for controlling the operation of the information display from each unit, sensor and switch.

METER SYSTEM

< SYSTEM DESCRIPTION >

- The combination meter incorporates a trip computer that displays the warning/information according to the information received from each unit, sensor and switch.
- The combination meter shows the following functions on the information display.
 - Odo/trip meter
 - Shift position indicator
 - Trip computer
 - Interrupt indication
 - Warning check indication
 - Setting
- The vehicle information display is comprised of dot matrix information display (1) and segment information display (2). Each display shows the items listed below.

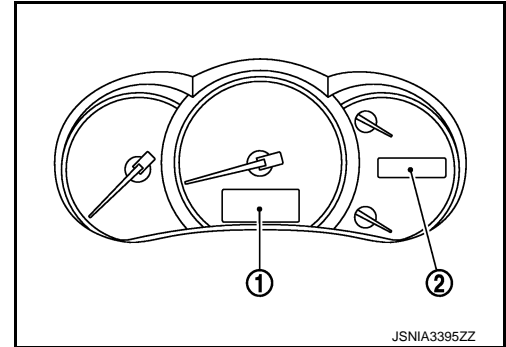

METER SYSTEM

< SYSTEM DESCRIPTION >

Display	Display item				
Dot matrix information display	Interrupt indication	Warning	Door open warning	A	
			Parking brake release warning	B	
			Low fuel warning	C	
			Low washer warning		
			Fuel filler cap warning		
			Low tire pressure warning		
			NO KEY warning	D	
		Alert	Travel time		
			ICY	E	
		Maintenance	Tire		
			Oil filter		
			Engine oil	F	
			Other		
	Meter illumination level				
	Trip computer			Current fuel consumption	G
				Average fuel consumption	
				Average vehicle speed	
				Travel time	H
				Travel distance	
				Distance to empty	I
				Ambient temperature	
Setting				Alert	Timer
	ICY				
	Maintenance	Tire			
		Oil filter			
		Engine oil	K		
		Other			
	Options	Language	L		
		Unit			
		Effect	M		
	Segment information display	<ul style="list-style-type: none"> • Shift position indicator • Odo/trip meter 			

ODO/TRIP METER

The combination meter calculates mileage, based on the following signals and displays the mileage on the information display.

Signal name	Signal Path
Ignition signal	—
Vehicle speed signal	ABS actuator and electric unit (control unit)  Combination meter

SHIFT POSITION INDICATOR

The combination meter receives the shift position signal from TCM via CAN communication, and displays the shift position to the shift position indicator.

METER SYSTEM



< SYSTEM DESCRIPTION >

Signal name	Signal Path
Shift position signal	TCM  → Combination meter

TRIP COMPUTER

Current Fuel Consumption

The combination meter calculates current fuel consumption based on the following signals, and the calculated value is displayed on the information display.



Signal name	Signal Path
Ignition signal	—
Fuel consumption monitor signal	ECM  → Combination meter
Vehicle speed signal	ABS actuator and electric unit (control unit)  → Combination meter

NOTE:

- Current fuel consumption on the information display is updated approximately every 0.1 seconds.
- Current fuel consumption on the information display shows 30 l/100km (0 mpg) when vehicle speed is 0 km/h (0 MPH).

Average Fuel Consumption

The combination meter calculates average fuel consumption based on the following signals, and the calculated value is displayed on the information display.



Signal name	Signal Path
Ignition signal	—
Fuel consumption monitor signal	ECM  → Combination meter
Vehicle speed signal	ABS actuator and electric unit (control unit)  → Combination meter

NOTE:

- Average fuel consumption on the information display is updated approximately every 30 seconds.
- Soon after a reset or when the ignition switch is turned ON after battery installation, “—” is displayed for 30 seconds and approximately 500 m (0.31 mile).

Distance to Empty

The combination meter calculates distance to empty based on the following signals, and the calculated value is displayed on the information display.

Signal name	Signal Path
Ignition signal	—
Fuel level sensor signal	Fuel level sensor unit  → Combination meter
Fuel consumption monitor signal	ECM  → Combination meter
Vehicle speed signal	ABS actuator and electric unit (control unit)  → Combination meter

NOTE:

- Distance to empty on the information display is updated approximately every 30 seconds.
- When the ignition switch is turned ON, “—” is displayed for 30 seconds because stored values are deleted after battery installation.
- The indicated values may not match each other when refueling with the ignition switch ON.

Average Vehicle Speed

METER SYSTEM

< SYSTEM DESCRIPTION >

The combination meter calculates average vehicle speed based on the following signals, and the calculated value is displayed on the information display.

Signal name	Signal Path
Ignition signal	—
Vehicle speed signal	ABS actuator and electric unit (control unit)  Combination meter

NOTE:

- Average vehicle speed on the information display is updated approximately every 30 seconds.
- Soon after a reset or when the ignition switch is turned ON after battery installation, “—” is displayed for 30 seconds.

Travel Time

The combination meter measures and displays travel time (ignition switch ON time).





Travel Distance

The combination meter calculates mileage, based on the following signals and displays the mileage on the information display.

Signal name	Signal Path
Ignition signal	—
Vehicle speed signal	ABS actuator and electric unit (control unit)  Combination meter

Ambient Temperature

The combination meter calculates ambient temperature based on the following signals, and the calculated value is displayed on the information display.

Signal name	Signal Path
Ignition signal	—
Ambient sensor signal	Ambient sensor  IPDM E/R  Combination meter
A/C auto amp. recognition signal (with auto A/C)	A/C auto amp.  Combination meter
Vehicle speed signal	ABS actuator and electric unit (control unit)  Combination meter

NOTE:

- The indicated temperature is corrected based on an ignition signal, ambient temperature detected by the ambient sensor, and vehicle speed signal. The indicated temperature is not raised under vehicle speed less than 20 km/h (12 MPH).
- The ambient sensor input value that is displayed on “Data Monitor” of CONSULT is the value before the correction. It may not match the indicated temperature on the information display.
- Depending on engine heat or heat on the road surfaces, an ambient temperature may be indicated higher than actual one.

INTERRUPT INDICATION

- The combination meter displays an interrupt regarding a warning, alert, and maintenance on the information display, based on signals received from each unit and switch.
- When conditions are satisfied, the normal screen switches to a warning screen to display an interrupt.

Door Open Warning

- When all the following operating conditions are satisfied, the combination meter displays a door open warning on the information display by an interrupt.

Operating condition	
Ignition switch	ON
Door	Any door is open



A
B
C
D
E
F
G
H
I
J
K
L
M
N
O
P

MWI

METER SYSTEM

< SYSTEM DESCRIPTION >

- The combination meter judges showing/hiding of “door open warning”, according to the signals below:



Signal name	Signal Path
Ignition signal	—
Door switch signal	Door switch  BCM  Combination meter

Parking Brake Release Warning

- When all the following operating conditions are satisfied, the combination meter displays a parking brake release warning on the information display by an interrupt.

Operating condition	
Ignition switch	ON
Parking brake	Applied
Vehicle speed	7 km/h (4.3 MPH) or more

- The combination meter judges showing/hiding of “parking brake release warning”, according to the signals below:

Signal name	Signal Path
Ignition signal	—
Parking brake switch signal	Parking brake switch  Combination meter
Vehicle speed signal	ABS actuator and electric unit (control unit)  Combination meter

Low Fuel Warning

- When all the following operating conditions are satisfied, the combination meter displays a low fuel warning on the information display by an interrupt.

Operating condition	
Ignition switch	ON
Fuel remaining quantity*	Approximately 11.4 ℓ (3 US gal, 2 - 1/2 Imp gal) or less (including fuel remained)

*: With the vehicle in a horizontal position

- The combination meter judges showing/hiding of “low fuel warning”, according to the signals below:

Signal name	Signal Path
Ignition signal	—
Fuel level sensor signal	Fuel level sensor  Combination meter

Low washer fluid warning

- When all the following operating conditions are satisfied, the combination meter displays a low washer fluid warning on the information display by an interrupt.

Operating condition	
Ignition switch	ON
Washer level switch	Decrease in fluid level (washer level switch ON for 180 seconds or more)

METER SYSTEM

< SYSTEM DESCRIPTION >

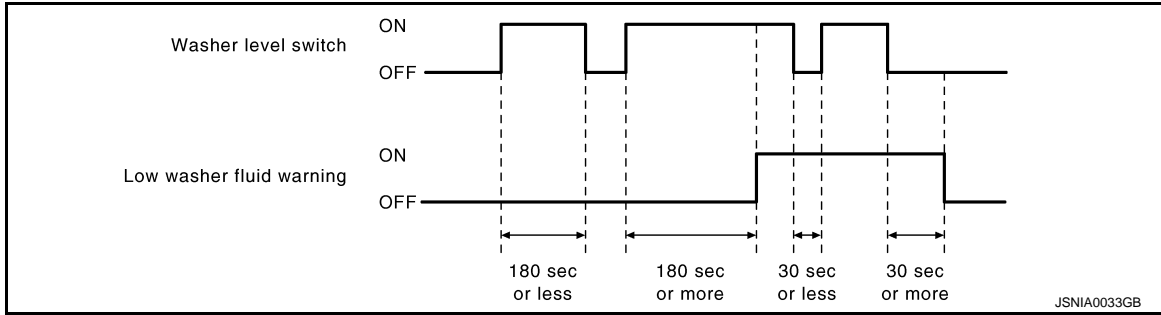

- The combination meter judges showing/hiding of “low washer fluid warning”, according to the signals below:

Signal name	Signal Path
Ignition signal	—
Washer level switch signal	Washer level switch → Combination meter

Fuel Filler Cap Warning

- The combination meter judges showing/hiding of “fuel filler cap warning”, according to the signals below:

Signal name	Signal Path
Ignition signal	—
Fuel filler cap warning display signal	ECM  → Combination meter

- For further information, refer to [EC-55. "FUEL FILLER CAP WARNING SYSTEM : System Description"](#).

Low Tire Pressure Warning

- The combination meter judges showing/hiding of “low tire pressure warning”, according to the signals below:

Signal name	Signal Path
Ignition signal	—
Low tire pressure warning lamp signal	BCM  → Combination meter

- For further information, refer to [WT-8. "System Description"](#).

NO KEY Warning

- The combination meter judges showing/hiding of “NO KEY warning”, according to the signals below:

Signal name	Signal Path
Ignition signal	—
Meter display signal	BCM  → Combination meter

- For further information, refer to [DLK-47. "WARNING FUNCTION : System Description"](#).

Travel Time (Alert)

- When all the following operating conditions are satisfied, the combination meter displays a travel time on the information display by an interrupt.

Operating condition	
Ignition switch	Switch-ON time

- The combination meter judges showing/hiding of “travel time”, according to the signal below:

METER SYSTEM

< SYSTEM DESCRIPTION >

Signal name	Signal Path
Ignition signal	—

Low Ambient Temperature (Alert)

- When all the following operating conditions are satisfied, the combination meter displays a low ambient temperature on the information display by an interrupt.

Operating condition	
Ignition switch	ON
Ambient temperature	3 °C (37 °F) or less
information display	“ON” is selected in “SETTING”

- The combination meter judges showing/hiding of “low ambient temperature”, according to the signals below:

Signal name	Signal Path
Ignition signal	—
Ambient sensor signal	Ambient sensor → IPDM E/R → Combination meter

Tire (Maintenance)

- When all the following operating conditions are satisfied, the combination meter displays a tire warning on the information display by an interrupt.

Operating condition	
Ignition switch	ON
Mileage	More than value set in “SETTING”

- The combination meter judges showing/hiding of “tire warning”, according to the signals below:

Signal name	Signal Path
Ignition signal	—
Vehicle speed signal	ABS actuator and electric unit (control unit)  → Combination meter

Oil Filter (Maintenance)

- When all the following operating conditions are satisfied, the combination meter displays a oil filter warning on the information display by an interrupt.

Operating condition	
Ignition switch	ON
Mileage	More than value set in “SETTING”

- The combination meter judges showing/hiding of “oil filter warning”, according to the signals below:

Signal name	Signal Path
Ignition signal	—
Vehicle speed signal	ABS actuator and electric unit (control unit)  → Combination meter

Engine Oil (Maintenance)

- When all the following operating conditions are satisfied, the combination meter displays a engine oil warning on the information display by an interrupt.

METER SYSTEM

< SYSTEM DESCRIPTION >

Operating condition	
Ignition switch	ON
Mileage	More than value set in "SETTING"

- The combination meter judges showing/hiding of "engine oil warning", according to the signals below:

Signal name	Signal Path
Ignition signal	—
Vehicle speed signal	ABS actuator and electric unit (control unit)  → Combination meter

Other (Maintenance)

- When all the following operating conditions are satisfied, the combination meter displays a other warning on the information display by an interrupt.

Operating condition	
Ignition switch	ON
Mileage	More than value set in "SETTING"

- The combination meter judges showing/hiding of "other warning", according to the signals below:

Signal name	Signal Path
Ignition signal	—
Vehicle speed signal	ABS actuator and electric unit (control unit)  → Combination meter

Meter Illumination Level Indication

When receiving the following signals, the combination meter causes an interrupt on the information display to indicate an illumination level.

Signal name	Signal Path
Ignition signal	—
Illumination control switch signal (+)	Illumination control switch  → Combination meter
Illumination control switch signal (-)	

WARNING CHECK INDICATION

- The combination meter can cause an interrupt on the information display to indicate a warning, based on signals received from each unit and switch.
- The indicated warning can be checked with "WARNING" during the satisfaction of an interrupt indication condition for each warning.

SETTING

Warning indication timing and time can be set.

Alert

Setting values for travel time, and low ambient temperature can be adjusted to meet the user's needs.

Setting item		Setting range	Setting unit
Alert	Timer	No setting, 0.5 h - 6 h	0.5 h
	ICY	ON/OFF	—

Maintenance

Setting values for engine oil, oil filter, tire, and other maintenance items can be adjusted to meet the user's needs.

A
B
C
D
E
F
G
H
I
J
K
L
M
O
P

MWI

METER SYSTEM

< SYSTEM DESCRIPTION >

Setting item		Setting range
Maintenance	Engine oil	No setting, 500 km - 30,000 km (No setting, 250 mile - 18,500 mile)
	Oil filter	No setting, 500 km - 30,000 km (No setting, 250 mile - 18,500 mile)
	Tire	No setting, 500 km - 30,000 km (No setting, 250 mile - 18,500 mile)
	Other	No setting, 500 km - 30,000 km (No setting, 250 mile - 18,500 mile)

Options

Setting values for language, unit, and effect items can be adjusted to meet the user's needs.

Setting item		
Options	Language	ENGLISH
		FRANCAISE
	Unit	miles, MPG, °F
		km, l/100 km, °C
Effect	ON/OFF	

Settings-reject Indication

- Regarding settings-reject indications, "SETTING CAN BE OPERATED WHEN STOPPED" is shown on the information display when indication conditions are satisfied.
- When reaching 5 km/h (3.1 MPH) after accelerating from a stopping condition, a settings-reject indication is displayed.
- When reaching less than 2 km/h (1.2 MPH) after decelerating from 5 km/h (3.1 MPH), a settings-reject indication is cancelled to allow settings.
- The combination meter judges a vehicle condition based on the following signals and displays a settings-reject indication on the information display.

Signal name	Signal Path
Ignition signal	—
Vehicle speed signal	ABS actuator and electric unit (control unit)  Combination meter

METER SYSTEM

< SYSTEM DESCRIPTION >

TIMING CHART

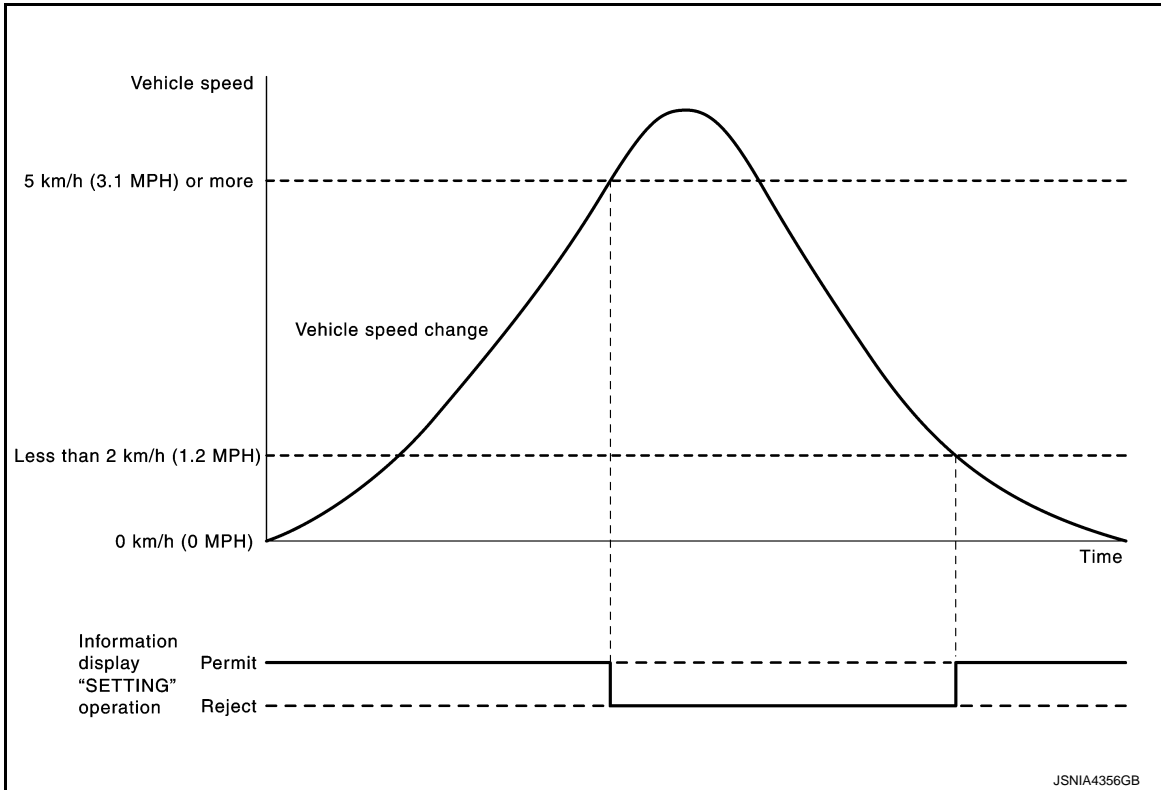

A
B
C
D
E
F
G
H
I
J
K
L
M

MWI

O
P

COMPASS

< SYSTEM DESCRIPTION >

COMPASS

System Description

INFOID:000000011324094

DESCRIPTION

- This electronic compass is able to display 8 primary directions: N, NE, E, SE, S, SW, W, NW.
- The inside mirror switch is used to operate the compass.

- 1 : Compass switch
- 2 : Compass display

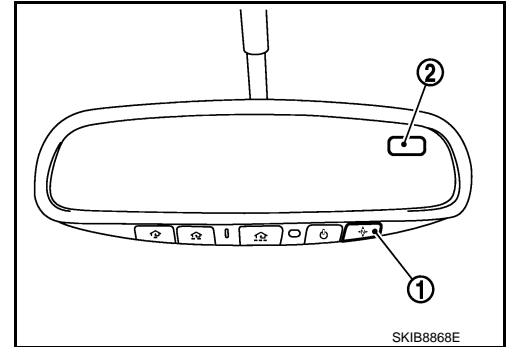

Switch Operation

Press	Compass is turned ON/OFF
Press and hold (for 3- 9 sec.)	Compass display turns to zone variation change mode
Press and hold (for more than 9 sec.)	Compass display turns to calibration mode

- All standard compasses determine direction relative to magnetic north, however, this electronic compass is designed to display direction relative to true north.
- The difference between magnetic north and true north varies from place to place across the surface of the earth.
- This electronic compass must be “told” approximately where it is on the earth’s surface so that the magnetic north reading can be properly converted into a true north display.
- To tell the electronic compass where it’s at, the earth is separated into numbered “Zone Variances”. The zone variance number in which the compass is to function must be entered into this electronic compass.
- Each zone is magnetically about 4.2° wide. Typically, anything under a 22.5° total zone change is not noticed on the electronic compass display. However, if a change over 22.5° occurs, a reading may be off by one or more primary directions.
- On long trips, the vehicle may leave its original zone and enter one or more new zones. Generally, you do not need to reset the compass zone if you travel between 3 or 4 zones, such as business travel or vacation. The typical driver will not notice any difference on the display within 3 or 4 zones. However, if the vehicle is “permanently” moved to a new location, it is recommended that the compass zone be reset.

OPERATION

< SYSTEM DESCRIPTION >

OPERATION

Switch Name and Function

INFOID:000000011324095

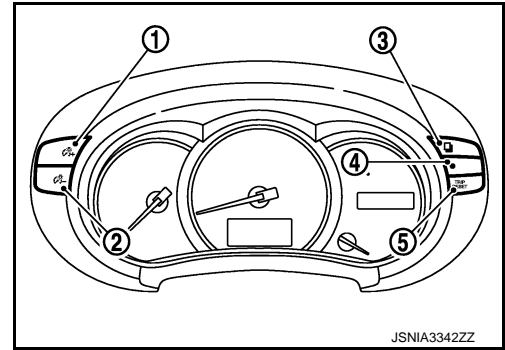

Switch name		Operation	Description
Illumination control switch	Illumination control switch (+) (1)	Press	An illuminance level of the back light of the combination meter can be adjusted.
	Illumination control switch (-) (2)		
Meter control switch	Enter switch (3)		<ul style="list-style-type: none"> The information display screen can be switched. The item indicated on the information display can be confirmed.
	Select switch (4)		When plural items are shown on the information display, a selected item can be changed to the other item.
	Trip reset switch (5)		<ul style="list-style-type: none"> The trip meter can be switched between A and B. Trip meter A/B can be reset by pressing and holding the trip reset switch.

A
B
C
D
E
F
G
H
I
J
K
L
M
N
O
P

MWI

DIAGNOSIS SYSTEM (COMBINATION METER)

< SYSTEM DESCRIPTION >

DIAGNOSIS SYSTEM (COMBINATION METER)

On Board Diagnosis Function

INFOID:000000011324096

ON BOARD DIAGNOSIS ITEM

The combination meter allows the following diagnosis items with the on-board diagnosis function.

Diagnosis item	
Drive circuit check	<ul style="list-style-type: none">• Speedometer• Tachometer• Engine coolant temperature gauge• Fuel gauge
LCD (liquid crystal display) check	Information display (dot matrix information display and segment information display)

METHOD OF STARTING

1. Turn ignition switch OFF.
2. While pressing the trip reset switch (1), turn ignition switch ON.

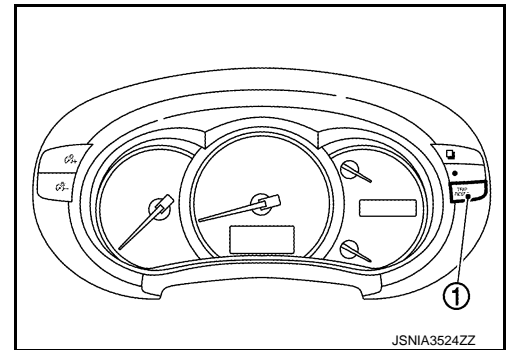

3. If the diagnosis function is activated with "trip A" displayed, the mileage on "trip A" is reset to "0000.0". (The same way for "trip B".)
4. Make sure that the trip meter displays "0000.0".
5. Press the trip reset switch at least 3 times. (Within 7 seconds after the ignition switch is turned ON.)
6. The combination meter is turned to self-diagnosis mode.
 - Speedometer, tachometer, engine coolant temperature gauge, and fuel gauge return to zero, simultaneously.
 - The dot matrix dots on the information display (dot matrix information display) (1) blink alternately.

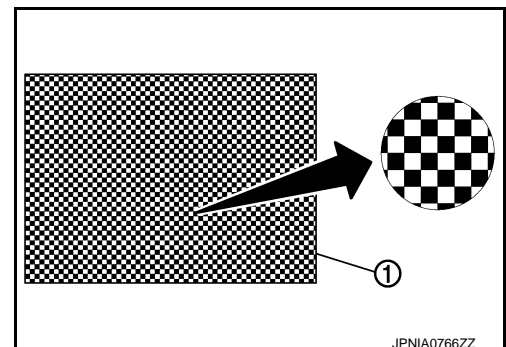

DIAGNOSIS SYSTEM (COMBINATION METER)

< SYSTEM DESCRIPTION >

- All segments of the information display (segment information display) (1) are displayed.

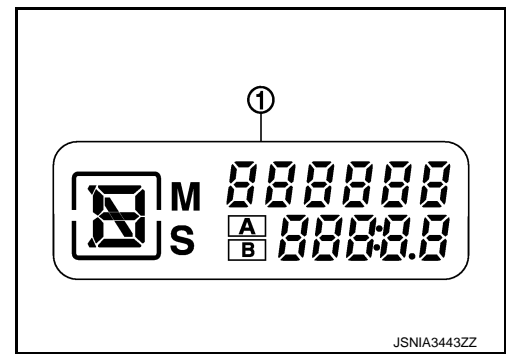

NOTE:

- Check the following items when the self-diagnosis mode of the combination meter does not start. Replace combination meter if the following items are normal.
 - Combination meter power supply and ground circuit.
 - Meter control switch signal circuit (trip reset switch signal circuit) and meter control switch.
 - If any of the dots are not displayed, replace combination meter.

7. Each meter activates by pressing the trip reset switch.

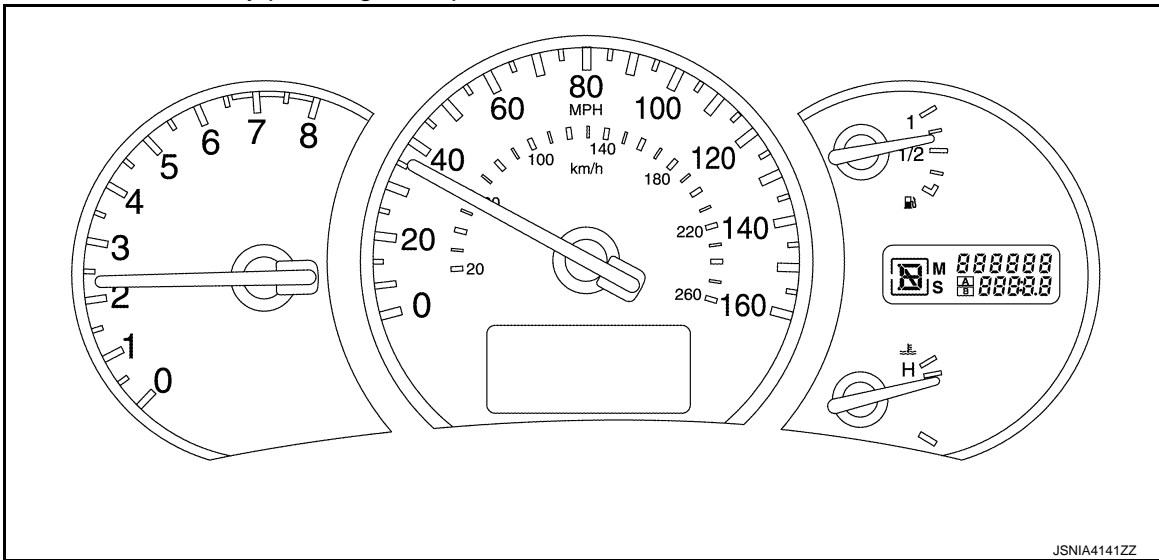

NOTE:

- If any of the meters or gauges is not activated, replace combination meter.
- The figure is reference.

CONSULT Function

INFOID:0000000011324097

CONSULT APPLICATION ITEMS

CONSULT can perform the following diagnosis modes via CAN communication and the combination meter.

System	Diagnosis mode	Description
METER/M&A	Self Diagnostic Result	The combination meter checks the conditions and displays memorized errors.
	Data Monitor	Displays the combination meter input/output data in real time.
	Warning history	Lighting history of the warning lamp and indicator lamp can be checked.

SELF DIAG RESULT

Refer to [MWI-48, "DTC Index"](#).

DATA MONITOR

NOTE:

The following table includes information (items) inapplicable to this vehicle. For information (items) applicable to this vehicle, refer to CONSULT display items.

Display Item List

DIAGNOSIS SYSTEM (COMBINATION METER)

< SYSTEM DESCRIPTION >

X: Applicable

Display item [Unit]	MAIN SIGNALS	Description
SPEED METER [km/h]	X	Value of vehicle speed signal received from ABS actuator and electric unit (control unit) via CAN communication. NOTE: 655.35 is displayed when the malfunction signal is received.
SPEED OUTPUT [km/h]	X	Vehicle speed signal value transmitted to other units via CAN communication. NOTE: 655.35 is displayed when the malfunction signal is received.
ODO OUTPUT [km/h or mph]		Odometer signal value transmitted to other units via CAN communication.
TACHO METER [rpm]	X	Value of the engine speed signal received from ECM via CAN communication. NOTE: 8191.875 is displayed when the malfunction signal is received.
FUEL METER [L]	X	Fuel level indicated on combination meter.
W TEMP METER [°C]	X	Value of engine coolant temperature signal is received from ECM via CAN communication. NOTE: 215 is displayed when the malfunction signal is input.
ABS W/L [On/Off]		Status of ABS warning lamp detected from ABS warning lamp signal is received from ABS actuator and electric unit (control unit) via CAN communication.
VDC/TCS IND [On/Off]		Status of VDC OFF indicator lamp detected from VDC OFF indicator lamp signal is received from ABS actuator and electric unit (control unit) via CAN communication.
SLIP IND [On/Off]		Status of VDC warning lamp detected from VDC warning lamp signal received from ABS actuator and electric unit (control unit) via CAN communication.
BRAKE W/L [On/Off]		Status of brake warning lamp detected from brake warning lamp signal is received from ABS actuator and electric unit (control unit) via CAN communication. NOTE: Displays "Off" if the brake warning lamp is illuminated when the valve check starts, the parking brake switch is turned ON or the brake fluid level switch is turned ON.
DOOR W/L [On/Off]		Status of door open warning detected from door switch signal received from BCM via CAN communication.
HI-BEAM IND [On/Off]		Status of high beam indicator lamp detected from high beam request signal is received from BCM via CAN communication.
TURN IND [On/Off]		Status of turn indicator lamp detected from turn indicator signal is received from BCM via CAN communication.
LIGHT IND [On/Off]		<ul style="list-style-type: none"> • Status of position lamp indicator lamp detected from dimmer signal is received from BCM via CAN communication. (For U.S.A) • Status of position lamp indicator lamp detected from position light request signal is received from BCM via CAN communication. (For Canada)
OIL W/L [On/Off]		Status of oil pressure warning lamp detected from oil pressure warning lamp signal is received from ECM via CAN communication.
MIL [On/Off]		Status of malfunction indicator lamp detected from malfunctioning indicator lamp signal is received from ECM via CAN communication.
CRUISE IND [On/Off]		Status of CRUISE indicator detected from ASCD status signal is received from ECM via CAN communication.
SET IND [Off]		This item is displayed, but cannot be monitored.
CRUISE W/L [Off]		This item is displayed, but cannot be monitored.
BA W/L [Off]		This item is displayed, but cannot be monitored.



DIAGNOSIS SYSTEM (COMBINATION METER)

< SYSTEM DESCRIPTION >

Display item [Unit]	MAIN SIGNALS	Description	
O/D OFF IND [On/Off]		Status of O/D OFF indicator detected from O/D OFF indicator signal is received from CVT shift selector.	A
4WD W/L [Off]		This item is displayed, but cannot be monitored.	B
4WD LOCK IND [Off]		This item is displayed, but cannot be monitored.	C
FUEL W/L [On/Off]		Low fuel warning status detected by the identified fuel level.	
WASHER W/L [On/Off]		Status of low washer fluid warning judged from washer level switch input to combination meter.	D
AIR PRES W/L [On/Off]		Status of low tire pressure warning lamp judged from TPMS malfunction warning lamp signal received from BCM with CAN communication line.	E
KEY G/Y W/L [On/Off]		Status of Intelligent Key system malfunction detected from Intelligent Key warning display signal is received from BCM via CAN communication.	
EPS W/L [On/Off]		Status of EPS warning lamp judged from EPS warning lamp signal received from EPS control unit with CAN communication line.	F
AFS OFF IND [Off]		This item is displayed, but cannot be monitored.	G
ECO MODE IND [Off]		This item is displayed, but cannot be monitored.	
LCD [B&P N, B&P I, ID NG, ROTAT, SFT P, INSRT, BATT, NO KY, OUTKY, LK WN, KY>PSW, Off]		Displays status of Intelligent Key system warning judged from meter display signal received from BCM with CAN communication line.	H
ACC TARGET [Off]		This item is displayed, but cannot be monitored.	I
ACC DISTANCE [Off]		This item is displayed, but cannot be monitored.	J
ACC OWN VHL [Off]		This item is displayed, but cannot be monitored.	
ACC SET SPEED [Off]		This item is displayed, but cannot be monitored.	K
ACC UNIT [Off]		This item is displayed, but cannot be monitored.	L
SHIFT IND [P, R, N, D, L]		Status of shift position indicator judged from shift position signal received from TCM with CAN communication line.	
BSW IND [Off]		This item is displayed, but cannot be monitored.	M
BSW W/L [On/Off]		Status of BSW warning lamp judged from BSW warning lamp signal received from camera control unit via CAN communication.	MWI
FUEL CAP W/L [On/Off]		Status of fuel filler cap warning detected from fuel filler cap warning display signal is received from ECM via CAN communication.	
O/D OFF SW [On/Off]		Status of overdrive control switch.	O
M RANGE SW [Off]		This item is displayed, but cannot be monitored.	
NM RANGE SW [Off]		This item is displayed, but cannot be monitored.	P
AT SFT UP SW [Off]		This item is displayed, but cannot be monitored.	
AT SFT DWN SW [Off]		This item is displayed, but cannot be monitored.	

DIAGNOSIS SYSTEM (COMBINATION METER)

< SYSTEM DESCRIPTION >

Display item [Unit]	MAIN SIGNALS	Description
COMP F/B SIG [On/Off]		A/C compressor activation condition that ECM judges according to the water temperature and the acceleration degree.
PKB SW [On/Off]		Status of parking brake switch.
BUCKLE SW [On/Off]		Status of seat belt buckle switch (driver side).
BRAKE OIL SW [On/Off]		Status of brake fluid level switch.
A/C AMP CONN [On/Off]		Status of A/C auto amp. connection recognition signal.
ENTER SW [On/Off]		Status of  (ENTER) switch.
SELECT SW [On/Off]		Status of  (SELECT) switch.
ECO MODE SW [Off]		This item is displayed, but cannot be monitored.
DISTANCE [km]		Value of distance to empty calculated by combination meter.
OUTSIDE TEMP [°C or °F]		Ambient temperature value converted from ambient sensor signal received from ambient sensor. NOTE: This may not match with the temperature value indicated on the information display. (Because the information display value is a corrected value from the ambient sensor input value.)
FUEL LOW SIG [On/Off]		Status of fuel level low warning signal to output to AV control unit via CAN communication.
BUZZER [On/Off]	X	Buzzer status (in the combination meter) is detected from the buzzer output signal received from each unit via CAN communication and the warning output condition of the combination meter.
TPMS PRESS L [On/Off]		Status of low tire pressure warning judged from low tire pressure warning lamp signal received from BCM with CAN communication line.
4WD AUTO IND [Off]		This item is displayed, but cannot be monitored.

NOTE:

Some items are not available according to vehicle specification.

Warning History

- Stores histories when warning/indicator lamp is turned on.
- “Warning History” indicates the “TIME” when the warning/indicator lamp is turned on.
- The “TIME” above is:
 - 0: The condition that the warning/indicator lamp has been turned on 1 or more times after starting the engine and waiting for 30 seconds.
 - 1 - 39: The number of times the engine was restarted after the 0 condition.
 - NO Warning History: Stores NO (0) turning on history of warning/indicator lamp.

NOTE:

- Warning History is not stored for approximately 30 seconds after the engine starts.
- Brake warning lamp does not store any history when the parking brake is applied or the brake fluid level gets low.

Display Item

Display item	Description
ABS W/L	Lighting history of ABS warning lamp.
VDC/TCS IND	Lighting history of VDC OFF indicator lamp.
SLIP IND	Lighting history of VDC warning lamp.

DIAGNOSIS SYSTEM (COMBINATION METER)

< SYSTEM DESCRIPTION >

Display item	Description	
BRAKE W/L	Lighting history of brake warning lamp.	A
DOOR W/L	Lighting history of door open warning.	
OIL W/L	Lighting history of oil pressure warning lamp.	B
C-ENG W/L	Lighting history of malfunction indicator lamp.	
CRUISE IND	Lighting history of CRUISE indicator.	
O/D OFF IND	Lighting history of O/D OFF indicator lamp.	C
FUEL W/L	Lighting history of low fuel level warning.	
WASHER W/L	Lighting history of low washer fluid warning.	D
AIR PRES W/L	Lighting history of low tire pressure warning lamp.	
KEY G/Y W/L	Lighting history of Intelligent Key system malfunction.	
EPS W/L	Lighting history of EPS warning lamp.	E
BSW W/L	Lighting history of BSW warning lamp.	

NOTE:

In items displayed on the CONSULT screen, only those listed in the above table are used.

F

G

H

I

J

K

L

M

MWI

O

P

COMBINATION METER

< ECU DIAGNOSIS INFORMATION >

ECU DIAGNOSIS INFORMATION

COMBINATION METER

Reference Value

INFOID:0000000011324098

VALUES ON THE DIAGNOSIS TOOL

NOTE:

The following table includes information (items) inapplicable to this vehicle. For information (items) applicable to this vehicle, refer to CONSULT display items.

Monitor Item	Condition		Value/Status
SPEED METER [km/h]	Ignition switch ON	While driving	Input value of vehicle speed signal (CAN communication signal) NOTE: 655.35 is displayed when the malfunction signal is received
SPEED OUTPUT [km/h]	Ignition switch ON	While driving	Output value of vehicle speed signal (CAN communication signal) NOTE: 655.35 is displayed when the malfunction signal is received
ODO OUTPUT [km/h or mph]	Ignition switch ON	—	Output value of odometer signal (CAN communication signal)
TACHO METER [rpm]	Ignition switch ON	Engine running	Input value of engine speed signal (CAN communication signal) NOTE: 8191.875 is displayed when the malfunction signal is received
FUEL METER [L]	Ignition switch ON	—	Input value of fuel level sensor signal
W TEMP METER [°C]	Ignition switch ON	—	Input value of engine coolant temperature signal (CAN communication signal) NOTE: 215 is displayed when the malfunction signal is input
ABS W/L	Ignition switch ON	ABS warning lamp ON	On
		ABS warning lamp OFF	Off
VDC/TCS IND	Ignition switch ON	VDC OFF indicator lamp ON	On
		VDC OFF indicator lamp OFF	Off
SLIP IND	Ignition switch ON	VDC warning lamp ON	On
		VDC warning lamp OFF	Off
BRAKE W/L	Ignition switch ON	Brake warning lamp ON	On
		Brake warning lamp OFF	Off
DOOR W/L	Ignition switch ON	Door open warning ON	On
		Door open warning OFF	Off
HI-BEAM IND	Ignition switch ON	High-beam indicator lamp ON	On
		High-beam indicator lamp OFF	Off
TURN IND	Ignition switch ON	Turn signal indicator lamp ON	On
		Turn signal indicator lamp OFF	Off
LIGHT IND	Ignition switch ON	Position lamp indicator lamp ON	On
		Position lamp indicator lamp OFF	Off

COMBINATION METER

< ECU DIAGNOSIS INFORMATION >

Monitor Item	Condition		Value/Status	
OIL W/L	Ignition switch ON	Oil pressure warning lamp ON	On	A
		Oil pressure warning lamp OFF	Off	
MIL	Ignition switch ON	Malfunction indicator lamp ON	On	B
		Malfunction indicator lamp OFF	Off	
CRUISE IND	Ignition switch ON	CRUISE indicator ON	On	C
		CRUISE indicator OFF	Off	
SET IND	Ignition switch ON	NOTE: This item is displayed, but cannot be monitored.	Off	D
CRUISE W/L	Ignition switch ON	NOTE: This item is displayed, but cannot be monitored.	Off	E
BA W/L	Ignition switch ON	NOTE: This item is displayed, but cannot be monitored.	Off	F
O/D OFF IND	Ignition switch ON	O/D OFF indicator lamp ON	On	
		O/D OFF indicator lamp OFF	Off	
4WD W/L	Ignition switch ON	NOTE: This item is displayed, but cannot be monitored.	Off	G
4WD LOCK IND	Ignition switch ON	NOTE: This item is displayed, but cannot be monitored.	Off	H
FUEL W/L	Ignition switch ON	During low fuel warning indication	On	I
		Other than the above	Off	
WASHER W/L	Ignition switch ON	During low washer fluid warning indication	On	J
		Other than the above	Off	
AIR PRES W/L	Ignition switch ON	Low tire pressure warning lamp ON	On	
		Low tire pressure warning lamp OFF	Off	K
KEY G/Y W/L	Ignition switch ON	During Intelligent Key system malfunction indication	On	
		Other than the above	Off	L
EPS W/L	Ignition switch ON	EPS warning lamp ON	On	
		EPS warning lamp OFF	Off	M
AFS OFF IND	Ignition switch ON	NOTE: This item is displayed, but cannot be monitored.	Off	
ECO MODE IND	Ignition switch ON	NOTE: This item is displayed, but cannot be monitored.	Off	MWI



COMBINATION METER

< ECU DIAGNOSIS INFORMATION >

Monitor Item	Condition		Value/Status
LCD	Ignition switch ON	During engine start information indication	B&P I
	Ignition switch ACC	During engine start information indication	B&P N
	Ignition switch LOCK	During key ID warning indication	ID NG
	Ignition switch LOCK	During steering lock information indication	ROTAT
	Ignition switch LOCK	During P position warning indication	SFT P
	Ignition switch LOCK	During Intelligent Key insert information indication	INSRT
	Ignition switch LOCK	During Intelligent Key low battery warning indication	BATT
	Ignition switch ON	During take away warning indication	NO KY
	Ignition switch LOCK	During key warning indication	OUTKY
	Ignition switch ON	During ACC warning indication	LK WN
	Ignition switch LOCK	During Key ID verification information indication	KY>PSW
	Ignition switch ON	Other than above	Off
ACC TARGET	Ignition switch ON	NOTE: This item is displayed, but cannot be monitored.	Off
ACC DISTANCE	Ignition switch ON	NOTE: This item is displayed, but cannot be monitored.	Off
ACC OWN VHL	Ignition switch ON	NOTE: This item is displayed, but cannot be monitored.	Off
ACC SET SPEED	Ignition switch ON	NOTE: This item is displayed, but cannot be monitored.	Off
ACC UNIT	Ignition switch ON	NOTE: This item is displayed, but cannot be monitored.	Off
SHIFT IND	Ignition switch ON	During the indication of "P" by shift position indicator	P
		During the indication of "R" by shift position indicator	R
		During the indication of "N" by shift position indicator	N
		During the indication of "D" by shift position indicator	D
		During the indication of "L" by shift position indicator	L
BSW IND	Ignition switch ON	NOTE: This item is displayed, but cannot be monitored.	Off
BSW W/L	Ignition switch ON	BSW warning lamp ON	On
		BSW warning lamp OFF	Off

COMBINATION METER

< ECU DIAGNOSIS INFORMATION >

Monitor Item	Condition		Value/Status	
FUEL CAP W/L	Ignition switch ON	During fuel filler cap warning display indication	On	A
		Other than above	Off	B
O/D OFF SW	Ignition switch ON	Overdrive control switch ON	On	
		Overdrive control switch OFF	Off	
M RANGE SW	Ignition switch ON	NOTE: This item is displayed, but cannot be monitored.	Off	C
NM RANGE SW	Ignition switch ON	NOTE: This item is displayed, but cannot be monitored.	Off	D
AT SFT UP SW	Ignition switch ON	NOTE: This item is displayed, but cannot be monitored.	Off	E
AT SFT DWN SW	Ignition switch ON	NOTE: This item is displayed, but cannot be monitored.	Off	F
COMP F/B SIG	Ignition switch ON	A/C compressor activation condition	On	
		A/C compressor deactivation condition	Off	G
PKB SW	Ignition switch ON	Parking brake switch ON	On	
		Parking brake switch OFF	Off	H
BUCKLE SW	Ignition switch ON	Driver seat belt not fastened	On	
		Driver seat belt fastened	Off	I
BRAKE OIL SW	Ignition switch ON	Brake fluid level switch ON	On	
		Brake fluid level switch OFF	Off	J
A/C AMP CONN	Ignition switch ON	Other than the following	On	
		Receives ambient sensor power signal	Off	
ENTER SW	Ignition switch ON	When  switch (enter switch) is pressed	On	K
		Other than above	Off	
SELECT SW	Ignition switch ON	When  switch (select switch) is pressed	On	L
		Other than above	Off	
ECO MODE SW	Ignition switch ON	NOTE: This item is displayed, but cannot be monitored.	Off	M
DISTANCE [km]	Ignition switch ON	—	Distance to empty calculated by combination meter	MWI
OUTSIDE TEMP [°C or °F]	Ignition switch ON	—	Input value of ambient sensor signal (CAN communication signal) NOTE: This may not match the indicated value on the information display.	O
FUEL LOW SIG	Ignition switch ON	During low fuel warning indication	On	
		Other than above	Off	P
BUZZER	Ignition switch ON	Buzzer ON	On	
		Buzzer OFF	Off	

COMBINATION METER

< ECU DIAGNOSIS INFORMATION >

Monitor Item	Condition		Value/Status
TPMS PRESS L	Ignition switch ON	During low tire pressure warning indication	On
		Other than above	Off
4WD AUTO IND	Ignition switch ON	NOTE: This item is displayed, but cannot be monitored.	Off

NOTE:

Some items are not available according to vehicle specification.

TERMINAL LAYOUT

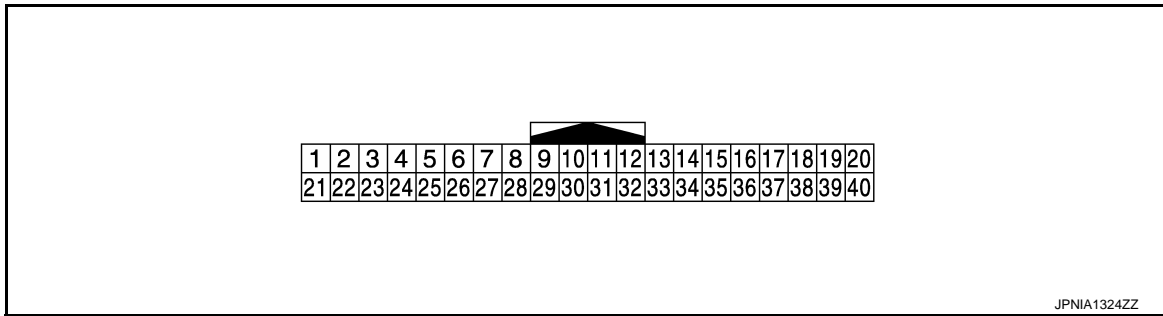





PHYSICAL VALUES

Terminal No. (Wire color)		Description		Condition		Value (Approx.)
+	-	Signal name	Input/ Output			
1 (O) ^{*1} (P) ^{*2}	Ground	Battery power supply	Input	Ignition switch OFF	—	Battery voltage
2 (Y) ^{*1} (G) ^{*2}	Ground	Ignition signal	Input	Ignition switch ON	—	Battery voltage
3 (B)	Ground	Ground	—	Ignition switch ON	—	0 V
4 (B)	Ground	Ground	—	Ignition switch ON	—	0 V

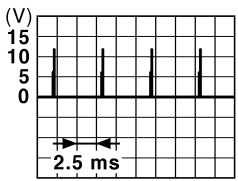
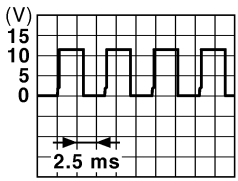
COMBINATION METER

< ECU DIAGNOSIS INFORMATION >

Terminal No. (Wire color)		Description		Condition	Value (Approx.)	
+	-	Signal name	Input/ Output			
5 (B/P) ^{*1} (B) ^{*2}	Ground	Illumination control signal	Output	Ignition switch ON	<ul style="list-style-type: none"> Lighting switch 1ST position When meter illumination is maximum 	
				Ignition switch ON	<ul style="list-style-type: none"> Lighting switch 1ST position When meter illumination is step 11 	
				Ignition switch ON	<ul style="list-style-type: none"> Lighting switch 1ST position When meter illumination is minimum 	12 V
8 (SB) ^{*1} (G) ^{*2}	10 (P)	Trip reset switch signal	Input	Ignition switch ON	When trip reset switch is pressed	0 V
				Other than the above	5 V	
10 (P)	Ground	Meter control switch ground	—	Ignition switch ON	—	0 V
11 (G)	10 (P)	Enter switch signal	Input	Ignition switch ON	When  switch (enter switch) is pressed	0 V
				Other than the above	5 V	
12 (BR) ^{*1} (R) ^{*2}	10 (P)	Select switch signal	Input	Ignition switch ON	When  switch (select switch) is pressed	0 V
				Other than the above	5 V	
13 (Y) ^{*1} (W) ^{*2}	10 (P)	Illumination control switch signal (+)	Input	Ignition switch ON	When  switch [illumination control switch (+)] is pressed	0 V
				Other than the above	5 V	
14 (V) ^{*1} (G) ^{*2}	10 (P)	Illumination control switch signal (-)	Input	Ignition switch ON	When  switch [illumination control switch (-)] is pressed	0 V
				Other than the above	5 V	
15 (BR)	—	Air bag signal	Input	—	—	—

A
B
C
D
E
F
G
H
I
J
K
L
M
MWI
O
P

COMBINATION METER

< ECU DIAGNOSIS INFORMATION >

Terminal No. (Wire color)		Description		Condition	Value (Approx.)	
+	-	Signal name	Input/ Output			
16 (L)	Ground	Engine coolant temperature signal	Output	Ignition switch ON	<p style="text-align: right; font-size: small;">JSNIA3528ZZ</p>	
				At idle [after warming up, approx. 80°C (176°F)]	<p style="text-align: right; font-size: small;">JSNIA3530ZZ</p>	
18 (LG) ^{*1} (L) ^{*2}	Ground	Ambient sensor signal	Input	Ignition switch ON	<p style="text-align: right; font-size: small;">JSNIA0014GB</p>	
19 (R)	Ground	A/C auto amp. connection recognition signal	Input	Ignition switch ON	5 V	
20 (Y) ^{*1} (G) ^{*2}	Ground	Ambient sensor ground	—	Ignition switch ON	0 V	
21 (L)	—	CAN-H	—	—	—	
22 (P)	—	CAN-L	—	—	—	
23 (B)	Ground	Ground	—	Ignition switch ON	0 V	
24 (B)	Ground	Fuel level sensor ground	—	Ignition switch ON	0 V	
25 (BR) ^{*1} (W) ^{*2}	Ground	Alternator signal	Input	Ignition switch ON	Charge warning lamp ON	12 V
				Charge warning lamp OFF	0 V	
26 (BR)	Ground	Parking brake switch signal	Input	Ignition switch ON	Parking brake applied.	0 V
					Parking brake released.	12 V
27 (Y) ^{*1} (BE) ^{*2}	Ground	Brake fluid level switch signal	Input	Ignition switch ON	Brake fluid level is normal	12 V
					Brake fluid level is less than LOW level	0 V
28 (V)	Ground	Security signal	Input	Ignition switch ON	Security indicator lamp ON	0 V
					Security indicator lamp OFF	12 V

COMBINATION METER

< ECU DIAGNOSIS INFORMATION >

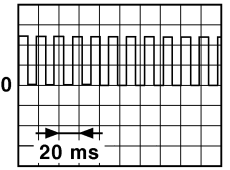
Terminal No. (Wire color)		Description		Condition		Value (Approx.)
+	-	Signal name	Input/ Output			
29 (G)	Ground	Washer level switch signal	Input	Ignition switch ON	Washer level switch ON	0 V
				Ignition switch ON	Washer level switch OFF	5 V
31 (SB)	Ground	Vehicle speed signal (8-pulse)	Output	Ignition switch ON	Speedometer operated [When vehicle speed is approx. 40 km/h (25 MPH)]	<p>NOTE: The maximum voltage varies depending on the specification (destination unit).</p>  <p style="text-align: right; font-size: small;">JSNIA0012GB</p>
32 (P)	Ground	Overdrive control switch signal	Input	Ignition switch ON	When overdrive control switch is pressed	0 V
				Ignition switch ON	Other than the above	5 V
34 (O)	24 (B)	Fuel level sensor signal	Input	Ignition switch ON	—	MWI-77. "Component Inspection"
35 (P) ^{*1} (BR) ^{*2}	Ground	Seat belt buckle switch signal (driver side)	Input	Ignition switch ON	When driver seat belt is fastened	5 V
				Ignition switch ON	When driver seat belt is unfastened	0 V
36 (BR)	—	Passenger seat belt warning signal	Input	—	—	—

*1: With automatic drive positioner

*2: Without automatic drive positioner

Fail-Safe

INFOID:000000011324099

FAIL-SAFE

The combination meter activates the fail-safe control if CAN communication with each unit is malfunctioning.

Function	Specifications
Speedometer	Reset to zero by suspending communication.
Tachometer	
Engine coolant temperature gauge	
Illumination control	When suspending communication, changes to nighttime mode.

MWI

COMBINATION METER

< ECU DIAGNOSIS INFORMATION >

Function		Specifications	
Information display	Odo/trip meter	An indicated value is maintained at communications blackout.	
	Shift position indicator	The display turns OFF by suspending communication.	
	Interrupt indication	Door open warning	The display turns OFF by suspending communication.
		Fuel filler cap warning	
		Low tire pressure warning	
	Trip computer	Current fuel consumption	<ul style="list-style-type: none"> When reception time of an abnormal signal is 2 seconds or less, the last received datum is used for calculation to indicate the result. When reception time of an abnormal signal is more than two seconds, the last calculation results are indicated.
		Average fuel consumption	
		Distance to empty	
Average vehicle speed			
Travel distance			
Buzzer		The buzzer turns OFF by suspending communication.	
Warning lamp/indicator lamp	ABS warning lamp	The lamp turns ON by suspending communication.	
	VDC warning lamp		
	Brake warning lamp		
	EPS warning lamp		
	Malfunction indicator lamp		
	Low tire pressure warning lamp	The lamp blinking caused by suspending communication.	
	High beam indicator lamp	The lamp turns OFF by suspending communication.	
	Turn signal indicator lamp		
	VDC OFF indicator lamp		
	O/D OFF indicator lamp		
	Position lamp indicator lamp		
	CRUISE indicator lamp		
	Oil pressure warning lamp		
	BSW warning lamp		
Key warning lamp			

DTC Index

INFOID:000000011324100

Display contents of CONSULT	Diagnostic item is detected when...	Refer to
CAN COMM CIRCUIT [U1000]	When combination meter is not transmitting or receiving CAN communication signal for 2 seconds or more.	MWI-66. "Diagnosis Procedure"
CONTROL UNIT (CAN) [U1010]	When detecting error during the initial diagnosis of the CAN controller of combination meter.	MWI-67. "Diagnosis Procedure"
VEHICLE SPEED [B2205]	The abnormal vehicle speed signal is input from the ABS actuator and electric unit (control unit) for 2 seconds or more.	MWI-68. "Diagnosis Procedure"
ENGINE SPEED [B2267]	If ECM continuously transmits abnormal engine speed signals for 2 seconds or more.	MWI-69. "Diagnosis Procedure"
WATER TEMP [B2268]	If ECM continuously transmits abnormal engine coolant temperature signals for 60 seconds or more.	MWI-70. "Diagnosis Procedure"

IPDM E/R

< ECU DIAGNOSIS INFORMATION >

IPDM E/R

List of ECU Reference

INFOID:0000000011324101

ECU	Reference
IPDM E/R	PCS-16. "Reference Value"
	PCS-23. "Fail-safe"
	PCS-24. "DTC Index"

A
B
C
D
E
F
G
H
I
J
K
L
M
O
P

MWI

METER SYSTEM

< WIRING DIAGRAM >

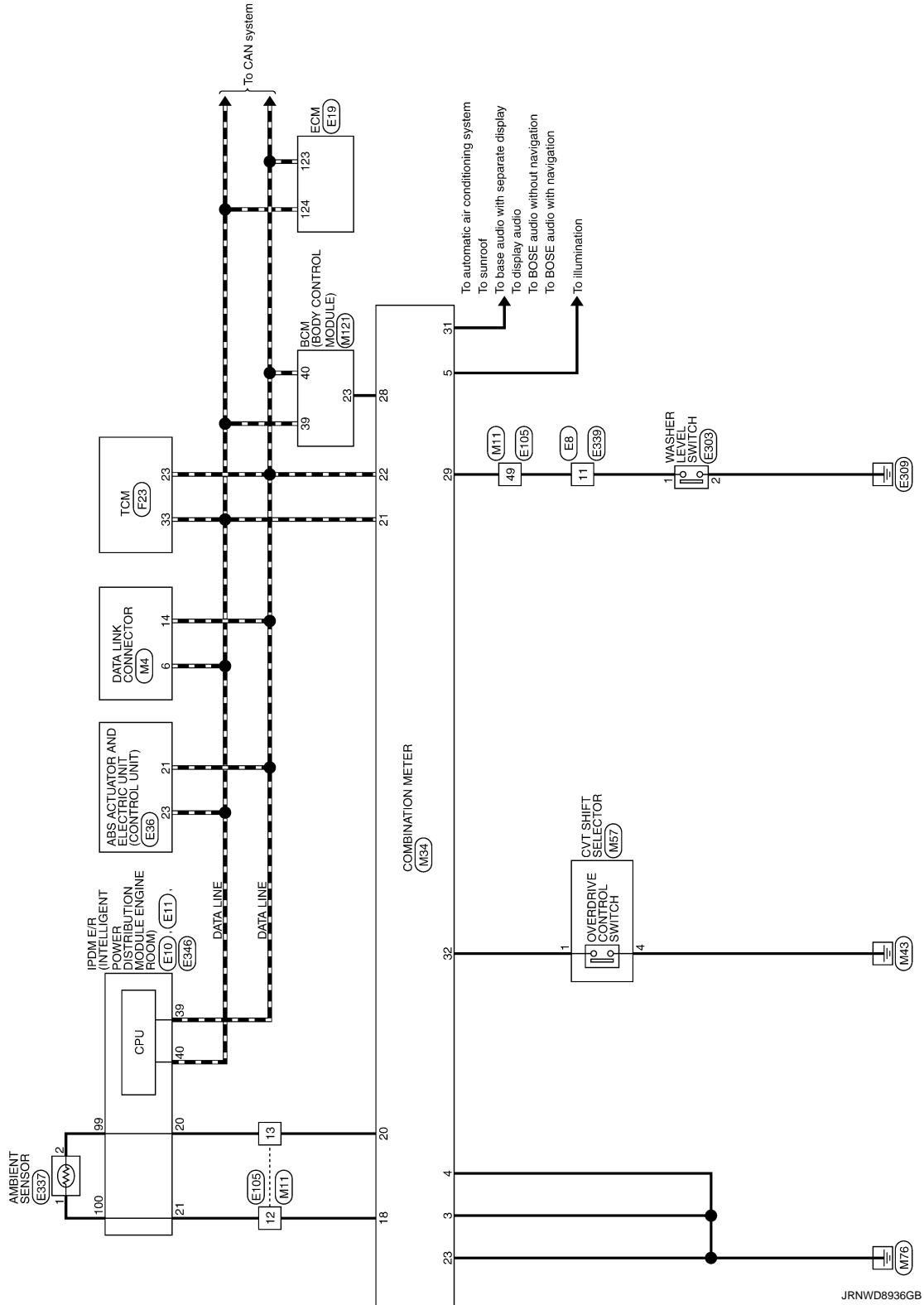

A
B
C
D
E
F
G
H
I
J
K
L
M
N
O
P

MWI

METER SYSTEM

< WIRING DIAGRAM >

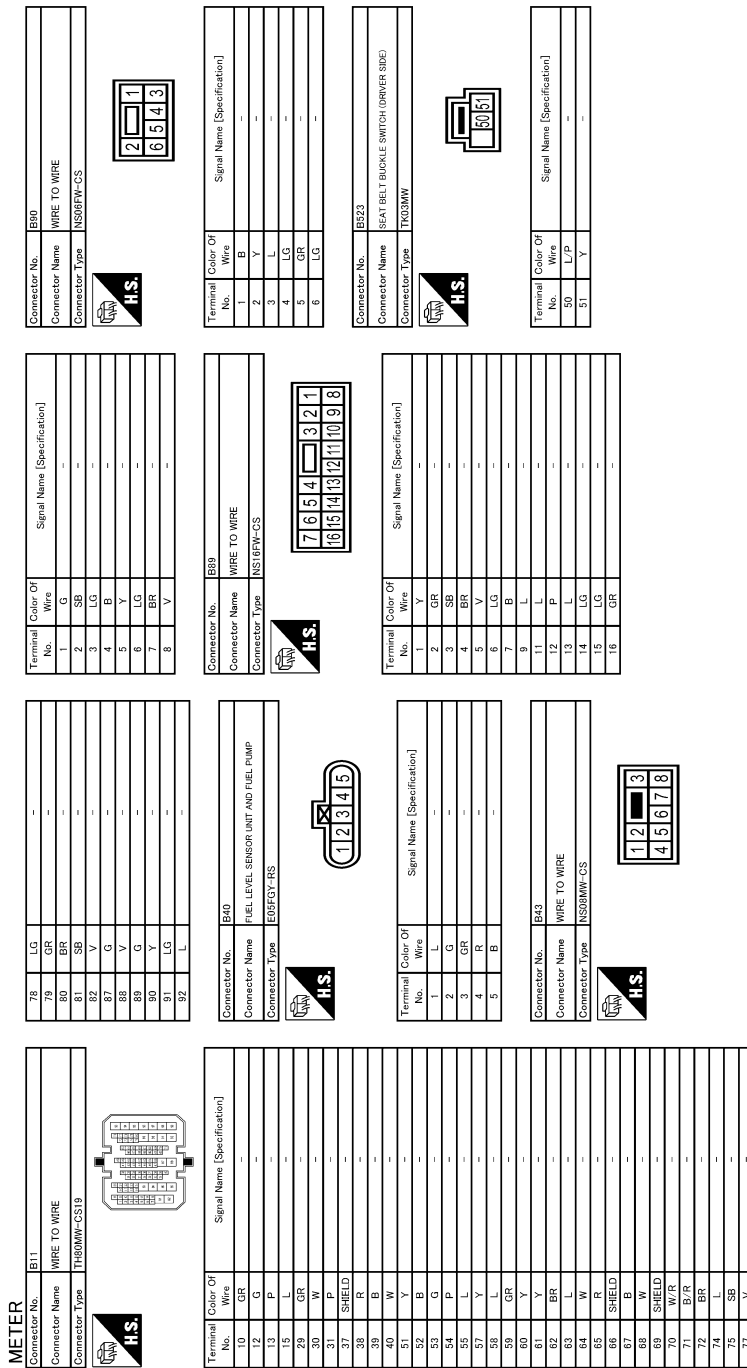

JRNWD8937GB

METER SYSTEM

< WIRING DIAGRAM >

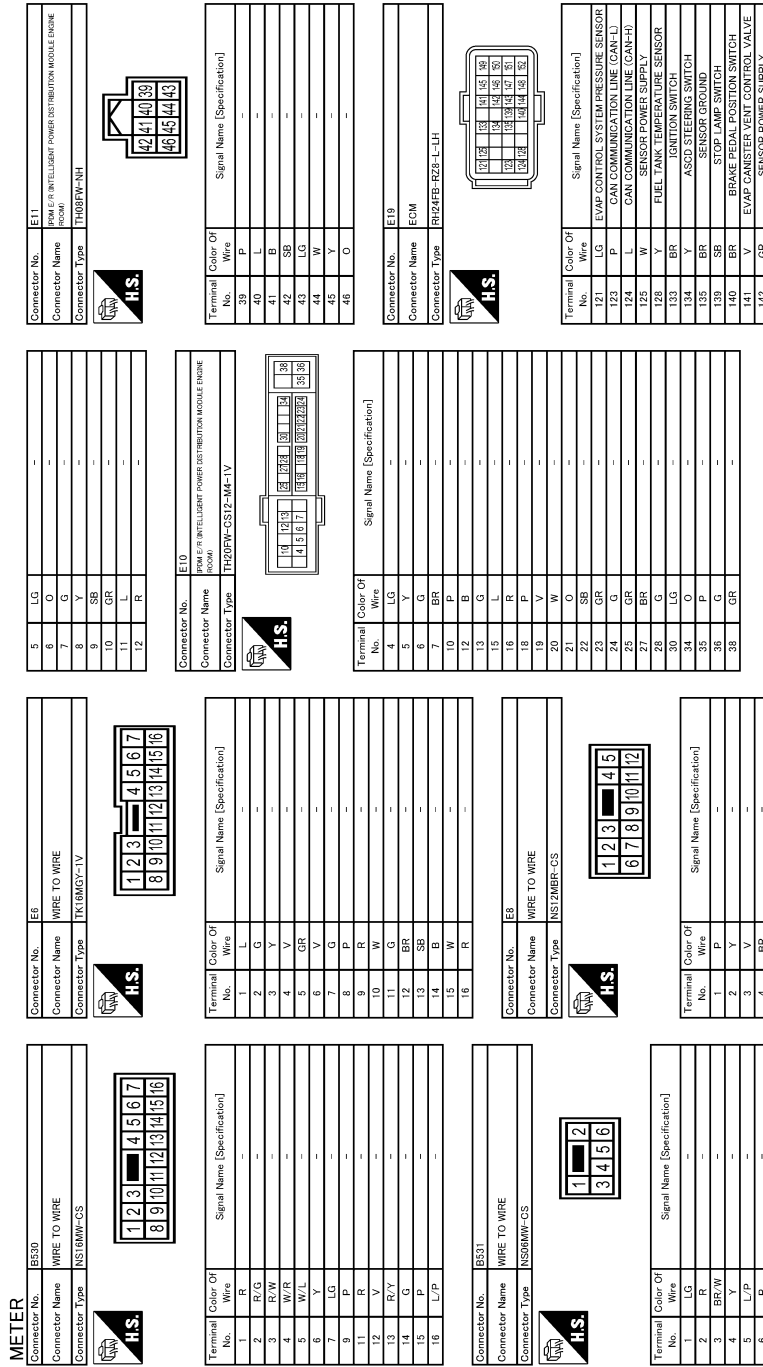

A
B
C
D
E
F
G
H
I
J
K
L
M
MWI
O
P

METER SYSTEM

< WIRING DIAGRAM >

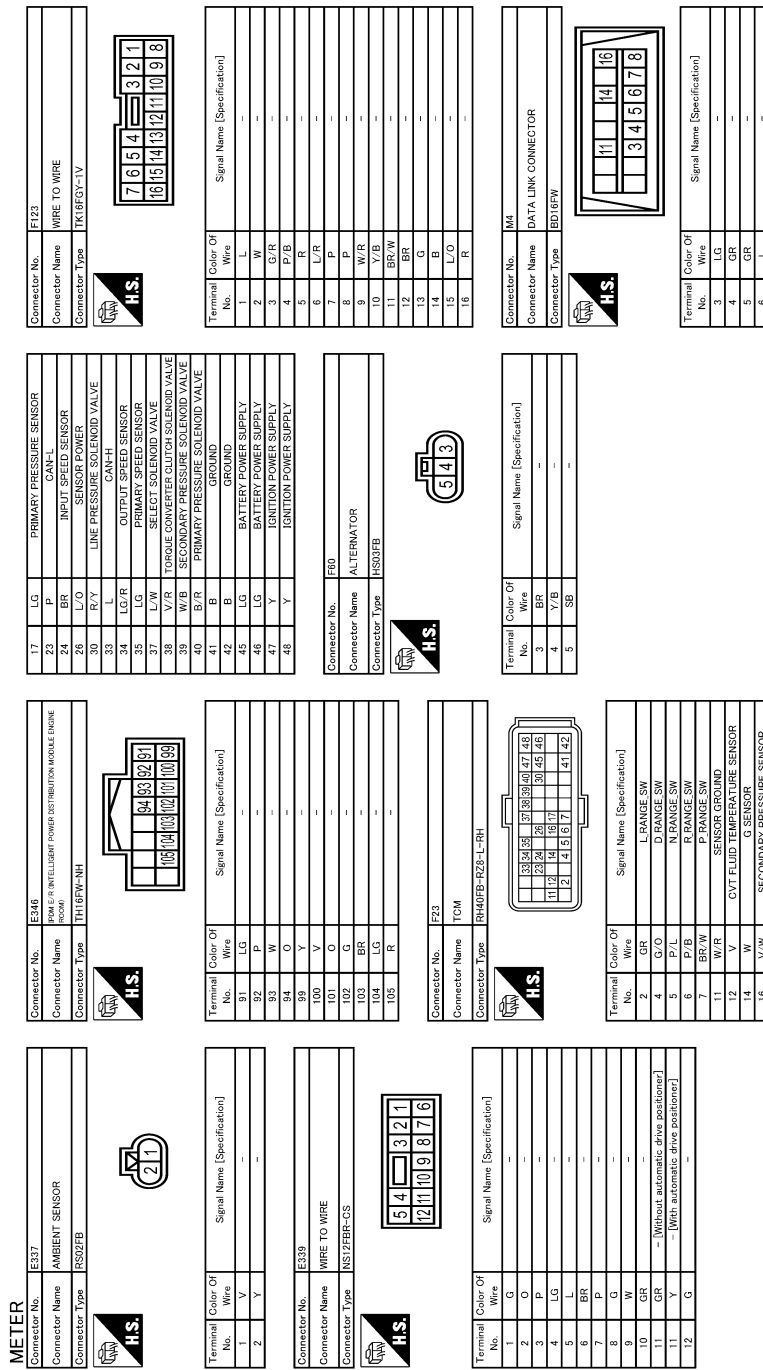

A
B
C
D
E
F
G
H
I
J
K
L
M
MWI
O
P

METER SYSTEM

< WIRING DIAGRAM >

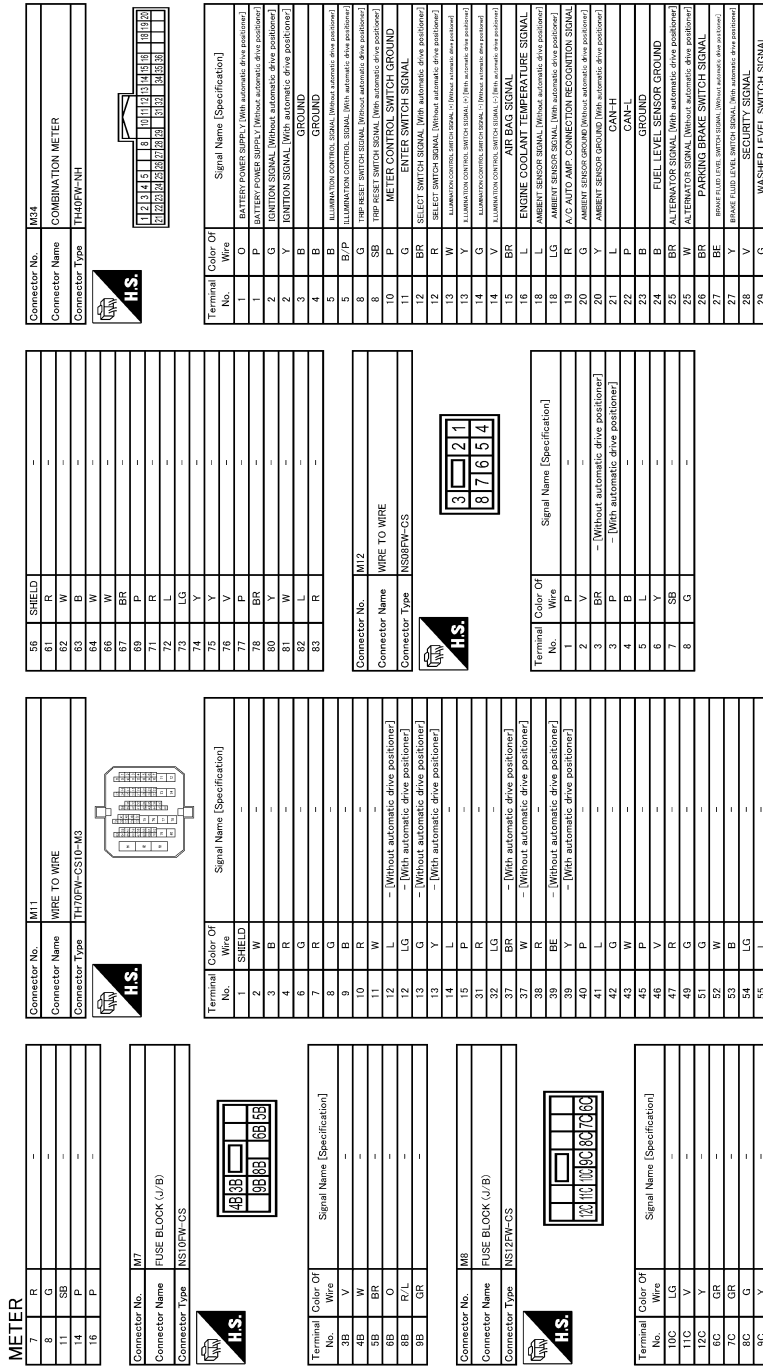

JRNWD8941GB

METER SYSTEM

< WIRING DIAGRAM >

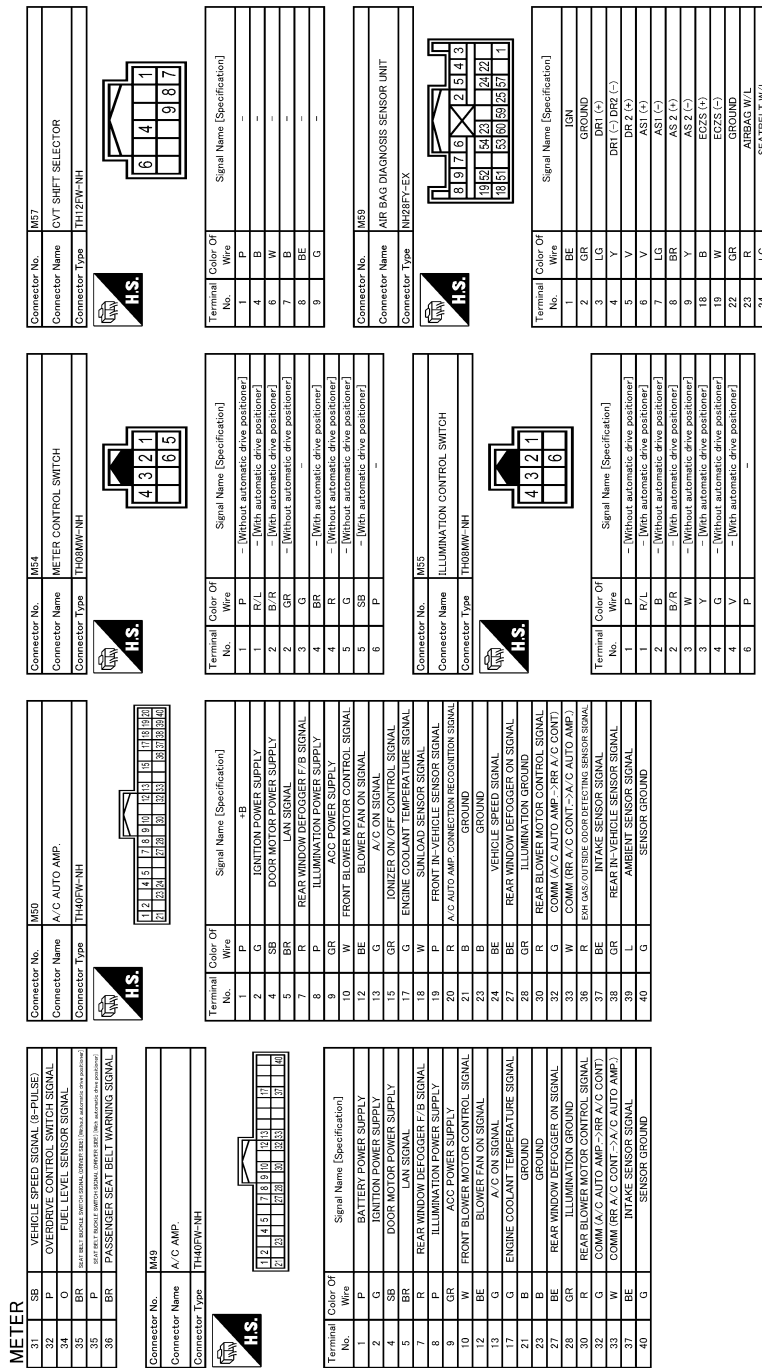

A
B
C
D
E
F
G
H
I
J
K
L
M
O
P



METER SYSTEM

< WIRING DIAGRAM >

METER

53	LG	OUTSIDE TELETYPE
54	B	SIDE SENS RH2*
52	B	SIDE SENS RH2*
53	W	SIDE SENS LH2*
54	B	SIDE SENS LH2*
57	W	DEPLOYMENT INFORMATION OUTPUT
59	L	CAN-H
60	P	CAN-L

Connector No.	IM77
Connector Name	WIRE TO WIRE
Connector Type	TH80PW-CS19

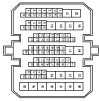

Terminal No.	Color Of Wire	Signal Name [Specification]
10	P	-
12	BE	-
13	W	-
15	R	-
29	W	-
31	BE	-
37	SIELD	-
38	B	- [Without around view monitor]
39	W	- [With around view monitor]
39	B	- [With around view monitor]
39	W	- [Without around view monitor]
40	R	-
51	LG	-
52	B	-
53	BE	-
54	P	-
55	L	-
56	Y	-
58	Y	-
59	BE	-
60	G	-
61	LG	-
62	SB	-
63	BE	-
64	R	-

65	G	-
67	SIELD	-
68	B	-
68	W	-
69	SIELD	-
70	B	-
71	W	-
72	G	-
74	GR	-
75	G	-
77	W	-
78	R	-
79	W	-
80	G	-
81	W	-
82	W	-
83	V	-
88	LG	-
89	GR	-
90	R	- [With automatic drive positioner]
90	Y	- [Without automatic drive positioner]
91	LG	-
92	BR	-

Connector No.	MI21
Connector Name	BCM (BODY CONTROL MODULE)
Connector Type	TH40FB-NH



Terminal No.	Color Of Wire	Signal Name [Specification]
1	W	REAR WINDOW DEF RELAY CONT
2	R	COMBI SW INPUT 5
3	L	COMBI SW INPUT 4
4	GE	COMBI SW INPUT 3
5	G	COMBI SW INPUT 2
6	W	COMBI SW INPUT 1
7	W	KEY CYL UNLOCK SW
8	GR	PW SW COMMON [With auto A/C]
8	Y	KEY CYL LOCK SW [With manual A/C]
9	GR	STOP LAMP SW 1
12	GR	DOOR LK & UNLK SW LOCK

13	BR	DOOR LK & UNLK SW UNLOCK
14	W	OPTICAL SENS
15	W	REAR WINDOW DEF SW
16	Y	DIMMER
17	O	SENS PWR SPALY
18	R	RECEIV/SENS CHD
21	GR	NATS ANT AMP
23	W	SECURITY IND CONT
24	B	DONGLE LINK
25	P	NATS ANT AMP
27	O	A/C ON
28	BR	BLOWER FAN ON
29	P	HAZARD SW
30	L	FR DOOR OPN SW
31	G	FR DOOR CLS SW
32	B	COMBI SW OUTPUT 6
33	W	COMBI SW OUTPUT 4
34	P	COMBI SW OUTPUT 3
35	GR	COMBI SW OUTPUT 2
36	R	COMBI SW OUTPUT 1
37	G	DETECT SW
38	BE	RECEIVER COMM
39	L	CAN-H
40	P	CAN-L

DIAGNOSIS AND REPAIR WORKFLOW (METER SYSTEM)

< BASIC INSPECTION >

BASIC INSPECTION

DIAGNOSIS AND REPAIR WORKFLOW (METER SYSTEM)

Work flow

INFOID:000000011324104

OVERALL SEQUENCE

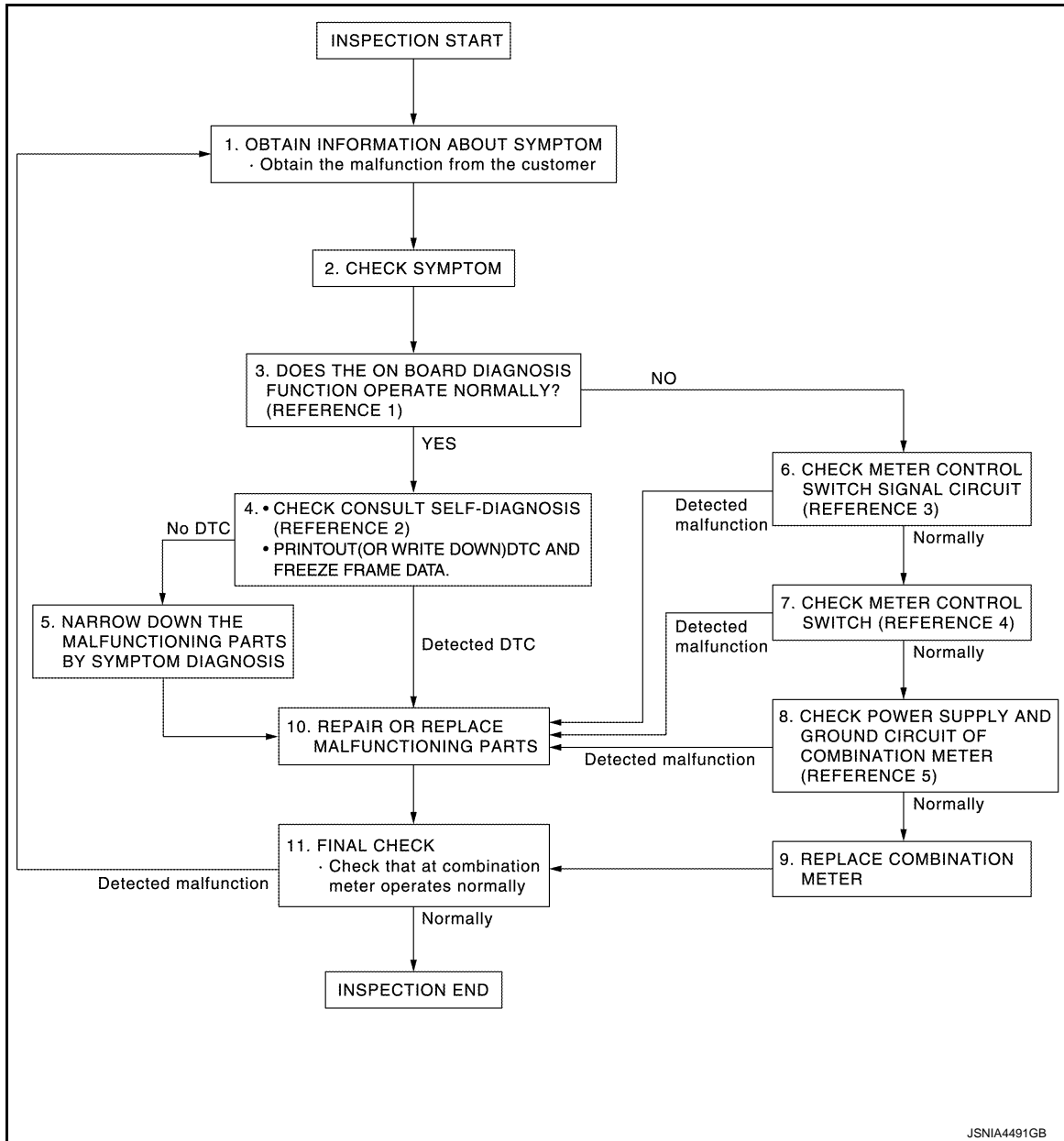

- Reference 1...[MWI-34, "On Board Diagnosis Function"](#).
- Reference 2...[MWI-48, "DTC Index"](#).
- Reference 3...[MWI-72, "Diagnosis Procedure"](#).
- Reference 4...[MWI-72, "Component Inspection"](#).
- Reference 5...[MWI-71, "COMBINATION METER : Diagnosis Procedure"](#).

DETAILED FLOW

1. OBTAIN INFORMATION ABOUT SYMPTOM

Interview the customer to obtain as much information as possible about the conditions and environment under which the malfunction occurred.

>> GO TO 2.

DIAGNOSIS AND REPAIR WORKFLOW (METER SYSTEM)

< BASIC INSPECTION >

2. CHECK SYMPTOM

- Check the symptom based on the information obtained from the customer.
- Check that any other malfunctions are present.

>> GO TO 3.

3. CHECK ON BOARD DIAGNOSIS OPERATION

Check that the on board diagnosis function operates. Refer to [MWI-34, "On Board Diagnosis Function"](#).

Does the on board diagnosis function operate normally?

YES >> GO TO 4.

NO >> GO TO 6.

4. CHECK CONSULT SELF-DIAGNOSIS RESULTS

1. Connect CONSULT and perform self-diagnosis. Refer to [MWI-48, "DTC Index"](#).
2. When DTC is detected, follow the instructions below:
 - Record DTC and Freeze Frame Data.

Are self-diagnosis results normal?

YES >> GO TO 5.

NO >> GO TO 10.

5. NARROW DOWN THE MALFUNCTIONING PARTS BY SYMPTOM DIAGNOSIS

Perform symptom diagnosis and narrow down the malfunctioning parts.

>> GO TO 10.

6. CHECK METER CONTROL SWITCH SIGNAL CIRCUIT

Check meter control switch signal circuit. Refer to [MWI-72, "Diagnosis Procedure"](#).

Is inspection result OK?

YES >> GO TO 7.

NO >> GO TO 10.

7. CHECK METER CONTROL SWITCH

Check meter control switch. Refer to [MWI-72, "Component Inspection"](#).

Is inspection result OK?

YES >> GO TO 8.

NO >> GO TO 10.

8. CHECK COMBINATION METER POWER SUPPLY AND GROUND CIRCUITS

Check combination meter power supply and ground circuits. Refer to [MWI-71, "COMBINATION METER : Diagnosis Procedure"](#).

Is inspection result OK?

YES >> GO TO 9.

NO >> GO TO 10.

9. REPLACE COMBINATION METER

Replace combination meter.

>> GO TO 11.

10. REPAIR OR REPLACE MALFUNCTIONING PARTS

Repair or replace the malfunctioning parts.

NOTE:

If DTC is displayed, erase DTC after repair or replace malfunctioning parts.

>> GO TO 11.

DIAGNOSIS AND REPAIR WORKFLOW (METER SYSTEM)

< BASIC INSPECTION >

11.FINAL CHECK

Check that the combination meter operates normally.

Do they operate normally?

YES >> INSPECTION END

NO >> GO TO 1.

A

B

C

D

E

F

G

H

I

J

K

L

M

MWI

O

P

ZONE VARIATION SETTING (COMPASS)

< BASIC INSPECTION >

ZONE VARIATION SETTING (COMPASS)

Work Procedure

INFOID:0000000011324105

1. Press and hold the compass switch for 3 – 9 seconds.
2. The current zone setting appears on the compass display.
3. Find the current geographical location number in the zone variation chart.
4. Select the new zone number. (Press the compass switch until the new zone number appears on the compass display.)
5. After select the new zone number, the compass display will automatically shows a direction within a few seconds.
6. Perform the following calibration procedure for more accurate indications.

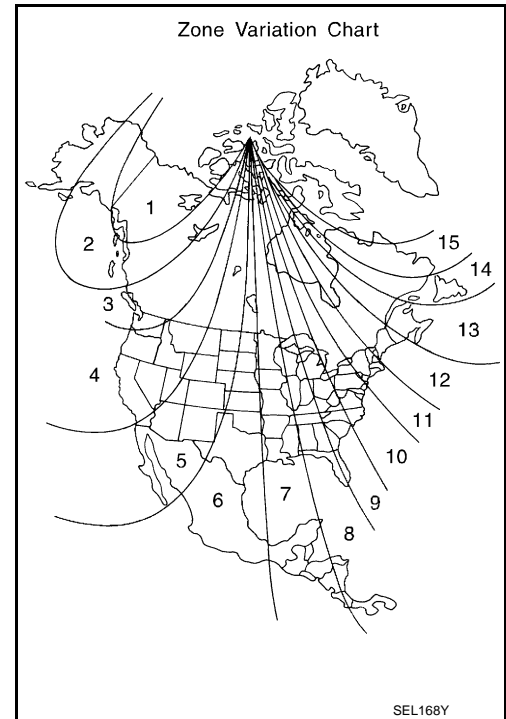

CALIBRATION (COMPASS)

< BASIC INSPECTION >

CALIBRATION (COMPASS)

Work Procedure

INFOID:000000011324106

NOTE:

The compass calibrates itself under normal driving conditions. However, occasional circumstances may cause the compass to operate inaccurately. Example: Driving from rural (wide open) areas to crowded city areas, or if an aftermarket (i.e., non original equipment) antenna with a magnetic base is attached to the vehicle. Calibrate the mirror compass if the display shows only one direction or a limited number of directions.

NOTE:

- If “magnetic hats” are used in the dealership for vehicle identification, remove the hat from the vehicle before performing the following steps. Do not put the hat back on the vehicle after the procedure is completed.
- Drive the vehicle to an open level area; away from large metallic objects, structures, and overhead power lines.
- Turn off “non-essential” electrical accessories (rear window defrost, heater/air conditioning, wipers) and close the doors.

1. Verify the correct compass zone setting for the geographical location. Refer to [MWI-64, "Work Procedure"](#).
2. Press and hold the compass switch for more than 9 seconds.
3. “C” is displayed on the compass display when calibration starts.
4. Drive slowly [less than 8 km/h (5 MPH)] in a circle until the “C / CAL” is replaced with primary headings (N, NE, E, SE, S, SW, W, or NW).

NOTE:

This will require driving at least 2 complete 360 degree circles, 3 complete circles may be required.

5. The compass calibration procedure is now complete. The compass should operate normally.

NOTE:

If at any time the compass continually displays the incorrect direction or the reading is erratic or locked, repeat the calibration procedure.

A
B
C
D
E
F
G
H
I
J
K
L
M
O
P

MWI

U1000 CAN COMM CIRCUIT

< DTC/CIRCUIT DIAGNOSIS >

DTC/CIRCUIT DIAGNOSIS

U1000 CAN COMM CIRCUIT

Description

INFOID:0000000011324107

CAN (Controller Area Network) is a serial communication system for real time application. It is an on-vehicle multiplex communication system with high data communication speed and excellent error detectability. Many electronic control units are equipped onto vehicles, and each control unit shares information and links with other control units during operation (not independent). In CAN communication, control units are connected with two communication lines (CAN-H line, CAN-L line) allowing a high rate of information transmission with less wiring. Each control unit transmits/receives data but selectively reads required data only.

CAN Communication Signal Chart. Refer to [LAN-32, "CAN COMMUNICATION SYSTEM : CAN Communication Signal Chart"](#).

DTC Logic

INFOID:0000000011324108

DTC DETECTION LOGIC

DTC	Display contents of CONSULT	Diagnostic item is detected when...	Probable malfunction location
U1000	CAN COMM CIRCUIT	When combination meter is not transmitting or receiving CAN communication signal for 2 seconds or more.	CAN communication system

Diagnosis Procedure

INFOID:0000000011324109

1. PERFORM SELF DIAGNOSTIC

1. Turn ignition switch ON and wait for 2 seconds or more.
2. Check "Self Diagnostic Result" of "METER/M&A".

Is "CAN COMM CIRCUIT" displayed?

- YES >> Refer to [LAN-17, "Trouble Diagnosis Flow Chart"](#).
NO >> Refer to [GI-42, "Intermittent Incident"](#).

U1010 CONTROL UNIT (CAN)

< DTC/CIRCUIT DIAGNOSIS >

U1010 CONTROL UNIT (CAN)

Description

INFOID:0000000011324110

Initial diagnosis of combination meter.

DTC Logic

INFOID:0000000011324111

DTC DETECTION LOGIC

DTC	Display contents of CONSULT	Diagnostic item is detected when...	Probable malfunction location
U1010	CONTROL UNIT (CAN)	When detecting error during the initial diagnosis of the CAN controller of combination meter.	Combination meter

Diagnosis Procedure

INFOID:0000000011324112

1. REPLACE COMBINATION METER

When DTC "U1010" is detected, replace combination meter.

>> INSPECTION END

A
B
C
D
E
F
G
H
I
J
K
L
M
O
P

MWI

B2205 VEHICLE SPEED

< DTC/CIRCUIT DIAGNOSIS >

B2205 VEHICLE SPEED

Description

INFOID:000000011324113

Vehicle speed signal is transmitted from ABS actuator and electric unit (control unit) via CAN communication to combination meter.

DTC Logic

INFOID:000000011324114

DTC DETECTION LOGIC

DTC	Display contents of CONSULT	Diagnostic item is detected when...	Probable malfunction location
B2205	VEHICLE SPEED	An abnormal vehicle speed signal is input from ABS actuator and electric unit (control unit) for 2 seconds or more	<ul style="list-style-type: none">• Wheel sensor• ABS actuator and electric unit (control unit)

Diagnosis Procedure

INFOID:000000011324115

1. PERFORM SELF-DIAGNOSIS OF ABS ACTUATOR AND ELECTRIC UNIT (CONTROL UNIT)

Perform "Self Diagnostic Result" of "ABS", and repair or replace malfunctioning parts.

>> Refer to [BRC-30, "CONSULT Function"](#).

B2267 ENGINE SPEED

< DTC/CIRCUIT DIAGNOSIS >

B2267 ENGINE SPEED

Description

INFOID:0000000011324116

The engine speed signal is transmitted from ECM to the combination meter via CAN communication.

DTC Logic

INFOID:0000000011324117

DTC DETECTION LOGIC

DTC	Display contents of CONSULT	Diagnostic item is detected when...	Probable malfunction location
B2267	ENGINE SPEED	ECM continuously transmits abnormal engine speed signals for 2 seconds or more	<ul style="list-style-type: none">• Crankshaft position sensor (POS)• ECM

Diagnosis Procedure

INFOID:0000000011324118

1. PERFORM SELF-DIAGNOSIS OF ECM

Perform "Self Diagnostic Result" of "ENGINE", and repair or replace malfunctioning parts.

>> Refer to [EC-103, "DTC Index"](#).

A
B
C
D
E
F
G
H
I
J
K
L
M
O
P

MWI

B2268 WATER TEMP

< DTC/CIRCUIT DIAGNOSIS >

B2268 WATER TEMP

Description

INFOID:000000011324119

The engine coolant temperature signal is transmitted from ECM to the combination meter via CAN communication.

DTC Logic

INFOID:000000011324120

DTC DETECTION LOGIC

DTC	Display contents of CONSULT	Diagnostic item is detected when...	Probable malfunction location
B2268	WATER TEMP	ECM continuously transmits abnormal engine coolant temperature signals for 60 seconds or more	<ul style="list-style-type: none">• Engine coolant temperature sensor• ECM

Diagnosis Procedure

INFOID:000000011324121

1. PERFORM SELF-DIAGNOSIS OF ECM

Perform "Self Diagnosis Result" of "ENGINE", and repair or replace malfunctioning parts.

>> Refer to [EC-103. "DTC Index"](#).

POWER SUPPLY AND GROUND CIRCUIT

< DTC/CIRCUIT DIAGNOSIS >

POWER SUPPLY AND GROUND CIRCUIT COMBINATION METER

COMBINATION METER : Diagnosis Procedure

INFOID:000000011324122

1. CHECK FUSE

Check for blown fuses.

Power source	Fuse No.
Battery	6
Ignition switch ON or START	4

Is the inspection result normal?

YES >> GO TO 2.

NO >> Be sure to eliminate cause of malfunction before installing new fuse.

2. CHECK POWER SUPPLY CIRCUIT

Check voltage between combination meter harness connector and ground.

Terminals		Ignition switch position	Voltage (Approx.)
(+)	(-)		
Combination meter		OFF	Battery voltage
Connector	Terminal		
M34	1		
	2		

Is the inspection result normal?

YES >> GO TO 3.

NO >> Check harness between combination meter and fuse.

3. CHECK GROUND CIRCUIT

1. Turn ignition switch OFF.
2. Disconnect combination meter connector.
3. Check continuity between combination meter harness connector and ground.

Combination meter		Ground	Continuity
Connector	Terminal		
M34	3	Ground	Existed
	4		
	23		

Is the inspection result normal?

YES >> INSPECTION END

NO >> Repair harness or connector.

A
B
C
D
E
F
G
H
I
J
K
L
M
O
P

MWI

METER CONTROL SWITCH SIGNAL CIRCUIT

< DTC/CIRCUIT DIAGNOSIS >

METER CONTROL SWITCH SIGNAL CIRCUIT

Diagnosis Procedure

INFOID:000000011324123

1. CHECK COMBINATION METER INPUT SIGNAL

1. Turn ignition switch ON.
2. Measure voltage between the following terminals of the combination meter.

Combination meter		Condition	Voltage (Approx.)
Connector	Terminals		
	(+) (-)		
M34	11	When enter switch is pressed	0 V
		Other than the above	5 V
	12	When select switch is pressed	0 V
		Other than the above	5 V
	8	When trip reset switch is pressed	0 V
		Other than the above	5 V

Is the inspection result normal?

YES >> INSPECTION END

NO >> GO TO 2.

2. CHECK METER CONTROL SWITCH SIGNAL CIRCUIT

1. Turn ignition switch OFF.
2. Disconnect combination meter connector and meter control switch connector.
3. Check continuity between combination meter harness connector and meter control switch harness connector.

Terminals				Continuity
Combination meter		Meter control switch		
Connector	Terminal	Connector	Terminal	
M34	8	M54	5	Existed
	10		6	
	11		3	
	12		4	

4. Check continuity between combination meter harness connector and ground.

Combination meter		Ground	Continuity
Connector	Terminal		
M34	8	Ground	Not existed
	10		
	11		
	12		

Is the inspection result normal?

YES >> INSPECTION END

NO >> Repair harness or connector.

Component Inspection

INFOID:000000011324124

1. CHECK METER CONTROL SWITCH

1. Turn ignition switch OFF.

METER CONTROL SWITCH SIGNAL CIRCUIT

< DTC/CIRCUIT DIAGNOSIS >

2. Disconnect meter control switch connector.
3. Check meter control switch.

Terminals		Condition	Continuity
Meter control switch			
3	6	When enter switch is pressed	Existed
		Other than the above	Not existed
4		When select switch is pressed	Existed
		Other than the above	Not existed
5		When trip reset switch is pressed	Existed
		Other than the above	Not existed

Is the inspection result normal?

YES >> INSPECTION END

NO >> Replace meter control switch. Refer to [MWI-92. "Removal and Installation"](#).

A
B
C
D
E
F
G
H
I
J
K
L
M
O
P

MWI

ILLUMINATION CONTROL SWITCH SIGNAL CIRCUIT

< DTC/CIRCUIT DIAGNOSIS >

ILLUMINATION CONTROL SWITCH SIGNAL CIRCUIT

Diagnosis Procedure

INFOID:000000011324125

1. CHECK COMBINATION METER INPUT SIGNAL

1. Turn ignition switch ON.
2. Measure voltage between the following terminals of the combination meter.

Combination meter			Condition	Voltage (Approx.)
Connector	Terminals			
	(+)	(-)		
M34	13	10	When illumination control switch (+) is pressed	0 V
			Other than the above	5 V
	14		When illumination control switch (-) is pressed	0 V
			Other than the above	5 V

Is the inspection result normal?

- YES >> INSPECTION END
 NO >> GO TO 2.

2. CHECK ILLUMINATION CONTROL SWITCH SIGNAL CIRCUIT

1. Turn ignition switch OFF.
2. Disconnect combination meter connector and illumination control switch connector.
3. Check continuity between combination meter harness connector and illumination control switch harness connector.

Terminals				Continuity
Combination meter		Meter control switch		
Connector	Terminal	Connector	Terminal	
M34	10	M55	6	Existed
	13		3	
	14		4	

4. Check continuity between combination meter harness connector and ground.

Combination meter		Ground	Continuity
Connector	Terminal		
M34	10		Not existed
	13		
	14		

Is the inspection result normal?

- YES >> INSPECTION END
 NO >> Repair harness or connector.

Component Inspection

INFOID:000000011324126

1. CHECK ILLUMINATION CONTROL SWITCH

1. Turn ignition switch OFF.
2. Disconnect illumination control switch connector.
3. Check meter control switch.

ILLUMINATION CONTROL SWITCH SIGNAL CIRCUIT

< DTC/CIRCUIT DIAGNOSIS >

Terminals		Condition	Continuity
Meter control switch			
3	6	When illumination control switch (+) is pressed	Existed
		Other than the above	Not existed
4		When illumination control switch (-) is pressed	Existed
		Other than the above	Not existed

Is the inspection result normal?

YES >> INSPECTION END

NO >> Replace illumination control switch. Refer to [MWI-92, "Removal and Installation"](#).

A
B
C
D
E
F
G
H
I
J
K
L
M
N
O
P

MWI

FUEL LEVEL SENSOR SIGNAL CIRCUIT

< DTC/CIRCUIT DIAGNOSIS >

FUEL LEVEL SENSOR SIGNAL CIRCUIT

Description

INFOID:0000000011324127

The fuel level sensor unit and fuel pump (fuel level sensor) detect the fuel level in the fuel tank and transmit the fuel gauge signal to the combination meter.

Component Function Check

INFOID:0000000011324128

1.PERFORM COMPONENT FUNCTION CHECK (1)

1. Turn ignition switch OFF.
2. Disconnect fuel level sensor unit and fuel pump (fuel level sensor) connector.
3. Connect variable resistor between harness connector terminals located on the vehicle side of the fuel level sensor unit and fuel pump (fuel level sensor).

Fuel level sensor unit and fuel pump (fuel level sensor)		
Connector	Terminals	
B40	2	5

4. Set variable resistor according to the resistance value shown in the following table and turn ignition switch ON.

Resistance (Ω)* (Approx.)	Fuel gauge indication position (Approx.)
Less than 94	Full
140	3/4
186	1/2
232	1/4
More than 278	Empty

*: Reference resistance values used when the combination meter judges the indication position of the fuel gauge.

Is the inspection result normal?

- YES >> GO TO 2.
NO >> Refer to [MWI-76, "Diagnosis Procedure"](#).

2.PERFORM COMPONENT FUNCTION CHECK (2)

Check the fuel level sensor unit and fuel pump (fuel level sensor). Refer to [MWI-77, "Component Inspection"](#).

Is the inspection result normal?

- YES >> INSPECTION END
NO >> Replace the fuel level sensor unit and fuel pump (fuel level sensor). Refer to [FL-5, "Removal and Installation"](#).

Diagnosis Procedure

INFOID:0000000011324129

1.CHECK FUEL LEVEL SENSOR UNIT AND FUEL PUMP (FUEL LEVEL SENSOR) CIRCUIT

1. Turn ignition switch OFF.
2. Disconnect combination meter connector and fuel level sensor unit and fuel pump (fuel level sensor) connector.
3. Check continuity between combination meter harness connector and fuel level sensor unit and fuel pump (fuel level sensor) harness connector.

Combination meter		Fuel level sensor unit and fuel pump (fuel level sensor)		Continuity
Connector	Terminal	Connector	Terminal	
M34	34	B40	2	Existed

FUEL LEVEL SENSOR SIGNAL CIRCUIT

< DTC/CIRCUIT DIAGNOSIS >

4. Check continuity between combination meter harness connector and ground.

Combination meter		Ground	Continuity
Connector	Terminal		
M34	34		Not existed

Is the inspection result normal?

YES >> GO TO 2.

NO >> Repair harness or connector.

2. CHECK FUEL LEVEL SENSOR UNIT AND FUEL PUMP (FUEL LEVEL SENSOR) GROUND CIRCUIT

1. Check continuity between fuel level sensor unit and fuel pump (fuel level sensor) harness connector and combination meter harness connector.

Fuel level sensor unit and fuel pump (fuel level sensor)		Combination meter		Continuity
Connector	Terminal	Connector	Terminal	
B40	5	M34	24	Existed

2. Check continuity between fuel level sensor unit and fuel pump (fuel level sensor) harness connector and ground.

Fuel level sensor unit and fuel pump (fuel level sensor)		Ground	Continuity
Connector	Terminal		
B40	5		Not existed

Is the inspection result normal?

YES >> Replace combination meter. Refer to [MWI-90, "Removal and Installation"](#).

NO >> Repair harness or connector.

Component Inspection

INFOID:0000000011324130

1. CHECK FUEL LEVEL SENSOR UNIT AND FUEL PUMP (FUEL LEVEL SENSOR)

1. Remove the fuel level sensor unit and fuel pump (fuel level sensor). Refer to [FL-5, "Removal and Installation"](#).
2. Check the resistance between fuel level sensor unit and fuel pump (fuel level sensor).

Terminals		Condition	Resistance (Ω) (Approx.)	Height [mm (in)]
Fuel level sensor unit and fuel pump (fuel level sensor)				
2	5	Full* (A)	51	133.0 (5.24)
		Empty* (B)	283	15.7 (0.618)

*: When float rod is contact with stopper.

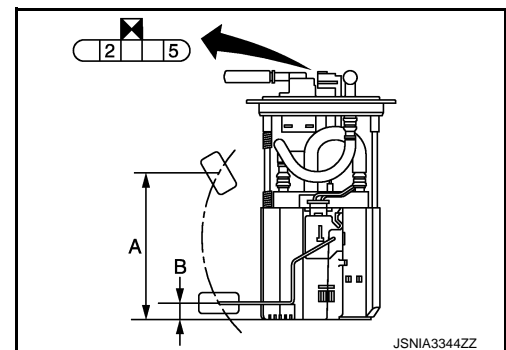

Is inspection result OK?

YES >> INSPECTION END

NO >> Replace fuel level sensor unit and fuel pump (fuel level sensor). Refer to [FL-5, "Removal and Installation"](#).

WASHER LEVEL SWITCH SIGNAL CIRCUIT

< DTC/CIRCUIT DIAGNOSIS >

WASHER LEVEL SWITCH SIGNAL CIRCUIT

Diagnosis Procedure

INFOID:000000011324134

1. CHECK WASHER LEVEL SWITCH SIGNAL CIRCUIT

1. Turn ignition switch OFF.
2. Disconnect combination meter connector and washer level switch connector.
3. Check continuity between combination meter harness connector and washer level switch harness connector.

Terminals				Continuity
Combination meter		Washer level switch		
Connector	Terminal	Connector	Terminal	
M34	29	E303	1	Existed

4. Check continuity between combination meter harness connector and ground.

Terminals			Continuity
Combination meter		Ground	
Connector	Terminal		
M34	29		Not existed

Is the inspection result normal?

- YES >> GO TO 2.
NO >> Repair harness or connector.

2. CHECK WASHER LEVEL SWITCH GROUND CIRCUIT

Check continuity between washer level switch connector and ground.

Terminals			Continuity
Washer level switch		Ground	
Connector	Terminal		
E303	2		Existed

Is the inspection result normal?

- YES >> INSPECTION END
NO >> Repair harness or connector.

Component Inspection

INFOID:000000011324135

1. CHECK WASHER LEVEL SWITCH

1. Turn ignition switch OFF.
2. Disconnect washer level switch connector.
3. Check washer level switch.

Terminals		Condition	Continuity
Washer level switch			
1	2	Washer level switch ON	Existed
		Washer level switch OFF	Not existed

Is the inspection result normal?

- YES >> INSPECTION END
NO >> Replace washer level switch. Refer to [WW-71, "Removal and Installation"](#).

A/C AUTO AMP. CONNECTION RECOGNITION SIGNAL CIRCUIT

< DTC/CIRCUIT DIAGNOSIS >

A/C AUTO AMP. CONNECTION RECOGNITION SIGNAL CIRCUIT

Diagnosis Procedure

INFOID:000000011324136

1. CHECK A/C AUTO AMP. CONNECTION RECOGNITION SIGNAL

1. Turn ignition switch ON.
2. Check voltage between combination meter harness connector and ground.

Terminals		Voltage (Approx.)
(+)	(-)	
Combination meter		Ground
Connector	Terminal	
M34	19	
		5 V

Is the inspection result normal?

- YES >> INSPECTION END
NO >> GO TO 2.

2. CHECK A/C AUTO AMP. CONNECTION RECOGNITION SIGNAL CIRCUIT

1. Turn ignition switch OFF.
2. Disconnect combination meter connector and A/C auto amp. connector.
3. Check continuity between combination meter harness connector and A/C auto amp. harness connector.

Combination meter		A/C auto amp.		Continuity
Connector	Terminal	Connector	terminal	
M34	19	M50	20	Existed

4. Check continuity between combination meter harness connector and ground.

Combination meter		Ground	Continuity
Connector	Terminal		
M34	19		Not existed

Is the inspection result normal?

- YES >> INSPECTION END
NO >> Repair harness or connector.

A
B
C
D
E
F
G
H
I
J
K
L
M
O
P



THE FUEL GAUGE INDICATOR DOES NOT OPERATE

< SYMPTOM DIAGNOSIS >

SYMPTOM DIAGNOSIS

THE FUEL GAUGE INDICATOR DOES NOT OPERATE

Description

INFOID:0000000011324137

Fuel gauge will not indicate from a certain position.

Diagnosis Procedure

INFOID:0000000011324138

1. CONDUCTING THE COMBINATION METER SELF-DIAGNOSIS MODE

Perform the self-diagnosis mode of combination meter, and then check that the fuel gauge operates normally. Refer to [MWI-34, "On Board Diagnosis Function"](#).

Is the inspection result normal?

YES >> GO TO 2.

NO >> Replace the combination meter.

2. CHECK FLOAT INTERFERENCE

Check that the float arm interferes with or binds to other components in the fuel tank.

Is the inspection result normal?

YES >> GO TO 3.

NO >> Repair or replace malfunctioning part.

3. CHECK FUEL LEVEL SENSOR SIGNAL CIRCUIT

Check the fuel level sensor signal circuit. Refer to [MWI-76, "Component Function Check"](#).

Is the inspection result normal?

YES >> Check intermittent incident. Refer to [GI-42, "Intermittent Incident"](#).

NO >> Repair or replace malfunctioning parts.

THE METER CONTROL SWITCH IS INOPERATIVE

< SYMPTOM DIAGNOSIS >

THE METER CONTROL SWITCH IS INOPERATIVE

Description

INFOID:000000011324139

If any of the following malfunctions is found for the meter control switch operation.

- All switches are inoperative
- The specified switch cannot be operated

Diagnosis Procedure

INFOID:000000011324140

1. CHECK METER CONTROL SWITCH SIGNAL CIRCUIT

Check the meter control switch signal circuit. Refer to [MWI-72, "Diagnosis Procedure"](#).

Is the inspection result normal?

YES >> GO TO 2.

NO >> Repair harness or connector.

2. CHECK METER CONTROL SWITCH

Perform a unit check for the meter control switch. Refer to [MWI-72, "Component Inspection"](#).

Is the inspection result normal?

YES >> Replace combination meter. Refer to [MWI-90, "Removal and Installation"](#).

NG >> Replace meter control switch. Refer to [MWI-92, "Removal and Installation"](#).

A
B
C
D
E
F
G
H
I
J
K
L
M
O
P

MWI

THE ILLUMINATION CONTROL SWITCH IS INOPERATIVE

< SYMPTOM DIAGNOSIS >

THE ILLUMINATION CONTROL SWITCH IS INOPERATIVE

Description

INFOID:000000011324141

If any of the following malfunctions is found for the illumination control switch operation.

- All switches are inoperative
- The specified switch cannot be operated

Diagnosis Procedure

INFOID:000000011324142

1. CHECK ILLUMINATION CONTROL SWITCH SIGNAL CIRCUIT

Check the illumination control switch signal circuit. Refer to [MWI-72, "Diagnosis Procedure"](#).

Is the inspection result normal?

YES >> GO TO 2.

NO >> Repair harness or connector.

2. CHECK ILLUMINATION CONTROL SWITCH

Perform a unit check for the illumination control switch. Refer to [MWI-72, "Component Inspection"](#).

Is the inspection result normal?

YES >> Replace combination meter. Refer to [MWI-90, "Removal and Installation"](#).

NG >> Replace illumination control switch. Refer to [MWI-92, "Removal and Installation"](#).

THE OIL PRESSURE WARNING LAMP DOES NOT TURN ON

< SYMPTOM DIAGNOSIS >

THE OIL PRESSURE WARNING LAMP DOES NOT TURN ON

Description

INFOID:0000000011324143

The oil pressure warning lamp stays off when the ignition switch is turned ON.

Diagnosis Procedure

INFOID:0000000011324144

1. CHECK COMBINATION METER INPUT SIGNAL

-
1. Start the engine.
 2. Select "Data Monitor" in "METER/M&A" to check that the oil pressure warning lamp state is consistent with the "OIL W/L" monitor value.

Is the inspection result normal?

YES >> INSPECTION END

NO >> Replace combination meter. Refer to [MWI-90, "Removal and Installation"](#).

A
B
C
D
E
F
G
H
I
J
K
L
M
O
P

MWI

THE OIL PRESSURE WARNING LAMP DOES NOT TURN OFF

< SYMPTOM DIAGNOSIS >

THE OIL PRESSURE WARNING LAMP DOES NOT TURN OFF

Description

INFOID:0000000011324145

The oil pressure warning lamp remains illuminated while the engine is running (normal oil pressure).

Diagnosis Procedure

INFOID:0000000011324146

1.CHECK COMBINATION METER INPUT SIGNAL

1. Start the engine.
2. Select "Data Monitor" in "METER/M&A" to check that the oil pressure warning lamp state is consistent with the "OIL W/L" monitor value.

Is the inspection result normal?

YES >> INSPECTION END

NO >> Replace combination meter. Refer to [MWI-90. "Removal and Installation"](#).

THE PARKING BRAKE RELEASE WARNING CONTINUES DISPLAYING, OR DOES NOT DISPLAY

< SYMPTOM DIAGNOSIS >

THE PARKING BRAKE RELEASE WARNING CONTINUES DISPLAYING, OR DOES NOT DISPLAY

Description

INFOID:0000000011324147

- The parking brake warning is displayed during vehicle travel even though the parking brake is released.
- The parking brake warning is not displayed even though driving the vehicle with the parking brake applied.

Diagnosis Procedure

INFOID:0000000011324148

1. CHECK PARKING BRAKE WARNING LAMP OPERATION

1. Start engine.
2. Check the operation of the brake warning lamp when operating the parking brake.

Condition	Warning lamp status
Parking brake applied	ON
Parking brake released	OFF

Is the inspection result normal?

- YES >> Replace combination meter. Refer to [MWI-90, "Removal and Installation"](#).
NO >> GO TO 2.

2. CHECK PARKING BRAKE SWITCH SIGNAL CIRCUIT

1. Turn ignition switch OFF.
2. Check the parking brake switch signal circuit. Refer to [WCS-43, "Diagnosis Procedure"](#).

Is the inspection result normal?

- YES >> GO TO 3.
NO >> Repair harness or connector.

3. CHECK PARKING BRAKE SWITCH UNIT

Perform a unit check for the parking brake switch. Refer to [BRC-104, "Component Inspection"](#).

Is the inspection result normal?

- YES >> Replace combination meter. Refer to [MWI-90, "Removal and Installation"](#).
NO >> Replace parking brake switch. Refer to [PB-7, "Exploded View"](#).

A
B
C
D
E
F
G
H
I
J
K
L
M
O
P

MWI

THE LOW WASHER FLUID WARNING CONTINUES DISPLAYING, OR DOES NOT DISPLAY

< SYMPTOM DIAGNOSIS >

THE LOW WASHER FLUID WARNING CONTINUES DISPLAYING, OR DOES NOT DISPLAY

Description

INFOID:000000011324149

- The warning is still displayed even after washer fluid is added.
- The warning is not displayed even though the washer tank is empty.

Diagnosis Procedure

INFOID:000000011324150

1. CHECK WASHER LEVEL SWITCH SIGNAL CIRCUIT

Check the washer level switch signal circuit. Refer to [MWI-78. "Diagnosis Procedure"](#).

Is the inspection result normal?

- YES >> GO TO 2.
NO >> Repair harness or connector.

2. CHECK WASHER LEVEL SWITCH UNIT

Perform a unit check for the washer level switch. Refer to [MWI-78. "Component Inspection"](#).

Is the inspection result normal?

- YES >> Replace combination meter. Refer to [MWI-90. "Removal and Installation"](#).
NO >> Replace washer level switch. Refer to [WW-71. "Removal and Installation"](#).

THE DOOR OPEN WARNING CONTINUES DISPLAYING, OR DOES NOT DISPLAY

< SYMPTOM DIAGNOSIS >

THE DOOR OPEN WARNING CONTINUES DISPLAYING, OR DOES NOT DISPLAY

Description

INFOID:0000000011324151

- The door ajar warning is displayed even though all of the doors are closed.
- The door ajar warning is not displayed even though a door is ajar.

Diagnosis Procedure

INFOID:0000000011324152

1. CHECK BCM INPUT/OUTPUT SIGNAL

Connect CONSULT and check the BCM input signals. Refer to [DLK-241, "Component Function Check"](#).

Is the inspection result normal?

YES >> GO TO 2.

NO >> GO TO 3.

2. CHECK COMBINATION METER INPUT SIGNAL

Select the "Data Monitor" for the "METER/M&A" and check the "DOOR W/L" monitor value.

"DOOR W/L"

Door open : On

Door closed : Off

Is the inspection result normal?

YES >> Replace combination meter. Refer to [MWI-90, "Removal and Installation"](#).

NO >> Replace BCM. Refer to [BCS-98, "Removal and Installation"](#).

3. CHECK DOOR SWITCH SIGNAL CIRCUIT

Check the door switch signal circuit. Refer to [DLK-241, "Diagnosis Procedure"](#).

Is the inspection result normal?

YES >> GO TO 4.

NO >> Repair harness or connector.

4. CHECK DOOR SWITCH

Perform a unit check for the door switch. Refer to [DLK-242, "Component Inspection"](#).

Is the inspection result normal?

YES >> Replace combination meter. Refer to [MWI-90, "Removal and Installation"](#).

NO >> Replace applicable door switch. Refer to [DLK-479, "Removal and Installation"](#).

A
B
C
D
E
F
G
H
I
J
K
L
M

MWI

O
P

THE AMBIENT TEMPERATURE DISPLAY IS INCORRECT

< SYMPTOM DIAGNOSIS >

THE AMBIENT TEMPERATURE DISPLAY IS INCORRECT

Description

INFOID:000000011324153

- The displayed ambient air temperature is higher than the actual temperature.
- The displayed ambient air temperature is lower than the actual temperature.

Diagnosis Procedure

INFOID:000000011324154

NOTE:

Check that the symptom is not applicable to the normal operating condition before starting diagnosis. Refer to [MWI-89, "INFORMATION DISPLAY : Description"](#).

1.CHECK AMBIENT SENSOR SIGNAL CIRCUIT

Check the ambient sensor signal circuit. Refer to [HAC-94, "Diagnosis Procedure"](#).

Is the inspection result normal?

YES >> GO TO 2.

NO >> Repair harness or connector.

2.CHECK AMBIENT SENSOR

Perform the part check for the ambient sensor. Refer to [HAC-95, "Component Inspection"](#).

Is the inspection result normal?

YES >> Replace combination meter. Refer to [MWI-90, "Removal and Installation"](#).

NO >> Replace ambient sensor. Refer to [HAC-145, "Removal and Installation"](#).

NORMAL OPERATING CONDITION

< SYMPTOM DIAGNOSIS >

NORMAL OPERATING CONDITION COMPASS

COMPASS : Description

INFOID:000000011324155

COMPASS

- The electronic compass is highly protected from changes in most magnetic fields. However, some large changes in magnetic fields can affect it. Some examples are (but not limited to): high tension power lines, large steel buildings, subways, steel bridges, automatic car washes, large piles of scrap metal, etc. While this does not happen very often, it is possible.
- During normal operation, the compass mirror will continuously update the compass calibration to adjust for gradual changes in the vehicle's magnetic "remnant" field. If the vehicle is subjected to high magnetic influences, the compass may appear to indicate false headings, become locked, or appear that it is unable to be calibrated. If this occurs, perform the calibration procedure.
- If at any time the compass continually displays an incorrect direction or the reading is erratic or locked, verify the correct zone variance.

Symptom Chart

Symptom	Cause	Solution / Reference
The compass display reads "C".	<ul style="list-style-type: none">• Compass is not calibrated.• Incorrect zone variance setting.• Large change in magnetic field (Steel bridges, subways, concentrations of metal, carwashes, etc.)• Compass was calibrated incorrectly or in the presence of a strong magnetic field.	Perform Calibration. Refer to MWI-65, "Work Procedure" .
Compass shows the wrong direction.		
Compass does not change direction appears "Locked".		
Compass does not show all the directions, one or more is missing.		
The compass was calibrated but it "loses" calibration.		
On long trips the compass shows the wrong direction.	Perform zone variation setting if correct reading is desired in that location. Refer to MWI-64, "Work Procedure" .	

INFORMATION DISPLAY

INFORMATION DISPLAY : Description

INFOID:000000011324156

AMBIENT TEMPERATURE

The displayed ambient temperature on the information display may differ from the actual temperature because it is a corrected value calculated from the ambient sensor signal by the combination meter. Refer to [MWI-21, "INFORMATION DISPLAY : System Description"](#) for details on the correction process.

DISTANCE TO EMPTY

The calculated distance to empty may differ from the actual distance to empty if the refueling amount is approximately 15 ℓ (4 US gal, 3-1/4 Imp gal) or less. This is because the refuel control (moves the fuel gauge needle quicker than normal judging that the driver is refueling the vehicle) is not performing.

A
B
C
D
E
F
G
H
I
J
K
L
M
O
P

MWI

COMBINATION METER

< REMOVAL AND INSTALLATION >

REMOVAL AND INSTALLATION

COMBINATION METER

Exploded View

INFOID:0000000011324157

REMOVAL

Refer to [IP-12, "Exploded View"](#).

DISASSEMBLY

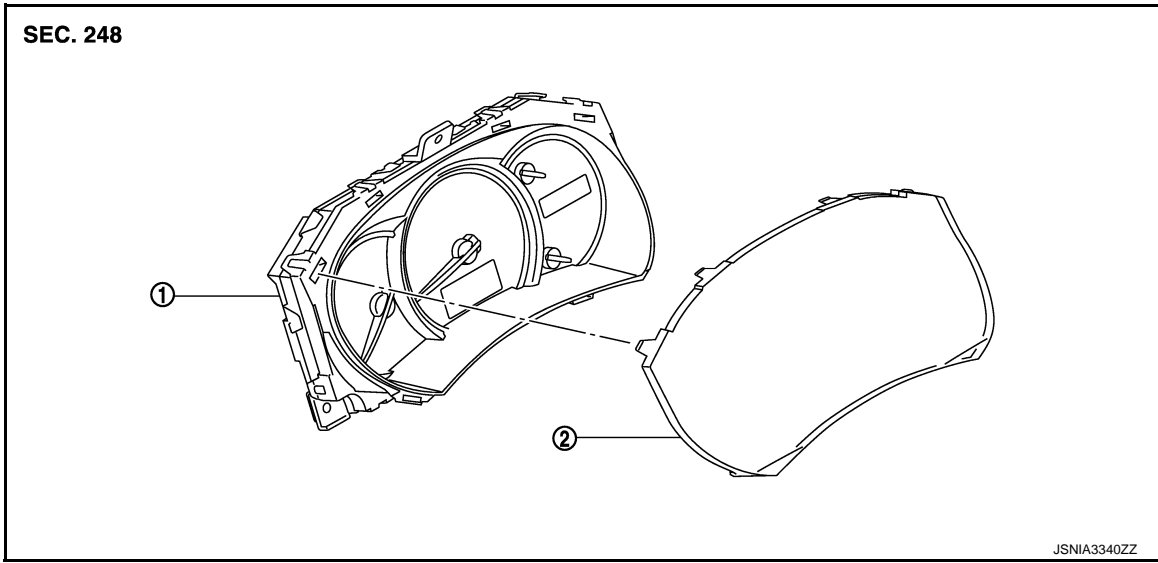

1. Unified meter control unit
2. Front cover

Removal and Installation

INFOID:0000000011324158

REMOVAL

1. Remove the cluster lid A. Refer to [IP-14, "Removal and Installation"](#).
2. Remove screws and connector, and then remove combination meter.

INSTALLATION

Install in the reverse order of removal.

Disassembly and Assembly

INFOID:0000000011324159

DISASSEMBLY

1. Disengage the pawls (4 on the lower part) of the combination meter.
2. Insert the removal tool into the clearance (in the order of A, B) between the front cover and the meter control unit. Remove 4 pawls on the lower side of the front cover by turning the tool while increasing the clearance.

CAUTION:

Wrap the removal tools with protective tape to prevent scratches.

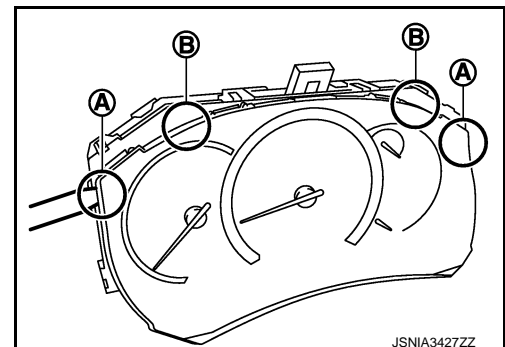

3. Pull the front cover straight to remove it from the unified meter control unit.

CAUTION:

COMBINATION METER

< REMOVAL AND INSTALLATION >

- **Never touch the display, pointer, the inside of front cover and the printed area of the dial during the work.**
- **Keep away from magnetic sources.**
- **Never damage the front cover.**

A

ASSEMBLY

Install the front cover straight to the unified meter control unit and engage all the pawl.

CAUTION:

- **Never touch the display, pointer, the inside of front cover and the printed area of the dial during the work.**
- **Keep away from magnetic sources.**
- **Never damage the front cover.**

B

C

D

E

F

G

H

I

J

K

L

M

MWI

O

P

METER CONTROL SWITCH

< REMOVAL AND INSTALLATION >

METER CONTROL SWITCH

Exploded View

INFOID:000000011324160

REMOVAL

Refer to [IP-12. "Exploded View"](#).

Removal and Installation

INFOID:000000011324161

REMOVAL

1. Remove cluster lid A. Refer to [IP-14. "Removal and Installation"](#).
2. Disengage the tabs and remove meter control switch.

INSTALLATION

Install in the reverse order of removal.

ILLUMINATION CONTROL SWITCH

< REMOVAL AND INSTALLATION >

ILLUMINATION CONTROL SWITCH

Exploded View

INFOID:000000011324162

REMOVAL

Refer to [IP-12. "Exploded View"](#).

Removal and Installation

INFOID:000000011324163

REMOVAL

1. Remove cluster lid A. Refer to [IP-14. "Removal and Installation"](#).
2. Disengage the tabs and remove illumination control switch.

INSTALLATION

Install in the reverse order of removal.

A
B
C
D
E
F
G
H
I
J
K
L
M
O
P

MWI

COMPASS

< REMOVAL AND INSTALLATION >

COMPASS

Exploded View

INFOID:000000011324164

Refer to [MIR-29. "Exploded View"](#) (with ADP), or [MIR-47. "Exploded View"](#) (without ADP).

Removal and Installation

INFOID:000000011324165

Refer to [MIR-29. "Removal and Installation"](#) (with ADP), or [MIR-47. "Removal and Installation"](#) (without ADP).