

SECTION **PWO**
POWER OUTLET

A
B
C

CONTENTS

D
E

POWER SOCKET

PRECAUTION 3

PRECAUTIONS 3

 Precaution for Supplemental Restraint System (SRS) "AIR BAG" and "SEAT BELT PRE-TENSIONER"3

 Precautions for Removing Battery Terminal3

WIRING DIAGRAM 4

POWER SOCKET 4

 Wiring Diagram4

REMOVAL AND INSTALLATION 6

POWER SOCKET 6

FRONT POWER SOCKET6

 FRONT POWER SOCKET : Exploded View6

 FRONT POWER SOCKET : Removal and Installation6

LUGGAGE ROOM POWER SOCKET7

 LUGGAGE ROOM POWER SOCKET : Exploded View7

 LUGGAGE ROOM POWER SOCKET : Removal and Installation7

SERVICE DATA AND SPECIFICATIONS (SDS) 9

SERVICE DATA AND SPECIFICATIONS (SDS) 9

 Power Socket9

AC 120 V OUTLET

PRECAUTION10

PRECAUTIONS10

 Precaution for Supplemental Restraint System (SRS) "AIR BAG" and "SEAT BELT PRE-TENSIONER"10

 Precautions for Removing Battery Terminal10

SYSTEM DESCRIPTION11

COMPONENT PARTS11

 Component Parts Location11

 AC 120 V Outlet Main Switch11

 AC 120 V Outlet12

 Inverter Unit12

SYSTEM13

 System Description13

 Circuit Diagram14

 Fail-safe14

ECU DIAGNOSIS INFORMATION16

INVERTER UNIT16

 Reference Value16

 Fail-safe17

WIRING DIAGRAM18

AC 120 V POWER OUTLET18

 Wiring Diagram18

BASIC INSPECTION21

DIAGNOSIS AND REPAIR WORK FLOW21

 Work Flow21

DTC/CIRCUIT DIAGNOSIS23

POWER SUPPLY AND GROUND CIRCUIT23

 Diagnosis Procedure23

AC 120 V OUTLET MAIN SWITCH POWER SUPPLY CIRCUIT24

 Diagnosis Procedure24

F
G
H
I
J
K
L

PWO

N
O
P

AC 120 V OUTLET MAIN SWITCH INPUT SIGNAL CIRCUIT	25	NORMAL OPERATING CONDITION	33
Diagnosis Procedure	25	Description	33
Component Inspection	25	REMOVAL AND INSTALLATION	34
AC 120 V POWER OUTPUT CIRCUIT	27	INVERTER UNIT	34
Diagnosis Procedure	27	Removal and Installation	34
AC 120 V OUTLET MAIN SWITCH INDICATOR CIRCUIT	29	AC 120V OUTLET MAIN SW	35
Diagnosis Procedure	29	Removal and Installation	35
SYMPTOM DIAGNOSIS	31	AC 120 V OUTLET	36
NO OUTPUT FROM AC 120 V OUTLET	31	Removal and Installation	36
Diagnosis Procedure	31	SERVICE DATA AND SPECIFICATIONS (SDS)	37
AC 120 V OUTLET MAIN SWITCH INDICATOR DOES NOT TURN ON	32	SERVICE DATA AND SPECIFICATIONS (SDS)	37
Diagnosis Procedure	32	AC 120 V Power Outlet	37

PRECAUTION

PRECAUTIONS

Precaution for Supplemental Restraint System (SRS) "AIR BAG" and "SEAT BELT PRE-TENSIONER"

INFOID:000000011326172

The Supplemental Restraint System such as "AIR BAG" and "SEAT BELT PRE-TENSIONER", used along with a front seat belt, helps to reduce the risk or severity of injury to the driver and front passenger for certain types of collision. This system includes seat belt switch inputs and dual stage front air bag modules. The SRS system uses the seat belt switches to determine the front air bag deployment, and may only deploy one front air bag, depending on the severity of a collision and whether the front occupants are belted or unbelted. Information necessary to service the system safely is included in the "SRS AIR BAG" and "SEAT BELT" of this Service Manual.

WARNING:

Always observe the following items for preventing accidental activation.

- To avoid rendering the SRS inoperative, which could increase the risk of personal injury or death in the event of a collision that would result in air bag inflation, all maintenance must be performed by an authorized NISSAN/INFINITI dealer.
- Improper maintenance, including incorrect removal and installation of the SRS, can lead to personal injury caused by unintentional activation of the system. For removal of Spiral Cable and Air Bag Module, see "SRS AIR BAG".
- Never use electrical test equipment on any circuit related to the SRS unless instructed to in this Service Manual. SRS wiring harnesses can be identified by yellow and/or orange harnesses or harness connectors.

PRECAUTIONS WHEN USING POWER TOOLS (AIR OR ELECTRIC) AND HAMMERS

WARNING:

Always observe the following items for preventing accidental activation.

- When working near the Air Bag Diagnosis Sensor Unit or other Air Bag System sensors with the ignition ON or engine running, never use air or electric power tools or strike near the sensor(s) with a hammer. Heavy vibration could activate the sensor(s) and deploy the air bag(s), possibly causing serious injury.
- When using air or electric power tools or hammers, always switch the ignition OFF, disconnect the battery, and wait at least 3 minutes before performing any service.

Precautions for Removing Battery Terminal

INFOID:000000011326173

- When removing the 12V battery terminal, turn OFF the ignition switch and wait at least 30 seconds.

NOTE:

ECU may be active for several tens of seconds after the ignition switch is turned OFF. If the battery terminal is removed before ECU stops, then a DTC detection error or ECU data corruption may occur.

- For vehicles with the 2-batteries, be sure to connect the main battery and the sub battery before turning ON the ignition switch.

NOTE:

If the ignition switch is turned ON with any one of the terminals of main battery and sub battery disconnected, then DTC may be detected.

- After installing the 12V battery, always check "Self Diagnosis Result" of all ECUs and erase DTC.

NOTE:

The removal of 12V battery may cause a DTC detection error.

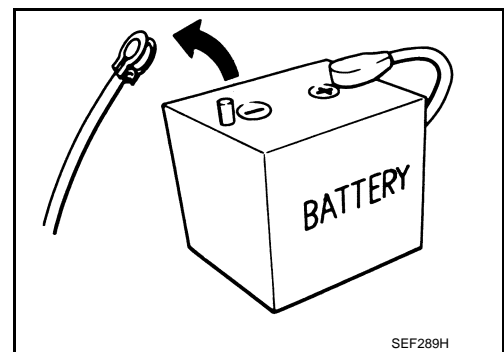

A
B
C
D
E
F
G
H
I
J
K
L
PWO
N
O
P

POWER SOCKET

< WIRING DIAGRAM >

[POWER SOCKET]

WIRING DIAGRAM

POWER SOCKET

Wiring Diagram

INFOID:000000011326174

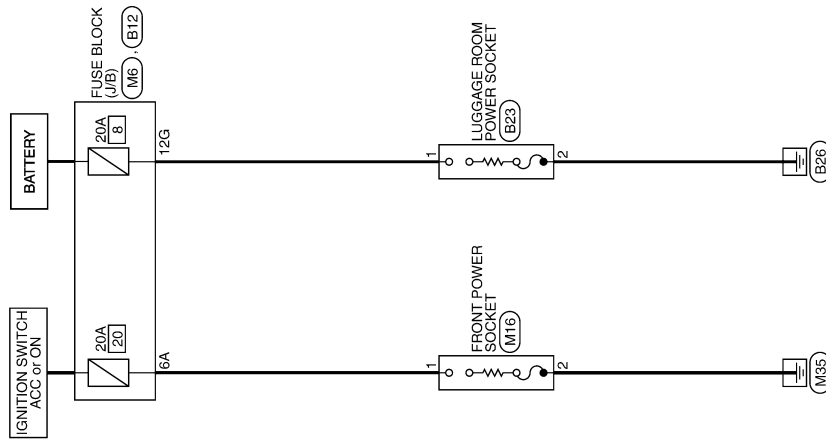

POWER SOCKET

2014/07/25

JRMWG3276GB

POWER SOCKET

< WIRING DIAGRAM >

[POWER SOCKET]

A
B
C
D
E
F
G
H
I
J
K
L
N
O
P

POWER SOCKET

Connector No.	B22
Connector Name	FUSE BLOCK (J/B)
Connector Type	MS2750R-GS



Terminal No.	Color Of Wire	Signal Name [Specification]
1G	Y	-
2G	V	-
3G	P	-
4G	W	-
5G	W	-

Connector No.	B23
Connector Name	LUGGAGE ROOM POWER SOCKET
Connector Type	PR2FEB-Z



Terminal No.	Color Of Wire	Signal Name [Specification]
1	V	-
2	B	-

Connector No.	M6
Connector Name	FUSE BLOCK (J/B)
Connector Type	CS36FW-M2



Terminal No.	Color Of Wire	Signal Name [Specification]
1A	P	-
2A	G	-
3A	L	-
4A	GR	-
5A	V	-
6A	R	-
7A	GR	-
8A	L	-

Connector No.	M16
Connector Name	FRONT POWER SOCKET
Connector Type	PR2FEB-Z



Terminal No.	Color Of Wire	Signal Name [Specification]
1	R	-
2	B	-

JRMWG3277GB

PWO

POWER SOCKET

< REMOVAL AND INSTALLATION >

[POWER SOCKET]

REMOVAL AND INSTALLATION

POWER SOCKET

FRONT POWER SOCKET

FRONT POWER SOCKET : Exploded View

INFOID:000000011326175

- 1 : Inner socket
- 2 : Ring

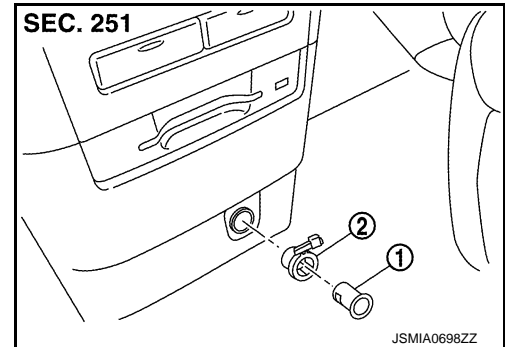

FRONT POWER SOCKET : Removal and Installation

INFOID:000000011326176

REMOVAL

1. Remove instrument lower cover center. Refer to [JP-14. "Removal and Installation"](#).
2. Pull out inner socket (1) by pushing the pawls (B) of the ring (2) from the inner socket hole (square) (A).

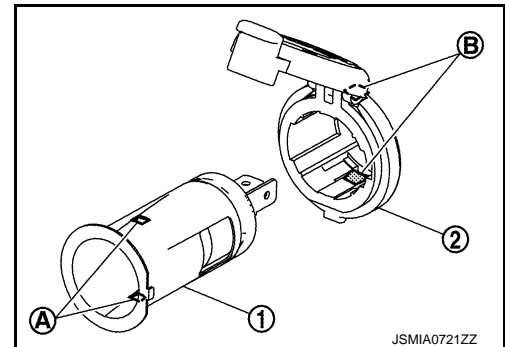

3. Press the ring pawls from the back of the instrument lower cover center to remove the ring.

 : Pawl

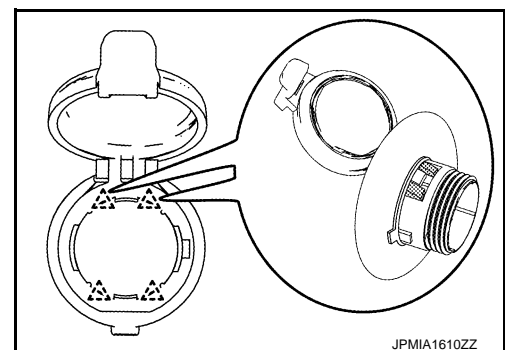

INSTALLATION

Note the following, and install in the reverse order of removal.

POWER SOCKET

< REMOVAL AND INSTALLATION >

[POWER SOCKET]

Align the cut outs of inner socket, ring and instrument lower cover center.

A : Cut out

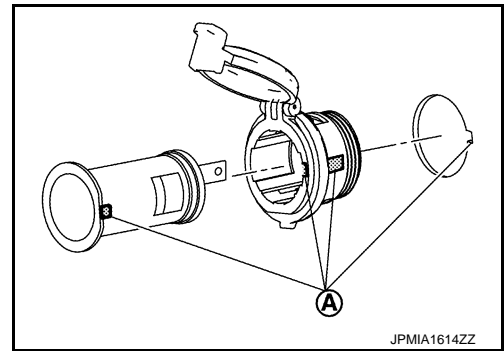

LUGGAGE ROOM POWER SOCKET

LUGGAGE ROOM POWER SOCKET : Exploded View

INFOID:0000000011326177

1 : Inner socket

2 : Ring

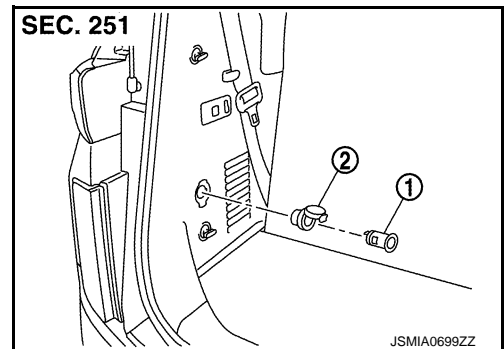

LUGGAGE ROOM POWER SOCKET : Removal and Installation

INFOID:0000000011326178

REMOVAL

1. Remove clips on the rear side of the luggage side lower finisher (LH) to obtain space for work. Refer to [INT-43, "LUGGAGE SIDE LOWER FINISHER : Removal and Installation"](#).
2. Disconnect power socket connector.
3. Pull out inner socket (1) by pushing the pawls (B) of the ring (2) from the inner socket hole (square) (A).

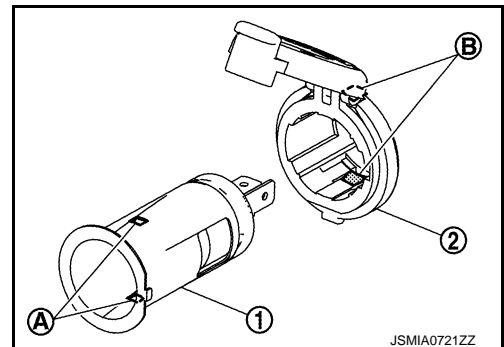

4. Press the ring pawls from the back of the luggage side lower finisher (LH) to remove the ring.

△ : Pawl

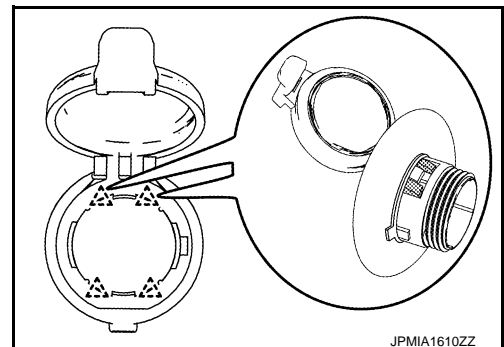

INSTALLATION

A
B
C
D
E
F
G
H
I
J
K
L
PWO
N
O
P

POWER SOCKET

< REMOVAL AND INSTALLATION >

[POWER SOCKET]

Note the following, and install in the reverse order of removal.
Align the cut outs of inner socket, ring and luggage side lower finisher (LH).

A : Cut out

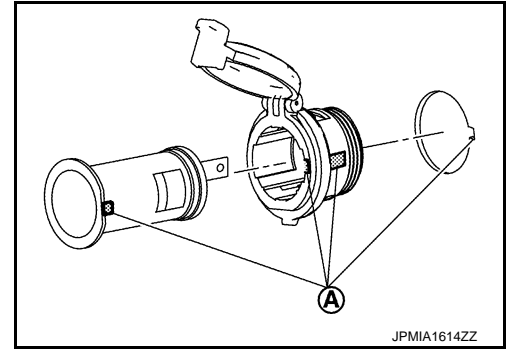

SERVICE DATA AND SPECIFICATIONS (SDS)

< SERVICE DATA AND SPECIFICATIONS (SDS)

[POWER SOCKET]

SERVICE DATA AND SPECIFICATIONS (SDS)

SERVICE DATA AND SPECIFICATIONS (SDS)

Power Socket

INFOID:0000000011326179

Rated voltage	DC 12 V
Maximum electric capacity	120 W or less (Total)
Maximum current	10 A or less (Total)

A
B
C
D
E
F
G
H
I
J
K
L

PWO

N
O
P

PRECAUTION

PRECAUTIONS

Precaution for Supplemental Restraint System (SRS) "AIR BAG" and "SEAT BELT PRE-TENSIONER"

INFOID:000000011326180

The Supplemental Restraint System such as "AIR BAG" and "SEAT BELT PRE-TENSIONER", used along with a front seat belt, helps to reduce the risk or severity of injury to the driver and front passenger for certain types of collision. This system includes seat belt switch inputs and dual stage front air bag modules. The SRS system uses the seat belt switches to determine the front air bag deployment, and may only deploy one front air bag, depending on the severity of a collision and whether the front occupants are belted or unbelted. Information necessary to service the system safely is included in the "SRS AIR BAG" and "SEAT BELT" of this Service Manual.

WARNING:

Always observe the following items for preventing accidental activation.

- To avoid rendering the SRS inoperative, which could increase the risk of personal injury or death in the event of a collision that would result in air bag inflation, all maintenance must be performed by an authorized NISSAN/INFINITI dealer.
- Improper maintenance, including incorrect removal and installation of the SRS, can lead to personal injury caused by unintentional activation of the system. For removal of Spiral Cable and Air Bag Module, see "SRS AIR BAG".
- Never use electrical test equipment on any circuit related to the SRS unless instructed to in this Service Manual. SRS wiring harnesses can be identified by yellow and/or orange harnesses or harness connectors.

PRECAUTIONS WHEN USING POWER TOOLS (AIR OR ELECTRIC) AND HAMMERS

WARNING:

Always observe the following items for preventing accidental activation.

- When working near the Air Bag Diagnosis Sensor Unit or other Air Bag System sensors with the ignition ON or engine running, never use air or electric power tools or strike near the sensor(s) with a hammer. Heavy vibration could activate the sensor(s) and deploy the air bag(s), possibly causing serious injury.
- When using air or electric power tools or hammers, always switch the ignition OFF, disconnect the battery, and wait at least 3 minutes before performing any service.

Precautions for Removing Battery Terminal

INFOID:000000011326181

- When removing the 12V battery terminal, turn OFF the ignition switch and wait at least 30 seconds.

NOTE:

ECU may be active for several tens of seconds after the ignition switch is turned OFF. If the battery terminal is removed before ECU stops, then a DTC detection error or ECU data corruption may occur.

- For vehicles with the 2-batteries, be sure to connect the main battery and the sub battery before turning ON the ignition switch.

NOTE:

If the ignition switch is turned ON with any one of the terminals of main battery and sub battery disconnected, then DTC may be detected.

- After installing the 12V battery, always check "Self Diagnosis Result" of all ECUs and erase DTC.

NOTE:

The removal of 12V battery may cause a DTC detection error.

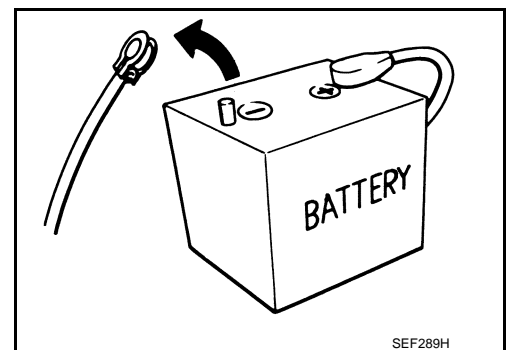

COMPONENT PARTS

< SYSTEM DESCRIPTION >

[AC 120 V OUTLET]

SYSTEM DESCRIPTION

COMPONENT PARTS

Component Parts Location

INFOID:000000011326182

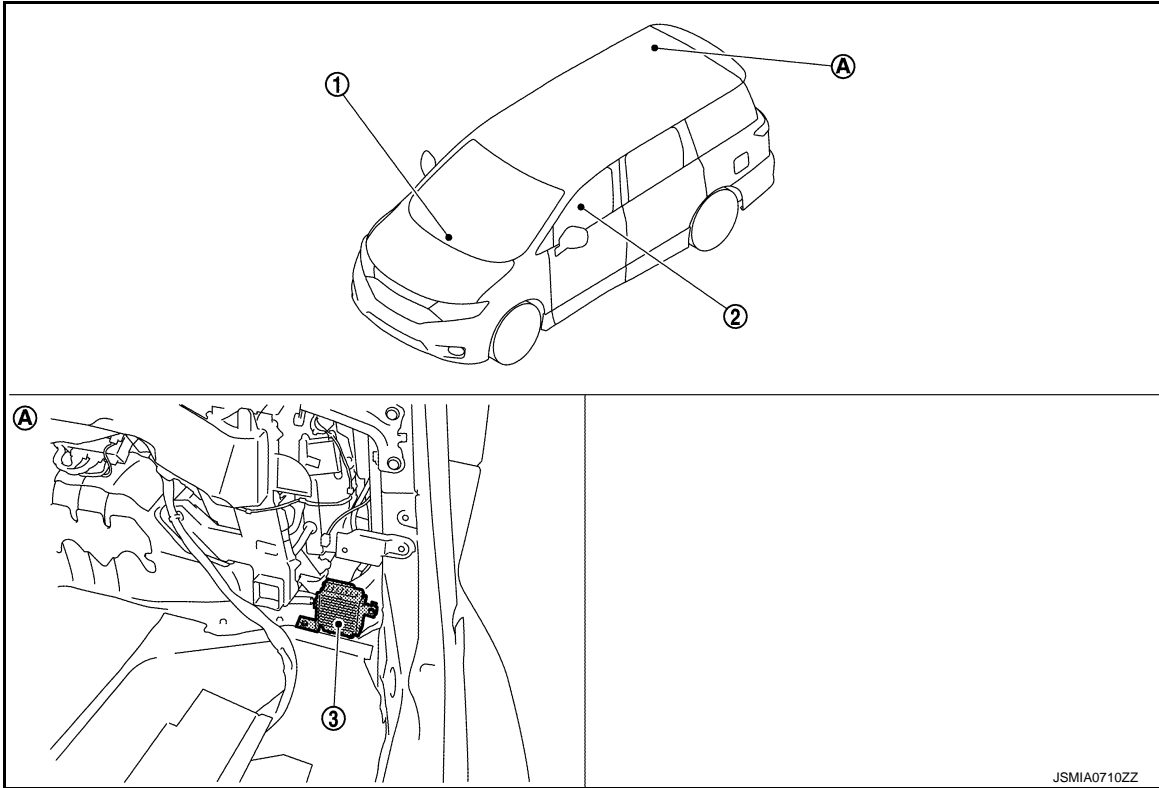

- A. Luggage room finisher RH remove condition

COMPONENT PARTS DESCRIPTION

No.	Component	Function
1.	AC 120 V outlet main switch	PWO-11, "AC 120 V Outlet Main Switch"
2.	AC 120 V outlet	PWO-12, "AC 120 V Outlet"
3.	Inverter unit	PWO-12, "Inverter Unit"

PWO

AC 120 V Outlet Main Switch

INFOID:000000011326183

The operation of the switch enables the inverter unit to activate/inactivate and turn ON/OFF AC 120 V output.

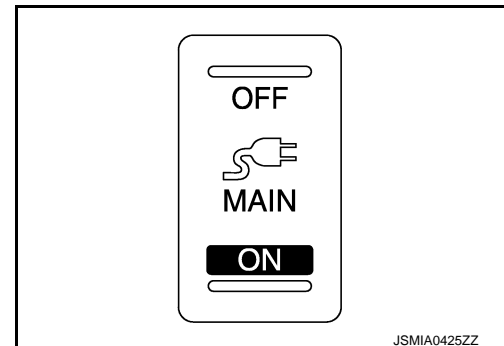

JSMIA0425ZZ

COMPONENT PARTS

< SYSTEM DESCRIPTION >

[AC 120 V OUTLET]

AC 120 V Outlet

INFOID:000000011326184

The AC 120 V outlet allows using AC 120 V converted in the inverter unit as an outlet.

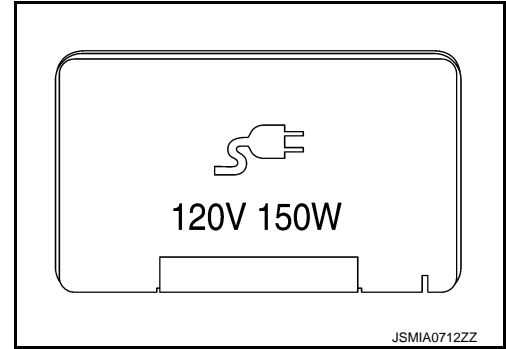

Inverter Unit

INFOID:000000011326185

The inverter unit converts an applied power supply voltage (approximately DC 12 V) to AC 120 V and outputs the converted voltage.

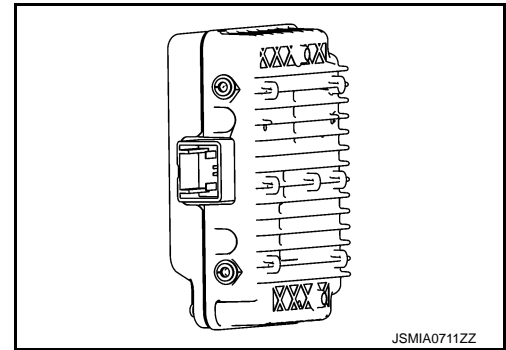

SYSTEM

< SYSTEM DESCRIPTION >

[AC 120 V OUTLET]

SYSTEM

System Description

INFOID:000000011326186

SYSTEM DIAGRAM

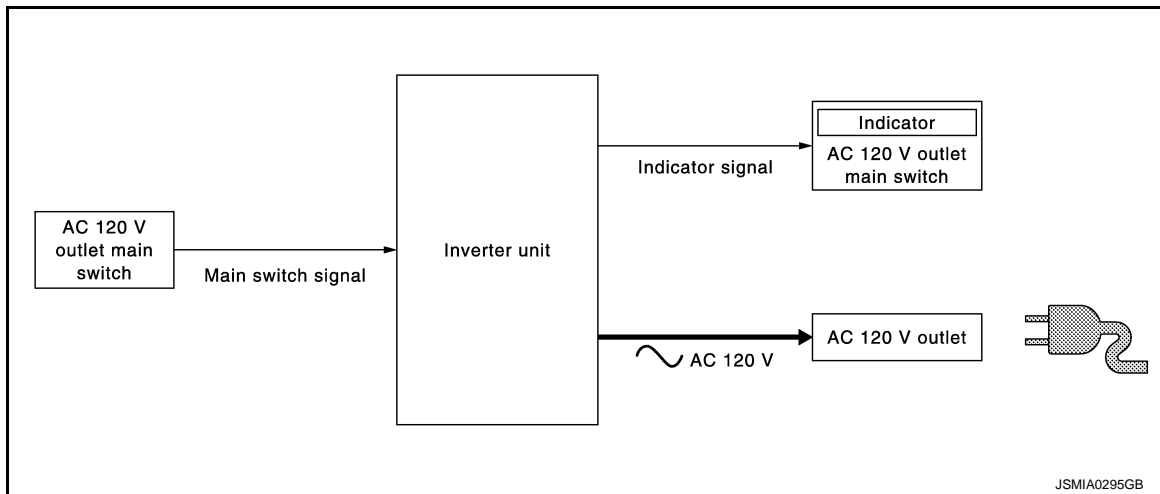

SYSTEM DESCRIPTION

- When turning ON the AC 120 V outlet main switch with the ignition switch ON, the indicator turns ON and the inverter unit is activated.
- The inverter unit converts power supply voltage to AC 120 V and outputs the converted voltage to the AC 120 V outlet two seconds after the AC 120 V outlet main switch is turned ON.

A
B
C
D
E
F
G
H
I
J
K
L

PWO

N
O
P

Circuit Diagram

INFOID:000000011326187

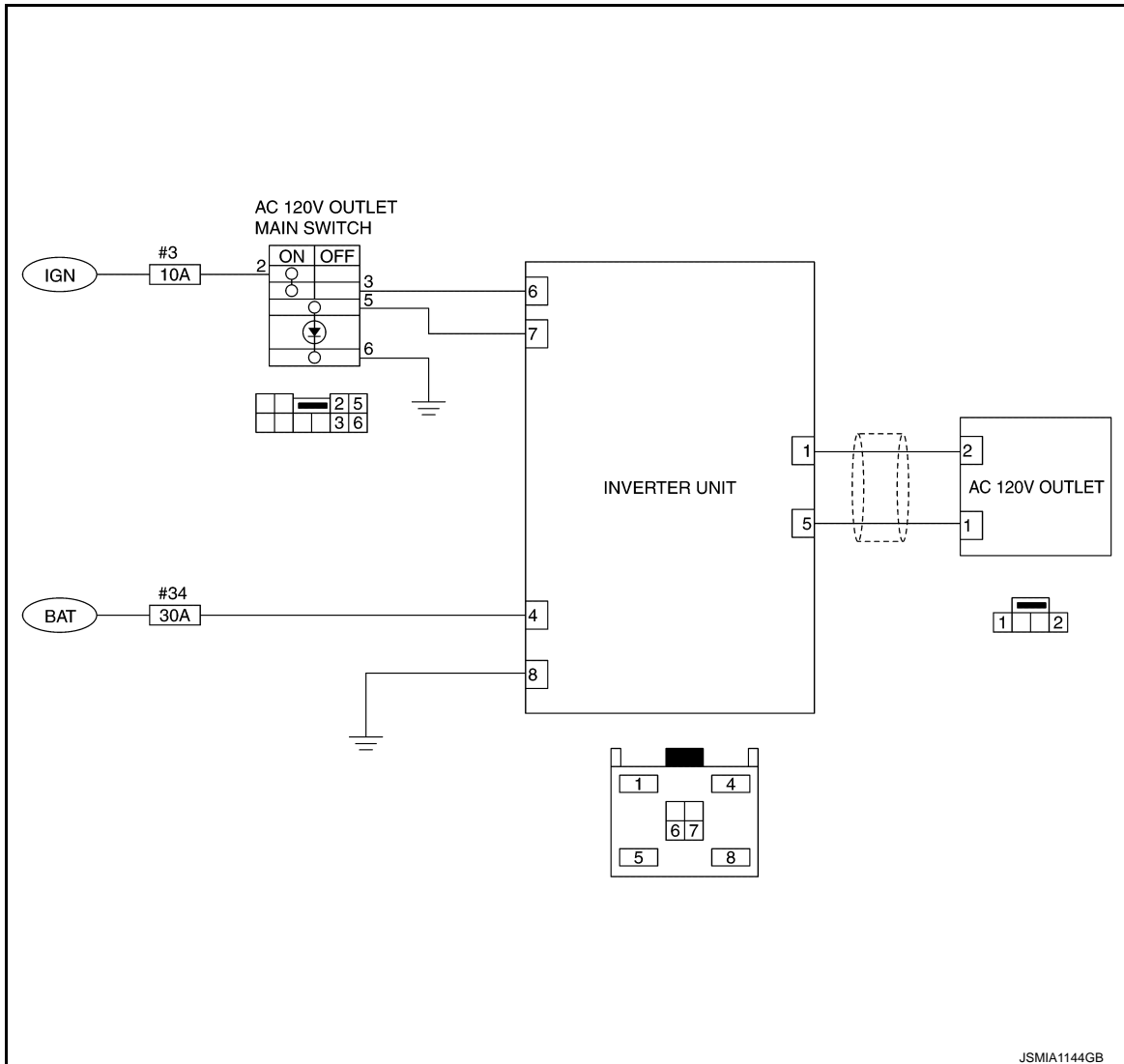

JSMIA1144GB

Fail-safe

INFOID:000000011326188

When a malfunction listed below occurs, the inverter unit turns OFF the AC 120 V outlet main switch indicator and stops the output by operating the fail-safe.

Malfunction item	Fail-safe condition	Fail-safe cancellation condition
Inverter unit is overheated	When the inverter unit is overheated, the output stops to protect the inverter unit.	After the inverter unit temperature is lowered, the AC 120 V outlet main switch ON ⇒ OFF ⇒ ON operation allows normal return.
Inverter unit power supply voltage is 11.5 V or less	When inverter unit input voltage is lowered, the output stops to protect the battery from running out.	Automatic normal return when inverter unit power supply voltage reaches 11.5 V - 16 V.
Inverter unit power supply voltage is 16 V - 18 V	When inverter unit input voltage reaches 16 V - 18 V, the output stops to protect the inverter unit.	Automatic normal return when inverter unit power supply voltage reaches 11.5 V - 16 V.
Inverter unit power supply voltage is 18 V or more	When inverter unit input voltage reaches 18 V or more, the output stops to protect the inverter unit.	After the inverter unit power supply voltage reaches 11.5 V - 16 V, the AC 120V outlet main switch ON ⇒ OFF ⇒ ON operation allows normal return.

SYSTEM

< SYSTEM DESCRIPTION >

[AC 120 V OUTLET]

Malfunction item	Fail-safe condition	Fail-safe cancellation condition
Inverter unit output current is 2.8 A or more	When inverter unit output current reaches 2.8 A or more, the output stops to prevent over current. (e.g. connecting an electric appliance exceeding rated output)	Automatic normal return when inverter output current reaches 2.8 A.
Inverter unit output signal (AC 120 V output signal) is shorted	When inverter unit output signal is shorted, the output stops.	After recovering from inverter unit output signal short, the AC 120 V outlet main switch ON ⇒ OFF ⇒ ON operation allows normal return.

A

B

C

D

E

F

G

H

I

J

K

L

PWO

N

O

P

INVERTER UNIT

< ECU DIAGNOSIS INFORMATION >

[AC 120 V OUTLET]

ECU DIAGNOSIS INFORMATION

INVERTER UNIT

Reference Value

INFOID:000000011326189

TERMINAL LAYOUT

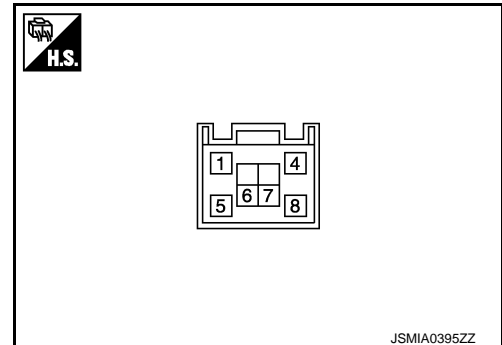

PHYSICAL VALUES

Terminal No. (Wire color)		Description		Condition	Standard value	Value (Approx.)
+	-	Signal name	Input/ Output			
1 (Y)	5 (L)	AC 120 V output	Output	Ignition switch OFF	—	0 V
				When AC 120 V outlet main switch ON (When using circuit tester)	108 – 132 V	AC 120 V
				When AC 120 V outlet main switch ON (When using oscilloscope)		<p>Reference value</p>
4 (W)	Ground	Battery power supply	Input	Ignition switch OFF	11.5 – 16 V	Battery power supply
5 (L)	1 (Y)	AC 120 V output	Output	Ignition switch OFF	—	0 V
				When AC 120 V outlet main switch ON (When using circuit tester)	108 – 132 V	AC 120 V
				When AC 120 V outlet main switch ON (When using oscilloscope)		<p>Reference value</p>

INVERTER UNIT

< ECU DIAGNOSIS INFORMATION >

[AC 120 V OUTLET]

Terminal No. (Wire color)		Description		Condition	Standard value	Value (Approx.)	
+	-	Signal name	Input/ Output				
6 (P)		AC 120 V outlet main switch	Input	Ignition switch ON	When AC 120 V outlet main switch OFF	—	0 V
					When AC 120 V outlet main switch ON	—	12 V
7 (BR)	Grou nd	AC 120 V outlet main switch indi- cator	Output	Ignition switch ON	When AC 120 V outlet main switch OFF	—	0 V
					When AC 120 V outlet main switch ON	—	5.2 V
8 (B)		Ground	—	Ignition switch ON		—	0 V

CAUTION:

- To measure AC 120 V output signal, always use the circuit tester or oscilloscope AC range.
- Never allow the probes to contact each other.
- Because of modified sine wave output of the AC 120 V output signal, voltage cannot be measured accurately without using a circuit tester that can measure true RMS (root mean square).

Fail-safe

INFOID:0000000011326190

When a malfunction listed below occurs, the inverter unit turns OFF the AC 120 V outlet main switch indicator and stops the output by operating the fail-safe.

Malfunction item	Fail-safe condition	Fail-safe cancellation condition
Inverter unit is overheat- ed	When the inverter unit is overheated, the output stops to protect the inverter unit.	After the inverter unit temperature is lowered, the AC 120 V outlet main switch ON ⇒ OFF ⇒ ON operation allows normal return.
Inverter unit power supply voltage is 11.5 V or less	When inverter unit input voltage is lowered, the output stops to protect the battery from running out.	Automatic normal return when inverter unit power supply voltage reaches 11.5 V - 16 V.
Inverter unit power supply voltage is 16 V - 18 V	When inverter unit input voltage reaches 16 V - 18 V, the output stops to protect the inverter unit.	Automatic normal return when inverter unit power supply voltage reaches 11.5 V - 16 V.
Inverter unit power supply voltage is 18 V or more	When inverter unit input voltage reaches 18 V or more, the output stops to protect the inverter unit.	After the inverter unit power supply voltage reaches 11.5 V - 16 V, the AC 120V outlet main switch ON ⇒ OFF ⇒ ON operation allows normal return.
Inverter unit output current is 2.8 A or more	When inverter unit output current reaches 2.8 A or more, the output stops to prevent over current. (e.g. connecting an electric appliance exceeding rated output)	Automatic normal return when inverter output current reaches 2.8 A.
Inverter unit output signal (AC 120 V output signal) is shorted	When inverter unit output signal is shorted, the output stops.	After recovering from inverter unit output signal short, the AC 120 V outlet main switch ON ⇒ OFF ⇒ ON operation allows normal return.

PWO

AC 120 V POWER OUTLET

< WIRING DIAGRAM >

[AC 120 V OUTLET]

WIRING DIAGRAM

AC 120 V POWER OUTLET

Wiring Diagram

INFOID:0000000011326191

AC 120 V POWER OUTLET

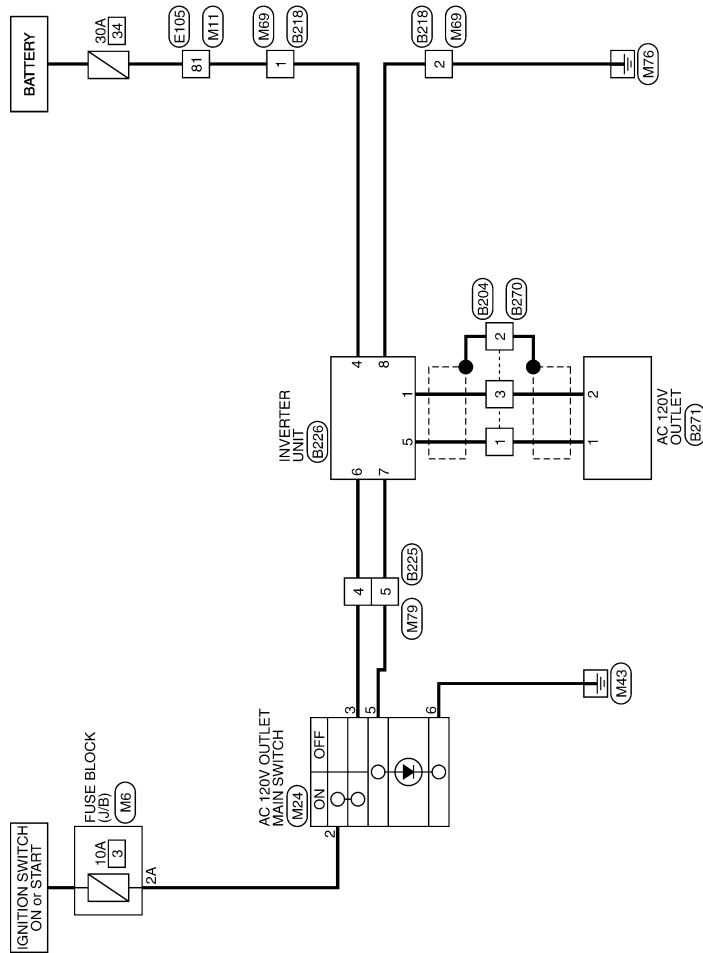

2014/07/25

JRMWG3278GB

AC 120 V POWER OUTLET

< WIRING DIAGRAM >

[AC 120 V OUTLET]

AC 120 V POWER OUTLET

Connector No.	B204
Connector Name	WIRE TO WIRE
Connector Type	NSDMMH-CS



Terminal No.	Color Of Wire	Signal Name [Specification]
1	R	-
3	P	-

Connector No.	B218
Connector Name	WIRE TO WIRE
Connector Type	MO2MM-GY-LC



Terminal No.	Color Of Wire	Signal Name [Specification]
1	W	-
2	B	-

Connector No.	B225
Connector Name	WIRE TO WIRE
Connector Type	TH18MM-NH

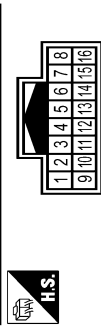

Terminal No.	Color Of Wire	Signal Name [Specification]
2	W	-
3	B	-
4	P	-
5	G	-
9	L	-
10	P	-
11	SB	-
12	GR	-
13	R	-
14	G	-
15	L	-
16	Y	-

Connector No.	B226
Connector Name	INVERTER UNIT
Connector Type	AA-EG4FB-24UG4

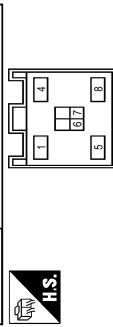

Terminal No.	Color Of Wire	Signal Name [Specification]
1	P	AC 120 V OUTPUT
4	W	BAT
5	R	AC 120 V OUTPUT
6	P	MAIN SW SIGNAL
7	G	MAIN SW INDICATOR
8	B	GROUND

Connector No.	B270
Connector Name	WIRE TO WIRE
Connector Type	NSD4FW-CS

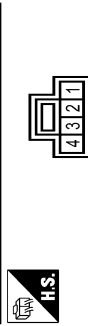

Terminal No.	Color Of Wire	Signal Name [Specification]
1	BR	-
2	SHIELD	-
3	Y	-

Connector No.	B271
Connector Name	AC 120V OUTLET
Connector Type	NSD4FW-CS

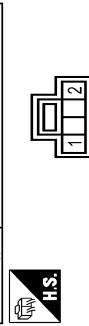

Terminal No.	Color Of Wire	Signal Name [Specification]
1	BR	-
2	Y	-

Connector No.	E105
Connector Name	WIRE TO WIRE
Connector Type	TH70MM-CS10-48

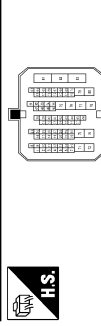

Terminal No.	Color Of Wire	Signal Name [Specification]
1	SHIELD	-
2	W	-
3	B	-
4	R	-
6	LG	-
7	GR	-
8	GR	-
9	V	-
10	BR	-
11	Y	-
12	O	-
13	W	-
14	L	-
15	P	-
31	GR	-
32	V	-
37	BR	-
38	G	-
39	V	-
40	P	-
41	L	-
42	LG	-
43	O	-
45	P	-
46	SB	-
47	V	-
49	L	-
51	BR	-
52	G	-
53	B	-
54	O	-
55	Y	-
56	SHIELD	-
61	P	-
62	G	-

A
B
C
D
E
F
G
H
I
J
K
L
N
O
P

PWO

JRMWG3279GB

AC 120 V POWER OUTLET

< WIRING DIAGRAM >

[AC 120 V OUTLET]

AC 120 V POWER OUTLET

Terminal No.	Color Of Wire	Signal Name [Specification]
83	W/L	-
84	W/R	-
85	W	-
86	Y	-
87	R	-
88	R	-
89	R	-
90	R	-
91	R	-
92	L	-
93	GR	-
94	Y	-
95	SB	-
96	Y	-
97	G	-
98	O	-
99	R	-
100	L	-
101	LG	-
102	R	-

Connector No.	M6
Connector Name	FUSE BLOCK (J/B)
Connector Type	CSD6FY-M2

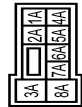

Terminal No.	Color Of Wire	Signal Name [Specification]
1A	Y	-
2A	G	-
3A	L	-
4A	GR	-
5A	V	-
6A	R	-
7A	GR	-
8A	L	-

Connector No.	M11
Connector Name	WIRE TO WIRE
Connector Type	TH7DFW-CS19-M8



Terminal No.	Color Of Wire	Signal Name [Specification]
1	SHIELD	-
2	W	-
3	B	-
4	R	-
6	G	-
7	R	-
8	G	-
9	B	-
10	R	-
11	W	-
12	LG	- [Without automatic drive positioner]
13	G	- [With automatic drive positioner]
14	Y	- [Without automatic drive positioner]
15	Y	- [With automatic drive positioner]
16	B	-
17	R	-
18	R	-
19	LG	-
20	BR	- [With automatic drive positioner]
21	R	- [Without automatic drive positioner]
22	BE	- [Without automatic drive positioner]
23	Y	- [With automatic drive positioner]
24	P	-
41	L	-
42	G	-
43	W	-
44	P	-
45	V	-
46	V	-
47	R	-
48	G	-
51	G	-
52	W	-
53	B	-
54	LG	-
55	L	-

Terminal No.	Color Of Wire	Signal Name [Specification]
56	SHIELD	-
61	R	-
62	R	-
63	B	-
64	W	-
66	W	-
67	BR	-
69	P	-
71	R	-
72	L	-
73	LG	-
74	Y	-
75	Y	-
76	V	-
77	P	-
78	BR	-
80	Y	-
81	W	-
82	L	-
83	R	-

Connector No.	M24
Connector Name	AC 120V OUTLET MAIN SWITCH
Connector Type	TK10FW

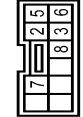

Terminal No.	Color Of Wire	Signal Name [Specification]
2	G	-
3	P	-
5	BR	-
6	B	-
7	P	-
8	B	-

Connector No.	M69
Connector Name	WIRE TO WIRE
Connector Type	M02FW-GY-LC



Terminal No.	Color Of Wire	Signal Name [Specification]
1	W	-
2	B	-

Connector No.	M79
Connector Name	WIRE TO WIRE
Connector Type	TH16FW-NH



Terminal No.	Color Of Wire	Signal Name [Specification]
2	GR	-
3	B	-
4	P	-
5	BR	-
9	L	-
10	P	-
11	W	-
12	R	-
13	BE	-
14	W	-
15	G	-
16	P	-

DIAGNOSIS AND REPAIR WORK FLOW

< BASIC INSPECTION >

[AC 120 V OUTLET]

BASIC INSPECTION

DIAGNOSIS AND REPAIR WORK FLOW

Work Flow

INFOID:000000011326192

OVERALL SEQUENCE

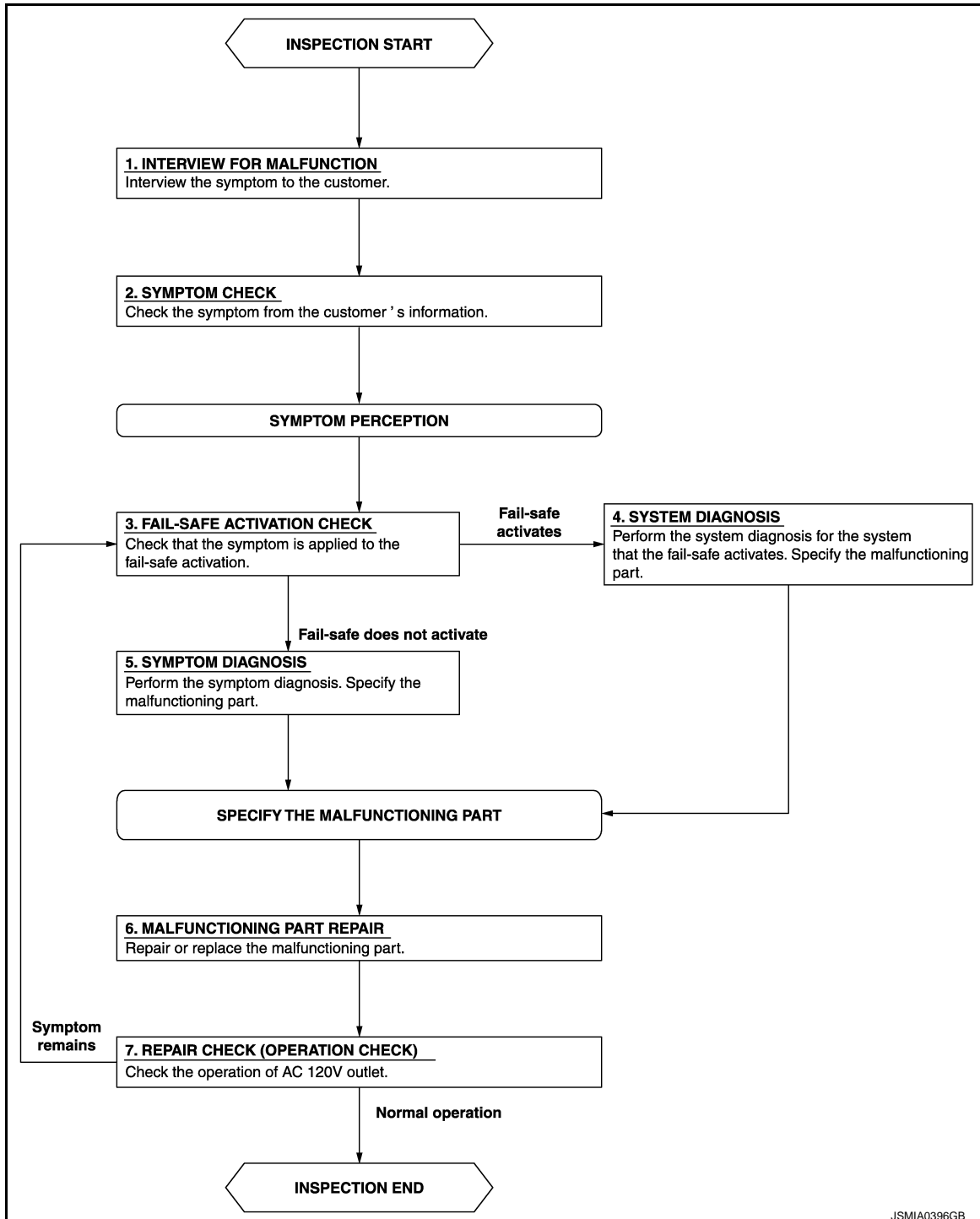

DETAILED FLOW

1. INTERVIEW FOR MALFUNCTION

Interview the symptom to the customer.

DIAGNOSIS AND REPAIR WORK FLOW

< BASIC INSPECTION >

[AC 120 V OUTLET]

>> GO TO 2.

2. SYMPTOM CHECK

Check the symptom from the customer's information.

>> GO TO 3.

3. FAIL-SAFE ACTIVATION CHECK

Check that the symptom is applied to the fail-safe activation.

Does the fail-safe activate?

YES >> GO TO 4.

NO >> GO TO 5.

4. SYSTEM DIAGNOSIS

Perform the system diagnosis for the system that the fail-safe activates. Specify the malfunctioning part.

>> GO TO 6.

5. SYMPTOM DIAGNOSIS

Perform the symptom diagnosis. Specify the malfunctioning part.

>> GO TO 6.

6. MALFUNCTIONING PART REPAIR

Repair or replace the malfunctioning part.

>> GO TO 7.

7. REPAIR CHECK (OPERATION CHECK)

Check the operation of AC 120 V outlet.

Does it operate normally?

YES >> INSPECTION END

NO >> GO TO 3.

POWER SUPPLY AND GROUND CIRCUIT

< DTC/CIRCUIT DIAGNOSIS >

[AC 120 V OUTLET]

DTC/CIRCUIT DIAGNOSIS

POWER SUPPLY AND GROUND CIRCUIT

Diagnosis Procedure

INFOID:000000011326193

1. CHECK FUSE

Check that the following fuse is not blown.

Signal name	Fuse No.
Battery power supply	34

Is the fuse fusing?

YES >> Replace the blown fuse after repairing the affected circuit if a fuse is blown.

NO >> GO TO 2.

2. CHECK INVERTER UNIT POWER SUPPLY CIRCUIT

Check voltage between inverter unit harness connector and ground.

Terminal		Condition	Standard value	Voltage (Approx.)
(+)	(-)			
Inverter unit		Ignition switch	11.5 – 16 V	Battery voltage
Connector	Terminal			
B226	4			
		OFF		

Is the inspection result normal?

YES >> GO TO 3.

NO >> Repair or replace the inverter unit power supply circuit.

3. CHECK INVERTER UNIT GROUND CIRCUIT

1. Turn the ignition switch OFF.
2. Disconnect the inverter unit connector.
3. Check for continuity between inverter unit harness connector and ground.

Inverter unit		Ground	Continuity
Connector	Terminal		
B226	8		Existed

Is the inspection result normal?

YES >> INSPECTION END

NO >> Repair or replace the inverter unit ground circuit.

A
B
C
D
E
F
G
H
I
J
K
L
N
O
P

PWO

AC 120 V OUTLET MAIN SWITCH POWER SUPPLY CIRCUIT

< DTC/CIRCUIT DIAGNOSIS >

[AC 120 V OUTLET]

AC 120 V OUTLET MAIN SWITCH POWER SUPPLY CIRCUIT

Diagnosis Procedure

INFOID:000000011326194

1. CHECK FUSE

Check that the following fuse is not blown.

Signal name	Fuse No.
Ignition power supply	3

Is the fuse fusing?

YES >> Replace the blown fuse after repairing the affected circuit if a fuse is blown.

NO >> GO TO 2.

2. CHECK POWER SUPPLY FOR AC 120 V OUTLET MAIN SWITCH

1. Turn ignition switch ON.
2. Check for voltage between the AC 120 V main switch harness connector and ground.

Terminals		Condition	Voltage (Approx.)
(+)	(-)		
AC 120 V outlet main switch		Ignition switch	0 V
Connector	Terminal		
M24	2	OFF	
		ON	Battery voltage

Is the inspection result normal?

YES >> INSPECTION END

NO >> Repair the AC 120 V main switch power supply circuit.

AC 120 V OUTLET MAIN SWITCH INPUT SIGNAL CIRCUIT

< DTC/CIRCUIT DIAGNOSIS >

[AC 120 V OUTLET]

AC 120 V OUTLET MAIN SWITCH INPUT SIGNAL CIRCUIT

Diagnosis Procedure

INFOID:000000011326195

1. CHECK HARNESS BETWEEN INVERTER UNIT AND AC 120 V OUTLET MAIN SWITCH

1. Turn ignition switch OFF.
2. Disconnect inverter unit connector and AC 120 V outlet main switch connector.
3. Check for continuity between the inverter unit harness connector and AC 120 V outlet main switch harness connector.

Inverter unit		AC 120 V outlet main switch		Continuity
Connector	Terminal	Connector	Terminal	
B226	6	M24	3	Existed

4. Check for continuity between inverter unit harness connector and ground.

Inverter unit		Ground	Continuity
Connector	Terminal		
B226	6		Not existed

Is the inspection result normal?

- YES >> GO TO 2.
NO >> Repair the harnesses or connectors.

2. CHECK AC 120 V OUTLET MAIN SWITCH INPUT SIGNAL

1. Connect inverter unit connector and AC 120 V outlet main switch connector.
2. Turn ignition switch ON.
3. AC 120 V outlet main switch ON.
4. Check for voltage between the inverter unit harness connector and ground.

Terminals		Condition	Voltage (Approx.)
(+)	(-)		
Inverter unit		AC 120 V outlet main switch	0 V
Connector	Terminal		
B226	6		
		ON	Battery voltage

Is the inspection result normal?

- YES >> INSPECTION END
NO >> GO TO 3.

3. CHECK AC 120 V OUTLET MAIN SWITCH

1. Turn ignition switch OFF.
2. Remove AC 120 V outlet main switch.
3. Check AC 120 V outlet main switch. Refer to [PWO-25. "Component Inspection"](#).

Is the inspection result normal?

- YES >> INSPECTION END
NO >> Replace AC 120 V outlet main switch.

Component Inspection

INFOID:000000011326196

1. CHECK AC 120 V OUTLET MAIN SWITCH

Check continuity of AC 120 V outlet main switch.

A
B
C
D
E
F
G
H
I
J
K
L
N
O
P

PWO

AC 120 V OUTLET MAIN SWITCH INPUT SIGNAL CIRCUIT

< DTC/CIRCUIT DIAGNOSIS >

[AC 120 V OUTLET]

Terminal		Condition	Continuity
1	3	When AC 120 V outlet main switch is ON	Existed
		When AC 120 V outlet main switch is OFF	Not existed

Is the inspection result normal?

YES >> INSPECTION END

NO >> Replace AC 120 V outlet main switch.

AC 120 V POWER OUTPUT CIRCUIT

< DTC/CIRCUIT DIAGNOSIS >

[AC 120 V OUTLET]

AC 120 V POWER OUTPUT CIRCUIT

Diagnosis Procedure

INFOID:0000000011326197

1. CHECK HARNESS BETWEEN INVERTER UNIT AND AC 120 V OUTLET

1. Turn ignition switch OFF.
2. Disconnect inverter unit connector and AC 120 V outlet connector.
3. Check for continuity between the inverter unit harness connector and AC 120 V outlet harness connector.

Inverter unit		AC 120 V outlet		Continuity
Connector	Terminal	Connector	Terminal	
B226	5	B271	1	Existed
	1		2	

4. Check for continuity between inverter unit harness connector and ground.

Inverter unit		Ground	Continuity
Connector	Terminal		
B226	5		Not existed
	1		

5. Check for continuity between inverter unit harness connector.

Inverter unit			Continuity
Connector	Terminal		
B226	5	1	Not existed
	1		

Is the inspection result normal?

- YES >> GO TO 2.
 NO >> Repair or replace the harnesses or connectors.

2. CHECK INVERTER UNIT OUTPUT SIGNAL

1. Connect inverter unit connector and AC 120 V outlet connector.
2. Turn ignition switch ON.
3. AC 120 V outlet main switch ON. (AC 120 V outlet main switch indicator ON)
4. Check voltage between inverter unit harness connector.

Terminals				Condition	Standard value	Voltage (Approx.)
(+)		(-)				
Inverter unit		Inverter unit		AC 120 V outlet main switch		
Connector	Terminal	Connector	Terminal			
B226	5	B226	1	OFF	Approx. 0 V	0 V
				ON	AC 108 – 132 V	AC 120 V

CAUTION:

- To measure AC 120 V output signal, always use the circuit tester AC range.
- Never allow the probes to contact each other.

Is the inspection result normal?

- YES >> GO TO 3
 NO >> Replace inverter unit.

3. CHECK AC 120 V OUTLET VOLTAGE

1. AC 120 V outlet main switch ON. (AC 120 V outlet main switch indicator ON)
2. Check voltage between AC 120 V outlet.

PWO

A
B
C
D
E
F
G
H
I
J
K
L
N
O
P

AC 120 V POWER OUTPUT CIRCUIT

< DTC/CIRCUIT DIAGNOSIS >

[AC 120 V OUTLET]

Terminals		Condition	Standard value	Voltage (Approx.)
(+)	(-)			
AC 120 V outlet		AC 120 V outlet main switch		
Terminal				
1	2	OFF	Approx. 0 V	0 V
		ON	AC 108 – 132 V	AC 120 V

CAUTION:

- To measure AC 120 V output signal, always use the circuit tester AC range.
- Never allow the probes to contact each other.

Is the inspection result normal?

- YES >> INSPECTION END
NO >> Replace AC 120 V outlet.

AC 120 V OUTLET MAIN SWITCH INDICATOR CIRCUIT

< DTC/CIRCUIT DIAGNOSIS >

[AC 120 V OUTLET]

AC 120 V OUTLET MAIN SWITCH INDICATOR CIRCUIT

Diagnosis Procedure

INFOID:0000000011326198

1. CHECK HARNESS BETWEEN INVERTER UNIT AND AC 120 V OUTLET MAIN SWITCH

1. Turn ignition switch OFF.
2. Disconnect inverter unit connector and AC 120 V outlet main switch connector.
3. Check continuity between inverter unit harness connector and AC 120 V main switch harness connector.

Inverter unit		AC 120 V outlet main switch		Continuity
Connector	Terminal	Connector	Terminal	
B226	7	M24	5	Existed

4. Check continuity between inverter unit harness connector and ground.

Inverter unit		Ground	Continuity
Connector	Terminal		
B226	7		Not existed

Is the inspection result normal?

- YES >> GO TO 2.
NO >> Repair the harnesses or connectors.

2. CHECK AC 120 V OUTLET MAIN SWITCH GROUND CIRCUIT

Check continuity between AC 120 V outlet main switch harness connector and ground.

AC 120 V outlet main switch		Ground	Continuity
Connector	Terminal		
M24	6		Existed

Is the inspection result normal?

- YES >> GO TO 3.
NO >> Repair the harnesses or connectors.

3. CHECK AC 120 V OUTLET MAIN SWITCH INDICATOR OUTPUT SIGNAL

1. Connect AC 120 V outlet main switch connector and inverter unit connector.
2. Turn ignition switch ON.
3. AC 120 V outlet main switch ON. (AC 120 V output is normal)
4. Check for voltage between the inverter unit harness connector and ground.

Terminals		Condition	Voltage (Approx.)
(+)	(-)		
Inverter unit		AC 120 V outlet main switch	
Connector	Terminal		
B226	7		
		OFF	0 V
		ON	5.2 V

Is the inspection result normal?

- YES >> GO TO 4.
NO >> Replace inverter unit.

4. CHECK AC 120 V OUTLET MAIN SWITCH INDICATOR

1. AC 120 V outlet main switch ON. (AC 120 V output is normal)
2. Check that AC 120 V outlet main switch indicator is illuminated.

Is the inspection result normal?

A
B
C
D
E
F
G
H
I
J
K
L
N
O
P

PWO

AC 120 V OUTLET MAIN SWITCH INDICATOR CIRCUIT

< DTC/CIRCUIT DIAGNOSIS >

[AC 120 V OUTLET]

YES >> INSPECTION END
NO >> Replace AC 120 V outlet main switch.

NO OUTPUT FROM AC 120 V OUTLET

< SYMPTOM DIAGNOSIS >

[AC 120 V OUTLET]

SYMPTOM DIAGNOSIS

NO OUTPUT FROM AC 120 V OUTLET

Diagnosis Procedure

INFOID:000000011326199

1. CHECK FAIL-SAFE ACTIVATION

Check if the symptom is caused by a fail-safe operation. Refer to [PWO-17, "Fail-safe"](#).

Is fail-safe operating?

YES >> Repair the part causing fail-safe operation.

NO >> GO TO 2.

2. CHECK INVERTER UNIT POWER SUPPLY CIRCUIT

Check inverter unit power supply circuit. Refer to [PWO-23, "Diagnosis Procedure"](#).

Is the inspection result normal?

YES >> GO TO 3.

NO >> Repair or replace the malfunctioning parts.

3. CHECK AC 120 V OUTLET MAIN SWITCH POWER SUPPLY CIRCUIT

Check AC 120 V outlet main switch power supply circuit. Refer to [PWO-24, "Diagnosis Procedure"](#).

Is the inspection result normal?

YES >> GO TO 4.

NO >> Repair or replace the malfunctioning parts.

4. CHECK AC 120 V OUTLET MAIN SWITCH INPUT SIGNAL CIRCUIT

Check AC 120 V outlet main switch input signal circuit. Refer to [PWO-25, "Diagnosis Procedure"](#).

Is the inspection result normal?

YES >> GO TO 5.

NO >> Repair or replace the malfunctioning parts.

5. CHECK INVERTER UNIT POWER OUTPUT CIRCUIT

Check inverter unit power output circuit. Refer to [PWO-27, "Diagnosis Procedure"](#).

Is the inspection result normal?

YES >> Refer to [GI-42, "Intermittent Incident"](#).

NO >> Repair or replace the malfunctioning parts.

A
B
C
D
E
F
G
H
I
J
K
L
N
O
P

PWO

AC 120 V OUTLET MAIN SWITCH INDICATOR DOES NOT TURN ON

< SYMPTOM DIAGNOSIS >

[AC 120 V OUTLET]

AC 120 V OUTLET MAIN SWITCH INDICATOR DOES NOT TURN ON

Diagnosis Procedure

INFOID:000000011326200

1. CHECK FAIL-SAFE ACTIVATION

Check if the symptom is caused by a fail-safe operation. Refer to [PWO-17, "Fail-safe"](#).

Is fail-safe operating?

- YES >> Repair the part causing fail-safe operation.
- NO >> GO TO 2.

2. CHECK INVERTER UNIT POWER SUPPLY CIRCUIT

Check inverter unit power supply circuit. Refer to [PWO-23, "Diagnosis Procedure"](#).

Is the inspection result normal?

- YES >> GO TO 3.
- NO >> Repair or replace the malfunctioning parts.

3. CHECK AC 120 V OUTLET MAIN SWITCH POWER SUPPLY CIRCUIT

Check AC 120 V outlet main switch power supply circuit. Refer to [PWO-24, "Diagnosis Procedure"](#).

Is the inspection result normal?

- YES >> GO TO 4.
- NO >> Repair or replace the malfunctioning parts.

4. CHECK AC 120 V OUTLET MAIN SWITCH INPUT SIGNAL CIRCUIT

Check AC 120 V outlet main switch input signal circuit. Refer to [PWO-25, "Diagnosis Procedure"](#).

Is the inspection result normal?

- YES >> GO TO 5.
- NO >> Repair or replace the malfunctioning parts.

5. CHECK AC 120 V OUTLET MAIN SWITCH INDICATOR CIRCUIT

Check AC 120 V outlet main switch indicator circuit. Refer to [PWO-29, "Diagnosis Procedure"](#).

Is the inspection result normal?

- YES >> Refer to [GI-42, "Intermittent Incident"](#).
- NO >> Repair or replace the malfunctioning parts.

NORMAL OPERATING CONDITION

< SYMPTOM DIAGNOSIS >

[AC 120 V OUTLET]

NORMAL OPERATING CONDITION

Description

INFOID:000000011326201

Because of modified sine wave output, the AC 120 V outlet may not operate normally for electric appliance of which electric power consumption is 150 W or less.

- Electric appliances requiring a large amount of electric power consumption at startup (e.g. CRT-based TV, power tool)
- Measuring instruments for data requiring accuracy (e.g. medical equipment, measuring instrument)
- Microprocessor-controlled appliances (e.g. microprocessor-controlled blanket)

Noise may be caused in radio or TV, depending on an electric appliance.

A
B
C
D
E
F
G
H
I
J
K
L

PWO

N
O
P

REMOVAL AND INSTALLATION

INVERTER UNIT

Removal and Installation

INFOID:000000011326202

REMOVAL

1. Remove luggage side lower finisher (RH). Refer to [INT-43. "LUGGAGE SIDE LOWER FINISHER : Removal and Installation"](#).
2. Disconnect inverter unit connector.
3. Remove mounting bolt.
4. Remove inverter unit.

INSTALLATION

Install in the reverse order of removal.

AC 120V OUTLET MAIN SW

< REMOVAL AND INSTALLATION >

[AC 120 V OUTLET]

AC 120V OUTLET MAIN SW

Removal and Installation

INFOID:000000011326203

REMOVAL

1. Remove instrument lower panel center. Refer to [IP-14. "Removal and Installation"](#).
2. Insert remover tool (B) into pawl (A) of instrument lower panel center and press the pawl toward direction (C) to release the pawl.
3. Remove AC 120 V main switch from instrument lower panel center in direction (D).

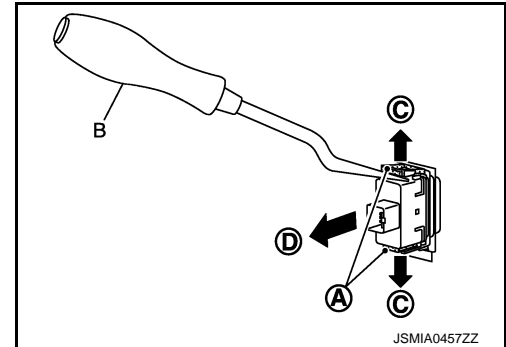

INSTALLATION

Install in the reverse order of removal.

A
B
C
D
E
F
G
H
I
J
K
L

PWO

N
O
P

AC 120 V OUTLET

< REMOVAL AND INSTALLATION >

[AC 120 V OUTLET]

AC 120 V OUTLET

Removal and Installation

INFOID:000000011326204

REMOVAL

1. Remove center console upper finisher. Refer to [IP-28. "Removal and Installation"](#).
2. Press pawl (A) in direction (B) from the back of center console upper finisher to remove AC 120 V outlet in direction (C).

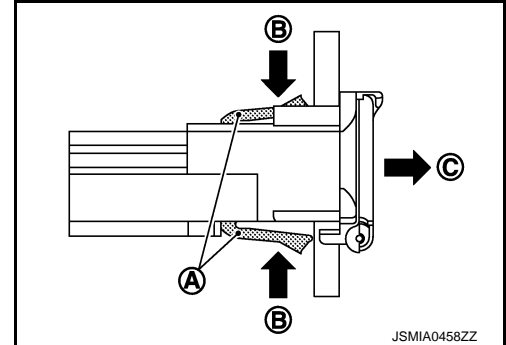

INSTALLATION

Install in the reverse order of removal.

SERVICE DATA AND SPECIFICATIONS (SDS)

< SERVICE DATA AND SPECIFICATIONS (SDS)

[AC 120 V OUTLET]

SERVICE DATA AND SPECIFICATIONS (SDS)

SERVICE DATA AND SPECIFICATIONS (SDS)

AC 120 V Power Outlet

INFOID:0000000011326205

Rated voltage	AC 120 V
Maximum electric capacity	150 W or less (Total)
Maximum current	1.25 A or less (Total)

A

B

C

D

E

F

G

H

I

J

K

L

PWO

N

O

P