

RF
SECTION
ROOF

A
 B
 C
 D
 E
 F
 G
 H
 I
 J
 RF
 L
 M
 N
 O
 P

CONTENTS

<p>PRECAUTION 3</p> <p>PRECAUTIONS 3</p> <p style="padding-left: 20px;">Precaution for Supplemental Restraint System (SRS) "AIR BAG" and "SEAT BELT PRE-TENSIONER"3</p> <p style="padding-left: 20px;">Precaution for Procedure without Cowl Top Cover.....3</p> <p style="padding-left: 20px;">Precautions For Xenon Headlamp Service3</p> <p style="padding-left: 20px;">Precautions for Removing Battery Terminal4</p> <p>PREPARATION 5</p> <p>PREPARATION 5</p> <p style="padding-left: 20px;">Special Service Tool5</p> <p style="padding-left: 20px;">Commercial Service Tool5</p> <p>SYSTEM DESCRIPTION 6</p> <p>COMPONENT PARTS 6</p> <p style="padding-left: 20px;">Component Parts Location6</p> <p style="padding-left: 20px;">Rear Sunroof Motor Assembly7</p> <p style="padding-left: 20px;">Rear Sunroof Switch (Rear)7</p> <p style="padding-left: 20px;">Front Sunroof Motor Assembly7</p> <p style="padding-left: 20px;">Front Sunroof Switch/Rear Sunroof Switch7</p> <p>SYSTEM 8</p> <p style="padding-left: 20px;">System Description8</p> <p style="padding-left: 20px;">Circuit Diagram 11</p> <p>ECU DIAGNOSIS INFORMATION12</p> <p>BCM (BODY CONTROL MODULE)12</p> <p style="padding-left: 20px;">List of ECU Reference 12</p> <p>FRONT SUNROOF MOTOR ASSEMBLY13</p> <p style="padding-left: 20px;">Reference Value 13</p> <p>REAR SUNROOF MOTOR ASSEMBLY14</p> <p style="padding-left: 20px;">Reference Value 14</p> <p>WIRING DIAGRAM15</p> <p>SUNROOF MOTOR ASSEMBLY15</p>	<p style="padding-left: 20px;">Wiring Diagram15</p> <p>BASIC INSPECTION20</p> <p>DIAGNOSIS AND REPAIR WORKFLOW20</p> <p style="padding-left: 20px;">WorkFlow20</p> <p>INSPECTION AND ADJUSTMENT21</p> <p>FRONT SUNROOF21</p> <p style="padding-left: 20px;">FRONT SUNROOF : Description21</p> <p style="padding-left: 20px;">FRONT SUNROOF : Special Repair Requirement21</p> <p>REAR SUNROOF21</p> <p style="padding-left: 20px;">REAR SUNROOF : Description21</p> <p style="padding-left: 20px;">REAR SUNROOF : Special Repair Requirement.....21</p> <p>DTC/CIRCUIT DIAGNOSIS22</p> <p>POWER SUPPLY AND GROUND CIRCUIT22</p> <p>FRONT SUNROOF MOTOR ASSEMBLY22</p> <p style="padding-left: 20px;">FRONT SUNROOF MOTOR ASSEMBLY : Diagnosis Procedure22</p> <p>REAR SUNROOF MOTOR ASSEMBLY22</p> <p style="padding-left: 20px;">REAR SUNROOF MOTOR ASSEMBLY : Diagnosis Procedure22</p> <p>FRONT SUNROOF MOTOR ASSEMBLY24</p> <p style="padding-left: 20px;">Component Function Check24</p> <p style="padding-left: 20px;">Diagnosis Procedure24</p> <p>REAR SUNROOF MOTOR ASSEMBLY26</p> <p style="padding-left: 20px;">Component Function Check26</p> <p style="padding-left: 20px;">Diagnosis Procedure26</p> <p>POWER WINDOW SERIAL LINK28</p> <p style="padding-left: 20px;">Component Function Check28</p> <p style="padding-left: 20px;">Diagnosis Procedure28</p> <p>SUNROOF SWITCH30</p>
--------------------------------------------------------------------------------------------------------------------------------------------------------------------------------------------------------------------------------------------------------------------------------------------------------------------------------------------------------------------------------------------------------------------------------------------------------------------------------------------------------------------------------------------------------------------------------------------------------------------------------------------------------------------------------------------------------------------------------------------------------------------------------------------------------------------------------------------------------------------------------------------------------------------------------------------------------------------------------------------------------------------------------------------------------------------------------------------------------------------------------------------------------------------------------------------------------------------------------------------------------------------------------------------------------------------------------------------------------------------------------------------------------------------------------------------------------------------------------------------------------------------------------------------------------------------------------------------------------------------------------------------------------------------------------------------------------------------------------------------------------------------------	-------------------------------------------------------------------------------------------------------------------------------------------------------------------------------------------------------------------------------------------------------------------------------------------------------------------------------------------------------------------------------------------------------------------------------------------------------------------------------------------------------------------------------------------------------------------------------------------------------------------------------------------------------------------------------------------------------------------------------------------------------------------------------------------------------------------------------------------------------------------------------------------------------------------------------------------------------------------------------------------------------------------------------------------------------------------------------------------------------------------------------------------------------------------------------------------------------------------------------------------------------------------------------------------------------------------------------------------------------------------------------------------------------------------------------------------------------------------------------------------------------------------------------------------------------------------------------------------------------------------------------------------------------------------

FRONT SUNROOF SWITCH	30	REMOVAL AND INSTALLATION	48
FRONT SUNROOF SWITCH :		GLASS LID	48
Component Function Check	30	FRONT SUNROOF	48
FRONT SUNROOF SWITCH :		FRONT SUNROOF : Exploded View	48
Diagnosis Procedure	30	FRONT SUNROOF : Removal and Installation	48
FRONT SUNROOF SWITCH : Component In-		FRONT SUNROOF : Adjustment	49
spection	31	REAR SUNROOF	50
REAR SUNROOF SWITCH (FRONT)	31	REAR SUNROOF : Exploded View	50
REAR SUNROOF SWITCH (FRONT) :		REAR SUNROOF : Removal and Installation	51
Component Function Check	31	REAR SUNROOF : Adjustment	51
REAR SUNROOF SWITCH (FRONT) :		SUNROOF MOTOR ASSEMBLY	53
Diagnosis Procedure	31	FRONT SUNROOF	53
REAR SUNROOF SWITCH (FRONT) : Compo-		FRONT SUNROOF : Exploded View	53
nent Inspection	32	FRONT SUNROOF : Removal and Installation	53
REAR SUNROOF SWITCH (REAR)	33	REAR SUNROOF	54
REAR SUNROOF SWITCH (REAR) :		REAR SUNROOF : Exploded View	55
Component Function Check	33	REAR SUNROOF : Removal and Installation	55
REAR SUNROOF SWITCH (REAR) :		SUNROOF UNIT ASSEMBLY	57
Diagnosis Procedure	33	FRONT SUNROOF	57
REAR SUNROOF SWITCH (REAR) : Component		FRONT SUNROOF : Exploded View	57
Inspection	34	FRONT SUNROOF : Removal and Installation	58
SYMPTOM DIAGNOSIS	35	FRONT SUNROOF : Disassembly and Assembly... ..	59
SUNROOF DOES NOT OPERATE PROPER-		REAR SUNROOF	59
LY	35	REAR SUNROOF : Exploded View	59
FRONT SUNROOF	35	REAR SUNROOF : Removal and Installation	61
FRONT SUNROOF : Description	35	REAR SUNROOF : Disassembly and Assembly ...	62
FRONT SUNROOF : Diagnosis Procedure	35	SUNSHADE	63
REAR SUNROOF	36	FRONT SUNROOF	63
REAR SUNROOF : Description	36	FRONT SUNROOF : Exploded View	63
REAR SUNROOF : Diagnosis Procedure	36	FRONT SUNROOF : Removal and Installation	63
AUTO OPERATION DOES NOT OPERATE	38	REAR SUNROOF	64
FRONT SUNROOF	38	REAR SUNROOF : Exploded View	65
FRONT SUNROOF : Description	38	REAR SUNROOF : Removal and Installation	65
FRONT SUNROOF : Diagnosis Procedure	38	WIND DEFLECTOR	67
REAR SUNROOF	38	FRONT SUNROOF	67
REAR SUNROOF : Description	38	FRONT SUNROOF : Exploded View	67
REAR SUNROOF : Diagnosis Procedure	38	FRONT SUNROOF : Removal and Installation	67
SUNROOF DOES NOT OPERATE ANTI-		REAR SUNROOF	68
PINCH FUNCTION	40	REAR SUNROOF : Exploded View	69
Diagnosis Procedure	40	REAR SUNROOF : Removal and Installation	69
RETAINED POWER OPERATION DOES NOT		SUNROOF SWITCH	71
OPERATE PROPERLY	41	FRONT	71
Diagnosis Procedure	41	FRONT : Removal and Installation	71
SQUEAK AND RATTLE TROUBLE DIAG-		REAR	72
NOSES	42	REAR : Removal and Installation	72
Work Flow	42		
Inspection Procedure	44		
Diagnostic Worksheet	46		

PRECAUTIONS

< PRECAUTION >

PRECAUTION

PRECAUTIONS

Precaution for Supplemental Restraint System (SRS) "AIR BAG" and "SEAT BELT PRE-TENSIONER"

INFOID:000000011323084

The Supplemental Restraint System such as "AIR BAG" and "SEAT BELT PRE-TENSIONER", used along with a front seat belt, helps to reduce the risk or severity of injury to the driver and front passenger for certain types of collision. This system includes seat belt switch inputs and dual stage front air bag modules. The SRS system uses the seat belt switches to determine the front air bag deployment, and may only deploy one front air bag, depending on the severity of a collision and whether the front occupants are belted or unbelted. Information necessary to service the system safely is included in the "SRS AIR BAG" and "SEAT BELT" of this Service Manual.

WARNING:

Always observe the following items for preventing accidental activation.

- To avoid rendering the SRS inoperative, which could increase the risk of personal injury or death in the event of a collision that would result in air bag inflation, all maintenance must be performed by an authorized NISSAN/INFINITI dealer.
- Improper maintenance, including incorrect removal and installation of the SRS, can lead to personal injury caused by unintentional activation of the system. For removal of Spiral Cable and Air Bag Module, see "SRS AIR BAG".
- Never use electrical test equipment on any circuit related to the SRS unless instructed to in this Service Manual. SRS wiring harnesses can be identified by yellow and/or orange harnesses or harness connectors.

PRECAUTIONS WHEN USING POWER TOOLS (AIR OR ELECTRIC) AND HAMMERS

WARNING:

Always observe the following items for preventing accidental activation.

- When working near the Air Bag Diagnosis Sensor Unit or other Air Bag System sensors with the ignition ON or engine running, never use air or electric power tools or strike near the sensor(s) with a hammer. Heavy vibration could activate the sensor(s) and deploy the air bag(s), possibly causing serious injury.
- When using air or electric power tools or hammers, always switch the ignition OFF, disconnect the battery, and wait at least 3 minutes before performing any service.

Precaution for Procedure without Cowl Top Cover

INFOID:000000011561458

When performing the procedure after removing cowl top cover, cover the lower end of windshield with urethane, etc to prevent damage to windshield.

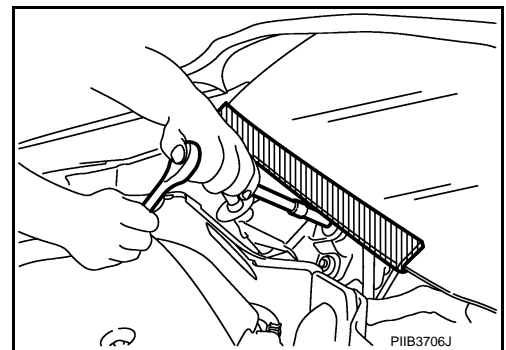

Precautions For Xenon Headlamp Service

INFOID:000000011323085

WARNING:

Comply with the following warnings to prevent any serious accident.

- Disconnect the battery cable (negative terminal) or the power supply fuse before installing, removing, or touching the xenon headlamp (bulb included). The xenon headlamp contains high-voltage generated parts.
- Never work with wet hands.
- Check the xenon headlamp ON-OFF status after assembling it to the vehicle. Never turn the xenon headlamp ON in other conditions. Connect the power supply to the vehicle-side connector.

A
B
C
D
E
F
G
H
I
J
RF
L
M
N
O
P

PRECAUTIONS

< PRECAUTION >

(Turning it ON outside the lamp case may cause fire or visual impairments.)

- Never touch the bulb glass immediately after turning it OFF. It is extremely hot.

CAUTION:

Comply with the following cautions to prevent any error and malfunction.

- Install the xenon bulb securely. (Insufficient bulb socket installation may melt the bulb, the connector, the housing, etc. by high-voltage leakage or corona discharge.)
- Never perform HID circuit inspection with a tester.
- Never touch the xenon bulb glass with hands. Never put oil and grease on it.
- Dispose of the used xenon bulb after packing it in thick vinyl without breaking it.
- Never wipe out dirt and contamination with organic solvent (thinner, gasoline, etc.).

Precautions for Removing Battery Terminal

INFOID:000000011323086

- When removing the 12V battery terminal, turn OFF the ignition switch and wait at least 30 seconds.

NOTE:

ECU may be active for several tens of seconds after the ignition switch is turned OFF. If the battery terminal is removed before ECU stops, then a DTC detection error or ECU data corruption may occur.

- For vehicles with the 2-batteries, be sure to connect the main battery and the sub battery before turning ON the ignition switch.

NOTE:

If the ignition switch is turned ON with any one of the terminals of main battery and sub battery disconnected, then DTC may be detected.

- After installing the 12V battery, always check "Self Diagnosis Result" of all ECUs and erase DTC.

NOTE:

The removal of 12V battery may cause a DTC detection error.

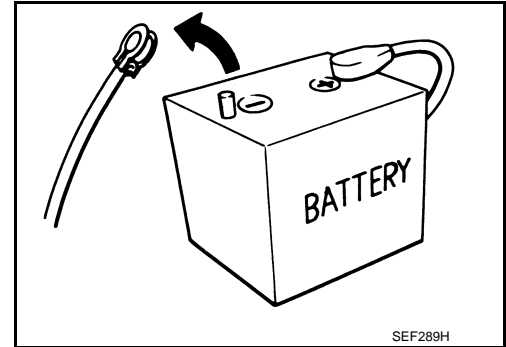

PREPARATION

< PREPARATION >

PREPARATION

PREPARATION

Special Service Tool

INFOID:000000011323087

The actual shapes of TechMate tools may differ from those of special service tools illustrated here.

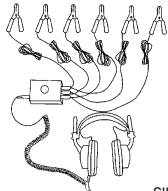
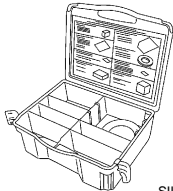
Tool number (TechMate No.) Tool name	Description
(J-39570) Chassis ear  SIIA0993E	Locates the noise
(J-50397) NISSAN Squeak and Rattle Kit  SIIA0994E	Repairs the cause of noise

Commercial Service Tool

INFOID:000000011323088

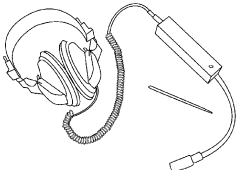
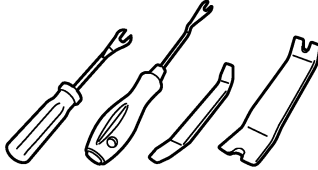
Tool name	Description
Engine ear  SIIA0995E	Locates the noise
Remover tool  JMKIA3050ZZ	Removes the clips, pawls and metal clips

COMPONENT PARTS

< SYSTEM DESCRIPTION >

SYSTEM DESCRIPTION

COMPONENT PARTS

Component Parts Location

INFOID:000000011323089

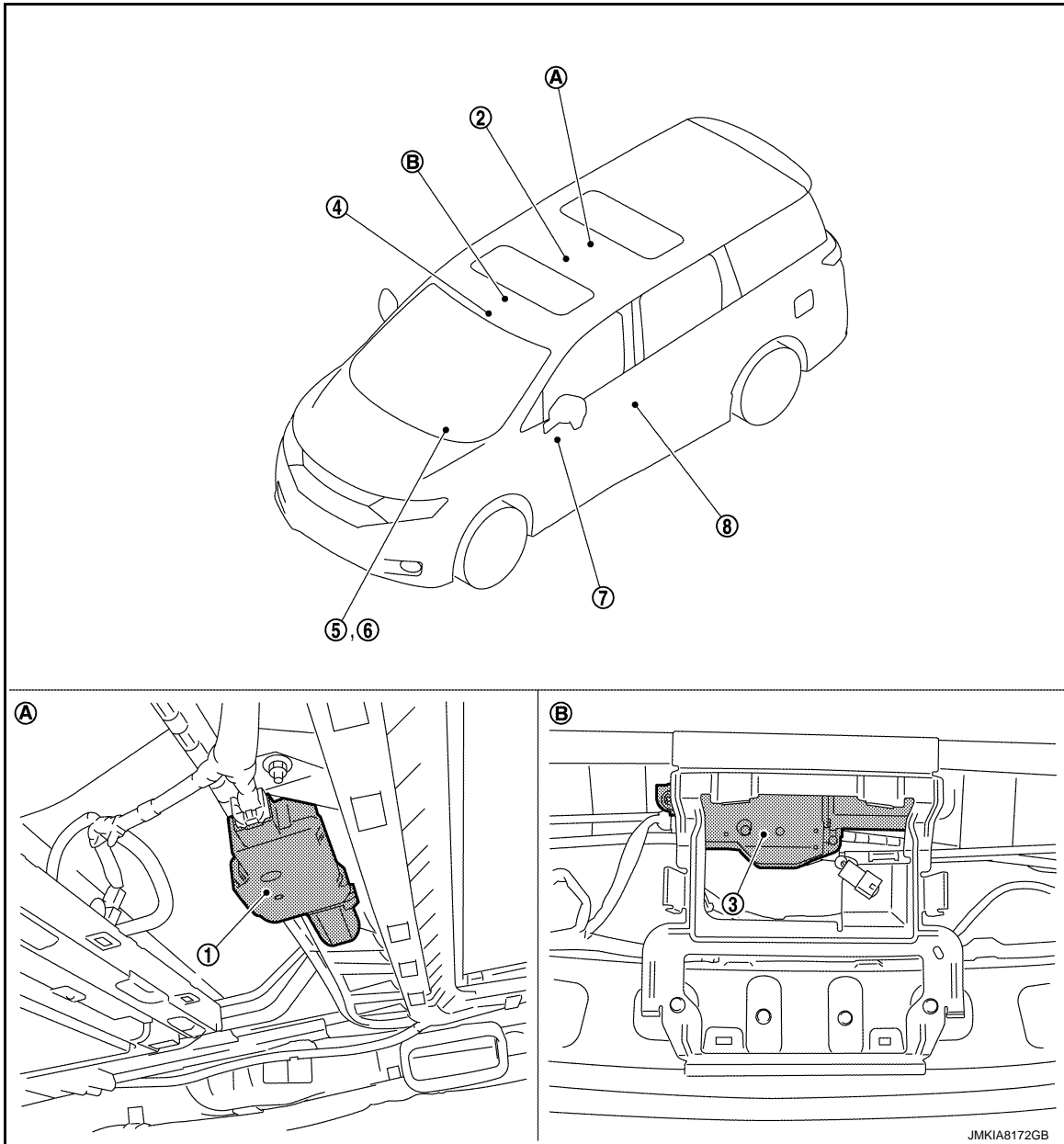

A. View with headlining removed

B. View with headlining removed

No.	Component	Function
1.	Rear sunroof motor assembly	Refer to RF-7, "Rear Sunroof Motor Assembly" .
2.	Rear sunroof switch (rear)	Refer to RF-7, "Rear Sunroof Switch (Rear)" .
3.	Front sunroof motor assembly	Refer to RF-7, "Front Sunroof Motor Assembly" .
4.	Front sunroof switch/rear sunroof switch (front)	Refer to RF-7, "Front Sunroof Switch/Rear Sunroof Switch" .
5.	Combination meter	Transmits vehicle speed signal to front sunroof motor assembly and rear sunroof motor assembly.

COMPONENT PARTS

< SYSTEM DESCRIPTION >

No.	Component	Function
6.	BCM	Supplies the power supply to front sunroof motor assembly and rear sunroof motor assembly. Refer to BCS-4. "BODY CONTROL SYSTEM : Component Parts Location" for detailed installation location.
7.	Power window lock switch (Power window main switch)	Power window lock switch can lock rear sunroof.
8.	Front door switch (driver side)	Detects door open/close condition and transmits to BCM.

Rear Sunroof Motor Assembly

INFOID:0000000011323090

It is rear sunroof motor and CPU integrated type that enables tilt up/down & slide open/close by rear sunroof switch (front/rear) operation.

Rear Sunroof Switch (Rear)

INFOID:0000000011323091

Transmits tilt up/down & slides open/close operation signal to rear sunroof motor assembly.

Front Sunroof Motor Assembly

INFOID:0000000011323092

It is front sunroof motor and CPU integrated type that enables tilt up/down & slide open/close by front sunroof switch operation.

Front Sunroof Switch/Rear Sunroof Switch

INFOID:0000000011323093

Transmits tilt up/down & slides open/close operation signal to front sunroof motor assembly and rear sunroof motor assembly.

A
B
C
D
E
F
G
H
I
J
L
M
N
O
P

RF

SYSTEM

< SYSTEM DESCRIPTION >

SYSTEM

System Description

INFOID:000000011323094

SYSTEM DIAGRAM

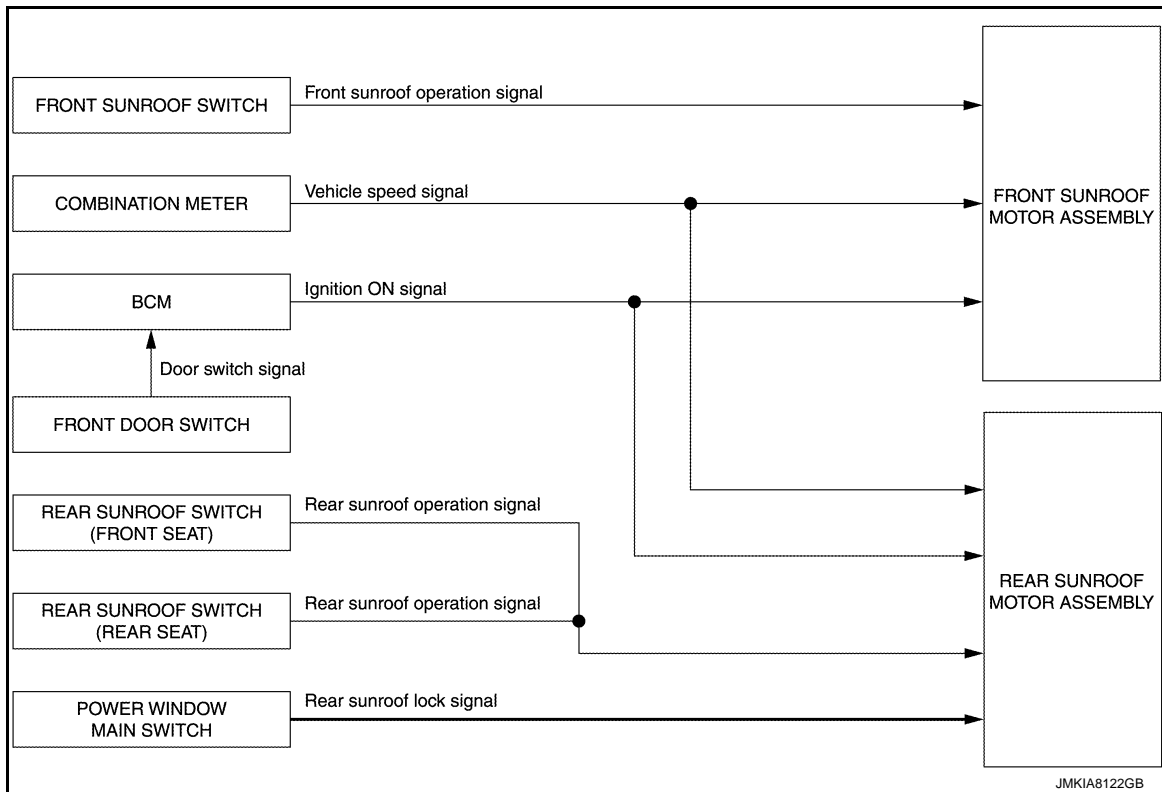



DESCRIPTION

- Sunroof motor assembly operates with the power supply that is output from BCM while ignition switch is ON.
- Tilt up/down and slide open/close signals sunroof switch enables operate sunroof motor to move arbitrarily.
- Sunroof motor assembly receives a vehicle speed signal from combination meter and controls the sunroof motor operation.
- Ground circuit inside power window main switch shuts off when power window lock switch is ON. This inhibits rear sunroof operation.

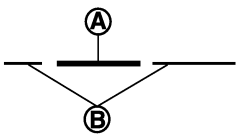

Front Sunroof Operation Description

The front sunroof operate to the following condition by the sunroof switch operation.

Sunroof position before operation	Switch operation	Sunroof action	Sunroof position after operation
Fully-closed  A: Glass lid B: Roof panel JMKA5779ZZ	Close	Tilt up	Tilt up  JMKA5870ZZ
	Open	Open	Fully-open  JMKA5947ZZ

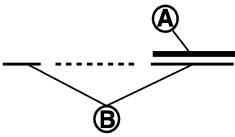
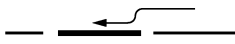
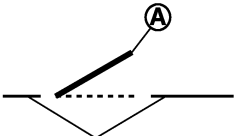

SYSTEM

< SYSTEM DESCRIPTION >

Sunroof position before operation	Switch operation	Sunroof action	Sunroof position after operation
Fully-open  <small>JMKIA5946ZZ</small> A: Glass lid B: Roof panel	Close	Close	Fully-closed  <small>JMKIA5948ZZ</small>
Tilt up  <small>JMKIA5777ZZ</small> A: Glass lid B: Roof panel	Open	Tilt down	Fully-closed  <small>JMKIA5869ZZ</small>

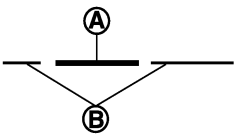

Rear Sunroof Operation Description

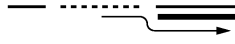
The rear sunroof operate to the following condition by the sunroof switch operation.

Sunroof position before operation	Switch operation	Sunroof action	Sunroof position after operation
Fully-closed  <small>JMKIA5779ZZ</small> A: Glass lid B: Roof panel	Close	Tilt up	Tilt up  <small>JMKIA5870ZZ</small>
	Open	Open	Fully-open  <small>JMKIA5871ZZ</small>

SYSTEM

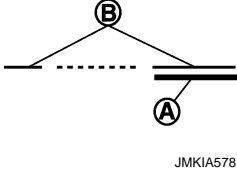
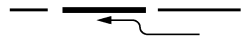
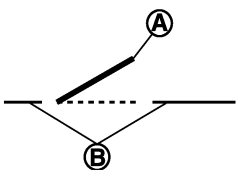
< SYSTEM DESCRIPTION >

Sunroof position before operation	Switch operation	Sunroof action	Sunroof position after operation
<p>Fully-open</p>  <p>A: Glass lid B: Roof panel</p>	Close	Close	<p>Fully-closed</p>  <p>JMKIA5872ZZ</p>
<p>Tilt up</p>  <p>A: Glass lid B: Roof panel</p>	Open	Tilt down	<p>Fully-closed</p>  <p>JMKIA5869ZZ</p>

AUTO OPERATION

- Front sunroof AUTO feature makes it possible to slide open or tilt up the sunroof without holding the front sunroof switch in the slide open or tilt up position.
- Rear sunroof AUTO feature makes it possible to slide open and slide close or tilt up and tilt down the sunroof without holding the rear sunroof switch (front/rear) in the slide open/tilt down or slide close/tilt up position.

NOTE:

- Auto operation can not be performed under the non-initialized condition.
- Auto operation is not available for tilt down and slide close of front sunroof.

Retained Power Operation

Retained power operation is an additional power supply function that enables sunroof system to operate for 45 seconds period after ignition switch is turned OFF.

Retained power function cancel conditions

- Front door CLOSE (door switch OFF) → OPEN (door switch ON)
- Ignition switch is ON again
- Timer passed (45 seconds)

ANTI-PINCH FUNCTION

The CPU of sunroof motor assembly monitors the sunroof motor operation and the sunroof position (fully-closed or other) by the signals from sunroof motor.

When sunroof motor detects an interruption during the following slide close and tilt down operation, sunroof switch controls the motor for open and the sunroof will operate until full up position (when tilt down operate) or 150 mm (5.91 in) or more in an open direction (when slide close operate).

NOTE:

Depending on environment and driving conditions, if a similar impact or load is applied to the sunroof, it may lower.

SYSTEM

< SYSTEM DESCRIPTION >

Circuit Diagram

INFOID:000000011323095

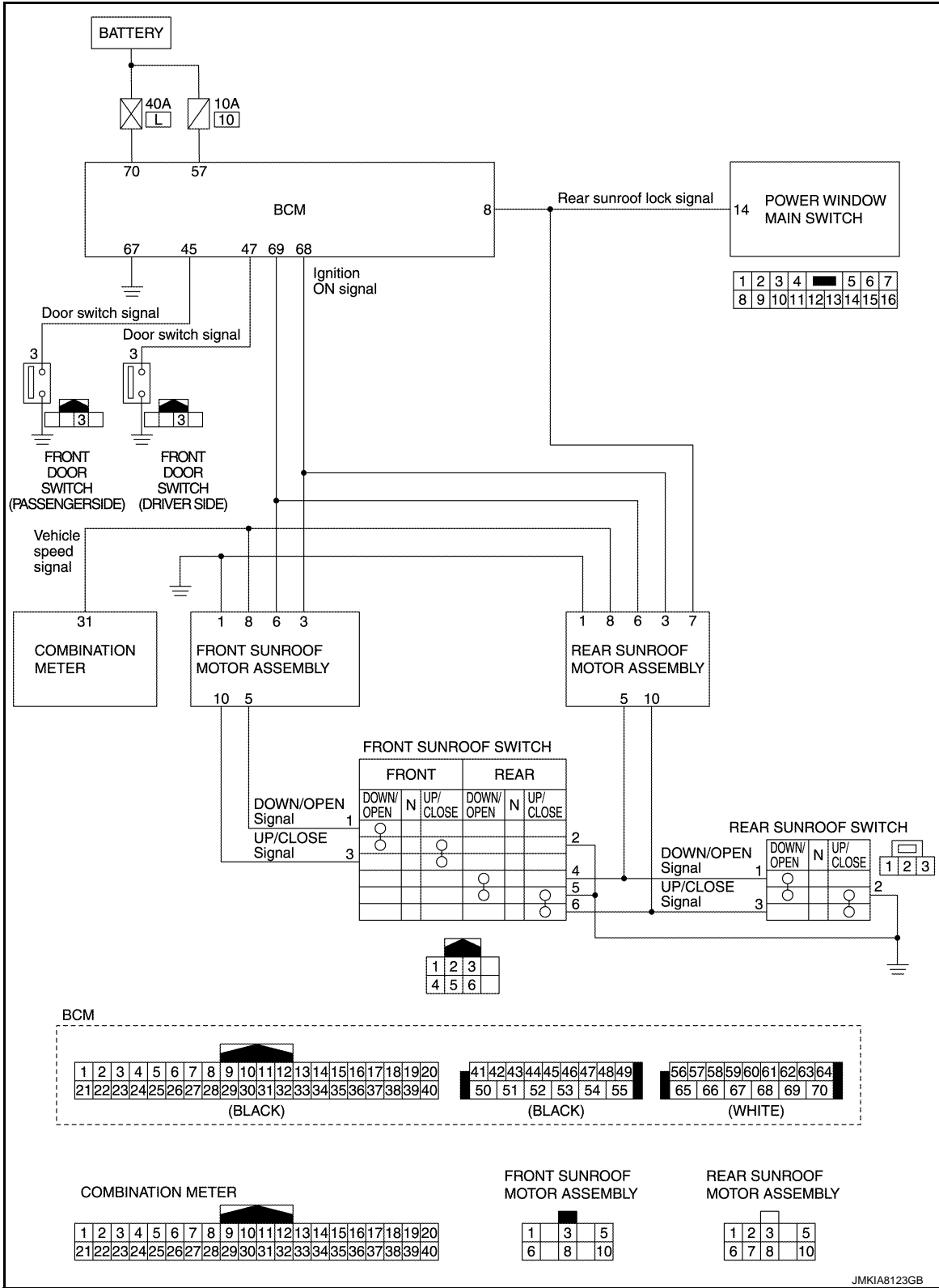

BCM (BODY CONTROL MODULE)

< ECU DIAGNOSIS INFORMATION >

ECU DIAGNOSIS INFORMATION

BCM (BODY CONTROL MODULE)

List of ECU Reference

INFOID:000000011323096

ECU	Reference
BCM	BCS-40. "Reference Value"
	BCS-62. "Fail-safe"
	BCS-62. "DTC Inspection Priority Chart"
	BCS-63. "DTC Index"

FRONT SUNROOF MOTOR ASSEMBLY

< ECU DIAGNOSIS INFORMATION >

FRONT SUNROOF MOTOR ASSEMBLY

Reference Value

INFOID:000000011323097

TERMINAL LAYOUT

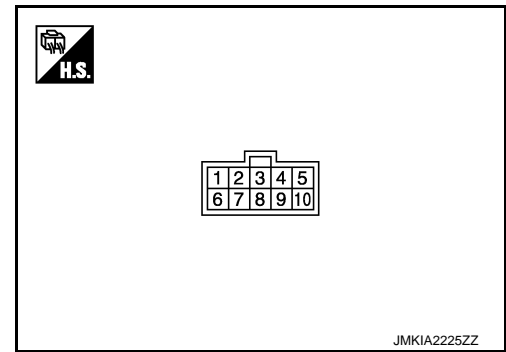

PHYSICAL VALUES

Terminal No. (Wire color)		Description		Condition	Voltage
+	-	Signal name	Input/ Output		
1 (B)	Ground	Ground	—	—	—
3 (V)	Ground	Ignition ON signal	Input	Ignition switch ON	Battery voltage
				Other than the above	0 V
5 (LG)	Ground	Front sunroof switch (DOWN/OPEN signal)	Input	Sunroof switch in following position • TILT DOWN • SLIDE OPEN	0 V
				Other than the above	Battery voltage
6 (L)	Ground	Sunroof power supply	Input	—	Battery voltage
8 (Y)	Ground	Vehicle speed signal	Input	Speedometer operated [When vehicle speed is approx.40 km/ h (25 MPH)]	
					JSNIA0012GB
10 (V)	Ground	Front sunroof switch (UP/CLOSE signal)	Input	Sunroof switch in following position • TILT UP • SLIDE CLOSE	0 V
				Other than the above	Battery voltage

REAR SUNROOF MOTOR ASSEMBLY

< ECU DIAGNOSIS INFORMATION >

REAR SUNROOF MOTOR ASSEMBLY

Reference Value

INFOID:000000011323098

TERMINAL LAYOUT

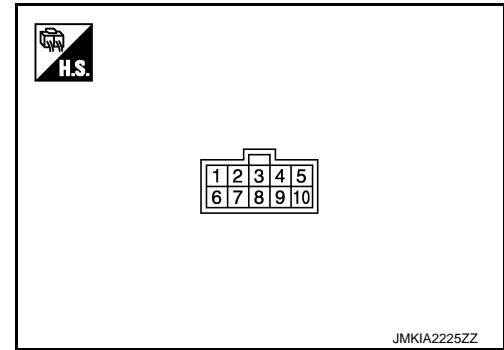

PHYSICAL VALUES

Terminal No. (Wire color)		Description		Condition	Voltage
+	-	Signal name	Input/ Output		
1 (B)	Ground	Ground	—	—	—
3 (V)	Ground	Ignition ON signal	Input	Ignition switch ON	Battery voltage
				Other than the above	0 V
5 (BR)	Ground	Rear sunroof switch (DOWN/OPEN signal)	Input	Sunroof switch in following position • TILT DOWN • SLIDE OPEN	0 – 3 V
				Other than the above	Battery voltage
6 (L)	Ground	Sunroof power supply	Input	—	Battery voltage
7 (SB)	Ground	Rear sunroof lock signal	Input/ Output	<ul style="list-style-type: none"> Ignition switch ON Within 45 second after ignition switch is turned to OFF 	<p style="text-align: right;">JPMIA0013GB</p>
8 (Y)	Ground	Vehicle speed signal	Input	Speedometer operated [When vehicle speed is approx. 40 km/h (25 MPH)]	<p style="text-align: right;">JSNIA0012GB</p>
10 (SB)	Ground	Rear sunroof switch (UP/CLOSE signal)	Input	Sunroof switch in following position • TILT UP • SLIDE CLOSE	0 – 3 V
				Other than the above	Battery voltage

SUNROOF MOTOR ASSEMBLY

< WIRING DIAGRAM >

WIRING DIAGRAM

SUNROOF MOTOR ASSEMBLY

Wiring Diagram

INFOID:000000011323099

SUNROOF

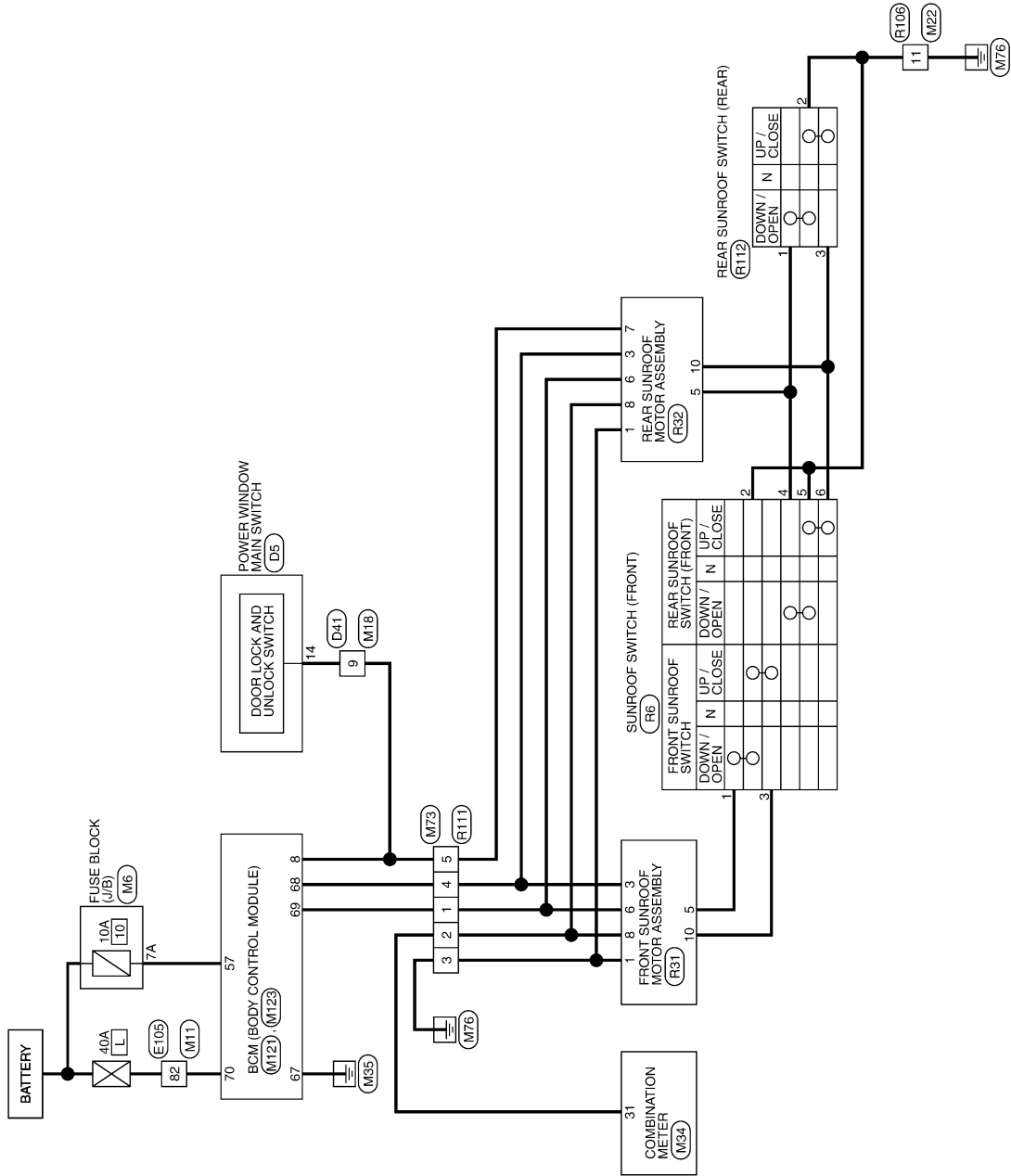

2014/07/25

JRKWE1600GB

A
B
C
D
E
F
G
H
I
J
RF
L
M
N
O
P

SUNROOF MOTOR ASSEMBLY

< WIRING DIAGRAM >

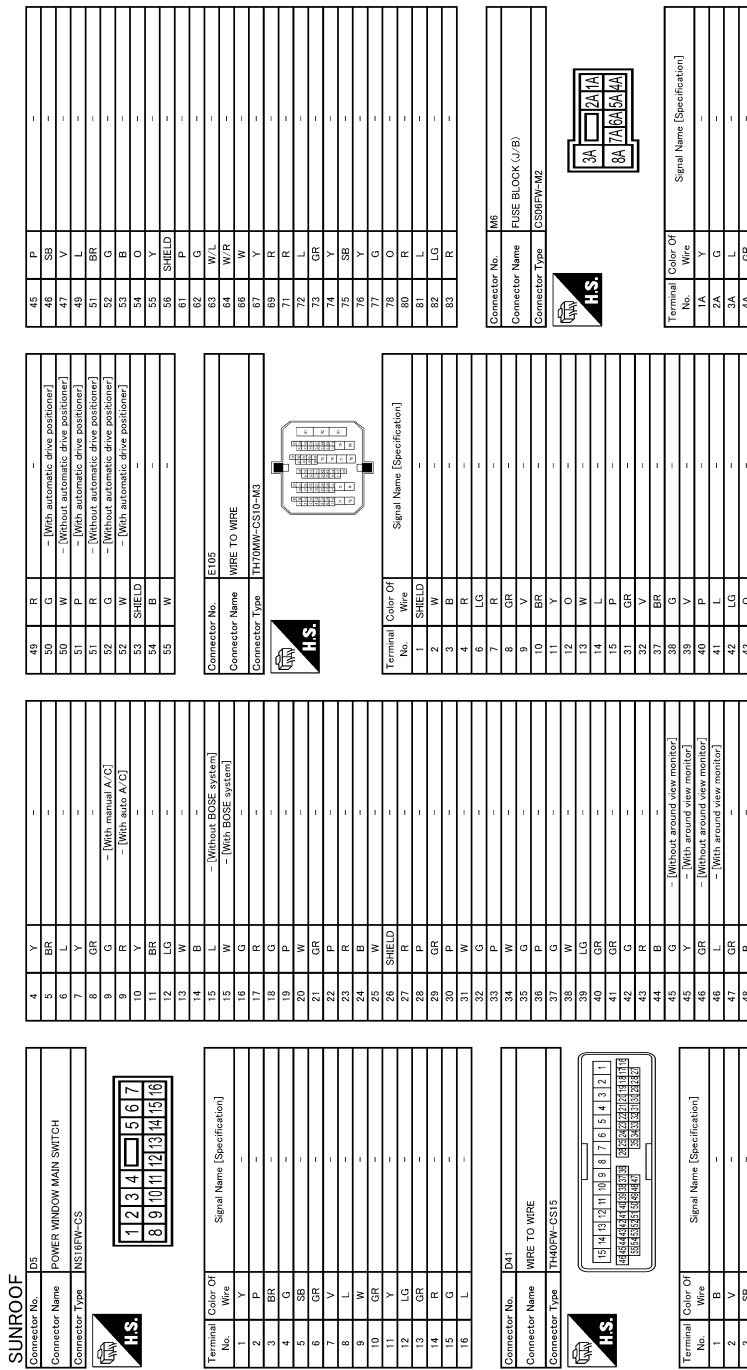

JRKWE1601GB

SUNROOF MOTOR ASSEMBLY

< WIRING DIAGRAM >

Terminal No.	Color Of Wire	Signal Name [Specification]
1	SHIELD	-
2	W	-
3	B	-
4	R	-
6	G	-
7	R	-
8	G	-
9	B	-
10	R	-
11	W	-
12	LG	- [Without automatic drive positioner] - [With automatic drive positioner]
13	G	- [Without automatic drive positioner] - [With automatic drive positioner]
14	Y	-
15	P	-
31	R	-
32	LG	- [Without automatic drive positioner] - [With automatic drive positioner]
33	Y	-
34	L	-
35	Y	-
36	V	-
37	P	-
38	BR	-
60	Y	-
81	W	-
82	L	-
83	R	-

Terminal No.	Color Of Wire	Signal Name [Specification]
49	G	-
50	G	-
51	W	-
52	B	-
53	B	-
54	LG	-
55	L	-
56	SHIELD	-
61	R	-
62	W	-
63	B	-
64	W	-
66	W	-
67	BR	-
69	P	-
71	R	-
72	L	-
73	LG	-
74	Y	-
75	Y	-
76	V	-
77	P	-
78	BR	-
80	Y	-
81	W	-
82	L	-
83	R	-

Terminal No.	Color Of Wire	Signal Name [Specification]
9	GR	-
10	Y	-
11	Y	-
12	G	-
13	G	-
14	B	-
15	W	-
16	Y	-
17	BE	-
18	P	-
19	W	-
20	LG	-
21	P	-
22	R	-
23	R	-
24	B	-
25	W	-
26	SHIELD	-
27	Y	-
28	G	-
29	W	-
30	R	-
31	W	-
32	G	-
33	BE	-
34	P	-
35	V	-
36	W	-
37	W	-
38	P	-
39	V	-
40	R	-
41	B	-
42	W	-
43	G	-
44	B	-
45	B	-
46	R	-
47	R	-
48	R	-
49	W	-
50	GR	-
51	GR	-
52	P	-
53	Y	-
54	P	-
55	W	-
56	W	-
57	B	-
58	V	-
59	B	-
60	L	-

SUNROOF

3A	V	-
7A	GR	-
8A	L	-

Connector No.	M11
Connector Name	WIRE TO WIRE
Connector Type	TH10PW-CS10-M3

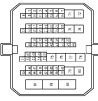

Terminal No.	Color Of Wire	Signal Name [Specification]
1	SHIELD	-
2	W	-
3	B	-
4	R	-
6	G	-
7	R	-
8	G	-
9	B	-
10	R	-
11	W	-
12	LG	- [Without automatic drive positioner] - [With automatic drive positioner]
13	G	- [Without automatic drive positioner] - [With automatic drive positioner]
14	L	-
15	P	-
31	R	-
32	LG	-
37	BR	- [With automatic drive positioner] - [Without automatic drive positioner]
38	R	-
39	BE	- [Without automatic drive positioner] - [With automatic drive positioner]
40	P	-
41	L	-
42	G	-
43	W	-
45	P	-
46	V	-
47	R	-

Connector No.	M18
Connector Name	WIRE TO WIRE
Connector Type	TH40MW-CS15

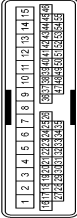

Terminal No.	Color Of Wire	Signal Name [Specification]
1	B	-
2	W	-
3	W	-
4	Y	-
5	SB	-
6	LG	-
7	V	-
8	L	-

52	GR	- [Without automatic drive positioner] - [With automatic drive positioner]
53	SHIELD	-
54	W	-
55	B	-

Connector No.	M22
Connector Name	WIRE TO WIRE
Connector Type	TH18PW-NH

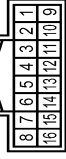

Terminal No.	Color Of Wire	Signal Name [Specification]
1	G	-
2	W	-
3	G	-
4	P	-
6	R	-
7	BE	-
8	Y	-
9	P	-
10	GR	-
11	GR	-
12	GR	-
13	P	-
14	B	-
15	SHIELD	-
16	W	-

JRKWE1602GB

A B C D E F G H I J RF L M N O P

SUNROOF MOTOR ASSEMBLY

< WIRING DIAGRAM >

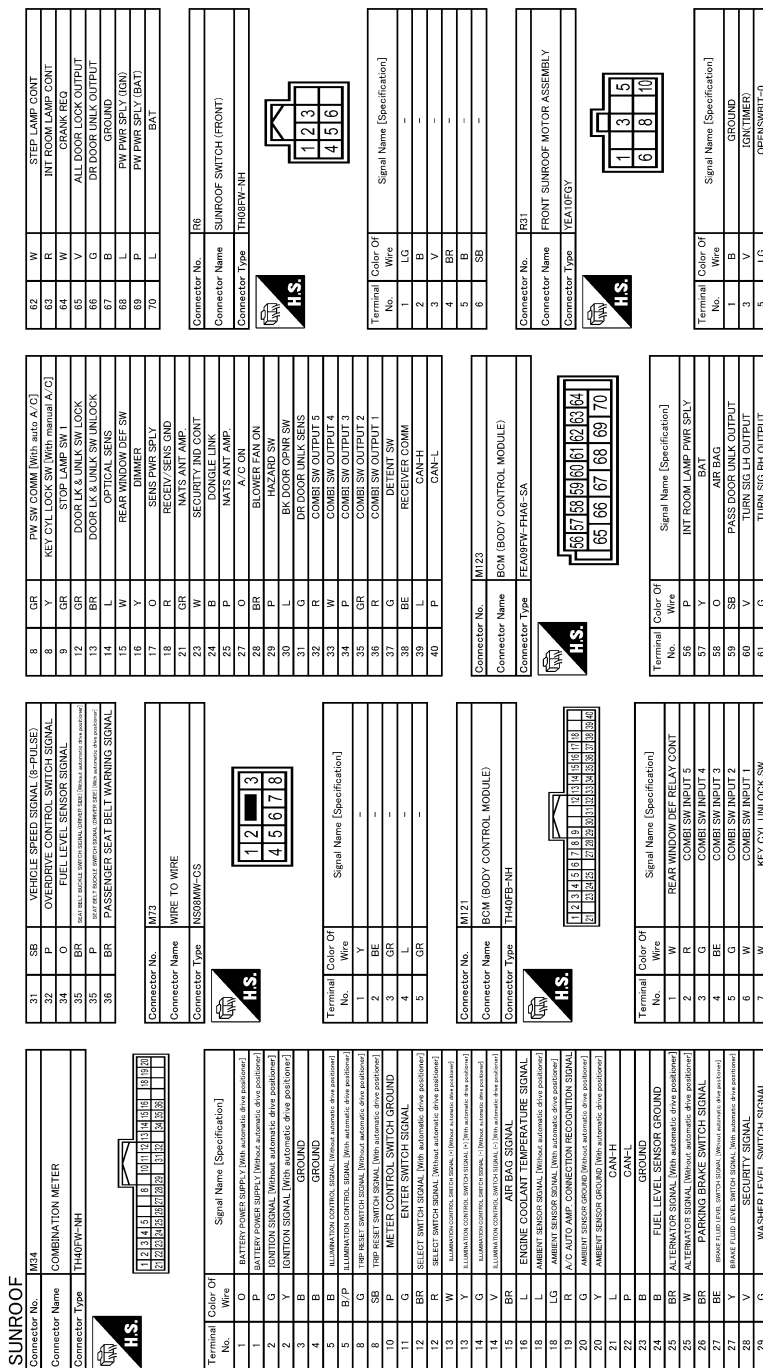

SUNROOF MOTOR ASSEMBLY

< WIRING DIAGRAM >

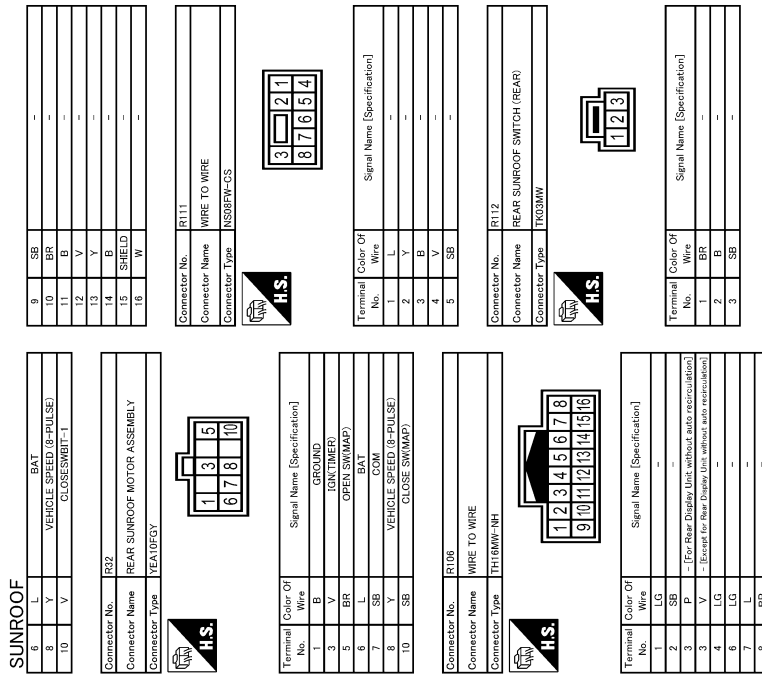

A
B
C
D
E
F
G
H
I
J
RF
L
M
N
O
P

DIAGNOSIS AND REPAIR WORKFLOW

< BASIC INSPECTION >

BASIC INSPECTION

DIAGNOSIS AND REPAIR WORKFLOW

WorkFlow

INFOID:000000011323100

DETAILED FLOW

1.OBTAIN INFORMATION ABOUT SYMPTOM

Interview the customer to obtain the malfunction information (conditions and environment when the malfunction occurred) as much as possible when the customer brings the vehicle in.

>> GO TO 2.

2.REPRODUCE THE MALFUNCTION INFORMATION

Check the malfunction on the vehicle that the customer describes.
Inspect the relation of the symptoms and the condition when the symptoms occur.

>> GO TO 3.

3.IDENTIFY THE MALFUNCTIONING SYSTEM WITH "SYMPTOM DIAGNOSIS"

Use "Symptom diagnosis" from the symptom inspection result in step 2 and then identify where to start performing the diagnosis based on possible causes and symptoms.

>> GO TO 4.

4.IDENTIFY THE MALFUNCTIONING PARTS WITH "COMPONENT DIAGNOSIS"

Perform the diagnosis with "Component diagnosis" of the applicable system.

>> GO TO 5.

5.REPAIR OR REPLACE THE MALFUNCTIONING PARTS

Repair or replace the specified malfunctioning parts.

>> GO TO 6.

6.FINAL CHECK

Check that malfunctions are not reproduced when obtaining the malfunction information from the customer, referring to the symptom inspection result in step 2.

Are the malfunctions corrected?

YES >> INSPECTION END

NO >> GO TO 3.

INSPECTION AND ADJUSTMENT

< BASIC INSPECTION >

INSPECTION AND ADJUSTMENT

FRONT SUNROOF

FRONT SUNROOF : Description

INFOID:0000000011323101

MEMORY RESET PROCEDURE

Initialization of system should be conducted after the following conditions.

- When the front sunroof motor is changed.
- When the front sunroof does not open automatically.

FRONT SUNROOF : Special Repair Requirement

INFOID:0000000011323102

INITIALIZATION PROCEDURE

1. Press front sunroof switch toward tilt up side and set glass lid to the tilt up position.
2. Release the front sunroof switch, press the front sunroof switch toward tilt up side again, press and hold the switch for 10 seconds or more until glass lid starts to move.
3. Release the front sunroof switch once, press and hold the front sunroof switch toward tilt up side.
4. The glass lid moves little by little and closes. (Press and hold the switch during this operation)
5. After the glass lid stops, release the front sunroof switch, and within the first 4 seconds, press and hold front sunroof switch toward tilt up side.
6. After 4 seconds, the glass lid automatically operates in sequence of slide open and slide close.
7. When the glass lid stops, release the front sunroof switch after 0.5 second or more.
8. Operate front sunroof switch, and if front sunroof is operated normally, the initialization is complete.

REAR SUNROOF

REAR SUNROOF : Description

INFOID:0000000011323103

MEMORY RESET PROCEDURE

Initialization of system should be conducted after the following conditions.

- When the rear sunroof motor is changed.
- When the rear sunroof does not open or close automatically.

REAR SUNROOF : Special Repair Requirement

INFOID:0000000011323104

INITIALIZATION PROCEDURE

1. Press rear sunroof switch (front or rear) toward tilt up side and set glass lid to the tilt up position.
2. Release the rear sunroof switch, press the rear sunroof switch toward tilt up side again, press and hold the switch for 10 seconds or more until glass lid starts to move.
3. The glass lid moves slightly toward tilt up direction then stops. (Press and hold the rear sunroof switch during this operation).
4. Release the rear sunroof switch once, press and hold the rear sunroof switch (tilt up side) within the first 4 seconds.
5. After 4 seconds, the glass lid automatically operates in sequence of tilt down, slide open and slide close.
6. When the glass lid stops, release the rear sunroof switch after 0.5 seconds or more.
7. Operate front sunroof switch, and if front sunroof is operated normally, the initialization is complete.

ANTI-PINCH FUNCTION

1. Full open the sunroof.
2. Place a wooden piece (wooden hammer handle, etc.) at near fully closed position.
3. Close the sunroof completely with auto-slide close.

Check that sunroof lowers for approximately 150 mm (5.91in) with out pinching a wooden piece and stops.

CAUTION:

- **Never check with hands and other part of body because they may be pinched. Never get pinched.**
- **Depending on environment and driving conditions, if a similar impact or load is applied to the sunroof it may lower.**
- **Check that auto-slide operates before inspection when system initialization is performed.**
- **Perform initial setting when auto-slide operation or anti-pinch function does not operate normally.**

A
B
C
D
E
F
G
H
I
J
RF

POWER SUPPLY AND GROUND CIRCUIT

< DTC/CIRCUIT DIAGNOSIS >

DTC/CIRCUIT DIAGNOSIS

POWER SUPPLY AND GROUND CIRCUIT FRONT SUNROOF MOTOR ASSEMBLY

FRONT SUNROOF MOTOR ASSEMBLY : Diagnosis Procedure

INFOID:000000011323105

1.CHECK POWER SUPPLY

1. Turn ignition switch OFF.
2. Disconnect front sunroof motor assembly and rear sunroof motor assembly harness connector.
3. Turn ignition switch ON.
4. Check voltage between front sunroof motor assembly harness connector and ground.

(+)		(-)	Voltage (V)
Front sunroof motor assembly			
Connector	Terminal		
R31	6	Ground	Battery voltage

Is the inspection result normal?

- YES >> GO TO 3.
NO >> GO TO 2.

2.CHECK POWER SUPPLY CIRCUIT

1. Turn ignition switch OFF.
2. Disconnect BCM harness connector.
3. Check continuity between BCM harness connector and front sunroof motor assembly harness connector.

BCM		Front sunroof motor assembly		Continuity
Connector	Terminal	Connector	Terminal	
M123	69	R31	6	Existed

4. Check continuity between BCM harness connector and ground.

BCM		Ground	Continuity
Connector	Terminal		
M123	69		Not existed

Is the inspection result normal?

- YES >> Check BCM power supply and ground circuit. Refer to [BCS-91, "Diagnosis Procedure"](#).
NO >> Repair or replace harness.

3.CHECK GROUND CIRCUIT

1. Turn ignition switch OFF.
2. Check continuity between front sunroof motor assembly harness connector and ground.

Front sunroof motor assembly		Ground	Continuity
Connector	Terminal		
R31	1		Existed

Is the inspection result normal?

- YES >> INSPECTION END
NO >> Repair or replace harness.

REAR SUNROOF MOTOR ASSEMBLY

REAR SUNROOF MOTOR ASSEMBLY : Diagnosis Procedure

INFOID:000000011323106

1.CHECK POWER SUPPLY

POWER SUPPLY AND GROUND CIRCUIT

< DTC/CIRCUIT DIAGNOSIS >

1. Turn ignition switch OFF.
2. Disconnect front sunroof motor assembly and rear sunroof motor assembly harness connector.
3. Turn ignition switch ON.
4. Check voltage between rear sunroof motor assembly harness connector and ground.

(+)		(-)	Voltage (V)
Rear sunroof motor assembly			
Connector	Terminal	Ground	Battery voltage
R32	6		

Is the inspection result normal?

YES >> GO TO 3.

NO >> GO TO 2.

2.CHECK POWER SUPPLY CIRCUIT

1. Turn ignition switch OFF.
2. Disconnect BCM harness connector.
3. Check continuity between BCM harness connector and rear sunroof motor assembly harness connector.

BCM		Rear sunroof motor assembly		Continuity
Connector	Terminal	Connector	Terminal	
M123	69	R32	6	Existed

4. Check continuity between BCM harness connector and ground.

BCM		Ground	Continuity
Connector	Terminal		
M123	69		Not existed

Is the inspection result normal?

YES >> Check BCM power supply and ground circuit. Refer to [BCS-91. "Diagnosis Procedure"](#).

NO >> Repair or replace harness.

3.CHECK GROUND CIRCUIT

1. Turn ignition switch OFF.
2. Check continuity between rear sunroof motor assembly harness connector and ground.

Rear sunroof motor assembly		Ground	Continuity
Connector	Terminal		
R32	1		Existed

Is the inspection result normal?

YES >> INSPECTION END

NO >> Repair or replace harness.

FRONT SUNROOF MOTOR ASSEMBLY

< DTC/CIRCUIT DIAGNOSIS >

FRONT SUNROOF MOTOR ASSEMBLY

Component Function Check

INFOID:000000011323107

1.CHECK FUNCTION-I

Check tilt up/down and slide open/close operations with front sunroof switch.

Is the inspection result normal?

- YES >> GO TO 3.
- NO >> GO TO 2.

2.CHECK FUNCTION-II

1. Perform initialization procedure. Refer to [RF-21. "FRONT SUNROOF : Special Repair Requirement"](#).
2. Check tilt up/down and slide open/close operations with front sunroof switch.

Is the inspection result normal?

- YES >> GO TO 3.
- NO >> Refer to [RF-24. "Diagnosis Procedure"](#).

3.CHECK FUNCTION-III

1. Start engine.
2. Drive the vehicle at more than 40 km/h (25 MPH).

CAUTION:

Always drive vehicle at a safe speed.

NOTE:

This procedure may be conducted with the drive wheels lifted in the shop or by driving the vehicle. If a road test is expected to be easier, it is unnecessary to lift the vehicle.

3. Check tilt up/down and slide open/close operations with front sunroof switch.

Is the inspection result normal?

- YES >> INSPECTION END
- NO >> Refer to [RF-24. "Diagnosis Procedure"](#).

Diagnosis Procedure

INFOID:000000011323108

1.CHECK IGNITION ON SIGNAL

1. Turn ignition switch OFF.
2. Disconnect front sunroof motor assembly and rear sunroof motor assembly harness connector.
3. Turn ignition switch ON.
4. Check voltage between front sunroof motor assembly harness connector and ground.

(+)		(-)	Voltage (V)
Front sunroof motor assembly			
Connector	Terminal		
R31	3	Ground	Battery voltage

Is the inspection result normal?

- YES >> GO TO 3.
- NO >> GO TO 2.

2.CHECK IGNITION ON SIGNAL CIRCUIT

1. Turn ignition switch OFF.
2. Disconnect BCM harness connector.
3. Check continuity between BCM harness connector and front sunroof motor assembly harness connector.

BCM		Front sunroof motor assembly		Continuity
Connector	Terminal	Connector	Terminal	
M123	68	R31	3	Existed

4. Check continuity between BCM harness connector and ground.

FRONT SUNROOF MOTOR ASSEMBLY

< DTC/CIRCUIT DIAGNOSIS >

BCM		Ground	Continuity
Connector	Terminal		
M123	68		Not existed

Is the inspection result normal?

- YES >> Check BCM power supply and ground circuit. Refer to [BCS-91, "Diagnosis Procedure"](#).
 NO >> Repair or replace harness.

3. CHECK VEHICLE SPEED SIGNAL CIRCUIT

1. Turn ignition switch OFF.
2. Disconnect combination meter harness connector.
3. Check continuity between front sunroof motor assembly harness connector and combination meter harness connector.

Front sunroof motor assembly		Combination meter		Continuity
Connector	Terminal	Connector	Terminal	
R31	8	M34	31	Exists

4. Check continuity between front sunroof motor assembly harness connector and ground.

Front sunroof motor assembly		Ground	Continuity
Connector	Terminal		
R31	8		Not existed

Is the inspection result normal?

- YES >> GO TO 4.
 NO >> Repair or replace harness.

4. CHECK COMBINATION METER

Check combination meter.
 Refer to [MWI-68, "DTC Logic"](#).

Is the inspection result normal?

- YES >> Replace front sunroof motor assembly. Refer to [RF-53, "FRONT SUNROOF : Removal and Installation"](#).
 NO >> Repair or replace malfunctioning parts.

A
B
C
D
E
F
G
H
I
J
RF
L
M
N
O
P



REAR SUNROOF MOTOR ASSEMBLY

< DTC/CIRCUIT DIAGNOSIS >

REAR SUNROOF MOTOR ASSEMBLY

Component Function Check

INFOID:000000011323109

1.CHECK FUNCTION-I

Check tilt up/down and slide open/close operations with rear sunroof switch (front/rear).

Is the inspection result normal?

- YES >> GO TO 3.
- NO >> GO TO 2.

2.CHECK FUNCTION-II

1. Perform initialization procedure. Refer to [RF-21. "REAR SUNROOF : Special Repair Requirement"](#).
2. Check tilt up/down and slide open/close operations with rear sunroof switch (front/rear).

Is the inspection result normal?

- YES >> GO TO 3.
- NO >> Refer to [RF-26. "Diagnosis Procedure"](#).

3.CHECK FUNCTION-III

1. Start engine.
2. Drive the vehicle at more than 40 km/h (25 MPH).

CAUTION:

Always drive vehicle at a safe speed.

NOTE:

This procedure may be conducted with the drive wheels lifted in the shop or by driving the vehicle. If a road test is expected to be easier, it is unnecessary to lift the vehicle.

3. Check tilt up/down and slide open/close operations with rear sunroof switch (front/rear).

Is the inspection result normal?

- YES >> INSPECTION END
- NO >> Refer to [RF-26. "Diagnosis Procedure"](#).

Diagnosis Procedure

INFOID:000000011323110

1.CHECK IGNITION ON SIGNAL

1. Turn ignition switch OFF.
2. Disconnect front sunroof motor assembly and rear sunroof motor assembly harness connector.
3. Turn ignition switch ON.
4. Check voltage between rear sunroof motor assembly harness connector and ground.

(+)		(-)	Voltage (V)
Rear sunroof motor assembly			
Connector	Terminal		
R32	3	Ground	Battery voltage

Is the inspection result normal?

- YES >> GO TO 3.
- NO >> GO TO 2.

2.CHECK IGNITION ON SIGNAL CIRCUIT

1. Turn ignition switch OFF.
2. Disconnect BCM harness connector.
3. Check continuity between BCM harness connector and rear sunroof motor assembly harness connector.

BCM		Rear sunroof motor assembly		Continuity
Connector	Terminal	Connector	Terminal	
M123	68	R32	3	Existed

4. Check continuity between BCM harness connector and ground.

REAR SUNROOF MOTOR ASSEMBLY

< DTC/CIRCUIT DIAGNOSIS >

BCM		Ground	Continuity
Connector	Terminal		
M123	68		Not existed

Is the inspection result normal?

- YES >> Check BCM power supply and ground circuit. Refer to [BCS-91, "Diagnosis Procedure"](#).
 NO >> Repair or replace harness.

3. CHECK VEHICLE SPEED SIGNAL CIRCUIT

- Turn ignition switch OFF.
- Disconnect combination meter harness connector.
- Check continuity between rear sunroof motor assembly harness connector and combination meter harness connector.

Rear sunroof motor assembly		Combination meter		Continuity
Connector	Terminal	Connector	Terminal	
R32	8	M34	31	Exists

- Check continuity between rear sunroof motor assembly harness connector and ground.

Rear sunroof motor assembly		Ground	Continuity
Connector	Terminal		
R32	8		Not existed

Is the inspection result normal?

- YES >> GO TO 4.
 NO >> Repair or replace harness.

4. CHECK COMBINATION METER

Check combination meter.
 Refer to [MWI-68, "DTC Logic"](#).

Is the inspection result normal?

- YES >> Replace rear sunroof motor assembly. Refer to [RF-55, "REAR SUNROOF : Removal and Installation"](#).
 NO >> Repair or replace malfunctioning parts.

POWER WINDOW SERIAL LINK

< DTC/CIRCUIT DIAGNOSIS >

POWER WINDOW SERIAL LINK

Component Function Check

INFOID:000000011323111

1.CHECK FUNCTION

Check that the function operates normally according to the following conditions.

Power window main switch (power window lock switch)	Rear sunroof
ON (LOCK)	Operate
OFF (UNLOCK)	Non-operation

Is the inspection result normal?

YES >> INSPECTION END

NO >> Refer to [RF-28. "Diagnosis Procedure"](#).

Diagnosis Procedure

INFOID:000000011323112

1.CHECK REAR SUNROOF MOTOR ASSEMBLY INPUT SIGNAL

1. Turn ignition switch ON.
2. Check signal between rear sunroof motor assembly harness connector and ground.

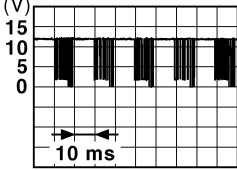
(+)		(-)	Signal (Reference value)
Connector	Terminal		
R32	7	Ground	 <p style="text-align: right; font-size: small;">JPMIA0013GB</p>

Is the inspection result normal?

YES >> Check intermittent incident. Refer to [GI-42. "Intermittent Incident"](#).

NO >> GO TO 2.

2.CHECK REAR SUNROOF MOTOR ASSEMBLY SERIAL LINK CIRCUIT-I

1. Turn ignition switch OFF.
2. Disconnect rear sunroof motor assembly and power window main switch harness connector.
3. Turn ignition switch ON.
4. Check voltage between rear sunroof motor assembly harness connector and ground.

(+)		(-)	Voltage (V)
Connector	Terminal		
R32	7	Ground	Battery voltage

Is the inspection result normal?

YES >> GO TO 4.

NO >> GO TO 3.

3.CHECK REAR SUNROOF MOTOR ASSEMBLY SERIAL LINK CIRCUIT-II

1. Turn ignition switch OFF.
2. Disconnect BCM harness connector.
3. Check continuity between BCM harness connector and rear sunroof motor assembly harness connector.

POWER WINDOW SERIAL LINK

< DTC/CIRCUIT DIAGNOSIS >

BCM		Rear sunroof motor assembly		Continuity
Connector	Terminal	Connector	Terminal	
M121	8	R32	7	Existed

4. Check continuity between BCM harness connector and ground.

BCM		Ground	Continuity
Connector	Terminal		
M121	8		Not existed

Is the inspection result normal?

- YES >> Replace BCM. Refer to [BCS-98, "Removal and Installation"](#).
- NO >> Repair or replace harness.

4.CHECK POWER WINDOW MAIN SWITCH

Check power window main switch.

Refer to [PWC-52, "POWER WINDOW MAIN SWITCH : Diagnosis Procedure"](#).

Is the inspection result normal?

- YES >> Replace rear sunroof motor assembly. Refer to [RF-55, "REAR SUNROOF : Removal and Installation"](#).
- NO >> Repair or replace the malfunctioning parts.

A
B
C
D
E
F
G
H
I
J
L
M
N
O
P

RF

SUNROOF SWITCH

< DTC/CIRCUIT DIAGNOSIS >

SUNROOF SWITCH

FRONT SUNROOF SWITCH

FRONT SUNROOF SWITCH : Component Function Check

INFOID:0000000011323113

1.CHECK FUNCTION

Check tilt up/down and slide open/close operations with front sunroof switch.

Is the inspection result normal?

YES >> INSPECTION END

NO >> Refer to [RF-31, "REAR SUNROOF SWITCH \(FRONT\) : Diagnosis Procedure"](#).

FRONT SUNROOF SWITCH : Diagnosis Procedure

INFOID:0000000011323114

1.CHECK FRONT SUNROOF SWITCH INPUT SIGNAL

1. Turn ignition switch OFF.
2. Disconnect front sunroof switch harness connector.
3. Turn ignition switch ON.
4. Check voltage between sunroof switch harness connector and ground.

(+)		(-)	Voltage (V)
Front sunroof switch			
Connector	Terminal	Ground	Battery voltage
R6	1		
	3		

Is the inspection result normal?

YES >> GO TO 3.

NO >> GO TO 2.

2.CHECK FRONT SUNROOF SWITCH CIRCUIT

1. Turn ignition switch OFF.
2. Disconnect front sunroof motor assembly harness connector.
3. Check continuity between front sunroof switch harness connector and front sunroof motor assembly harness connector.

Front sunroof switch		Front sunroof motor assembly		Continuity
Connector	Terminal	Connector	Terminal	
R6	1	R31	5	Existed
	3		10	

4. Check continuity between front sunroof switch harness connector and ground.

Front sunroof switch		Ground	Continuity
Connector	Terminal		
R6	1		Not existed
	3		

Is the inspection result normal?

YES >> Replace front sunroof motor assembly. Refer to [RF-53, "FRONT SUNROOF : Removal and Installation"](#).

NO >> Repair or replace harness.

3.CHECK GROUND CIRCUIT

1. Turn ignition switch OFF.
2. Check continuity between front sunroof switch harness connector and ground.

SUNROOF SWITCH

< DTC/CIRCUIT DIAGNOSIS >

Front sunroof switch		Ground	Continuity
Connector	Terminal		Existed
R6	2		

Is the inspection result normal?

- YES >> GO TO 4.
 NO >> Repair or replace harness or connector.

4.CHECK FRONT SUNROOF SWITCH

Check front sunroof switch.

Refer to [RF-32, "REAR SUNROOF SWITCH \(FRONT\) : Component Inspection"](#).

Is the inspection result normal?

- YES >> Check intermittent incident. Refer to [GI-42, "Intermittent Incident"](#).
 NO >> Replace sunroof switch (front). Refer to [RF-71, "FRONT : Removal and Installation"](#).

FRONT SUNROOF SWITCH : Component Inspection

INFOID:0000000011323115

SUNROOF SWITCH

1.CHECK FRONT SUNROOF SWITCH

1. Turn ignition switch OFF.
2. Disconnect front sunroof switch harness connector.
3. Check continuity front sunroof switch terminals.

Terminal	Condition	Continuity
1	Tilt down or slide open	Existed
	Other than the above	Not existed
3	Tilt up or slide close	Existed
	Other than the above	Not existed

Is the inspection result normal?

- YES >> INSPECTION END
 NO >> Replace sunroof switch (front). Refer to [RF-71, "FRONT : Removal and Installation"](#).

REAR SUNROOF SWITCH (FRONT)

REAR SUNROOF SWITCH (FRONT) : Component Function Check

INFOID:0000000011323116

1.CHECK FUNCTION

Check tilt up/down and slide open/close operations with rear sunroof switch (front).

Is the inspection result normal?

- YES >> INSPECTION END
 NO >> Refer to [RF-31, "REAR SUNROOF SWITCH \(FRONT\) : Diagnosis Procedure"](#).

REAR SUNROOF SWITCH (FRONT) : Diagnosis Procedure

INFOID:0000000011323117

1.CHECK REAR SUNROOF SWITCH (FRONT) INPUT SIGNAL

1. Turn ignition switch OFF.
2. Disconnect rear sunroof switch (front) and rear sunroof switch (rear) harness connector.
3. Turn ignition switch ON.
4. Check voltage between rear sunroof switch (front) harness connector and ground.

SUNROOF SWITCH

< DTC/CIRCUIT DIAGNOSIS >

(+)		(-)	Voltage (V)
Rear sunroof switch (front)			
Connector	Terminal	Ground	Battery voltage
R6	4		
	6		

Is the inspection result normal?

YES >> GO TO 3.

NO >> GO TO 2.

2. CHECK REAR SUNROOF SWITCH (FRONT) CIRCUIT

1. Turn ignition switch OFF.
2. Disconnect rear sunroof motor assembly harness connector.
3. Check continuity between rear sunroof switch (front) harness connector and rear sunroof motor assembly harness connector.

Rear sunroof switch (front)		Rear sunroof motor assembly		Continuity
Connector	Terminal	Connector	Terminal	
R6	4	R32	5	Existed
	6		10	

4. Check continuity between rear sunroof switch (front) harness connector and ground.

Rear sunroof switch (front)		Ground	Continuity
Connector	Terminal		
R6	4		Not existed
	6		

Is the inspection result normal?

YES >> Replace rear sunroof motor assembly. Refer to [RF-55, "REAR SUNROOF : Removal and Installation"](#).

NO >> Repair or replace harness.

3. CHECK GROUND CIRCUIT

1. Turn ignition switch OFF.
2. Check continuity between rear sunroof switch (front) harness connector and ground.

Rear sunroof switch (front)		Ground	Continuity
Connector	Terminal		
R6	5		Existed

Is the inspection result normal?

YES >> GO TO 4.

NO >> Repair or replace harness or connector.

4. CHECK REAR SUNROOF SWITCH (FRONT)

Check rear sunroof switch (front).

Refer to [RF-32, "REAR SUNROOF SWITCH \(FRONT\) : Component Inspection"](#).

Is the inspection result normal?

YES >> Check intermittent incident. Refer to [GI-42, "Intermittent Incident"](#).

NO >> Replace rear sunroof switch (front). Refer to [RF-71, "FRONT : Removal and Installation"](#).

REAR SUNROOF SWITCH (FRONT) : Component Inspection

INFOID:0000000011323118

SUNROOF SWITCH

1. CHECK REAR SUNROOF SWITCH (FRONT)

SUNROOF SWITCH

< DTC/CIRCUIT DIAGNOSIS >

1. Turn ignition switch OFF.
2. Disconnect rear sunroof switch (front) harness connector.
3. Check continuity rear sunroof switch (front) terminals.

Terminal		Condition	Continuity
4	5		
		Other than the above	Not existed
6		Tilt up or slide close	Existed
		Other than the above	Not existed

Is the inspection result normal?

YES >> INSPECTION END

NO >> Replace sunroof switch (front). Refer to [RF-71, "FRONT : Removal and Installation"](#).

REAR SUNROOF SWITCH (REAR)

REAR SUNROOF SWITCH (REAR) : Component Function Check

INFOID:000000011323119

1.CHECK FUNCTION

Check tilt up/down and slide open/close operations with rear sunroof switch (rear).

Is the inspection result normal?

YES >> INSPECTION END

NO >> Refer to [RF-33, "REAR SUNROOF SWITCH \(REAR\) : Diagnosis Procedure"](#).

REAR SUNROOF SWITCH (REAR) : Diagnosis Procedure

INFOID:000000011323120

1.CHECK REAR SUNROOF SWITCH (REAR) INPUT SIGNAL

1. Turn ignition switch OFF.
2. Disconnect rear sunroof switch (front) and rear sunroof switch (rear) harness connector.
3. Turn ignition switch ON.
4. Check voltage between rear sunroof switch (rear) harness connector and ground.

(+)		(-)	Voltage (V)
Rear sunroof switch (rear)			
Connector	Terminal	Ground	9.0 – 16.0
R112	1		
	3		

Is the inspection result normal?

YES >> GO TO 3.

NO >> GO TO 2.

2.CHECK REAR SUNROOF SWITCH (REAR) CIRCUIT

1. Turn ignition switch OFF.
2. Disconnect rear sunroof motor assembly harness connector.
3. Check continuity between rear sunroof switch (rear) harness connector and rear sunroof motor assembly harness connector.

Rear sunroof switch (rear)		Rear sunroof motor assembly		Continuity
Connector	Terminal	Connector	Terminal	
R112	1	R32	5	Existed
	3		10	

4. Check continuity between rear sunroof switch (rear) harness connector and ground.

SUNROOF SWITCH

< DTC/CIRCUIT DIAGNOSIS >

Rear sunroof switch (rear)		Ground	Continuity
Connector	Terminal		
R112	1		Not existed
	3		

Is the inspection result normal?

YES >> Replace rear sunroof motor assembly. Refer to [RF-55, "REAR SUNROOF : Removal and Installation"](#).

NO >> Repair or replace harness.

3.CHECK GROUND CIRCUIT

1. Turn ignition switch OFF.
2. Check continuity between rear sunroof switch (rear) harness connector and ground.

Rear sunroof switch (rear)		Ground	Continuity
Connector	Terminal		
R112	2		Existed

Is the inspection result normal?

YES >> GO TO 4.

NO >> Repair or replace harness or connector.

4.CHECK REAR SUNROOF SWITCH (REAR)

Check rear sunroof switch (rear).

Refer to [RF-32, "REAR SUNROOF SWITCH \(FRONT\) : Component Inspection"](#).

Is the inspection result normal?

YES >> Check intermittent incident. Refer to [GI-42, "Intermittent Incident"](#).

NO >> Replace rear sunroof switch (rear). Refer to [RF-72, "REAR : Removal and Installation"](#).

REAR SUNROOF SWITCH (REAR) : Component Inspection

INFOID:0000000011323121

SUNROOF SWITCH

1.CHECK REAR SUNROOF SWITCH (REAR)

1. Turn ignition switch OFF.
2. Disconnect rear sunroof switch (rear) harness connector.
3. Check continuity rear sunroof switch (rear) terminals.

Terminal		Rear sunroof switch (rear)	Condition	Continuity
1	2			Tilt down or slide open
		Other than the above		Not existed
3		Tilt up or slide close		Existed
		Other than the above		Not existed

Is the inspection result normal?

YES >> INSPECTION END

NO >> Replace rear sunroof switch (rear). Refer to [RF-72, "REAR : Removal and Installation"](#).

SUNROOF DOES NOT OPERATE PROPERLY

< SYMPTOM DIAGNOSIS >

SYMPTOM DIAGNOSIS

SUNROOF DOES NOT OPERATE PROPERLY FRONT SUNROOF

FRONT SUNROOF : Description

INFOID:0000000011323122

Sunroof does not operate normally.

- Glass lid does not slide or tilt.
- Judder occurs during sliding operation of glass lid.
- Sliding or tilting operation of glass lid is slow.

FRONT SUNROOF : Diagnosis Procedure

INFOID:0000000011323123

1.CHECK GLASS LID

Check the following items.

- Cracks, damage, or deformation of weather-strip.
- Sticking of weather-strip.
- Loose or missing glass lid mounting blot.
- Misalignment of glass lid.
Refer to [RF-48, "FRONT SUNROOF : Exploded View"](#).

Is the inspection result normal?

YES >> GO TO 2.

NO >> Repair or replace the malfunctioning parts.

2.CHECK SUNROOF FRAME ASSEMBLY

Check the following items.

- Damage, deformation or trapped foreign material of slide rail.
- Insufficient application of grease to sliding section of slide rail.
Refer to [RF-57, "FRONT SUNROOF : Exploded View"](#).

Is the inspection result normal?

YES >> GO TO 3.

NO >> Repair or replace the malfunctioning parts.

3.CHECK SUNSHADE

Check sunshade for damage, deformation, of interference with other parts.

Refer to [RF-63, "FRONT SUNROOF : Exploded View"](#).

Is the inspection result normal?

YES >> GO TO 4.

NO >> Repair or replace the malfunctioning parts.

4.CHECK BCM POWER SUPPLY AND GROUND CIRCUIT

Check BCM power supply and ground circuit. Refer to the following.

Refer to [BCS-91, "Diagnosis Procedure"](#).

Is the inspection result normal?

YES >> GO TO 5.

NO >> Repair or replace the malfunctioning parts.

5.CHECK SUNROOF MOTOR ASSEMBLY POWER SUPPLY AND GROUND CIRCUIT

Check sunroof motor assembly power supply and ground circuit.

Refer to [RF-22, "FRONT SUNROOF MOTOR ASSEMBLY : Diagnosis Procedure"](#).

Is the inspection result normal?

YES >> GO TO 6.

NO >> Repair or replace the malfunctioning parts.

6.CHECK SUNROOF SWITCH

Check sunroof switch.

Refer to [RF-30, "FRONT SUNROOF SWITCH : Component Function Check"](#).

A
B
C
D
E
F
G
H
I
J
L
M
N
O
P

RF

SUNROOF DOES NOT OPERATE PROPERLY

< SYMPTOM DIAGNOSIS >

Is the inspection result normal?

YES >> GO TO 7.

NO >> Repair or replace the malfunctioning parts.

7. CONFIRM THE OPERATION

Confirm the operation again.

Is the result normal?

YES >> Check intermittent incident. Refer to [GI-42. "Intermittent Incident"](#).

NO >> GO TO 1.

REAR SUNROOF

REAR SUNROOF : Description

INFOID:0000000011323124

Sunroof does not operate normally.

- Glass lid does not slide or tilt.
- Judder occurs during sliding operation of glass lid.
- Sliding or tilting operation of glass lid is slow.

REAR SUNROOF : Diagnosis Procedure

INFOID:0000000011323125

1. CHECK GLASS LID

Check the following items.

- Cracks, damage, or deformation of weather-strip.
- Sticking of weather-strip.
- Loose or missing glass lid mounting blot.
- Misalignment of glass lid.
Refer to [RF-50. "REAR SUNROOF : Exploded View"](#).

Is the inspection result normal?

YES >> GO TO 2.

NO >> Repair or replace the malfunctioning parts.

2. CHECK SUNROOF FRAME ASSEMBLY

Check the following items.

- Damage, deformation or trapped foreign material of slide rail.
- Insufficient application of grease to sliding section of slide rail.
Refer to [RF-59. "REAR SUNROOF : Exploded View"](#).

Is the inspection result normal?

YES >> GO TO 3.

NO >> Repair or replace the malfunctioning parts.

3. CHECK SUNSHADE

Check sunshade for damage, deformation, of interference with other parts.

Refer to [RF-65. "REAR SUNROOF : Exploded View"](#).

Is the inspection result normal?

YES >> GO TO 4.

NO >> Repair or replace the malfunctioning parts.

4. CHECK BCM POWER SUPPLY AND GROUND CIRCUIT

Check BCM power supply and ground circuit. Refer to the following.

Refer to [BCS-91. "Diagnosis Procedure"](#).

Is the inspection result normal?

YES >> GO TO 5.

NO >> Repair or replace the malfunctioning parts.

5. CHECK SUNROOF MOTOR ASSEMBLY POWER SUPPLY AND GROUND CIRCUIT

Check sunroof motor assembly power supply and ground circuit.

Refer to [RF-22. "REAR SUNROOF MOTOR ASSEMBLY : Diagnosis Procedure"](#).

Is the inspection result normal?

SUNROOF DOES NOT OPERATE PROPERLY

< SYMPTOM DIAGNOSIS >

YES >> GO TO 6.

NO >> Repair or replace the malfunctioning parts.

6.CHECK SUNROOF SWITCH

Check sunroof switch. Refer to the following.

• Rear sunroof switch (front): Refer to [RF-31. "REAR SUNROOF SWITCH \(FRONT\) : Component Function Check"](#).

• Rear sunroof switch (rear): Refer to [RF-33. "REAR SUNROOF SWITCH \(REAR\) : Component Function Check"](#).

Is the inspection result normal?

YES >> GO TO 7.

NO >> Repair or replace the malfunctioning parts.

7.CONFIRM THE OPERATION

Confirm the operation again.

Is the result normal?

YES >> Check intermittent incident. Refer to [GI-42. "Intermittent Incident"](#).

NO >> GO TO 1.

A
B
C
D
E
F
G
H
I
J
RF
L
M
N
O
P

AUTO OPERATION DOES NOT OPERATE

< SYMPTOM DIAGNOSIS >

AUTO OPERATION DOES NOT OPERATE FRONT SUNROOF

FRONT SUNROOF : Description

INFOID:000000011323126

Auto operation does not operate

- Auto operation of glass lid does not operate.
- Glass lid stops halfway.
- Anti-pinch function operates.

FRONT SUNROOF : Diagnosis Procedure

INFOID:000000011323127

1.CHECK GLASS LID

Check the following items.

- Cracks, damage, or deformation of weather-strip.
- Sticking of weather-strip.
- Loose or missing glass lid mounting blot.
- Misalignment of glass lid.
Refer to [RF-48. "FRONT SUNROOF : Exploded View"](#).

Is the inspection result normal?

YES >> GO TO 2.

NO >> Repair or replace the malfunctioning parts.

2.CHECK WIND DEFLECTOR

Check wind deflector for deformation and interference.

Refer to [RF-67. "FRONT SUNROOF : Exploded View"](#).

Is the inspection result normal?

YES >> GO TO 3.

NO >> Repair or replace the malfunctioning parts.

3.CHECK SUNROOF FRAME ASSEMBLY

Check the following items.

- Damage, deformation or trapped foreign material of slide rail.
- Insufficient application of grease to sliding section of slide rail.
Refer to [RF-57. "FRONT SUNROOF : Exploded View"](#).

Is the inspection result normal?

YES >> GO TO 4.

NO >> Repair or replace the malfunctioning parts.

4.PERFORM INITIALIZATION PROCEDURE

Perform initialization procedure.

Refer to [RF-21. "FRONT SUNROOF : Special Repair Requirement"](#).

Is the inspection result normal?

YES >> INSPECTION END

NO >> Replace sunroof motor assembly. Refer to [RF-53. "FRONT SUNROOF : Removal and Installation"](#).

REAR SUNROOF

REAR SUNROOF : Description

INFOID:000000011323128

Auto operation does not operate

- Auto operation of glass lid does not operate.
- Glass lid stops halfway.
- Anti-pinch function operates.

REAR SUNROOF : Diagnosis Procedure

INFOID:000000011323129

1.CHECK GLASS LID

AUTO OPERATION DOES NOT OPERATE

< SYMPTOM DIAGNOSIS >

Check the following items.

- Cracks, damage, or deformation of weather-strip.
- Sticking of weather-strip.
- Loose or missing glass lid mounting blot.
- Misalignment of glass lid.

A

B

C

Is the inspection result normal?

YES >> GO TO 2.

NO >> Repair or replace the malfunctioning parts.

2.CHECK WIND DEFLECTOR

Check wind deflector for deformation and interference.

Refer to [RF-69, "REAR SUNROOF : Exploded View"](#).

Is the inspection result normal?

YES >> GO TO 3.

NO >> Repair or replace the malfunctioning parts.

3.CHECK SUNROOF FRAME ASSEMBLY

Check the following items.

- Damage, deformation or trapped foreign material of slide rail.
- Insufficient application of grease to sliding section of slide rail.

Refer to [RF-59, "REAR SUNROOF : Exploded View"](#).

Is the inspection result normal?

YES >> GO TO 4.

NO >> Repair or replace the malfunctioning parts.

4.PERFORM INITIALIZATION PROCEDURE

Perform initialization procedure.

Refer to [RF-21, "FRONT SUNROOF : Special Repair Requirement"](#).

Is the inspection result normal?

YES >> INSPECTION END

NO >> Replace sunroof motor assembly. Refer to [RF-55, "REAR SUNROOF : Removal and Installation"](#).

D

E

F

G

H

I

J

RF

L

M

N

O

P

SUNROOF DOES NOT OPERATE ANTI-PINCH FUNCTION

< SYMPTOM DIAGNOSIS >

SUNROOF DOES NOT OPERATE ANTI-PINCH FUNCTION

Diagnosis Procedure

INFOID:000000011323130

1. PERFORM INITIALIZATION PROCEDURE

Perform initialization procedure.

Refer to [RF-21, "FRONT SUNROOF : Special Repair Requirement"](#).

Is the inspection result normal?

YES >> Inspection end.

NO >> Check intermittent incident. Refer to [GI-42, "Intermittent Incident"](#).

RETAINED POWER OPERATION DOES NOT OPERATE PROPERLY

< SYMPTOM DIAGNOSIS >

RETAINED POWER OPERATION DOES NOT OPERATE PROPERLY

Diagnosis Procedure

INFOID:000000011323131

1.CHECK DOOR SWITCH

Check door switch.

Refer to [DLK-241, "Component Function Check"](#).

Is the inspection result normal?

YES >> GO TO 2.

NO >> Repair or replace the malfunctioning parts.

2.CHECK SUNROOF MOTOR ASSEMBLY POWER SUPPLY AND GROUND

Check sunroof motor assembly power supply and ground circuit. Refer to the following.

- Front sunroof motor assembly: Refer to [RF-22, "FRONT SUNROOF MOTOR ASSEMBLY : Diagnosis Procedure"](#).
- Rear sunroof motor assembly: Refer to [RF-22, "REAR SUNROOF MOTOR ASSEMBLY : Diagnosis Procedure"](#).

Is the inspection result normal?

YES >> GO TO 3.

NO >> Repair or replace the malfunctioning parts.

3.REPLACE BCM

- Replace BCM. Refer to [BCS-98, "Removal and Installation"](#).
- Confirm the operation after replacement.

Is the result normal?

YES >> INSPECTION END

NO >> Check intermittent incident. Refer to [GI-42, "Intermittent Incident"](#).

A
B
C
D
E
F
G
H
I
J
RF
L
M
N
O
P

SQUEAK AND RATTLE TROUBLE DIAGNOSES

< SYMPTOM DIAGNOSIS >

SQUEAK AND RATTLE TROUBLE DIAGNOSES

Work Flow

INFOID:000000011323132

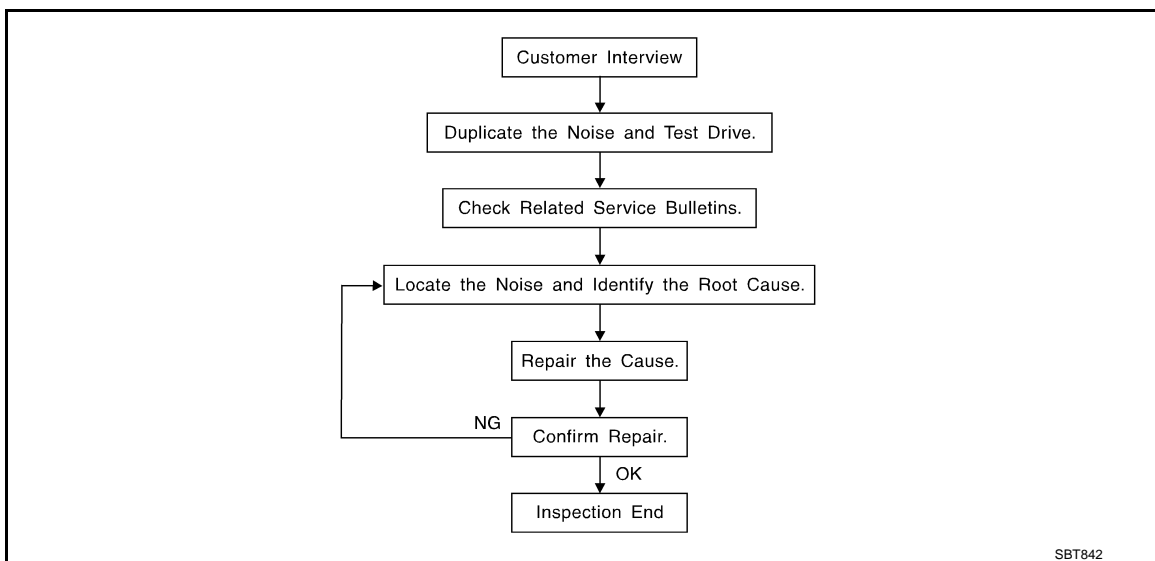

CUSTOMER INTERVIEW

Interview the customer if possible, to determine the conditions that exist when the noise occurs. Use the Diagnostic Worksheet during the interview to document the facts and conditions when the noise occurs and any customer comments. Refer to [RF-46, "Diagnostic Worksheet"](#). This information is necessary to duplicate the conditions that exist when the noise occurs.

- The customer may not be able to provide a detailed description or the location of the noise. Attempt to obtain all the facts and conditions that exist when the noise occurs (or does not occur).
- If there is more than one noise in the vehicle, perform a diagnosis and repair the noise that the customer is concerned about. This can be accomplished by performing a test drive with the customer.
- After identifying the type of noise, isolate the noise in terms of its characteristics. The noise characteristics are provided so that the customer, service adviser, and technician use the same language when describing the noise.
- Squeak – (Like tennis shoes on a clean floor)
Squeak characteristics include the light contact / fast movement / brought on by road conditions / hard surfaces = high-pitched noise / softer surfaces = low-pitched noises / edge to surface = chirping
- Creak – (Like walking on an old wooden floor)
Creak characteristics include firm contact / slow movement/twisting with a rotational movement / pitch dependent on materials / often brought on by activity.
- Rattle – (Like shaking a baby rattle)
Rattle characteristics include fast repeated contact / vibration or similar movement / loose parts/missing clip or fastener / incorrect clearance.
- Knock – (Like a knock on a door)
Knock characteristics include hollow sounds / sometimes repeating / often brought on by driver action.
- Tick – (Like a clock second hand)
Tick characteristics include gentle contacting of light materials / loose components / can be caused by driver action or road conditions.
- Thump – (Heavy, muffled knock noise)
Thump characteristics include softer knock / dull sounds often brought on by activity.
- Buzz – (Like a bumblebee)
Buzz characteristics include high frequency rattle / firm contact.
- Often the degree of acceptable noise level varies depending upon the person. A noise that a technician may judge as acceptable may be very irritating to a customer.
- Weather conditions, especially humidity and temperature, may have a great effect on noise level.

DUPLICATE THE NOISE AND TEST DRIVE

If possible, drive the vehicle with the customer until the noise is duplicated. Note any additional information on the Diagnostic Worksheet regarding the conditions or location of the noise. This information can be used to duplicate the same conditions when the repair is reconfirmed.

SQUEAK AND RATTLE TROUBLE DIAGNOSES

< SYMPTOM DIAGNOSIS >

If the noise can be duplicated easily during the test drive, to help identify the source of the noise, try to duplicate the noise with the vehicle stopped by doing one or all of the following items:

- 1) Close a door.
 - 2) Tap or push/pull around the area where the noise appears to be coming from.
 - 3) Rev the engine.
 - 4) Use a floor jack to recreate vehicle "twist".
 - 5) At idle, apply engine load (electrical load, half-clutch on M/T models, drive position on A/T models).
 - 6) Raise the vehicle on a hoist and hit a tire with a rubber hammer.
- Drive the vehicle and attempt to duplicate the conditions the customer states exist when the noise occurs.
 - If it is difficult to duplicate the noise, drive the vehicle slowly on an undulating or rough road to stress the vehicle body.

CHECK RELATED SERVICE BULLETINS

After verifying the customer concern or symptom, check ASIST for Technical Service Bulletins (TSBs) related to the concern or symptom.

If a TSB relates to the symptom, follow the procedure to repair the noise.

LOCATE THE NOISE AND IDENTIFY THE ROOT CAUSE

1. Narrow down the noise to a general area. To help pinpoint the source of the noise, use a listening tool (Chassis ear: J-39570, engine ear, and mechanics stethoscope).
2. Narrow down the noise to a more specific area and identify the cause of the noise by:
 - Removing the component(s) in the area that is / are suspected to be the cause of the noise. Do not use too much force when removing clips and fasteners, otherwise clips and fasteners can be broken or lost during the repair, resulting in the creation of new noise.
 - Tapping or pushing/pulling the component(s) that is / are suspected to be the cause of the noise. Do not tap or push/pull the component(s) with excessive force, otherwise the noise is eliminated only temporarily.
 - Feeling for a vibration by hand by touching the component(s) that is / are suspected to be the cause of the noise.
 - Placing a piece of paper between components that are suspected to be the cause of the noise.
 - Looking for loose components and contact marks.
Refer to [RF-44. "Inspection Procedure"](#).

REPAIR THE CAUSE

- If the cause is a loose component, tighten the component securely.
- If the cause is insufficient clearance between components:
 - Separate components by repositioning or loosening and retightening the components, if possible.
 - Insulate components with a suitable insulator such as urethane pads, foam blocks, felt cloth tape, or urethane tape. A NISSAN Squeak and Rattle Kit (J-50397) is available through the authorized NISSAN Parts Department.

CAUTION:

Never use excessive force as many components are constructed of plastic and may be damaged.

NOTE:

Always check with the Parts Department for the latest parts information.

The following materials are contained in the NISSAN Squeak and Rattle Kit (J-50397). Each item can be ordered separately as needed.

URETHANE PADS [1.5 mm (0.059 in) thick]

Insulates connectors, harness, etc.

- 76268-9E005: 100 × 135 mm (3.937 × 5.315 in)
- 76884-71L01: 60 × 85 mm (2.362 × 3.346 in)
- 76884-71L02: 15 × 25 mm (0.591 × 0.984 in)

INSULATOR (Foam blocks)

Insulates components from contact. Can be used to fill space behind a panel.

- 73982-9E000: 45 mm (1.772 in) thick, 50 × 50 mm (1.969 × 1.969 in)
- 73982-50Y00: 10 mm (0.394 in) thick, 50 × 50 mm (1.969 × 1.969 in)

INSULATOR (Light foam block)

80845-71L00: 30 mm (1.181 in) thick, 30 × 50 mm (1.181 × 1.969 in)

FELT CLOTHTAPE

Used to insulate where movement does not occur. Ideal for instrument panel applications.

- 68370-4B000: 15 × 25 mm (0.591 × 0.984 in) pad
- 68239-13E00: 5 mm (0.197 in) wide tape roll

SQUEAK AND RATTLE TROUBLE DIAGNOSES

< SYMPTOM DIAGNOSIS >

The following materials, not found in the kit, can also be used to repair squeaks and rattles.

UHMW (TEFLON) TAPE

Insulates where slight movement is present. Ideal for instrument panel applications.

SILICONE GREASE

Used in place of UHMW tape that is visible or does not fit. Only lasts a few months.

SILICONE SPRAY

Used when grease cannot be applied.

DUCT TAPE

Used to eliminate movement.

CONFIRM THE REPAIR

After repair is complete, test drive the vehicle to confirm that the cause of noise is repaired by test driving the vehicle. Operate the vehicle under the same conditions as when the noise originally occurred. Refer to the notes on the Diagnostic Worksheet.

Inspection Procedure

INFOID:000000011323133

Refer to Table of Contents for specific component removal and installation information.

INSTRUMENT PANEL

Most incidents are caused by contact and movement between:

1. The cluster lid A and instrument panel
2. Acrylic lens and combination meter housing
3. Instrument panel to front pillar garnish
4. Instrument panel to windshield
5. Instrument panel mounting pins
6. Wiring harnesses behind the combination meter
7. A/C defroster duct and duct joint

These incidents can usually be located by tapping or moving the components to duplicate the noise or by pressing on the components while driving to stop the noise. Most of these incidents can be repaired by applying felt cloth tape or silicon spray (in hard to reach areas). Urethane pads can be used to insulate wiring harness.

CAUTION:

Never use silicone spray to isolate a squeak or rattle. If the area is saturated with silicone, the recheck of repair becomes impossible.

CENTER CONSOLE

Components to check include:

1. Shifter assembly cover to finisher
2. A/C control unit and cluster lid C
3. Wiring harnesses behind audio and A/C control unit

The instrument panel repair and isolation procedures also apply to the center console.

DOORS

Check the following items:

1. Finisher and inner panel making a slapping noise
2. Inside handle escutcheon connection to door finisher
3. Wiring harnesses tapping
4. Door striker out of alignment causing a popping noise on starts and stops

Tapping, moving the components, or pressing on them while driving to duplicate the conditions can isolate many of these incidents. The areas can usually be insulated with felt cloth tape or insulator foam blocks from the NISSAN Squeak and Rattle Kit (J-50397) to repair the noise.

TRUNK

Trunk noises are often caused by a loose jack or loose items put into the trunk by the customer.

In addition check for the following items:

1. Trunk lid dumpers out of adjustment
2. Trunk lid striker out of adjustment

SQUEAK AND RATTLE TROUBLE DIAGNOSES

< SYMPTOM DIAGNOSIS >

3. Trunk lid torsion bars knocking together
4. A loose license plate or bracket

Most of these incidents can be repaired by adjusting, securing, or insulating the item(s) or component(s) causing the noise.

SUNROOF/HEADLINING

Noises in the sunroof / headlining area can often be traced to one of the following items:

1. Sunroof lid, rail, linkage, or seals making a rattle or light knocking noise
2. Sunvisor shaft shaking in the holder
3. Front or rear windshield touching headlining and squeaking

Again, pressing on the components to stop the noise while duplicating the conditions can isolate most of these incidents. Repairs usually consist of insulating with felt cloth tape.

SEATS

When isolating seat noise it is important to note the position the seat is in and the load placed on the seat when the noise occurs. These conditions should be duplicated when verifying and isolating the cause of the noise.

Causes of seat noise include:

1. Headrest rods and holder
2. A squeak between the seat pad cushion and frame
3. The rear seatback lock and bracket

These noises can be isolated by moving or pressing on the suspected components while duplicating the conditions under which the noise occurs. Most of these incidents can be repaired by repositioning the component or applying urethane tape to the contact area.

UNDERHOOD

Some interior noise may be caused by components under the hood or on the engine wall. The noise is then transmitted into the passenger compartment.

Causes of transmitted underhood noise include:

1. Any component mounted to the engine wall
2. Components that pass through the engine wall
3. Engine wall mounts and connectors
4. Loose radiator mounting pins
5. Hood bumpers out of adjustment
6. Hood striker out of adjustment

These noises can be difficult to isolate since they cannot be reached from the interior of the vehicle. The best method is to secure, move, or insulate one component at a time and test drive the vehicle. Also, engine RPM or load can be changed to isolate the noise. Repairs can usually be made by moving, adjusting, securing, or insulating the component causing the noise.

A
B
C
D
E
F
G
H
I
J
RF
L
M
N
O
P

SQUEAK AND RATTLE TROUBLE DIAGNOSES

< SYMPTOM DIAGNOSIS >

Diagnostic Worksheet

INFOID:000000011323134



SQUEAK & RATTLE DIAGNOSTIC WORKSHEET

Dear Nissan Customer:

We are concerned about your satisfaction with your Nissan vehicle. Repairing a squeak or rattle sometimes can be very difficult. To help us fix your Nissan right the first time, please take a moment to note the area of the vehicle where the squeak or rattle occurs and under what conditions. You may be asked to take a test drive with a service advisor or technician to ensure we confirm the noise you are hearing.

I. WHERE DOES THE NOISE COME FROM? (circle the area of the vehicle)

The illustrations are for reference only, and may not reflect the actual configuration of your vehicle.

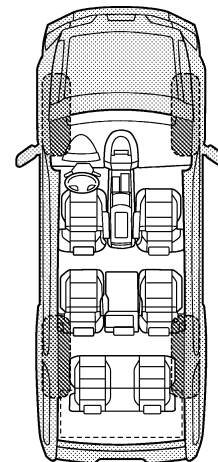
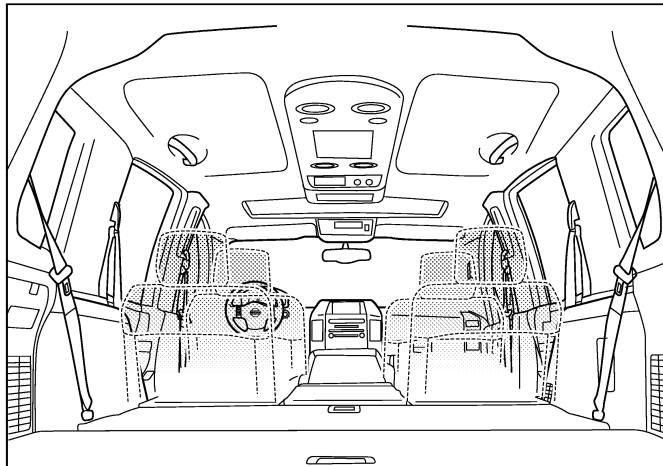
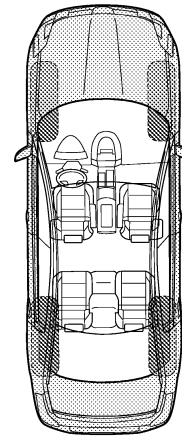
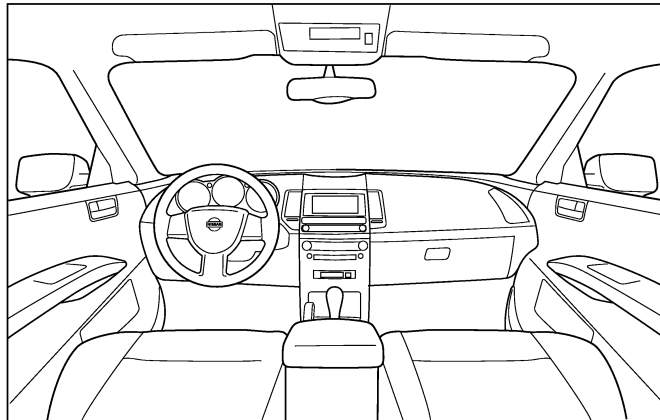

Continue to page 2 of the worksheet and briefly describe the location of the noise or rattle. In addition, please indicate the conditions which are present when the noise occurs.

PIIB8740E

SQUEAK AND RATTLE TROUBLE DIAGNOSES

< SYMPTOM DIAGNOSIS >

SQUEAK & RATTLE DIAGNOSTIC WORKSHEET - page 2

Briefly describe the location where the noise occurs:

II. WHEN DOES IT OCCUR? (please check the boxes that apply)

- | | |
|-------------------------------------------------------|--------------------------------------------------------|
| <input type="checkbox"/> anytime | <input type="checkbox"/> after sitting out in the rain |
| <input type="checkbox"/> 1st time in the morning | <input type="checkbox"/> when it is raining or wet |
| <input type="checkbox"/> only when it is cold outside | <input type="checkbox"/> dry or dusty conditions |
| <input type="checkbox"/> only when it is hot outside | <input type="checkbox"/> other: _____ |

III. WHEN DRIVING:

- through driveways
- over rough roads
- over speed bumps
- only about ____ mph
- on acceleration
- coming to a stop
- on turns: left, right or either (circle)
- with passengers or cargo
- other: _____
- after driving ____ miles or ____ minutes

IV. WHAT TYPE OF NOISE

- squeak (like tennis shoes on a clean floor)
- creak (like walking on an old wooden floor)
- rattle (like shaking a baby rattle)
- knock (like a knock at the door)
- tick (like a clock second hand)
- thump (heavy, muffled knock noise)
- buzz (like a bumble bee)

TO BE COMPLETED BY DEALERSHIP PERSONNEL

Test Drive Notes:

	YES	NO	Initials of person performing
Vehicle test driven with customer	<input type="checkbox"/>	<input type="checkbox"/>	_____
- Noise verified on test drive	<input type="checkbox"/>	<input type="checkbox"/>	_____
- Noise source located and repaired	<input type="checkbox"/>	<input type="checkbox"/>	_____
- Follow up test drive performed to confirm repair	<input type="checkbox"/>	<input type="checkbox"/>	_____

VIN: _____ Customer Name: _____
W.O.# _____ Date: _____

This form must be attached to Work Order

PIIB8742E

A
B
C
D
E
F
G
H
I
J
RF
L
M
N
O
P

GLASS LID

< REMOVAL AND INSTALLATION >

REMOVAL AND INSTALLATION

GLASS LID

FRONT SUNROOF

FRONT SUNROOF : Exploded View

INFOID:000000011323135

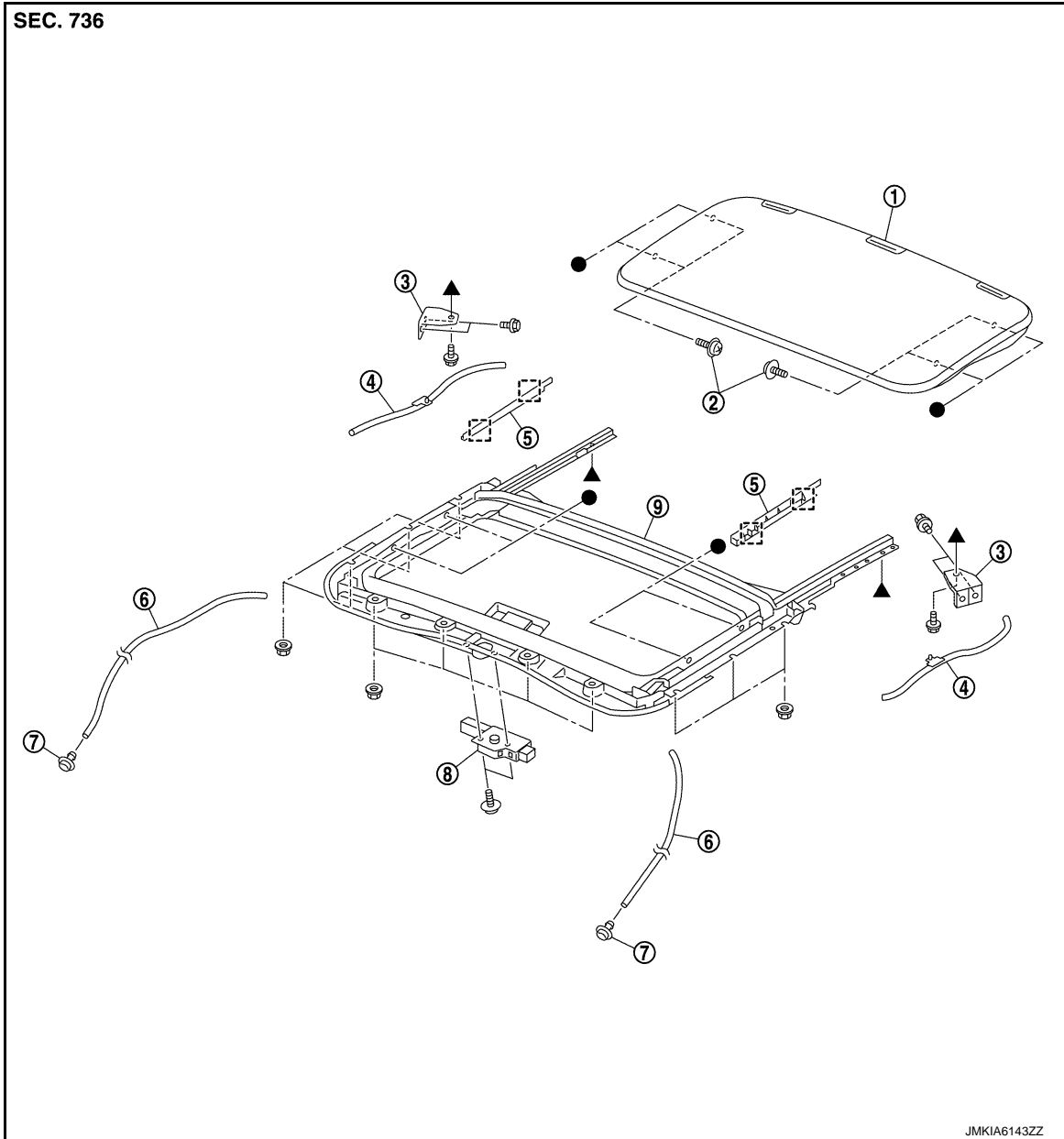

- | | | |
|--------------------------|---------------------------|--------------------------|
| 1. Glass lid | 2. TORX bolt | 3. Front sunroof bracket |
| 4. Center drain hose | 5. Side trim | 6. Front drain hose |
| 7. Front drain connector | 8. Sunroof motor assembly | 9. Sunroof unit assembly |

[] : Metal clip

●, ▲ : Indicates that the part is connected at points with same symbol in actual vehicle.

FRONT SUNROOF : Removal and Installation

INFOID:000000011323136

REMOVAL

GLASS LID

< REMOVAL AND INSTALLATION >

1. Tilt up glass lid and remove side trims (LH and RH).
2. Remove glass lid mounting TORX bolts, and then remove glass lid from vehicle.
3. Fully close glass lid.

INSTALLATION

Note the following items, and then install in the reverse order of removal.

NOTE:

After installation carry out fitting adjustment. Refer to [RF-49, "FRONT SUNROOF : Adjustment"](#).

FRONT SUNROOF : Adjustment

INFOID:000000011323137

Adjustment

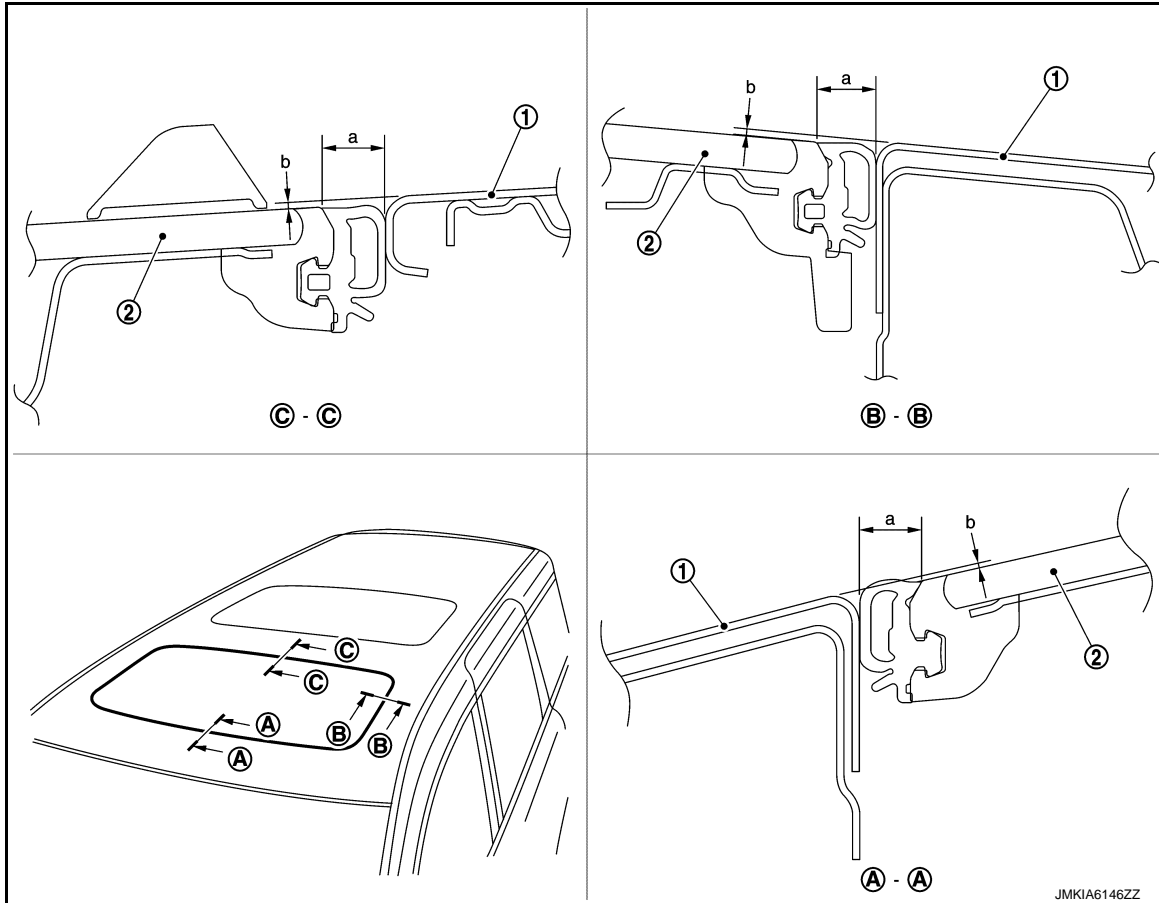

1. Roof panel

2. Glass lid

If the clearance and the surface height are out of specification, adjust them according to the procedures shown below.

1. Tilt up glass lid and remove side trims (LH and RH).
2. Loosen glass lid mounting TORX bolts.
3. Adjust the clearance of glass lid and roof panel according to the fitting standard dimension.

Portion	a (Clearance)	b (Surface height difference)
A - A	6.5 - 8.1 mm (0.256 - 0.319 in)	(-2.3) - (+0.7) mm [(-0.091) - (+0.028) in]
B - B	6.5 - 8.1 mm (0.256 - 0.319 in)	(-2.3) - (+0.7) mm [(-0.091) - (+0.028) in]
C - C	6.5 - 8.1 mm (0.256 - 0.319 in)	(-2.3) - (+0.7) mm [(-0.091) - (+0.028) in]

GLASS LID

< REMOVAL AND INSTALLATION >

- To prevent glass lid from moving after adjustment, first tighten the TORX bolts of front left, and then tighten the TORX bolts of rear right.
- Tilt glass lid up and down several times to check that it moves smoothly.

NOTE:

After adjustment the sunroof unit assembly, perform additional service. Refer to [RF-21, "FRONT SUNROOF : Description"](#).

REAR SUNROOF

REAR SUNROOF : Exploded View

INFOID:000000011323138

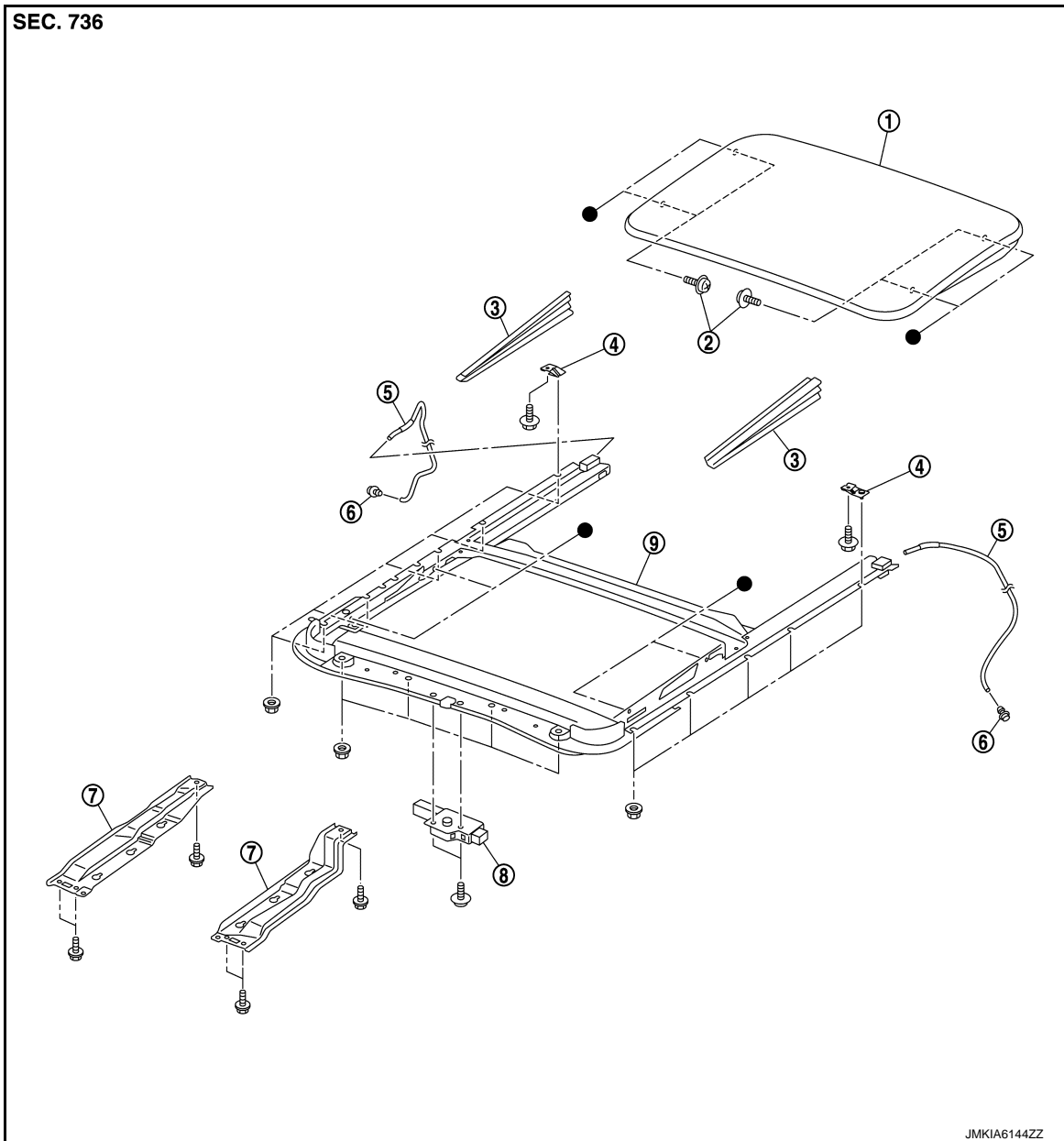

- | | | |
|-------------------------|---------------------------|--------------------------|
| 1. Glass lid | 2. TORX bolt | 3. Side trim |
| 4. Rear sunroof bracket | 5. Rear drain hose | 6. Rear drain connector |
| 7. Rear display bracket | 8. Sunroof motor assembly | 9. Sunroof unit assembly |

● : Indicates that the part is connected at points with same symbol in actual vehicle.

GLASS LID

< REMOVAL AND INSTALLATION >

REAR SUNROOF : Removal and Installation

INFOID:000000011323139

REMOVAL

1. Tilt up glass lid and remove side trims (LH and RH).
2. Remove glass lid mounting TORX bolts, and then remove glass lid from vehicle.
3. Fully close glass lid.

INSTALLATION

Note the following items, and then install in the reverse order of removal.

NOTE:

After installation carry out fitting adjustment. Refer to [RF-51, "REAR SUNROOF : Adjustment"](#).

REAR SUNROOF : Adjustment

INFOID:000000011323140

Adjustment

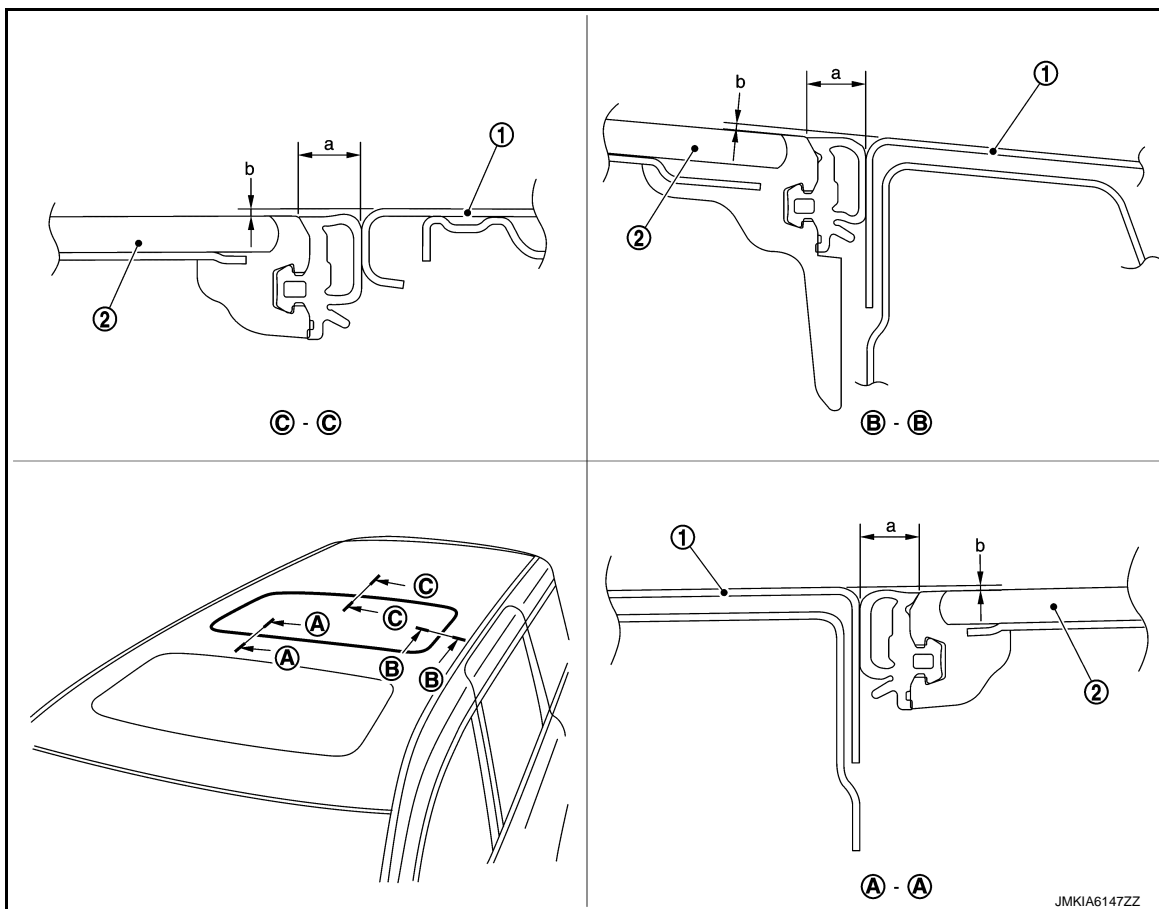

1. Roof panel

2. Glass lid

If the clearance and the surface height are out of specification, adjust them according to the procedures shown below.

1. Tilt up glass lid and remove side trims (LH and RH).
2. Loosen glass lid mounting TORX bolts.
3. Adjust the clearance of glass lid and roof panel according to the fitting standard dimension.

GLASS LID

< REMOVAL AND INSTALLATION >

Portion	a (Clearance)	b (Surface height difference)
A – A	6.5 – 8.1 mm (0.256 – 0.319 in)	(–2.3) – (+0.7) mm [(–0.091) – (+0.028) in]
B – B	6.5 – 8.1 mm (0.256 – 0.319 in)	(–2.3) – (+0.7) mm [(–0.091) – (+0.028) in]
C – C	6.5 – 8.1 mm (0.256 – 0.319 in)	(–2.3) – (+0.7) mm [(–0.091) – (+0.028) in]

- To prevent glass lid from moving after adjustment, first tighten the TORX bolts of front left, and then tighten the TORX bolts of rear right.
- Tilt glass lid up and down several times to check that it moves smoothly.

NOTE:

After adjustment the sunroof unit assembly, perform additional service. Refer to [RF-21, "REAR SUNROOF : Description"](#).

SUNROOF MOTOR ASSEMBLY

< REMOVAL AND INSTALLATION >

SUNROOF MOTOR ASSEMBLY

FRONT SUNROOF

FRONT SUNROOF : Exploded View

INFOID:000000011323141

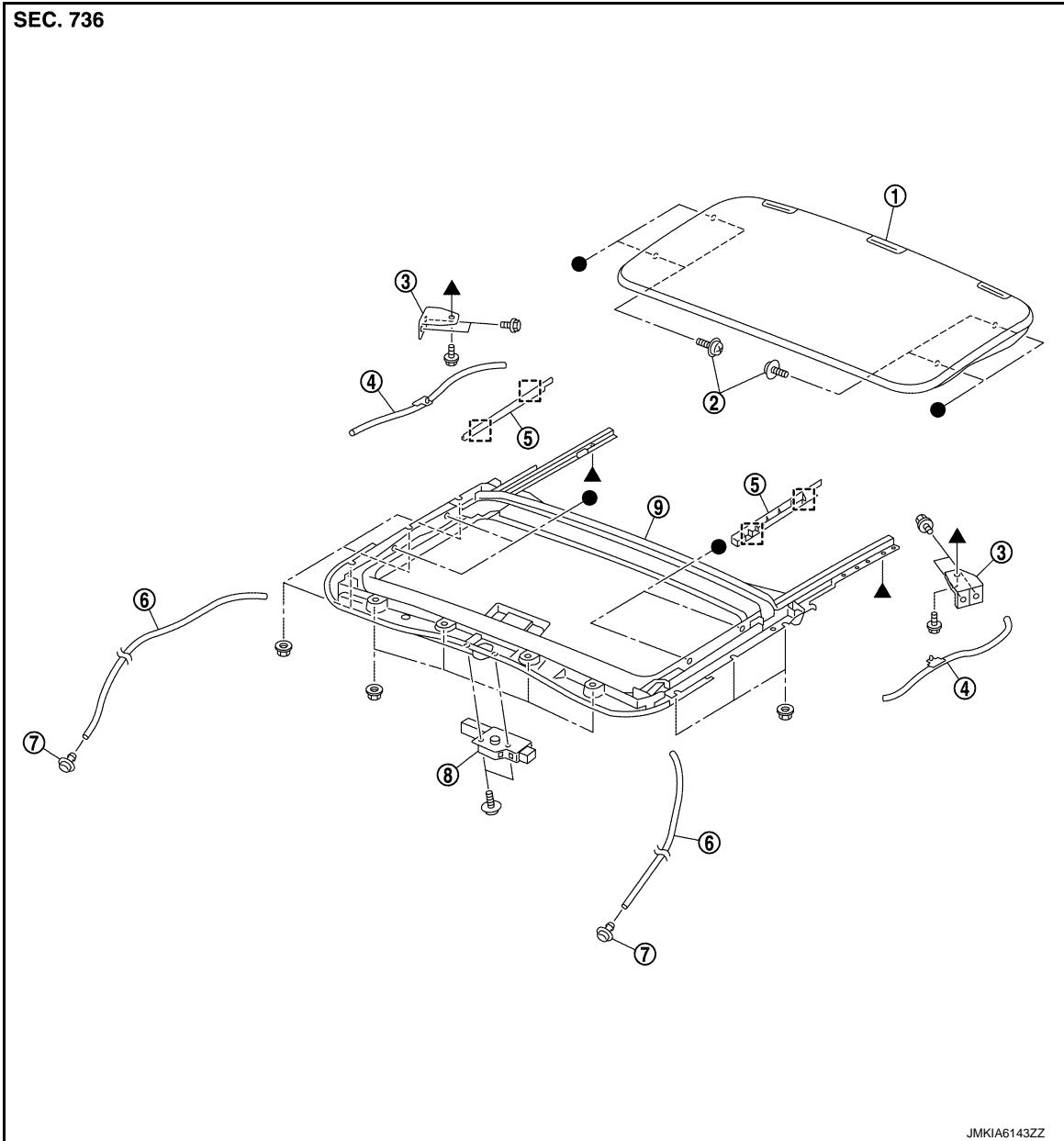

- | | | |
|--------------------------|---------------------------|--------------------------|
| 1. Glass lid | 2. TORX bolt | 3. Front sunroof bracket |
| 4. Center drain hose | 5. Side trim | 6. Front drain hose |
| 7. Front drain connector | 8. Sunroof motor assembly | 9. Sunroof unit assembly |

[] : Metal clip

●, ▲ : Indicates that the part is connected at points with same symbol in actual vehicle.

FRONT SUNROOF : Removal and Installation

INFOID:000000011323142

REMOVAL

CAUTION:

- Before removing sunroof motor, check that glass lid is fully closed.

SUNROOF MOTOR ASSEMBLY

< REMOVAL AND INSTALLATION >

- After removing sunroof motor, never attempt to rotate sunroof motor assembly as a single unit.

1. Fully close glass lid.
2. Remove map lamp assembly. Refer to [INL-67, "Removal and Installation"](#).
3. Remove sunroof motor assembly fixing screws (A), and then remove sunroof motor assembly.

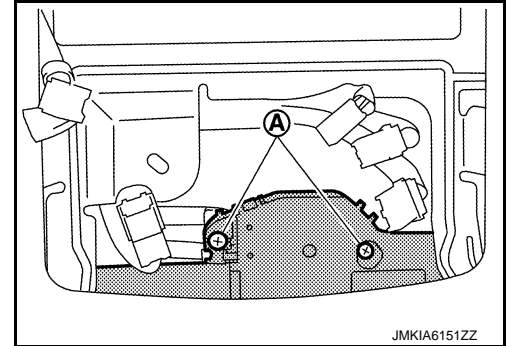

4. Disconnect harness connector from sunroof motor.

INSTALLATION

1. Move the sunroof motor assembly laterally by little so that the gear is completely engaged into the wire on the sunroof unit assembly and mounting surface becomes parallel. Then secure the sunroof motor assembly with screws.
2. Install map lamp assembly. Refer to [INL-67, "Removal and Installation"](#).

NOTE:

After installation sunroof motor, perform additional service. Refer to [RF-21, "FRONT SUNROOF : Description"](#).

REAR SUNROOF

SUNROOF MOTOR ASSEMBLY

< REMOVAL AND INSTALLATION >

REAR SUNROOF : Exploded View

INFOID:000000011323143

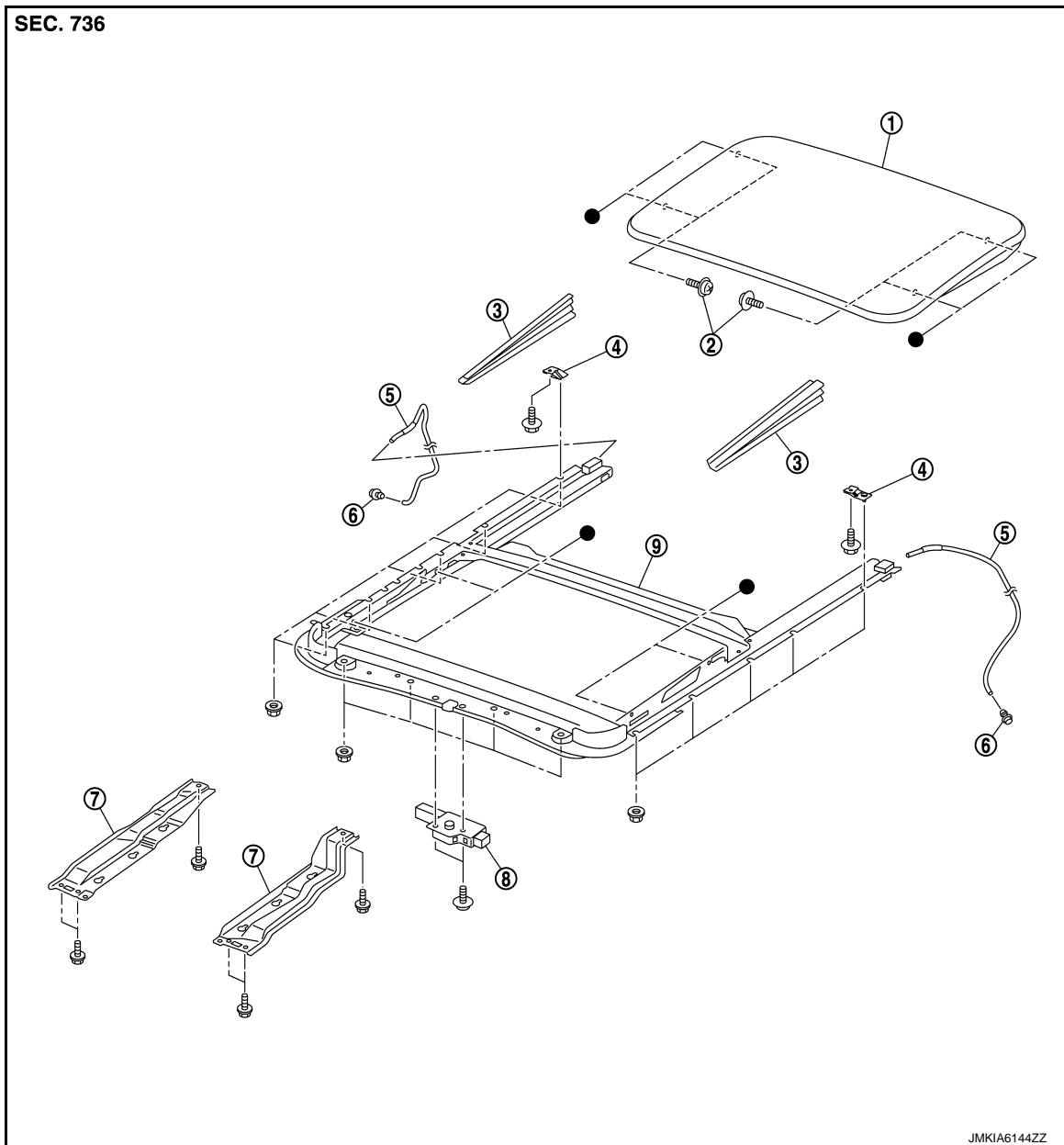

- | | | |
|-------------------------|---------------------------|--------------------------|
| 1. Glass lid | 2. TORX bolt | 3. Side trim |
| 4. Rear sunroof bracket | 5. Rear drain hose | 6. Rear drain connector |
| 7. Rear display bracket | 8. Sunroof motor assembly | 9. Sunroof unit assembly |

● : Indicates that the part is connected at points with same symbol in actual vehicle.

REAR SUNROOF : Removal and Installation

INFOID:000000011323144

REMOVAL

CAUTION:

- Before removing sunroof motor, check that glass lid is fully closed.
- After removing sunroof motor, never attempt to rotate sunroof motor assembly as a single unit.

1. Fully close glass lid.
2. Remove headlining. (without rear display) Refer to [INT-35. "Removal and Installation"](#).
3. Remove roof console. Refer to [INT-33. "Exploded View"](#).

SUNROOF MOTOR ASSEMBLY

< REMOVAL AND INSTALLATION >

4. Disconnect harness connector (A) from sunroof motor assembly.
5. Remove sunroof motor assembly fixing screws (B), and then remove sunroof motor assembly.

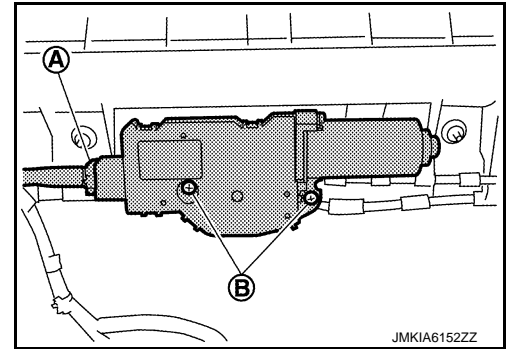

JMKIA6152ZZ

INSTALLATION

1. Move the sunroof motor assembly laterally by little so that the gear is completely engaged into the wire on the sunroof unit assembly and mounting surface becomes parallel. Then secure the sunroof motor assembly with screws.
2. Install headlining. (without rear display) Refer to [INT-35, "Removal and Installation"](#).
3. Install roof console. Refer to [INT-33, "Exploded View"](#).

NOTE:

After installation sunroof motor, perform additional service. Refer to [RF-21, "REAR SUNROOF : Description"](#).

SUNROOF UNIT ASSEMBLY

< REMOVAL AND INSTALLATION >

SUNROOF UNIT ASSEMBLY

FRONT SUNROOF

FRONT SUNROOF : Exploded View

INFOID:000000011323145

REMOVAL

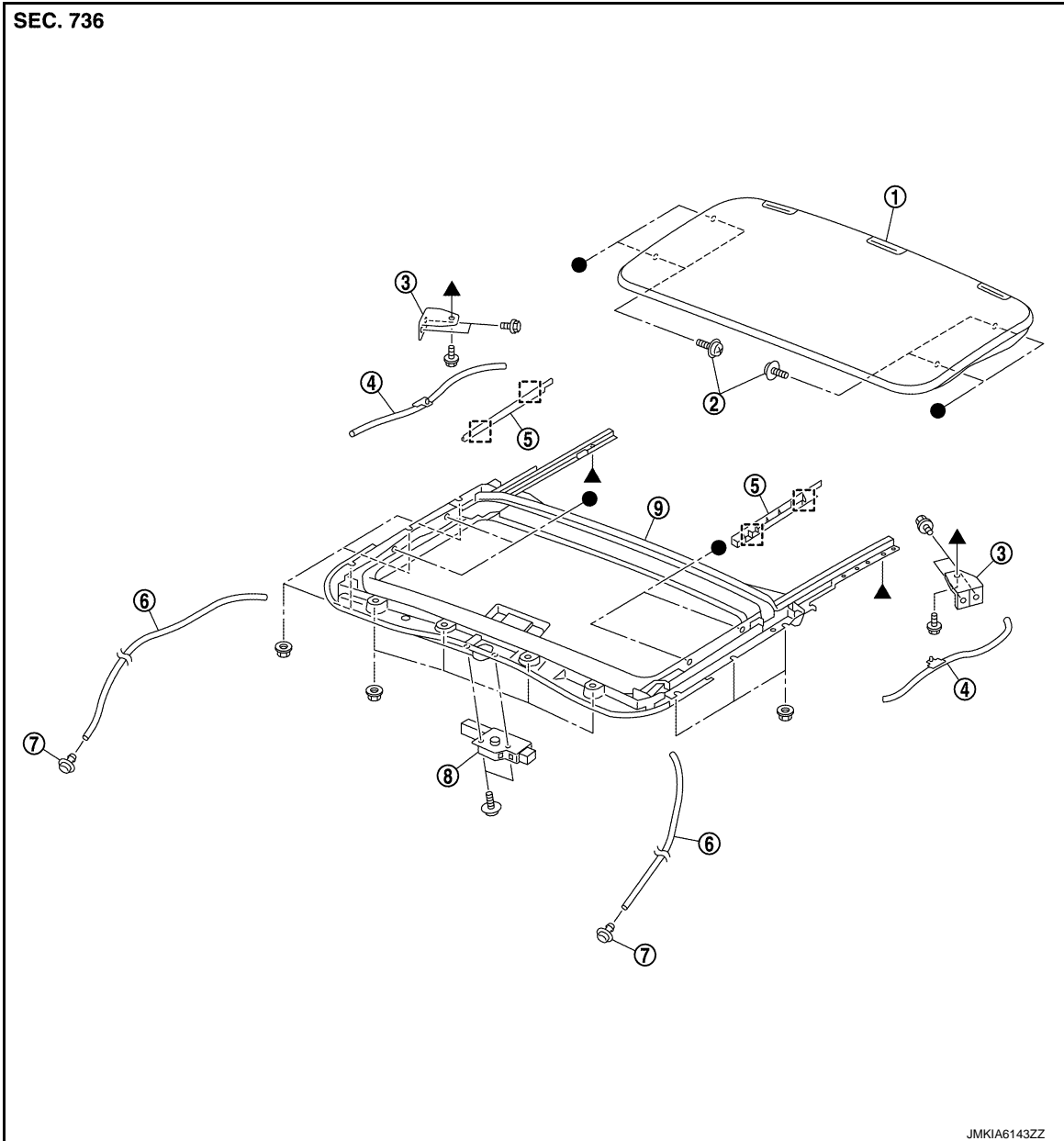

- | | | |
|--------------------------|---------------------------|--------------------------|
| 1. Glass lid | 2. TORX bolt | 3. Front sunroof bracket |
| 4. Center drain hose | 5. Side trim | 6. Front drain hose |
| 7. Front drain connector | 8. Sunroof motor assembly | 9. Sunroof unit assembly |

[] : Metal clip

●, ▲ : Indicates that the part is connected at points with same symbol in actual vehicle.

DISASSEMBLY

A
B
C
D
E
F
G
H
I
J
RF
L
M
N
O
P

SUNROOF UNIT ASSEMBLY

< REMOVAL AND INSTALLATION >

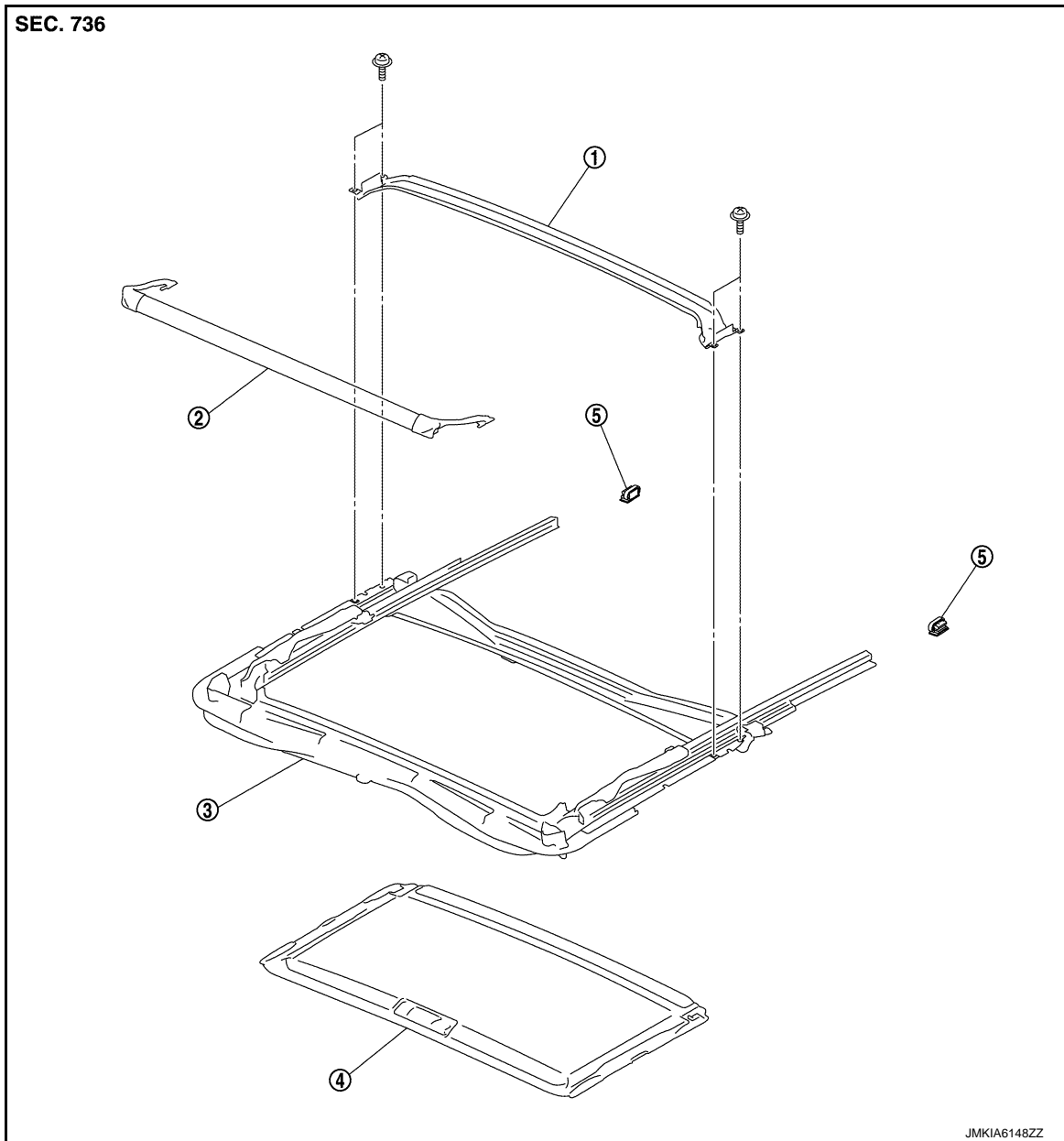

- | | | |
|------------------------|---------------------|---------------------------|
| 1. Rear drain assembly | 2. Wind deflector | 3. Sunroof frame assembly |
| 4. Sunshade | 5. Sunshade stopper | |

FRONT SUNROOF : Removal and Installation

INFOID:0000000011323146

REMOVAL

CAUTION:

- Always work with a helper.
- Fully close the glass lid assembly, before removal, then never operate sunroof motor assembly after removal.
- After removing sunroof motor assembly, never attempt to rotate sunroof motor assembly as a single unit.
- When remove/install sunroof unit, use cloths to protect the seats and trim from damage.
- After installing the sunroof unit and glass lid, perform the leak test and check that there is no malfunction.

1. Remove headlining. Refer to [INT-33, "Exploded View"](#).
2. Remove rear display. (with rear display) Refer to [AV-240, "Removal and Installation"](#).

SUNROOF UNIT ASSEMBLY

< REMOVAL AND INSTALLATION >

3. Remove rear sunroof unit assembly. Refer to [RF-61, "REAR SUNROOF : Removal and Installation"](#).
4. Remove rear display brackets.
5. Remove front sunroof glass lid. Refer to [RF-48, "FRONT SUNROOF : Removal and Installation"](#).
6. Disconnect front drain hoses.
7. Remove front sunroof brackets mounting bolts, and then remove front sunroof brackets.
8. Remove nuts from the front end and side rail, and then remove front sunroof unit assembly from roof panel.
9. Remove front sunroof unit assembly from roof panel.
10. Remove sunroof motor assembly.

INSTALLATION

1. Install front sunroof motor assembly.
2. Bring front sunroof unit into back door.
3. Temporarily tighten the mounting nuts to the side rail of front sunroof unit assembly.
4. Temporarily tighten the mounting nuts to the front end of front sunroof unit assembly.
5. Temporarily tighten the mounting bolts to the front sunroof brackets (LH and RH).
6. Tighten the front sunroof assembly mounting nuts diagonally in order.
7. Tighten front sunroof bracket bolts on the roof panel, and then tighten bolts on the side rail.
CAUTION:
Install front sunroof unit assembly evenly without any distortion on front sunroof unit assembly.
8. Connect front drain hoses.
9. Install rear display brackets.
10. Install rear sunroof unit assembly. Refer to [RF-61, "REAR SUNROOF : Removal and Installation"](#).
11. Install rear display. (with rear display) Refer to [AV-240, "Removal and Installation"](#).
12. Install headlining. Refer to [INT-35, "Removal and Installation"](#).
13. Install front sunroof glass lid. Refer to [RF-48, "FRONT SUNROOF : Removal and Installation"](#).

FRONT SUNROOF : Disassembly and Assembly

INFOID:000000011323147

DISASSEMBLY

1. Remove rear drain assembly from front sunroof unit assembly.
2. Remove sunshade. Refer to [RF-63, "FRONT SUNROOF : Removal and Installation"](#).
3. Remove wind deflector. Refer to [RF-67, "FRONT SUNROOF : Removal and Installation"](#).

ASSEMBLY

Assemble in the reverse order of disassembly.

REAR SUNROOF

REAR SUNROOF : Exploded View

INFOID:000000011323148

REMOVAL

SUNROOF UNIT ASSEMBLY

< REMOVAL AND INSTALLATION >

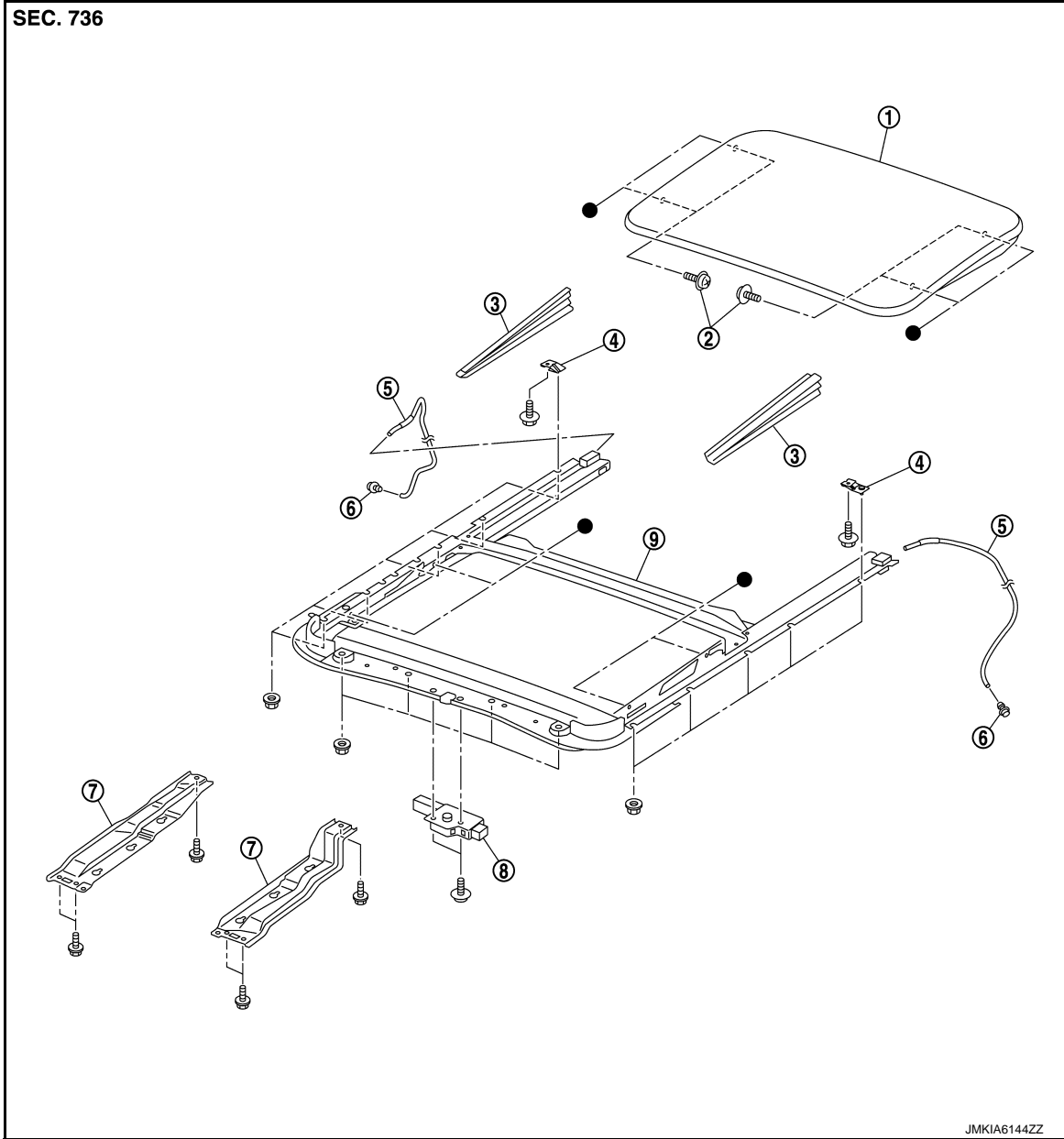

- | | | |
|-------------------------|---------------------------|--------------------------|
| 1. Glass lid | 2. TORX bolt | 3. Side trim |
| 4. Rear sunroof bracket | 5. Rear drain hose | 6. Rear drain connector |
| 7. Rear display bracket | 8. Sunroof motor assembly | 9. Sunroof unit assembly |

● : Indicates that the part is connected at points with same symbol in actual vehicle.

DISASSEMBLY

SUNROOF UNIT ASSEMBLY

< REMOVAL AND INSTALLATION >

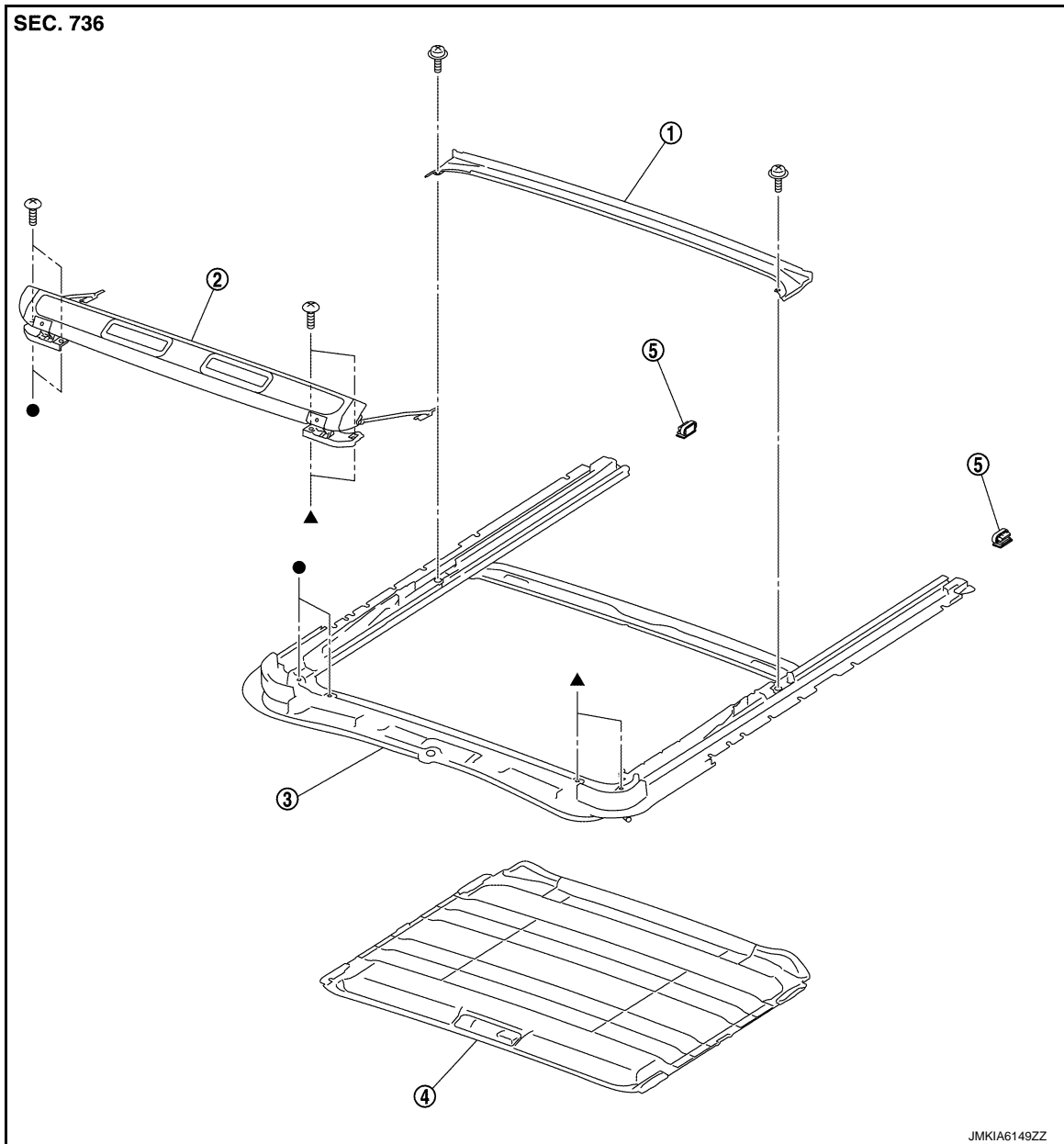

- | | | |
|------------------------|---------------------|---------------------------|
| 1. Rear drain assembly | 2. Wind deflector | 3. Sunroof frame assembly |
| 4. Sunshade | 5. Sunshade stopper | |

●, ▲ : Indicates that the part is connected at points with same symbol in actual vehicle.

REAR SUNROOF : Removal and Installation

INFOID:000000011323149

REMOVAL

CAUTION:

- Always work with a helper.
- Fully close the glass lid assembly, before removal, then never operate sunroof motor assembly after removal.
- After removing sunroof motor, never attempt to rotate sunroof motor assembly as a single unit.
- When remove/install sunroof unit, use cloths to protect the seats and trim from damage.

1. Remove headlining. Refer to [INT-35. "Removal and Installation"](#).
2. Remove glass lid. Refer to [RF-51. "REAR SUNROOF : Removal and Installation"](#).
3. Disconnect center drain hoses and rear drain hoses.
4. Remove rear sunroof brackets (LH and RH).

A
B
C
D
E
F
G
H
I
J

RF

L

M

N

O

P

SUNROOF UNIT ASSEMBLY

< REMOVAL AND INSTALLATION >

5. Remove nuts from the front end and side rail, and then remove rear sunroof unit assembly from roof panel.
6. Remove rear sunroof unit assembly through the back door while being careful not to damage the seats and trim.
7. Remove rear sunroof motor assembly.

INSTALLATION

1. Install rear sunroof motor assembly.
2. Bring rear sunroof unit into back door.
3. Temporarily tighten the mounting nuts to the side rail of rear sunroof unit assembly.
4. Temporarily tighten the mounting nuts to the front end of rear sunroof unit assembly.
5. Temporarily tighten the mounting bolts to the rear sunroof brackets (LH and RH).
6. Tighten the rear sunroof assembly mounting nuts diagonally in order.
7. Tighten rear sunroof bracket bolts on the roof panel, and then tighten bolts on the side rail.

CAUTION:

Install rear sunroof unit assembly evenly without any distortion on rear sunroof unit assembly.

8. Connect center drain hoses and rear drain hoses.
9. Install headlining. Refer to [INT-35, "Removal and Installation"](#).
10. Install glass lid. Refer to [RF-51, "REAR SUNROOF : Removal and Installation"](#).

REAR SUNROOF : Disassembly and Assembly

INFOID:000000011323150

DISASSEMBLY

1. Remove rear drain assembly from rear sunroof unit assembly.
2. Remove sunshade. Refer to [RF-65, "REAR SUNROOF : Removal and Installation"](#).
3. Remove wind deflector. Refer to [RF-69, "REAR SUNROOF : Removal and Installation"](#).

ASSEMBLY

Assemble in the reverse order of disassembly.

SUNSHADE

< REMOVAL AND INSTALLATION >

SUNSHADE FRONT SUNROOF

FRONT SUNROOF : Exploded View

INFOID:000000011323151

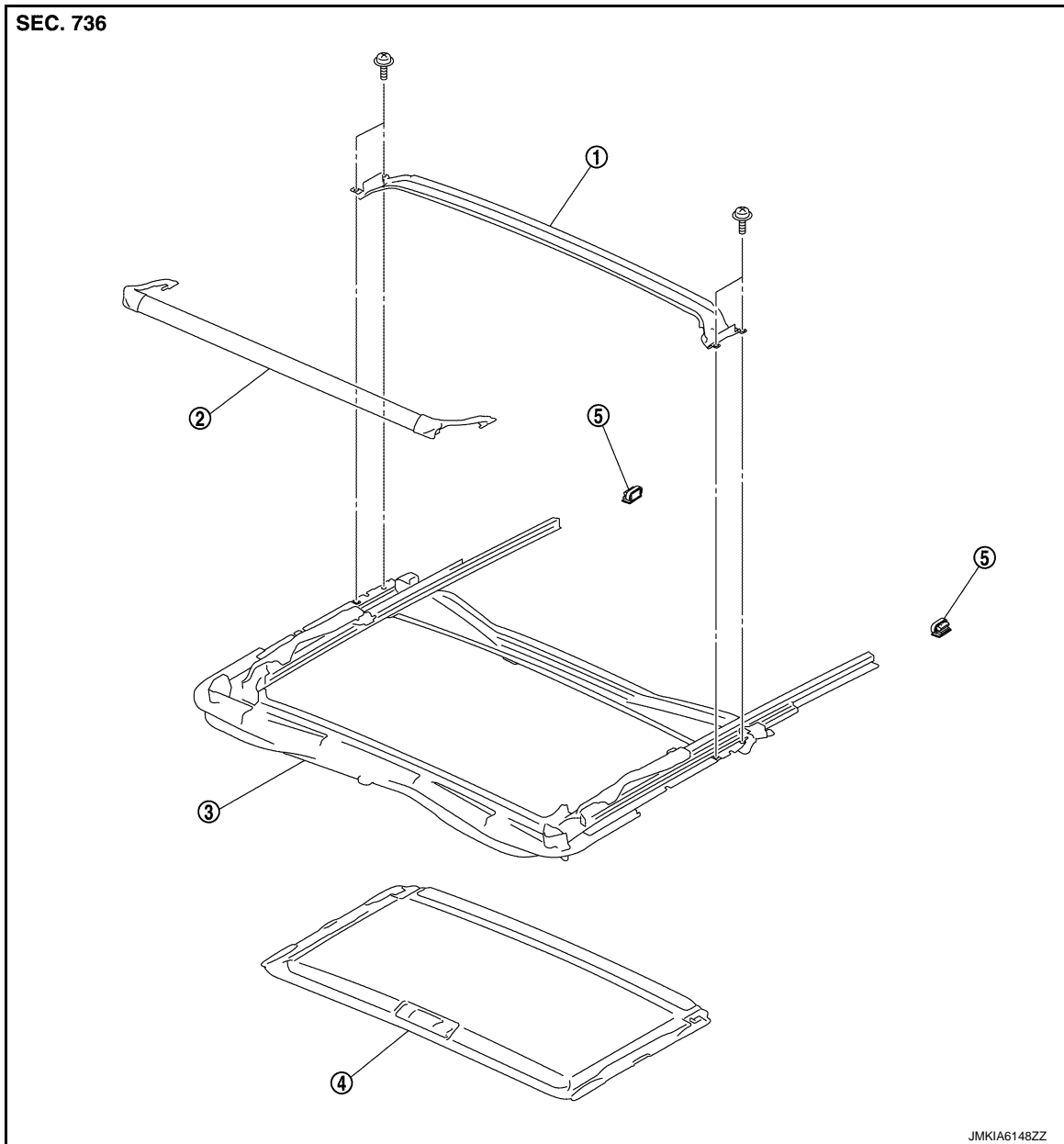

- | | | |
|------------------------|---------------------|---------------------------|
| 1. Rear drain assembly | 2. Wind deflector | 3. Sunroof frame assembly |
| 4. Sunshade | 5. Sunshade stopper | |

FRONT SUNROOF : Removal and Installation

INFOID:000000011323152

REMOVAL

1. Remove front sunroof unit assembly. Refer to [RF-58. "FRONT SUNROOF : Removal and Installation"](#).
2. Remove rear drain assembly.

SUNSHADE

< REMOVAL AND INSTALLATION >

3. Remove sunshade stopper (LH and RH) from the sunroof frame end.

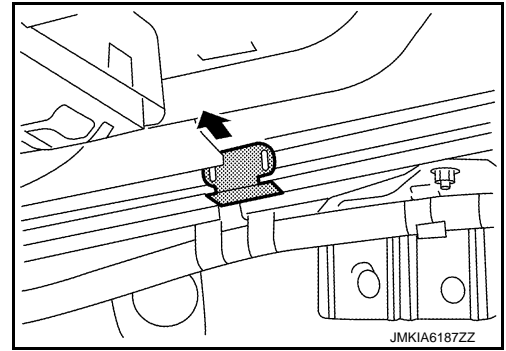

4. Remove sunshade from the rear end of sunroof frame.

INSTALLATION

Install in the reverse order of removal.

REAR SUNROOF

SUNSHADE

< REMOVAL AND INSTALLATION >

REAR SUNROOF : Exploded View

INFOID:000000011323153

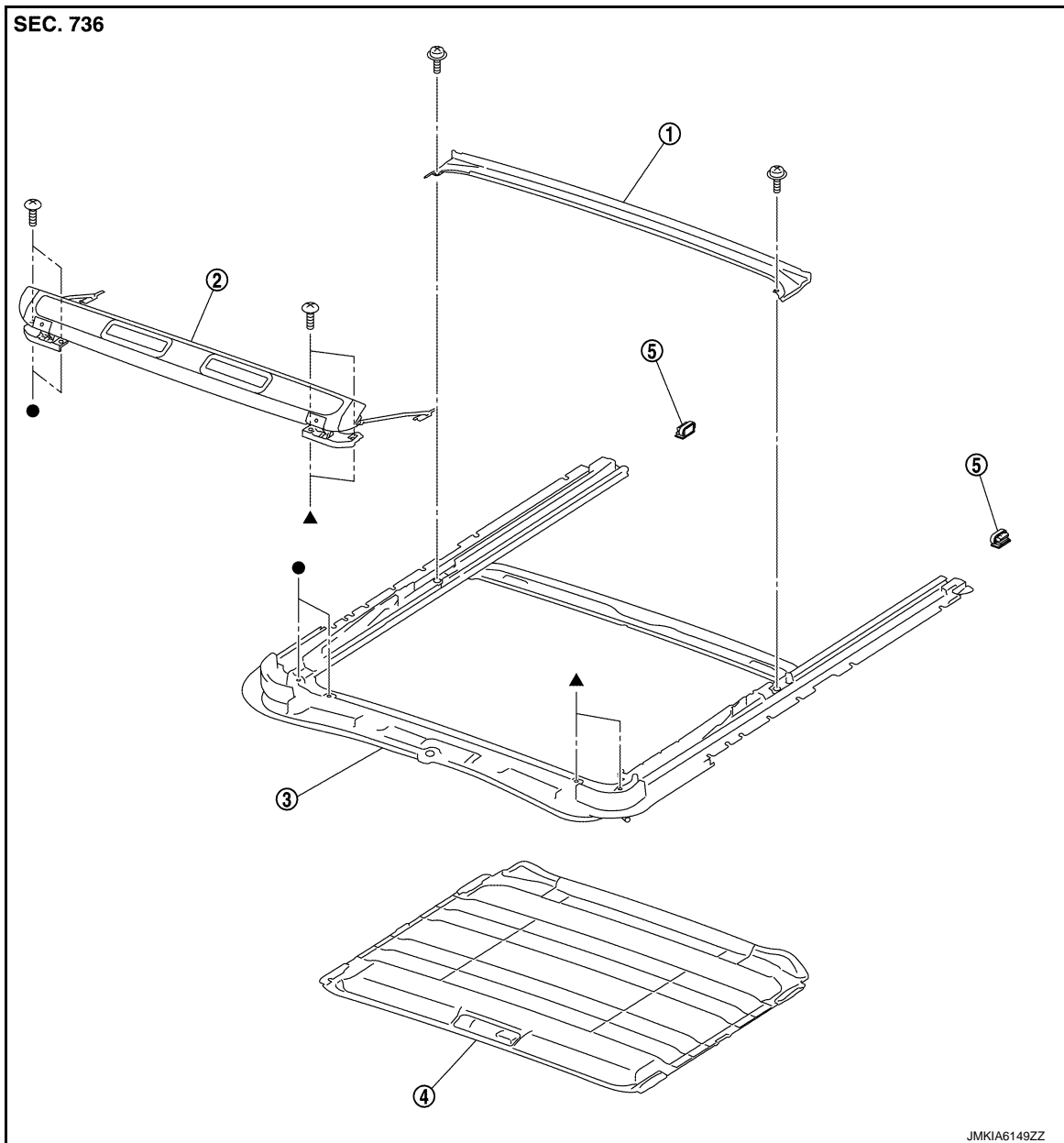

- | | | |
|------------------------|---------------------|---------------------------|
| 1. Rear drain assembly | 2. Wind deflector | 3. Sunroof frame assembly |
| 4. Sunshade | 5. Sunshade stopper | |

●, ▲ : Indicates that the part is connected at points with same symbol in actual vehicle.

REAR SUNROOF : Removal and Installation

INFOID:000000011323154

REMOVAL

1. Remove rear sunroof unit assembly. Refer to [RF-61, "REAR SUNROOF : Removal and Installation"](#).
2. Remove rear drain assembly.

SUNSHADE

< REMOVAL AND INSTALLATION >

3. Remove sunshade stopper (1) (LH and RH) from the sunroof frame end.

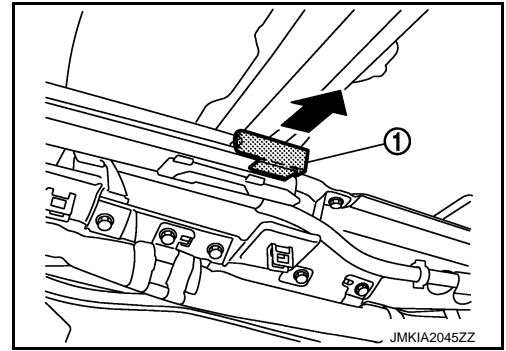

4. Remove sunshade from the rear end of sunroof frame.

INSTALLATION

Install in the reverse order of removal.

WIND DEFLECTOR

< REMOVAL AND INSTALLATION >

WIND DEFLECTOR FRONT SUNROOF

FRONT SUNROOF : Exploded View

INFOID:000000011323155

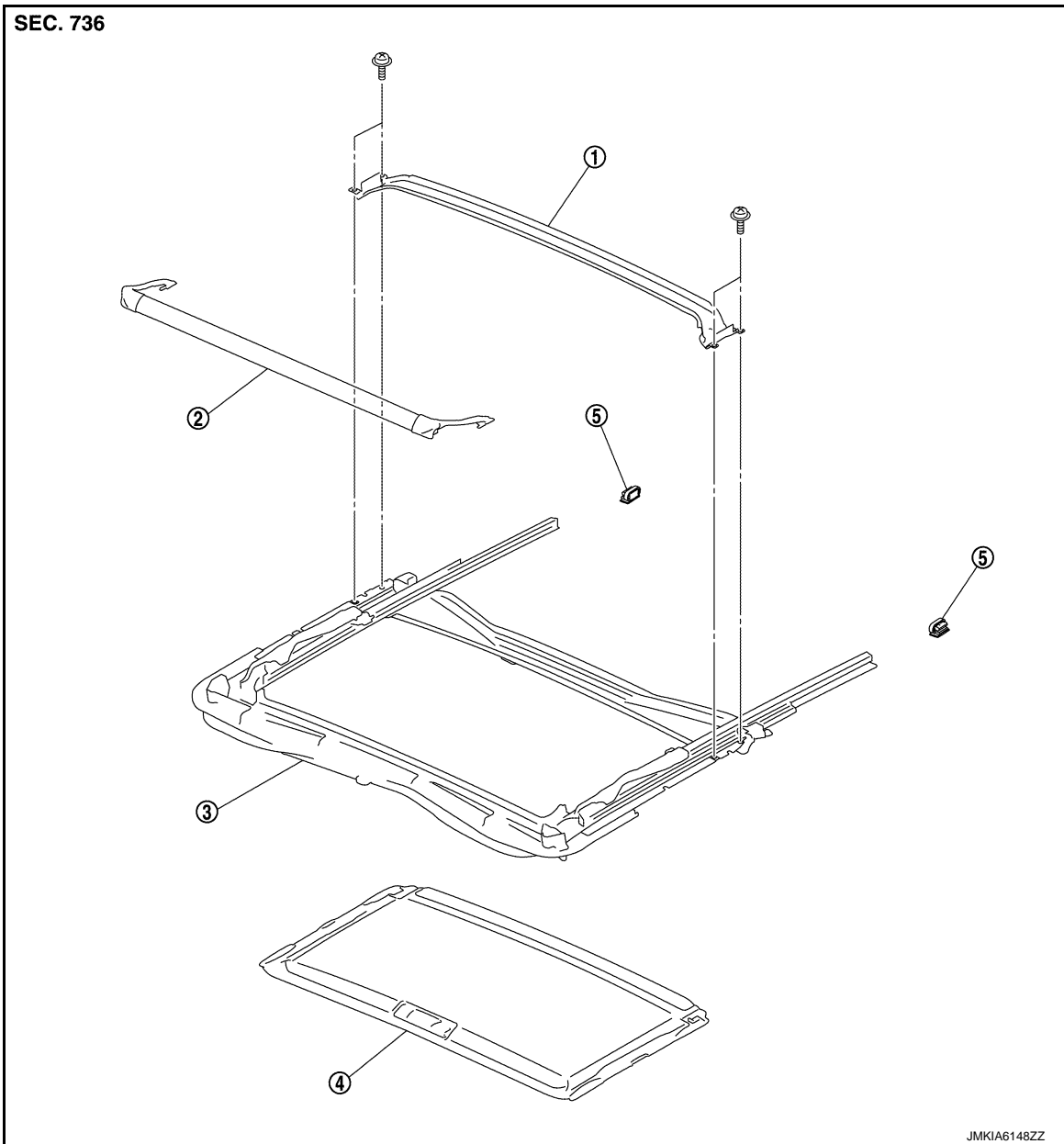

- | | | |
|------------------------|---------------------|---------------------------|
| 1. Rear drain assembly | 2. Wind deflector | 3. Sunroof frame assembly |
| 4. Sunshade | 5. Sunshade stopper | |

FRONT SUNROOF : Removal and Installation

INFOID:000000011323156

REMOAL

1. Open the glass lid to see the wind deflector installation point on the sun roof slide rail.

WIND DEFLECTOR

< REMOVAL AND INSTALLATION >

2. Remove wind deflector link base.

 : Pawl

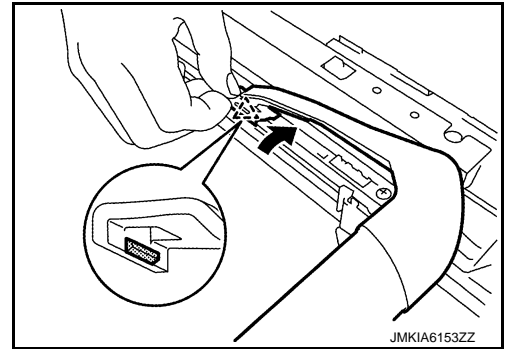

3. Rotate wind deflector, and then remove the spring from wind deflector spring base.

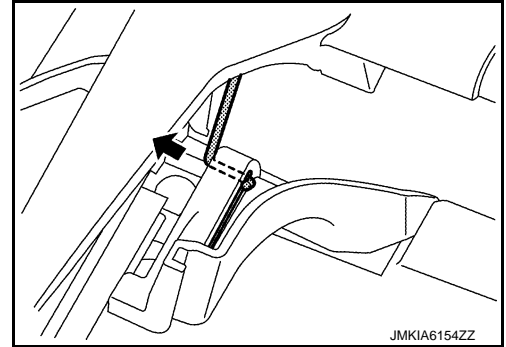

INSTALLATION

Install in the reverse order of removal.

REAR SUNROOF

WIND DEFLECTOR

< REMOVAL AND INSTALLATION >

REAR SUNROOF : Exploded View

INFOID:000000011323157

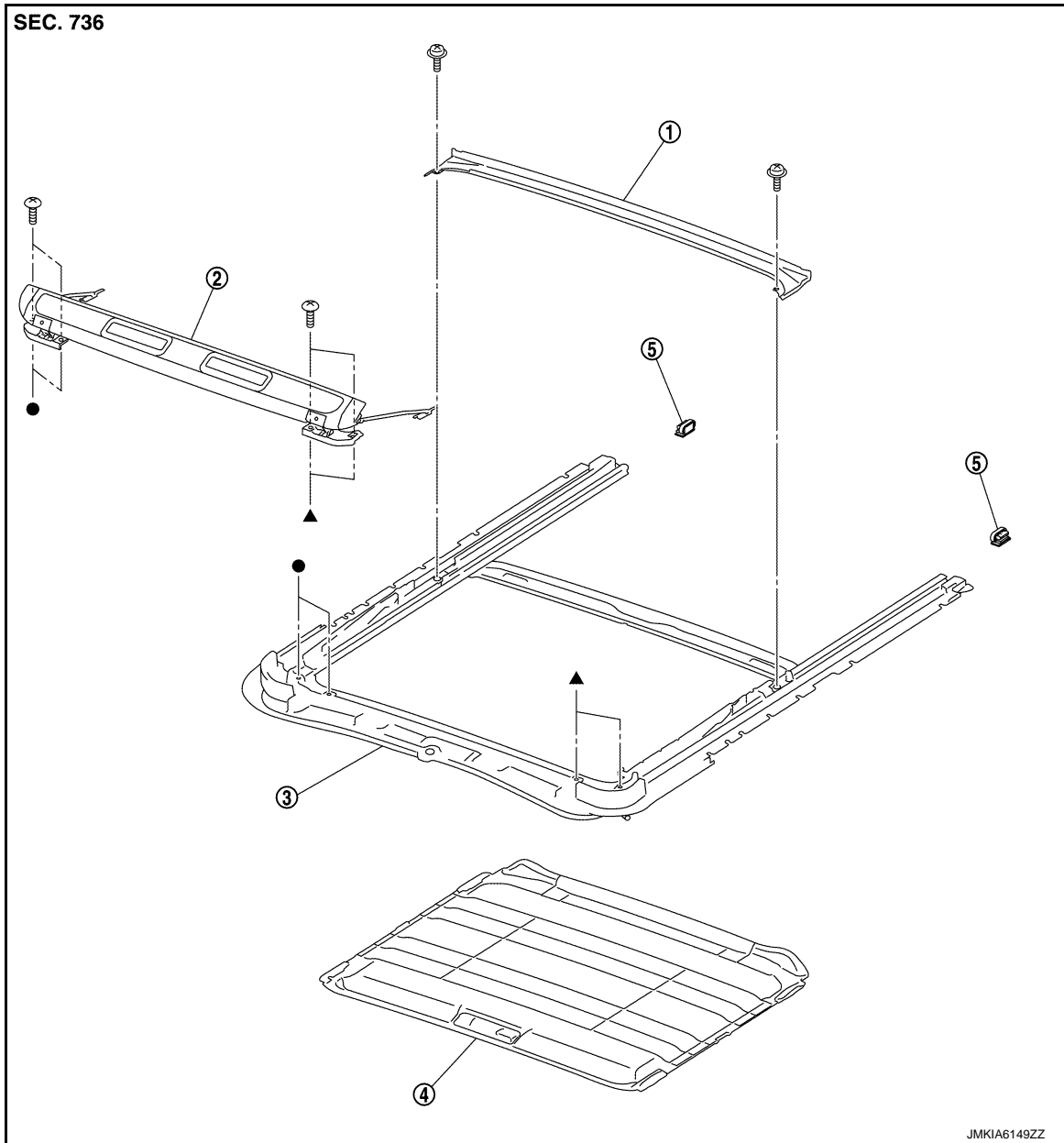

- | | | |
|------------------------|---------------------|---------------------------|
| 1. Rear drain assembly | 2. Wind deflector | 3. Sunroof frame assembly |
| 4. Sunshade | 5. Sunshade stopper | |

●, ▲ : Indicates that the part is connected at points with same symbol in actual vehicle.

REAR SUNROOF : Removal and Installation

INFOID:000000011323158

REMOVAL

1. Open the glass lid to see the wind deflector installation point on the sun roof slide rail.

WIND DEFLECTOR

< REMOVAL AND INSTALLATION >

2. Remove mounting pawl of wind deflector link using a removal tool (A) in numerical order as shown in the figure, and then remove wind deflector link.

 : Pawl

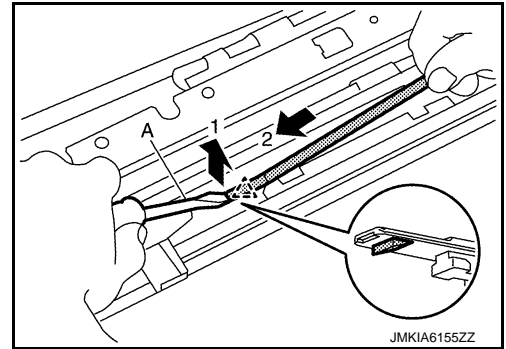

3. Remove hinge fixing screws (A), and then remove wind deflector.

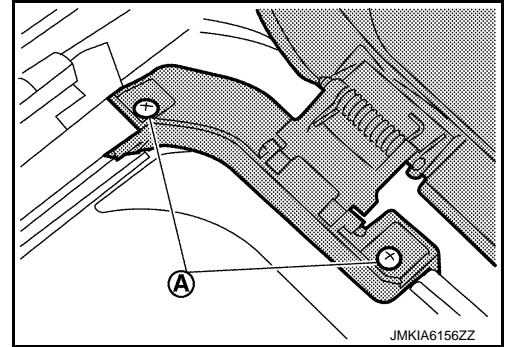

INSTALLATION

Install in the reverse order of removal.

SUNROOF SWITCH

< REMOVAL AND INSTALLATION >

SUNROOF SWITCH

FRONT

FRONT : Removal and Installation

INFOID:000000011323159

REMOVAL

1. Remove lens from map lamp assembly. Refer to [JNL-67. "Removal and Installation"](#).
2. Using a flat-bladed screw driver (A), disconnect pawls of map lamp assembly (2) from roof console assembly (1), and then remove map lamp assembly (2).

 : Pawl

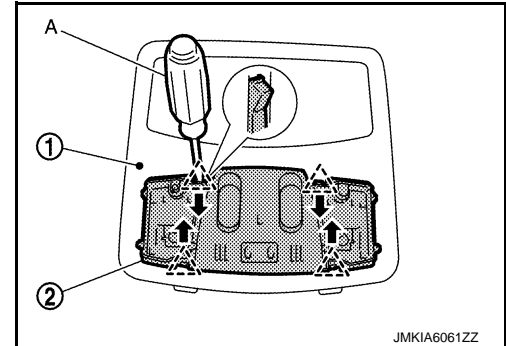

3. Remove harness connector.
4. Using a flat-bladed screw driver (A), disconnect pawls of switch finisher (2) from map lamp assembly (1), and then remove switch finisher (2).

 : Pawl

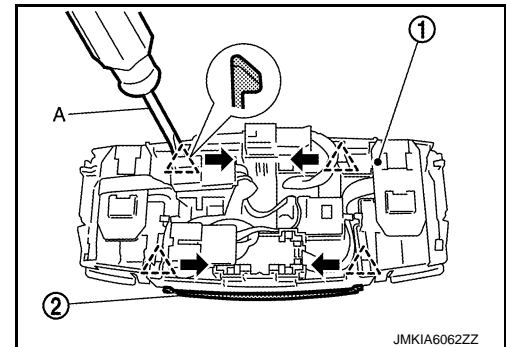

5. Disconnect pawls of connector (2) using a flat-bladed screw driver (A), and then remove connector (2) from map lamp assembly (1) in the direction indicated by an arrow as shown in the figure. Remove connector (3) in the same procedures.

 : Pawl

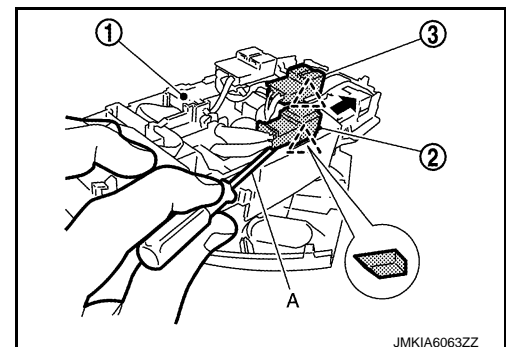

6. Disconnect pawls of sunroof switch (2) using a flat-bladed screw driver (A), and then remove sunroof switch (2) from map lamp assembly (1). Remove sunroof switch (3) in the same procedures.

 : Pawl

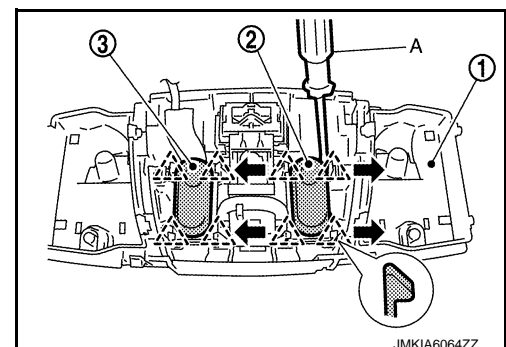

INSTALLATION

Install in the reverse order of removal.

SUNROOF SWITCH

< REMOVAL AND INSTALLATION >

REAR

REAR : Removal and Installation

INFOID:000000011323160

REMOVAL

1. Remove roof console assembly. Refer to [INT-35. "Removal and Installation"](#).
2. Remove torx bolts (A), and then remove sunroof switch (2) from roof console assembly (1).

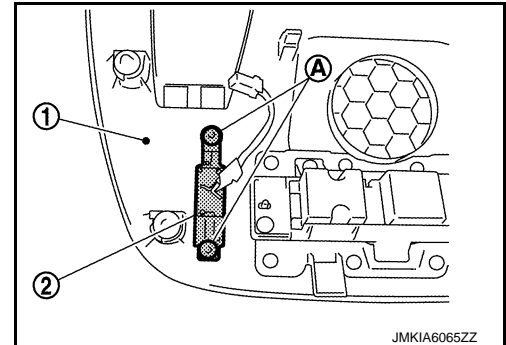

INSTALLATION

Installation in the reverse order of removal.