

SECTION **SB**
SEAT BELT

A
B
C
D
E
F
G
SB
I
J
K
L
M
N
O
P

CONTENTS

PRECAUTION	2	SEAT BELT RETRACTOR	11
PRECAUTIONS	2	SEAT BELT RETRACTOR : Removal and Instal-	
Precaution for Supplemental Restraint System		lation	12
(SRS) "AIR BAG" and "SEAT BELT PRE-TEN-		SEAT BELT RETRACTOR : Inspection	12
SIONER"	2	SEAT BELT BUCKLE	14
Precaution for Procedure without Cowl Top Cover.....	2	SEAT BELT BUCKLE : Removal and Installation....	14
Precautions For Xenon Headlamp Service	2	SEAT BELT BUCKLE : Inspection	14
Precautions for Removing Battery Terminal	3	SEAT BELT HOOK	14
Precaution for Seat Belt Service	3	SEAT BELT HOOK : Removal and Installation	14
REMOVAL AND INSTALLATION	5	THIRD SEAT BELT	16
FRONT SEAT BELT	5	Exploded View	16
Exploded View	5	SEAT BELT RETRACTOR	17
SEAT BELT RETRACTOR	6	SEAT BELT RETRACTOR : Removal and Instal-	
SEAT BELT RETRACTOR : Removal and Instal-		lation	17
lation	6	SEAT BELT RETRACTOR : Inspection	18
SEAT BELT RETRACTOR : Inspection	7	SEAT BELT BUCKLE	20
SEAT BELT BUCKLE	9	SEAT BELT BUCKLE : Removal and Installation....	20
SEAT BELT BUCKLE : Removal and Installation....	9	SEAT BELT BUCKLE : Inspection	20
SEAT BELT BUCKLE : Inspection	10	SEAT BELT HOOK	21
SECOND SEAT BELT	11	SEAT BELT HOOK : Removal and Installation	21
Exploded View	11		

PRECAUTIONS

< PRECAUTION >

PRECAUTION

PRECAUTIONS

Precaution for Supplemental Restraint System (SRS) "AIR BAG" and "SEAT BELT PRE-TENSIONER"

INFOID:000000011323290

The Supplemental Restraint System such as "AIR BAG" and "SEAT BELT PRE-TENSIONER", used along with a front seat belt, helps to reduce the risk or severity of injury to the driver and front passenger for certain types of collision. This system includes seat belt switch inputs and dual stage front air bag modules. The SRS system uses the seat belt switches to determine the front air bag deployment, and may only deploy one front air bag, depending on the severity of a collision and whether the front occupants are belted or unbelted. Information necessary to service the system safely is included in the "SRS AIR BAG" and "SEAT BELT" of this Service Manual.

WARNING:

Always observe the following items for preventing accidental activation.

- To avoid rendering the SRS inoperative, which could increase the risk of personal injury or death in the event of a collision that would result in air bag inflation, all maintenance must be performed by an authorized NISSAN/INFINITI dealer.
- Improper maintenance, including incorrect removal and installation of the SRS, can lead to personal injury caused by unintentional activation of the system. For removal of Spiral Cable and Air Bag Module, see "SRS AIR BAG".
- Never use electrical test equipment on any circuit related to the SRS unless instructed to in this Service Manual. SRS wiring harnesses can be identified by yellow and/or orange harnesses or harness connectors.

PRECAUTIONS WHEN USING POWER TOOLS (AIR OR ELECTRIC) AND HAMMERS

WARNING:

Always observe the following items for preventing accidental activation.

- When working near the Air Bag Diagnosis Sensor Unit or other Air Bag System sensors with the ignition ON or engine running, never use air or electric power tools or strike near the sensor(s) with a hammer. Heavy vibration could activate the sensor(s) and deploy the air bag(s), possibly causing serious injury.
- When using air or electric power tools or hammers, always switch the ignition OFF, disconnect the battery, and wait at least 3 minutes before performing any service.

Precaution for Procedure without Cowl Top Cover

INFOID:000000011552092

When performing the procedure after removing cowl top cover, cover the lower end of windshield with urethane, etc to prevent damage to windshield.

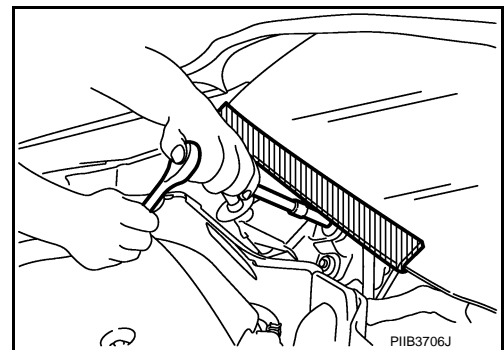

Precautions For Xenon Headlamp Service

INFOID:000000011552085

WARNING:

Comply with the following warnings to prevent any serious accident.

- Disconnect the battery cable (negative terminal) or the power supply fuse before installing, removing, or touching the xenon headlamp (bulb included). The xenon headlamp contains high-voltage generated parts.
- Never work with wet hands.
- Check the xenon headlamp ON-OFF status after assembling it to the vehicle. Never turn the xenon headlamp ON in other conditions. Connect the power supply to the vehicle-side connector.

PRECAUTIONS

< PRECAUTION >

(Turning it ON outside the lamp case may cause fire or visual impairments.)

- Never touch the bulb glass immediately after turning it OFF. It is extremely hot.

CAUTION:

Comply with the following cautions to prevent any error and malfunction.

- Install the xenon bulb securely. (Insufficient bulb socket installation may melt the bulb, the connector, the housing, etc. by high-voltage leakage or corona discharge.)
- Never perform HID circuit inspection with a tester.
- Never touch the xenon bulb glass with hands. Never put oil and grease on it.
- Dispose of the used xenon bulb after packing it in thick vinyl without breaking it.
- Never wipe out dirt and contamination with organic solvent (thinner, gasoline, etc.).

Precautions for Removing Battery Terminal

INFOID:000000011323291

- When removing the 12V battery terminal, turn OFF the ignition switch and wait at least 30 seconds.

NOTE:

ECU may be active for several tens of seconds after the ignition switch is turned OFF. If the battery terminal is removed before ECU stops, then a DTC detection error or ECU data corruption may occur.

- For vehicles with the 2-batteries, be sure to connect the main battery and the sub battery before turning ON the ignition switch.

NOTE:

If the ignition switch is turned ON with any one of the terminals of main battery and sub battery disconnected, then DTC may be detected.

- After installing the 12V battery, always check "Self Diagnosis Result" of all ECUs and erase DTC.

NOTE:

The removal of 12V battery may cause a DTC detection error.

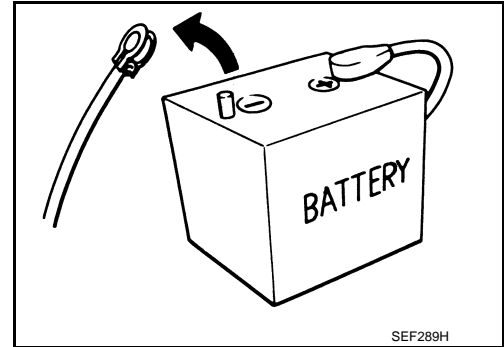

Precaution for Seat Belt Service

INFOID:000000011323292

CAUTION:

- Before removing the front seat belt pre-tensioner assembly, turn the ignition switch off, disconnect battery negative terminal and wait at least 3 minutes.
- Do not use electrical test equipment for front seat belt pre-tensioner connector.
- After replacing or reinstalling front seat belt pre-tensioner assembly, or reconnecting front seat belt pre-tensioner connector, check the system function. Refer to [SRC-15, "Description"](#).
- Do not use disassembled buckle or seat belt assembly.
- Replace anchor bolts if they are deformed or worn out.
- Never oil tongue and buckle.
- If any component of seat belt assembly is questionable, do not repair. Replace the entire seat belt assembly.
- If webbing is cut, frayed or damaged, replace seat belt assembly.
- When replacing seat belt assembly, use a genuine NISSAN seat belt assembly.

AFTER A COLLISION

WARNING:

Inspect all seat belt assemblies including retractors and attached hardware after any collision.

NISSAN recommends that all seat belt assemblies in use during a collision be replaced unless the collision was minor and the belts show no damage and continue to operate properly. Failure to do so could result in serious personal injury in an accident. Seat belt assemblies not in use during a collision should also be replaced if either damage or improper operation is noted. Seat belt pre-tensioners should be replaced even if the seat belts are not in use during a frontal collision in which the air bags are deployed.

Replace any seat belt assembly (including anchor bolts) if:

- The seat belt was in use at the time of a collision (except for minor collisions and the belts, retractors and buckles show no damage and continue to operate properly).
- The seat belt was damaged in an accident (i.e. torn webbing, bent retractor or guide).
- The seat belt attaching point was damaged in an accident. Inspect the seat belt attaching area for damage or distortion and repair as necessary before installing a new seat belt assembly.
- Anchor bolts are deformed or worn out.

PRECAUTIONS

< PRECAUTION >

- The front seat belt pre-tensioner should be replaced even if the seat belts are not in use during the collision in which the air bags are deployed.

FRONT SEAT BELT

< REMOVAL AND INSTALLATION >

REMOVAL AND INSTALLATION

FRONT SEAT BELT

Exploded View

INFOID:000000011323293

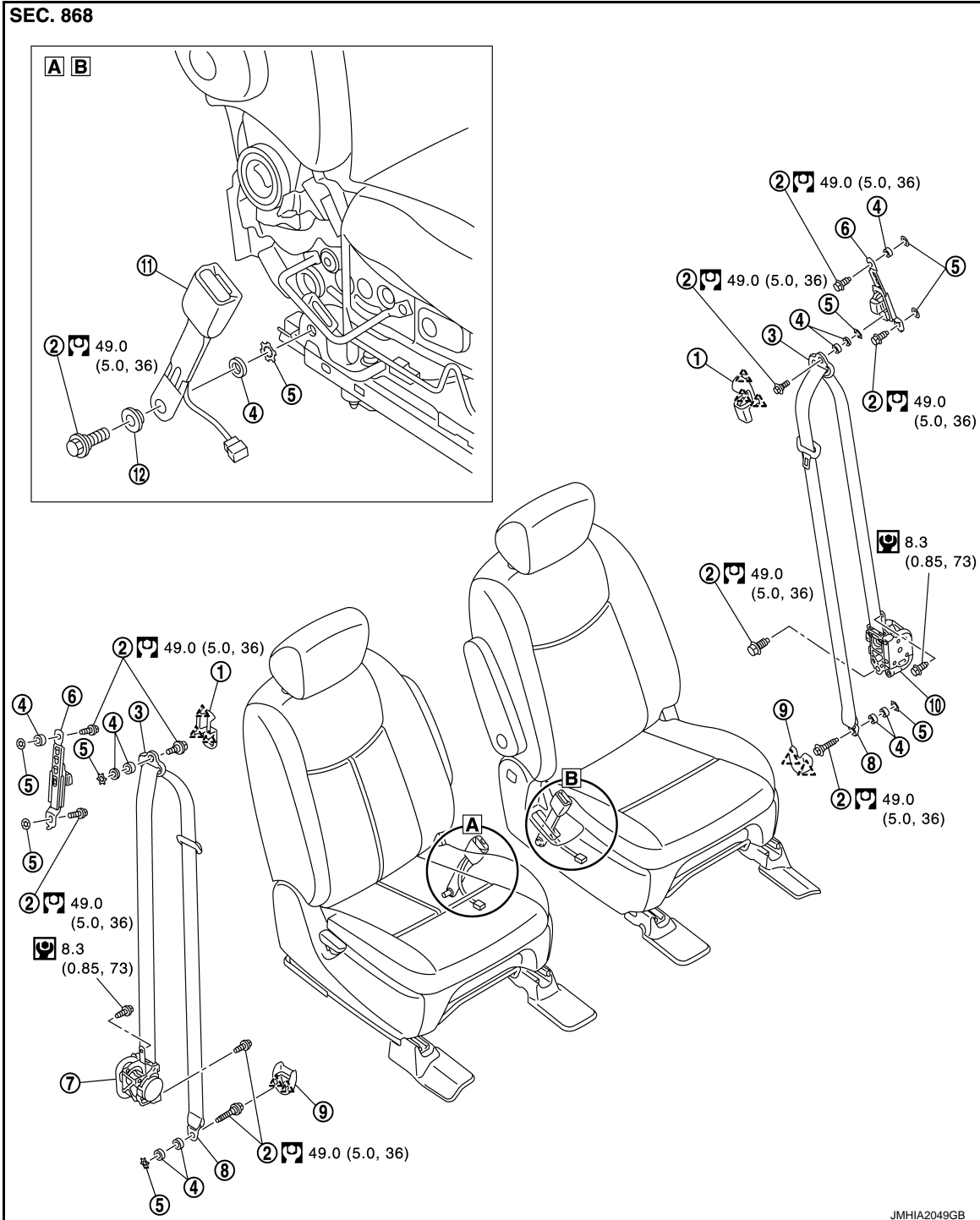

- | | | |
|---|---------------------|-----------------------|
| 1. Adjuster cover | 2. Anchor bolt | 3. Shoulder anchor |
| 4. Spacer | 5. Retaining washer | 6. Seat belt adjuster |
| 7. Seat belt pre-tensioner retractor (Passenger side) | 8. Outer anchor | 9. Outer anchor cover |

FRONT SEAT BELT

< REMOVAL AND INSTALLATION >

10. Seat belt pre-tensioner retractor
(Driver side)

11. Seat belt buckle

12. Wave washer

 : Pawl

 : N·m (kg-m, in-lb)

 : N·m (kg-m, ft-lb)

SEAT BELT RETRACTOR

SEAT BELT RETRACTOR : Removal and Installation

INFOID:000000011323294

REMOVAL

WARNING:

Before servicing, turn ignition switch OFF, disconnect battery negative terminal and wait 3 minutes or more.

1. Remove shoulder anchor.
 - a. Slide front seat to the frontmost position.
 - b. Pull adjuster cover in direction indicated by arrows as shown in the figure. Remove adjuster cover.

 : Pawl

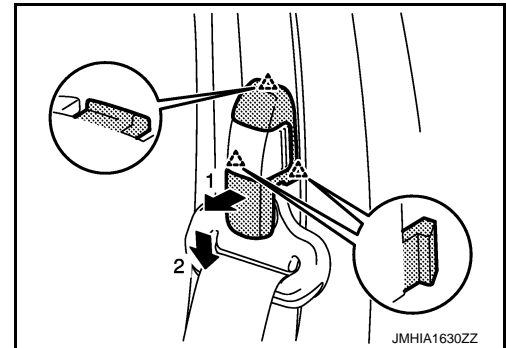

- c. Remove shoulder anchor mounting anchor bolt.
2. Remove outer anchor.
 - a. Pull outer anchor cover in direction indicated by arrows as shown in the figure. Remove outer anchor cover.

 : Pawl

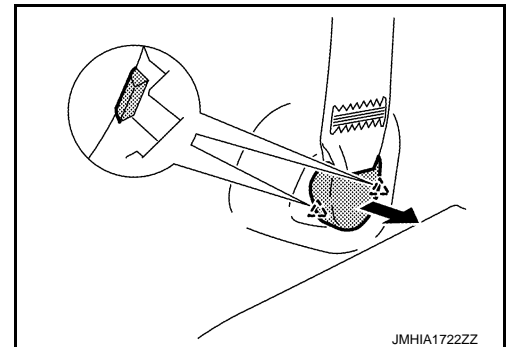

- b. Remove outer anchor mounting anchor bolt.
3. Remove seat belt pre-tensioner retractor.
 - a. Remove front kicking plate and rear kicking plate. Refer to [INT-22. "KICKING PLATE : Removal and Installation"](#).
 - b. Remove center pillar lower garnish. Refer to [INT-25. "CENTER PILLAR LOWER GARNISH : Removal and Installation"](#).
 - c. Disconnect seat belt pre-tensioner harness connector.

CAUTION:

FRONT SEAT BELT

< REMOVAL AND INSTALLATION >

- For installing/removing seat belt pre-tensioner connector, insert thin screwdriver wrapped in tape into notch, lift lock and remove connector.
- Install connector with lock raised, and push lock into connector.
- After installing the connector, check that the lock is pushed securely into it.

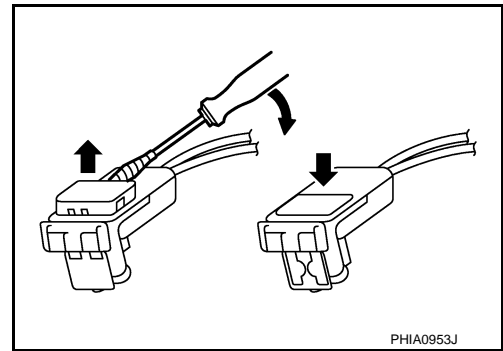

- d. Remove seat belt pre-tensioner retractor mounting anchor bolt and screw.

CAUTION:

Never place pre-tensioner seat belt in an area where the temperature reaches 80°C or more.

4. Remove seat belt adjuster.
- a. Remove center pillar upper garnish. Refer to [INT-26, "CENTER PILLAR UPPER GARNISH : Removal and Installation"](#).
- b. Remove seat belt adjuster mounting anchor bolts.

INSTALLATION

Install in the reverse order of removal.

SEAT BELT RETRACTOR : Inspection

INFOID:0000000011323295

AFTER A COLLISION

WARNING:

Inspect all seat belt assemblies including retractors and attached hardware after any collision. NISSAN/INFINITI recommends that all seat belt assemblies in use during a collision be replaced unless the collision was minor and the belts show no damage and continue to operate properly. Failure to do so could result in serious personal injury in an accident. Seat belt assemblies not in use during a collision should also be replaced if either damage or improper operation was noted. Seat belt pre-tensioners should be replaced even if the seat belts were not in use during a frontal collision in which the air bags were deployed.

Replace any seat belt assembly (including anchor bolts) if:

- The seat belt is in use at the time of a collision (except for minor collisions and the belts, retractors and buckles show no damage and continue to operate properly).
- The seat belt is damaged in an accident (i.e. torn webbing, bent retractor or guide, etc.).
- The seat belt attaching point is damaged in an accident. Inspect the seat belt attaching area for damage or distortion and repair if necessary before installing a new seat belt assembly.
- Anchor bolts are deformed or worn out.
- The seat belt pre-tensioners must be replaced even if the seat belts were not in use during the collision in which the air bags were deployed.

PRELIMINARY CHECKS

1. Check the seat belt warning lamp for proper operation as per the following:
 - a. Turn ignition switch ON. The seat belt warning lamp should illuminate.
 - b. Fasten driver seat belt. The seat belt warning lamp should turn OFF.
2. If the air bag warning lamp is blinking, perform self-diagnosis with CONSULT and air bag warning lamp. Refer to [SRC-15, "Description"](#).
3. Check that the seat belt retractor, seat belt anchor and buckle bolts are tightened firmly.
4. Check the shoulder seat belt guide and shoulder belt height adjuster for front seats. Check that guide swivels freely and that webbing lays flat and does not bind in guide. Check that height adjuster operates properly and holds securely.
5. Check retractor operation:
 - a. Fully extend the seat belt webbing and check for twists, tears or other damage.

FRONT SEAT BELT

< REMOVAL AND INSTALLATION >

- b. Allow the seat belt to retract. Check that webbing returns smoothly and completely into the retractor. If the seat belt does not return smoothly, wipe the inside of the loops with a clean paper cloth. Dirt build-up in the loops of the upper anchors can cause the seat belts to retract slowly.
- c. Fasten the seat belt. Check that seat belt returns smoothly and completely to the retractor. If the webbing does not return smoothly, the cause may be an accumulation of dust or dirt. Use the "SEAT BELT TAPE SET" and perform the following steps.

Inspect the front seat belt through-anchor

1. Pull the seat belt out to a length of 500 mm (19.69 in) or more.
2. Fix the seat belt at the center pillar webbing opening with a clip or other device.
3. Pass a thin wire through the through-anchor webbing opening. Hold both ends of the wire and pull it tightly while moving it up and down several times along the webbing opening surface to remove dirt stuck there.
4. Any dirt that cannot be removed with the wire can be removed by cleaning the opening with a clean cloth.
5. Apply tape at the point where the webbing contacts the through-anchor webbing opening.

NOTE:

Apply the tape so that there is no slack or wrinkling.

6. Remove the clip fixing the seat belt and check that the webbing returns smoothly.
6. Repeat steps above if necessary to check the other seat belts.

SEAT BELT RETRACTOR ON-VEHICLE CHECK

Emergency Locking Retractors (ELR) and Automatic Locking Retractors (ALR)

NOTE:

All seat belt retractors are Emergency Locking Retractors (ELR) type. In an emergency (sudden stop) the retractor will lock and prevent the webbing from extending any further. All 3-point type seat belt retractors except the driver seat belt also have an Automatic Locking Retractors (ALR) mode. The ALR mode (also called child restraint mode) is used when installing child seats. The ALR mode is activated when the seat belt is fully extended. When the webbing is then retracted partially, the ALR mode automatically locks the seat belt in a specific position so the webbing cannot be extended any further. To cancel the ALR mode, allow the seat belt to fully wind back into the retractor.

Check the seat belt retractors with the following test(s) to determine if a retractor assembly is operating properly.

ELR Function Stationary Check

Grasp the shoulder webbing and pull forward quickly. The retractor should lock and prevent the belt from extending further.

ALR Function Stationary Check

1. Pull out the entire length of seat belt from retractor until a click is heard.
2. Retract the webbing partially. A clicking noise should be heard as the webbing retracts indicating that the retractor is in the Automatic Locking Retractors (ALR) mode.
3. Grasp the seat belt and try to pull out the retractor. The webbing must lock and not extend any further. If it does not operate normally, replace the retractor assembly.
4. Allow the entire length of the webbing to retract to cancel the automatic locking mode.

ELR Function Moving Check

WARNING:

Perform the following test in a safe, open area clear of other vehicles and obstructions (for example, a large, empty parking lot). Road surface must be paved and dry. Never perform the following test on wet or gravel roads or on public streets and highways. This could result in an accident and serious personal injury. The driver and passenger must be prepared to brace themselves in the event that the retractor does not lock.

1. Fasten driver seat belt. Buckle a passenger into the seat for the belt that is to be tested.
2. Proceed to the designated safe area.
3. Drive the vehicle at approximately 16 km/h (10 MPH). Notify any passengers of a pending sudden stop and the driver and passenger must be prepared to brace themselves in the event that the retractor does not lock. Apply brakes firmly and make a very hard stop.

FRONT SEAT BELT

< REMOVAL AND INSTALLATION >

During stopping, seat belts should lock and not be extended. If the seat belt retractor assembly does not lock, perform the retractor off-vehicle check.

SEAT BELT RETRACTOR OFF-VEHICLE CHECK

1. Remove the front seat belt retractor. Refer to [SB-6, "SEAT BELT RETRACTOR : Removal and Installation"](#).
2. Slowly pull out webbing while tilting the retractor assembly forward from the mounted position without twisting the retractor assembly as shown in the figure.
 - The webbing can be pulled out when the angle (A) is 15 degrees or less.
 - The webbing cannot be pulled out when the angle (B) is 35 degrees or more.

A and B : Tilting angles

← : Vehicle front

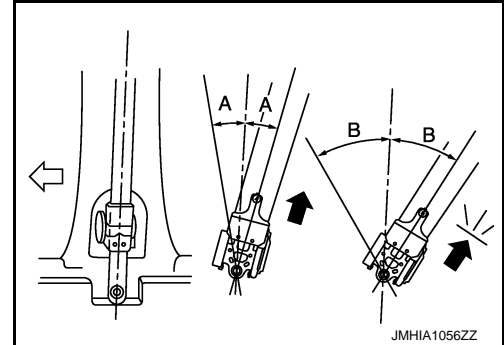

3. Replace the seat belt assembly if it does not operate normally.

SEAT BELT BUCKLE

SEAT BELT BUCKLE : Removal and Installation

INFOID:000000011323296

REMOVAL

WARNING:

Before servicing, turn ignition switch OFF, disconnect battery negative terminal and wait 3 minutes or more.

1. Remove front seat from the vehicle.
 - Manual seat: Refer to [SE-89, "Removal and Installation"](#).
 - Power seat: Refer to [SE-103, "Removal and Installation"](#).

CAUTION:

When removing and installing, use shop cloths to protect parts from damage.

2. Remove seat cushion finisher.
 - Manual seat: Refer to [SE-95, "SEAT CUSHION : Disassembly and Assembly"](#).
 - Power seat: Refer to [SE-109, "SEAT CUSHION : Disassembly and Assembly"](#).
3. Remove seat cushion inner finisher.
 - Manual seat: Refer to [SE-95, "SEAT CUSHION : Disassembly and Assembly"](#).
 - Power seat: Refer to [SE-109, "SEAT CUSHION : Disassembly and Assembly"](#).
4. Remove seat belt buckle.
 - a. Disconnect harness connector (A).

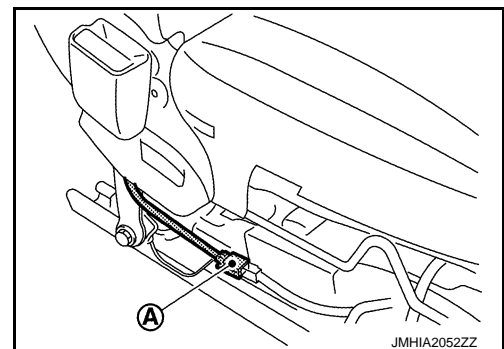

- b. Remove seat belt buckle mounting anchor bolt.

INSTALLATION

Install in the reverse order of removal.

FRONT SEAT BELT

< REMOVAL AND INSTALLATION >

SEAT BELT BUCKLE : Inspection

INFOID:000000011323297

AFTER A COLLISION

WARNING:

Inspect all seat belt assemblies including retractors and attached hardware after any collision.

NISSAN/INFINITI recommends that all seat belt assemblies in use during a collision be replaced unless the collision was minor and the belts show no damage and continue to operate properly. Failure to do so could result in serious personal injury in an accident. Seat belt assemblies not in use during a collision should also be replaced if either damage or improper operation was noted. Seat belt pre-tensioners should be replaced even if the seat belts were not in use during a frontal collision in which the air bags were deployed.

Replace any seat belt assembly (including anchor bolts) if:

- The seat belt is in use at the time of a collision (except for minor collisions and the belts, retractors and buckles show no damage and continue to operate properly).
- The seat belt is damaged in an accident (i.e. torn webbing, bent retractor or guide, etc.).
- The seat belt attaching point is damaged in an accident. Inspect the seat belt attaching area for damage or distortion and repair if necessary before installing a new seat belt assembly.
- Anchor bolts are deformed or worn out.
- The seat belt pre-tensioner must be replaced even if the seat belts were not in use during the collision in which the air bags were deployed.

PRELIMINARY CHECKS

1. Check the seat belt warning lamp for proper operation as per the following:
 - a. Turn ignition switch ON. The seat belt warning lamp should illuminate.
 - b. Fasten driver seat belt. The seat belt warning lamp should turn OFF.
2. If the air bag warning lamp is blinking, perform self-diagnosis using CONSULT and air bag warning lamp. Refer to [SRC-15, "Description"](#).
3. Check that the seat belt retractor, seat belt anchor and buckle bolts are tightened firmly.
4. Repeat steps above if necessary to check the other seat belts.

SECOND SEAT BELT

< REMOVAL AND INSTALLATION >

SECOND SEAT BELT

Exploded View

INFOID:000000011323298

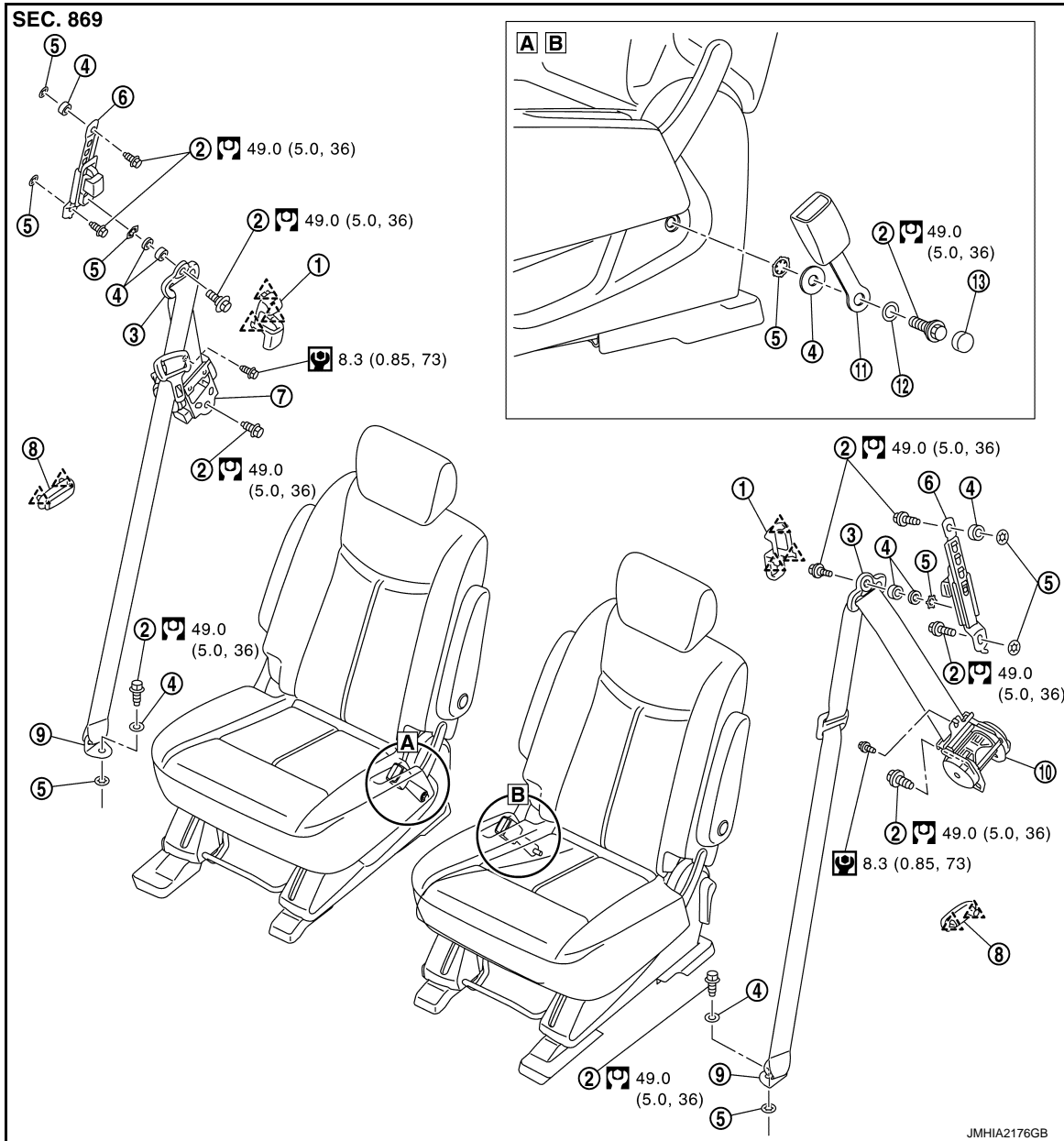

- | | | |
|-----------------------------------|-----------------------------|-----------------------|
| 1. Adjuster cover | 2. Anchor bolt | 3. Shoulder anchor |
| 4. Spacer | 5. Retaining washer | 6. Seat belt adjuster |
| 7. Second seat belt retractor RH | 8. Seat belt hook | 9. Outer anchor |
| 10. Second seat belt retractor LH | 11. Second seat belt buckle | 12. Wave washer |
| 13. Anchor bolt cap | | |

△ : Pawl

⊙ : N·m (kg-m, in-lb)

⊙ : N·m (kg-m, ft-lb)

SEAT BELT RETRACTOR

A
B
C
D
E
F
G
SB
I
J
K
L
M
N
O
P

SECOND SEAT BELT

< REMOVAL AND INSTALLATION >

SEAT BELT RETRACTOR : Removal and Installation

INFOID:000000011323299

REMOVAL

1. Remove shoulder anchor.
 - a. Slide second seat to the frontmost position.
 - b. Pull adjuster cover in direction indicated by arrows as shown in the figure. Remove adjuster cover.

 : Pawl

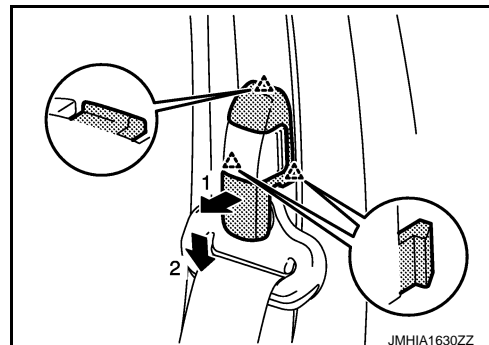

- c. Remove shoulder anchor mounting anchor bolt.
2. Remove outer anchor.
 - a. Remove rear kicking plate. Refer to [INT-22. "KICKING PLATE : Removal and Installation"](#).
 - b. Remove outer anchor mounting anchor bolt.
3. Remove second seat belt retractor.
 - a. Remove luggage side lower finisher. Refer to [INT-43. "LUGGAGE SIDE LOWER FINISHER : Removal and Installation"](#).
4. Remove second seat belt retractor mounting anchor bolt and screw.
5. Remove seat belt adjuster.
 - a. Remove rear pillar garnish. Refer to [INT-27. "REAR PILLAR GARNISH : Removal and Installation"](#).
 - b. Remove seat belt adjuster mounting anchor bolts.

INSTALLATION

Install in the reverse order of removal.

SEAT BELT RETRACTOR : Inspection

INFOID:000000011323300

AFTER A COLLISION

WARNING:

Inspect all seat belt assemblies including retractors and attached hardware after any collision. NISSAN/INFINITI recommends that all seat belt assemblies in use during a collision be replaced unless the collision was minor and the belts show no damage and continue to operate properly. Failure to do so could result in serious personal injury in an accident. Seat belt assemblies not in use during a collision should also be replaced if either damage or improper operation was noted. Seat belt pre-tensioners should be replaced even if the seat belts were not in use during a frontal collision in which the air bags were deployed.

Replace any seat belt assembly (including anchor bolts) if:

- The seat belt is in use at the time of a collision (except for minor collisions and the belts, retractors and buckles show no damage and continue to operate properly).
- The seat belt is damaged in an accident (i.e. torn webbing, bent retractor or guide, etc.).
- The seat belt attaching point is damaged in an accident. Inspect the seat belt attaching area for damage or distortion and repair if necessary before installing a new seat belt assembly.
- Anchor bolts are deformed or worn out.
- The seat belt pre-tensioners must be replaced even if the seat belts were not in use during the collision in which the air bags were deployed.

PRELIMINARY CHECKS

1. Check that the seat belt retractor, seat belt anchor and buckle bolts are tightened firmly.
2. Check retractor operation:
 - a. Fully extend the seat belt webbing and check for twists, tears or other damage.

SECOND SEAT BELT

< REMOVAL AND INSTALLATION >

- b. Allow the seat belt to retract. Check that webbing returns smoothly and completely into the retractor. If the seat belt does not return smoothly, wipe the inside of the loops with a clean paper cloth. Dirt build-up in the loops of that upper anchors can cause the seat belts to retract slowly.
 - c. Fasten the seat belt. Check that seat belt returns smoothly and completely to the retractor. If the webbing does not return smoothly, the cause may be an accumulation of dust or dirt. Use the "SEAT BELT TAPE SET" and perform the following steps.
3. Repeat steps above if necessary to check the other seat belts.

SEAT BELT RETRACTOR ON-VEHICLE CHECK

Emergency Locking Retractors (ELR) and Automatic Locking Retractors (ALR)

NOTE:

All seat belt retractors are Emergency Locking Retractors (ELR) type. In an emergency (sudden stop) the retractor will lock and prevent the webbing from extending any further. All 3-point type seat belt retractors except the driver seat belt also have an Automatic Locking Retractors (ALR) mode. The ALR mode (also called child restraint mode) is used when installing child seats. The ALR mode is activated when the seat belt is fully extended. When the webbing is then retracted partially, the ALR mode automatically locks the seat belt in a specific position so the webbing cannot be extended any further. To cancel the ALR mode, allow the seat belt to fully wind back into the retractor.

Check the seat belt retractors with the following test(s) to determine if a retractor assembly is operating properly.

ELR Function Stationary Check

Grasp the shoulder webbing and pull forward quickly. The retractor should lock and prevent the belt from extending further.

ALR Function Stationary Check

1. Pull out the entire length of seat belt from retractor until a click is heard.
2. Retract the webbing partially. A clicking noise should be heard as the webbing retracts indicating that the retractor is in the Automatic Locking Retractors (ALR) mode.
3. Grasp the seat belt and try to pull out the retractor. The webbing must lock and not extend any further. If it does not operate normally, replace the retractor assembly.
4. Allow the entire length of the webbing to retract to cancel the automatic locking mode.

ELR Function Moving Check

WARNING:

Perform the following test in a safe, open area clear of other vehicles and obstructions (for example, a large, empty parking lot). Road surface must be paved and dry. Never perform the following test on wet or gravel roads or on public streets and highways. This could result in an accident and serious personal injury. The driver and passenger must be prepared to brace themselves in the event that the retractor does not lock.

1. Fasten driver seat belt. Buckle a passenger into the seat for the belt that is to be tested.
2. Proceed to the designated safe area.
3. Drive the vehicle at approximately 16 km/h (10 MPH). Notify any passengers of a pending sudden stop and the driver and passenger must be prepared to brace themselves in the event that the retractor does not lock. Apply brakes firmly and make a very hard stop.

During stopping, seat belts should lock and not be extended. If the seat belt retractor assembly does not lock, perform the retractor off-vehicle check.

SEAT BELT RETRACTOR OFF-VEHICLE CHECK

1. Remove the second seat belt retractor. Refer to [SB-12, "SEAT BELT RETRACTOR : Removal and Installation"](#).
2. Slowly pull out webbing while tilting the retractor assembly forward from the mounted position without twisting the retractor assembly as shown in the figure.

SECOND SEAT BELT

< REMOVAL AND INSTALLATION >

- The webbing can be pulled out when the angle (A) is 15 degrees or less.
- The webbing cannot be pulled out when the angle (B) is 35 degrees or more.

A and B : Tilting angles
⇐ : Vehicle front

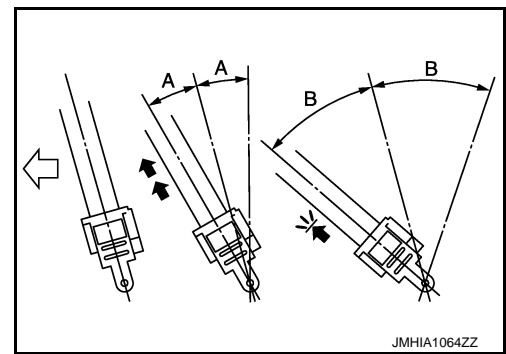

3. Replace the seat belt assembly if it does not operate normally.

SEAT BELT BUCKLE

SEAT BELT BUCKLE : Removal and Installation

INFOID:000000011323301

REMOVAL

1. Remove anchor bolt cap.
2. Remove seat belt buckle mounting anchor bolt, and then remove seat belt buckle.

INSTALLATION

Install in the reverse order of removal.

SEAT BELT BUCKLE : Inspection

INFOID:000000011323302

AFTER A COLLISION

WARNING:

Inspect all seat belt assemblies including retractors and attached hardware after any collision. NISSAN/INFINITI recommends that all seat belt assemblies in use during a collision be replaced unless the collision was minor and the belts show no damage and continue to operate properly. Failure to do so could result in serious personal injury in an accident. Seat belt assemblies not in use during a collision should also be replaced if either damage or improper operation was noted. Seat belt pre-tensioners should be replaced even if the seat belts were not in use during a frontal collision in which the air bags were deployed.

Replace any seat belt assembly (including anchor bolts) if:

- The seat belt is in use at the time of a collision (except for minor collisions and the belts, retractors and buckles show no damage and continue to operate properly).
- The seat belt is damaged in an accident. (i.e. torn webbing, bent retractor or guide, etc.)
- The seat belt attaching point is damaged in an accident. Inspect the seat belt attaching area for damage or distortion and repair if necessary before installing a new seat belt assembly.
- Anchor bolts are deformed or worn out.
- The seat belt pre-tensioner must be replaced even if the seat belts were not in use during the collision in which the air bags are deployed.

PRELIMINARY CHECKS

1. Check that the seat belt retractor, seat belt anchor and buckle bolts are tightened firmly.
2. Repeat step above if necessary to check the other seat belts.

SEAT BELT HOOK

SEAT BELT HOOK : Removal and Installation

INFOID:000000011323303

REMOVAL

1. Slide second seat to the frontmost position.
2. Remove third seat from the vehicle. Refer to [SE-126, "Removal and Installation"](#).
3. Remove luggage side lower finisher. Refer to [INT-43, "LUGGAGE SIDE LOWER FINISHER : Removal and Installation"](#).

SECOND SEAT BELT

< REMOVAL AND INSTALLATION >

4. From back of luggage side lower finisher, press pawls indicated by arrows as shown in the figure and remove seat belt hook from luggage side lower finisher.

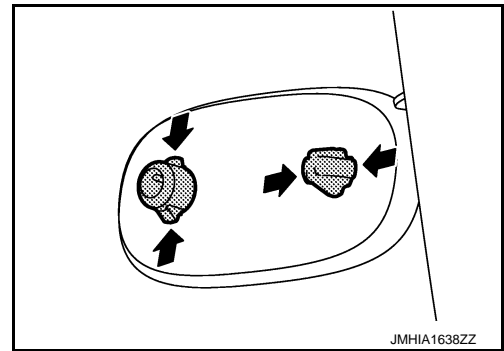

INSTALLATION

Install in the reverse order of removal.

A
B
C
D
E
F
G
I
J
K
L
M
N
O
P

SB

THIRD SEAT BELT

< REMOVAL AND INSTALLATION >

THIRD SEAT BELT

Exploded View

INFOID:000000011323304

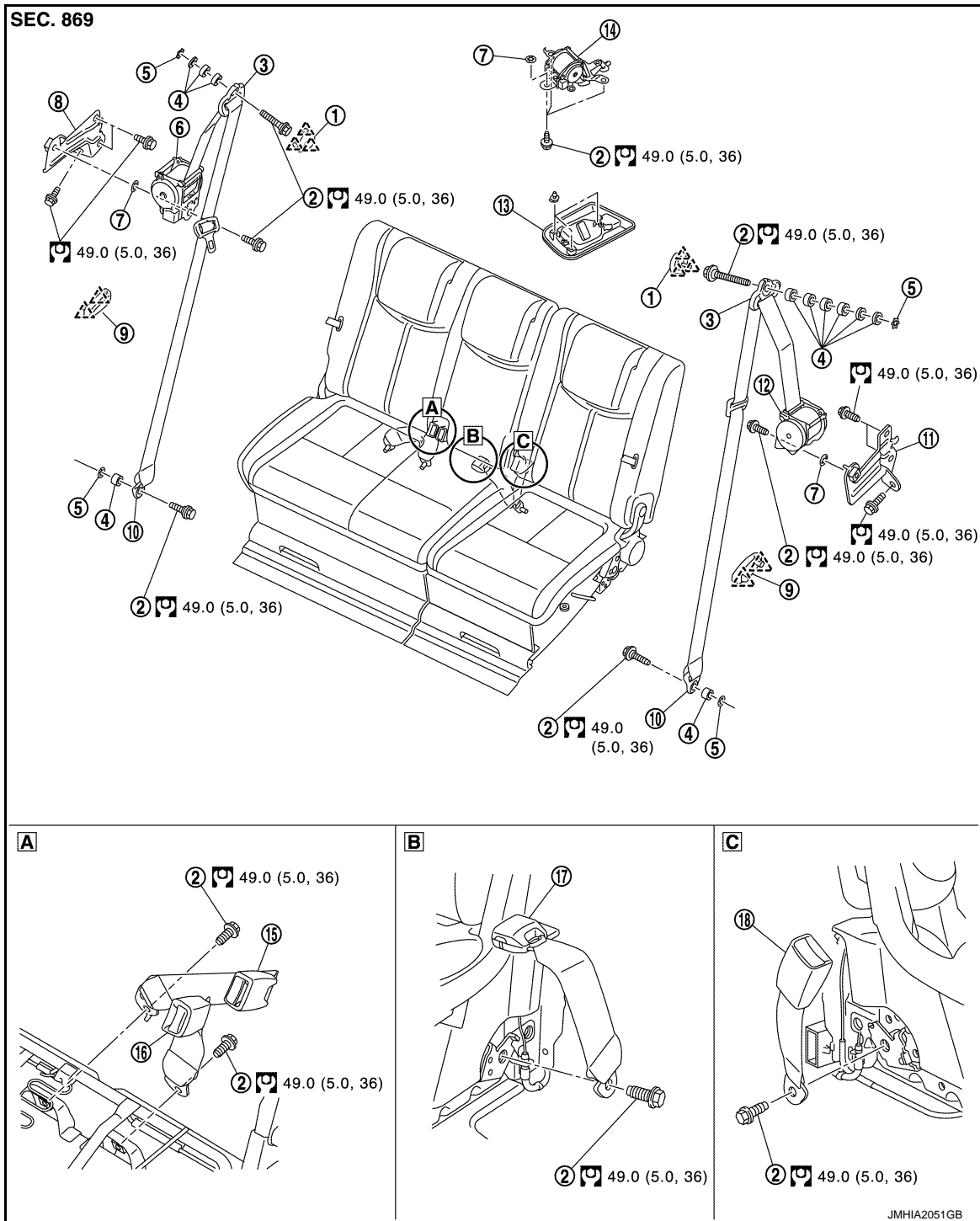



- | | | |
|---|-----------------------------------|----------------------------------|
| 1. Shoulder anchor cover | 2. Anchor bolt | 3. Shoulder anchor |
| 4. Spacer | 5. Retaining washer | 6. Outer seat belt retractor RH |
| 7. Locking washer | 8. Seat belt shoulder bracket RH | 9. Seat belt hook |
| 10. Outer anchor | 11. Seat belt shoulder bracket LH | 12. Outer seat belt retractor LH |
| 13. Center seat belt retractor finisher | 14. Center seat belt retractor | 15. Center seat belt buckle |
| 16. Outer seat belt buckle RH | 17. Connector buckle | 18. Outer seat belt buckle LH |

JMHIA2051GB

THIRD SEAT BELT

< REMOVAL AND INSTALLATION >

 : Pawl

 : N·m (kg·m, ft·lb)

SEAT BELT RETRACTOR

SEAT BELT RETRACTOR : Removal and Installation

INFOID:000000011323305

REMOVAL

OUTER SEAT BELT RETRACTOR

1. Remove shoulder anchor.
 - a. Pull shoulder anchor cover in direction indicated by arrows as shown in the figure. Remove outer anchor cover.

 : Pawl

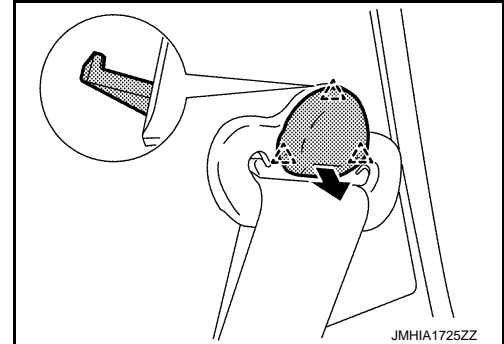

- b. Remove shoulder anchor mounting anchor bolt.
2. Remove outer anchor mounting anchor bolt, and then remove outer anchor.
3. Remove outer seat belt retractor.
- a. Remove luggage side lower finisher. Refer to [INT-43, "LUGGAGE SIDE LOWER FINISHER : Removal and Installation"](#).
- b. Remove outer anchor mounting anchor bolt.
4. Remove seat belt shoulder bracket mounting bolts, and then remove seat belt shoulder bracket.

CENTER SEAT BELT RETRACTOR

1. Remove center seat belt retractor finisher.
Disengage center seat belt finisher fixing clips, and then remove center seat belt retractor finisher.

 : Clip

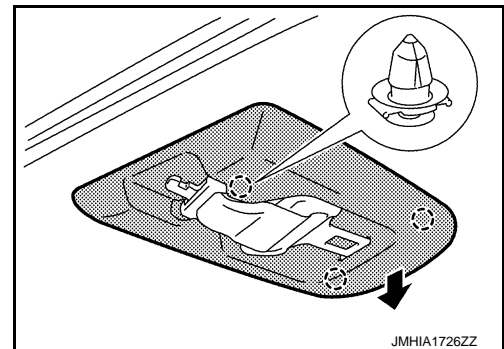

2. Remove center seat belt retractor.
 - a. Remove third assist grip (LH and RH), and then remove headlining assembly rear clips.
Refer to [INT-35, "Removal and Installation"](#).

THIRD SEAT BELT

< REMOVAL AND INSTALLATION >

- b. Slightly lower the headlining assembly (1) rear and secure work space.
- c. Remove outer seat belt retractor mounting anchor bolts (A), and then remove outer seat belt retractor (2).

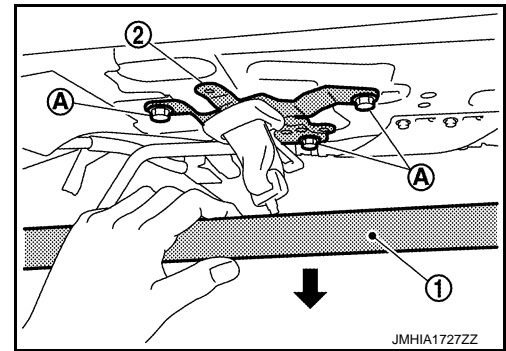

INSTALLATION

Install in the reverse order of removal.

SEAT BELT RETRACTOR : Inspection

INFOID:000000011323306

AFTER A COLLISION

WARNING:

Inspect all seat belt assemblies including retractors and attached hardware after any collision. NISSAN/INFINITI recommends that all seat belt assemblies in use during a collision be replaced unless the collision was minor and the belts show no damage and continue to operate properly. Failure to do so could result in serious personal injury in an accident. Seat belt assemblies not in use during a collision should also be replaced if either damage or improper operation was noted. Seat belt pre-tensioners should be replaced even if the seat belts were not in use during a frontal collision in which the air bags were deployed.

Replace any seat belt assembly (including anchor bolts) if:

- The seat belt is in use at the time of a collision (except for minor collisions and the belts, retractors and buckles show no damage and continue to operate properly).
- The seat belt is damaged in an accident (i.e. torn webbing, bent retractor or guide, etc.).
- The seat belt attaching point is damaged in an accident. Inspect the seat belt attaching area for damage or distortion and repair if necessary before installing a new seat belt assembly.
- Anchor bolts are deformed or worn out.
- The seat belt pre-tensioners must be replaced even if the seat belts were not in use during the collision in which the air bags were deployed.

PRELIMINARY CHECKS

1. Check that the seat belt retractor, seat belt anchor and buckle bolts are tightened firmly.
2. Check retractor operation:
 - a. Fully extend the seat belt webbing and check for twists, tears or other damage.
 - b. Allow the seat belt to retract. Check that webbing returns smoothly and completely into the retractor. If the seat belt does not return smoothly, wipe the inside of the loops with a clean paper cloth. Dirt build-up in the loops of that upper anchors can cause the seat belts to retract slowly.
 - c. Fasten the seat belt. Check that seat belt returns smoothly and completely to the retractor. If the webbing does not return smoothly, the cause may be an accumulation of dust or dirt. Use the "SEAT BELT TAPE SET" and perform the following steps.
3. Repeat steps above if necessary to check the other seat belts.

SEAT BELT RETRACTOR ON-VEHICLE CHECK

Emergency Locking Retractors (ELR) and Automatic Locking Retractors (ALR)

NOTE:

All seat belt retractors are Emergency Locking Retractors (ELR) type. In an emergency (sudden stop) the retractor will lock and prevent the webbing from extending any further. All 3-point type seat belt retractors except the driver seat belt also have an Automatic Locking Retractors (ALR) mode. The ALR mode (also called child restraint mode) is used when installing child seats. The ALR mode is activated when the seat belt is fully extended. When the webbing is then retracted partially, the ALR mode automatically locks the seat belt in a specific position so the webbing cannot be extended any further. To cancel the ALR mode, allow the seat belt to fully wind back into the retractor.

THIRD SEAT BELT

< REMOVAL AND INSTALLATION >

Check the seat belt retractors with the following test(s) to determine if a retractor assembly is operating properly.

ELR Function Stationary Check

Grasp the shoulder webbing and pull forward quickly. The retractor should lock and prevent the belt from extending further.

ALR Function Stationary Check

1. Pull out the entire length of seat belt from retractor until a click is heard.
2. Retract the webbing partially. A clicking noise should be heard as the webbing retracts indicating that the retractor is in the Automatic Locking Retractors (ALR) mode.
3. Grasp the seat belt and try to pull out the retractor. The webbing must lock and not extend any further. If it does not operate normally, replace the retractor assembly.
4. Allow the entire length of the webbing to retract to cancel the automatic locking mode.

ELR Function Moving Check

WARNING:

Perform the following test in a safe, open area clear of other vehicles and obstructions (for example, a large, empty parking lot). Road surface must be paved and dry. Never perform the following test on wet or gravel roads or on public streets and highways. This could result in an accident and serious personal injury. The driver and passenger must be prepared to brace themselves in the event that the retractor does not lock.

1. Fasten driver seat belt. Buckle a passenger into the seat for the belt that is to be tested.
2. Proceed to the designated safe area.
3. Drive the vehicle at approximately 16 km/h (10 MPH). Notify any passengers of a pending sudden stop and the driver and passenger must be prepared to brace themselves in the event that the retractor does not lock. Apply brakes firmly and make a very hard stop.

During stopping, seat belts should lock and not be extended. If the seat belt retractor assembly does not lock, perform the retractor off-vehicle check.

SEAT BELT RETRACTOR OFF-VEHICLE CHECK

1. Remove the third seat belt retractor. Refer to [SB-17. "SEAT BELT RETRACTOR : Removal and Installation"](#).
2. Slowly pull out webbing while tilting the retractor assembly forward from the mounted position without twisting the retractor assembly as shown in the figure.
 - a. Outer seat belt retractor
 - The webbing can be pulled out when the angle (A) is 15 degrees or less.
 - The webbing cannot be pulled out when the angle (B) is 35 degrees or more.

A and B : Tilting angles

← : Vehicle front

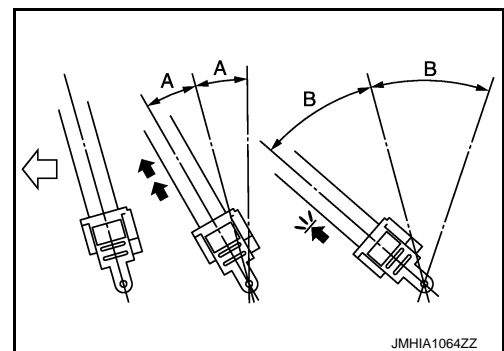

- b. Center seat belt retractor

THIRD SEAT BELT

< REMOVAL AND INSTALLATION >

- The webbing can be pulled out when the angle (A) is 15 degrees or less.
- The webbing cannot be pulled out when the angle (B) is 35 degrees or more.

A and B : Tilting angles

← : Vehicle front

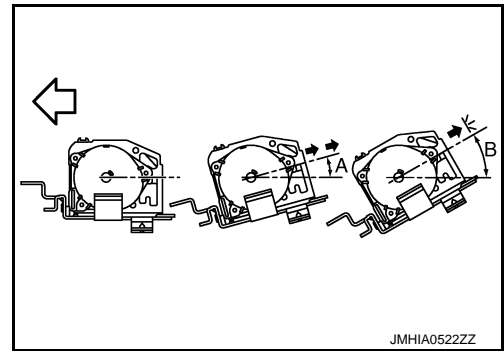

3. Replace the seat belt assembly if it does not operate normally.

SEAT BELT BUCKLE

SEAT BELT BUCKLE : Removal and Installation

INFOID:000000011323307

REMOVAL

OUTER SEAT BELT BUCKLE RH & CENTER SEAT BELT BUCKLE

1. Remove luggage floor rear board. Refer to [INT-40, "LUGGAGE FLOOR REAR BOARD : Removal and Installation"](#).
2. Remove cable cover. Refer to [INT-41, "CABLE COVER : Removal and Installation"](#).
3. Remove outer seat belt buckle RH.
 - a. Remove outer seat belt buckle RH mounting anchor bolt.
4. Pull up seat belt buckle from the seat back and remove it.

CONNECTOR BUCKLE

1. Remove third seat RH from the vehicle. Refer to [SE-126, "Removal and Installation"](#).
CAUTION:
When removing and installing, use shop cloths to protect parts from damage.
2. Remove connector buckle mounting anchor bolt, and then remove connector buckle.

OUTER SEAT BELT BUCKLE LH

1. Remove third seat LH from the vehicle. Refer to [SE-126, "Removal and Installation"](#).
CAUTION:
When removing and installing, use shop cloths to protect parts from damage.
2. Remove outer seat belt buckle LH mounting anchor bolt, and then remove outer seat belt buckle LH.

INSTALLATION

Install in the reverse order of removal.

SEAT BELT BUCKLE : Inspection

INFOID:000000011323308

AFTER A COLLISION

WARNING:

Inspect all seat belt assemblies including retractors and attached hardware after any collision. NISSAN/INFINITI recommends that all seat belt assemblies in use during a collision be replaced unless the collision was minor and the belts show no damage and continue to operate properly. Failure to do so could result in serious personal injury in an accident. Seat belt assemblies not in use during a collision should also be replaced if either damage or improper operation was noted. Seat belt pre-tensioners should be replaced even if the seat belts were not in use during a frontal collision in which the air bags were deployed.

Replace any seat belt assembly (including anchor bolts) if:

- The seat belt is in use at the time of a collision (except for minor collisions and the belts, retractors and buckles show no damage and continue to operate properly).
- The seat belt is damaged in an accident. (i.e. torn webbing, bent retractor or guide, etc.)
- The seat belt attaching point is damaged in an accident. Inspect the seat belt attaching area for damage or distortion and repair if necessary before installing a new seat belt assembly.

THIRD SEAT BELT

< REMOVAL AND INSTALLATION >

- Anchor bolts are deformed or worn out.
- The seat belt pre-tensioner must be replaced even if the seat belts were not in use during the collision in which the air bags are deployed.

PRELIMINARY CHECKS

1. Check that the seat belt retractor, seat belt anchor and buckle bolts are tightened firmly.
2. Repeat step above if necessary to check the other seat belts.

SEAT BELT HOOK

SEAT BELT HOOK : Removal and Installation

INFOID:000000011323309

REMOVAL

1. Slide second seat to the frontmost position.
2. Remove third seat from the vehicle. Refer to [SE-126, "Removal and Installation"](#).
3. Remove luggage side lower finisher. Refer to [INT-43, "LUGGAGE SIDE LOWER FINISHER : Removal and Installation"](#).
4. From back of luggage side lower finisher, press pawls indicated by arrows as shown in the figure and remove seat belt hook from luggage side lower finisher.

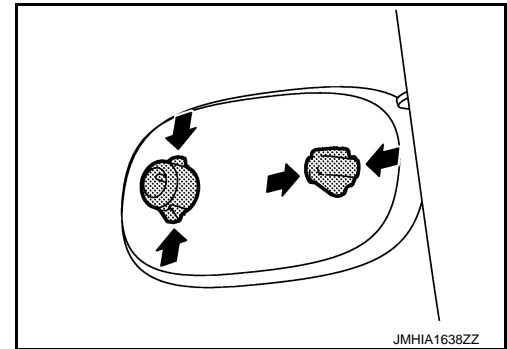

INSTALLATION

Install in the reverse order of removal.