

SECTION **SE**  
SEAT

A  
B  
C  
D  
E  
F  
G  
H  
I  
SE  
K  
L  
M  
N  
O  
P

CONTENTS

<b>PRECAUTION</b> .....	4	Seat Cushion Heater .....	11
<b>PRECAUTIONS</b> .....	4	Heated Seat Switch .....	11
Precaution for Supplemental Restraint System (SRS) "AIR BAG" and "SEAT BELT PRE-TENSIONER" .....	4	Third Seat Fold Switch .....	11
Precautions for Removing Battery Terminal .....	4	Sector Gear .....	11
Precautions For Xenon Headlamp Service .....	4	Sector Gear Position Limit Switch .....	11
Service Notice .....	5	Power Return Motor Assembly .....	11
Precaution for Work .....	5	Seatback Angle Limit Switch .....	11
<b>PREPARATION</b> .....	6	Seatback Lock Release Actuator Relay .....	11
<b>PREPARATION</b> .....	6	Seatback Lock Release Actuator .....	11
Special Service Tool .....	6	Seatback Power Return Control Unit .....	12
Commercial Service Tool .....	6	<b>SYSTEM</b> .....	13
<b>CLIP LIST</b> .....	7	<b>POWER SEAT SYSTEM</b> .....	13
Clip List .....	7	POWER SEAT SYSTEM : System Description .....	13
<b>SYSTEM DESCRIPTION</b> .....	8	<b>HEATED SEAT SYSTEM</b> .....	13
<b>COMPONENT PARTS</b> .....	8	HEATED SEAT SYSTEM : System Description .....	13
<b>POWER SEAT SYSTEM</b> .....	8	<b>SEATBACK POWER FOLDING/RETURN SYSTEM</b> .....	13
POWER SEAT SYSTEM : Component Parts Location .....	8	SEATBACK POWER FOLDING/RETURN SYSTEM : System Description .....	13
<b>HEATED SEAT SYSTEM</b> .....	8	SEATBACK POWER FOLDING/RETURN SYSTEM : Circuit Diagram .....	17
HEATED SEAT SYSTEM : Component Parts Location .....	9	SEATBACK POWER FOLDING/RETURN SYSTEM : Fail-safe .....	17
<b>SEATBACK POWER FOLDING/RETURN SYSTEM</b> .....	9	<b>ECU DIAGNOSIS INFORMATION</b> .....	19
SEATBACK POWER FOLDING/RETURN SYSTEM : Component Parts Location .....	10	<b>SEATBACK POWER RETURN CONTROL UNIT</b> .....	19
Reclining Motor .....	11	Reference Value .....	19
Sliding Motor .....	11	Fail-safe .....	21
Power Seat Switch .....	11	<b>WIRING DIAGRAM</b> .....	22
Lumbar Support Switch .....	11	<b>POWER SEAT CONTROL SYSTEM</b> .....	22
Lifting Motor .....	11	<b>DRIVER SIDE</b> .....	22
Lumbar Support Motor .....	11	DRIVER SIDE : Wiring Diagram .....	22
Seatback Heater .....	11	<b>PASSENGER SIDE</b> .....	25

PASSENGER SIDE : Wiring Diagram .....	26	<b>RH</b> .....	<b>64</b>
		RH : Diagnosis Procedure .....	64
		Component Inspection .....	65
<b>LUMBAR SUPPORT SYSTEM</b> .....	<b>29</b>	<b>POWER RETURN MOTOR</b> .....	<b>66</b>
Wiring Diagram .....	29	<b>LH</b> .....	<b>66</b>
		LH : Diagnosis Procedure .....	66
<b>HEATED SEAT SYSTEM</b> .....	<b>33</b>	<b>RH</b> .....	<b>66</b>
Wiring Diagram .....	33	RH : Diagnosis Procedure .....	66
<b>SEATBACK POWER RETURN SYSTEM</b> .....	<b>37</b>	<b>MOTOR SENSOR</b> .....	<b>68</b>
Wiring Diagram .....	37	<b>LH</b> .....	<b>68</b>
		LH : Diagnosis Procedure .....	68
<b>SEATBACK POWER FOLDING SYSTEM</b> .....	<b>44</b>	<b>RH</b> .....	<b>69</b>
Wiring Diagram .....	44	RH : Diagnosis Procedure .....	69
<b>BASIC INSPECTION</b> .....	<b>48</b>	<b>SYMPTOM DIAGNOSIS</b> .....	<b>72</b>
<b>DIAGNOSIS AND REPAIR WORK FLOW</b> .....	<b>48</b>	<b>SEATBACK DOES NOT OPERATE POWER RETURN</b> .....	<b>72</b>
Work Flow .....	48	<b>BOTH SIDES</b> .....	<b>72</b>
		BOTH SIDES : Diagnosis Procedure .....	72
<b>DTC/CIRCUIT DIAGNOSIS</b> .....	<b>49</b>	<b>LH</b> .....	<b>72</b>
		LH : Diagnosis Procedure .....	72
<b>POWER SUPPLY AND GROUND CIRCUIT</b> ....	<b>49</b>	<b>RH</b> .....	<b>73</b>
Diagnosis Procedure .....	49	RH : Diagnosis Procedure .....	73
<b>THIRD SEAT FOLD SWITCH</b> .....	<b>50</b>	<b>DOES NOT RETURN BUT MALFUNCTION DETECTION BUZZER SOUNDS</b> .....	<b>74</b>
<b>LH</b> .....	<b>50</b>	<b>LH</b> .....	<b>74</b>
LH : Component Function Check .....	50	LH : Diagnosis Procedure .....	74
LH : Diagnosis Procedure .....	50	<b>RH</b> .....	<b>74</b>
<b>RH</b> .....	<b>52</b>	RH : Diagnosis Procedure .....	74
RH : Component Function Check .....	52	<b>SEATBACK DOES NOT FOLD DOWN BY SWITCH OPERATION</b> .....	<b>75</b>
RH : Diagnosis Procedure .....	52	<b>BOTH SIDES</b> .....	<b>75</b>
Component Inspection (Third Seat Fold Switch) ...	54	BOTH SIDES : Diagnosis Procedure .....	75
Component Inspection (Seatback Lock Release Actuator Relay) .....	54	<b>LH</b> .....	<b>75</b>
		LH : Diagnosis Procedure .....	75
<b>VEHICLE SPEED SIGNAL CIRCUIT</b> .....	<b>55</b>	<b>RH</b> .....	<b>75</b>
Diagnosis Procedure .....	55	RH : Diagnosis Procedure .....	75
<b>SEATBACK ANGLE LIMIT SWITCH</b> .....	<b>56</b>	<b>MALFUNCTION DETECTION BUZZER SOUNDS DURING POWER RETURN MOTOR INVERSE ROTATION</b> .....	<b>77</b>
<b>LH</b> .....	<b>56</b>	<b>LH</b> .....	<b>77</b>
LH : Diagnosis Procedure .....	56	LH : Diagnosis Procedure .....	77
<b>RH</b> .....	<b>57</b>	<b>RH</b> .....	<b>77</b>
RH : Diagnosis Procedure .....	57	RH : Diagnosis Procedure .....	77
Component Inspection .....	58		
<b>SEATBACK LOCK RELEASE ACTUATOR</b> ....	<b>59</b>		
<b>LH</b> .....	<b>59</b>		
LH : Diagnosis Procedure .....	59		
<b>RH</b> .....	<b>60</b>		
RH : Diagnosis Procedure .....	60		
Component Inspection (Seatback Lock Release Actuator Relay) .....	62		
<b>SECTOR GEAR POSITION LIMIT SWITCH</b> ....	<b>63</b>		
<b>LH</b> .....	<b>63</b>		
LH : Diagnosis Procedure .....	63		

<b>ANTI-PINCH FUNCTION DOES NOT OPERATE</b> .....	<b>79</b>	<b>SECOND SEAT</b> .....	<b>114</b>	
Diagnosis Procedure .....	79	Exploded View .....	114	A
<b>SQUEAK AND RATTLE TROUBLE DIAGNOSES</b> .....	<b>80</b>	Removal and Installation .....	115	
Work Flow .....	80	<b>SEATBACK</b> .....	<b>116</b>	B
Inspection Procedure .....	82	SEATBACK : Disassembly and Assembly .....	116	
Diagnostic Worksheet .....	84	<b>SEAT CUSHION</b> .....	<b>119</b>	C
<b>REMOVAL AND INSTALLATION</b> .....	<b>86</b>	SEAT CUSHION : Disassembly and Assembly ....	119	
<b>FRONT SEAT (MANUAL SEAT)</b> .....	<b>86</b>	<b>THIRD SEAT</b> .....	<b>123</b>	
Exploded View .....	86	Exploded View .....	123	D
Removal and Installation .....	89	Removal and Installation .....	126	
<b>SEATBACK</b> .....	<b>91</b>	<b>SEATBACK</b> .....	<b>128</b>	E
SEATBACK : Disassembly and Assembly .....	91	SEATBACK : Disassembly and Assembly .....	128	
<b>SEAT CUSHION</b> .....	<b>95</b>	<b>SEAT CUSHION</b> .....	<b>133</b>	F
SEAT CUSHION : Disassembly and Assembly ....	95	SEAT CUSHION : Disassembly and Assembly ....	133	
<b>FRONT SEAT (POWER SEAT)</b> .....	<b>100</b>	<b>THIRD SEAT FOLD SWITCH</b> .....	<b>137</b>	
Exploded View .....	100	Removal and Installation .....	137	G
Removal and Installation .....	103	<b>LUMBAR SUPPORT SWITCH</b> .....	<b>138</b>	
<b>SEATBACK</b> .....	<b>105</b>	Removal and Installation .....	138	
SEATBACK : Disassembly and Assembly .....	105	<b>HEATED SEAT SWITCH</b> .....	<b>139</b>	H
<b>SEAT CUSHION</b> .....	<b>109</b>	Removal and Installation .....	139	
SEAT CUSHION : Disassembly and Assembly ...	109	<b>SEATBACK POWER RETURN CONTROL UNIT</b> .....	<b>140</b>	I
		Removal and Installation .....	140	

**SE**

K  
L  
M  
N  
O  
P

# PRECAUTIONS

< PRECAUTION >

## PRECAUTION

### PRECAUTIONS

#### Precaution for Supplemental Restraint System (SRS) "AIR BAG" and "SEAT BELT PRE-TENSIONER"

INFOID:000000011325248

The Supplemental Restraint System such as "AIR BAG" and "SEAT BELT PRE-TENSIONER", used along with a front seat belt, helps to reduce the risk or severity of injury to the driver and front passenger for certain types of collision. This system includes seat belt switch inputs and dual stage front air bag modules. The SRS system uses the seat belt switches to determine the front air bag deployment, and may only deploy one front air bag, depending on the severity of a collision and whether the front occupants are belted or unbelted. Information necessary to service the system safely is included in the "SRS AIR BAG" and "SEAT BELT" of this Service Manual.

#### **WARNING:**

Always observe the following items for preventing accidental activation.

- To avoid rendering the SRS inoperative, which could increase the risk of personal injury or death in the event of a collision that would result in air bag inflation, all maintenance must be performed by an authorized NISSAN/INFINITI dealer.
- Improper maintenance, including incorrect removal and installation of the SRS, can lead to personal injury caused by unintentional activation of the system. For removal of Spiral Cable and Air Bag Module, see "SRS AIR BAG".
- Never use electrical test equipment on any circuit related to the SRS unless instructed to in this Service Manual. SRS wiring harnesses can be identified by yellow and/or orange harnesses or harness connectors.

#### PRECAUTIONS WHEN USING POWER TOOLS (AIR OR ELECTRIC) AND HAMMERS

#### **WARNING:**

Always observe the following items for preventing accidental activation.

- When working near the Air Bag Diagnosis Sensor Unit or other Air Bag System sensors with the ignition ON or engine running, never use air or electric power tools or strike near the sensor(s) with a hammer. Heavy vibration could activate the sensor(s) and deploy the air bag(s), possibly causing serious injury.
- When using air or electric power tools or hammers, always switch the ignition OFF, disconnect the battery, and wait at least 3 minutes before performing any service.

#### Precautions for Removing Battery Terminal

INFOID:000000011325249

- When removing the 12V battery terminal, turn OFF the ignition switch and wait at least 30 seconds.

#### **NOTE:**

ECU may be active for several tens of seconds after the ignition switch is turned OFF. If the battery terminal is removed before ECU stops, then a DTC detection error or ECU data corruption may occur.

- For vehicles with the 2-batteries, be sure to connect the main battery and the sub battery before turning ON the ignition switch.

#### **NOTE:**

If the ignition switch is turned ON with any one of the terminals of main battery and sub battery disconnected, then DTC may be detected.

- After installing the 12V battery, always check "Self Diagnosis Result" of all ECUs and erase DTC.

#### **NOTE:**

The removal of 12V battery may cause a DTC detection error.

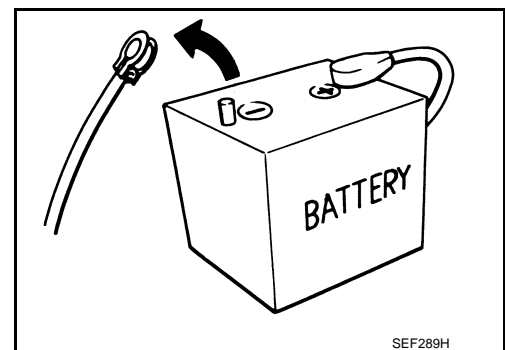

SEF289H

#### Precautions For Xenon Headlamp Service

INFOID:000000011544125

#### **WARNING:**

Comply with the following warnings to prevent any serious accident.

# PRECAUTIONS

## < PRECAUTION >

- **Disconnect the battery cable (negative terminal) or the power supply fuse before installing, removing, or touching the xenon headlamp (bulb included). The xenon headlamp contains high-voltage generated parts.**
- **Never work with wet hands.**
- **Check the xenon headlamp ON-OFF status after assembling it to the vehicle. Never turn the xenon headlamp ON in other conditions. Connect the power supply to the vehicle-side connector. (Turning it ON outside the lamp case may cause fire or visual impairments.)**
- **Never touch the bulb glass immediately after turning it OFF. It is extremely hot.**

### **CAUTION:**

Comply with the following cautions to prevent any error and malfunction.

- **Install the xenon bulb securely. (Insufficient bulb socket installation may melt the bulb, the connector, the housing, etc. by high-voltage leakage or corona discharge.)**
- **Never perform HID circuit inspection with a tester.**
- **Never touch the xenon bulb glass with hands. Never put oil and grease on it.**
- **Dispose of the used xenon bulb after packing it in thick vinyl without breaking it.**
- **Never wipe out dirt and contamination with organic solvent (thinner, gasoline, etc.).**

## Service Notice

INFOID:0000000011325250

- When removing or installing various parts, place a cloth or padding onto the vehicle body to prevent scratches.
- Handle trim, molding, instruments, grille, etc. carefully during removing or installing. Be careful not to oil or damage them.
- Apply sealing compound where necessary when installing parts.
- When applying sealing compound, be careful that the sealing compound never protrudes from parts.
- When replacing any metal parts (for example body outer panel, members, etc.), always take rust prevention measures.

## Precaution for Work

INFOID:0000000011325251

- When removing or disassembling each component, be careful not to damage or deform it. If a component may be subject to interference, always protect it with a shop cloth.
- When removing (disengaging) components with a screwdriver or similar tool, always wrap the component with a shop cloth or vinyl tape to protect it.
- Protect the removed parts with a shop cloth and keep them.
- Replace a deformed or damaged clip.
- If a part is specified as a non-reusable part, always replace it with new one.
- Always tighten bolts and nuts securely to the specified torque.
- After reinstallation is complete, always check that each part works normally.
- Follow the steps below to clean components.
  - Water soluble foul: Dip a soft cloth into lukewarm water, and wring the water out of the cloth to wipe the fouled area.  
Then rub with a soft and dry cloth.
  - Oily foul: Dip a soft cloth into lukewarm water with mild detergent (concentration: within 2 to 3%), and wipe the fouled area.  
Then dip a cloth into fresh water, and wring the water out of the cloth to wipe the detergent off. Then rub with a soft and dry cloth.
- Never use organic solvent such as thinner, benzene, alcohol, and gasoline.
- For genuine leather seats, and use a genuine leather seat cleaner.

# PREPARATION

< PREPARATION >

## PREPARATION

### PREPARATION

#### Special Service Tool

INFOID:000000011325252

The actual shapes of Kent-Moore tools may differ from those of special service tools illustrated here.

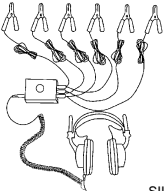
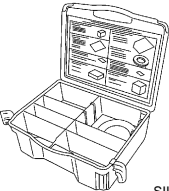
Tool number (Kent-Moore No.) Tool name	Description
<p>(J39570) Chassis ear</p>  <p style="text-align: right;">SIIA0993E</p>	<p>Locates the noise</p>
<p>(J50397) NISSAN Squeak and Rattle Kit</p>  <p style="text-align: right;">SIIA0994E</p>	<p>Repairs the cause of noise</p>

#### Commercial Service Tool

INFOID:000000011325253

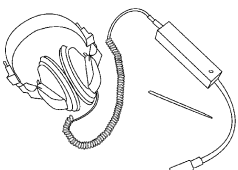
Tool name	Description
<p>Engine ear</p>  <p style="text-align: right;">SIIA0995E</p>	<p>Locates the noise</p>

# CLIP LIST

< PREPARATION >

## CLIP LIST

### Clip List

INFOID:000000011325254

Shapes	Removal & Installation	Shapes	Removal & Installation
	<p><b>Removal:</b> Remove by bending up with flat-bladed screwdrivers or clip remover.</p>	<p>Clip A Clip B</p>	<p><b>Removal:</b></p> <p>Finisher Clip A Flat-bladed screwdriver Clip B</p>
	<p><b>Removal:</b> Remove with a clip remover.</p>	<p>Clip A Clip B (Grommet)</p>	<p><b>Removal:</b></p> <p>Flat-bladed screwdriver Finisher Body panel Clip A Clip B (Grommet)</p>
	<p><b>Removal:</b> Push center pin to catching position. (Do not remove center pin by hitting it.)</p> <p>Push</p> <p><b>Installation:</b></p> <p>Push</p>		<p><b>Removal:</b> Holder portion of clip must be spread out to remove rod.</p>
	<p><b>Removal:</b> Remove by bending up with flat-bladed screwdrivers or clip remover.</p> <p>Clip Finisher</p>		<p><b>Removal:</b></p> <ol style="list-style-type: none"> <li>Screw out with a Phillips screwdriver.</li> <li>Remove female portion with flat-bladed screwdriver.</li> </ol>
	<p><b>Removal:</b></p>		<p><b>Removal:</b></p> <p>Rotate 45° to remove.</p> <p><b>Installation:</b></p>
	<p><b>Removal:</b></p>		<p><b>Removal:</b></p>

JMJIA3734GB

A  
B  
C  
D  
E  
F  
G  
H  
I  
SE  
K  
L  
M  
N  
O  
P

# COMPONENT PARTS

< SYSTEM DESCRIPTION >

## SYSTEM DESCRIPTION

### COMPONENT PARTS

#### POWER SEAT SYSTEM

#### POWER SEAT SYSTEM : Component Parts Location

INFOID:000000011325255

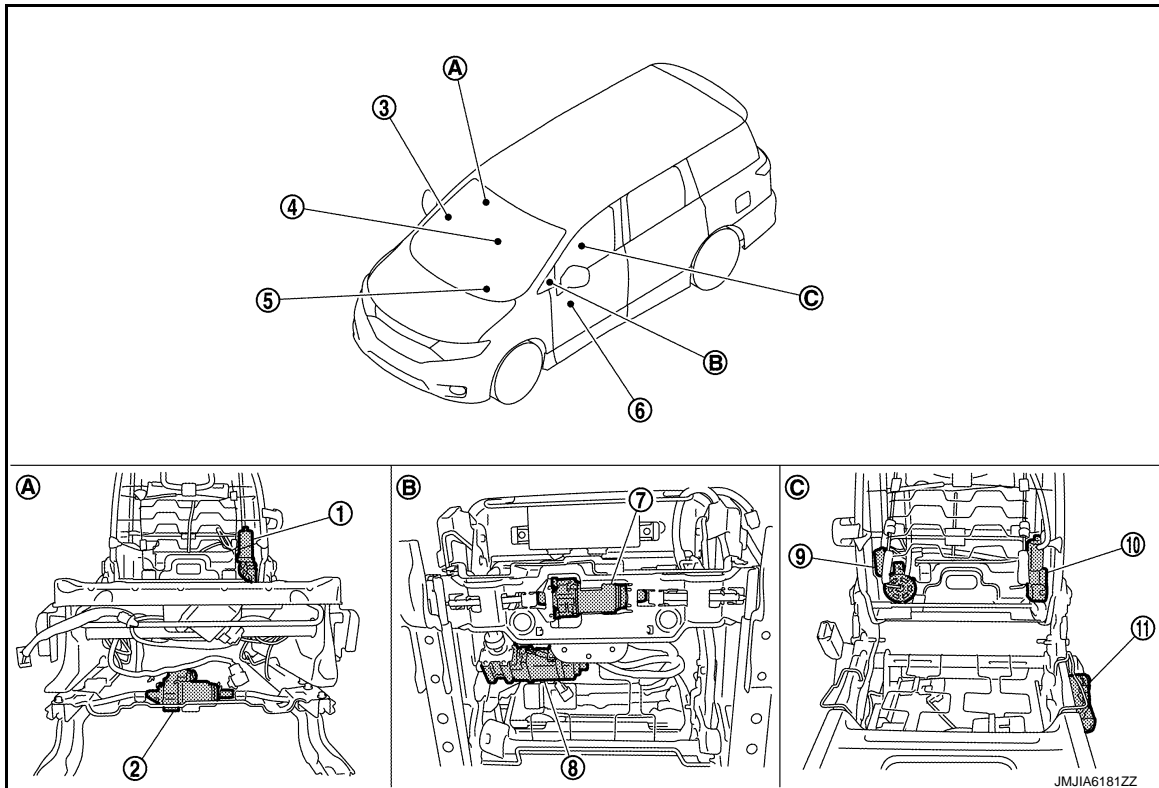

A. View with seatback pad removed (passenger side).

B. Back side of seat cushion.

C. View with seatback pad removed (driver side).

No.	Item	Function
1.	Reclining motor (passenger side)	Refer to <a href="#">SE-11, "Reclining Motor"</a> .
2.	Sliding motor (passenger side)	Refer to <a href="#">SE-11, "Sliding Motor"</a> .
3.	Power seat switch (passenger side)	Refer to <a href="#">SE-11, "Power Seat Switch"</a> .
4.	Lumbar support switch	Refer to <a href="#">SE-11, "Lumbar Support Switch"</a> .
5.	BCM	Supplies at all times the power received from battery to power seat switch. Refer to <a href="#">BCS-4, "BODY CONTROL SYSTEM : Component Parts Location"</a> .
6.	Power seat switch (driver side)	Refer to <a href="#">SE-11, "Power Seat Switch"</a> .
7.	Sliding motor (driver side)	Refer to <a href="#">SE-11, "Sliding Motor"</a> .
8.	Lifting motor (front)	Refer to <a href="#">SE-11, "Lifting Motor"</a> .
9.	Lumbar support motor	Refer to <a href="#">SE-11, "Lumbar Support Motor"</a> .
10.	Reclining motor	Refer to <a href="#">SE-11, "Reclining Motor"</a> .
11.	Lifting motor (front)	Refer to <a href="#">SE-11, "Lifting Motor"</a> .

#### HEATED SEAT SYSTEM



# COMPONENT PARTS

< SYSTEM DESCRIPTION >

## HEATED SEAT SYSTEM : Component Parts Location

INFOID:000000011325256

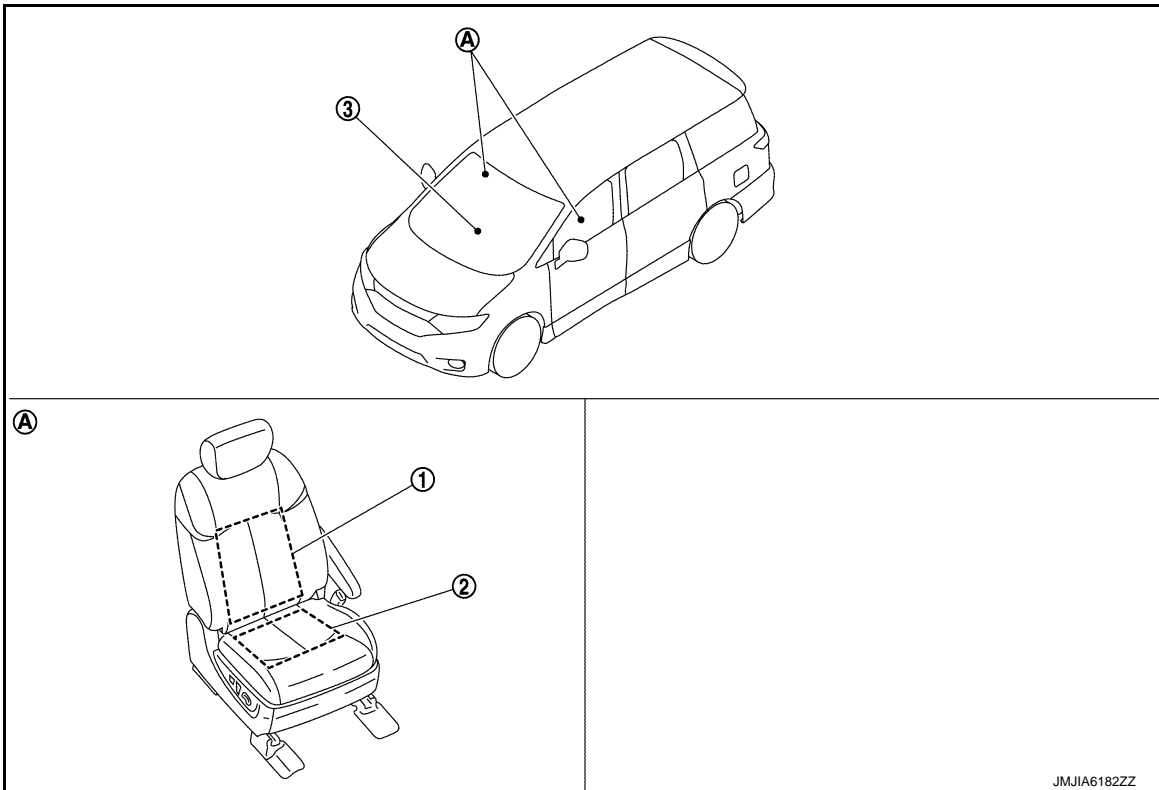

A. Front seat

No.	Item	Function
1.	Seat back heater	Refer to <a href="#">SE-11, "Seatback Heater"</a> .
2.	Seat cushion heater	Refer to <a href="#">SE-11, "Seat Cushion Heater"</a> .
3.	Heated seat switch	Refer to <a href="#">SE-11, "Heated Seat Switch"</a> .

## SEATBACK POWER FOLDING/RETURN SYSTEM

A  
B  
C  
D  
E  
F  
G  
H  
I  
SE  
K  
L  
M  
N  
O  
P

# COMPONENT PARTS

< SYSTEM DESCRIPTION >

## SEATBACK POWER FOLDING/RETURN SYSTEM : Component Parts Location

INFOID:000000011325257

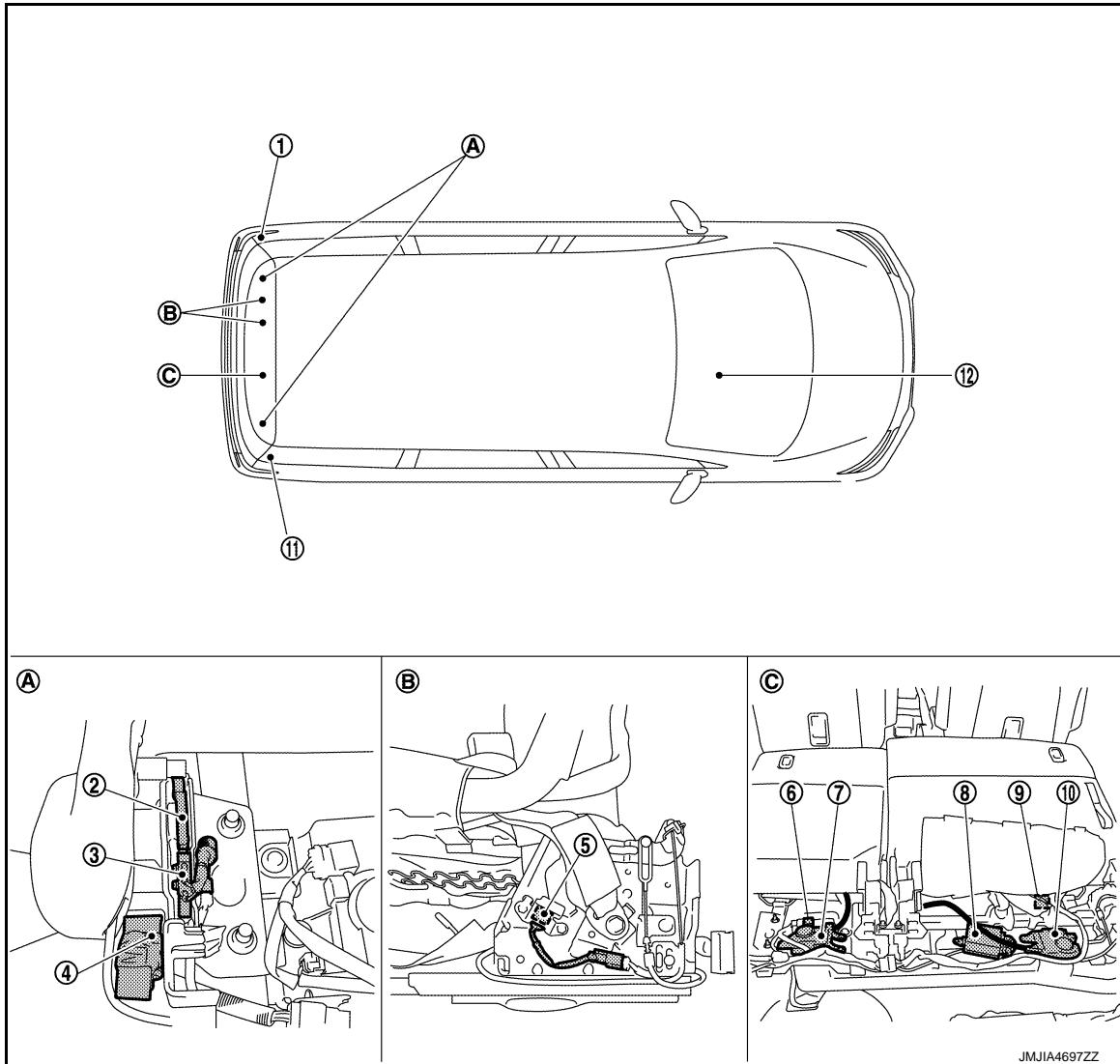

A. Reclining device assembly (outside) B. Reclining device assembly (Inside) C. Under the third seat

No.	Item	Function
1.	Third seat fold switch (LH)	Refer to <a href="#">SE-11, "Third Seat Fold Switch"</a> .
2.	Sector gear	Refer to <a href="#">SE-11, "Sector Gear"</a> .
3.	Sector gear position limit switch	Refer to <a href="#">SE-11, "Sector Gear Position Limit Switch"</a> .
4.	Power return motor assembly	Refer to <a href="#">SE-11, "Power Return Motor Assembly"</a> .
5.	Seatback angle limit switch	Refer to <a href="#">SE-11, "Seatback Angle Limit Switch"</a> .
6.	Seatback lock release actuator relay (LH)	Refer to <a href="#">SE-11, "Seatback Lock Release Actuator Relay"</a> .
7.	Seatback lock release actuator (LH)	Refer to <a href="#">SE-11, "Seatback Lock Release Actuator"</a> .
8.	Seatback power return control unit	Refer to <a href="#">SE-12, "Seatback Power Return Control Unit"</a> .
9.	Seatback lock release actuator relay (RH)	Refer to <a href="#">SE-11, "Seatback Lock Release Actuator Relay"</a> .
10.	Seatback lock release actuator (RH)	Refer to <a href="#">SE-11, "Seatback Lock Release Actuator"</a> .
11.	Third seat fold switch (RH)	Refer to <a href="#">SE-11, "Third Seat Fold Switch"</a> .
12.	Combination meter	Transmit the vehicle speed signal. Refer to <a href="#">MWI-7, "METER SYSTEM : Combination Meter"</a> .

## COMPONENT PARTS

### < SYSTEM DESCRIPTION >

<b>Reclining Motor</b>	INFOID:0000000011325258	A
With the power supplied from power seat switch, operates the forward and backward movement of seatback.		
<b>Sliding Motor</b>	INFOID:0000000011325259	B
With the power supplied from power seat switch, operates the forward and backward slide of seat.		
<b>Power Seat Switch</b>	INFOID:0000000011325260	C
Built-in reclining switch and sliding switch, controls the power supplied to each motor.		
<b>Lumbar Support Switch</b>	INFOID:0000000011325261	D
Controls the power supplied to lumbar support motor.		
<b>Lifting Motor</b>	INFOID:0000000011325262	E
With the power supplied from power seat switch, operates the up and down movement of seat cushion.		
<b>Lumbar Support Motor</b>	INFOID:0000000011325263	F
With the power supplied from lumbar support switch, operates the forward and backward movement of seat-back support device.		
<b>Seatback Heater</b>	INFOID:0000000011325264	G
Built-in seatback, the heater operates with the power supplied by heater seat switch.		
<b>Seat Cushion Heater</b>	INFOID:0000000011325265	H
Built-in seat cushion, the heater operates with the power supplied by heater seat switch.		
<b>Heated Seat Switch</b>	INFOID:0000000011325266	I
Supplies power supply to each heated seat and operates switching of HI/LO of heated seat and ON/OFF of the system.		SE
<b>Third Seat Fold Switch</b>	INFOID:0000000011325267	K
Supplies power supply to seatback lock release actuator relay and operates reclining and folding function of third seat.		
<b>Sector Gear</b>	INFOID:0000000011325268	L
Built-in reclining switch, sliding switch and lifting switch, controls the power supplied to each motor.		
<b>Sector Gear Position Limit Switch</b>	INFOID:0000000011325269	M
With the power supplied from power seat switch, operates the forward and backward movement of seatback.		
<b>Power Return Motor Assembly</b>	INFOID:0000000011325270	N
With the power supplied from power seat switch, operates the forward and backward slide of seat.		
<b>Seatback Angle Limit Switch</b>	INFOID:0000000011325271	O
With the power supplied from power seat switch, operates the up and down movement of seat cushion.		
<b>Seatback Lock Release Actuator Relay</b>	INFOID:0000000011325272	P
Supplies battery power supply to motor when receiving power supply from third seat fold down switch.		
<b>Seatback Lock Release Actuator</b>	INFOID:0000000011325273	
Releases lock when receiving battery power supply from seatback lock release actuator relay.		

## COMPONENT PARTS

< SYSTEM DESCRIPTION >

---

### Seatback Power Return Control Unit

INFOID:000000011325274

Control the seatback power return system.

# SYSTEM

< SYSTEM DESCRIPTION >

## SYSTEM

### POWER SEAT SYSTEM

#### POWER SEAT SYSTEM : System Description

INFOID:0000000011325275

Power seat switch can be operated regardless of the ignition switch position, because power supply is always supplied to power seat switch.

#### SLIDING OPERATION

While operating the sliding switch located in power seat switch, sliding motor operates and makes possible the seat front and back position adjustment.

#### RECLINING OPERATION

While operating the reclining switch located in power seat switch, reclining motor operates and makes possible the seat back forward and backward position adjustment.

#### LIFTING OPERATION

While operating the lifting switch located in power seat switch, lifting motor operates and makes possible the seat cushion up and down position adjustment.

#### LUMBAR SUPPORT

While operating the lumbar support switch, lumbar support motor operates which allows forward and backward operation of seatback support.

## HEATED SEAT SYSTEM

#### HEATED SEAT SYSTEM : System Description

INFOID:0000000011325276

Heated seat is a system that operates when ignition switch is in ON position.

#### HEATER OPERATION

- While operating the heated seat switch, seat cushion heater and seat back heater operate.
- Temperature of seat can be adjusted by operating on heated seat switch.

## SEATBACK POWER FOLDING/RETURN SYSTEM

#### SEATBACK POWER FOLDING/RETURN SYSTEM : System Description

INFOID:0000000011325277

#### SYSTEM DIAGRAM

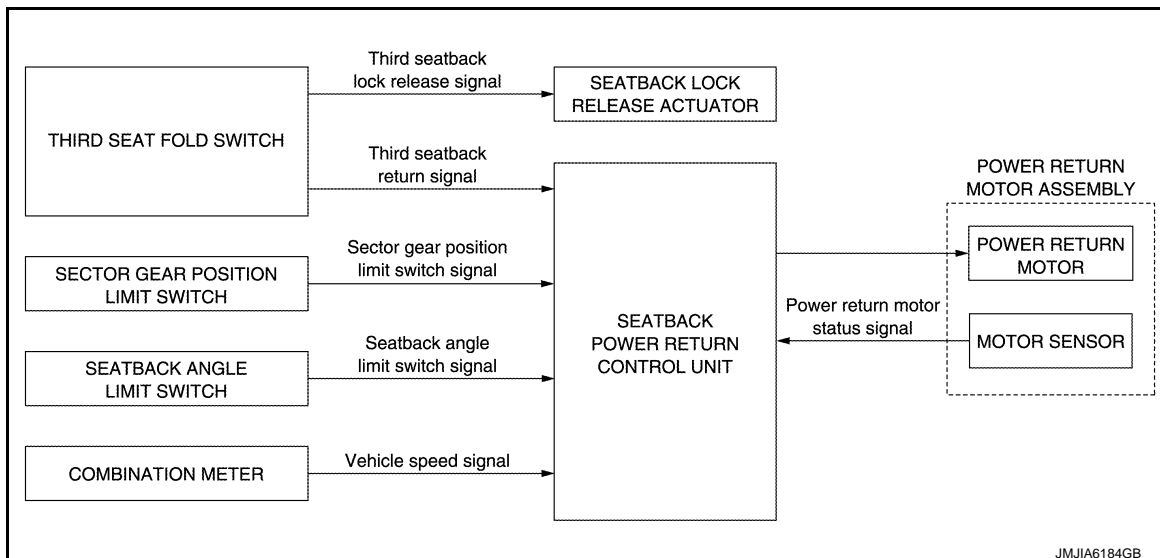

#### DESCRIPTION

Seatback power folding/return system (electric return type) consists of seatback power return control unit (buzzer is integrated), third seat fold switch, power return motor (motor sensor is integrated), sector gear position limit switch, seatback angle limit switch, and sector gear that transfers the movement of power return

# SYSTEM

## < SYSTEM DESCRIPTION >

motor. The seatback LH and RH of third seat can be folded up or down independently according to the operation of third seat fold switch in luggage room.

### Operation Condition

Seatback power folding/return operation (electric type) starts when all of the following conditions are satisfied.

- Vehicle speed 2 km/h (1 MPH) or less
- Seatback angle limit switch is ON
- Battery voltage is normal

### Seatback Power Fold/Return Operation

When third seat fold switch is operated, seatback power return control units checks whether or not the operation conditions are satisfied, and then controls the return operation of third seatback.

Status of each part is as described in the following table.

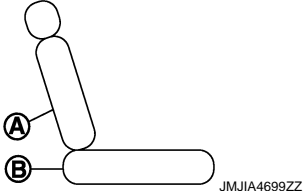
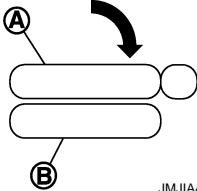
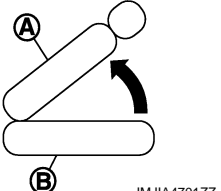
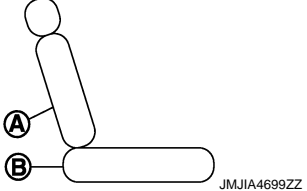
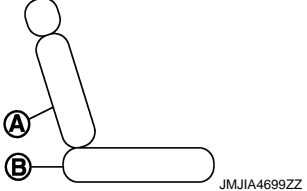
No.	Third seatback condition	Sector gear position	Sector gear position switch	Seatback angle limit switch
1	Return complete position  A: Third seatback B: Seat cushion	Initial position	OFF	OFF
2	Fold down position  A: Third seatback B: Seat cushion	Initial position	OFF	ON
3	Return operation  A: Third seatback B: Seat cushion	Return incomplete position	OFF → ON	ON
4	Return complete position  A: Third seatback B: Seat cushion	Return complete position	ON	OFF
5	Return complete position  A: Third seatback B: Seat cushion	Initial position	OFF	OFF

1. When third seatback is in folded up status (return complete position), sector gear is in the initialization position. Sector gear position limit switch and seatback angle limit switch are in the OFF position.
2. When third seat fold switch is pressed in the direction of folding down, seatback lock release actuator operates, winds wire of seatback lock assembly, and then releases seatback lock.  
When seatback lock is released, seatback folds down by repulsion of spring in seatback.

# SYSTEM

## < SYSTEM DESCRIPTION >

When third seatback folds down, seatback angle limit switch turns ON, and seatback power return control unit judges that third seatback is in the folded down status (folding down position).

3. When third seat fold switch is pressed in the direction of folding up, seatback power return control unit supplies power supply to power return motor and sounds return operation start buzzer.

Power return motor, which is supplied power from seatback power return control unit, rotates to the folding up direction, and operates third seat return operation via sector gear.

When sector gear starts to rotate in the folding up direction, sector gear position limit switch turns ON, and seatback power return control unit judges that sector gear is in a position other than the initial position.

4. When third seat folds up to the return complete position, seatback angle limit switch turns OFF, and seatback power return control unit sounds return completion buzzer and stops power return motor.

When power return motor is stopped, after 0.2 seconds, seatback power return control unit rotates power return motor in the reverse direction so that sector gear returns to the initial position.

5. When sector gear returns to the initial position according to the reverse rotation of power return motor, sector gear position limit switch turns OFF and seatback power return control unit stops the reverse rotation of power return motor, and the return operation is complete.

### NOTE:

- When third seat fold switch is released during return operation (sector gear position limit switch and seatback angle limit switch are in the ON position), seatback power return control unit detects third seat fold switch OFF signal, rotates power return motor in the reverse direction, and then returns third seatback to the folded down position.

When third seat fold switch is pressed again during reverse operation, return operation restarts.

- When battery cable is disconnected from battery terminal while sector gear is in a position other than the initial position (sector gear position limit switch is in the ON position), and then when battery cable is connected again to battery terminal, sector gear returns to the initial position.

### Anti-Pinch Function

When signal change from motor sensor is detected during third seatback return operation, due to foreign material trapping, seatback power return control unit sounds buzzer, stops power return motor, and rotates power return motor in the reverse direction after 0.2 seconds. Third seatback returns to the folded down position.

### Sector Gear Reverse Starting Condition

Sector gear rotates in the reverse direction when any of the following conditions is satisfied.

- Third seatback return operation is complete (seatback angle limit switch: OFF)
- Third seat fold switch is released before return operation is complete
- Trapping is detected
- Lock status of power return motor is detected
- Third seatback return operation is not complete within 60 seconds
- Battery voltage malfunction is detected during return operation
- Battery voltage returns to normal after battery voltage malfunction is detected during return operation
- Sector gear position limit switch does not turn from OFF to ON within the specified number of times of motor pulse from the start of return operation

The reverse rotation operation stops when any of the following conditions is satisfied.

- Sector gear initial position (sector gear position limit switch: OFF)
- Lock status of power return motor is detected (lock during reverse rotation operation)
- The sector gear initial position is not completed within 60 seconds

### Consumption Electricity Control System

Seatback power return control unit controls electric power so that electric power consumption can be reduced according to the vehicle condition.

### Low Electric Power Consumption Mode

The system shifts to low electric power consumption mode when all the following conditions are satisfied.

- Third seat fold switch is OFF
  - Power return motor is not in operation
  - When the condition that the vehicle speed is 2 km/h (1 MPH) or less continues for 30 seconds or more
- The system releases low electric power consumption mode when any of the following conditions is satisfied.
- When third seat fold switch is pressed
  - When the change occurs to the pulse of vehicle speed sensor

For low electric power consumption mode, the following functions are available.

- Power supply for sector gear position limit switch and seatback angle limit switch is turned OFF
- Power supply for motor sensor is turned OFF when power return motor is not in operation

# SYSTEM

## < SYSTEM DESCRIPTION >

### Buzzer Operation Pattern And Order Priority

Seatback power return control unit sounds a buzzer according to third seatback return operation status. When buzzer sounding conditions are satisfied at the same time, the highest buzzer pattern are as described in the following table.

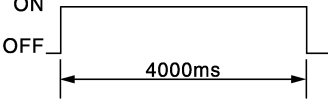
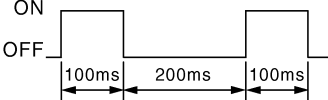
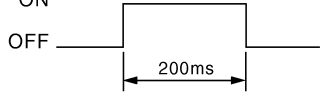
Operation type	Sound pattern	Priority
Malfunction	 <p style="text-align: center; font-size: small;">JM/JIA1396ZZ</p>	1
Return operation completed	 <p style="text-align: center; font-size: small;">JM/JIA1395ZZ</p>	2
Start return operation	 <p style="text-align: center; font-size: small;">JM/JIA1394ZZ</p>	3



# SYSTEM

< SYSTEM DESCRIPTION >

## SEATBACK POWER FOLDING/RETURN SYSTEM : Circuit Diagram

INFOID:000000011325278

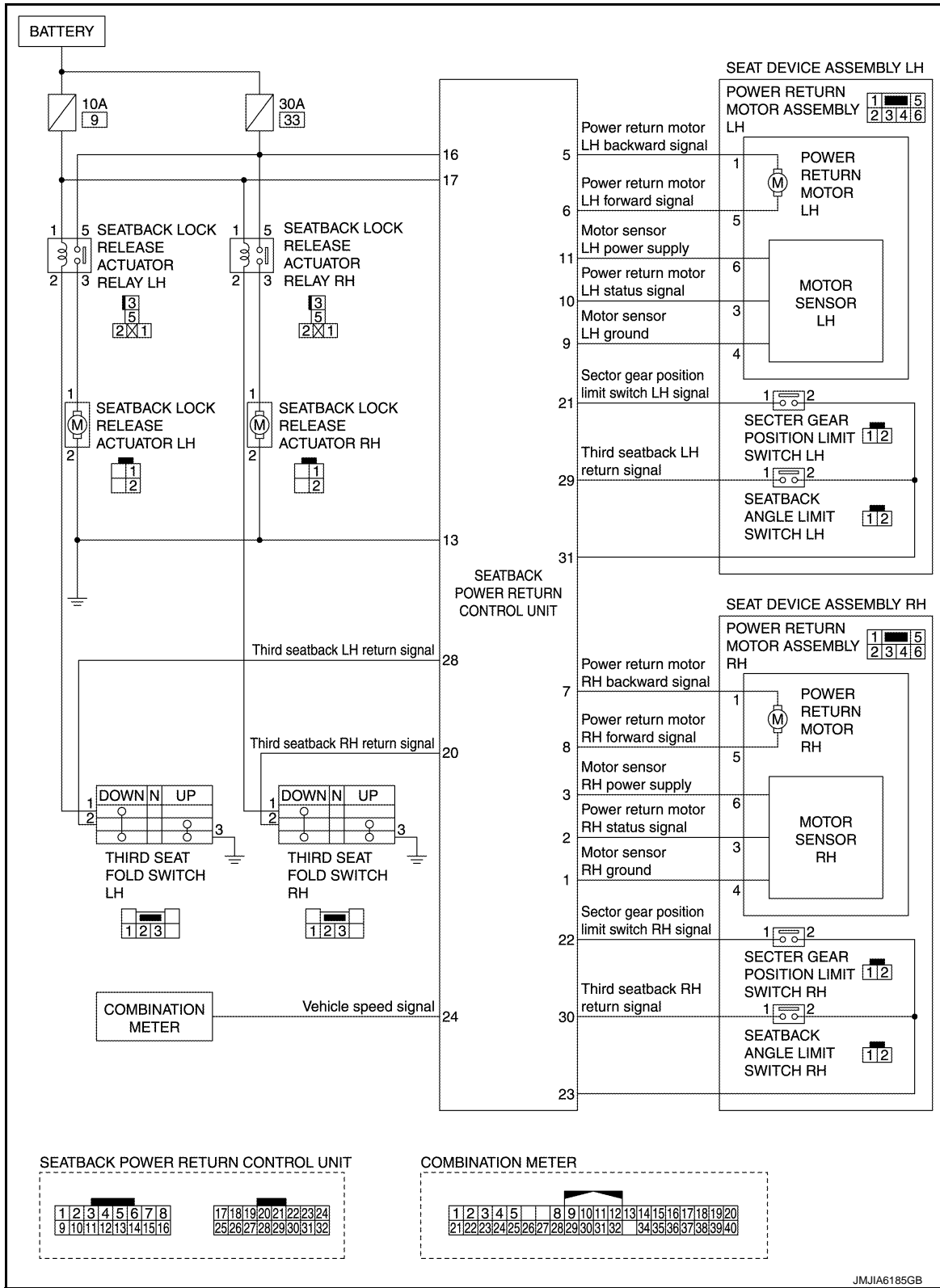

A  
B  
C  
D  
E  
F  
G  
H  
I  
SE  
K  
L  
M  
N  
O  
P

## SEATBACK POWER FOLDING/RETURN SYSTEM : Fail-safe

INFOID:000000011325279

Even if the automatic return control is inactivated, the fold-down and manual return operations can be performed.

# SYSTEM

## < SYSTEM DESCRIPTION >

Malfunction items	Fail-safe in operation
Seatback angle limit switch stays in the "ON" position	Seatback power return control unit judges that power return motor and gear are locked during operation because the return complete position of third seatback cannot be recognized. Seatback power return control unit operates power return motor in the reverse rotation.
Seatback angle limit switch stays in the "OFF" position	Seatback power return control unit recognizes that third seatback is in the return complete position. Third seatback does not operate when third seat fold switch is operated in the following up direction.
Sector gear position limit switch stays in the "ON" position	Seatback power return control unit recognized that sector gear is locked during operation and stops power motor operation. Operation of seatback power return system is inhibited when the above status is recognized continuously 4 times.
Sector gear position limit switch stays in the "OFF" position	When sector gear position limit switch does not turn ON after seatback power return operation is started, seatback power return control unit judges that sector gear is locked and operates power return motor in the reverse operation.
Motor sensor malfunction (High, Low, or Fixed)	When pulse does not indicate any change after motor starts to operate, seatback power return control unit judges that motor sensor is malfunctioning and returns sector gear to the initial position.

# SEATBACK POWER RETURN CONTROL UNIT

< ECU DIAGNOSIS INFORMATION >

## ECU DIAGNOSIS INFORMATION

### SEATBACK POWER RETURN CONTROL UNIT

Reference Value

INFOID:0000000011325280

#### TERMINAL LAYOUT

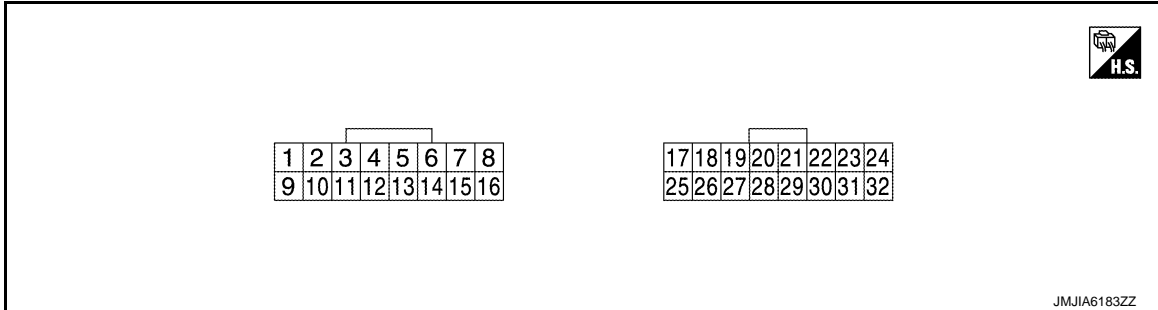

#### PHYSICAL VALUES

Terminal No. (Wire color)		Description		Condition	Value
(+)	(-)	Signal name	Input/ Output		
1 (B/W)	Ground	Ground [Motor sensor (RH)]	—	—	—
2 (R)	Ground	Motor sensor (RH) input signal	Input	When the power return motor (RH) is operated	 JMkia0070GB
				When the pinch occurs	The above pulse width should be expanded
3 (R/B)	Ground	Power supply [Motor sensor (RH)]	Output	When the power return motor is oper- ated	9 – 16 V
5 (L/W)	Ground	Power return motor (LH) backward signal	Output	When the power return motor (LH) performs reverse operation	9 – 16 V
				Other than the above	0 – 0.5 V
6 (Y)	Ground	Power return motor (LH) forward signal	Output	When the power return motor (LH) performs return operation	9 – 16 V
				Other than the above	0 – 0.5 V
7 (G)	Ground	Power return motor (RH) backward signal	Output	When the power return motor (RH) performs reverse operation	9 – 16 V
				Other than the above	0 – 0.5 V
8 (B/Y)	Ground	Power return motor (RH) forward signal	Output	When the power return motor (RH) performs return operation	9 – 16 V
				Other than the above	0 – 0.5 V
9 (R/W)	Ground	Ground [Motor sensor (LH)]	—	—	—

# SEATBACK POWER RETURN CONTROL UNIT

## < ECU DIAGNOSIS INFORMATION >

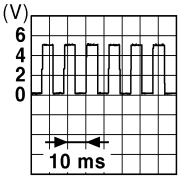
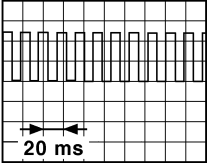
Terminal No. (Wire color)		Description		Condition	Value
(+)	(-)	Signal name	Input/ Output		
10 (L/W)	Ground	Motor sensor (LH) input signal	Input	When the power return motor (LH) is operated	 JMKIA0070GB
				When the pinch occurs	The above pulse width should be expanded
11 (Y/R)	Ground	Power supply [Motor sensor (LH)]	Output	When the power return motor is operated	9 – 16 V
13 (G/W)	Ground	Ground	—	—	—
16 (B/W)	Ground	Battery power supply	Input	—	9 – 16 V
17 (LG)	Ground	System power supply	Input	—	9 – 16 V
20 (Y)	Ground	Third seat fold switch (RH)	Input	Third seat fold switch (RH) in return position	0 – 0.5 V
				Other than the above	4.7 – 5.3 V
21 (B/W)	Ground	Sector gear position limit switch (LH) input signal	Input	When the sector gear (LH) is in the initial position (other than low power consumption mode)	9 – 16 V
				Other than the above	0 – 0.5 V
22 (SB)	Ground	Sector gear position limit switch (RH) input signal	Input	When the sector gear (RH) is in the initial position (other than low power consumption mode)	9 – 16 V
				Other than the above	0 – 0.5 V
23 (B/O)	Ground	Ground [Limit switch (RH)]	—	—	—
24 (L/O)	Ground	Vehicle speed signal	Input	When vehicle speed is approx.40 km/h (25MPH)	 JSNIA0012GB
28 (G/O)	Ground	Third seat fold switch (LH)	Input	Third seat fold switch (LH) in return position	0 – 0.5 V
				Other than the above	4.7 – 5.3 V
29 (O)	Ground	Seatback angle limit switch (LH) input signal	Input	When the third seatback (LH) is in the return completion position (other than low power consumption mode)	9 – 16 V
				Other than the above	0 – 0.5 V
30 (BR/W)	Ground	Seatback angle limit switch (RH) input signal	Input	When the third seatback (RH) is in the return completion position (other than low power consumption mode)	9 – 16 V
				Other than the above	0 – 0.5 V

# SEATBACK POWER RETURN CONTROL UNIT

## < ECU DIAGNOSIS INFORMATION >

Terminal No. (Wire color)		Description		Condition	Value
(+)	(-)	Signal name	Input/ Output		
31 (W/R)	Ground	Ground [Limit switch (LH)]	—	—	—
32 (L/W)	Ground	Ground	—	—	—

### Fail-safe

INFOID:0000000011325281

Even if the automatic return control is inactivated, the fold-down and manual return operations can be performed.

Malfunction items	Fail-safe in operation
Seatback angle limit switch stays in the "ON" position	Seatback power return control unit judges that power return motor and gear are locked during operation because the return complete position of third seatback cannot be recognized. Seatback power return control unit operates power return motor in the reverse rotation.
Seatback angle limit switch stays in the "OFF" position	Seatback power return control unit recognizes that third seatback is in the return complete position. Third seatback does not operate when third seat fold switch is operated in the following up direction.
Sector gear position limit switch stays in the "ON" position	Seatback power return control unit recognized that sector gear is locked during operation and stops power motor operation. Operation of seatback power return system is inhibited when the above status is recognized continuously 4 times.
Sector gear position limit switch stays in the "OFF" position	When sector gear position limit switch does not turn ON after seatback power return operation is started, seatback power return control unit judges that sector gear is locked and operates power return motor in the reverse operation.
Motor sensor malfunction (High, Low, or Fixed)	When pulse does not indicate any change after motor starts to operate, seatback power return control unit judges that motor sensor is malfunctioning and returns sector gear to the initial position.

A  
B  
C  
D  
E  
F  
G  
H  
I  
K  
L  
M  
N  
O  
P

SE

# POWER SEAT CONTROL SYSTEM

< WIRING DIAGRAM >

## WIRING DIAGRAM

### POWER SEAT CONTROL SYSTEM

#### DRIVER SIDE

#### DRIVER SIDE : Wiring Diagram

INFOID:000000011325282

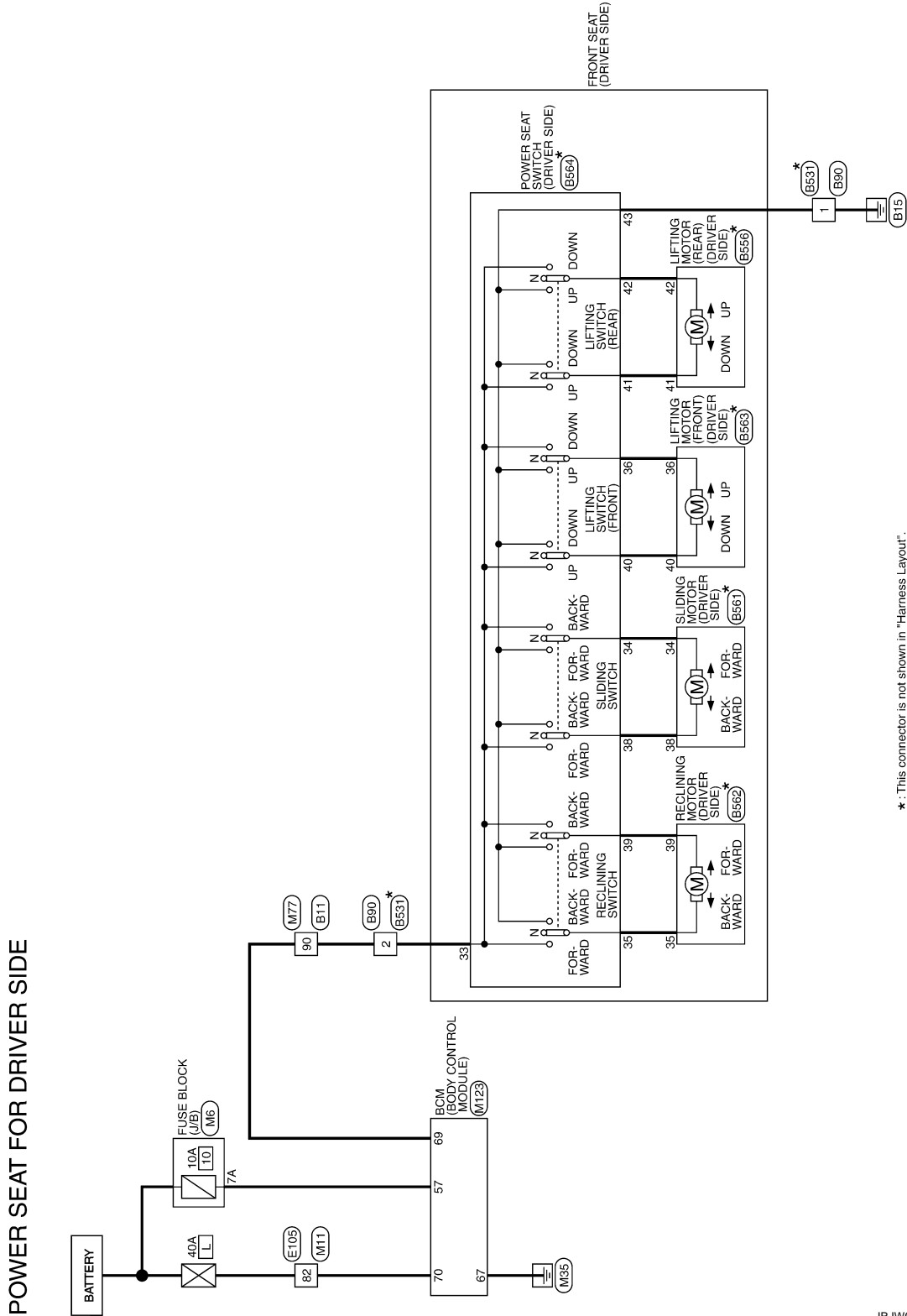

\* : This connector is not shown in "Harness Layout".

2014/07/25

JR.JWC8288GB

# POWER SEAT CONTROL SYSTEM

< WIRING DIAGRAM >

**POWER SEAT FOR DRIVER SIDE**

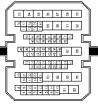

Connector No.	B511
Connector Name	WIRE TO WIRE
Connector Type	TH80MM-CST9

Terminal No.	Color Of Wire	Signal Name [Specification]
10	GR	-
12	G	-
13	B	-
15	L	-
29	GR	-
30	W	-
31	P	-
37	SHIELD	-
38	R	-
39	B	-
40	W	-
51	Y	-
52	B	-
53	G	-
54	P	-
57	Y	-
58	L	-
59	GR	-
60	Y	-
62	BR	-
63	L	-
64	W	-
65	R	-
66	SHIELD	-
67	B	-
68	W	-
69	SHIELD	-
70	GR	-
71	B/R	-
72	BR	-
74	L	-
75	S5	-
77	V	-



78	LG	-
79	BR	-
80	BR	-
81	SB	-
82	V	-
87	G	-
88	V	-
89	G	-
90	Y	-
91	LG	-
92	L	-

Connector No.	B50
Connector Name	WIRE TO WIRE
Connector Type	NS56FW-CS



Terminal No.	Color Of Wire	Signal Name [Specification]
1	B	-
2	L	-
4	LG	-
5	GR	-
6	LG	-

Connector No.	B531
Connector Name	WIRE TO WIRE
Connector Type	NS56MM-CS



Terminal No.	Color Of Wire	Signal Name [Specification]
1	LG	-
2	BR/W	-
4	Y	-
5	L/P	-
6	P	-

Connector No.	B556
Connector Name	LIFTING MOTOR (REAR) (DRIVER SIDE)
Connector Type	6098-2768



Terminal No.	Color Of Wire	Signal Name [Specification]
12	L/R	-
20	B/L	-
41	V	-
42	P/E	-
43	LG	-

Connector No.	B561
Connector Name	SLIDING MOTOR (DRIVER SIDE)
Connector Type	6098-3768

Terminal No.	Color Of Wire	Signal Name [Specification]
12	L/R	-
34	B	-
38	GR	-
43	LG	-

Connector No.	B562
Connector Name	RECLINING MOTOR (DRIVER SIDE)
Connector Type	1326490-3

Terminal No.	Color Of Wire	Signal Name [Specification]
35	G	-
39	Y	-

JRJWC8289GB

A  
B  
C  
D  
E  
F  
G  
H  
I  
SE  
K  
L  
M  
N  
O  
P

# POWER SEAT CONTROL SYSTEM

< WIRING DIAGRAM >

## POWER SEAT FOR DRIVER SIDE

Connector No.	B563
Connector Name	LIFTING MOTOR FRONT (DRIVER SIDE)
Connector Type	6086-0238



Terminal No.	Color Of Wire	Signal Name [Specification]
38	L	--
40	W	--

Connector No.	B564
Connector Name	POWER SEAT SWITCH (DRIVER SIDE)
Connector Type	NS10FM-CS



Terminal No.	Color Of Wire	Signal Name [Specification]
33	R	--
34	B	--
35	G	--
36	L	--
38	GR	--
39	Y	--
40	W	--
41	V	--
42	P/B	--
43	LG	--

Connector No.	E105
Connector Name	WIRE TO WIRE
Connector Type	TH10MW-CS10-M3



Terminal No.	Color Of Wire	Signal Name [Specification]
2	SHIELD	--
3	B	--
4	R	--
6	LG	--
7	R	--
8	GR	--
9	V	--
10	BR	--
11	Y	--
12	O	--
13	W	--
14	L	--
15	GR	--
16	GR	--
32	V	--
37	BR	--
38	G	--
39	V	--
40	P	--
41	L	--
42	LG	--
43	O	--
45	P	--
46	SB	--
47	V	--
49	L	--
51	BR	--
52	G	--
53	B	--
54	O	--
55	Y	--
56	SHIELD	--
61	P	--
62	G	--
63	W/L	--

Terminal No.	Color Of Wire	Signal Name [Specification]
64	W/R	--
66	W	--
67	Y	--
69	R	--
71	R	--
72	L	--
73	GR	--
74	Y	--
75	SB	--
76	Y	--
77	G	--
78	O	--
80	R	--
81	L	--
82	LG	--
83	R	--

Connector No.	ME
Connector Name	FUSE BLOCK (J/B)
Connector Type	CS50FM-M2



Terminal No.	Color Of Wire	Signal Name [Specification]
1A	Y	--
2A	G	--
3A	L	--
4A	GR	--
5A	V	--
6A	R	--
7A	GR	--
8A	L	--

Connector No.	M11
Connector Name	WIRE TO WIRE
Connector Type	TH10FM-CS10-M3



Terminal No.	Color Of Wire	Signal Name [Specification]
2	SHIELD	--
3	B	--
4	R	--
6	G	--
7	R	--
8	G	--
9	B	--
10	R	--
11	W	--
12	L	-- [Without automatic drive positioner]
12	LG	-- [With automatic drive positioner]
13	G	-- [Without automatic drive positioner]
13	Y	-- [With automatic drive positioner]
14	Y	--
15	P	--
31	R	--
32	LG	--
37	BR	-- [With automatic drive positioner]
37	W	-- [Without automatic drive positioner]
38	R	--
39	BE	-- [Without automatic drive positioner]
39	Y	-- [With automatic drive positioner]
40	P	--
41	L	--
42	G	--
43	W	--
43	P	--
47	V	--
49	G	--
49	O	--
51	G	--
52	W	--
53	B	--
54	LG	--
55	L	--



# POWER SEAT CONTROL SYSTEM

< WIRING DIAGRAM >

A  
B  
C  
D  
E  
F  
G  
H  
I  
SE  
K  
L  
M  
N  
O  
P

## POWER SEAT FOR DRIVER SIDE

86	SHIELD	-
87	R	-
88	B	-
89	W	-
90	W	-
91	BR	-
92	P	-
93	R	-
94	L	-
95	LG	-
96	Y	-
97	V	-
98	P	-
99	BR	-
100	W	-
101	L	-
102	LG	-
103	Y	-
104	V	-
105	P	-
106	BR	-
107	W	-
108	L	-
109	R	-

Connector No.	M17
Connector Name	WIRE TO WIRE
Connector Type	TH80PW-CS19

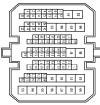

Terminal No.	Color Of Wire	Signal Name [Specification]
10	P	-
12	BE	-
13	W	-
15	R	-
29	W	-
30	P	-
31	BE	-
32	SHIELD	-
38	W	- [Without around view monitor]
39	B	- [With around view monitor]
39	W	- [Without around view monitor]
40	R	-
51	LG	-

Connector No.	M123
Connector Name	BCM (BODY CONTROL MODULE)
Connector Type	FE108FW-FM46-SA



Terminal No.	Color Of Wire	Signal Name [Specification]
54	P	INT ROOM LAMP PWR SPLY
54	P	DOOR LOCK
54	O	AIR BAG
55	SR	PASS DOOR UNLK OUTPUT
60	V	TURN SIG LH OUTPUT
61	G	TURN SIG RH OUTPUT
62	W	STEP LAMP CONT
63	R	INT ROOM LAMP CONT
64	W	CRANK REC
65	V	ALL DOOR LOCK OUTPUT
66	G	DR DOOR UNLK OUTPUT
67	B	GROUND
68	L	PW PWR SPLY (IGN)
69	P	PW PWR SPLY (BAT)
70	L	BAT

52	B	-
53	BE	-
54	R	-
55	L	-
57	Y	-
58	L	-
59	BE	-
60	G	-
61	LG	-
62	SB	-
63	BE	-
64	R	-
65	G	-
66	SHIELD	-
67	B	-
68	R	-
69	SHIELD	-
70	B	-
71	W	-
72	G	-
74	GR	-
75	G	-
77	W	-
78	R	-
79	W	-
80	G	-
81	L	-
82	W	-
87	V	-
88	CG	-
89	R	-
90	Y	- [With automatic drive positioner]
91	LG	- [Without automatic drive positioner]
92	BR	-

# POWER SEAT CONTROL SYSTEM

< WIRING DIAGRAM >

## PASSENGER SIDE : Wiring Diagram

INFOID:000000011325283

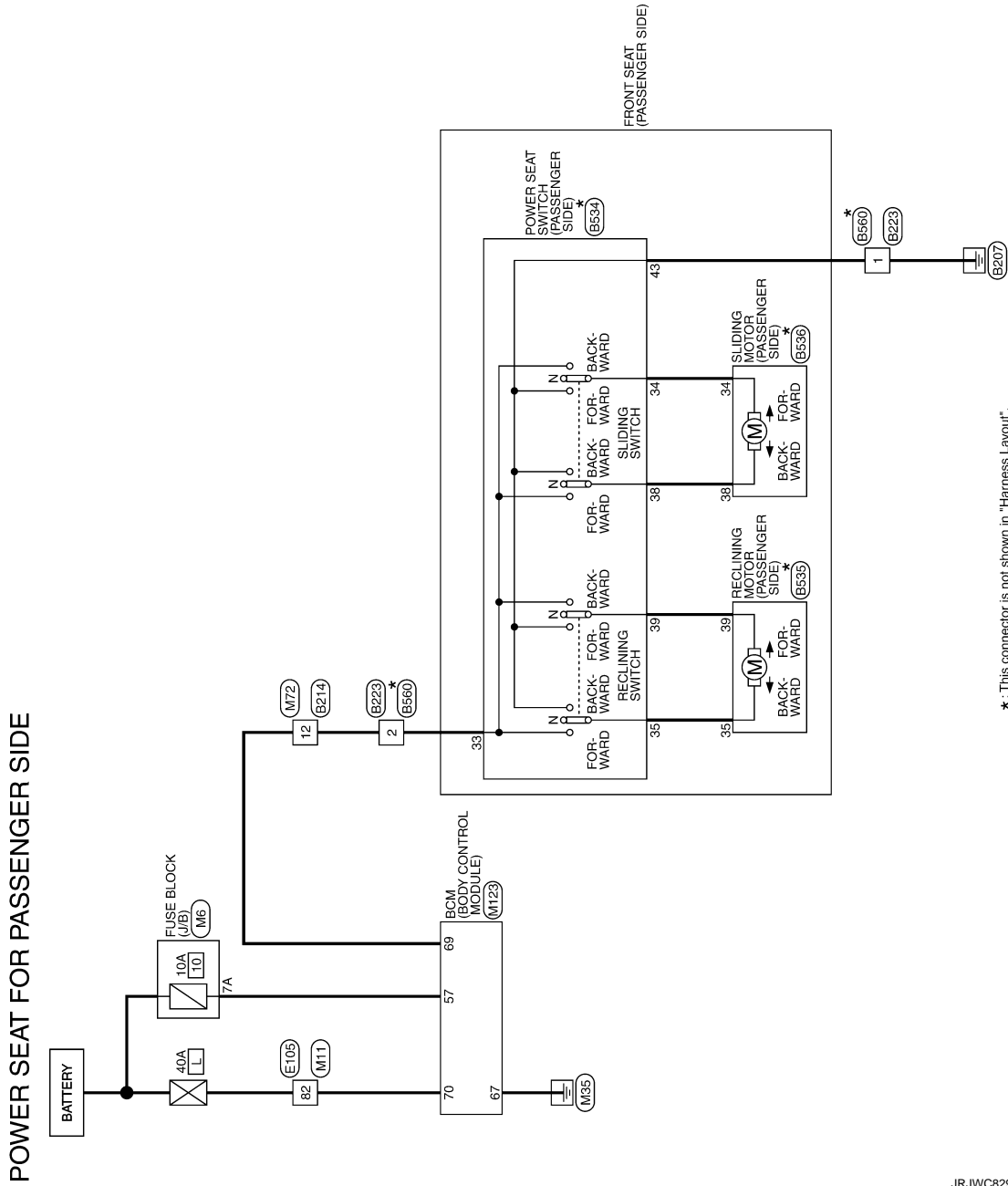

# POWER SEAT CONTROL SYSTEM

< WIRING DIAGRAM >

## POWER SEAT FOR PASSENGER SIDE

Connector No.	E214
Connector Name	WIRE TO WIRE
Connector Type	NS12MBR-CS



1	2	3	4	5
6	7	8	9	10
11	12			

Terminal No.	Color Of Wire	Signal Name [Specification]
1	SB	-
2	BR	-
3	Y	-
4	W	-
5	LG	-
6	R	-
7	GR	-
8	LG	-
9	Y	-
10	G	-
11	W	-
12	SB	-

Connector No.	E223
Connector Name	WIRE TO WIRE
Connector Type	NS08BW-CS



2	1
6	5
4	3

Terminal No.	Color Of Wire	Signal Name [Specification]
1	B	-
2	SB	-
3	BR	-
4	Y	-
5	W	-
6	G	-

Connector No.	E534
Connector Name	POWER SEAT SWITCH (PASSENGER SIDE)
Connector Type	NS10FW-CS



43	33
35	34
36	39

Terminal No.	Color Of Wire	Signal Name [Specification]
33	R	-
34	G	-
35	GR	-
36	Y	-
38	LG	-
43	LG	-

Connector No.	E535
Connector Name	RECLINING MOTOR (PASSENGER SIDE)
Connector Type	1128F40-3



43	39
----	----

Terminal No.	Color Of Wire	Signal Name [Specification]
35	G	-
39	Y	-

Connector No.	B536
Connector Name	SLIDING MOTOR (PASSENGER SIDE)
Connector Type	B698-3768



33	34
38	34

Terminal No.	Color Of Wire	Signal Name [Specification]
34	B	-
38	GR	-

Connector No.	B560
Connector Name	WIRE TO WIRE
Connector Type	NS08BW-CS



1	2
3	4
5	6

Terminal No.	Color Of Wire	Signal Name [Specification]
1	LG	-
2	R	-
3	BR/W	-
4	Y	-
5	L/P	-
6	P	-

Connector No.	E105
Connector Name	WIRE TO WIRE
Connector Type	TH10MW-CSD-403



1	2	3	4	5	6	7	8	9	10	11	12	13	14	15	16	17	18	19	20	21	22	23	24	25	26	27	28	29	30	31	32	33	34	35	36	37	38	39	40
---	---	---	---	---	---	---	---	---	----	----	----	----	----	----	----	----	----	----	----	----	----	----	----	----	----	----	----	----	----	----	----	----	----	----	----	----	----	----	----

Terminal No.	Color Of Wire	Signal Name [Specification]
1	SHIELD	-
2	W	-
3	W	-
4	R	-
6	LG	-
7	R	-
8	GR	-
9	V	-
10	BR	-
11	Y	-
12	O	-
13	W	-
14	L	-
15	P	-
31	GR	-
32	GR	-
37	BR	-
38	G	-
39	V	-
40	P	-
41	L	-
42	LG	-
43	O	-
45	P	-
46	SB	-
47	V	-
49	L	-
51	BR	-
52	G	-
54	D	-
55	Y	-
56	SHIELD	-
61	P	-
62	G	-

A  
B  
C  
D  
E  
F  
G  
H  
I  
SE  
K  
L  
M  
N  
O  
P

# POWER SEAT CONTROL SYSTEM

< WIRING DIAGRAM >

## POWER SEAT FOR PASSENGER SIDE

63	N	-	-
64	W	-	-
65	W	-	-
66	W	-	-
67	Y	-	-
68	R	-	-
69	R	-	-
70	R	-	-
71	R	-	-
72	L	-	-
73	GR	-	-
74	Y	-	-
75	SB	-	-
76	Y	-	-
77	G	-	-
78	O	-	-
80	R	-	-
81	L	-	-
82	LG	-	-
83	R	-	-

Connector No.	M6
Connector Name	FUSE BLOCK (J/B)
Connector Type	CS08FW-M2

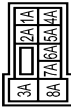

Terminal No.	Color Of Wire	Signal Name [Specification]
1A	Y	-
2A	G	-
3A	L	-
4A	GR	-
5A	V	-
6A	R	-
7A	GR	-
8A	L	-

Connector No.	M11
Connector Name	WIRE TO WIRE
Connector Type	TH10FW-CS10-M3

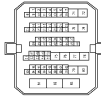

Terminal No.	Color Of Wire	Signal Name [Specification]
1	SHIELD	-
2	W	-
3	W	-
4	R	-
6	G	-
7	R	-
8	G	-
9	B	-
10	R	-
11	W	-
12	L	- [Without automatic drive positioner]
13	LG	- [With automatic drive positioner]
14	G	- [Without automatic drive positioner]
15	Y	- [With automatic drive positioner]
16	L	-
17	P	-
31	R	-
32	LG	-
37	BR	- [With automatic drive positioner]
38	W	- [Without automatic drive positioner]
39	BE	- [Without automatic drive positioner]
40	Y	- [With automatic drive positioner]
41	L	-
42	G	-
43	W	-
45	Y	-
46	Y	-
48	R	-
49	G	-
51	G	-
52	W	-
53	B	-
54	LG	-
55	L	-

56	SHIELD	-
61	W	-
62	W	-
63	B	-
64	W	-
66	W	-
67	BR	-
69	P	-
71	R	-
72	L	-
73	LG	-
74	Y	-
75	Y	-
76	G	-
78	V	-
79	V	-
80	Y	-
82	BR	-
86	Y	-
88	W	-
81	W	-
82	L	-
83	R	-

Connector No.	M72
Connector Name	WIRE TO WIRE
Connector Type	NS12FBR-CS

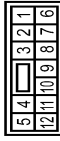

Terminal No.	Color Of Wire	Signal Name [Specification]
1	BE	-
2	R	-
4	P	-
5	L	-
6	Y	-
7	GR	-
8	SB	-
10	W	-
11	Y	-
12	Y	-

Connector No.	M73
Connector Name	BCM (BODY CONTROL MODULE)
Connector Type	FEA08FW-FH46-SA



Terminal No.	Color Of Wire	Signal Name [Specification]
58	Y	INT ROOM LAMP PWR SPLY
59	Y	BAT
58	O	AIR BAS
59	SB	PASS DOOR UNLK OUTPUT
60	V	TURN SIG LH OUTPUT
61	G	TURN SIG RH OUTPUT
62	W	STEP LAMP CONT
63	R	INT ROOM LAMP CONT
64	W	CRANK REQ
65	V	ALL DOOR LOCK OUTPUT
66	G	DR DOOR UNLK OUTPUT
67	B	GROUND
68	L	PW PWR SPLY (IGN)
69	P	PW PWR SPLY (BAT)
70	L	BAT

# LUMBAR SUPPORT SYSTEM

< WIRING DIAGRAM >

## LUMBAR SUPPORT SYSTEM

### Wiring Diagram

INFOID:000000011325284

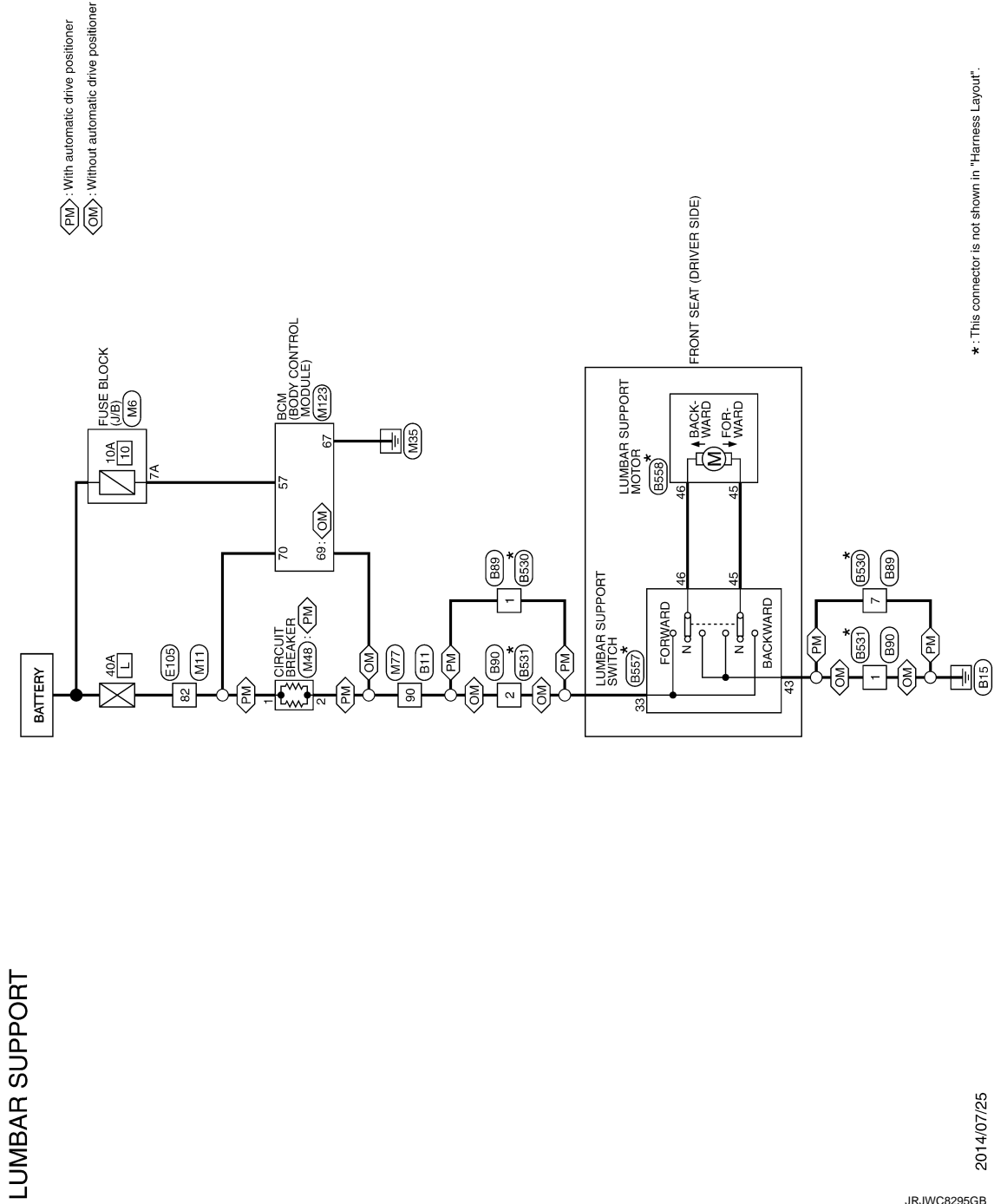

LUMBAR SUPPORT

A  
B  
C  
D  
E  
F  
G  
H  
I  
SE  
K  
L  
M  
N  
O  
P

2014/07/25  
JRJWC8295GB

# LUMBAR SUPPORT SYSTEM



< WIRING DIAGRAM >

**LUMBAR SUPPORT**

Connector No. B11

Connector Name WIRE TO WIRE

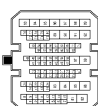
Connector Type TH80BMW-CS19





Terminal No.	Color Of Wire	Signal Name [Specification]
19	GR	-
18	GR	-
17	P	-
16	L	-
15	L	-
14	GR	-
13	W	-
12	P	-
11	Y	-
10	SHIELD	-
9	R	-
8	B	-
7	W	-
6	Y	-
5	B	-
4	W	-
3	B	-
2	Y	-
1	B	-
0	P	-
58	L	-
57	Y	-
56	L	-
55	P	-
54	GR	-
53	G	-
52	B	-
51	Y	-
50	W	-
49	B	-
48	R	-
47	SHIELD	-
46	P	-
45	L	-
44	L	-
43	GR	-
42	W	-
41	W	-
40	GR	-
39	GR	-
38	GR	-
37	GR	-
36	GR	-
35	GR	-
34	GR	-
33	GR	-
32	GR	-
31	GR	-
30	GR	-
29	GR	-
28	GR	-
27	GR	-
26	GR	-
25	GR	-
24	GR	-
23	GR	-
22	GR	-
21	GR	-
20	GR	-
19	GR	-
18	GR	-
17	GR	-
16	GR	-
15	GR	-
14	GR	-
13	GR	-
12	GR	-
11	GR	-
10	GR	-
9	GR	-
8	GR	-
7	GR	-
6	GR	-
5	GR	-
4	GR	-
3	GR	-
2	GR	-
1	GR	-

Connector No. B89

Connector Name WIRE TO WIRE

Connector Type NS16FW-CS

Terminal No.	Color Of Wire	Signal Name [Specification]
16	LG	-
15	B	-
14	L	-
13	L	-
12	P	-
11	L	-
10	L	-
9	L	-
8	L	-
7	B	-
6	LG	-
5	V	-
4	BR	-
3	GR	-
2	GR	-
1	GR	-

Connector No. B83

Connector Name WIRE TO WIRE

Connector Type NS16FW-CS



Terminal No.	Color Of Wire	Signal Name [Specification]
16	LG	-
15	B	-
14	L	-
13	L	-
12	P	-
11	L	-
10	L	-
9	L	-
8	L	-
7	B	-
6	LG	-
5	V	-
4	BR	-
3	GR	-
2	GR	-
1	GR	-

Connector No. B57

Connector Name WIRE TO WIRE

Connector Type NS16FW-CS



Terminal No.	Color Of Wire	Signal Name [Specification]
16	LG	-
15	B	-
14	L	-
13	L	-
12	P	-
11	L	-
10	L	-
9	L	-
8	L	-
7	B	-
6	LG	-
5	V	-
4	BR	-
3	GR	-
2	GR	-
1	GR	-

Connector No. B57

Connector Name WIRE TO WIRE

Connector Type NS16FW-CS



Terminal No.	Color Of Wire	Signal Name [Specification]
16	LG	-
15	B	-
14	L	-
13	L	-
12	P	-
11	L	-
10	L	-
9	L	-
8	L	-
7	B	-
6	LG	-
5	V	-
4	BR	-
3	GR	-
2	GR	-
1	GR	-

Connector No. B57

Connector Name WIRE TO WIRE

Connector Type NS16FW-CS



Terminal No.	Color Of Wire	Signal Name [Specification]
16	LG	-
15	B	-
14	L	-
13	L	-
12	P	-
11	L	-
10	L	-
9	L	-
8	L	-
7	B	-
6	LG	-
5	V	-
4	BR	-
3	GR	-
2	GR	-
1	GR	-

Connector No. B57

Connector Name WIRE TO WIRE

Connector Type NS16FW-CS



Terminal No.	Color Of Wire	Signal Name [Specification]
16	LG	-
15	B	-
14	L	-
13	L	-
12	P	-
11	L	-
10	L	-
9	L	-
8	L	-
7	B	-
6	LG	-
5	V	-
4	BR	-
3	GR	-
2	GR	-
1	GR	-

JRJWC8296GB

# LUMBAR SUPPORT SYSTEM

## < WIRING DIAGRAM >

A  
B  
C  
D  
E  
F  
G  
H  
I  
SE  
K  
L  
M  
N  
O  
P

### LUMBAR SUPPORT

Connector No.	E55B
Connector Name	LUMBAR SUPPORT MOTOR
Connector Type	1202-0556



Terminal No.	Color Of Wire	Signal Name [Specification]
45	P	--
46	BR	--

Connector No.	E10S
Connector Name	WIRE TO WIRE
Connector Type	TH70MM-CSD10-M3

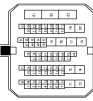

Terminal No.	Color Of Wire	Signal Name [Specification]
1	SHIELD	--
2	W	--
3	B	--
4	R	--
6	LG	--
7	R	--
8	GR	--
9	V	--
10	BR	--
11	Y	--
12	O	--
13	W	--
14	W	--
15	P	--
31	GR	--
32	V	--
37	BR	--
38	G	--

39	V	--
40	P	--
41	L	--
42	LG	--
43	O	--
45	P	--
46	SB	--
47	V	--
49	L	--
51	BR	--
52	G	--
53	B	--
54	O	--
55	Y	--
56	SHIELD	--
57	Y	--
58	G	--
59	G	--
60	W	--
61	W	--
62	W	--
63	G	--
64	W/R	--
66	W	--
67	Y	--
69	R	--
71	R	--
72	L	--
73	GR	--
74	Y	--
75	SB	--
76	Y	--
77	G	--
78	O	--
80	R	--
81	L	--
82	LG	--
83	R	--

Connector No.	IM6
Connector Name	FUSE BLOCK (J/B)
Connector Type	CS06FW-M2



Terminal No.	Color Of Wire	Signal Name [Specification]
3A	Y	--
7A	Y	--
8A	G	--
9A	GR	--
5A	V	--
6A	R	--
7A	GR	--
8A	L	--

Connector No.	M11
Connector Name	WIRE TO WIRE
Connector Type	TH70FW-25D-M3



Terminal No.	Color Of Wire	Signal Name [Specification]
1	SHIELD	--
2	W	--
3	B	--
4	R	--
5	G	--
6	C	--
8	B	--
10	R	--
11	W	--
12	L	--
12	LG	--

13	G	-- [Without automatic drive positioner]
14	Y	-- [With automatic drive positioner]
15	P	--
31	R	--
32	LG	--
37	BR	-- [With automatic drive positioner]
37	W	-- [Without automatic drive positioner]
38	R	--
39	BE	-- [Without automatic drive positioner]
39	Y	-- [With automatic drive positioner]
40	P	--
41	L	--
42	G	--
43	W	--
44	Y	--
46	V	--
47	R	--
49	G	--
51	G	--
52	W	--
53	B	--
54	LG	--
55	L	--
56	SHIELD	--
61	R	--
62	W	--
63	B	--
64	W	--
67	BR	--
68	P	--
71	R	--
72	L	--
73	LG	--
74	Y	--
75	Y	--
76	V	--
77	P	--
78	BR	--
80	Y	--
81	W	--
82	L	--
83	R	--

# LUMBAR SUPPORT SYSTEM

< WIRING DIAGRAM >

## LUMBAR SUPPORT

Connector No.	M16
Connector Name	CIRCUIT BREAKER
Connector Type	M02FW-P-LL



Terminal No.	Color Of Wire	Signal Name [Specification]
1	L	--
2	R	--

Connector No.	M17
Connector Name	WIRE TO WIRE
Connector Type	TH88FW-CS1B

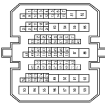

Terminal No.	Color Of Wire	Signal Name [Specification]
10	P	--
12	BE	--
13	W	--
15	R	--
29	W	--
30	P	--
31	BE	--
37	SHIELD	--
38	B	-- [Without around view monitor]
38	W	-- [With around view monitor]
39	B	-- [Without around view monitor]
39	W	-- [With around view monitor]
40	R	-- [Without around view monitor]
51	LG	--
52	B	--
53	BE	--
54	P	--
55	L	--

56	Y	PRNS DOOR UNLK OUTPUT
56	Y	TURN SIG LM OUTPUT
61	G	TURN SIG RM OUTPUT
62	W	STEP LAMP CONT
63	R	INT ROOM LAMP CONT
64	W	CRANK REQ
65	V	ALL DOOR LOCK OUTPUT
66	G	DR DOOR UNLK OUTPUT
67	B	GROUND
68	L	PW PWR SPLY (IGN)
69	P	PW PWR SPLY (BAT)
70	L	BAT

57	Y	--
58	L	--
59	BE	--
60	G	--
61	LG	--
62	SB	--
63	BE	--
64	R	--
65	G	--
66	SHIELD	--
67	B	--
68	W	--
69	SHIELD	--
70	B	--
71	G	--
72	G	--
73	G	--
74	GR	--
75	GR	--
77	W	--
78	R	--
79	W	--
80	G	--
81	L	--
82	W	--
87	V	--
88	LG	--
89	GR	--
90	X	-- [With automatic drive positioner]
90	Y	-- [Without automatic drive positioner]
91	LG	--
92	BR	--

Connector No.	M123
Connector Name	BCM (BODY CONTROL MODULE)
Connector Type	FEA09FW-FH46-SA



Terminal No.	Color Of Wire	Signal Name [Specification]
56	P	INT ROOM LAMP PWR SPLY
57	Y	BAT
58	O	AIR BAG



# HEATED SEAT SYSTEM

< WIRING DIAGRAM >

## HEATED SEAT SYSTEM

### Wiring Diagram

INFOID:000000011325285

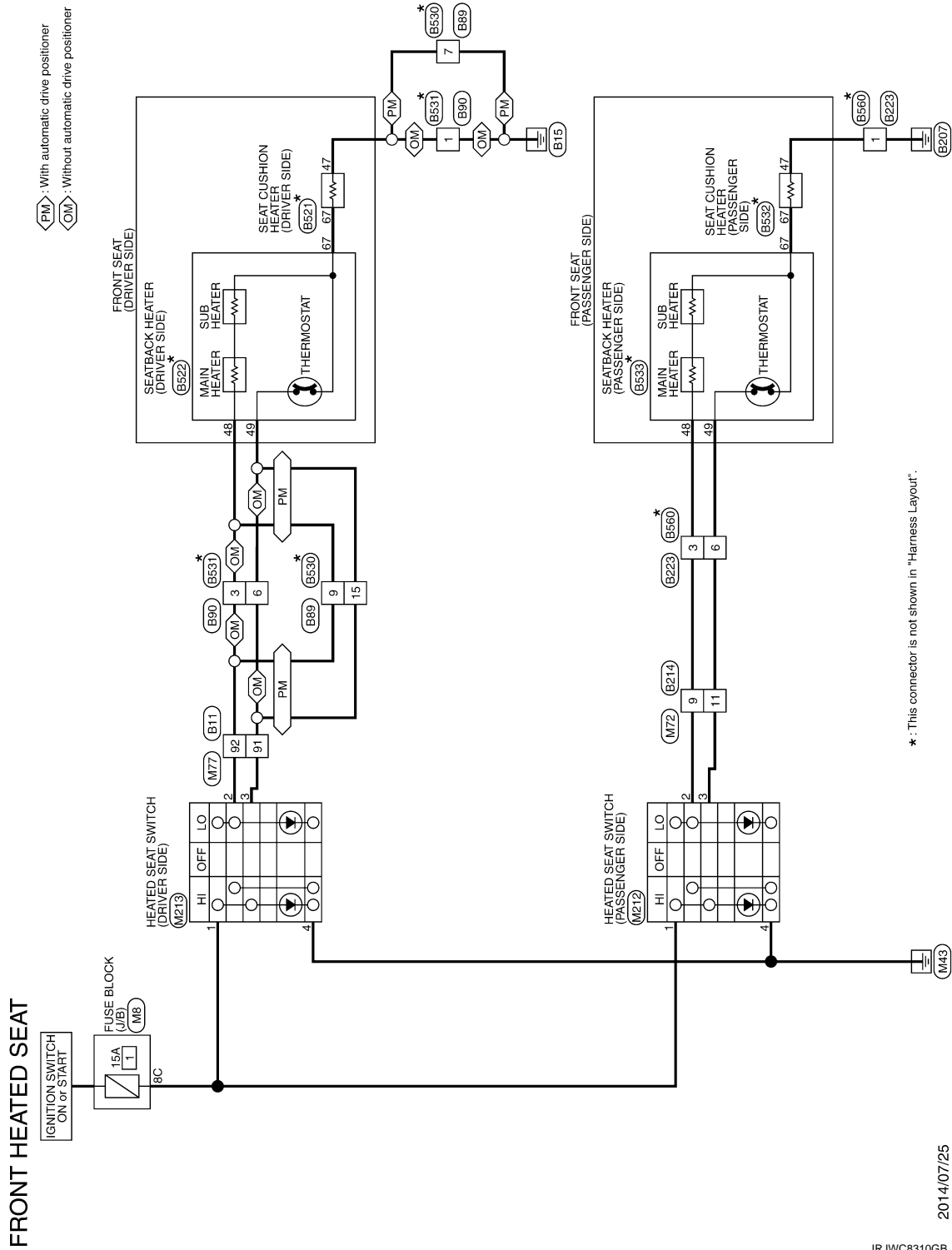

2014/07/25

JRJWC8310GB

A  
B  
C  
D  
E  
F  
G  
H  
I  
SE  
K  
L  
M  
N  
O  
P

# HEATED SEAT SYSTEM

< WIRING DIAGRAM >

## FRONT HEATED SEAT

Connector No.	B11
Connector Name	WIRE TO WIRE
Connector Type	TH80MW-CS19

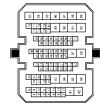

Terminal No.	Color Of Wire	Signal Name [Specification]
1	GR	--
2	GR	--
3	P	--
15	L	--
29	GR	--
30	W	--
31	P	--
37	SHIELD	--
38	R	--
39	B	--
40	W	--
51	Y	--
52	B	--
53	G	--
54	P	--
55	Y	--
57	Y	--
58	L	--
59	GR	--
60	Y	--
61	Y	--
62	BR	--
63	L	--
64	W	--
65	R	--
66	SHIELD	--
67	B	--
68	W	--
69	SHIELD	--
70	W/S	--
71	B/Y	--
72	BR	--
74	L	--
75	SB	--
77	V	--

78	LG	--
79	CS	--
80	BR	--
81	SB	--
82	V	--
87	G	--
88	V	--
89	G	--
90	Y	--
91	LG	--
92	L	--

Connector No.	B89
Connector Name	WIRE TO WIRE
Connector Type	NS16FW-CS

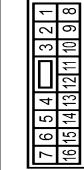

Terminal No.	Color Of Wire	Signal Name [Specification]
1	GR	--
2	GR	--
3	SR	--
4	BR	--
5	V	--
6	LG	--
7	B	--
9	L	--
11	L	--
12	P	--
13	L	--
14	LG	--
15	LG	--
16	GR	--

Connector No.	B8D
Connector Name	WIRE TO WIRE
Connector Type	NS86FW-CS



Terminal No.	Color Of Wire	Signal Name [Specification]
1	Y	--
2	B	--
3	L	--
4	LG	--
5	GR	--
6	LG	--

Connector No.	B214
Connector Name	WIRE TO WIRE
Connector Type	NS12MBR-CS

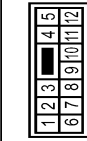

Terminal No.	Color Of Wire	Signal Name [Specification]
1	SB	--
2	L	--
4	BR	--
5	Y	--
6	V	--
7	W	--
8	LG	--
10	Y	--
11	G	--
12	SB	--

Connector No.	B223
Connector Name	WIRE TO WIRE
Connector Type	NS08FM-CS



Terminal No.	Color Of Wire	Signal Name [Specification]
1	Y	--
2	SB	--
3	LG	--
4	BR	--
5	B	--
6	G	--

Connector No.	B321
Connector Name	SEAT CUSHION HEATER (DRIVER SIDE)
Connector Type	NS02MP-CS



Terminal No.	Color Of Wire	Signal Name [Specification]
47	LG	--
67	W	--

JRJWC8311GB

# HEATED SEAT SYSTEM

< WIRING DIAGRAM >

## FRONT HEATED SEAT

Connector No.	B522
Connector Name	SEATBACK HEATER (DRIVER SIDE)
Connector Type	NSD3MW-CS



Terminal No.	Color Of Wire	Signal Name [Specification]
48	BR/W	-
67	W	-

Connector No.	B530
Connector Name	WIRE TO WIRE
Connector Type	NS18MW-CS

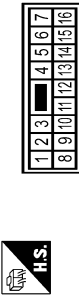

Terminal No.	Color Of Wire	Signal Name [Specification]
1	R	-
2	R/G	-
3	R/W	-
4	W/R	-
5	W/L	-
6	Y	-
7	LG	-
8	P	-
9	P	-
11	R	-
12	Y	-
13	R/G	-
14	CG	-
15	P	-
16	L/P	-

Connector No.	B531
Connector Name	WIRE TO WIRE
Connector Type	NSD6MW-CS



Terminal No.	Color Of Wire	Signal Name [Specification]
1	LG	-
2	BR/W	-
3	Y	-
4	L/P	-
5	L/P	-
6	P	-

Connector No.	B532
Connector Name	SEAT CUSHION HEATER (PASSENGER SIDE)
Connector Type	NSD2MW-CS

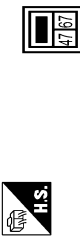

Terminal No.	Color Of Wire	Signal Name [Specification]
47	W	-
16	W	-

Connector No.	B533
Connector Name	SEATBACK HEATER (PASSENGER SIDE)
Connector Type	NSD3MW-CS



Terminal No.	Color Of Wire	Signal Name [Specification]
48	BR/W	-
67	W	-

Connector No.	B560
Connector Name	WIRE TO WIRE
Connector Type	NSD8MW-CS



Terminal No.	Color Of Wire	Signal Name [Specification]
1	LG	-
2	R	-
3	BR/W	-
4	Y	-
5	L/P	-
6	P	-

Connector No.	M8
Connector Name	FUSE BLOCK (J/B)
Connector Type	NS12PW-CS



Terminal No.	Color Of Wire	Signal Name [Specification]
10C	LG	-
11C	Y	-
12C	Y	-
6C	GR	-
7C	GR	-
8C	G	-
9C	Y	-

Connector No.	M17
Connector Name	WIRE TO WIRE
Connector Type	NS12FER-CS

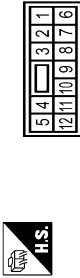

Terminal No.	Color Of Wire	Signal Name [Specification]
1	BE	-
2	R	-
4	P	-
5	L	-
6	Y	-
7	GR	-
8	SB	-
10	W	-
11	Y	-
12	Y	-

A  
B  
C  
D  
E  
F  
G  
H  
I  
SE  
K  
L  
M  
N  
O  
P

# HEATED SEAT SYSTEM

< WIRING DIAGRAM >

## FRONT HEATED SEAT

Connector No.	M17
Connector Name	WIRE TO WIRE
Connector Type	TH80FW-CS19

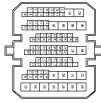

Terminal No.	Color Of Wire	Signal Name [Specification]
12	BE	--
13	W	--
15	R	--
29	W	--
30	P	--
31	BE	--
37	SHIELD	--
38	B	-- [Without around view monitor]
38	W	-- [With around view monitor]
39	B	-- [Without around view monitor]
39	W	-- [With around view monitor]
40	R	--
41	LG	--
52	BE	--
54	P	--
55	L	--
57	Y	--
58	L	--
59	BE	--
60	G	--
61	LG	--
62	SB	--
63	BE	--
64	R	--
65	G	--
68	SHIELD	--
68	B	--
68	W	--
69	SHIELD	--
70	B	--
71	W	--
72	G	--
74	GR	--
75	G	--

77	W	--
78	R	--
79	W	--
80	G	--
81	L	--
82	W	--
87	V	--
88	LG	--
89	GR	--
90	R	-- [With automatic drive positioner]
90	Y	-- [Without automatic drive positioner]
91	LG	--
92	BR	--

Connector No.	M12
Connector Name	HEATED SEAT SWITCH (PASSENGER SIDE)
Connector Type	NS306FBF-CS



Terminal No.	Color Of Wire	Signal Name [Specification]
2	SB	--
3	Y	--
4	GR	--
5	P	--
6	B	--

Connector No.	M13
Connector Name	HEATED SEAT SWITCH (DRIVER SIDE)
Connector Type	NS306FW-CS



Terminal No.	Color Of Wire	Signal Name [Specification]
2	BR	--
3	LS	--
4	B	--
5	P	--
6	GR	--

JRJWC8313GB

# SEATBACK POWER RETURN SYSTEM

< WIRING DIAGRAM >

## SEATBACK POWER RETURN SYSTEM

Wiring Diagram

INFOID:000000011325286

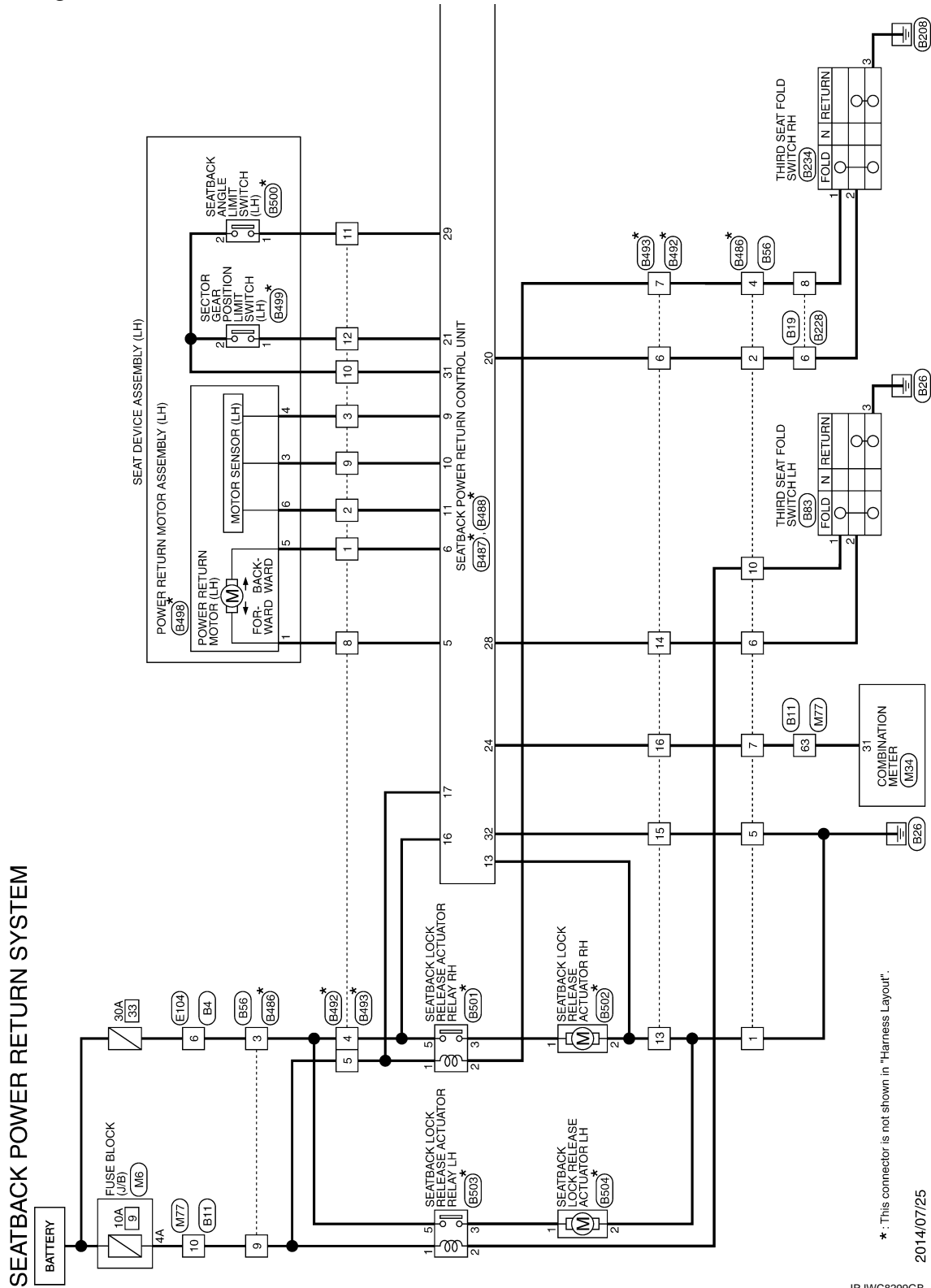

\*: This connector is not shown in "Harness Layout".

2014/07/25

JRJWC8299GB

A  
B  
C  
D  
E  
F  
G  
H  
I  
SE  
K  
L  
M  
N  
O  
P

# SEATBACK POWER RETURN SYSTEM

< WIRING DIAGRAM >

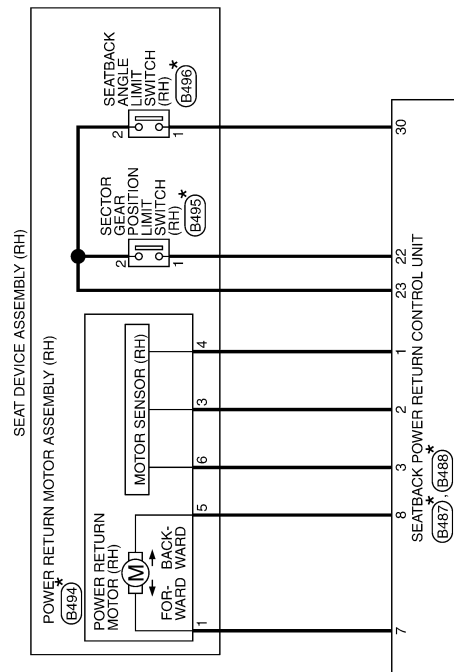

JRJWC8300GB

# SEATBACK POWER RETURN SYSTEM

< WIRING DIAGRAM >

## SEATBACK POWER RETURN SYSTEM

Connector No.	B4
Connector Name	WIRE TO WIRE
Connector Type	NH10MW-CSD0



1	2	3	4	5	6
7	8	9	10	11	12
13	14	15	16	17	18
19	20				

Connector No.	B11
Connector Name	WIRE TO WIRE
Connector Type	TH80MW-CSD9



28	LG	--
29	GR	--
30	SR	--
31	BR	--
32	V	--
37	G	--
38	V	--
39	G	--
30	Y	--
91	LG	--
92	L	--

Terminal No.	Color Of Wire	Signal Name [Specification]
1	BR	--
2	LG	--
4	P	--
5	L	--
6	R	--
7	W	--
8	B	--
9	SB	--
10	L	--
11	V	--
12	LG	--
14	LG	--
15	V	--
16	O	--
18	V	--
19	G	--
20	SB	--

Terminal No.	Color Of Wire	Signal Name [Specification]
10	GR	--
12	G	--
13	P	--
15	L	--
28	GR	--
30	W	--
31	P	--
37	SHIELD	--
38	R	--
39	B	--
40	W	--
51	Y	--
52	B	--
53	G	--
54	P	--
55	Y	--
58	L	--
59	GR	--
60	Y	--
62	BR	--
63	L	--
64	W	--
65	R	--
66	SHIELD	--
67	B	--
68	W	--
69	SHIELD	--
70	BR	--
72	BR	--
74	L	--
75	SB	--
77	V	--

Connector No.	B19
Connector Name	WIRE TO WIRE
Connector Type	NSD0FW-CS



Connector No.	B83
Connector Name	THRD SEAT FOLD SWITCH LH
Connector Type	TR08FW-TV



Terminal No.	Color Of Wire	Signal Name [Specification]
1	P	--
2	L	--
3	G	--

Terminal No.	Color Of Wire	Signal Name [Specification]
1	P	--
2	W	--
3	B	--

Connector No.	B56
Connector Name	WIRE TO WIRE
Connector Type	NS10FW-CS



Connector No.	B228
Connector Name	WIRE TO WIRE
Connector Type	NSD0MW-CS



Terminal No.	Color Of Wire	Signal Name [Specification]
1	P	--
2	L	--
6	W	--

A  
B  
C  
D  
E  
F  
G  
H  
I  
SE  
K  
L  
M  
N  
O  
P

JRJWC8301GB

# SEATBACK POWER RETURN SYSTEM

< WIRING DIAGRAM >

## SEATBACK POWER RETURN SYSTEM

8	P	-
---	---	---

Connector No.	B234
Connector Name	THIRD SEAT FOLD SWITCH RH
Connector Type	TKDBFW-1V



Terminal No.	Color Of Wire	Signal Name [Specification]
1	P	-
2	W	-
3	GR	-

Connector No.	B486
Connector Name	WIRE TO WIRE
Connector Type	NS10MWP-CS

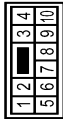

Terminal No.	Color Of Wire	Signal Name [Specification]
1	B	-
2	LG/R	-
3	R	-
4	O	-
5	B	-
6	LG/Y	-
7	G	-
10	Y	-

Connector No.	B487
Connector Name	SEATBACK POWER RETURN CONTROL UNIT
Connector Type	SUMITOMO 6088-3443



Terminal No.	Color Of Wire	Signal Name [Specification]
1	G/W	MOTOR SENS GND RH
2	Y/R	MOTOR SENS SIG RH
3	Y/R	MOTOR SENS PWR RH
5	R/B	MTR LH +
6	L/W	MTR RH +
7	R/W	MTR RH -
8	L/W	MTR RH +
9	B/Y	MOTOR SENS GND LH
10	G	MOTOR SENS SIG LH
11	Y	MOTOR SENS PWR LH
13	B	GND POWER
16	R	BAT POWER

Connector No.	B488
Connector Name	SEATBACK POWER RETURN CONTROL UNIT
Connector Type	YAZAKI 128S-4261

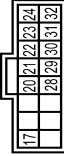

Terminal No.	Color Of Wire	Signal Name [Specification]
17	-	-
20	-	BAT SIG
21	-	RH LIMIT SW
22	-	PRMAL SW LH
23	-	RH SW GND
24	-	SPEED RPR
28	-	LH SW
29	-	RETURN SW LH

30	L/W	RETURN SW RH
31	BR	LH LIMIT SW GND
32	B	GND SIG

Connector No.	B492
Connector Name	WIRE TO WIRE
Connector Type	NS10MWP-CS

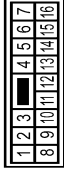

Terminal No.	Color Of Wire	Signal Name [Specification]
1	L	-
2	Y	-
3	B/Y	-
4	R	-
5	R	-
6	LG/R	-
7	O	-
8	R/B	-
9	G	-
11	BR	-
12	W	-
13	B	-
14	LG/Y	-
15	B	-
16	LG	-

Connector No.	B493
Connector Name	WIRE TO WIRE
Connector Type	NS10MWP-CS

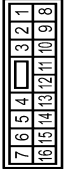

Terminal No.	Color Of Wire	Signal Name [Specification]
1	Y	-
2	Y	-
3	B/Y	-
4	R	-
5	R	-
6	LG/R	-
7	O	-
8	R/B	-
9	G	-
10	BR	-
11	L	-
12	W	-
13	B	-
14	LG/Y	-
15	B	-
16	LG	-

Connector No.	B494
Connector Name	POWER RETURN MOTOR ASSEMBLY (RH)
Connector Type	SUMITOMO 6088-0245



Terminal No.	Color Of Wire	Signal Name [Specification]
1	R/W	-
3	G/W	-
4	B/W	-
5	L/W	-

JRWJC8302GB



# SEATBACK POWER RETURN SYSTEM

< WIRING DIAGRAM >

## SEATBACK POWER RETURN SYSTEM

6	Y/R	-
---	-----	---

Connector No.	B495
Connector Name	SECTOR GEAR POSITION LIMIT SWITCH (RH)
Connector Type	YAZAKI 7283-5972



Terminal No.	Color Of Wire	Signal Name [Specification]
1	W/R	-
2	BR/W	-

Connector No.	B496
Connector Name	SEATBACK ANGLE LIMIT SWITCH (RH)
Connector Type	SUMITOMO 6089-0239



Terminal No.	Color Of Wire	Signal Name [Specification]
1	L/W	-
2	BR/W	-

Connector No.	B498
Connector Name	POWER RETURN MOTOR ASSEMBLY (LH)
Connector Type	SUMITOMO 6089-0245



Terminal No.	Color Of Wire	Signal Name [Specification]
3	P/B	-
4	B/Y	-
5	L	-
6	Y	-

Connector No.	B499
Connector Name	SECTOR GEAR POSITION LIMIT SWITCH (LH)
Connector Type	YAZAKI 7283-5972



Terminal No.	Color Of Wire	Signal Name [Specification]
1	W	-
2	BR	-

Connector No.	B500
Connector Name	SEATBACK ANGLE LIMIT SWITCH (LH)
Connector Type	SUMITOMO 6089-0239



Terminal No.	Color Of Wire	Signal Name [Specification]
1	L	-
2	BR	-

Connector No.	B501
Connector Name	SEATBACK LOCK RELEASE ACTUATOR RELAY (RH)
Connector Type	YAZAKI 7223-1559



Terminal No.	Color Of Wire	Signal Name [Specification]
1	R	-
2	O	-
3	R	-
5	R	-

Connector No.	B502
Connector Name	SEATBACK LOCK RELEASE ACTUATOR (RH)
Connector Type	YAZAKI 7123-6040



Terminal No.	Color Of Wire	Signal Name [Specification]
1	R	-
2	B	-

Connector No.	B503
Connector Name	SEATBACK LOCK RELEASE ACTUATOR RELAY (LH)
Connector Type	YAZAKI 7223-1559



Terminal No.	Color Of Wire	Signal Name [Specification]
1	R	-
2	V	-
3	R	-
5	R	-

A  
B  
C  
D  
E  
F  
G  
H  
I  
SE  
K  
L  
M  
N  
O  
P

JRJWC8303GB

# SEATBACK POWER RETURN SYSTEM

< WIRING DIAGRAM >

## SEATBACK POWER RETURN SYSTEM

Connector No.	B594
Connector Name	SEATBACK LOCK RELEASE ACTUATOR LH
Connector Type	YAZAKI 2123-6040



Terminal No.	Color Of Wire	Signal Name [Specification]
1	R	—
2	B	—

Connector No.	E104
Connector Name	WIRE TO WIRE
Connector Type	NH10FW-C510



Terminal No.	Color Of Wire	Signal Name [Specification]
1	Y	—
2	GR	—
3	BR	—
4	L	—
5	R	—
6	LG	—
7	G	—
8	R	—
9	Y	—
10	L	—
11	D	—
12	V	—
13	LG	—
14	V	—
15	V	—
16	W	—
17	W	—
18	GR	—
19	SB	—

20	V	—
----	---	---

Connector No.	M6
Connector Name	FUSE BLOCK (L/R/B)
Connector Type	CS08FW-M2

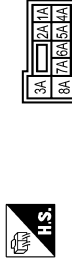

Terminal No.	Color Of Wire	Signal Name [Specification]
1A	Y	—
2A	G	—
3A	L	—
4A	GR	—
5A	V	—
6A	R	—
7A	GR	—
8A	L	—

Connector No.	ME4
Connector Name	COMBINATION METER
Connector Type	TH40FW-NH

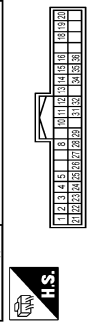

Terminal No.	Color Of Wire	Signal Name [Specification]
1	G	BATTERY POWER SUPPLY (With automatic drive positioner)
2	G	BATTERY POWER SUPPLY (Without automatic drive positioner)
3	B	IGNITION SIGNAL (With automatic drive positioner)
4	B	GROUND
5	B	ILLUMINATION CONTROL SIGNAL (With automatic drive positioner)
8	G	ILLUMINATION CONTROL SIGNAL (Without automatic drive positioner)

Terminal No.	Color Of Wire	Signal Name [Specification]
6	SB	TRIP RESET SWITCH SIGNAL (With automatic drive positioner)
8	G	METER CONTROL SWITCH GROUND
10	P	ENTER SWITCH SIGNAL
11	G	ENTER SWITCH SIGNAL
12	BR	SELECT SWITCH SIGNAL (With automatic drive positioner)
13	W	SELECT SWITCH SIGNAL (Without automatic drive positioner)
14	G	ILLUMINATION CONTROL SWITCH SIGNAL (With automatic drive positioner)
15	BR	ILLUMINATION CONTROL SWITCH SIGNAL (Without automatic drive positioner)
16	L	AIR BAG SIGNAL
18	LG	ENGINE COOLANT TEMPERATURE SIGNAL
19	R	AMBIENT SENSOR SIGNAL (With automatic drive positioner)
20	Y	AMBIENT SENSOR SIGNAL (Without automatic drive positioner)
21	L	AMBIENT SENSOR SIGNAL (Without automatic drive positioner)
22	P	CAN-L
23	B	GROUND
24	B	FUEL LEVEL SENSOR GROUND
25	BR	ALTERNATOR SIGNAL (With automatic drive positioner)
25	W	ALTERNATOR SIGNAL (Without automatic drive positioner)
26	BR	PARKING BRAKE SWITCH SIGNAL
27	BE	FRONT FUEL LEVEL SWITCH SIGNAL (With automatic drive positioner)
27	Y	FRONT FUEL LEVEL SWITCH SIGNAL (Without automatic drive positioner)
28	V	SECURITY SIGNAL
29	G	WASHER LEVEL SWITCH SIGNAL
31	SB	VEHICLE SPEED SIGNAL (8-PULSE)
32	R	OVER FUEL LEVEL SENSOR SIGNAL
34	G	OVER FUEL LEVEL SENSOR SIGNAL
35	BR	TRIP RESET SWITCH SIGNAL (With automatic drive positioner)
35	P	TRIP RESET SWITCH SIGNAL (Without automatic drive positioner)
36	BR	PASSENGER SEAT BELT WARNING SIGNAL

Connector No.	IM77
Connector Name	WIRE TO WIRE
Connector Type	TH80FW-GS19

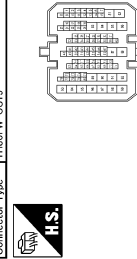

Terminal No.	Color Of Wire	Signal Name [Specification]
10	P	—
12	BE	—
13	W	—
15	R	—
29	W	—
30	P	—
31	BE	—
37	SHIELD	—
38	B	[Without around view monitor]
38	W	[With around view monitor]
39	W	[Without around view monitor]
41	LG	—
52	R	—
53	BE	—
54	P	—
55	L	—
57	Y	—
58	L	—
59	BE	—
60	G	—
61	LG	—
62	SB	—
63	BE	—
64	R	—
65	LG	—
66	SHIELD	—
67	B	—
68	W	—
69	SHIELD	—
70	B	—
71	W	—
72	G	—
74	GR	—
75	G	—
77	W	—
78	R	—
79	W	—
80	G	—
82	W	—
83	W	—
87	V	—
88	LG	—
89	GR	—
90	R	[With automatic drive positioner]
90	Y	[Without automatic drive positioner]
91	LG	—

JRJCW8304GB

# SEATBACK POWER RETURN SYSTEM

< WIRING DIAGRAM >

---

A

B

C

D

E

F

G

H

I

SE

K

L

M

N

O

P

SEATBACK POWER RETURN SYSTEM  
SEATBACK POWER RETURN SYSTEM  
SEATBACK POWER RETURN SYSTEM

JRJWC8305GB

# SEATBACK POWER FOLDING SYSTEM

< WIRING DIAGRAM >

## SEATBACK POWER FOLDING SYSTEM

Wiring Diagram

INFOID:000000011325287

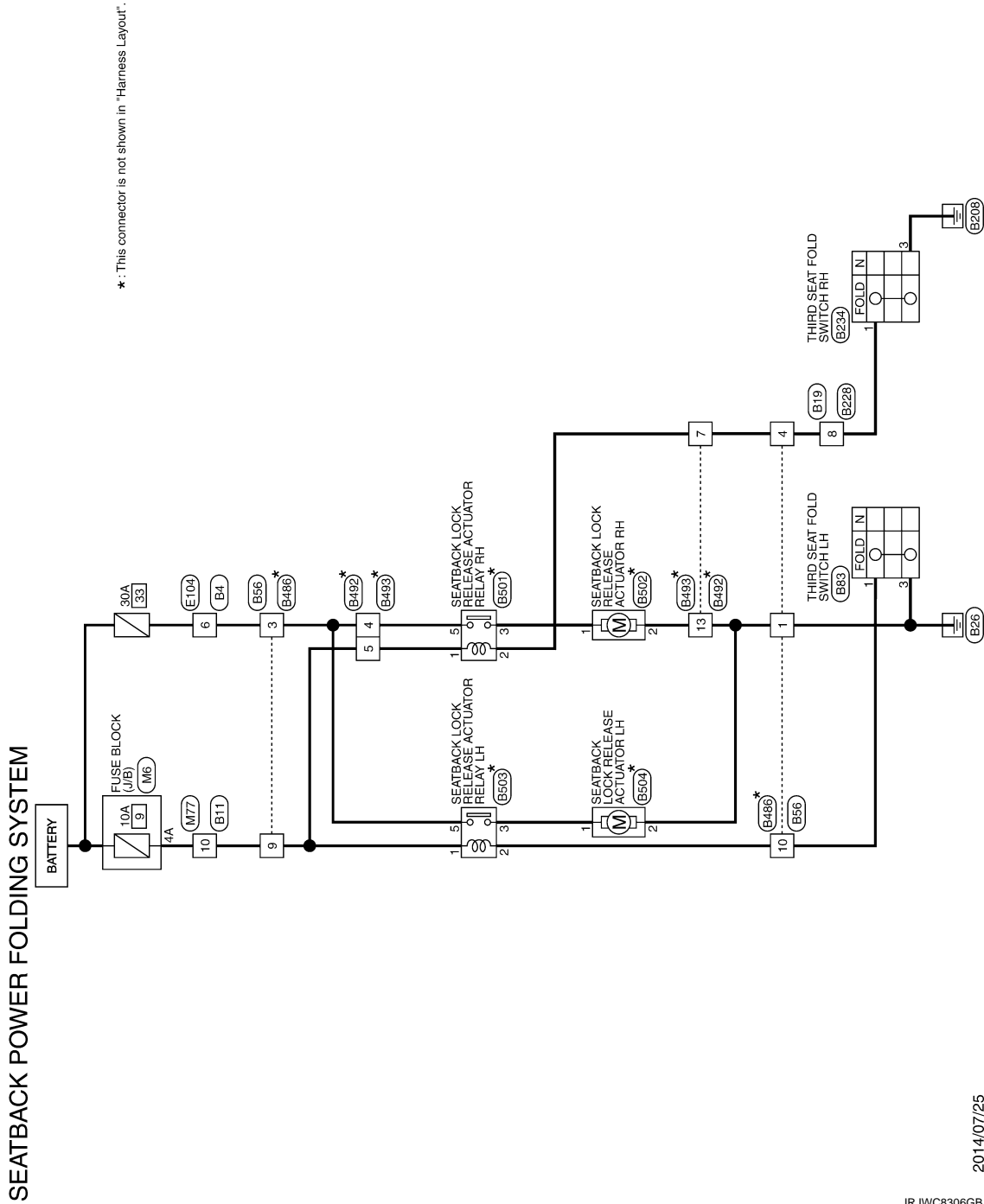



# SEATBACK POWER FOLDING SYSTEM

< WIRING DIAGRAM >

## SEATBACK POWER FOLDING SYSTEM

8	P	-
---	---	---

Connector No.	B234
Connector Name	THIRD SEAT FOLD SWITCH RH
Connector Type	TKD6FW-1V



Terminal No.	Color Of Wire	Signal Name [Specification]
1	P	-
2	W	-
3	GR	-

Connector No.	B486
Connector Name	WIRE TO WIRE
Connector Type	NS10MW-CS

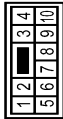

Terminal No.	Color Of Wire	Signal Name [Specification]
1	B	-
2	LG/R	-
3	R	-
4	O	-
5	B	-
6	LG/Y	-
7	G	-
8	Y	-
9	LG	-
10	Y	-

Connector No.	B492
Connector Name	WIRE TO WIRE
Connector Type	NS16MW-CS



Terminal No.	Color Of Wire	Signal Name [Specification]
1	Y	-
2	B/Y	-
3	R	-
4	R	-
5	R	-
6	LG/R	-
7	O	-
8	R/B	-
9	G	-
10	BR	-
11	L	-
12	W	-
13	B	-
14	LG/Y	-
15	G	-
16	LG	-

Connector No.	B493
Connector Name	WIRE TO WIRE
Connector Type	NS16FW-CS



Terminal No.	Color Of Wire	Signal Name [Specification]
1	L	-
2	Y	-
3	B/Y	-
4	R	-

Terminal No.	Color Of Wire	Signal Name [Specification]
5	B	-
6	LG/R	-
7	O	-
8	R/B	-
9	G	-
10	BR	-
11	L	-
12	W	-
13	B	-
14	LG/Y	-
15	B	-
16	LG	-

Connector No.	B501
Connector Name	SEATBACK LOCK RELEASE ACTUATOR RELAY RH
Connector Type	YAZAKI 7233-1559



Terminal No.	Color Of Wire	Signal Name [Specification]
1	R	-
2	V	-
3	R	-
4	O	-
5	R	-

Connector No.	B502
Connector Name	SEATBACK LOCK RELEASE ACTUATOR RH
Connector Type	YAZAKI 7123-6040



Terminal No.	Color Of Wire	Signal Name [Specification]
1	R	-
2	B	-

Connector No.	B503
Connector Name	SEATBACK LOCK RELEASE ACTUATOR RELAY LH
Connector Type	YAZAKI 7233-1559



Terminal No.	Color Of Wire	Signal Name [Specification]
1	R	-
2	V	-
3	R	-
4	O	-
5	R	-

Connector No.	B504
Connector Name	SEATBACK LOCK RELEASE ACTUATOR LH
Connector Type	YAZAKI 7123-6040



Terminal No.	Color Of Wire	Signal Name [Specification]
1	R	-
2	B	-

JRJWC8308GB

# SEATBACK POWER FOLDING SYSTEM

< WIRING DIAGRAM >

## SEATBACK POWER FOLDING SYSTEM

Connector No.	E104
Connector Name	WIRE TO WIRE
Connector Type	NH10P/M-C510

6	5	4	3	2	1
13	12	11	10	9	8
20	19	18	17	16	15
14	13	12	11	10	9
8	7	6	5	4	3
2	1				



Terminal No.	Color Of Wire	Signal Name [Specification]
1	P	
2	GR	
3	BR	
4	R	
5	R	
6	LG	
7	G	
8	R	
9	Y	
10	L	
11	P	
12	V	
14	LG	
15	V	
16	W	
17	W	
18	GR	
19	SB	
20	V	

Connector No.	M8
Connector Name	FUSE BLOCK (J/B)
Connector Type	GSD8P/M-M2

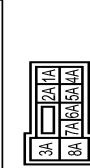

Terminal No.	Color Of Wire	Signal Name [Specification]
1A	Y	
2A	G	
3A	L	
4A	GR	
5A	V	
6A	R	
7A	GR	
8A	L	

Connector No.	M77
Connector Name	WIRE TO WIRE
Connector Type	T188P/M-C519

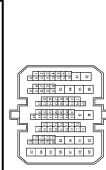

Terminal No.	Color Of Wire	Signal Name [Specification]
10	P	
12	BE	
13	W	
14	W	
15	W	
16	W	
17	W	
18	P	
30	P	
31	BE	
37	SHIELD	
38	B	- [Without around view monitor]
38	W	- [With around view monitor]
39	B	- [With around view monitor]
39	W	- [Without around view monitor]
40	R	
51	LG	
52	B	
53	BE	
54	P	
54	P	
55	Y	
58	L	
58	BE	
60	G	
61	LG	
62	SB	

63	BE	
64	C	
65	C	
66	SHIELD	
67	B	
68	W	
69	SHIELD	
70	B	
71	W	
72	G	
74	GR	
75	G	
77	W	
78	R	
79	W	
81	G	
82	W	
82	V	
87	V	
88	LG	
89	GR	
90	R	- [With automatic drive positioner]
90	Y	- [Without automatic drive positioner]
91	LG	
92	BR	

A  
B  
C  
D  
E  
F  
G  
H  
I  
SE  
K  
L  
M  
N  
O  
P

# DIAGNOSIS AND REPAIR WORK FLOW

< BASIC INSPECTION >

## BASIC INSPECTION

### DIAGNOSIS AND REPAIR WORK FLOW

Work Flow

INFOID:000000011325288

DETAILED FLOW

#### 1.OBTAIN INFORMATION ABOUT SYMPTOM

Interview the customer to obtain the malfunction information (conditions and environment when the malfunction occurred) as much as possible when the customer brings the vehicle in.

>> GO TO 2.

#### 2.REPRODUCE THE MALFUNCTION INFORMATION

Check the malfunction on the vehicle that the customer describes.  
Inspect the relation of the symptoms and the condition when the symptoms occur.

>> GO TO 3.

#### 3.IDENTIFY THE MALFUNCTIONING SYSTEM WITH "SYMPTOM DIAGNOSIS"

Use "Symptom diagnosis" from the symptom inspection result in step 2 and then identify where to start performing the diagnosis based on possible causes and symptoms.

>> GO TO 4.

#### 4.IDENTIFY THE MALFUNCTIONING PARTS WITH "DTC/CIRCUIT DIAGNOSIS"

Perform the diagnosis with "DTC/CIRCUIT DIAGNOSIS" of the applicable system.

>> GO TO 5.

#### 5.REPAIR OR REPLACE THE MALFUNCTIONING PARTS

Repair or replace the specified malfunctioning parts.

>> GO TO 6.

#### 6.FINAL CHECK

Check that malfunctions are not reproduced when obtaining the malfunction information from the customer, referring to the symptom inspection result in step 2.

Are the malfunctions corrected?

YES >> INSPECTION END

NO >> GO TO 3.



# POWER SUPPLY AND GROUND CIRCUIT

< DTC/CIRCUIT DIAGNOSIS >

## DTC/CIRCUIT DIAGNOSIS

### POWER SUPPLY AND GROUND CIRCUIT

#### Diagnosis Procedure

INFOID:000000011325289

#### 1.CHECK FUSE

Check that the following fuses are not fusing.

Signal name	Fuse No.
Battery power supply	9 (10 A)
	33 (30 A)

Is the inspection result normal?

YES >> GO TO 2.

NO >> Replace the blown fuse after repairing the affected circuit.

#### 2.CHECK POWER SUPPLY

1. Turn ignition switch OFF.
2. Disconnect seatback power return control unit connector and seatback lock release actuator relay (LH and RH) connector.
3. Check voltage between seatback power return control unit harness connector and ground.

(+)		(-)	Voltage (V)
Connector	Terminal		
B487	16	Ground	9 – 16
B488	17		

Is the measurement value normal?

YES >> GO TO 3.

NO >> Repair harness or connector.

#### 3.CHECK GROUND CIRCUIT

Check continuity between seatback power return control unit harness connector and ground.

Seatback power return control unit		Ground	Continuity
Connector	Terminal		
B487	13	Ground	Existed
B488	32		

Does continuity exist?

YES >> INSPECTION END

NO >> Repair harness or connector.

A  
B  
C  
D  
E  
F  
G  
H  
I  
SE  
K  
L  
M  
N  
O  
P

# THIRD SEAT FOLD SWITCH

< DTC/CIRCUIT DIAGNOSIS >

## THIRD SEAT FOLD SWITCH

LH

LH : Component Function Check

INFOID:000000011325290

### 1.CHECK FUNCTION

Check that the third seat fold switch (LH) operation.

Is the inspection result normal?

YES >> INSUPECTION END

NO >> Refer to [SE-50. "LH : Diagnosis Procedure"](#).

LH : Diagnosis Procedure

INFOID:000000011325291

### 1.CHECK THIRD SEAT FOLD SWITCH (LH) GROUND CIRCUIT

1. Turn ignition switch OFF.
2. Disconnect third seat fold switch (LH) connector.
3. Check continuity between third seat fold switch (LH) harness connector and ground.

Third seat fold switch (LH)		Ground	Continuity
Connector	Terminal		
B83	3		Existed

Is the inspection result normal?

YES >> GO TO 2.

NO >> Repair or replace harness.

### 2.CHECK THIRD SEAT FOLD SWITCH (LH) RETURN SIGNAL

Check voltage between third seat fold switch (LH) harness connector and ground.

Third seat fold switch (LH)		(-)	Voltage (V)
Connector	Terminal		
B83	2	Ground	4.7 – 5.3

Is the inspection result normal?

YES >> GO TO 4.

NO >> GO TO 3.

### 3.CHECK THIRD SEAT FOLD SWITCH (LH) CIRCUIT 1

1. Disconnect seatback power return control unit connector.
2. Check continuity between seatback power return control unit harness connector and third seat fold switch (LH) harness connector.

Seatback power return control unit		Third seat fold switch (LH)		Continuity
Connector	Terminal	Connector	Terminal	
B488	28	B83	2	Existed

3. Check continuity between seatback power return control unit harness connector and ground.

Seatback power return control unit		Ground	Continuity
Connector	Terminal		
B488	28		Not existed

Is the inspection result normal?

YES >> Replace rear power return control unit. Refer to [SE-140. "Removal and Installation"](#).

NO >> Repair or replace harness.

# THIRD SEAT FOLD SWITCH

< DTC/CIRCUIT DIAGNOSIS >

## 4. CHECK THIRD SEAT FOLD SWITCH (LH) FOLD SIGNAL

Check voltage between third seat fold switch (LH) harness connector and ground.

(+)		(-)	Voltage (V)
Third seat fold switch (LH)			
Connector	Terminal		
B83	1	Ground	9 – 16

Is the inspection result normal?

- YES >> GO TO 9.  
NO >> GO TO 5.

## 5. CHECK THIRD SEAT FOLD SWITCH (LH) CIRCUIT 2

1. Disconnect seatback lock release actuator relay (LH) connector.
2. Check continuity between seatback lock release actuator relay (LH) harness connector and third seat fold switch (LH) harness connector.

Seatback lock release actuator relay (LH)		Third seat fold switch (LH)		Continuity
Connector	Terminal	Connector	Terminal	
B503	2	B83	1	Existed

3. Check continuity between third seat fold switch (LH) harness connector and ground.

Third seat fold switch (LH)		Ground	Continuity
Connector	Terminal		
B83	1		Not existed

Is the inspection result normal?

- YES >> GO TO 6.  
NO >> Repair or replace harness.

## 6. CHECK THIRD SEAT FOLD SWITCH (LH) CIRCUIT 3

Check voltage between seatback lock release actuator relay (LH) harness connector and ground.

(+)		(-)	Voltage (V)
Seatback lock release actuator relay (LH)			
Connector	Terminal		
B503	1	Ground	9 – 16

Is the inspection result normal?

- YES >> GO TO 8.  
NO >> GO TO 7.

## 7. CHECK FUSE

Check 10 A fuse [#9, located fuse block (J/B)].

Is the inspection result normal?

- YES >> GO TO 10.  
NO >> Replace the blown fuse after repairing affected circuit.

## 8. CHECK SEATBACK LOCK RELEASE ACTUATOR RELAY (LH)

Check seatback lock release actuator relay (LH).

Refer to [SE-54. "Component Inspection \(Seatback Lock Release Actuator Relay\)".](#)

Is the inspection result normal?

- YES >> GO TO 10.  
NO >> Replace seatback lock release actuator relay (LH).

## 9. CHECK THIRD SEAT FOLD SWITCH (LH)

A  
B  
C  
D  
E  
F  
G  
H  
I  
K  
L  
M  
N  
O  
P

SE

# THIRD SEAT FOLD SWITCH

## < DTC/CIRCUIT DIAGNOSIS >

Check third seat fold switch (LH).

Refer to [SE-54, "Component Inspection \(Third Seat Fold Switch\)"](#).

Is the inspection result normal?

YES >> GO TO 10.

NO >> Replace third seat fold switch (LH). Refer to [SE-137, "Removal and Installation"](#).

## 10.CHECK INTERMITTENT INCIDENT

Refer to [GI-42, "Intermittent Incident"](#).

>> INSPECTION END

RH

## RH : Component Function Check

INFOID:000000011325292

### 1.CHECK FUNCTION

Check that the third seat fold switch (RH) operation.

Is the inspection result normal?

YES >> INSPECTION END

NO >> Refer to [SE-52, "RH : Diagnosis Procedure"](#).

## RH : Diagnosis Procedure

INFOID:000000011325293

### 1.CHECK THIRD SEAT FOLD SWITCH (RH) GROUND CIRCUIT

1. Turn ignition switch OFF.
2. Disconnect third seat fold switch (RH) connector.
3. Check continuity between third seat fold switch (RH) harness connector and ground.

Third seat fold switch (RH)		Ground	Continuity
Connector	Terminal		
B234	3		Existed

Is the inspection result normal?

YES >> GO TO 2.

NO >> Repair or replace harness.

### 2.CHECK THIRD SEAT FOLD SWITCH (RH) RETURN SIGNAL

Check voltage between third seat fold switch (RH) harness connector and ground.

Third seat fold switch (RH)		(-)	Voltage (V)
Connector	Terminal		
B234	2	Ground	4.7 – 5.3

Is the inspection result normal?

YES >> GO TO 4.

NO >> GO TO 3.

### 3.CHECK THIRD SEAT FOLD SWITCH (RH) CIRCUIT 1

1. Disconnect seatback power return control unit connector.
2. Check continuity between seatback power return control unit harness connector and third seat fold switch (RH) harness connector.

Seatback power return control unit		Third seat fold switch (RH)		Continuity
Connector	Terminal	Connector	Terminal	
B488	20	B234	2	Existed

3. Check continuity between seatback power return control unit harness connector and ground.

# THIRD SEAT FOLD SWITCH

## < DTC/CIRCUIT DIAGNOSIS >

Seatback power return control unit		Ground	Continuity
Connector	Terminal		
B488	20		Not existed

Is the inspection result normal?

- YES >> Replace rear power return control unit. Refer to [SE-140, "Removal and Installation"](#).  
 NO >> Repair or replace harness.

### 4.CHECK THIRD SEAT FOLD SWITCH (RH) FOLD SIGNAL

Check voltage between third seat fold switch (RH) harness connector and ground.

(+)		(-)	Voltage (V)
Third seat fold switch (RH)			
Connector	Terminal		
B234	1	Ground	9 – 16

Is the inspection result normal?

- YES >> GO TO 9.  
 NO >> GO TO 5.

### 5.CHECK THIRD SEAT FOLD SWITCH (RH) CIRCUIT 2

1. Disconnect seatback lock release actuator relay (RH) connector.
2. Check continuity between seatback lock release actuator relay (RH) harness connector and third seat fold switch (RH) harness connector.

Seatback lock release actuator relay (RH)		Third seat fold switch (RH)		Continuity
Connector	Terminal	Connector	Terminal	
B501	2	B234	1	Existed

3. Check continuity between third seat fold switch (RH) harness connector and ground.

Third seat fold switch (RH)		Ground	Continuity
Connector	Terminal		
B234	1		Not existed

Is the inspection result normal?

- YES >> GO TO 6.  
 NO >> Repair or replace harness.

### 6.CHECK THIRD SEAT FOLD SWITCH (RH) CIRCUIT 3

Check voltage between seatback lock release actuator relay (RH) harness connector and ground.

(+)		(-)	Voltage (V)
Seatback lock release actuator relay (RH)			
Connector	Terminal		
B501	1	Ground	9 – 16

Is the inspection result normal?

- YES >> GO TO 8.  
 NO >> GO TO 7.

### 7.CHECK FUSE

Check 10 A fuse [#9, located fuse block (J/B)].

Is the inspection result normal?

- YES >> GO TO 10.  
 NO >> Replace the blown fuse after repairing affected circuit.

## THIRD SEAT FOLD SWITCH

< DTC/CIRCUIT DIAGNOSIS >

### 8. CHECK SEATBACK LOCK RELEASE ACTUATOR RELAY (RH)

Check seatback lock release actuator relay (RH).

Refer to [SE-54, "Component Inspection \(Seatback Lock Release Actuator Relay\)"](#).

Is the inspection result normal?

YES >> GO TO 10.

NO >> Replace seatback lock release actuator relay (RH).

### 9. CHECK THIRD SEAT FOLD SWITCH (RH)

Check third seat fold switch (RH).

Refer to [SE-54, "Component Inspection \(Third Seat Fold Switch\)"](#).

Is the inspection result normal?

YES >> GO TO 10.

NO >> Replace third seat fold switch (RH). Refer to [SE-137, "Removal and Installation"](#).

### 10. CHECK INTERMITTENT INCIDENT

Refer to [GI-42, "Intermittent Incident"](#).

>> INSPECTION END

## Component Inspection (Third Seat Fold Switch)

INFOID:000000011325294

### 1. CHECK THIRD SEAT FOLD SWITCH

1. Turn ignition switch OFF.
2. Remove third seat fold switch. Refer to [SE-137, "Removal and Installation"](#).
3. Check third seat fold switch terminals under the following conditions.

Terminal		Condition		Continuity	
1	3	Third seat fold switch	FOLD	While being pressed	Existed
				Other than the above	Not existed
2			RETURN	While being pressed	Existed
				Other than the above	Not existed

Is the inspection result normal?

YES >> INSPECTION END

NO >> Replace third seat fold switch. Refer to [SE-137, "Removal and Installation"](#).

## Component Inspection (Seatback Lock Release Actuator Relay)

INFOID:000000011325295

### 1. CHECK SEATBACK LOCK ACCTUATOR RELAY

1. Turn ignition switch OFF.
2. Remove seatback lock actuator relay.
3. Check seatback lock actuator relay terminals under the following conditions.

Terminal	Condition	Continuity
3	12 V direct current supply between terminals 1 and 2.	Existed
5	Not current supply	Not existed

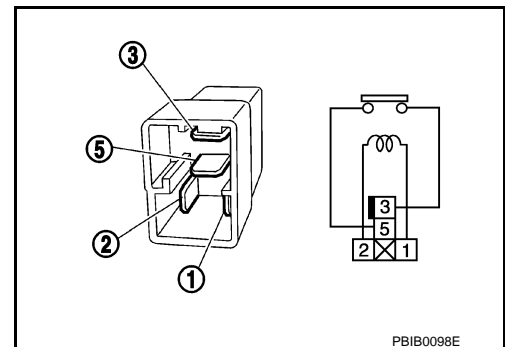

Is the inspection result normal?

YES >> INSPECTION END

NO >> Replace seatback lock actuator relay.

# VEHICLE SPEED SIGNAL CIRCUIT

< DTC/CIRCUIT DIAGNOSIS >

## VEHICLE SPEED SIGNAL CIRCUIT

### Diagnosis Procedure

INFOID:000000011325296

#### 1. CHECK VEHICLE SPEED SIGNAL

1. Start engine.
2. Drive the vehicle at more than 40 km/h (25 MPH).

**CAUTION:**

**Always drive vehicle at a safe speed.**

**NOTE:**

This procedure may be conducted with the drive wheels lifted in the shop or by driving the vehicle. If a road test is expected to be easier, it is unnecessary to lift the vehicle.

3. Check signal between seatback power return control unit harness connector and ground with an oscilloscope.

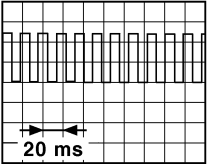
(+)		(-)	Signal (Reference value)
Seatback power return control unit			
Connector	Terminal		
B488	24	Ground	 <p style="text-align: right; font-size: small;">JSNIA0012GB</p>

Is the inspection result normal?

YES >> GO TO 3.

NO >> GO TO 2.

#### 2. CHECK VEHICLE SPEED SIGNAL CIRCUIT

1. Turn ignition switch OFF.
2. Disconnect seatback power return control unit connector and combination meter connector.
3. Check continuity between seatback power return control unit harness connector and combination meter harness connector.

Seatback power return control unit		Combination meter		Continuity
Connector	Terminal	Connector	Terminal	
B488	24	M34	31	Existed

4. Check continuity between seatback power return control unit harness connector and ground.

Seatback power return control unit		Ground	Continuity
Connector	Terminal		
B488	24		Not existed

Is the inspection result normal?

YES >> Replace combination meter. Refer to [MWI-90, "Removal and Installation"](#).

NO >> Repair or replace harness.

#### 3. CHECK INTERMITTENT INCIDENT

Refer to [GI-42, "Intermittent Incident"](#).

>> INSPECTION END

# SEATBACK ANGLE LIMIT SWITCH

< DTC/CIRCUIT DIAGNOSIS >

## SEATBACK ANGLE LIMIT SWITCH

LH

LH : Diagnosis Procedure

INFOID:000000011325297

### 1. CHECK SEATBACK ANGLE LIMIT SWITCH (LH) INPUT SIGNAL

1. Turn ignition switch OFF.
2. Disconnect seatback angle limit switch (LH) connector.
3. Check voltage between seatback angle limit switch (LH) harness connector and ground.

(+)		(-)	Voltage (V)
Seatback angle limit switch (LH)			
Connector	Terminal	Ground	9 – 16
B500	1		

#### NOTE:

It is not low power consumption mode.

Is the inspection result normal?

YES >> GO TO 3.

NO >> GO TO 2.

### 2. CHECK SEATBACK ANGLE LIMIT SWITCH (LH) CIRCUIT

1. Disconnect seatback power return control unit connector.
2. Check continuity between seatback power return control unit harness connector and seatback angle limit switch (LH) harness connector.

Seatback power return control unit		Seatback angle limit switch (LH)		Continuity
Connector	Terminal	Connector	Terminal	
B488	29	B500	1	Existed

3. Check continuity between seatback power return control unit harness connector and ground.

Seatback power return control unit		Ground	Continuity
Connector	Terminal		
B488	29		Not existed

Is the inspection result normal?

YES >> Replace seatback power return control unit. Refer to [SE-140, "Removal and Installation"](#).

NO >> Repair or replace harness.

### 3. CHECK SEATBACK ANGLE LIMIT SWITCH (LH) GROUND CIRCUIT

1. Disconnect seatback power return control unit connector and sector gear position limit switch connector.
2. Check continuity between seatback power return control unit harness connector and seatback angle limit switch (LH) harness connector.

Seatback power return control unit		Seatback angle limit switch (LH)		Continuity
Connector	Terminal	Connector	Terminal	
B488	31	B500	2	Existed

3. Check continuity between seatback power return control unit harness connector and ground.

Seatback power return control unit		Ground	Continuity
Connector	Terminal		
B488	31		Not existed

Is the inspection result normal?

YES >> GO TO 4.



# SEATBACK ANGLE LIMIT SWITCH

## < DTC/CIRCUIT DIAGNOSIS >

NO >> Repair or replace harness.

### 4.CHECK SEATBACK ANGLE LIMIT SWITCH (LH)

Check seatback angle limit switch (LH).  
Refer to [SE-58. "Component Inspection"](#).

Is the inspection result normal?

YES >> GO TO 5.

NO >> Replace seatback angle limit switch (LH) [reclining device assembly (LH)]. Refer to [SE-123. "Exploded View"](#).

### 5.CHECK INTERMITTENT INCIDENT

Refer to [GI-42. "Intermittent Incident"](#).

>> INSPECTION END

## RH

### RH : Diagnosis Procedure

INFOID:0000000011325298

### 1.CHECK SEATBACK ANGLE LIMIT SWITCH (RH) INPUT SIGNAL

1. Turn ignition switch OFF.
2. Disconnect seatback angle limit switch (RH) connector.
3. Check voltage between seatback angle limit switch (RH) harness connector and ground.

(+)		(-)	Voltage (V)
Seatback angle limit switch (RH)			
Connector	Terminal		
B496	1	Ground	9 – 16

#### NOTE:

It is not low power consumption mode.

Is the inspection result normal?

YES >> GO TO 3.

NO >> GO TO 2.

### 2.CHECK SEATBACK ANGLE LIMIT SWITCH (RH) CIRCUIT

1. Disconnect seatback power return control unit connector.
2. Check continuity between seatback power return control unit harness connector and seatback angle limit switch (RH) harness connector.

Seatback power return control unit		Seatback angle limit switch (RH)		Continuity
Connector	Terminal	Connector	Terminal	
B488	30	B496	1	Existed

3. Check continuity between seatback power return control unit harness connector and ground.

Seatback power return control unit		Ground	Continuity
Connector	Terminal		
B488	30		Not existed

Is the inspection result normal?

YES >> Replace seatback power return control unit. Refer to [SE-140. "Removal and Installation"](#).

NO >> Repair or replace harness.

### 3.CHECK SEATBACK ANGLE LIMIT SWITCH (RH) GROUND CIRCUIT

1. Disconnect seatback power return control unit connector and sector gear position limit switch connector.
2. Check continuity between seatback power return control unit harness connector and seatback angle limit switch (RH) harness connector.

# SEATBACK ANGLE LIMIT SWITCH

## < DTC/CIRCUIT DIAGNOSIS >

Seatback power return control unit		Seatback angle limit switch (RH)		Continuity
Connector	Terminal	Connector	Terminal	
B488	23	B496	2	Existed

3. Check continuity between seatback power return control unit harness connector and ground.

Seatback power return control unit		Ground	Continuity
Connector	Terminal		
B488	23		Not existed

Is the inspection result normal?

- YES >> GO TO 4.  
 NO >> Repair or replace harness.

### 4.CHECK SEATBACK ANGLE LIMIT SWITCH (RH)

Check seatback angle limit switch (RH).  
 Refer to [SE-58, "Component Inspection"](#).

Is the inspection result normal?

- YES >> GO TO 5.  
 NO >> Replace seatback angle limit switch (RH) [reclining device assembly (RH)]. Refer to [SE-123, "Exploded View"](#).

### 5.CHECK INTERMITTENT INCIDENT

Refer to [GI-42, "Intermittent Incident"](#).

>> INSPECTION END

## Component Inspection

INFOID:000000011325299

### COMPONENT INSPECTION

#### 1.CHECK SEATBACK ANGLE LIMIT SWITCH

- Turn ignition switch OFF.
- Disconnect seatback angle limit switch connector.
- Check seatback angle limit switch terminals under the following conditions.

Terminal		Condition	Continuity
1	2		
		Seatback angle limit switch	While being pressed Existed
			Other than the above Not existed

Is the inspection result normal?

- YES >> INSPECTION END  
 NO >> Replace seatback angle limit switch (reclining device assembly). Refer to [SE-123, "Exploded View"](#).

# SEATBACK LOCK RELEASE ACTUATOR

< DTC/CIRCUIT DIAGNOSIS >

## SEATBACK LOCK RELEASE ACTUATOR

LH

LH : Diagnosis Procedure

INFOID:0000000011325300

### 1. CHECK SEATBACK LOCK RELEASE ACTUATOR (LH) GROUND CIRCUIT

Check continuity between seatback lock release actuator (LH) harness connector and ground.

Seatback lock release actuator (LH)		Ground	Continuity
Connector	Terminal		
B504	2		Existed

Is the inspection result normal?

YES >> GO TO 2.

NO >> Repair or replace harness.

### 2. CHECK FUSE

Check 30 A fuse (#33).

Is the inspection result normal?

YES >> GO TO 3.

NO >> Replace the blown fuse after repairing affected circuit.

### 3. CHECK SEATBACK LOCK RELEASE ACTUATOR (LH) POWER SUPPLY 1

1. Turn ignition switch OFF.
2. Disconnect seatback lock release actuator (LH) connector.
3. Check continuity between seatback lock release actuator (LH) harness connector and ground.

(+)		(-)	Condition	Voltage (V)
Connector	Terminal			
B504	1	Ground	Third seat fold switch (LH)	While being pressed 9 – 16
				Other than the above 0

Is the inspection result normal?

YES >> Replace seatback lock release actuator (LH). Refer to [SE-123, "Exploded View"](#).

NO >> GO TO 4.

### 4. CHECK SEATBACK LOCK RELEASE ACTUATOR (LH) POWER SUPPLY 2

1. Disconnect seatback lock release actuator relay (LH) connector.
2. Check continuity between seatback lock release actuator relay (LH) harness connector and ground.

(+)		(-)	Voltage (V)
Connector	Terminal		
B503	5	Ground	9 – 16

Is the inspection result normal?

YES >> GO TO 5.

NO >> Repair or replace harness.

### 5. CHECK SEATBACK LOCK RELEASE ACTUATOR (LH) POWER SUPPLY CIRCUIT

1. Check continuity between seatback lock release actuator relay (LH) harness connector and seatback lock release actuator (LH) harness connector.

# SEATBACK LOCK RELEASE ACTUATOR

## < DTC/CIRCUIT DIAGNOSIS >

Seatback lock release actuator relay (LH)		Seatback lock release actuator (LH)		Continuity
Connector	Terminal	Connector	Terminal	
B503	3	B504	1	Existed

2. Check continuity between seatback lock release actuator relay (LH) harness connector and ground.

(+)		(-)	Continuity
Seatback lock release actuator relay (LH)			
Connector	Terminal		
B503	3	Ground	Not existed

Is the inspection result normal?

YES >> GO TO 6.

NO >> Repair or replace harness.

### 6.CHECK SEATBACK LOCK RELEASE ACTUATOR RELAY (LH)

Check seatback lock release actuator relay (LH).

Refer to [SE-62. "Component Inspection \(Seatback Lock Release Actuator Relay\)"](#).

Is the inspection result normal?

YES >> GO TO 7.

NO >> Replace seatback lock release actuator relay (LH).

### 7.CHECK INTERMITTENT INCIDENT

Refer to [GI-42. "Intermittent Incident"](#).

>> INSPECTION END

RH

RH : Diagnosis Procedure

INFOID:000000011325301

### 1.CHECK SEATBACK LOCK RELEASE ACTUATOR (RH) GROUND CIRCUIT

Check continuity between seatback lock release actuator (RH) harness connector and ground.

Seatback lock release actuator (RH)		Ground	Continuity
Connector	Terminal		
B502	2		Existed

Is the inspection result normal?

YES >> GO TO 2.

NO >> Repair or replace harness.

### 2.CHECK FUSE

Check 30 A fuse (#33).

Is the inspection result normal?

YES >> GO TO 3.

NO >> Replace the blown fuse after repairing affected circuit.

### 3.CHECK SEATBACK LOCK RELEASE ACTUATOR (RH) POWER SUPPLY 1

1. Turn ignition switch OFF.
2. Disconnect seatback lock release actuator (RH) connector.
3. Check continuity between seatback lock release actuator (RH) harness connector and ground.

# SEATBACK LOCK RELEASE ACTUATOR

## < DTC/CIRCUIT DIAGNOSIS >

(+)		(-)	Condition	Voltage (V)
Seatback lock release actuator (RH)				
Connector	Terminal			
B502	1	Ground	Third seat fold switch (RH)	While being pressed 9 – 16
				Other than the above 0

Is the inspection result normal?

YES >> Replace seatback lock release actuator (RH). Refer to [SE-123. "Exploded View"](#).

NO >> GO TO 4.

### 4. CHECK SEATBACK LOCK RELEASE ACTUATOR (RH) POWER SUPPLY 2

1. Disconnect seatback lock release actuator relay (RH) connector.
2. Check continuity between seatback lock release actuator relay (RH) harness connector and ground.

(+)		(-)	Voltage (V)
Seatback lock release actuator relay (RH)			
Connector	Terminal		
B501	5	Ground	9 – 16

Is the inspection result normal?

YES >> GO TO 5.

NO >> Repair or replace harness.

### 5. CHECK SEATBACK LOCK RELEASE ACTUATOR (RH) POWER SUPPLY CIRCUIT

1. Check continuity between seatback lock release actuator relay (RH) harness connector and seatback lock release actuator (RH) harness connector.

Seatback lock release actuator relay (RH)		Seatback lock release actuator (RH)		Continuity
Connector	Terminal	Connector	Terminal	
B501	3	B502	1	Existed

2. Check continuity between seatback lock release actuator relay (RH) harness connector and ground.

(+)		(-)	Continuity
Seatback lock release actuator relay (RH)			
Connector	Terminal		
B501	3	Ground	Not existed

Is the inspection result normal?

YES >> GO TO 6.

NO >> Repair or replace harness.

### 6. CHECK SEATBACK LOCK RELEASE ACTUATOR RELAY (RH)

Check seatback lock release actuator relay (RH).

Refer to [SE-62. "Component Inspection \(Seatback Lock Release Actuator Relay\)"](#).

Is the inspection result normal?

YES >> GO TO 7.

NO >> Replace seatback lock release actuator relay (RH).

### 7. CHECK INTERMITTENT INCIDENT

Refer to [GI-42. "Intermittent Incident"](#).

>> INSPECTION END

# SEATBACK LOCK RELEASE ACTUATOR

< DTC/CIRCUIT DIAGNOSIS >

## Component Inspection (Seatback Lock Release Actuator Relay)

INFOID:000000011325302

### 1. CHECK SEATBACK LOCK ACCTUATOR RELAY

1. Turn ignition switch OFF.
2. Remove seatback lock actuator relay.
3. Check seatback lock actuator relay terminals under the following conditions.

Terminal		Condition	Continuity
3	5	12 V direct current supply between terminals 1 and 2.	Existed
		Not current supply	Not existed

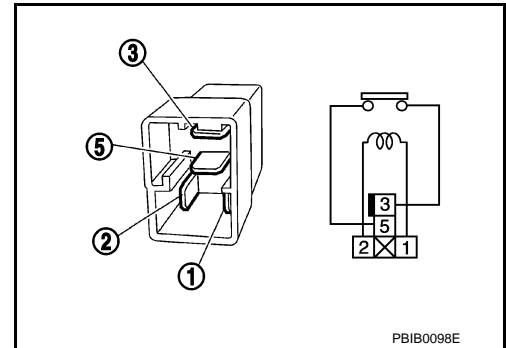

Is the inspection result normal?

- YES >> INSPECTION END  
NO >> Replace seatback lock actuator relay.

# SECTOR GEAR POSITION LIMIT SWITCH

< DTC/CIRCUIT DIAGNOSIS >

## SECTOR GEAR POSITION LIMIT SWITCH

LH

LH : Diagnosis Procedure

INFOID:000000011325303

### 1. CHECK SECTOR GEAR POSITION LIMIT SWITCH INPUT SIGNAL

1. Turn ignition switch OFF.
2. Disconnect sector gear position limit switch (LH) connector.
3. Check voltage between sector gear position limit switch (LH) connector and ground.

(+)		(-)	Voltage (V)
Sector gear position limit switch (LH)			
Connector	Terminal		
B499	1	Ground	9 – 16

**NOTE:**

It is not low electric power consumption mode.

Is the inspection result normal?

YES >> GO TO 3.

NO >> GO TO 2.

### 2. CHECK SECTOR GEAR POSITION LIMIT SWITCH (LH) SIGNAL CIRCUIT

1. Disconnect seatback power return control unit connector.
2. Check continuity between seatback power return control unit harness connector and sector gear position limit switch (LH) harness connector.

Seatback power return control unit		Sector gear position limit switch (LH)		Continuity
Connector	Terminal	Connector	Terminal	
B488	21	B499	1	Existed

3. Check continuity between seatback power return control unit harness connector and ground.

Seatback power return control unit		Ground	Continuity
Connector	Terminal		
B488	21		Not existed

Is the inspection result normal?

YES >> Replace seatback power return control unit. Refer to [SE-140, "Removal and Installation"](#).

NO >> Repair or replace harness.

### 3. CHECK SECTOR GEAR POSITION LIMIT SWITCH (LH) GROUND CIRCUIT

1. Disconnect seatback power return control unit connector and seatback angle limit switch (LH) connector.
2. Check continuity between seatback power return control unit harness connector and sector gear position limit switch (LH) harness connector.

Seatback power return control unit		Sector gear position limit switch (LH)		Continuity
Connector	Terminal	Connector	Terminal	
B488	31	B499	2	Existed

3. Check continuity between seatback power return control unit harness connector and ground.

Seatback power return control unit		Ground	Continuity
Connector	Terminal		
B488	31		Not existed

Is the inspection result normal?

YES >> GO TO 4.

# SECTOR GEAR POSITION LIMIT SWITCH

## < DTC/CIRCUIT DIAGNOSIS >

NO >> Repair or replace harness.

### 4. CHECK SECTOR GEAR POSITION LIMIT SWITCH (LH)

Check sector gear position limit switch (LH).

Refer to [SE-65, "Component Inspection"](#).

Is the inspection result normal?

YES >> GO TO 5.

NO >> Replace sector gear position limit switch (LH) [reclining device assembly (LH)]. Refer to [SE-123, "Exploded View"](#).

### 5. CHECK INTERMITTENT INCIDENT

Refer to [GI-42, "Intermittent Incident"](#).

>> INSPECTION END

RH

## RH : Diagnosis Procedure

INFOID:000000011325304

### 1. CHECK SECTOR GEAR POSITION LIMIT SWITCH INPUT SIGNAL

1. Turn ignition switch OFF.
2. Disconnect sector gear position limit switch (RH) connector.
3. Check voltage between sector gear position limit switch (RH) connector and ground.

(+)		(-)	Voltage (V)
Sector gear position limit switch (RH)			
Connector	Terminal		
B495	1	Ground	9 – 16

**NOTE:**

It is not low electric power consumption mode.

Is the inspection result normal?

YES >> GO TO 3.

NO >> GO TO 2.

### 2. CHECK SECTOR GEAR POSITION LIMIT SWITCH (RH) SIGNAL CIRCUIT

1. Disconnect seatback power return control unit connector.
2. Check continuity between seatback power return control unit harness connector and sector gear position limit switch (RH) harness connector.

Seatback power return control unit		Sector gear position limit switch (RH)		Continuity
Connector	Terminal	Connector	Terminal	
B488	22	B495	1	Existed

3. Check continuity between seatback power return control unit harness connector and ground.

Seatback power return control unit		Ground	Continuity
Connector	Terminal		
B488	22		Not existed

Is the inspection result normal?

YES >> Replace seatback power return control unit. Refer to [SE-140, "Removal and Installation"](#).

NO >> Repair or replace harness.

### 3. CHECK SECTOR GEAR POSITION LIMIT SWITCH (RH) GROUND CIRCUIT

1. Disconnect seatback power return control unit connector and seatback angle limit switch (RH) connector.
2. Check continuity between seatback power return control unit harness connector and sector gear position limit switch (RH) harness connector.



# SECTOR GEAR POSITION LIMIT SWITCH

## < DTC/CIRCUIT DIAGNOSIS >

Seatback power return control unit		Sector gear position limit switch (RH)		Continuity
Connector	Terminal	Connector	Terminal	
B488	23	B495	2	Existed

3. Check continuity between seatback power return control unit harness connector and ground.

Seatback power return control unit		Ground	Continuity
Connector	Terminal		
B488	23		Not existed

Is the inspection result normal?

- YES >> GO TO 4.  
 NO >> Repair or replace harness.

### 4.CHECK SECTOR GEAR POSITION LIMIT SWITCH (RH)

Check sector gear position limit switch (RH).

Refer to [SE-65, "Component Inspection"](#).

Is the inspection result normal?

- YES >> GO TO 5.  
 NO >> Replace sector gear position limit switch (RH) [reclining device assembly (RH)]. Refer to [SE-123, "Exploded View"](#).

### 5.CHECK INTERMITTENT INCIDENT

Refer to [GI-42, "Intermittent Incident"](#).

>> INSPECTION END

## Component Inspection

INFOID:000000011325305

### COMPONENT INSPECTION

#### 1.CHECK SECTOR GEAR POSITION LIMIT SWITCH

- Turn ignition switch OFF.
- Disconnect sector gear position limit switch connector.
- Check sector gear position limit switch terminals under the following conditions.

Terminal		Condition	Continuity
1	2		
		Sector gear position limit switch	While being pressed Existed
			Other than the above Not existed

Is the inspection result normal?

- YES >> INSPECTION END  
 NO >> Replace sector gear limit switch (reclining device assembly). Refer to [SE-123, "Exploded View"](#).

A  
B  
C  
D  
E  
F  
G  
H  
I  
K  
L  
M  
N  
O  
P

SE

# POWER RETURN MOTOR

< DTC/CIRCUIT DIAGNOSIS >

## POWER RETURN MOTOR

LH

LH : Diagnosis Procedure

INFOID:000000011325306

### 1. CHECK POWER RETURN MOTOR (LH) INPUT SIGNAL

1. Turn ignition switch OFF.
2. Check voltage between power return motor assembly (LH) harness connector and ground.

(+)		(-)	Condition	Voltage (V)	
Power return motor assembly (LH)					
Connector	Terminal				
B498	1	Ground	Power return motor assembly (LH)	Reverse operation	9 – 16
	5			Other than the above	0 – 0.5
				Return operation	9 – 16
	Other than the above			0 – 0.5	

Is the inspection result normal?

- YES >> GO TO 3.  
NO >> GO TO 2.

### 2. CHECK POWER RETURN MOTOR (LH) CIRCUIT

1. Disconnect seatback power return control unit connector and power return motor assembly (LH) connector.
2. Check continuity between seatback power return control unit harness connector and power return motor assembly (LH) harness connector.

Seatback power return control unit		Power return motor assembly (LH)		Continuity
Connector	Terminal	Connector	Terminal	
B487	5	B498	1	Existed
	6		5	

3. Check continuity between seatback power return control unit harness connector and ground.

Seatback power return control unit		Ground	Continuity
Connector	Terminal		
B487	5		Not existed
	6		

Is the inspection result normal?

- YES >> Replace seatback power return control unit. Refer to [SE-140, "Removal and Installation"](#).  
NO >> Repair or replace harness.

### 3. CHECK INTERMITTENT INCIDENT

Check intermittent incident. Refer to [GI-42, "Intermittent Incident"](#).

Is the inspection result normal?

- YES >> Replace power return motor assembly (LH) [reclining device assembly (LH)]. Refer to [SE-123, "Exploded View"](#).  
NO >> Repair or replace harness.

RH

RH : Diagnosis Procedure

INFOID:000000011325307

### 1. CHECK POWER RETURN MOTOR (RH) INPUT SIGNAL

1. Turn ignition switch OFF.

# POWER RETURN MOTOR

## < DTC/CIRCUIT DIAGNOSIS >

- Check voltage between power return motor assembly (RH) harness connector and ground.

(+)		(-)	Condition	Voltage (V)	
Power return motor assembly (RH)					
Connector	Terminal				
B494	1	Ground	Power return motor assembly (RH)	Reverse operation	9 – 16
	5			Other than the above	0 – 0.5
				Return operation	9 – 16
				Other than the above	0 – 0.5

Is the inspection result normal?

YES >> GO TO 3.

NO >> GO TO 2.

## 2.CHECK POWER RETURN MOTOR (RH) CIRCUIT

- Disconnect seatback power return control unit connector and power return motor assembly (RH) connector.
- Check continuity between seatback power return control unit harness connector and power return motor assembly (RH) harness connector.

Seatback power return control unit		Power return motor assembly (RH)		Continuity
Connector	Terminal	Connector	Terminal	
B487	7	B494	1	Existed
	8		5	

- Check continuity between seatback power return control unit harness connector and ground.

Seatback power return control unit		Ground	Continuity
Connector	Terminal		
B487	7		Ground
	8		

Is the inspection result normal?

YES >> Replace seatback power return control unit. Refer to [SE-140. "Removal and Installation"](#).

NO >> Repair or replace harness.

## 3.CHECK INTERMITTENT INCIDENT

Check intermittent incident. Refer to [GI-42. "Intermittent Incident"](#).

Is the inspection result normal?

YES >> Replace power return motor assembly (RH) [reclining device assembly (RH)]. Refer to [SE-123. "Exploded View"](#).

NO >> Repair or replace harness.

# MOTOR SENSOR

< DTC/CIRCUIT DIAGNOSIS >

## MOTOR SENSOR

LH

LH : Diagnosis Procedure

INFOID:000000011325308

### 1. CHECK MOTOR SENSOR (LH) POWER SUPPLY

1. Turn ignition switch OFF.
2. Disconnect power return motor assembly (LH) connector.
3. Check voltage between power return motor assembly (LH) harness connector and ground.

(+)		(-)	Condition	Voltage (V)
Connector	Terminal			
B498	6	Ground	When power return motor (LH) is operated	9 – 16

Is the inspection result normal?

YES >> GO TO 3.

NO >> GO TO 2.

### 2. CHECK MOTOR SENSOR (LH) POWER SUPPLY CIRCUIT

1. Disconnect seatback power return control unit connector.
2. Check continuity between seatback power return control unit harness connector and power return motor assembly (LH) harness connector.

Seatback power return control unit		Power return motor assembly (LH)		Continuity
Connector	Terminal	Connector	Terminal	
B487	11	B498	6	Existed

3. Check continuity between seatback power return control unit harness connector and ground.

Seatback power return control unit		Ground	Continuity
Connector	Terminal		
B487	11		Not existed

Is the inspection result normal?

YES >> Replace seatback power return control unit. Refer to [SE-140. "Removal and Installation"](#).

NO >> Repair or replace harness.

### 3. CHECK MOTOR SENSOR (LH) GROUND CIRCUIT

1. Check continuity between seatback power return control unit harness connector and power return motor assembly (LH) harness connector.

Seatback power return control unit		Power return motor assembly (LH)		Continuity
Connector	Terminal	Connector	Terminal	
B487	9	B498	4	Existed

2. Check continuity between seatback power return control unit harness connector and ground.

Seatback power return control unit		Ground	Continuity
Connector	Terminal		
B487	9		Not existed

Is the inspection result normal?

YES >> GO TO 4.

NO >> Repair or replace harness.

### 4. CHECK MOTOR SENSOR (LH) OUTPUT SIGNAL

# MOTOR SENSOR

## < DTC/CIRCUIT DIAGNOSIS >

1. Connect seatback power return control unit connector.
2. Check signal between seatback power return control unit harness connector and ground with an oscilloscope.

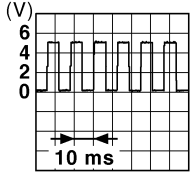
(+)		(-)	Condition	Signal (Reference value)
Seatback power return control unit Connector	Terminal			
B487	10	Ground	During the power return motor (LH) operation	 <p>JMKIA0070GB</p>
			When pinching of seatback occurs	

Is the inspection result normal?

- YES >> GO TO 6.  
NO >> GO TO 5.

## 5.CHECK MOTOR SENSOR (LH) SIGNAL CIRCUIT

1. Disconnect power return motor assembly (LH) connector and seatback power return control unit connector.
2. Check continuity between power return motor assembly (LH) harness connector and seatback power return control unit harness connector.

Seatback power return control unit		Power return motor assembly (LH)		Continuity
Connector	Terminal	Connector	Terminal	
B487	10	B498	3	Existed

3. Check continuity between power return motor assembly (LH) harness connector and ground.

Seatback power return control unit		Ground	Continuity
Connector	Terminal		
B487	10		Not existed

Is the inspection result normal?

- YES >> Replace power return motor assembly (LH) [reclining device assembly (LH)]. Refer to [SE-123](#), "[Exploded View](#)".  
NO >> Repair or replace harness.

## 6.CHECK INTERMITTENT INCIDENT

Refer to [GI-42](#), "[Intermittent Incident](#)".

>> INSPECTION END

RH

RH : Diagnosis Procedure

INFOID:0000000011325309

## 1.CHECK MOTOR SENSOR (RH) POWER SUPPLY

1. Turn ignition switch OFF.
2. Disconnect power return motor assembly (RH) connector.
3. Check voltage between power return motor assembly (RH) harness connector and ground.

# MOTOR SENSOR

## < DTC/CIRCUIT DIAGNOSIS >

(+)		(-)	Condition	Voltage (V)
Power return motor assembly (RH)				
Connector	Terminal			
B494	6	Ground	When power return motor (RH) is operated	9 – 16

Is the inspection result normal?

YES >> GO TO 3.

NO >> GO TO 2.

### 2.CHECK MOTOR SENSOR (RH) POWER SUPPLY CIRCUIT

1. Disconnect seatback power return control unit connector.
2. Check continuity between seatback power return control unit harness connector and power return motor assembly (RH) harness connector.

Seatback power return control unit		Power return motor assembly (RH)		Continuity
Connector	Terminal	Connector	Terminal	
B487	3	B494	6	Existed

3. Check continuity between seatback power return control unit harness connector and ground.

Seatback power return control unit		Ground	Continuity
Connector	Terminal		
B487	3		Not existed

Is the inspection result normal?

YES >> Replace seatback power return control unit. Refer to [SE-140. "Removal and Installation"](#).

NO >> Repair or replace harness.

### 3.CHECK MOTOR SENSOR (RH) GROUND CIRCUIT

1. Check continuity between seatback power return control unit harness connector and power return motor assembly (RH) harness connector.

Seatback power return control unit		Power return motor assembly (RH)		Continuity
Connector	Terminal	Connector	Terminal	
B487	1	B494	4	Existed

2. Check continuity between seatback power return control unit harness connector and ground.

Seatback power return control unit		Ground	Continuity
Connector			
B487	1		Not existed

Is the inspection result normal?

YES >> GO TO 4.

NO >> Repair or replace harness.

### 4.CHECK MOTOR SENSOR (RH) OUTPUT SIGNAL

1. Connect seatback power return control unit connector.
2. Check signal between seatback power return control unit harness connector and ground with an oscilloscope.

# MOTOR SENSOR

## < DTC/CIRCUIT DIAGNOSIS >

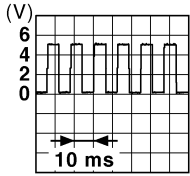
(+)		(-)	Condition	Signal (Reference value)
Seatback power return control unit				
Connector	Terminal			
B487	2	Ground	During the power return motor (RH) operation	
			When pinching seatback occurs	

Is the inspection result normal?

YES >> GO TO 6.

NO >> GO TO 5.

### 5. CHECK MOTOR SENSOR (RH) SIGNAL CIRCUIT

1. Disconnect power return motor assembly (RH) connector and seatback power return control unit connector.
2. Check continuity between power return motor assembly (RH) harness connector and seatback power return control unit harness connector.

Seatback power return control unit		Power return motor assembly (RH)		Continuity
Connector	Terminal	Connector	Terminal	
B487	2	B494	3	Existed

3. Check continuity between power return motor assembly (RH) harness connector and ground.

Seatback power return control unit		Ground	Continuity
Connector	Terminal		
B487	2		Not existed

Is the inspection result normal?

YES >> Replace power return motor assembly (RH) [reclining device assembly (RH)]. Refer to [SE-123](#), "[Exploded View](#)".

NO >> Repair or replace harness.

### 6. CHECK INTERMITTENT INCIDENT

Refer to [GI-42](#), "[Intermittent Incident](#)".

>> INSPECTION END

# SEATBACK DOES NOT OPERATE POWER RETURN

< SYMPTOM DIAGNOSIS >

## SYMPTOM DIAGNOSIS

### SEATBACK DOES NOT OPERATE POWER RETURN BOTH SIDES

#### BOTH SIDES : Diagnosis Procedure

INFOID:000000011325310

#### 1. CHECK POWER SUPPLY AND GROUND CIRCUIT

Check power supply and ground circuit.  
Refer to [SE-49, "Diagnosis Procedure"](#).

Is the inspection result normal?

- YES >> GO TO 2.
- NO >> Repair or replace the malfunctioning parts.

#### 2. CHECK VEHICLE SPEED SIGNAL CIRCUIT

Check vehicle speed signal circuit.  
Refer to [SE-55, "Diagnosis Procedure"](#).

Is the inspection result normal?

- YES >> GO TO 3.
- NO >> Repair or replace the malfunctioning parts.

#### 3. CONFIRM THE OPERATION

Confirm the operation again.

Is the inspection result normal?

- YES >> Check intermittent incident. Refer to [GI-42, "Intermittent Incident"](#).
- NO >> GO TO 1.

LH

#### LH : Diagnosis Procedure

INFOID:000000011325311

#### 1. CHECK THIRD SEAT FOLD SWITCH (LH)

Check third seat fold switch (LH).  
Refer to [SE-50, "LH : Component Function Check"](#).

Is the inspection result normal?

- YES >> GO TO 2.
- NO >> Repair or replace the malfunctioning parts.

#### 2. CHECK POWER RETURN MOTOR (LH)

Check power return motor (LH).  
Refer to [SE-66, "LH : Diagnosis Procedure"](#).

Is the inspection result normal?

- YES >> GO TO 3.
- NO >> Repair or replace the malfunctioning parts.

#### 3. CHECK SEATBACK ANGLE LIMIT SWITCH (LH)

Check seatback angle limit switch (LH).  
Refer to [SE-56, "LH : Diagnosis Procedure"](#).

Is the inspection result normal?

- YES >> GO TO 4.
- NO >> Repair or replace the malfunctioning parts.

#### 4. CONFIRM THE OPERATION

Confirm the operation again.

Is the result normal?

- YES >> Check intermittent incident. Refer to [GI-42, "Intermittent Incident"](#).



# SEATBACK DOES NOT OPERATE POWER RETURN

## < SYMPTOM DIAGNOSIS >

---

NO >> GO TO 1.

RH

RH : Diagnosis Procedure

INFOID:0000000011325312

### 1.CHECK THIRD SEAT FOLD SWITCH (RH)

---

Check third seat fold switch (RH).

Refer to [SE-52, "RH : Component Function Check"](#).

Is the inspection result normal?

YES >> GO TO 2.

NO >> Repair or replace the malfunctioning parts.

### 2.CHECK POWER RETURN MOTOR (RH)

---

Check power return motor (RH).

Refer to [SE-66, "RH : Diagnosis Procedure"](#).

Is the inspection result normal?

YES >> GO TO 3.

NO >> Repair or replace the malfunctioning parts.

### 3.CHECK SEATBACK ANGLE LIMIT SWITCH (RH)

---

Check seatback angle limit switch (RH).

Refer to [SE-57, "RH : Diagnosis Procedure"](#).

Is the inspection result normal?

YES >> GO TO 4.

NO >> Repair or replace the malfunctioning parts.

### 4.CONFIRM THE OPERATION

---

Confirm the operation again.

Is the result normal?

YES >> Check intermittent incident. Refer to [GI-42, "Intermittent Incident"](#).

NO >> GO TO 1.

A  
B  
C  
D  
E  
F  
G  
H  
I  
K  
L  
M  
N  
O  
P

SE

# DOES NOT RETURN BUT MALFUNCTION DETECTION BUZZER SOUNDS

< SYMPTOM DIAGNOSIS >

## DOES NOT RETURN BUT MALFUNCTION DETECTION BUZZER SOUNDS

LH

LH : Diagnosis Procedure

INFOID:0000000011325313

### 1. CHECK SECTOR GEAR POSITION LIMIT SWITCH (LH)

---

Check sector gear position limit switch (LH).  
Refer to [SE-63, "LH : Diagnosis Procedure"](#).

Is the inspection result normal?

- YES >> GO TO 2.
- NO >> Repair or replace the malfunctioning parts.

### 2. CHECK MOTOR SENSOR (LH)

---

Check motor sensor (LH).  
Refer to [SE-68, "LH : Diagnosis Procedure"](#).

Is the inspection result normal?

- YES >> GO TO 3.
- NO >> Repair or replace the malfunctioning parts.

### 3. CONFIRM THE OPERATION

---

Confirm the operation again.

Is the result normal?

- YES >> Check intermittent incident. Refer to [GI-42, "Intermittent Incident"](#).
- NO >> GO TO 1.

RH

RH : Diagnosis Procedure

INFOID:0000000011325314

### 1. CHECK SECTOR GEAR POSITION LIMIT SWITCH (RH)

---

Check sector gear position limit switch (RH).  
Refer to [SE-64, "RH : Diagnosis Procedure"](#).

Is the inspection result normal?

- YES >> GO TO 2.
- NO >> Repair or replace the malfunctioning parts.

### 2. CHECK MOTOR SENSOR (RH)

---

Check motor sensor (RH).  
Refer to [SE-69, "RH : Diagnosis Procedure"](#).

Is the inspection result normal?

- YES >> GO TO 3.
- NO >> Repair or replace the malfunctioning parts.

### 3. CONFIRM THE OPERATION

---

Confirm the operation again.

Is the result normal?

- YES >> Check intermittent incident. Refer to [GI-42, "Intermittent Incident"](#).
- NO >> GO TO 1.

# SEATBACK DOES NOT FOLD DOWN BY SWITCH OPERATION

< SYMPTOM DIAGNOSIS >

## SEATBACK DOES NOT FOLD DOWN BY SWITCH OPERATION BOTH SIDES

BOTH SIDES : Diagnosis Procedure

INFOID:0000000011325315

### 1.CHECK POWER SUPPLY AND GROUND CIRCUIT

Check power supply and ground circuit.  
Refer to [SE-49, "Diagnosis Procedure"](#).

Is the inspection result normal?

YES >> GO TO 2.

NO >> Repair or replace the malfunctioning parts.

### 2.CONFIRM THE OPERATION

Confirm the operation again.

Is the result normal?

YES >> Check intermittent incident. Refer to [GI-42, "Intermittent Incident"](#).

NO >> GO TO 1.

LH

LH : Diagnosis Procedure

INFOID:0000000011325316

### 1.CHECK THIRD SEAT FOLD SWITCH (LH)

Check third seat fold switch (LH).  
Refer to [SE-50, "LH : Component Function Check"](#).

Is the inspection result normal?

YES >> GO TO 2.

NO >> Repair or replace the malfunctioning parts.

### 2.CHECK SEATBACK LOCK RELEASE ACTUATOR (LH)

Check seatback lock release actuator (LH).  
Refer to [SE-59, "LH : Diagnosis Procedure"](#).

Is the inspection result normal?

YES >> GO TO 3.

NO >> Repair or replace the malfunctioning parts.

### 3.CONFIRM THE OPERATION.

Confirm the operation again.

Is the result normal?

YES >> Check intermittent incident. Refer to [GI-42, "Intermittent Incident"](#).

NO >> GO TO 1.

RH

RH : Diagnosis Procedure

INFOID:0000000011325317

### 1.CHECK THIRD SEAT FOLD SWITCH (RH)

Check third seat fold switch (RH).  
Refer to [SE-52, "RH : Component Function Check"](#).

Is the inspection result normal?

YES >> GO TO 2.

NO >> Repair or replace the malfunctioning parts.

### 2.CHECK SEATBACK LOCK RELEASE ACTUATOR (RH)

Check seatback lock release actuator (RH).  
Refer to [SE-60, "RH : Diagnosis Procedure"](#).

Is the inspection result normal?

## SEATBACK DOES NOT FOLD DOWN BY SWITCH OPERATION

< SYMPTOM DIAGNOSIS >

---

YES >> GO TO 3.

NO >> Repair or replace the malfunctioning parts.

**3.**CONFIRM THE OPERATION.

---

Confirm the operation again.

Is the result normal?

YES >> Check intermittent incident. Refer to [GI-42, "Intermittent Incident"](#).

NO >> GO TO 1.

# MALFUNCTION DETECTION BUZZER SOUNDS DURING POWER RETURN MOTOR INVERSE ROTATION

< SYMPTOM DIAGNOSIS >

## MALFUNCTION DETECTION BUZZER SOUNDS DURING POWER RETURN MOTOR INVERSE ROTATION LH

LH : Diagnosis Procedure

INFOID:000000011325318

### 1.CHECK SEATBACK ANGLE LIMIT SWITCH (LH)

Check seatback angle limit switch (LH).  
Refer to [SE-56. "LH : Diagnosis Procedure"](#).

Is the inspection result normal?

- YES >> GO TO 2.
- NO >> Repair or replace the malfunctioning parts.

### 2.CHECK SECTOR GEAR POSITION LIMIT SWITCH (LH)

Check sector gear position limit switch (LH).  
Refer to [SE-63. "LH : Diagnosis Procedure"](#).

Is the inspection result normal?

- YES >> GO TO 3.
- NO >> Repair or replace the malfunctioning parts.

### 3.CHECK POWER RETURN MOTOR (LH)

Check power return motor (LH).  
Refer to [SE-66. "LH : Diagnosis Procedure"](#).

Is the inspection result normal?

- YES >> GO TO 4.
- NO >> Repair or replace the malfunctioning parts.

### 4.CONFIRM THE OPERATION

Confirm the operation again.

Is the result normal?

- YES >> Check intermittent incident. Refer to [GI-42. "Intermittent Incident"](#).
- NO >> GO TO 1.

RH

RH : Diagnosis Procedure

INFOID:000000011325319

### 1.CHECK SEATBACK ANGLE LIMIT SWITCH (RH)

Check seatback angle limit switch (RH).  
Refer to [SE-57. "RH : Diagnosis Procedure"](#).

Is the inspection result normal?

- YES >> GO TO 2.
- NO >> Repair or replace the malfunctioning parts.

### 2.CHECK SECTOR GEAR POSITION LIMIT SWITCH (RH)

Check sector gear position limit switch (RH).  
Refer to [SE-65. "Component Inspection"](#).

Is the inspection result normal?

- YES >> GO TO 3.
- NO >> Repair or replace the malfunctioning parts.

### 3.CHECK POWER RETURN MOTOR (RH)

Check power return motor (RH).  
Refer to [SE-66. "RH : Diagnosis Procedure"](#).

Is the inspection result normal?

- YES >> GO TO 4.

# MALFUNCTION DETECTION BUZZER SOUNDS DURING POWER RETURN MOTOR INVERSE ROTATION

< SYMPTOM DIAGNOSIS >

---

NO >> Repair or replace the malfunctioning parts.

## 4. CONFIRM THE OPERATION

---

Confirm the operation again.

Is the result normal?

YES >> Check intermittent incident. Refer to [GI-42. "Intermittent Incident"](#).

NO >> GO TO 1.

# ANTI-PINCH FUNCTION DOES NOT OPERATE

< SYMPTOM DIAGNOSIS >

## ANTI-PINCH FUNCTION DOES NOT OPERATE

### Diagnosis Procedure

INFOID:000000011325320

#### 1.CHECK MOTOR SENSOR (LH)

Check motor sensor (LH).

Refer to [SE-68, "LH : Diagnosis Procedure"](#).

Is the inspection result normal?

YES >> GO TO 2.

NO >> Repair or replace the malfunctioning parts.

#### 2.CHECK MOTOR SENSOR (RH)

Check motor sensor (RH).

Refer to [SE-69, "RH : Diagnosis Procedure"](#).

Is the inspection result normal?

YES >> Replace seatback power return control unit. Refer to [SE-140, "Removal and Installation"](#).

NO >> Repair or replace the malfunctioning parts.

A  
B  
C  
D  
E  
F  
G  
H  
I  
K  
L  
M  
N  
O  
P

SE

# SQUEAK AND RATTLE TROUBLE DIAGNOSES

< SYMPTOM DIAGNOSIS >

## SQUEAK AND RATTLE TROUBLE DIAGNOSES

### Work Flow

INFOID:000000011325321

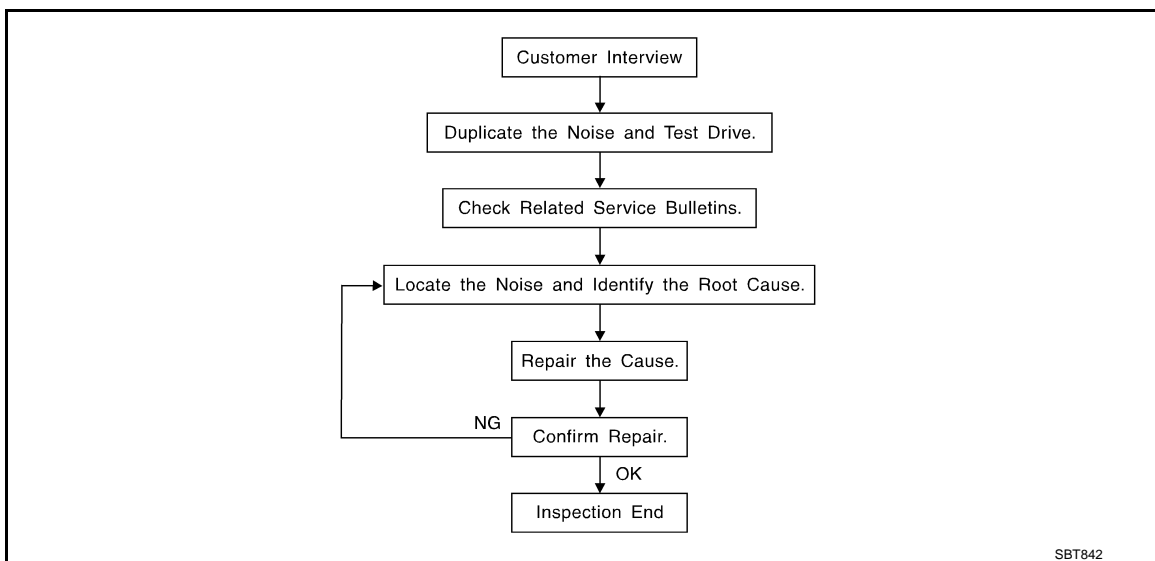

### CUSTOMER INTERVIEW

Interview the customer if possible, to determine the conditions that exist when the noise occurs. Use the Diagnostic Worksheet during the interview to document the facts and conditions when the noise occurs and any of customer's comments; refer to [SE-84, "Diagnostic Worksheet"](#). This information is necessary to duplicate the conditions that exist when the noise occurs.

- The customer may not be able to provide a detailed description or the location of the noise. Attempt to obtain all the facts and conditions that exist when the noise occurs (or does not occur).
- If there is more than one noise in the vehicle, perform a diagnosis and repair the noise that the customer is concerned about. This can be accomplished by performing a cruise test on the vehicle with the customer.
- After identifying the type of noise, isolate the noise in terms of its characteristics. The noise characteristics are provided so the customer, service adviser and technician are all speaking the same language when defining the noise.
- Squeak – (Like tennis shoes on a clean floor)  
Squeak characteristics include the light contact/fast movement/brought on by road conditions/hard surfaces = higher pitch noise/softer surfaces = lower pitch noises/edge to surface = chirping
- Creak – (Like walking on an old wooden floor)  
Creak characteristics include firm contact/slow movement/twisting with a rotational movement/pitch dependent on materials/often brought on by activity.
- Rattle – (Like shaking a baby rattle)  
Rattle characteristics include the fast repeated contact/vibration or similar movement/loose parts/missing clip or fastener/incorrect clearance.
- Knock – (Like a knock on a door)  
Knock characteristics include hollow sounding/sometimes repeating/often brought on by driver action.
- Tick – (Like a clock second hand)  
Tick characteristics include gentle contacting of light materials/loose components/can be caused by driver action or road conditions.
- Thump – (Heavy, muffled knock noise)  
Thump characteristics include softer knock/dead sound often brought on by activity.
- Buzz – (Like a bumblebee)  
Buzz characteristics include high frequency rattle/firm contact.
- Often the degree of acceptable noise level will vary depending up on the person. A noise that a technician may judge as acceptable may be very irritating to the customer.
- Weather conditions, especially humidity and temperature, may have a great effect on noise level.

### DUPLICATE THE NOISE AND TEST DRIVE

If possible, drive the vehicle with the customer until the noise is duplicated. Note any additional information on the Diagnostic Worksheet regarding the conditions or location of the noise. This information can be used to duplicate the same conditions when the repair is reconfirmed.



# SQUEAK AND RATTLE TROUBLE DIAGNOSES

## < SYMPTOM DIAGNOSIS >

If the noise can be duplicated easily during the test drive, to help identify the source of the noise, try to duplicate the noise with the vehicle stopped by doing one or all of the following:

- 1) Close a door.
  - 2) Tap or push/pull around the area where the noise appears to be coming from.
  - 3) Rev the engine.
  - 4) Use a floor jack to recreate vehicle "twist".
  - 5) At idle, apply engine load (electrical load, half-clutch on M/T models, drive position on A/T models).
  - 6) Raise the vehicle on a hoist and hit a tire with a rubber hammer.
- Drive the vehicle and attempt to duplicate the conditions the customer states exist when the noise occurs.
  - If it is difficult to duplicate the noise, drive the vehicle slowly on an undulating or rough road to stress the vehicle body.

## CHECK RELATED SERVICE BULLETINS

After verifying the customer concern or symptom, check ASIST for Technical Service Bulletins (TSBs) related to that concern or symptom.

If a TSB relates to the symptom, follow the procedure to repair the noise.

## LOCATE THE NOISE AND IDENTIFY THE ROOT CAUSE

1. Narrow down the noise to a general area. To help pinpoint the source of the noise, use a listening tool (Chassis ear: J-39570, Engine ear and mechanics stethoscope).
2. Narrow down the noise to a more specific area and identify the cause of the noise by:
  - Removing the components in the area that is are suspected to be the cause of the noise.  
Do not use too much force when removing clips and fasteners, otherwise clips and fastener can be broken or lost during the repair, resulting in the creation of new noise.
  - Tapping or pushing/pulling the component that is are suspected to be the cause of the noise.  
Do not tap or push/pull the component with excessive force, otherwise the noise will be eliminated only temporarily.
  - Feeling for a vibration by hand by touching the component(s) that is are suspected to be the cause of the noise.
  - Placing a piece of paper between components that are suspected to be the cause of the noise.
  - Looking for loose components and contact marks.  
Refer to [SE-82, "Inspection Procedure"](#).

## REPAIR THE CAUSE

- If the cause is a loose component, tighten the component securely.
- If the cause is insufficient clearance between components:
  - Separate components by repositioning or loosening and retightening the component, if possible.
  - Insulate components with a suitable insulator such as urethane pads, foam blocks, felt cloth tape or urethane tape. A Nissan Squeak and Rattle Kit (J-50397) is available through the authorized Nissan Parts Department.

### **CAUTION:**

**Never use excessive force as many components are constructed of plastic and may be damaged.**

### **NOTE:**

Always check with the Parts Department for the latest parts information.

The following materials are contained in the Nissan Squeak and Rattle Kit (J-50397). are listed on the inside cover of the kit, and can each be ordered separately as needed.

URETHANE PADS [1.5 mm (0.059 in) thick]

Insulates connectors, harness, etc.

76268-9E005: 100 × 135 mm (3.94 × 5.31 in)/76884-71L01: 60 × 85 mm (2.36 × 3.35 in)/76884-71L02: 15 × 25 mm (0.59 × 0.98 in)

INSULATOR (Foam blocks)

Insulates components from contact. Can be used to fill space behind a panel.

73982-9E000: 45 mm (1.77 in) thick, 50 × 50 mm (1.97 × 1.97 in)/73982-

50Y00: 10 mm (0.39 in) thick, 50 × 50 mm (1.97 × 1.97 in)

INSULATOR (Light foam block)

80845-71L00: 30 mm (1.18 in) thick, 30 × 50 mm (1.18 × 1.97in)

FELT CLOTHTAPE

Used to insulate where movement does not occur. Ideal for instrument panel applications.

68370-4B000: 15 × 25 mm (0.59 × 0.98 in) pad/68239-13E00: 5 mm (0.20 in) wide tape roll

The following materials, not found in the kit, can also be used to repair squeaks and rattles.

UHMW (TEFLON) TAPE

# SQUEAK AND RATTLE TROUBLE DIAGNOSES

## < SYMPTOM DIAGNOSIS >

---

Insulates where slight movement is present. Ideal for instrument panel applications.

### SILICONE GREASE

Used in place of UHMW tape that is be visible or does not fit. Will only last a few months.

### SILICONE SPRAY

Used when grease cannot be applied.

### DUCT TAPE

Used to eliminate movement.

## CONFIRM THE REPAIR

Confirm that the cause of a noise is repaired by test driving the vehicle. Operate the vehicle under the same conditions as when the noise originally occurred. Refer to the notes on the Diagnostic Worksheet.

## Inspection Procedure

INFOID:000000011325322

Refer to Table of Contents for specific component removal and installation information.

## INSTRUMENT PANEL

Most incidents are caused by contact and movement between:

1. The cluster lid A and instrument panel
2. Acrylic lens and combination meter housing
3. Instrument panel to front pillar garnish
4. Instrument panel to windshield
5. Instrument panel mounting pins
6. Wiring harnesses behind the combination meter
7. A/C defroster duct and duct joint

These incidents can usually be located by tapping or moving the components to duplicate the noise or by pressing on the components while driving to stop the noise. Most of these incidents can be repaired by applying felt cloth tape or silicon spray (in hard to reach areas). Urethane pads can be used to insulate wiring harness.

### **CAUTION:**

**Never use silicone spray to isolate a squeak or rattle. If the area is saturated with silicone, the recheck of repair becomes impossible.**

## CENTER CONSOLE

Components to pay attention to include:

1. Shifter assembly cover to finisher
2. A/C control unit and cluster lid C
3. Wiring harnesses behind audio and A/C control unit

The instrument panel repair and isolation procedures also apply to the center console.

## DOORS

Pay attention to the following:

1. Finisher and inner panel making a slapping noise
2. Inside handle escutcheon to door finisher
3. Wiring harnesses tapping
4. Door striker out of alignment causing a popping noise on starts and stops

Tapping or moving the components or pressing on them while driving to duplicate the conditions can isolate many of these incidents. The areas can usually be insulated with felt cloth tape or insulator foam blocks from the Nissan Squeak and Rattle Kit (J-50397) to repair the noise.

## TRUNK

Trunk noises are often caused by a loose jack or loose items put into the trunk by the customer.

In addition look for the following:

1. Trunk lid dumpers out of adjustment
2. Trunk lid striker out of adjustment
3. The trunk lid torsion bars knocking together
4. A loose license plate or bracket

# SQUEAK AND RATTLE TROUBLE DIAGNOSES

## < SYMPTOM DIAGNOSIS >

Most of these incidents can be repaired by adjusting, securing or insulating the item(s) or component(s) causing the noise.

### SUNROOF/HEADLINING

Noises in the sunroof/headlining area can often be traced to one of the following:

1. Sunroof lid, rail, linkage or seals making a rattle or light knocking noise
2. Sunvisor shaft shaking in the holder
3. Front or rear windshield touching headlining and squeaking

Again, pressing on the components to stop the noise while duplicating the conditions can isolate most of these incidents. Repairs usually consist of insulating with felt cloth tape.

### SEATS

When isolating seat noise it's important to note the position the seats in and the load placed on the seat when the noise occurs. These conditions should be duplicated when verifying and isolating the cause of the noise.

Cause of seat noise include:

1. Headrest rods and holder
2. A squeak between the seat pad cushion and frame
3. The rear seatback lock and bracket

These noises can be isolated by moving or pressing on the suspected components while duplicating the conditions under which the noise occurs. Most of these incidents can be repaired by repositioning the component or applying urethane tape to the contact area.

### UNDERHOOD

Some interior noise may be caused by components under the hood or on the engine wall. The noise is then transmitted into the passenger compartment.

Causes of transmitted underhood noise include:

1. Any component mounted to the engine wall
2. Components that pass through the engine wall
3. Engine wall mounts and connectors
4. Loose radiator mounting pins
5. Hood bumpers out of adjustment
6. Hood striker out of adjustment

These noises can be difficult to isolate since they cannot be reached from the interior of the vehicle. The best method is to secure, move or insulate one component at a time and test drive the vehicle. Also, engine RPM or load can be changed to isolate the noise. Repairs can usually be made by moving, adjusting, securing, or insulating the component causing the noise.

A  
B  
C  
D  
E  
F  
G  
H  
I  
K  
L  
M  
N  
O  
P

SE

# SQUEAK AND RATTLE TROUBLE DIAGNOSES

< SYMPTOM DIAGNOSIS >

## Diagnostic Worksheet

INFOID:000000011325323



### SQUEAK & RATTLE DIAGNOSTIC WORKSHEET

Dear Nissan Customer:

We are concerned about your satisfaction with your Nissan vehicle. Repairing a squeak or rattle sometimes can be very difficult. To help us fix your Nissan right the first time, please take a moment to note the area of the vehicle where the squeak or rattle occurs and under what conditions. You may be asked to take a test drive with a service advisor or technician to ensure we confirm the noise you are hearing.

#### I. WHERE DOES THE NOISE COME FROM? (circle the area of the vehicle)

The illustrations are for reference only, and may not reflect the actual configuration of your vehicle.

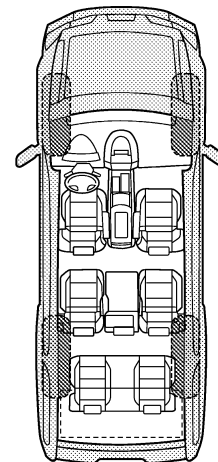
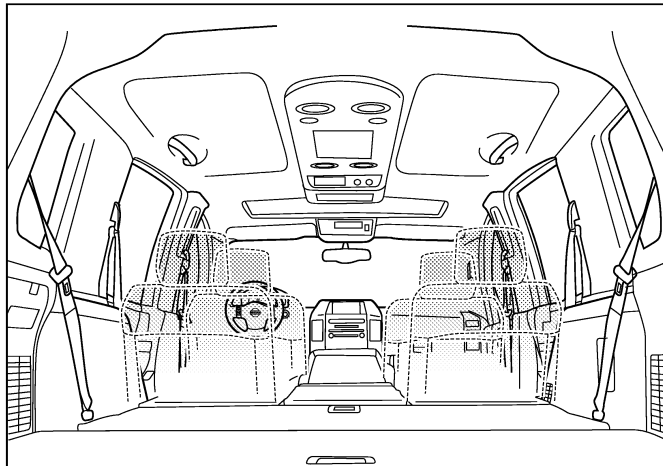
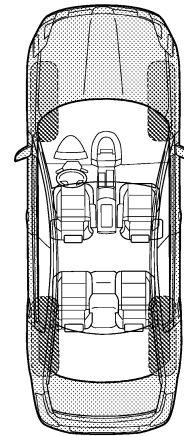
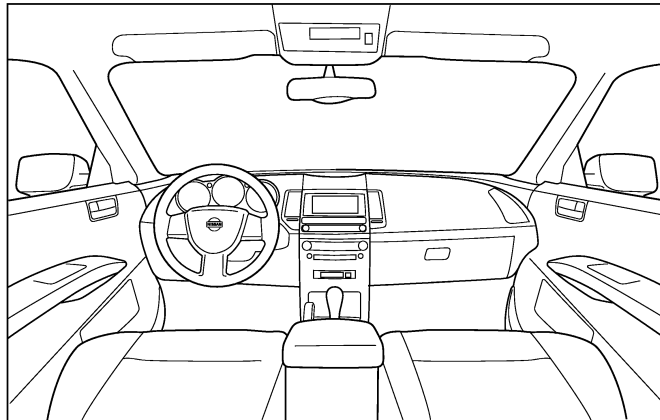

Continue to page 2 of the worksheet and briefly describe the location of the noise or rattle. In addition, please indicate the conditions which are present when the noise occurs.

PIIB8740E

# SQUEAK AND RATTLE TROUBLE DIAGNOSES

< SYMPTOM DIAGNOSIS >

## SQUEAK & RATTLE DIAGNOSTIC WORKSHEET - page 2

Briefly describe the location where the noise occurs:

---

---

### II. WHEN DOES IT OCCUR? (please check the boxes that apply)

- |   |  |
|---|--|
| <input type="checkbox"/> anytime                      | <input type="checkbox"/> after sitting out in the rain |
| <input type="checkbox"/> 1st time in the morning      | <input type="checkbox"/> when it is raining or wet     |
| <input type="checkbox"/> only when it is cold outside | <input type="checkbox"/> dry or dusty conditions       |
| <input type="checkbox"/> only when it is hot outside  | <input type="checkbox"/> other:                        |

### III. WHEN DRIVING:

- through driveways
- over rough roads
- over speed bumps
- only about \_\_\_\_ mph
- on acceleration
- coming to a stop
- on turns: left, right or either (circle)
- with passengers or cargo
- other: \_\_\_\_\_
- after driving \_\_\_\_ miles or \_\_\_\_ minutes

### IV. WHAT TYPE OF NOISE

- squeak (like tennis shoes on a clean floor)
- creak (like walking on an old wooden floor)
- rattle (like shaking a baby rattle)
- knock (like a knock at the door)
- tick (like a clock second hand)
- thump (heavy, muffled knock noise)
- buzz (like a bumble bee)

### TO BE COMPLETED BY DEALERSHIP PERSONNEL

#### Test Drive Notes:

---

---

---

	YES	NO	Initials of person performing
Vehicle test driven with customer	<input type="checkbox"/>	<input type="checkbox"/>	_____
- Noise verified on test drive	<input type="checkbox"/>	<input type="checkbox"/>	_____
- Noise source located and repaired	<input type="checkbox"/>	<input type="checkbox"/>	_____
- Follow up test drive performed to confirm repair	<input type="checkbox"/>	<input type="checkbox"/>	_____

VIN: \_\_\_\_\_ Customer Name: \_\_\_\_\_  
W.O.# \_\_\_\_\_ Date: \_\_\_\_\_

This form must be attached to Work Order

PIIB8742E

A  
B  
C  
D  
E  
F  
G  
H  
I  
SE  
K  
L  
M  
N  
O  
P

# FRONT SEAT (MANUAL SEAT)

< REMOVAL AND INSTALLATION >

## REMOVAL AND INSTALLATION

### FRONT SEAT (MANUAL SEAT)

Exploded View

INFOID:000000011325324

DRIVER SEAT

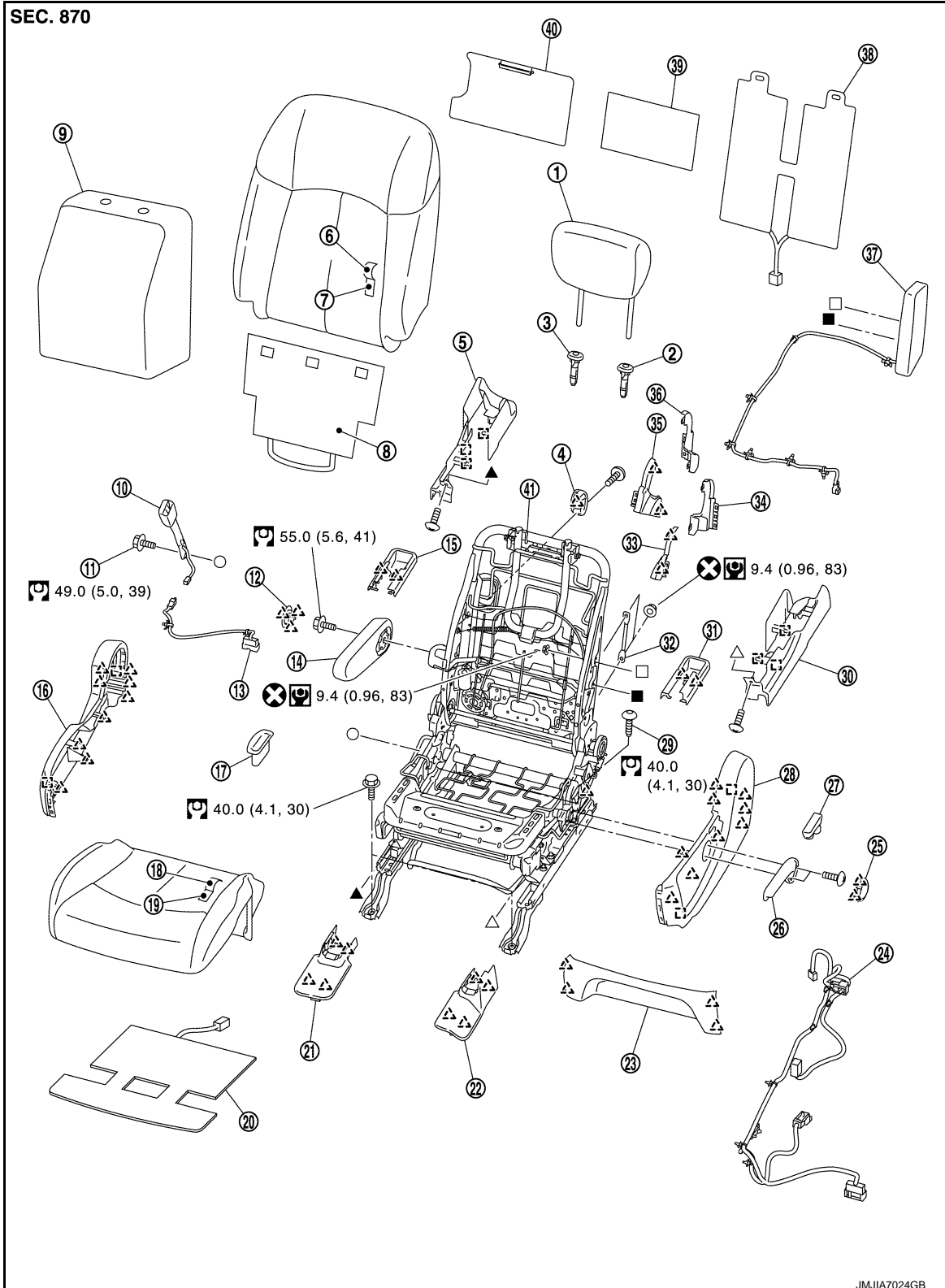

# FRONT SEAT (MANUAL SEAT)

## < REMOVAL AND INSTALLATION >

- |   |  |  |   |
|---|--|--|---|
| 1. Headrest                             | 2. Headrest holder (locked)              | 3. Headrest holder (free)                | A |
| 4. Seatback hook assembly               | 5. Lower inner finisher                  | 6. Seatback trim                         |   |
| 7. Seatback pad                         | 8. Seatback lower carpet                 | 9. Seatback silencer                     |   |
| 10. Seat belt buckle                    | 11. Anchor bolt                          | 12. Armrest cap                          | B |
| 13. Seat belt buckle harness            | 14. Armrest assembly                     | 15. Seat slide rear inner cover          |   |
| 16. Seat cushion inner finisher         | 17. Seat belt buckle trim                | 18. Seat cushion trim                    |   |
| 19. Seat cushion pad                    | 20. Seat cushion heater unit*            | 21. Seat slide front inner cover         | C |
| 22. Seat slide front outer cover        | 23. Seat cushion finisher                | 24. Seat harness assembly                |   |
| 25. Seat lifter lever knob cap          | 26. Seat lifter lever knob               | 27. Seat reclining lever knob            |   |
| 28. Seat cushion outer finisher         | 29. TORX bolt                            | 30. Lower outer finisher                 | D |
| 31. Seat slide rear outer cover         | 32. Side air bag rod                     | 33. Reclining device outer cover (front) |   |
| 34. Reclining device outer cover (rear) | 35. Reclining device inner cover (front) | 36. Reclining device inner cover (rear)  |   |
| 37. Side air bag module                 | 38. Seatback heater unit*                | 39. Seatback felt                        | E |
| 40. Seatback board                      | 41. Seat frame & adjuster assembly       |  |   |



: Pawl



: Metal clip



: Always replace after every disassembly.



: N·m (kg·m, ft·lb)



: N·m (kg·m, in·lb)



●, ▲, ○, △, □: Indicates that the part is connected at points with same symbol in actual vehicle.

\*: Only for seat with heater unit.

## PASSENGER SEAT

SE

K

L

M

N

O

P

# FRONT SEAT (MANUAL SEAT)

< REMOVAL AND INSTALLATION >

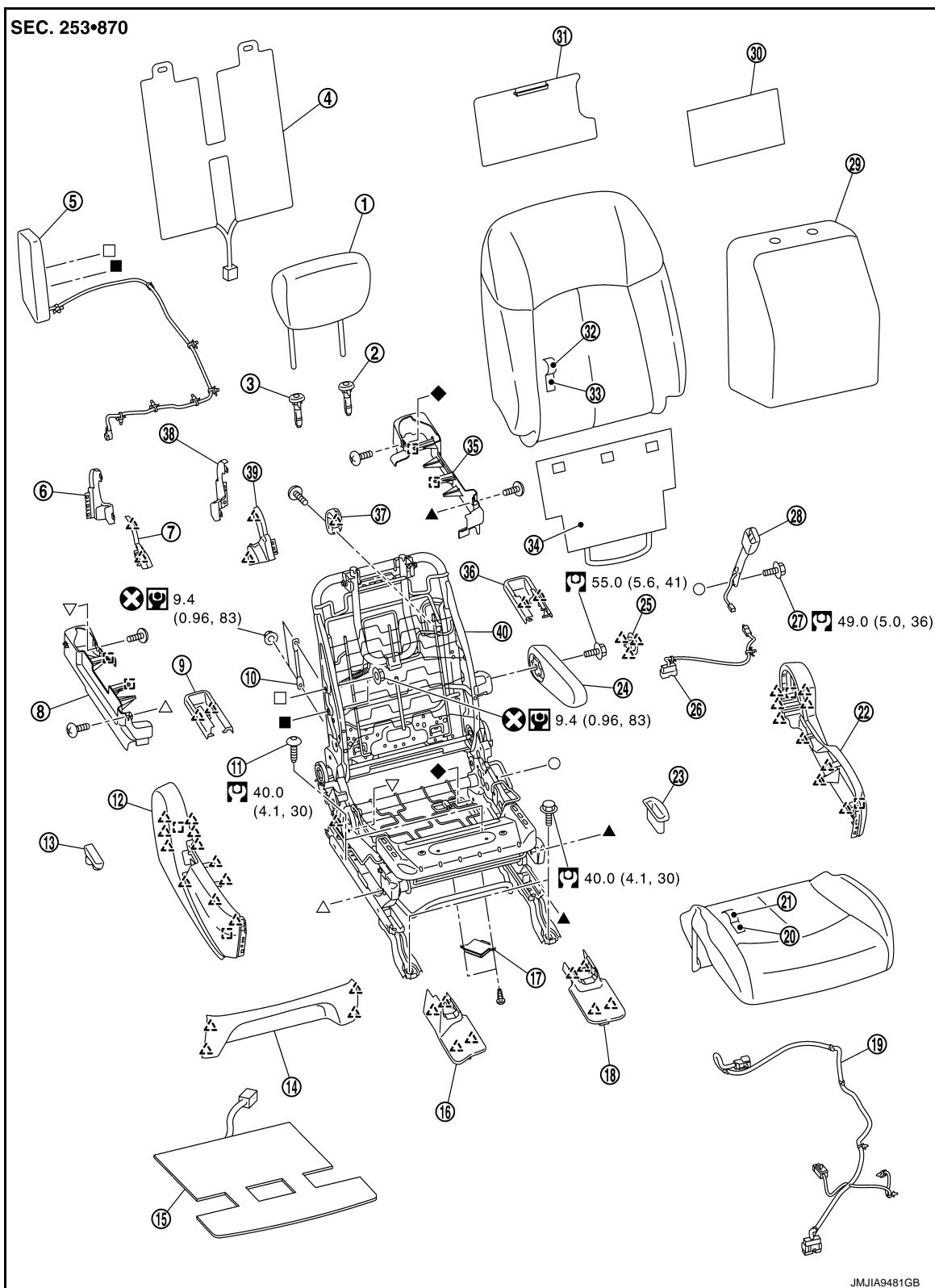

- |   |                             |  |
|---|-----------------------------|--|
| 1. Headrest                             | 2. Headrest holder (locked) | 3. Headrest holder (free)              |
| 4. Seatback heater unit*                | 5. Side air bag module      | 6. Reclining device outer cover (rear) |
| 7. Reclining device outer cover (front) | 8. Lower outer finisher     | 9. Seat slide rear outer cover         |
| 10. Side air bag rod                    | 11. TORX bolt               | 12. Seat cushion outer finisher        |
| 13. Seat reclining lever knob           | 14. Seat cushion finisher   | 15. Seat cushion heater unit*          |



# FRONT SEAT (MANUAL SEAT)

## < REMOVAL AND INSTALLATION >

- |                                    |  |  |
|------------------------------------|--|--|
| 16. Seat slide front outer cover   | 17. Occupant detection system control unit | 18. Seat slide front inner cover         |
| 19. Seat harness assembly          | 20. Seat cushion pad                       | 21. Seat cushion trim                    |
| 22. Seat cushion inner finisher    | 23. Seat belt buckle trim                  | 24. Armrest assembly                     |
| 25. Armrest cap                    | 26. Seat belt buckle harness               | 27. Anchor bolt                          |
| 28. Seat belt buckle               | 29. Seatback silencer                      | 30. Seatback felt                        |
| 31. Seatback board                 | 32. Seatback trim                          | 33. Seatback pad                         |
| 34. Seatback lower carpet          | 35. Lower inner finisher                   | 36. Seat slide rear inner cover          |
| 37. Seatback hook assembly         | 38. Reclining device inner cover (rear)    | 39. Reclining device inner cover (front) |
| 40. Seat frame & adjuster assembly |  |  |

 : Pawl

 : Metal clip

 : Always after every disassembly.

 : N·m (kg-m, ft-lb)

 : N·m (kg-m, in-lb)

●, ▲, ◆, ○, △, □, ▽ : Indicates that the part is connected at points with same symbol in actual vehicle.

\*: Only for seat with heater unit.

## Removal and Installation

INFOID:000000011325325

### REMOVAL

#### **WARNING:**

**Before servicing, turn ignition switch OFF, disconnect battery negative terminal and wait 3 minutes or more.**

1. Remove headrest.
2. Operate seat slide lever and slide seat to the frontmost position.
3. Remove seat slide rear outer cover.
  - a. Disengage pawls on the rear side of seat slide rear outer cover.
  - b. Disengage pawls on the front side of seat slide rear outer cover.
  - c. Slide seat slide rear outer cover to the rear side to remove.

 : Pawl

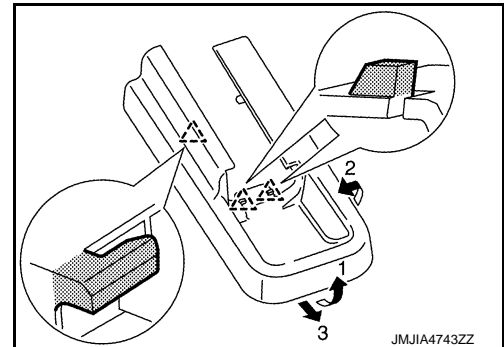

4. Remove seat slide rear inner cover.
  - a. Disengage pawls on the rear side of seat slide rear inner cover.
  - b. Disengage pawls on the front side of seat slide rear inner cover.
  - c. Slide seat slide rear inner cover to the rear side to remove.

 : Pawl

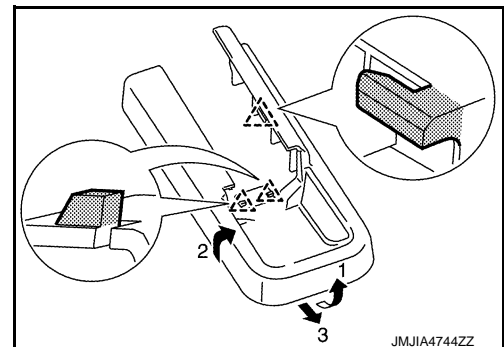

5. Remove rear outer mounting TORX bolt.
6. Remove rear inner mounting TORX bolt.

A  
B  
C  
D  
E  
F  
G  
H  
I  
SE  
K  
L  
M  
N  
O  
P

## FRONT SEAT (MANUAL SEAT)

### < REMOVAL AND INSTALLATION >

7. Operate seat slide lever and slide seat to the rearmost position.
8. Remove seat slide front outer cover.
  - a. Disengage pawls on the front side of seat slide front outer cover.
  - b. Disengage pawls on the rear side of seat slide front outer cover.
  - c. Slide seat slide front outer cover to the front side while lifting it upward to remove.

 : Pawl

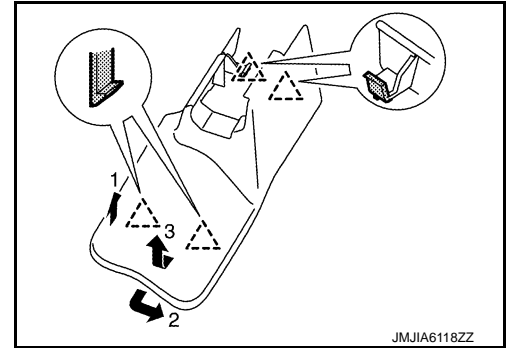

9. Remove seat slide front inner cover.
  - a. Disengage pawls on the front side of seat slide front inner cover.
  - b. Disengage pawls on the rear side of seat slide front inner cover.
  - c. Slide seat slide front inner cover to the front side while lifting it upward to remove.

 : Pawl

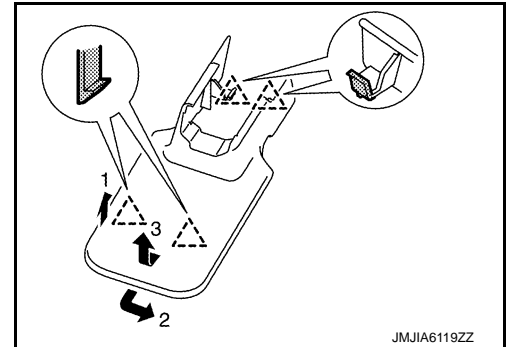

10. Remove front outer mounting bolt.
11. Remove front inner mounting bolt.
12. Operate seat reclining lever and set the seatback vertically.
13. Disconnect seat cushion lower harness connector, and then remove harness fixing clips.

#### **WARNING:**

**Never insert foreign materials, such as a screwdriver, into air bag module connector. (This is to prevent accidental activation caused by static electricity.)**

#### **CAUTION:**

**Before performing removal operation, check the installation position of harness connectors and harness fixing clamps.**

14. Remove seat from the vehicle.

#### **CAUTION:**

**When removing and installing, use shop cloths to protect parts from damage.**

### INSTALLATION

Note the following items, and install in the reverse order of removal.

#### **CAUTION:**

- When removing and installing, use shop cloths to protect parts from damage.
- Before installing seat, check that sliding rail inner and outer are locked in the same position.
- Before tightening bolts, check that the carpet is not caught in bolt holes on mounting portion.
- Always fix the harness fixing clamp in position.
- When connecting the connector, be sure to raise lock, and then push lock into the connector to fix. Check that the lock is engaged securely after connecting the connector.

# FRONT SEAT (MANUAL SEAT)

## < REMOVAL AND INSTALLATION >

- When installing, tighten mounting bolts to the specified torque according to the numerical order as shown in the figure, starting from front inner mounting bolt.  
For the specified torque, refer to [SE-86. "Exploded View"](#).

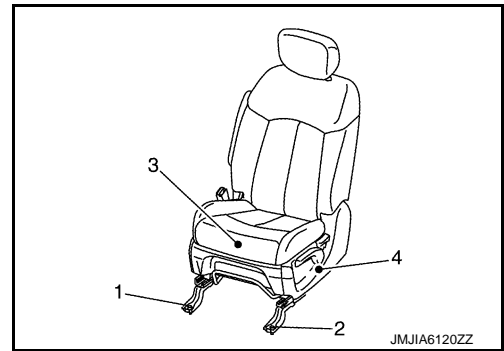

## SEATBACK

### SEATBACK : Disassembly and Assembly

INFOID:0000000011325326

#### DISASSEMBLY

1. Remove armrest assembly.
  - a. Disengage pawls and remove armrest cap.

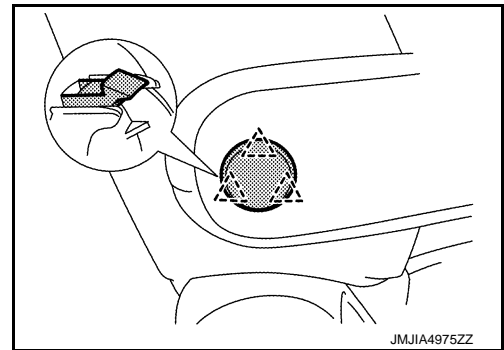
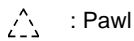

- b. Remove mounting bolt, and remove armrest assembly.
2. Remove the seatback retainer (A), and then open seatback fastener (B).
3. Roll up seatback trim, and then remove seatback retainer (C).

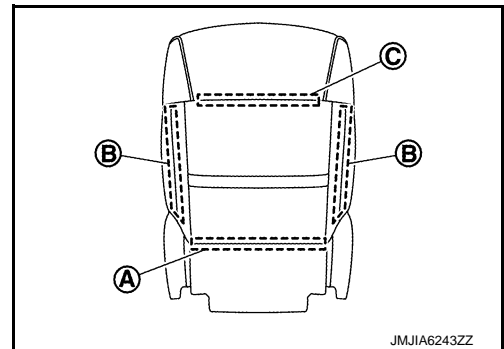

4. Remove side air bag module.
  - a. Remove seatback lower carpet from the seatback trim retainer.
  - b. Remove seatback trim retainer (A) and (B).

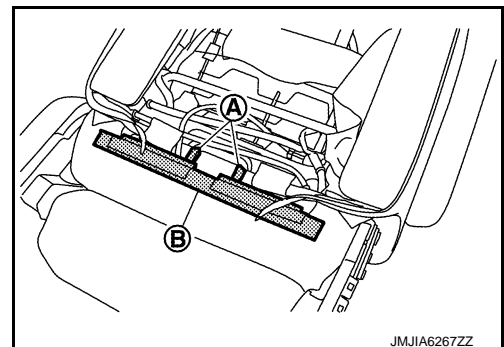

- c. Remove seat cushion lower side air bag module harness connector clip and side air bag module harness clip.

## FRONT SEAT (MANUAL SEAT)

### < REMOVAL AND INSTALLATION >

- d. Remove side air bag module harness clips from the seat frame & adjuster assembly.
- e. Pull out side air bag module harness (A) from the side or reclining device finisher.

 : Clip

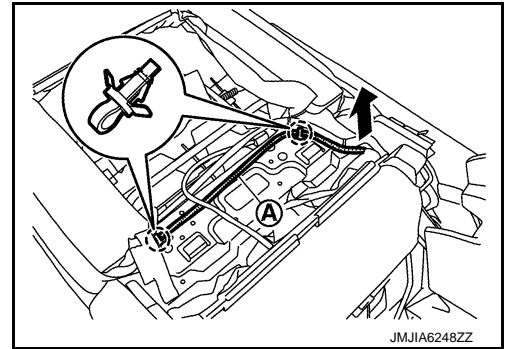

- f. Remove mounting nuts, and then remove side air bag rod from the seat frame & adjuster assembly.
- g. Pull up seatback pad (1) as shown in the figure and secure work space. Remove side air bag module (3) from the inner cloth (2).

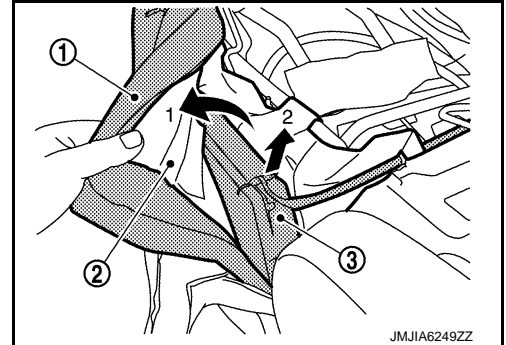

### CAUTION:

- Never damage seatback trim or inner cloth (reinforcement cloth).
- Check direction if side air bag module.
- Never disassemble and check inflator. Side air bag module must never be disassembled.
- To prevent damage to the parts, never impact the side air bag module.
- Replace the side air bag module if it is dropped or sustains an impact.

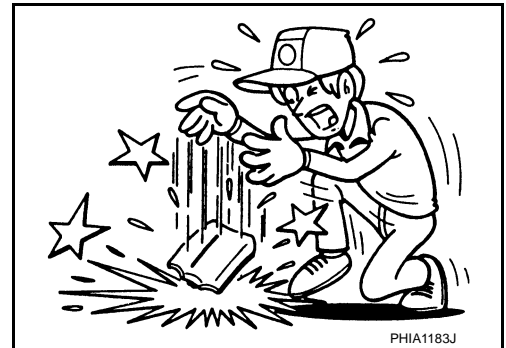

- To prevent accidental explosion, never expose the side air bag module to temperatures more than 90°C (194°F).
- Place air bag module as a unit with side air bag deployment surface facing upward (stud volts facing downward). (This is to prevent accidental deployment.)

5. Remove seatback hook assembly.
  - a. Rotate seatback hook to the position where fixing screw (A) can be removed, and then remove screw.
  - b. Pull seatback hook assembly forward, disengage pawl, and then remove seatback hook assembly from the seatback.

 : Pawl

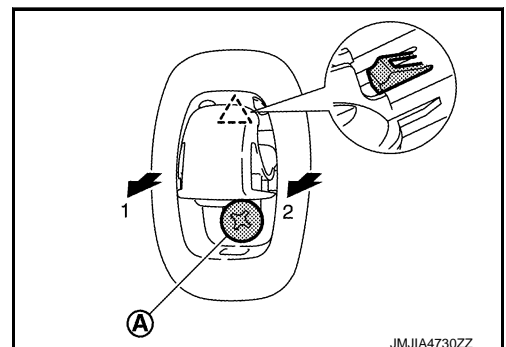

## FRONT SEAT (MANUAL SEAT)

### < REMOVAL AND INSTALLATION >

6. Disconnect seatback heater unit harness connector (A). (with heater seat only)

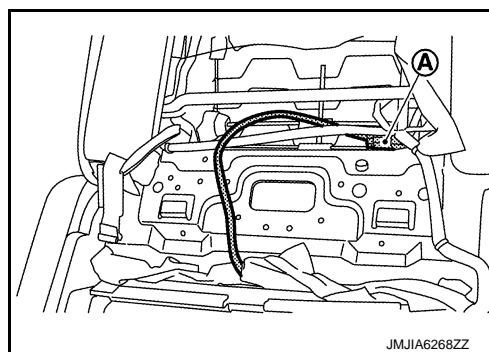

7. Remove the headrest holder from the seatback while pressing the pawls as shown by the arrows in the figure.

**CAUTION:**

**Before installing headrest holder check its orientation. (Front/rear and right/left)**

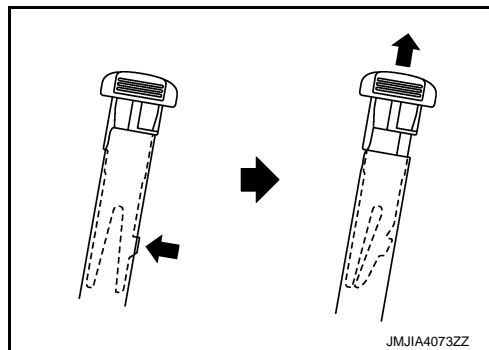

8. Remove seatback trim, seatback pad and seatback heater unit (with heater seat only) from seat frame & adjuster assembly.
9. Remove hog rings, and separate the seatback trim and seatback pad.  
**CAUTION:**  
**Before performing separating operation, check the installation position of hog rings.**
10. Separate the seatback pad and seatback heater unit. (with heater seat only)
11. Remove seatback silencer from seat frame & adjuster assembly.

### ASSEMBLY

Note the following, and assemble in the reverse order of disassembly.

**CAUTION:**

- Check the following parts for lubrication. Apply grease if necessary.

A  
B  
C  
D  
E  
F  
G  
H  
I  
SE  
K  
L  
M  
N  
O  
P

# FRONT SEAT (MANUAL SEAT)

## < REMOVAL AND INSTALLATION >

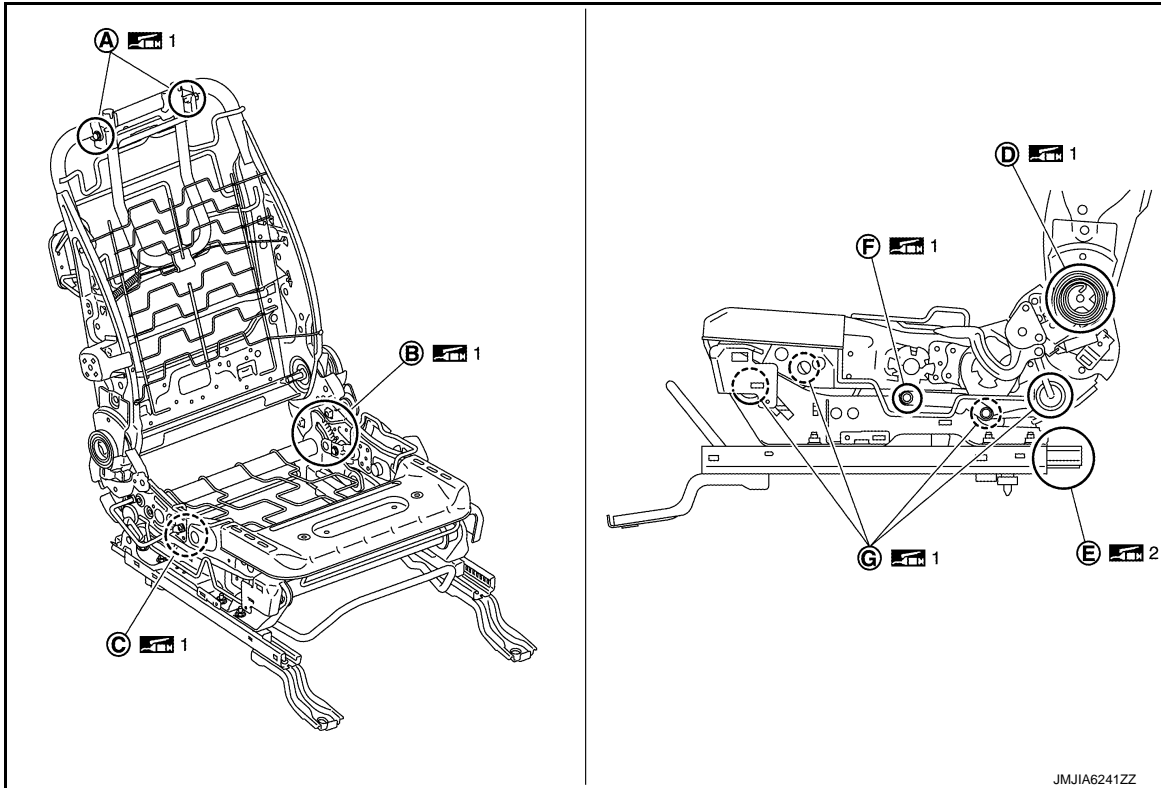

- A. Active headrest rotation engage SP
- B. Rear lifter link sliding portion
- C. Sector gear sliding portion
- D. Recliner base core sliding portion
- E. Slide rail sliding portion
- F. Lifter lever and lifter link sliding portion
- G. Seat lifter pipe (front and rear) crimp sliding portion

 : Heat-resistant and cold-resistant grease (Nippeco LLP or an equivalent)

 : Heat-resistant and cold-resistant grease (RHEOGEL or an equivalent)

- Check seatback pad and seatback trim for damage. Replace with new part if necessary.
- Install hog ring (A) to the specified position as shown in the figure.

B. hook and loop fastener

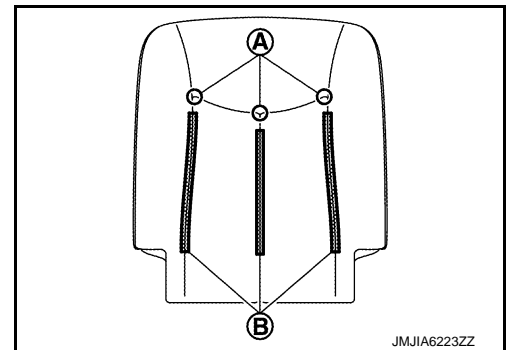

- If crimping using a hog ring is unsuccessful, using a new hog ring.
- Check that cutting slits on side air bag module cloth cover are not damaged. Replace side air bag module with a new one if necessary.
- Check that part number of the side air bag module is appropriate to seat specification.

# FRONT SEAT (MANUAL SEAT)

## < REMOVAL AND INSTALLATION >

- Check that side air bag module (1) and inner cloth (reinforcement cloth) (B) is in the position as shown in the figure.

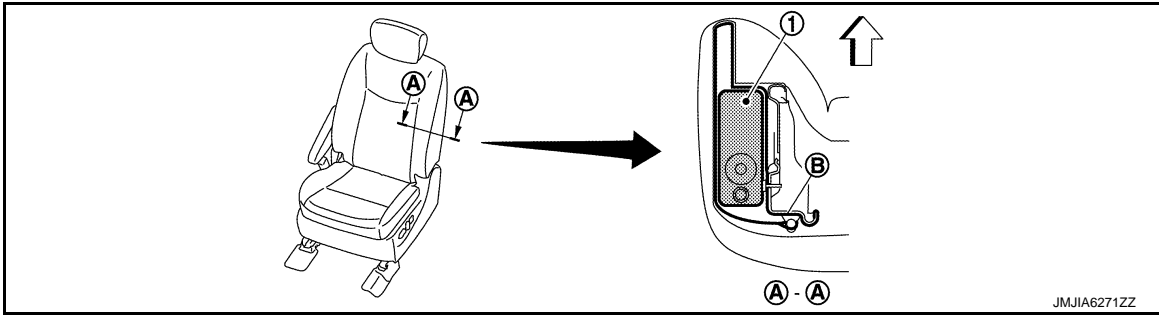

← : Vehicle front

- Check inner cloth (reinforcement cloth) for wrinkles and folding.
- Check that inner cloth (reinforcement cloth) is not pinched.
- Check that seatback trim and is fixed correctly.
- Never damage harness, connector, or clips of the side air bag module.
- Never damage seatback trim or inner cloth (reinforcement cloth).
- Check direction of side air bag module.
- Use new mounting nut when mounting the side air bag module. Tighten to the specified torque. For the specified torque, refer to [SE-86. "Exploded View"](#).
- Be careful not to leave any foreign materials (screwdriver or others) in seatback.
- Check that harness route and harness clip installation position are in the specified positions.
- When harness clip is damaged, mark the clip position and replace damaged clip with a new one in the original position.

## SEAT CUSHION

### SEAT CUSHION : Disassembly and Assembly

INFOID:000000011325327

#### DISASSEMBLY

Driver seat

#### NOTE:

When removing lower outer finisher or lower inner finisher, operate lifter lever and set seat cushion to the highest position in advance. This facilitates removal.

1. Pull seat cushion finisher forward, disengage pawls, and then remove seat cushion finisher.

△ : Pawl

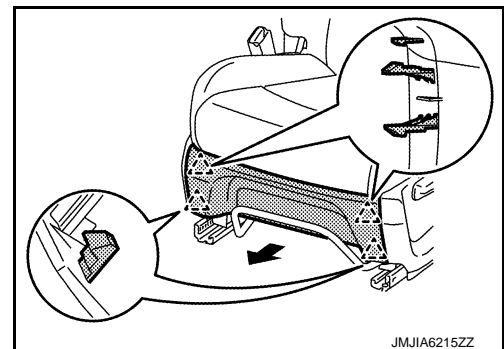

2. Remove seat cushion outer finisher.

## FRONT SEAT (MANUAL SEAT)

### < REMOVAL AND INSTALLATION >

- a. Disengage pawls and remove lifter lever knob cap (1).
- b. Remove fixing screws and remove lifter lever knob (2).

 : Pawl

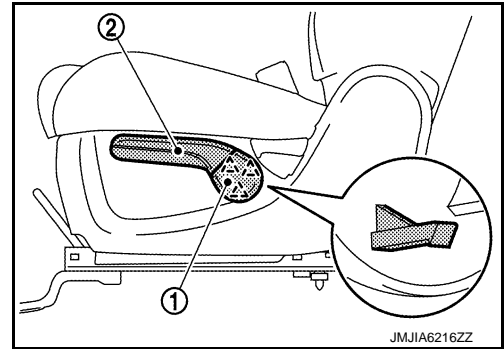

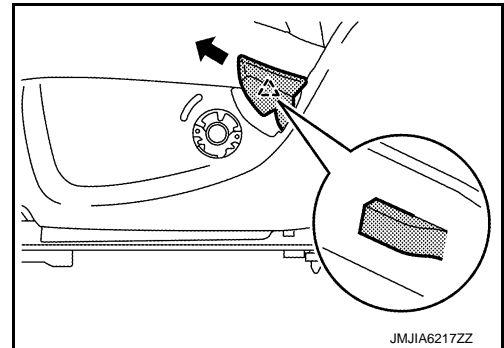

- c. Disengage pawls using a screwdriver while pulling seat reclining lever knob. Slide seat reclining lever knob toward seat front and remove it.

 : Pawl



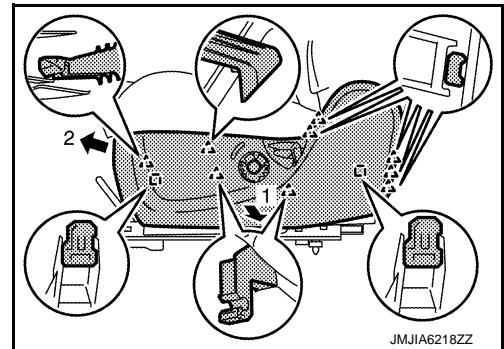

- d. Pull seat cushion outer finisher toward seat front. Disengage pawls and metal clips. Slide seat cushion outer finisher toward seat front. Remove seat cushion outer finisher.

 : Pawl  
 : Metal clip



3. Remove seat cushion inner finisher.  
 Pull seat cushion inner finisher toward seat front. Disengage pawls and metal clips. Slide seat cushion inner finisher upwards. Remove seat cushion inner finisher.

 : Pawl  
 : Metal clip

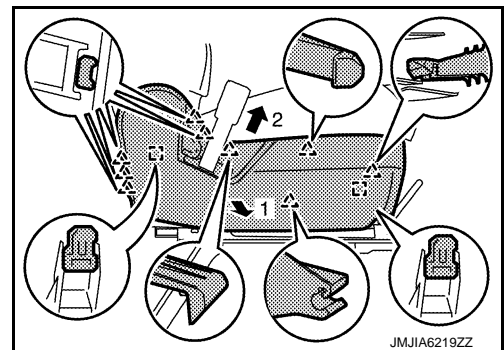

4. Remove seat cushion trim, seat cushion pad, and seat cushion heater unit (with heater seat only) from seat frame & adjuster assembly.



# FRONT SEAT (MANUAL SEAT)

## < REMOVAL AND INSTALLATION >

- a. Disconnect seat cushion heater unit harness connector (A) installed in the lower portion of seat cushion. (with heater seat only.)
- b. Remove seatback lower carpet rubber band (1) installed in the lower portion of seat cushion.

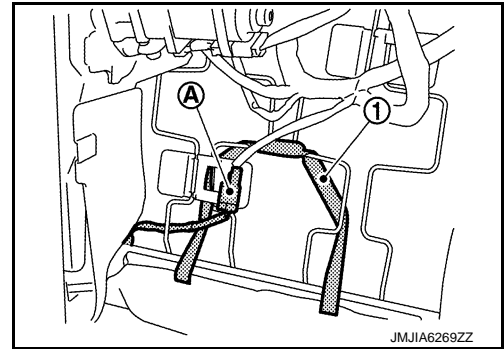

- c. Remove seat cushion trim retainer installed on seat frame & adjuster assembly.
- d. Remove seat cushion trim, seat cushion pad, and seat cushion heater unit (with heater seat only) from seat frame & adjuster assembly.
5. Remove hog rings, and separate the seat cushion trim and seat cushion pad.
 

**CAUTION:**  
Before performing separating operation, check the installation position of hog rings.
6. Separate the seat cushion pad and seat cushion heater unit. (with heater seat only)
7. Remove seatback trim and seatback pad from seat frame & adjuster assembly.  
Refer to [SE-91, "SEATBACK : Disassembly and Assembly"](#).
8. Remove reclining device cover.
  - Disengage pawls and remove reclining device outer cover (front and rear).
  - Disengage pawls and remove reclining device inner cover (front and rear).
9. Remove following parts from seat frame & adjuster assembly.
  - Remove lower outer finisher.
  - Remove lower inner finisher.
  - Remove seat belt buckle trim.
  - Remove seat belt buckle. Refer to [SB-9, "SEAT BELT BUCKLE : Removal and Installation"](#).
  - Remove seatback board.
  - Remove seatback felt.
  - Remove seat harness from seat frame & adjuster assembly.

### Passenger seat

1. Pull seat cushion finisher forward, disengage pawls, and then remove seat cushion finisher.

 : Pawl

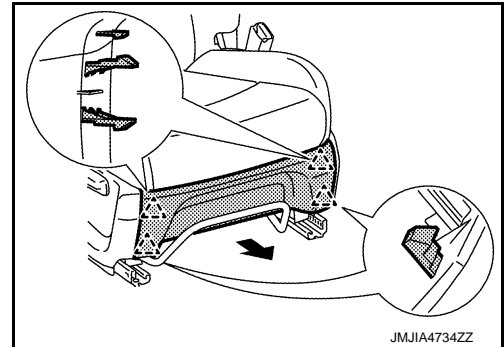

2. Remove seat cushion outer finisher.
  - a. Disengage pawls using a screwdriver while pulling seat reclining lever knob. Slide seat reclining lever knob toward seat front and remove it.

 : Pawl

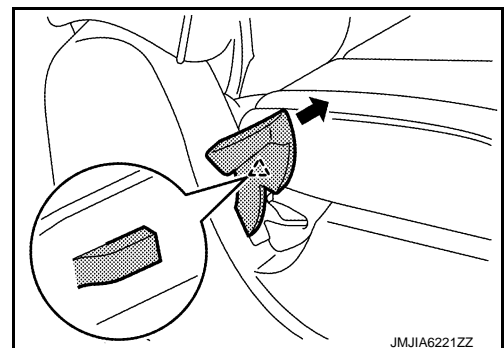

## FRONT SEAT (MANUAL SEAT)

### < REMOVAL AND INSTALLATION >

- b. Pull seat cushion outer finisher toward seat front. Disengage pawls and metal clips. Slide seat cushion outer finisher toward seat front. Remove seat cushion outer finisher.

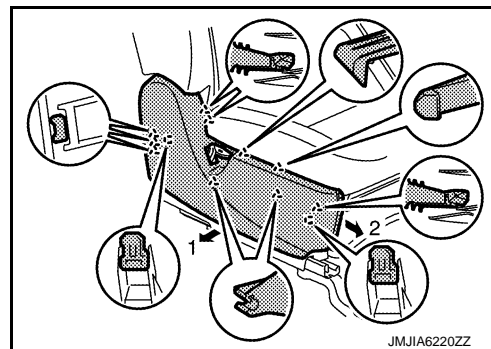
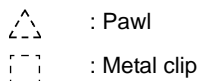

3. Pull seat cushion inner finisher toward seat front. Disengage pawls and metal clips. Slide seat cushion inner finisher upwards. Remove seat cushion inner finisher.

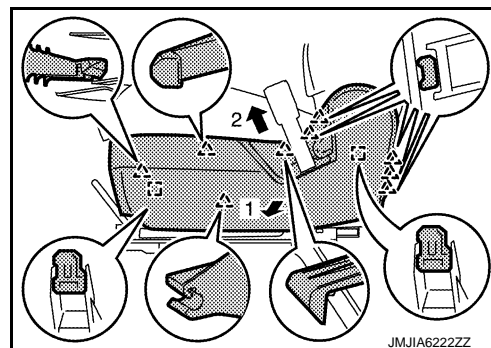
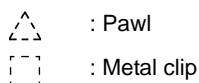

4. Remove seat cushion trim, seat cushion pad, and seat cushion heater unit (with heater seat only) from seat frame & adjuster assembly.

- a. Disconnect seat cushion heater unit harness connector (A) installed in the lower portion of seat cushion. (with heater seat only.)  
b. Remove seatback lower carpet rubber band (1) installed in the lower portion of seat cushion.

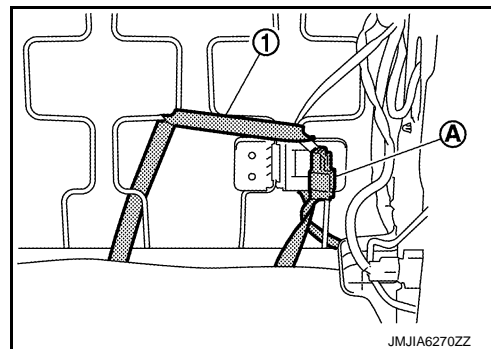

- c. Remove seat cushion trim, seat cushion pad, and seat cushion heater unit (with heater seat only) from seat frame & adjuster assembly.

5. Remove hog rings, and separate the seat cushion trim and seat cushion pad.

**CAUTION:**

**Before performing separating operation, check the installation position of hog rings.**

6. Separate the seat cushion pad and seat cushion heater unit. (with heater seat only)

7. Remove seatback trim and seatback pad from seat frame & adjuster assembly.

Refer to [SE-91, "SEATBACK : Disassembly and Assembly"](#).

8. Remove reclining device cover.

- Disengage pawls and remove reclining device outer cover (front and rear).
- Disengage pawls and remove reclining device inner cover (front and rear).

9. Remove following parts from seat frame & adjuster assembly.

- Remove lower outer finisher.
- Remove lower inner finisher.
- Remove seat belt buckle trim.
- Remove seat belt buckle. Refer to [SB-9, "SEAT BELT BUCKLE : Removal and Installation"](#).
- Remove seatback board.
- Remove seatback felt.
- Remove seat harness from seat frame & adjuster assembly.
- Remove occupant detection system control unit. Refer to [SR-32, "Removal and Installation"](#).

# FRONT SEAT (MANUAL SEAT)

## < REMOVAL AND INSTALLATION >

### ASSEMBLY

Note the following, and assemble in the reverse order of disassembly.

#### CAUTION:

- Check seat cushion trim and seat cushion pad for damage. Replace with new part if necessary.
- Install seat cushion front hog rings (A) and seat cushion back hog rings (B) to the specified positions.

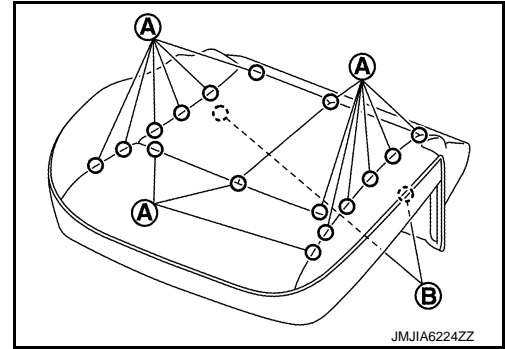

- Check the following parts for lubrication. Apply grease if necessary.

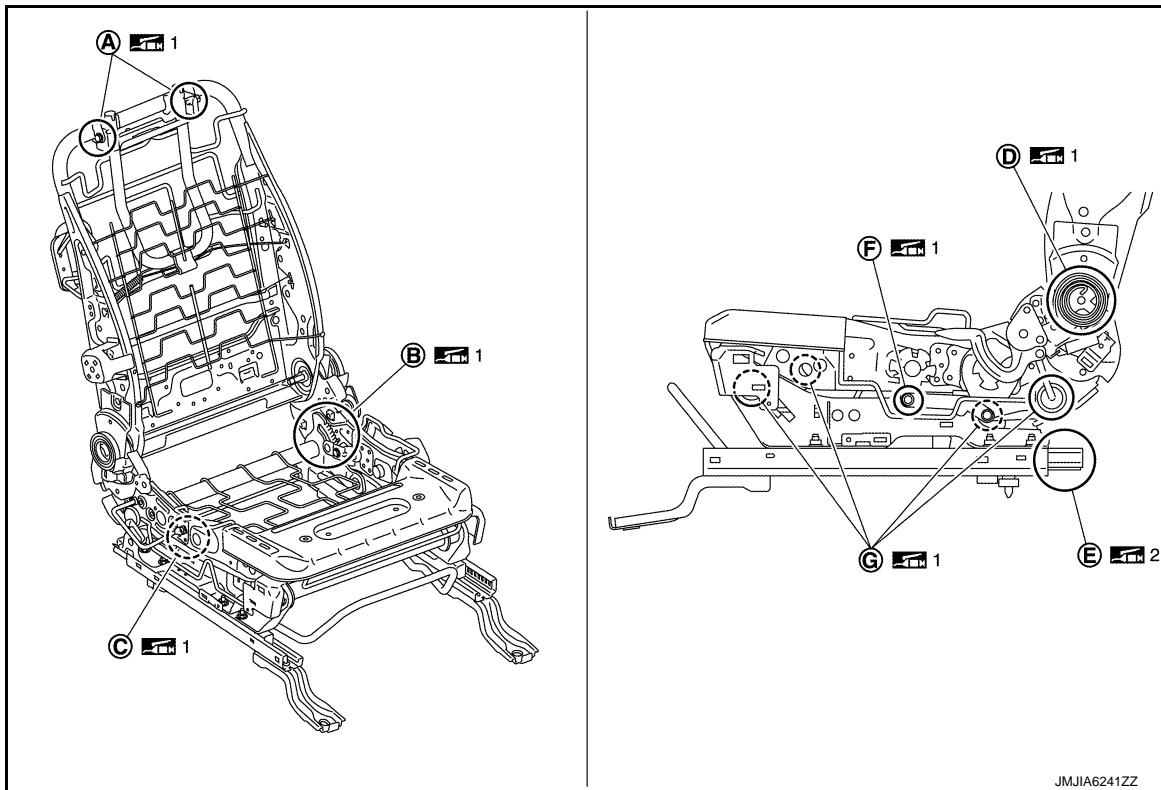

- |  |                                     |   |
|--|-------------------------------------|---|
| A. Active headrest rotation engage SP                      | B. Rear lifter link sliding portion | C. Sector gear sliding portion                  |
| D. Recliner base core sliding portion                      | E. Slide rail sliding portion       | F. Lifter lever and lifter link sliding portion |
| G. Seat lifter pipe (front and rear) crimp sliding portion |                                     |   |

 : Heat-resistant and cold-resistant grease (Nippeco LLP or an equivalent)

 : Heat-resistant and cold-resistant grease (RHEOGEL or an equivalent)

- If crimping using a hog ring is unsuccessful, secure using a new hog ring.
- Check that harness route and harness clip installation position are in the specified positions.
- When harness clip is damaged, mark the clip position and replace damaged clip with a new one in the original position.
- Tighten seat belt buckle anchor bolt to the specified torque.  
For the specified torque, refer to [SE-86. "Exploded View"](#).

# FRONT SEAT (POWER SEAT)

< REMOVAL AND INSTALLATION >

## FRONT SEAT (POWER SEAT)

Exploded View

INFOID:000000011325328

DRIVER SEAT

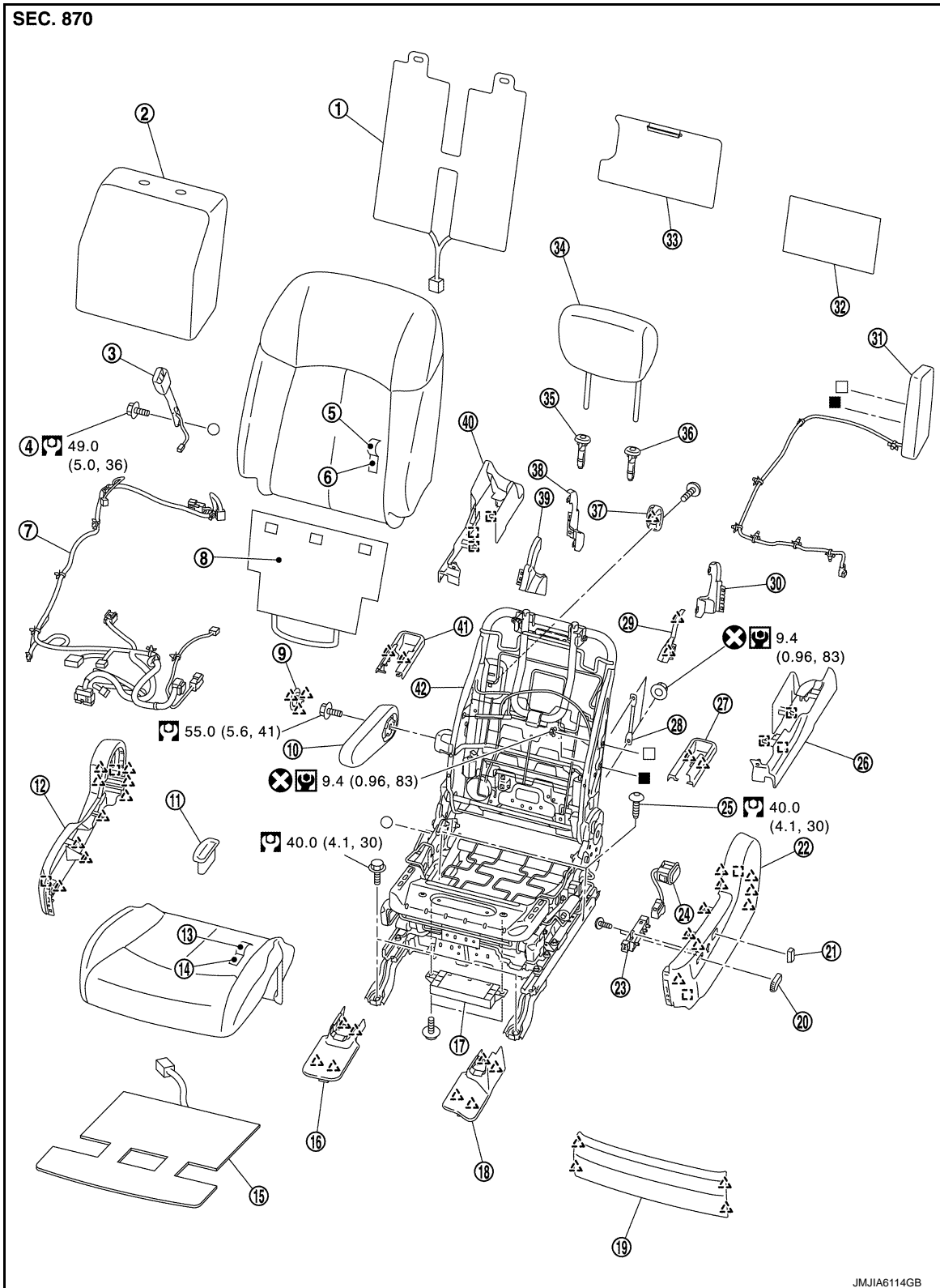

JMJA6114GB

# FRONT SEAT (POWER SEAT)

## < REMOVAL AND INSTALLATION >

- |                                  |  |  |   |
|----------------------------------|--|--|---|
| 1. Seatback heater unit          | 2. Seatback silencer                     | 3. Seat belt buckle                      | A |
| 4. Anchor bolt                   | 5. Seatback trim                         | 6. Seatback pad                          |   |
| 7. Seat harness assembly         | 8. Seatback lower carpet                 | 9. Armrest cap                           |   |
| 10. Armrest assembly             | 11. Seat belt buckle trim                | 12. Seat cushion inner finisher          | B |
| 13. Seat cushion trim            | 14. Seat cushion pad                     | 15. Seat cushion heater unit             |   |
| 16. Seat slide front inner cover | 17. Seat control unit                    | 18. Seat slide front outer cover         |   |
| 19. Seat cushion finisher        | 20. Seat slide & lifter switch knob      | 21. Seat reclining switch knob           | C |
| 22. Seat cushion outer finisher  | 23. Seat switch assembly                 | 24. Lumber support switch assembly       |   |
| 25. TORX bolt                    | 26. Lower outer finisher                 | 27. Seat slide rear outer cover          |   |
| 28. Side air bag rod             | 29. Reclining device outer cover (front) | 30. Reclining device outer cover (rear)  | D |
| 31. Side air bag module          | 32. Seatback felt                        | 33. Seatback board                       |   |
| 34. Headrest                     | 35. Headrest holder (free)               | 36. Headrest holder (locked)             |   |
| 37. Seatback hook assembly       | 38. Reclining device inner cover (rear)  | 39. Reclining device inner cover (front) | E |
| 40. Lower inner finisher         | 41. Seat slide rear inner cover          | 42. Seat frame & adjuster assembly       |   |



 : Pawl

 : Metal clip

 : Always replace after every disassembly.

 : N·m (kg-m, ft-lb)

 : N·m (kg-m, in-lb)

 ,  ,  : Indicates that the part is connected at points with same symbol in actual vehicle.

## PASSENGER SEAT

SE

K

L

M

N

O

P

# FRONT SEAT (POWER SEAT)

< REMOVAL AND INSTALLATION >

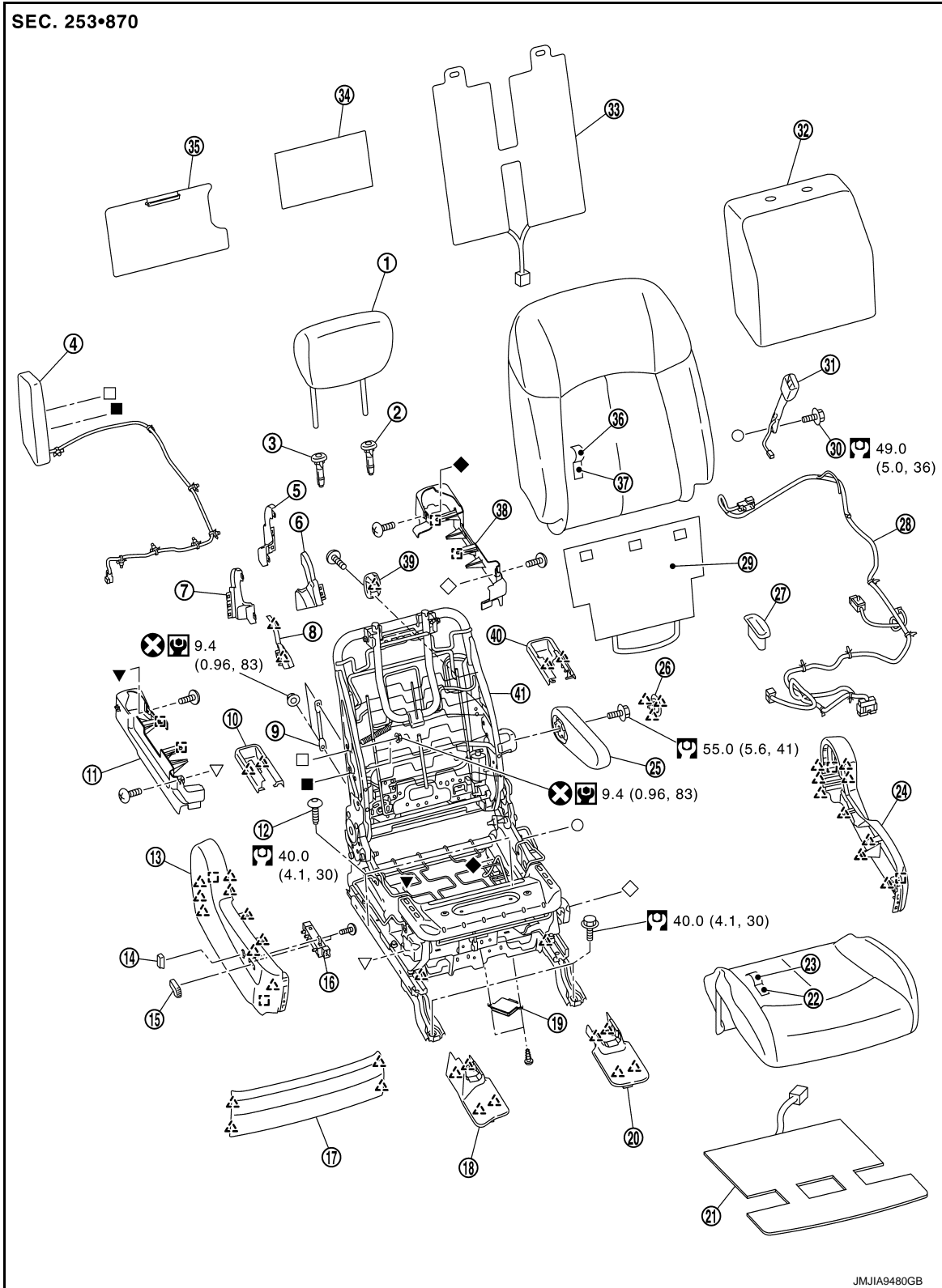

- |  |   |   |
|--|---|---|
| 1. Headrest                            | 2. Headrest holder (locked)             | 3. Headrest holder (free)               |
| 4. Side air bag module                 | 5. Reclining device inner cover (rear)  | 6. Reclining device inner cover (front) |
| 7. Reclining device outer cover (rear) | 8. Reclining device outer cover (front) | 9. Side air bag rod                     |
| 10. Seat slide rear outer cover        | 11. Lower outer finisher                | 12. TORX bolt                           |
| 13. Seat cushion outer finisher        | 14. Seat reclining switch knob          | 15. Seat slide & lifter switch knob     |
| 16. Seat switch assembly               | 17. Seat cushion finisher               | 18. Seat slide front outer cover        |

# FRONT SEAT (POWER SEAT)

## < REMOVAL AND INSTALLATION >

- |  |                                    |                                 |
|--|------------------------------------|---------------------------------|
| 19. Occupant detection system control unit | 20. Seat slide front inner cover   | 21. Seat cushion heater unit    |
| 22. Seat cushion pad                       | 23. Seat cushion trim              | 24. Seat cushion inner finisher |
| 25. Armrest assembly                       | 26. Armrest cap                    | 27. Seat belt buckle trim       |
| 28. Seat harness assembly                  | 29. Seatback lower carpet          | 30. Anchor bolt                 |
| 31. Seat belt buckle                       | 32. Seatback silencer              | 33. Seatback heater unit        |
| 34. Seatback felt                          | 35. Seatback board                 | 36. Seatback trim               |
| 37. Seatback pad                           | 38. Lower inner finisher           | 39. Seatback hook assembly      |
| 40. Seat slide rear inner cover            | 41. Seat frame & adjuster assembly |                                 |

 : Pawl

 : Metal clip

 : Always replace after every disassembly.

 : N·m (kg-m, ft-lb)

 : N·m (kg-m, in-lb)

 : Indicates that the part is connected at points with same symbol in actual vehicle.

## Removal and Installation

INFOID:0000000011325329

### REMOVAL

#### **WARNING:**

**Before servicing, turn ignition switch OFF, disconnect battery negative terminal and wait 3 minutes or more.**

#### **NOTE:**

When removing lower outer finisher, lower inner finisher, side air bag, and seat harness on driver side, operate seat slide & seat lifter switch and set seat cushion to the highest position in advance. This facilitates removal.

1. Remove headrest.
2. Operate seat slide & lifter switch and slide seat to the frontmost position.
3. Remove seat slide rear outer cover.
  - a. Disengage pawls on the rear side of seat slide rear outer cover.
  - b. Disengage pawls on the front side of seat slide rear outer cover.
  - c. Slide seat slide rear outer cover to the rear side to remove.

 : Pawl

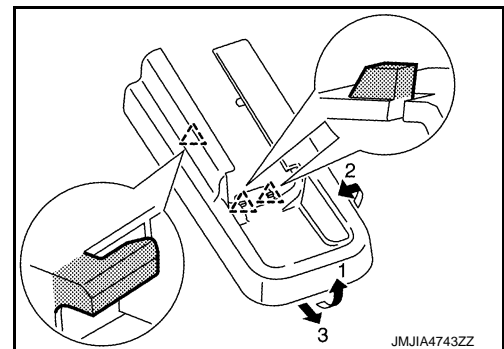

4. Remove seat slide rear inner cover.
  - a. Disengage pawls on the rear side of seat slide rear inner cover.
  - b. Disengage pawls on the front side of seat slide rear inner cover.
  - c. Slide seat slide rear inner cover to the rear side to remove.

 : Pawl

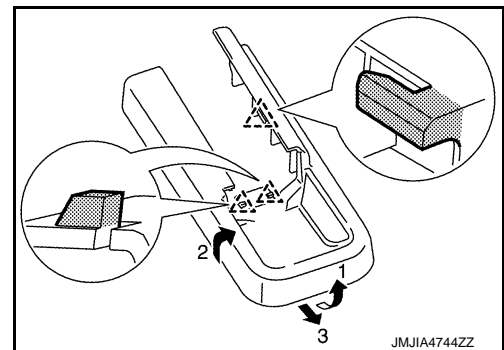

5. Remove rear outer mounting TORX bolt.

## FRONT SEAT (POWER SEAT)

### < REMOVAL AND INSTALLATION >

6. Remove rear inner mounting TORX bolt.
7. Operate seat slide & lifter switch and slide seat to the rearmost position.
8. Remove seat slide front outer cover.
  - a. Disengage pawls on the front side of seat slide front outer cover.
  - b. Disengage pawls on the rear side of seat slide front outer cover.
  - c. Slide seat slide front outer cover to the front side while lifting it upward to remove.

 : Pawl

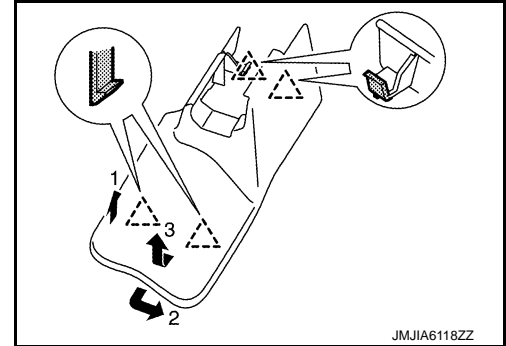

9. Remove seat slide front inner cover.
  - a. Disengage pawls on the front side of seat slide front inner cover.
  - b. Disengage pawls on the rear side of seat slide front inner cover.
  - c. Slide seat slide front inner cover to the front side while lifting it upward to remove.

 : Pawl

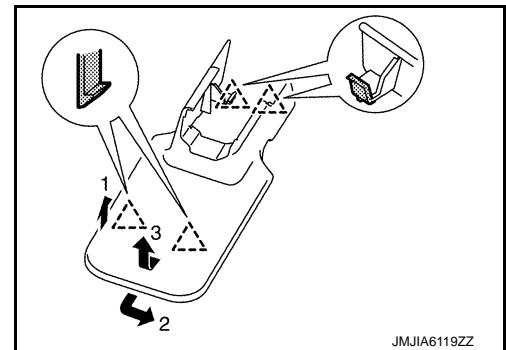

10. Remove front outer mounting bolt.
11. Remove front inner mounting bolt.
12. Operate seat reclining switch and set the seatback vertically.
13. Disconnect seat cushion lower harness connector, and then remove harness fixing clips.

#### **WARNING:**

**Never insert foreign materials, such as a screwdriver, into air bag module connector. (This is to prevent accidental activation caused by static electricity.)**

#### **CAUTION:**

**Before performing removal operation, check the installation position of harness connectors and harness fixing clamps.**

14. Remove seat from the vehicle.

#### **CAUTION:**

**When removing and installing, use shop cloths to protect parts from damage.**

### INSTALLATION

Note the following items, and install in the reverse order of removal.

#### **CAUTION:**

- When removing and installing, use shop cloths to protect parts from damage.
- Before tightening bolts, check that the carpet is not caught in bolt holes on mounting portion.
- Always fix the harness fixing clamp in position.
- When connecting the connector, be sure to raise lock, and then push lock into the connector to fix. Check that the lock is engaged securely after connecting the connector.



# FRONT SEAT (POWER SEAT)

## < REMOVAL AND INSTALLATION >

- When installing, tighten mounting bolts to the specified torque according to the numerical order as shown in the figure, starting from front inner mounting bolt.  
For the specified torque, refer to [SE-100. "Exploded View"](#).

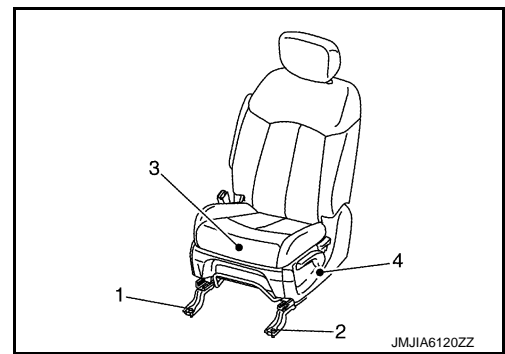

### NOTE:

After installing the front seat, perform additional service when removing battery negative terminal.

Refer to [ADP-46. "Description"](#).

## SEATBACK

### SEATBACK : Disassembly and Assembly

INFOID:000000011325330

#### DISASSEMBLY

1. Remove armrest assembly.
  - a. Disengage pawls and remove armrest cap.

 : Pawl

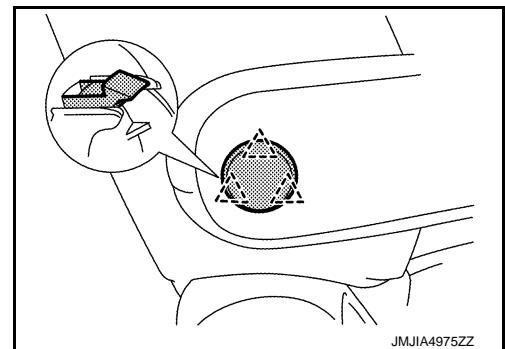

- b. Remove mounting bolt, and remove armrest assembly.
2. Remove the seatback retainer (A), and then open seatback fastener (B).
3. Roll up seatback trim, and then remove seatback retainer (C).

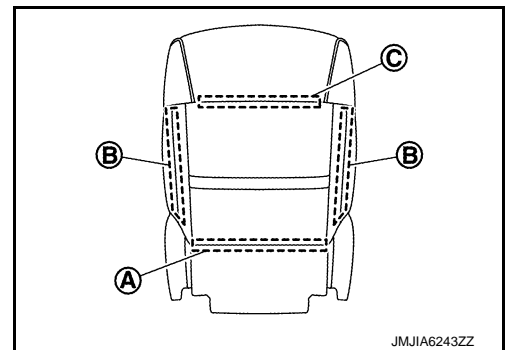

4. Remove side air bag module.
  - a. Remove seatback lower carpet from the seatback trim retainer.

## FRONT SEAT (POWER SEAT)

### < REMOVAL AND INSTALLATION >

- b. Remove seatback trim retainer (A) and (B).

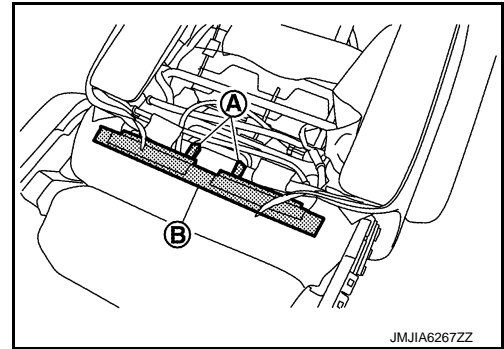

- c. Remove seat cushion lower side air bag module harness connector clip and side air bag module harness clip.  
d. Remove side air bag module harness clips from the seat frame & adjuster assembly.  
e. Pull out side air bag module harness (A) from the side or reclining device finisher.

 : Clip

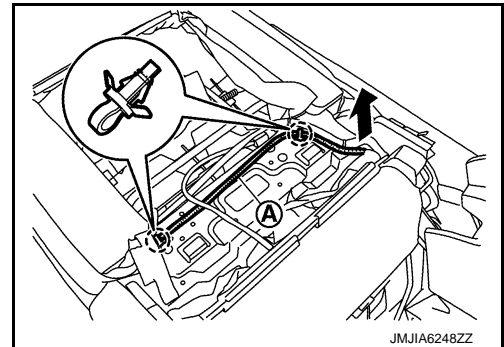

- f. Remove mounting nuts, and then remove side air bag rod from the seat frame & adjuster assembly.  
g. Pull up seatback pad (1) as shown in the figure and secure work space. Remove side air bag module (3) from the inner cloth (2).

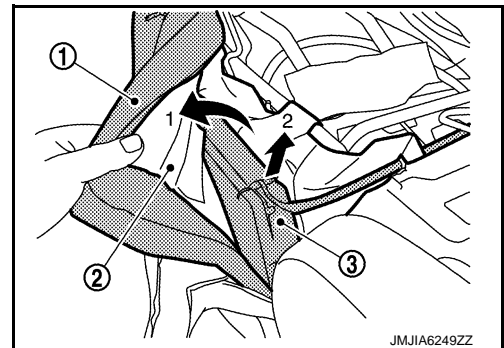

### CAUTION:

- Never damage seatback trim or inner cloth (reinforcement cloth).
- Check direction if side air bag module.
- Never disassemble and check inflator. Side air bag module must never be disassembled.
- To prevent damage to the parts, never impact the side air bag module.
- Replace the side air bag module if it is dropped or sustains an impact.

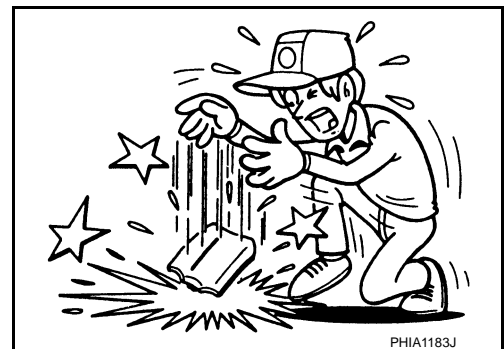

- To prevent accidental explosion, never expose the side air bag module to temperatures more than 90°C (194°F).
- Place air bag module as a unit with side air bag deployment surface facing upward (stud bolts facing downward). (This is to prevent accidental deployment.)

# FRONT SEAT (POWER SEAT)

## < REMOVAL AND INSTALLATION >

5. Remove seatback hook assembly.
  - a. Rotate seatback hook to the position where fixing screw (A) can be removed, and then remove screw.
  - b. Pull seatback hook assembly forward, disengage pawl, and then remove seatback hook assembly from the seatback.

 : Pawl

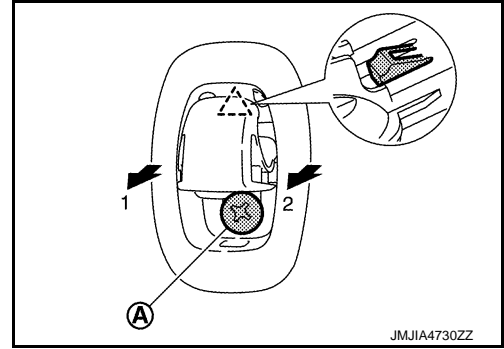

6. Disconnect seatback heater unit harness connector (A).

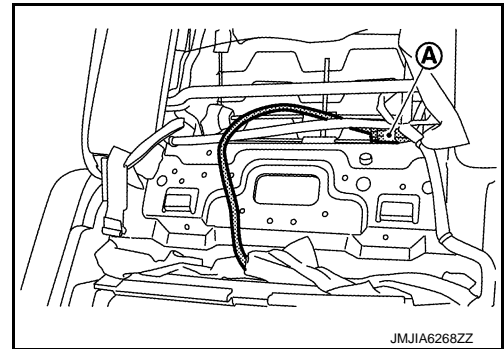

7. Remove the headrest holder from the seatback while pressing the pawls as shown by the arrows in the figure.

**CAUTION:**

**Before installing headrest holder check its orientation. (Front/rear and right/left)**

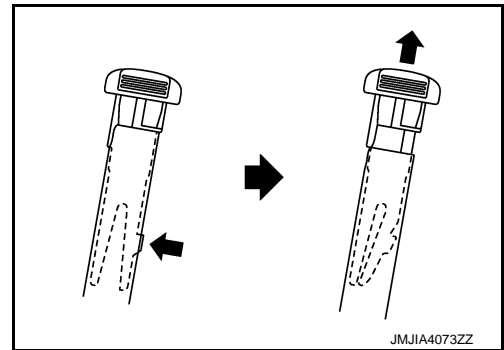

8. Remove seatback trim, seatback pad and seatback heater unit from seat frame & adjuster assembly.
9. Remove hog rings, and separate the seatback trim and seatback pad.

**CAUTION:**  
**Before performing separating operation, check the installation position of hog rings.**
10. Separate the seatback pad and seatback heater unit.
11. Remove seatback silencer from seat frame & adjuster assembly.

## ASSEMBLY

Note the following, and assemble in the reverse order of disassembly.

**CAUTION:**

- Check the following parts for lubrication. Apply grease if necessary.

A  
B  
C  
D  
E  
F  
G  
H  
I  
SE  
K  
L  
M  
N  
O  
P

# FRONT SEAT (POWER SEAT)

## < REMOVAL AND INSTALLATION >

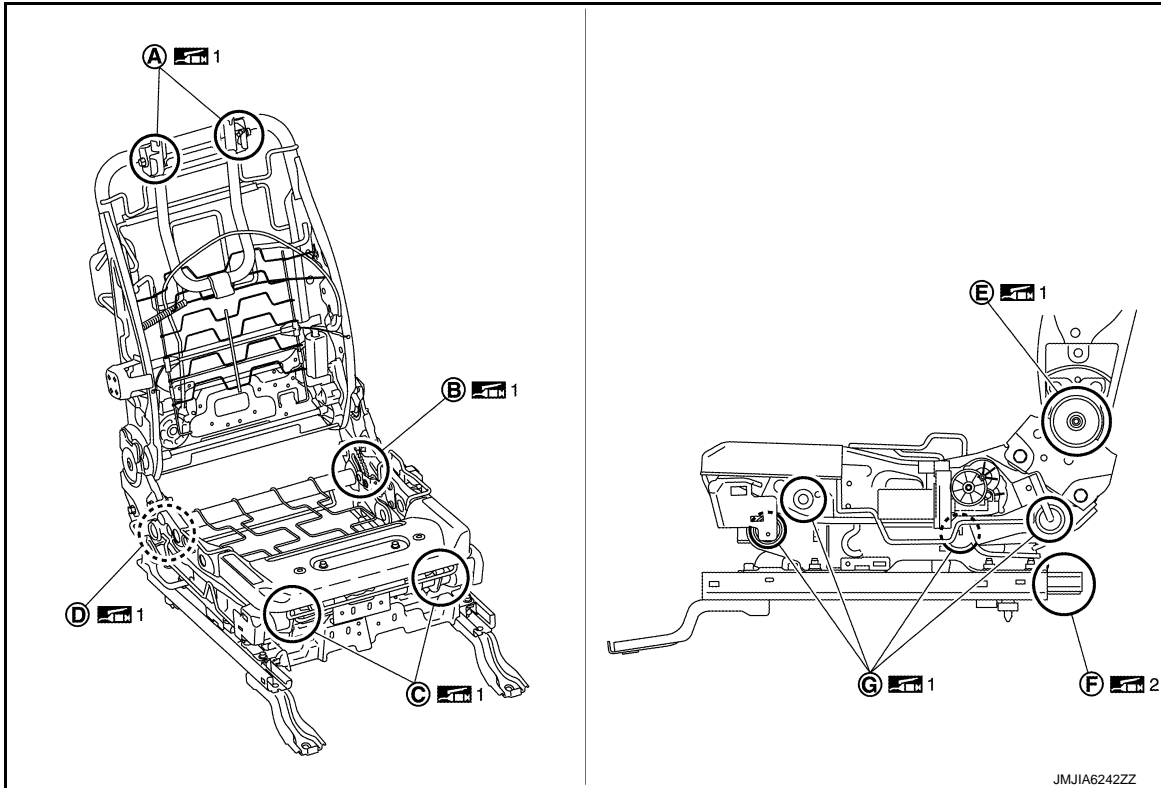

- A. Active headrest rotation engage SP bolt portion
- B. Sector gear sliding portion
- C. Front lifter link sliding portion
- D. Rear lifter link sliding portion
- E. Recliner base core sliding portion
- F. Slide rail sliding portion
- G. Seat lifter pipe (front and rear) crimp sliding portion

 : Heat-resistant and cold-resistant grease (Nippeco LLP or an equivalent)

 : Heat-resistant and cold-resistant grease (RHEOGEL or an equivalent)

- Check seatback pad and seatback trim for damage. Replace with new part if necessary.
- Install hog ring (A) to the specified position as shown in the figure.

B. hook and loop fastener

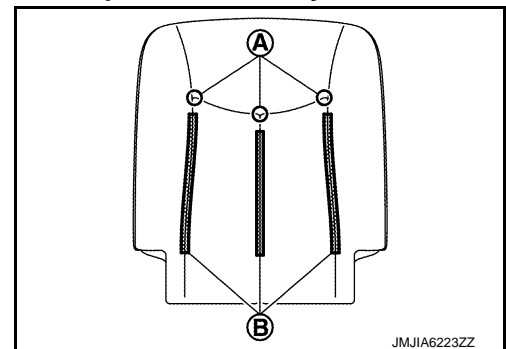

- If crimping using a hog ring is unsuccessful, using a new hog ring.
- Check that cutting slits on side air bag module cloth cover are not damaged. Replace side air bag module with a new one if necessary.
- Check that part number of the side air bag module is appropriate to seat specification.

## FRONT SEAT (POWER SEAT)

### < REMOVAL AND INSTALLATION >

- Check that side air bag module (1) and inner cloth (reinforcement cloth) (B) is in the position as shown in the figure.

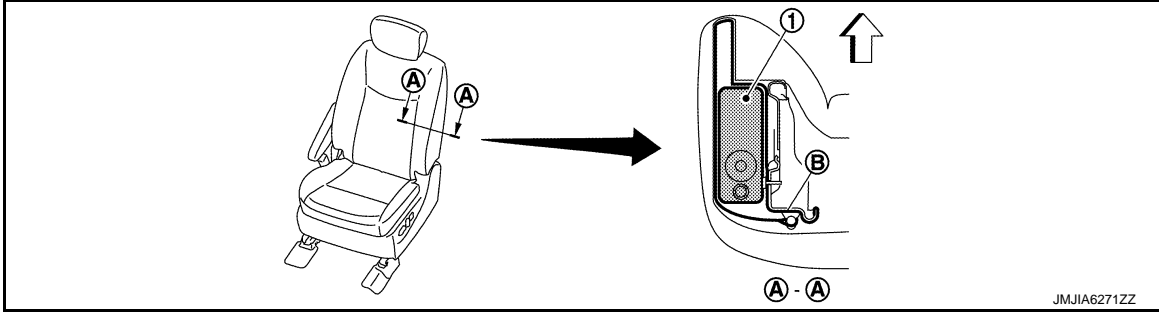

← : Vehicle front

- Check inner cloth (reinforcement cloth) for wrinkles and folding.
- Check that inner cloth (reinforcement cloth) is not pinched.
- Check that seatback trim and is fixed correctly.
- Never damage harness, connector, or clips of the side air bag module.
- Never damage seatback trim or inner cloth (reinforcement cloth).
- Check direction of side air bag module.
- Use new mounting nut when mounting the side air bag module. Tighten to the specified torque. For the specified torque, refer to [SE-100, "Exploded View"](#).
- Be careful not to leave any foreign materials (screwdriver or others) in seatback.
- Check that harness route and harness clip installation position are in the specified positions.
- When harness clip is damaged, mark the clip position and replace damaged clip with a new one in the original position.

### SEAT CUSHION

#### SEAT CUSHION : Disassembly and Assembly

INFOID:0000000011325331

#### DISASSEMBLY



##### Driver seat

1. Pull seat cushion finisher forward, disengage pawls, and then remove seat cushion finisher.

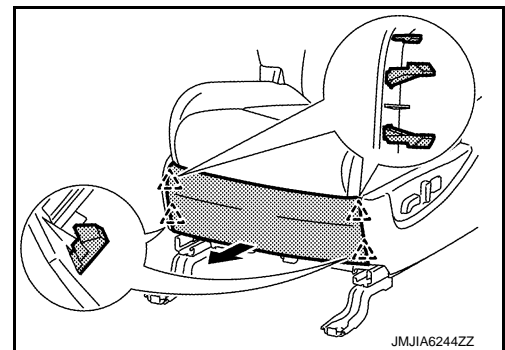
 : Pawl



2. Remove seat cushion outer finisher.
  - a. Pull seat cushion outer finisher forward, disengage pawls and metal clips, and then remove seat cushion outer finisher.

 : Pawl  
 : Metal clip

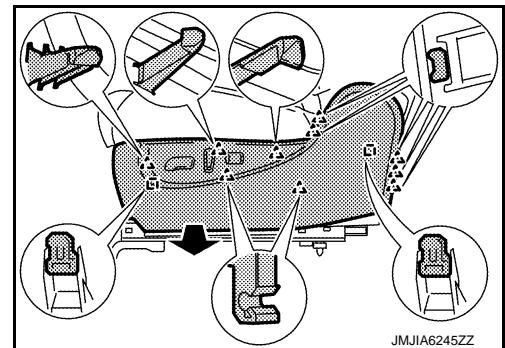

## FRONT SEAT (POWER SEAT)

### < REMOVAL AND INSTALLATION >

- b. Disconnect seat switch assembly harness connector and lumbar support switch assembly harness connector.
3. Remove seat switch assembly and lumbar support switch assembly from seat cushion outer finisher.
4. Pull seat cushion inner finisher toward seat front. Disengage pawls and metal clips. Slide seat cushion inner finisher upwards. Remove seat cushion inner finisher.

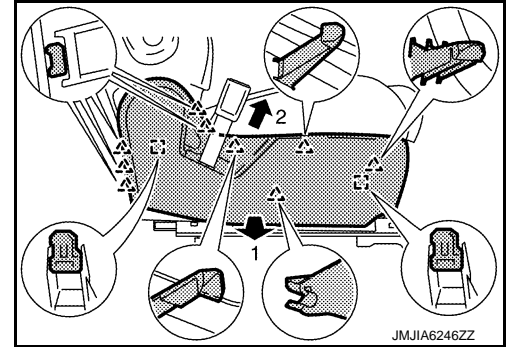
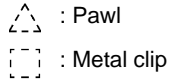

5. Remove seat cushion trim, seat cushion pad, and seat cushion heater unit from seat frame & adjuster assembly.
  - a. Disconnect seat cushion heater unit harness connector (A) installed in the lower portion of seat cushion.
  - b. Remove seatback lower carpet rubber band (1) installed in the lower portion of seat cushion.

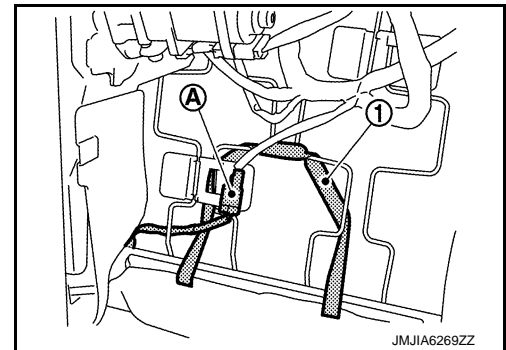

- c. Remove seat cushion trim retainer installed on seat frame & adjuster assembly.
- d. Remove seat cushion trim, seat cushion pad, and seat cushion heater unit from seat frame & adjuster assembly.
6. Remove hog rings, and separate the seat cushion trim and seat cushion pad.  
**CAUTION:**  
**Before performing separating operation, check the installation position of hog rings.**
7. Separate the seat cushion pad and seat cushion heater unit.
8. Remove seatback trim and seatback pad from seat frame & adjuster assembly.  
Refer to [SE-105, "SEATBACK : Disassembly and Assembly"](#).
9. Remove reclining device cover.
  - Disengage pawls and remove reclining device outer cover (front and rear).
  - Disengage pawls and remove reclining device inner cover (front and rear).
10. Remove following parts from seat frame & adjuster assembly.
  - Remove lower outer finisher.
  - Remove lower inner finisher.
  - Remove seat belt buckle trim.
  - Remove seat belt buckle. Refer to [SB-9, "SEAT BELT BUCKLE : Removal and Installation"](#).
  - Remove seatback board.
  - Remove seatback felt.
  - Remove seat harness from seat frame & adjuster assembly.

Passenger seat

# FRONT SEAT (POWER SEAT)



## < REMOVAL AND INSTALLATION >

1. Pull seat cushion finisher forward, disengage pawls, and then remove seat cushion finisher.

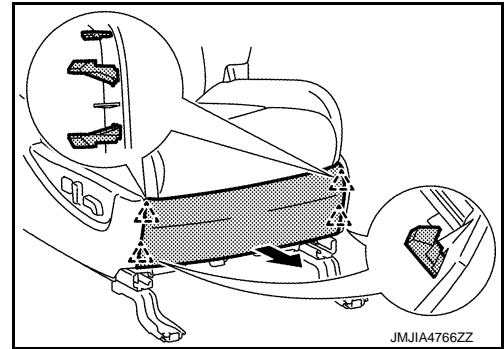
 : Pawl



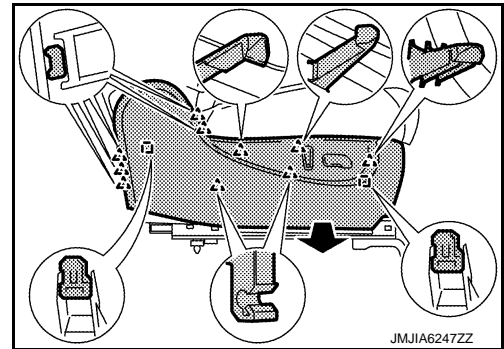

2. Remove seat cushion outer finisher.
  - a. Pull seat cushion outer finisher forward, disengage pawls and metal clips, and then remove seat cushion outer finisher.

 : Pawl  
 : Metal clip



- b. Disconnect seat switch assembly harness connector.
3. Remove seat switch assembly from seat cushion outer finisher.
4. Pull seat cushion inner finisher toward seat front. Disengage pawls and metal clips. Slide seat cushion inner finisher upwards. Remove seat cushion inner finisher.

 : Pawl  
 : Metal clip

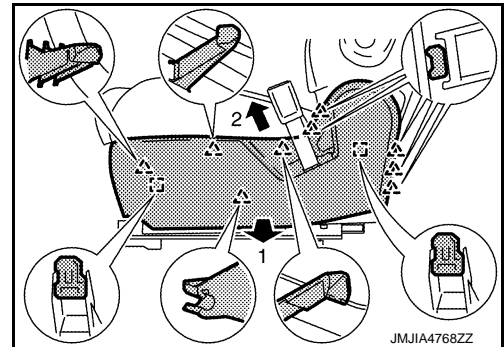

5. Remove seat cushion trim, seat cushion pad, and seat cushion heater unit from seat frame & adjuster assembly.
  - a. Disconnect seat cushion heater unit harness connector (A) installed in the lower portion of seat cushion.
  - b. Remove seatback lower carpet rubber band (1) installed in the lower portion of seat cushion.

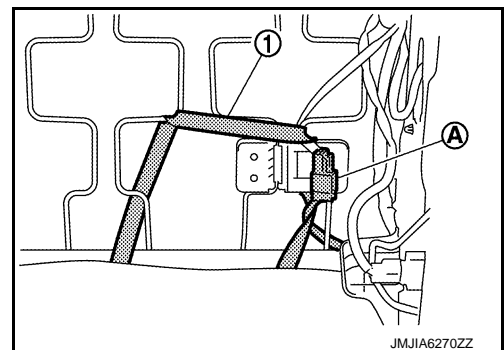

- c. Remove seat cushion trim retainer installed on seat frame & adjuster assembly.
- d. Remove seat cushion trim, seat cushion pad, and seat cushion heater unit from seat frame & adjuster assembly.
6. Remove hog rings, and separate the seat cushion trim and seat cushion pad.

**CAUTION:**

A  
B  
C  
D  
E  
F  
G  
H  
I  
SE  
K  
L  
M  
N  
O  
P

## FRONT SEAT (POWER SEAT)

### < REMOVAL AND INSTALLATION >

**Before performing separating operation, check the installation position of hog rings.**

7. Separate the seat cushion pad and seat cushion heater unit.
8. Remove seatback trim and seatback pad from seat frame & adjuster assembly.  
Refer to [SE-105. "SEATBACK : Disassembly and Assembly"](#).
9. Remove reclining device cover.
  - Disengage pawls and remove reclining device outer cover (front and rear).
  - Disengage pawls and remove reclining device inner cover (front and rear).
10. Remove following parts from seat frame & adjuster assembly.
  - Remove lower outer finisher.
  - Remove lower inner finisher.
  - Remove seat belt buckle trim.
  - Remove seat belt buckle. Refer to [SB-9. "SEAT BELT BUCKLE : Removal and Installation"](#).
  - Remove seatback board.
  - Remove seatback felt.
  - Remove seat harness from seat frame & adjuster assembly.
  - Remove occupant detection system control unit. Refer to [SR-32. "Removal and Installation"](#).

### ASSEMBLY

Note the following, and assemble in the reverse order of disassembly.

#### **CAUTION:**

- Check seat cushion trim and seat cushion pad for damage. Replace with new part if necessary.
- Install seat cushion front hog rings (A) and seat cushion back hog rings (B) to the specified positions.

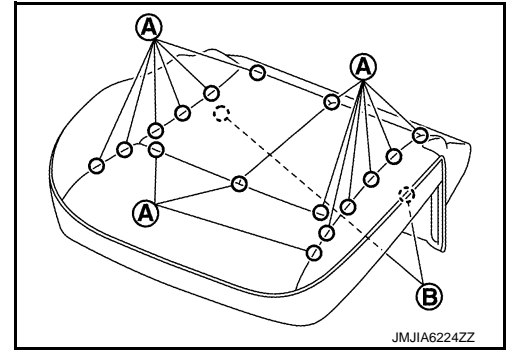

- Check the following parts for lubrication. Apply grease if necessary.



# FRONT SEAT (POWER SEAT)

## < REMOVAL AND INSTALLATION >

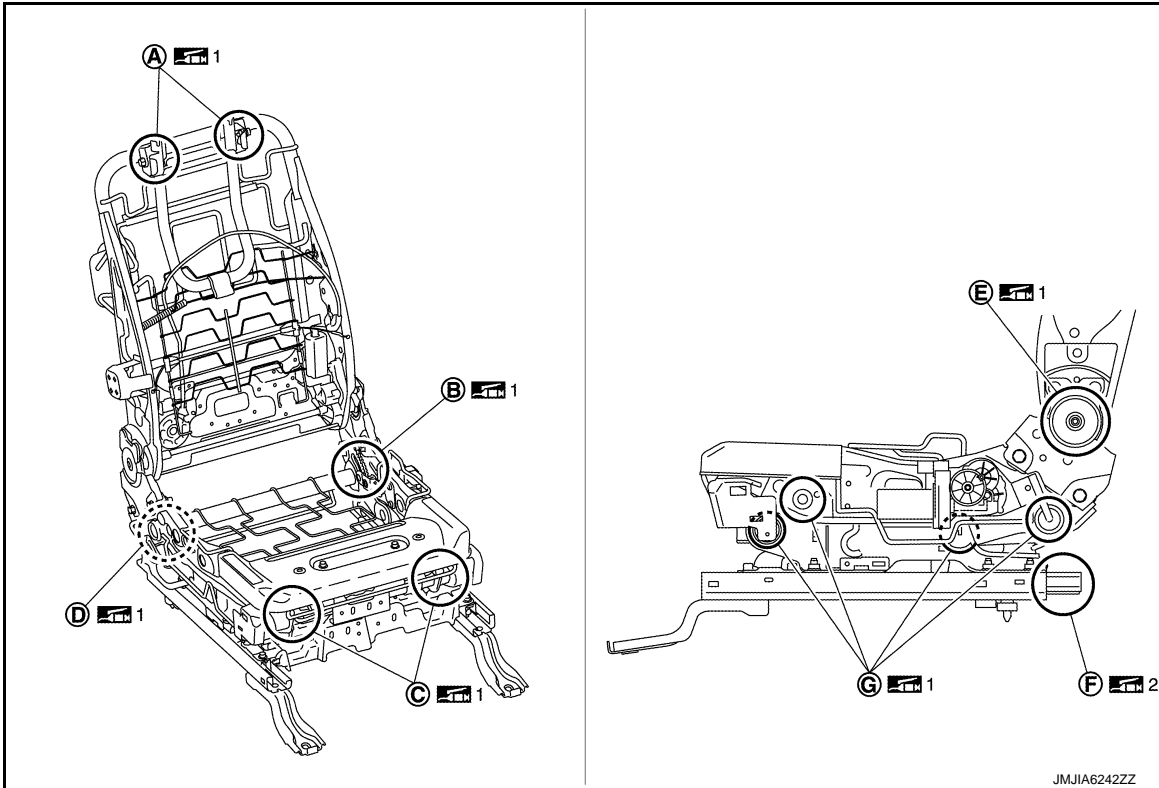

A  
B  
C  
D  
E  
F  
G  
H

- A. Active headrest rotation engage SP bolt portion
- B. Sector gear sliding portion
- C. Front lifter link sliding portion
- D. Rear lifter link sliding portion
- E. Recliner base core sliding portion
- F. Slide rail sliding portion
- G. Seat lifter pipe (front and rear) crimp sliding portion

I

SE

 : Heat-resistant and cold-resistant grease (Nippeco LLP or an equivalent)

 : Heat-resistant and cold-resistant grease (RHEOGEL or an equivalent)

- If crimping using a hog ring is unsuccessful, secure using a new hog ring.
- Check that harness route and harness clip installation position are in the specified positions.
- When harness clip is damaged, mark the clip position and replace damaged clip with a new one in the original position.
- Tighten seat belt buckle anchor bolt to the specified torque.  
For the specified torque, refer to [SE-86. "Exploded View"](#).

K

L

M

N

O

P

# SECOND SEAT

< REMOVAL AND INSTALLATION >

## SECOND SEAT

Exploded View

INFOID:000000011325332

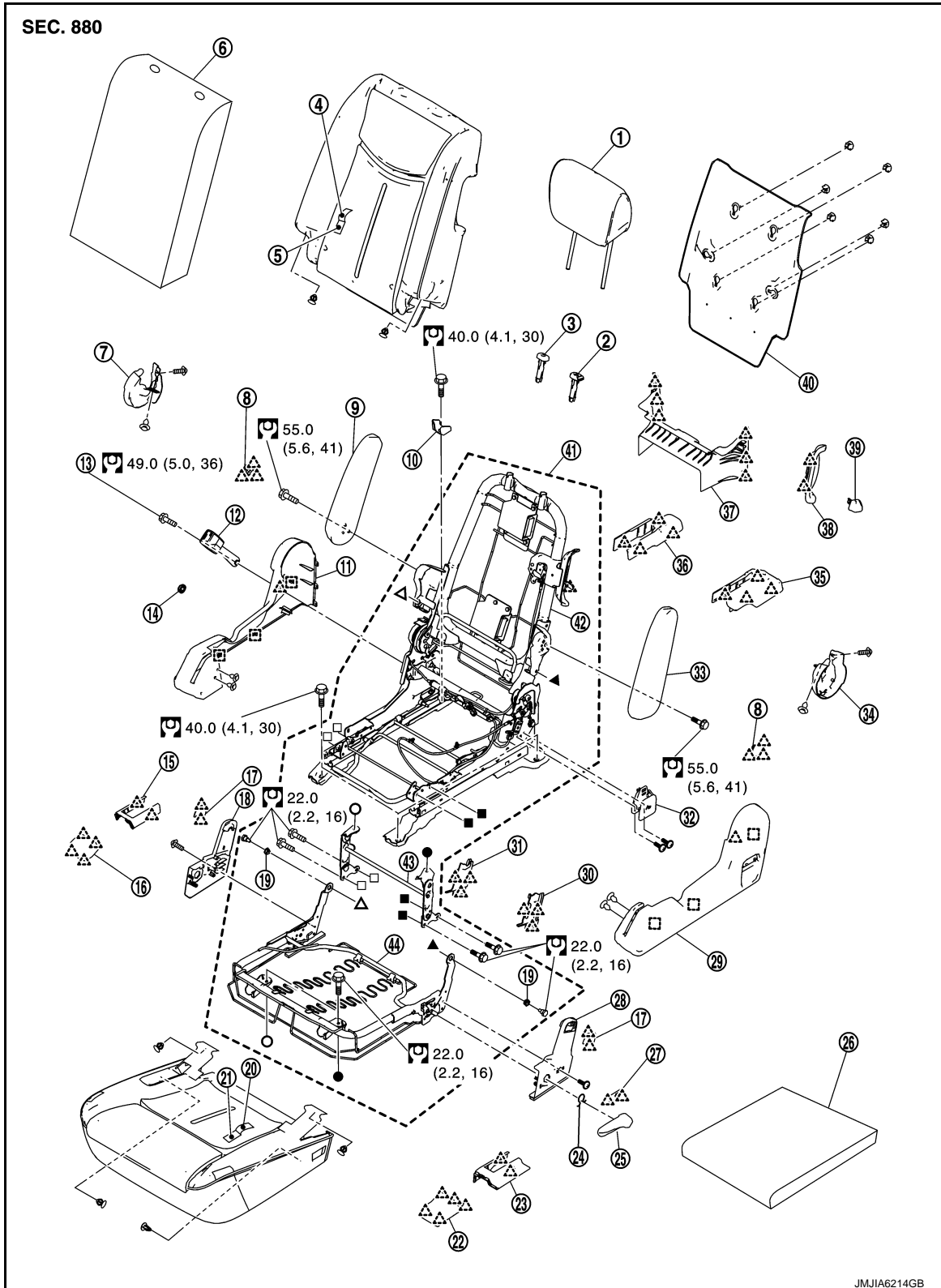

JMJIA6214GB

- |                                 |                             |                           |
|---------------------------------|-----------------------------|---------------------------|
| 1. Headrest                     | 2. Headrest holder (locked) | 3. Headrest holder (free) |
| 4. Seatback trim                | 5. Seatback pad             | 6. Seatback silencer      |
| 7. Reclining device inner cover | 8. Armrest cap              | 9. Inner armrest assembly |

# SECOND SEAT

## < REMOVAL AND INSTALLATION >

- |  |                                       |                                       |
|--|---------------------------------------|---------------------------------------|
| 10. Seat slide bracket                 | 11. Seat cushion inner finisher       | 12. Seat belt buckle                  |
| 13. Anchor bolt                        | 14. Anchor bolt cap                   | 15. Seat front inner leg cover (rear) |
| 16. Seat front inner leg cover (front) | 17. Seat hinge finisher cap           | 18. Seat hinge outer finisher RH      |
| 19. Bush                               | 20. Seat cushion trim                 | 21. Seat cushion pad                  |
| 22. Seat front outer leg cover (front) | 23. Seat front outer leg cover (rear) | 24. Snap ring                         |
| 25. Seat reclining lever knob          | 26. Seat cushion silencer             | 27. Seat hinge finisher patch         |
| 28. Seat hinge outer finisher LH       | 29. Seat cushion outer finisher       | 30. Seat hinge inner finisher LH      |
| 31. Seat hinge inner finisher RH       | 32. Seat folding lever assembly       | 33. Outer armrest assembly            |
| 34. Reclining device outer cover       | 35. Seat rear outer leg cover         | 36. Seat rear inner leg cover         |
| 37. Seat cushion rear center finisher  | 38. Walk-in lever escutcheon          | 39. Walk-in lever knob                |
| 40. Seatback board                     | 41. Seat frame & adjuster assembly    | 42. Seat frame assembly               |
| 43. Seat link assembly                 | 44. Seat cushion frame                |                                       |

 : Pawl

 : Metal clip

 : N·m (kg-m, ft-lb)

■, ▲, ■, ○, △, □ : Indicates that the part is connected at points with same symbol in actual vehicle.

## Removal and Installation

INFOID:000000011325333

### REMOVAL

1. Remove headrest.
2. Remove rear kicking plate. Refer to [INT-22. "KICKING PLATE : Removal and Installation"](#).
3. Slide seat to the frontmost position.
4. Remove seat rear outer leg cover.
  - a. Pull up the rear edge of the seat rear outer leg cover to release the pawls.
  - b. Pull seat rear outer leg cover in direction indicated by the arrow as shown in the figure. Disengage pawls on the rear side.

 : Pawl

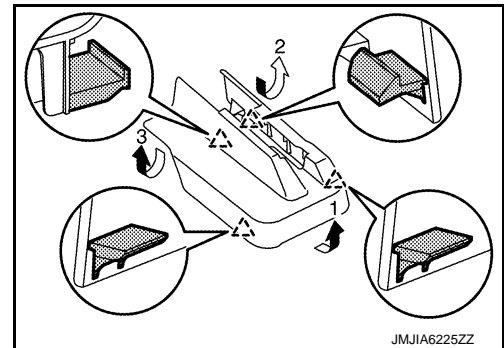

5. Remove seat rear inner leg cover.
  - a. Pull up the rear edge of the seat rear inner leg cover to release the pawls.
  - b. Pull seat rear inner leg cover in direction indicated by the arrow as shown in the figure. Disengage pawls on the rear side.

 : Pawl

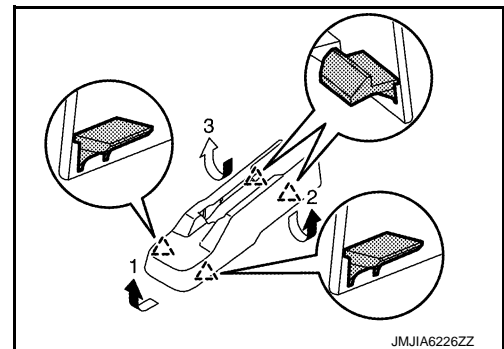

6. Remove rear outer mounting bolt.
7. Remove rear inner mounting bolt and seat slide bracket.
8. Slide seat to the rearmost position.
9. Remove seat front outer leg cover (front).

## SECOND SEAT

### < REMOVAL AND INSTALLATION >

- a. Pull up the front edge of the seat front outer leg (front) cover to release the pawls.
- b. Pull seat front outer leg cover (front) upwards. Disengage pawls on the rear side.

 : Pawl

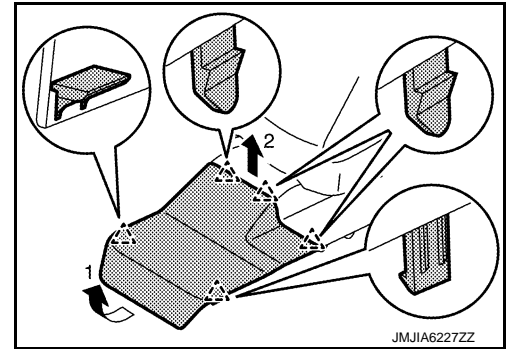

10. Remove seat front inner leg cover (front).
- a. Pull up the front edge of the seat front inner leg (front) cover to release the pawls.
- b. Pull seat front inner leg cover (front) upwards. Disengage pawls on the rear side.

 : Pawl

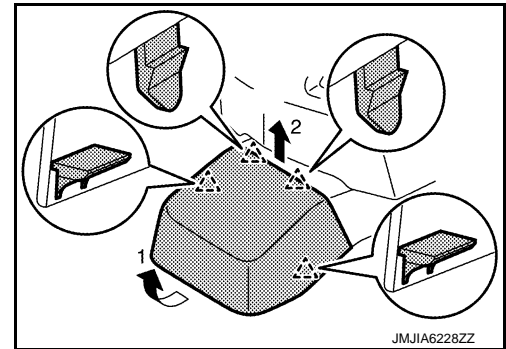

11. Remove front outer mounting bolt.
12. Remove front inner mounting bolt.
13. Remove seat from the vehicle.

#### **CAUTION:**

**When removing and installing, use shop cloths to protect parts from damage.**

### INSTALLATION

Note the following items, and install in the reverse order of removal.

#### **CAUTION:**

- When removing and installing, use shop cloths to protect parts from damage.
- When installing, tighten mounting bolts according to the numerical order as shown in the figure, starting from front inner mounting bolt.

For the specified torque, refer to [SE-114. "Exploded View"](#).

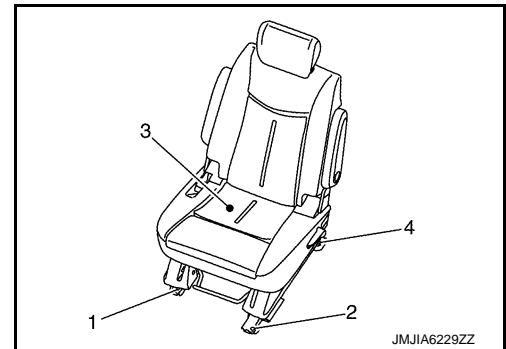

## SEATBACK

### SEATBACK : Disassembly and Assembly

INFOID:000000011325334

#### DISASSEMBLY

1. Remove walk-in lever escutcheon.

## SECOND SEAT

### < REMOVAL AND INSTALLATION >

- a. Pull down walk-in lever knob, disengage pawl using a screwdriver, and then slide walk-in lever knob to remove.

 : Pawl

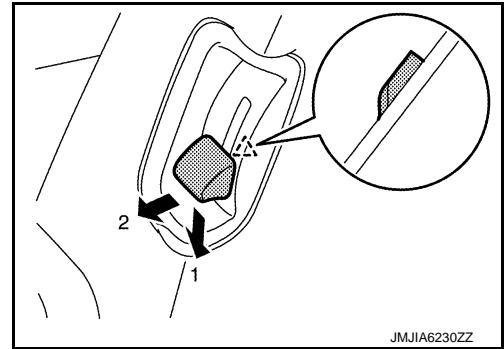

- b. Pull walk-in lever escutcheon forward, disengage pawls, and then remove walk-in lever escutcheon.

 : Pawl

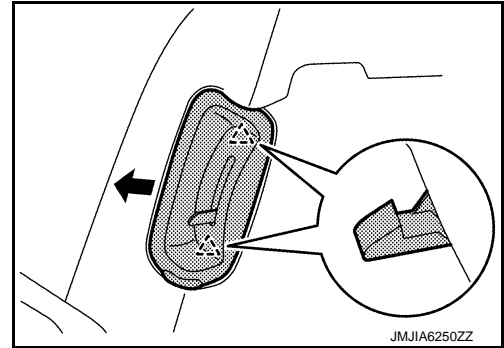

2. Remove inner armrest assembly and outer armrest.

- a. Disengage pawls and remove armrest cap.

 : Pawl

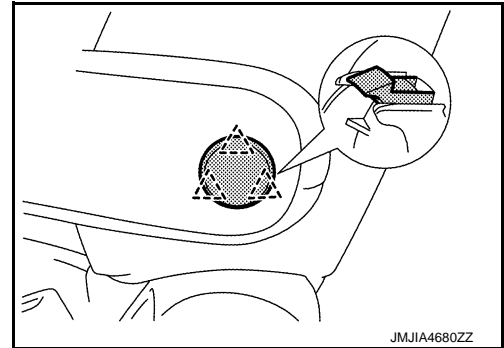

- b. Remove mounting bolt, and then remove inner armrest assembly and outer armrest assembly.

3. Remove seatback board from the seat frame & adjuster assembly.

- a. Operate seat reclining lever and fold seatback forward.
- b. Remove seatback trim hook and loop fastener (A).
- c. Remove seatback retainer (B), and then open seatback fastener (C).

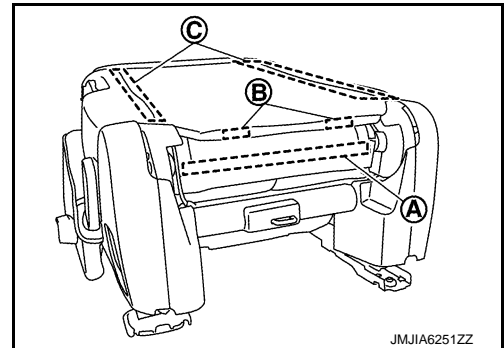

- d. Remove rubber band installed on seatback board.

A  
B  
C  
D  
E  
F  
G  
H  
I  
SE  
K  
L  
M  
N  
O  
P

## SECOND SEAT

### < REMOVAL AND INSTALLATION >

- e. Slide and align the clips (B) to the holes on the seatback as shown in the figure, and then remove the seatback board (A).

**CAUTION:**

**Always slide clips before removing seatback board. Clips may be damaged if seatback board is removed without sliding the clips.**

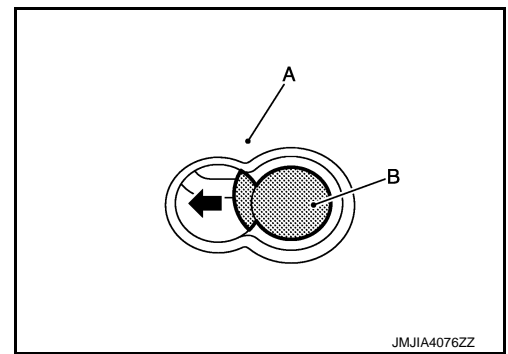

- f. Remove seatback board fixing clips from seatback frame assembly.

4. Set the seatback vertically.

5. Use pincers, etc., to press up pawls as shown by the arrows in the figure, and remove headrest holder from seatback.

**CAUTION:**

**Before installing headrest holder check its orientation. (front/rear and right/left)**

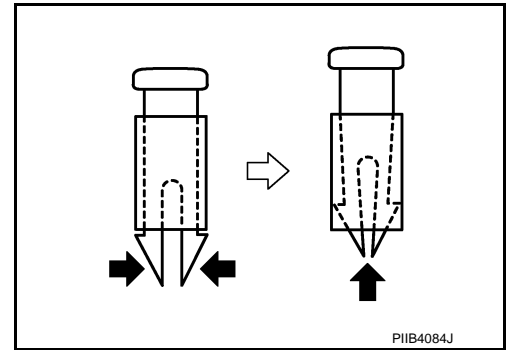

6. Remove seatback trim and seatback pad from seat frame & adjuster assembly.

- a. Remove retainer (A) installed on seat frame & adjuster assembly.

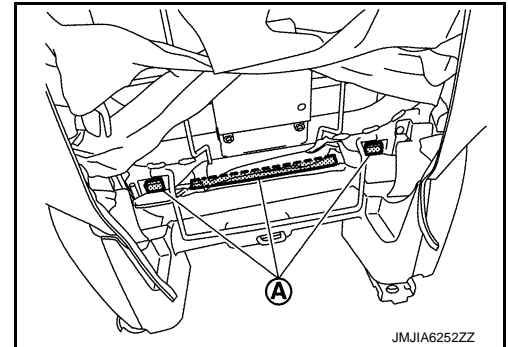

- b. Remove seat cushion trim fixing clips (A) installed on seatback trim.

○ : Clip

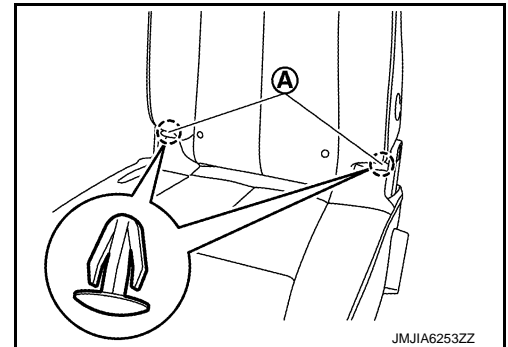

## SECOND SEAT

### < REMOVAL AND INSTALLATION >

- c. Disengage pawls and remove seat hinge finisher caps. (Inner side and outer side.)

 : Pawl

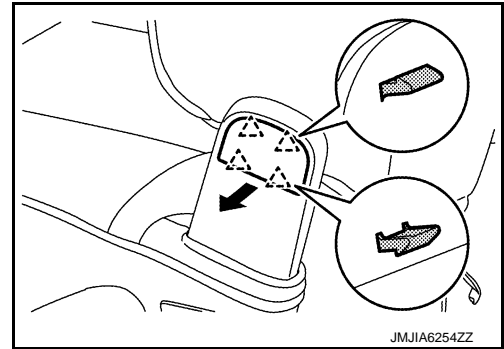

- d. Remove seat cushion frame assembly mounting bolts. Remove seat cushion assembly from seat frame assembly.  
e. Remove seatback trim fixing clips (A).

 : Clip

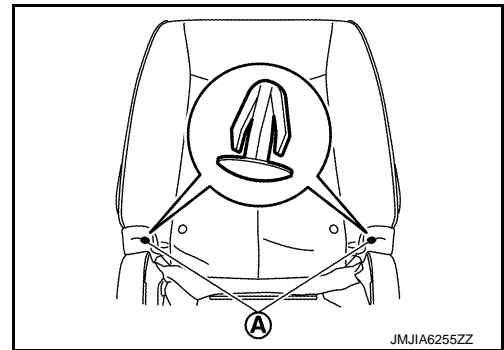

- f. Remove seatback trim and seatback pad from seat frame assembly.  
7. Remove hog rings, and separate the seatback trim and seatback pad.  
**CAUTION:**  
**Before performing separating operation, check the installation position of hog rings.**  
8. Remove fixing clip and screw, and then remove reclining device inner cover from seat frame assembly.  
9. Remove fixing clip and screw, and then remove reclining device outer cover from seat frame assembly.

### INSTALLATION

Note the following, and assembly in the reverse order of disassembly.

#### **CAUTION:**

- Check seatback trim and seatback pad for damage. Replace with new part if necessary.
- Install hog ring (A) to the specified position as shown in the figure.

B. hook and loop fastener

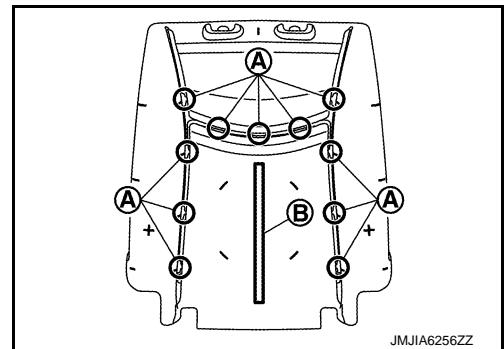

- If crimping using a hog ring is unsuccessful, secure using a new hog ring.

### SEAT CUSHION

#### SEAT CUSHION : Disassembly and Assembly

#### DISASSEMBLY

INFOID:000000011325335

## SECOND SEAT

### < REMOVAL AND INSTALLATION >

1. Remove snap ring (1) using a hook & pick tool, and then remove seat reclining device lever knob (2).

**NOTE:**

Remove snap ring while pressing seat cushion trim to the inner side of the seat. Snap ring can be easily removed.

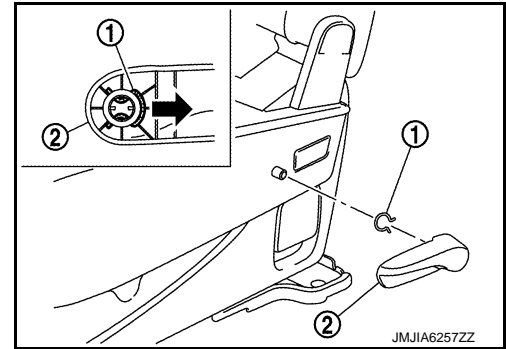

2. Disengage pawls and remove seat hinge finisher patch from seat cushion trim.

 : Pawl

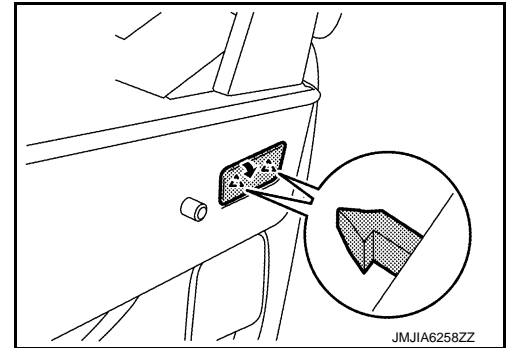

3. Remove seat cushion trim and seat cushion pad from seat cushion frame assembly.

- a. Remove seat cushion trim fixing clips (A) installed on seat back trim.

 : Clip

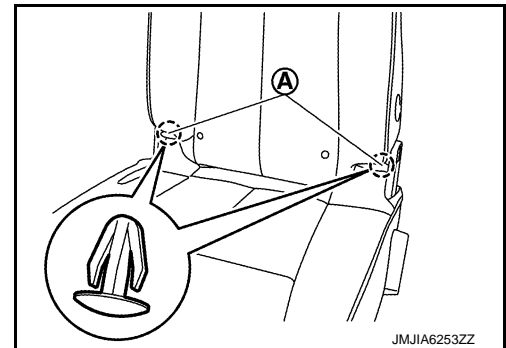

- b. Remove seat cushion trim retainer from seat cushion frame assembly.
  - c. Remove seat cushion trim J hook from seat cushion frame assembly.
  - d. Remove seat cushion trim hook and loop fastener.
  - e. Remove seat cushion trim fixing clips installed on seat frame assembly.
  - f. Remove seat cushion trim and seat cushion pad from seat cushion frame assembly.
4. Remove hog rings, and separate the seatback trim and seatback pad.

**CAUTION:**

**Before performing separating operation, check the installation position of hog rings.**

5. Remove seat cushion silencer from seat cushion frame assembly.
6. Remove seat hinge outer finisher (LH and RH).



## SECOND SEAT

### < REMOVAL AND INSTALLATION >

- a. Disengage pawls and remove seat hinge finisher cap. (Inner side and outer side.)

 : Pawl

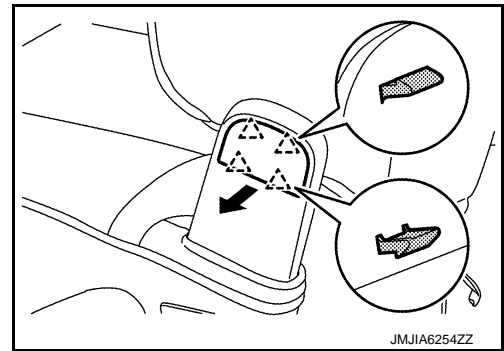

- b. Remove seat cushion frame assembly rear side mounting bolt, and then remove seat cushion assembly from seat frame assembly.  
 c. Remove seat hinge outer finisher (LH and RH) fixing screws.  
 d. Remove seat hinge outer finisher (LH and RH).  
 7. Remove seat hinge inner finisher (LH and RH).  
 8. Remove seat cushion frame assembly from seat frame assembly.

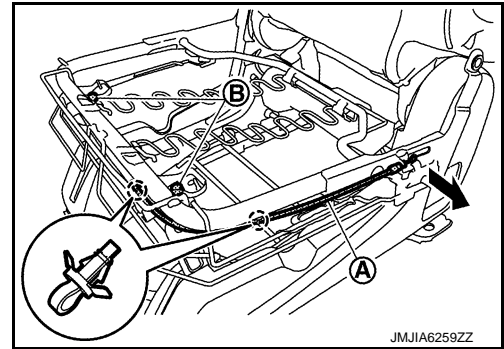

- a. Remove cable (A) from seat cushion frame assembly.  
 b. Remove cable fixing clips.  
 c. Remove seat cushion frame assembly front side mounting bolt (B) and then remove seat cushion frame assembly.

 : Clip



9. Remove seat cushion outer finisher.

- a. Remove fixing clips (A).  
 b. Pull seat cushion outer finisher in direction indicated by the arrow. Disengage pawls and metal clips. Remove seat cushion outer finisher.

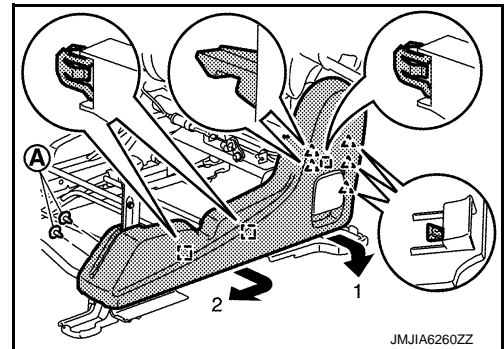

 : Pawl  
 : Metal clip



10. Remove seat front outer leg cover (rear).

11. Remove seat cushion inner finisher.

- a. Remove seat belt buckle. Refer to [SB-14, "SEAT BELT BUCKLE : Removal and Installation"](#).  
 b. Remove fixing clips (A).  
 c. Pull seat cushion inner finisher in direction indicated by the arrow. Disengage pawls and metal clips. Remove seat cushion inner finisher.

 : Pawl  
 : Metal clip

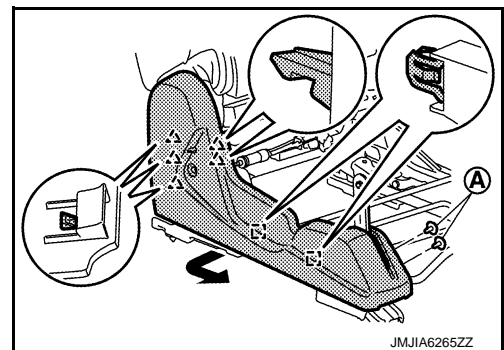

A  
B  
C  
D  
E  
F  
G  
H  
I

SE

K  
L  
M

N  
O  
P

## SECOND SEAT

### < REMOVAL AND INSTALLATION >

12. Remove seat front inner leg cover (rear).
13. Remove seat cushion rear center finisher.
14. Remove mounting bolts, and then remove seat link assembly.

### ASSEMBLY

Note the following, and assemble in the reverse order of disassembly.

#### CAUTION:

- Check seat cushion trim and seat cushion pad for damage. Replace with new part if necessary.
- Install hog ring (A) to the specified position as shown in the figure.

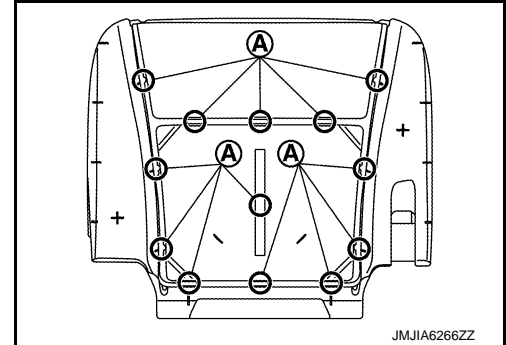

# THIRD SEAT

< REMOVAL AND INSTALLATION >

## THIRD SEAT

Exploded View

INFOID:000000011325336

RH SIDE SEAT

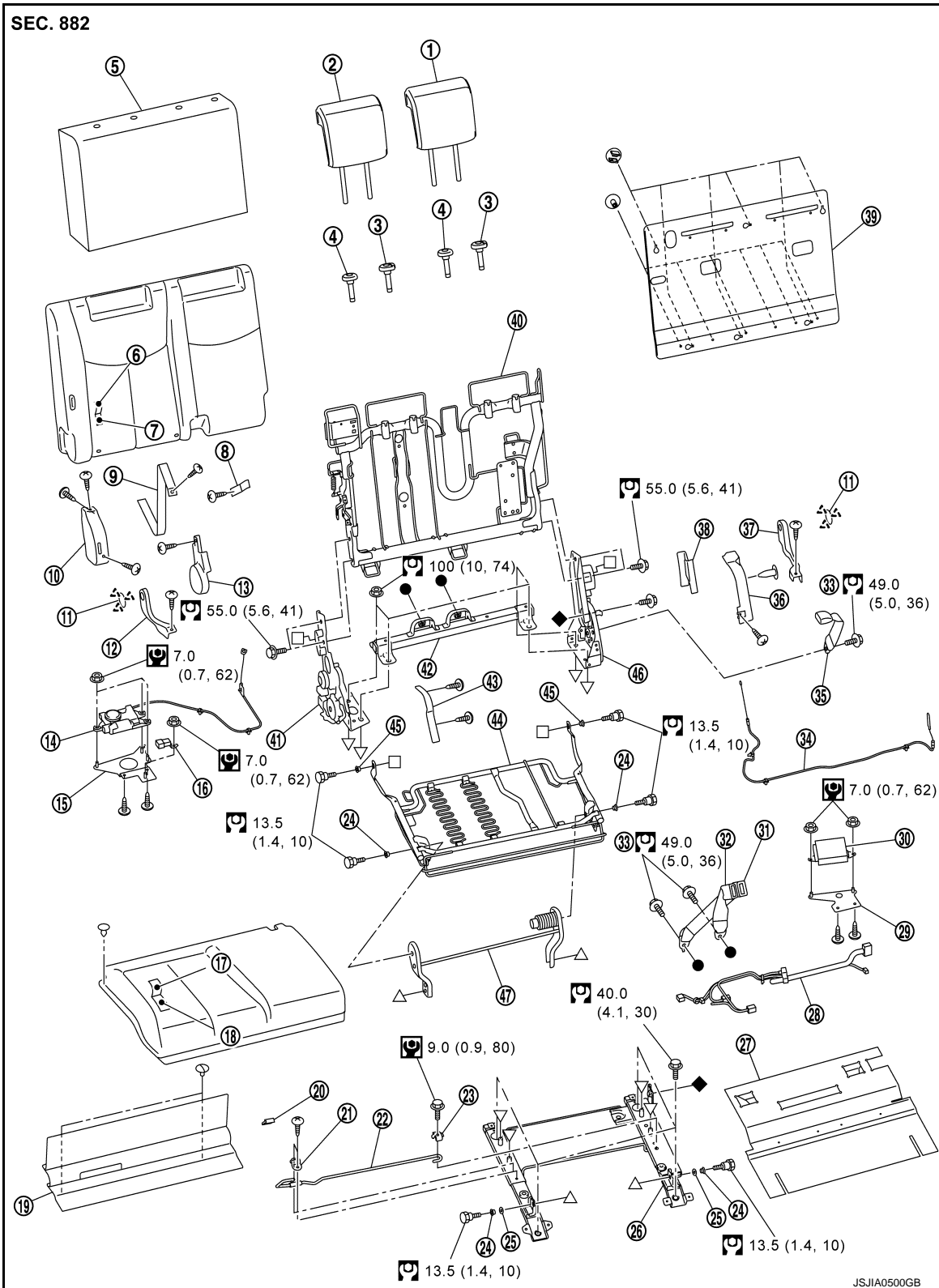

A  
B  
C  
D  
E  
F  
G  
H  
I  
SE  
K  
L  
M  
N  
O  
P

## THIRD SEAT

### < REMOVAL AND INSTALLATION >

---

- |                                    |                                    |                                    |
|------------------------------------|------------------------------------|------------------------------------|
| 1. Center headrest                 | 2. Headrest RH                     | 3. Headrest holder (locked)        |
| 4. Headrest holder (free)          | 5. Seatback silencer               | 6. Seatback trim                   |
| 7. Seatback pad                    | 8. Seatback strap (front)          | 9. Seatback strap (rear)           |
| 10. Strap link cover               | 11. Seat cushion hinge cap         | 12. Seat cushion outer hinge cover |
| 13. Seat hinge arm cover           | 14. Seatback lock actuator         | 15. Actuator bracket               |
| 16. Seatback lock relay            | 17. Seat cushion trim              | 18. Seat cushion pad               |
| 19. Seat cushion carpet            | 20. Torsion bar silencer           | 21. Seat torsion bar outer bracket |
| 22. Seat torsion bar               | 23. Seat torsion bar inner bracket | 24. Bush A                         |
| 25. Washer                         | 26. Seat adjuster assembly         | 27. Seat adjuster lower carpet     |
| 28. Seat harness assembly          | 29. Control unit bracket           | 30. Seat control unit              |
| 31. Center seat belt buckle        | 32. RH seat belt buckle            | 33. Anchor bolt                    |
| 34. Reclining cable                | 35. Connector buckle               | 36. Reclining device cover         |
| 37. Seat cushion inner hinge cover | 38. Reclining arm cover            | 39. Seatback board                 |
| 40. Seatback frame                 | 41. Seat hinge assembly            | 42. Reinforcement pipe assembly    |
| 43. Seat hinge cover               | 44. Seat cushion frame assembly    | 45. Bush B                         |
| 46. Reclining device assembly      | 47. Seat link assembly             |                                    |



: Pawl



: N·m (kg-m, ft-lb)



: N·m (kg-m, in-lb)

●, ◆, △, □, ▽ : Indicates that the part is connected at points with same symbol in actual vehicle.

### LH SIDE SEAT

# THIRD SEAT

< REMOVAL AND INSTALLATION >

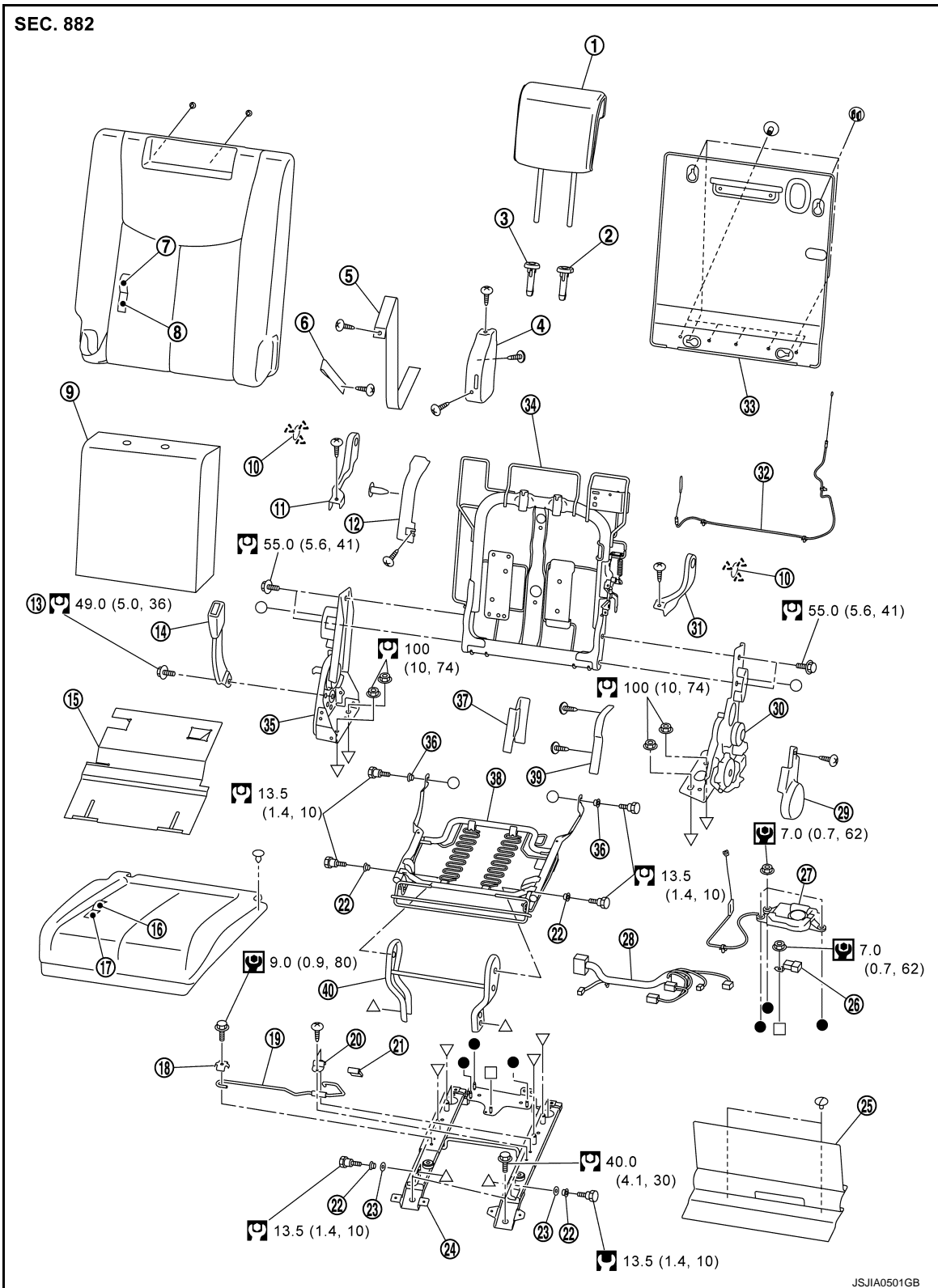



- |                            |                                    |                                    |
|----------------------------|------------------------------------|------------------------------------|
| 1. Headrest                | 2. Headrest holder (locked)        | 3. Headrest holder (free)          |
| 4. Strap link cover        | 5. Seatback strap (rear)           | 6. Seatback strap (front)          |
| 7. Seatback trim           | 8. Seatback pad                    | 9. Seatback silencer               |
| 10. Seat cushion hinge cap | 11. Seat cushion inner hinge cover | 12. Reclining device cover         |
| 13. Anchor bolt            | 14. LH seat belt buckle            | 15. Seat adjuster lower carpet     |
| 16. Seat cushion trim      | 17. Seat cushion pad               | 18. Seat torsion bar inner bracket |

# THIRD SEAT

## < REMOVAL AND INSTALLATION >

- |                                    |                                    |                            |
|------------------------------------|------------------------------------|----------------------------|
| 19. Seat torsion bar               | 20. Seat torsion bar outer bracket | 21. Torsion bar silencer   |
| 22. Bush A                         | 23. Washer                         | 24. Seat adjuster assembly |
| 25. Seat cushion carpet            | 26. Seatback lock relay            | 27. Seatback lock actuator |
| 28. Seat harness assembly          | 29. Seat hinge arm cover           | 30. Seat hinge assembly    |
| 31. Seat cushion outer hinge cover | 32. Reclining cable                | 33. Seatback board         |
| 34. Seatback frame                 | 35. Reclining device assembly      | 36. Bush B                 |
| 37. Reclining arm cover            | 38. Seat cushion frame assembly    | 39. Seat hinge cover       |
| 40. Seat link assembly             |                                    |                            |

 : Pawl

 : N·m (kg-m, ft-lb)

 : N·m (kg-m, in-lb)

●, ○, △, □, ▽ : Indicates that the part is connected at points with same symbol in actual vehicle.

## Removal and Installation

INFOID:0000000011325337

### REMOVAL

#### RH side seat

1. Remove headrest.
2. Remove hook and loop fastener (A) on seat cushion carpet and disengage clips.
3. Remove hook and loop fastener (B) on seat cushion carpet and remove seat cushion carpet.

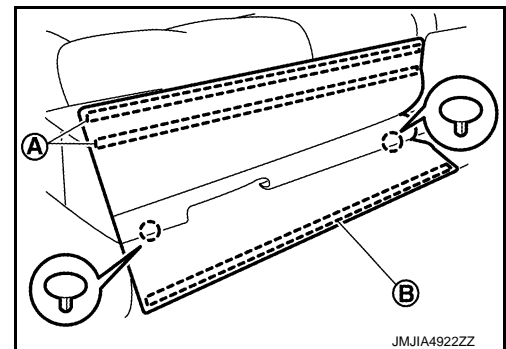

 : Clip

4. Remove front outer mounting bolt.
5. Remove front inner mounting bolt.
6. Operate seatback strap and fold seatback toward vehicle front.
7. Remove luggage floor rear board. Refer to [INT-40, "LUGGAGE FLOOR REAR BOARD : Removal and Installation"](#).
8. Remove cable cover. Refer to [INT-41, "CABLE COVER : Removal and Installation"](#).
9. Remove rear outer mounting bolt.
10. Remove rear inner mounting bolt.
11. Disconnect harness connector (A). (only for seat with seatback power return system or seatback power folding system)

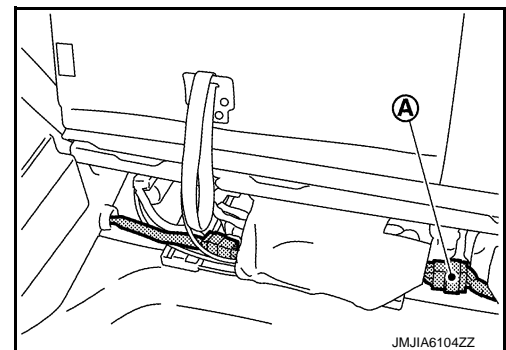

12. Remove seat from the vehicle.

### **CAUTION:**

**When removing and installing, use shop cloths to protect parts from damage.**

# THIRD SEAT

## < REMOVAL AND INSTALLATION >

### LH side seat

1. Remove headrest.
2. Remove hook and loop fastener (A) on seat cushion carpet and disengage clips.
3. Remove hook and loop fastener (B) on seat cushion carpet and remove seat cushion carpet.

 : Clip

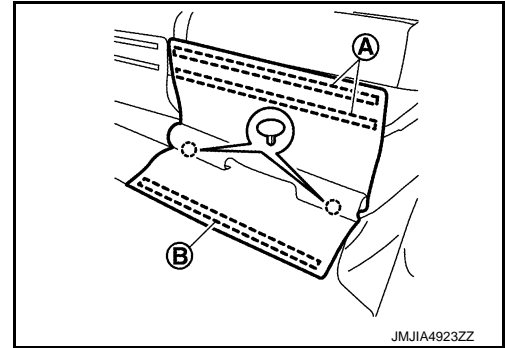

4. Remove front outer mounting bolt.
5. Remove front inner mounting bolt.
6. Operate seatback strap and fold seatback toward vehicle front.
7. Remove luggage floor rear board. Refer to [INT-40, "LUGGAGE FLOOR REAR BOARD : Removal and Installation"](#).
8. Remove cable cover. Refer to [INT-41, "CABLE COVER : Removal and Installation"](#).
9. Remove rear outer mounting bolt.
10. Remove rear inner mounting bolt.
11. Disconnect harness connector (A) and (B). (only for seat with seatback power return system or seatback power folding system)

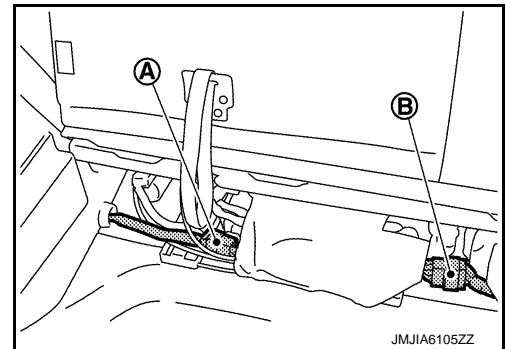

12. Remove seat from the vehicle.

### **CAUTION:**

When removing and installing, use shop cloths to protect parts from damage.

## INSTALLATION

### RH side seat

Note the following items, and install in the reverse order of removal.

### **CAUTION:**

- When removing and installing, use shop cloths to protect parts from damage.
  - Before tightening bolts, check that the carpet is not caught in bolt holes on mounting portion.
  - When installing seat to the vehicle, fold seatback toward vehicle front, and then mount the seat to the vehicle.
  - When installing, tighten mounting bolts according to the numerical order as shown in the figure, starting from rear inner mounting bolt.
- For the specified torque, refer to [SE-123, "Exploded View"](#).

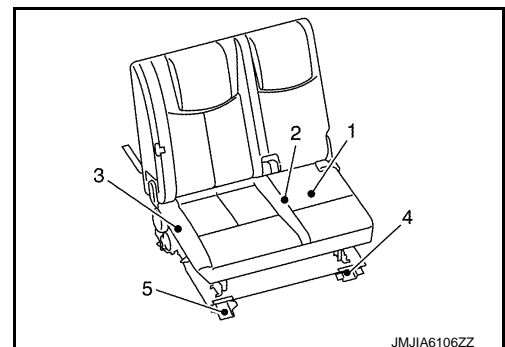

# THIRD SEAT

## < REMOVAL AND INSTALLATION >

LH side seat

Note the following items, and install in the reverse order of removal.

**CAUTION:**

- When removing and installing, use shop cloths to protect parts from damage.
- Before tightening bolts, check that the carpet is not caught in bolt holes on mounting portion.
- When installing seat to the vehicle, fold seatback toward vehicle front, and then mount the seat to the vehicle.
- When installing, tighten mounting bolts according to the numerical order as shown in the figure, starting from rear inner mounting bolt.

For the specified torque, refer to [SE-123. "Exploded View"](#).

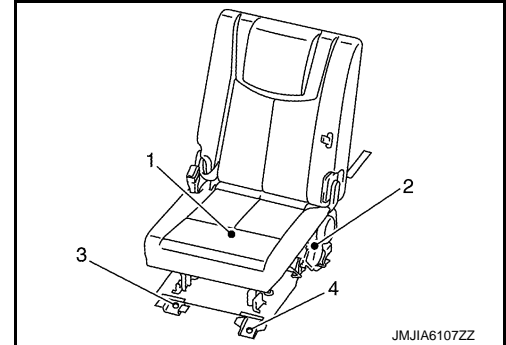

## SEATBACK

### SEATBACK : Disassembly and Assembly

INFOID:000000011325338

#### DISASSEMBLY

RH side seat

1. Remove RH seat belt buckle and center seat belt buckle. Refer to [SB-20. "SEAT BELT BUCKLE : Removal and Installation"](#).
2. Remove seat cushion frame assembly from seatback. Refer to [SE-133. "SEAT CUSHION : Disassembly and Assembly"](#).
3. Remove seatback hook and loop fastener (A).
4. Roll up seatback trim, and then remove seatback trim fixing clips (B).

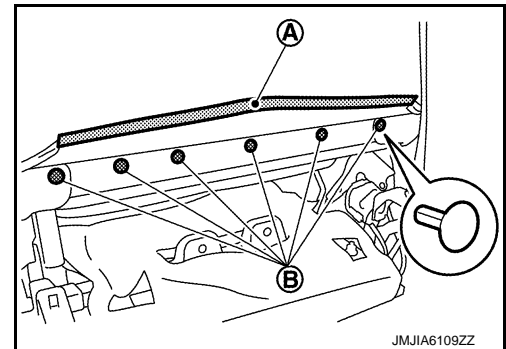

5. Pull up seatback trim (1) to the position where seatback trim mounting clips (A) can be removed.

**CAUTION:**

**Be careful not to damage seatback trim when pulling up seatback trim.**

6. Remove seatback trim fixing clips.

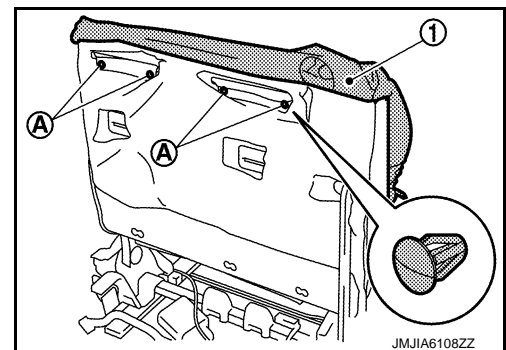

7. Remove seatback board and seatback board fixing clips from seatback frame.



## THIRD SEAT

### < REMOVAL AND INSTALLATION >

- a. Slide and align the clips (B) to the holes on the seatback as shown in the figure, and then remove the seatback board (A).

**CAUTION:**

**Always slide clips before removing seatback board. Clips may be damaged if seatback board is removed without sliding the clips.**

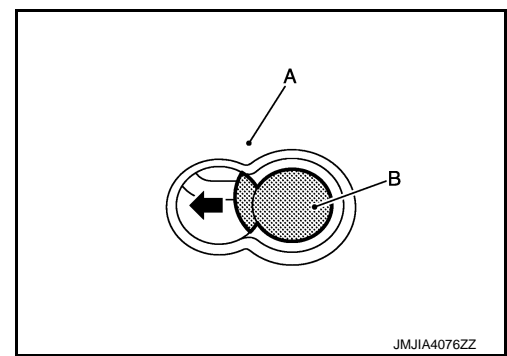

- b. Remove seatback board fixing clips from seatback frame.  
 8. Use pincers, etc., to press up pawls as shown by the arrows in the figure, and remove headrest holder from seatback.

**CAUTION:**

**Before installing headrest holder check its orientation. (front/rear and right/left)**

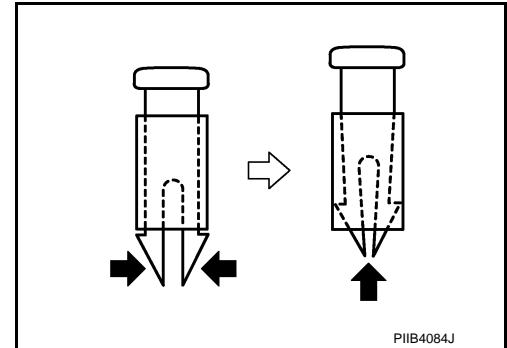

9. Pull out seatback strap from seatback pad.  
 10. Remove seatback trim and seatback pad from seatback frame.  
 11. Remove hog rings, and separate the seatback trim and seatback pad.

**CAUTION:**

**Before performing separating operation, check the installation position of hog rings.**

12. Remove seatback silencer from seatback frame.  
 13. Remove seat hinge assembly and reclining device assembly from seat adjuster assembly.  
 a. Remove seat adjuster lower carpet retainer, and then remove seat adjuster lower carpet from seat adjuster assembly.  
 b. Remove fixing screws, and then remove seat hinge arm cover and seat hinge cover from seat hinge assembly.  
 c. Remove fixing screws and clip, and then remove reclining arm cover and reclining device cover from reclining device assembly.  
 d. Remove following parts from reclining device assembly.  
 i. Remove fixing screw (A), and then remove reclining wire (1).  
 ii. Remove fixing screw (B), and then remove actuator wire (2). (only for seat with seatback power return system or seatback power folding system)  
 iii. Disconnect harness connector (C). (only for seat with seatback power return system)  
 iv. Remove wire clamp (D).

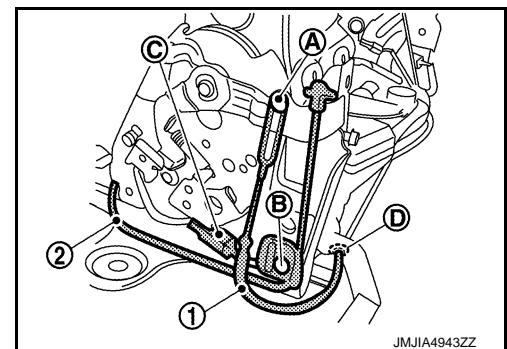

- e. Remove following parts from seat hinge assembly.

A  
B  
C  
D  
E  
F  
G  
H  
I  
K  
L  
M  
N  
O  
P

SE

## THIRD SEAT

### < REMOVAL AND INSTALLATION >

- i. Disconnect harness connector (A) and (B). (only for seat with seatback power return system)
- ii. Remove wire clamp (C).
- iii. Remove wire clamp and harness clamp (only for seat with seatback power return system) (D).

← : Vehicle front

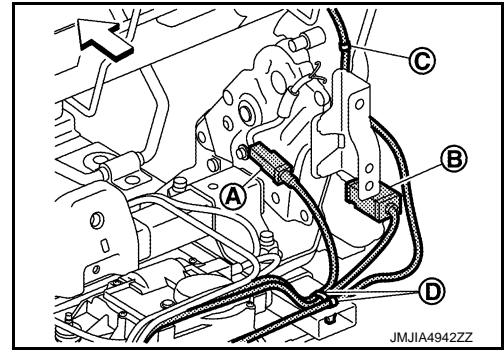

- f. Remove fixing screws, and then remove strap link cover from seatback frame assembly.
- g. Remove reclining wire (2) fixing screw (A) installed on strap link (1).
- h. Remove reclining wire from seat hinge assembly in direction indicated by the arrow as shown in the figure.

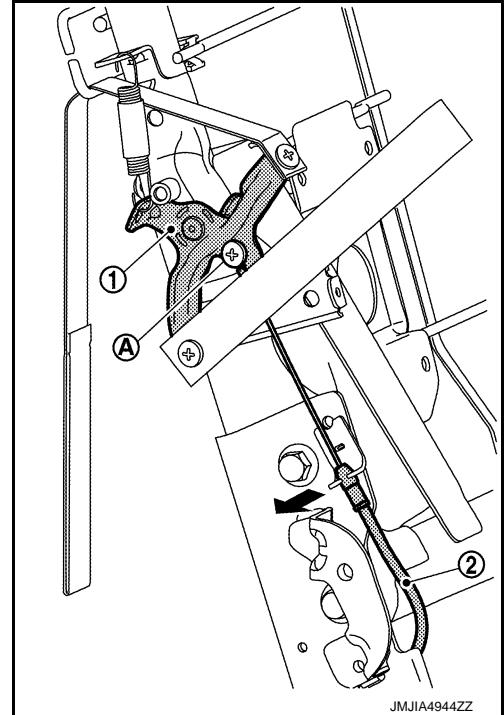

- i. Remove fixing screws, and then remove seatback strap (front and rear).
- j. Remove mounting nuts, and then remove reinforcement pipe assembly from seat adjuster assembly.
- k. Remove seat hinge assembly and reclining device assembly from seat adjuster assembly.
14. Remove mounting bolts, and then remove seat hinge assembly and reclining device assembly from seatback frame assembly.

#### LH side seat

1. Remove LH seat belt buckle. Refer to [SB-20. "SEAT BELT BUCKLE : Removal and Installation"](#).
2. Remove seat cushion frame assembly from seatback frame assembly. Refer to [SE-133. "SEAT CUSHION : Disassembly and Assembly"](#).
3. Remove seatback hook and loop fastener (A).
4. Roll up seatback trim, and then remove fixing clips (B).

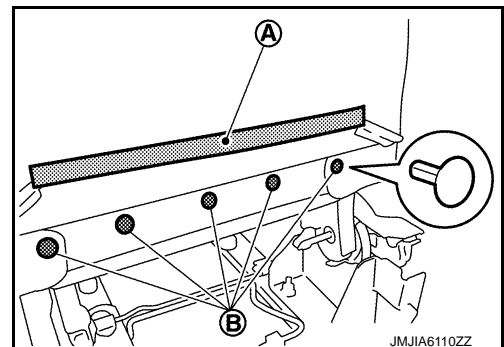

## THIRD SEAT

### < REMOVAL AND INSTALLATION >

5. Pull up seatback trim (1) to the position where seatback trim mounting clips (A) can be removed.

**CAUTION:**

**Be careful not to damage seatback trim when pulling up seatback trim.**

6. Remove seatback trim fixing clips.

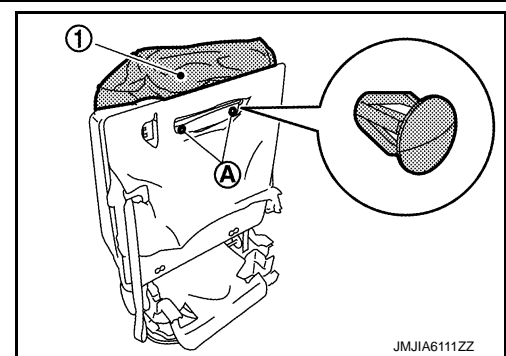

7. Remove seatback board and fixing clips.

- a. Slide and align the clips (B) to the holes on the seatback as shown in the figure, and then remove the seatback board (A).

**CAUTION:**

**Always slide clips before removing seatback board. Clips may be damaged if seatback board is removed without sliding the clips.**

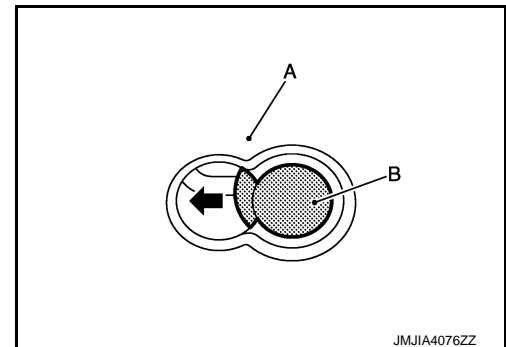

- b. Remove seatback board fixing clips from seatback frame.

8. Use pincers, etc., to press up pawls as shown by the arrows in the figure, and remove headrest holder from seatback.

**CAUTION:**

**Before installing headrest holder check its orientation. (front/rear and right/left)**

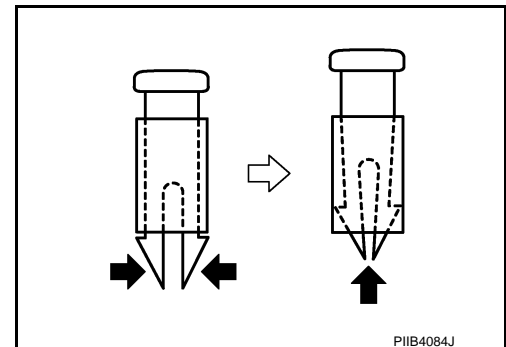

9. Pull out seatback strap from seatback pad.

10. Remove seatback trim and seatback pad from seatback frame assembly.

11. Remove hog rings, and separate the seatback trim and seatback pad.

**CAUTION:**

**Before performing separating operation, check the installation position of hog rings.**

12. Remove seatback silencer from seatback frame.

13. Remove seat hinge assembly and reclining device assembly from seat adjuster assembly.

- a. Remove seat adjuster lower carpet retainer, and then remove seat adjuster assembly from seat adjuster assembly.

- b. Remove fixing screws and clips, and then remove reclining device cover and reclining arm cover from reclining device assembly.

- c. Remove fixing screws, and then remove seat hinge arm cover and seat hinge cover from seat hinge assembly.

- d. Remove following parts from reclining device assembly.

A

B

C

D

E

F

G

H

I

SE

K

L

M

N

O

P

## THIRD SEAT

### < REMOVAL AND INSTALLATION >

- i. Remove fixing screw (A), and then remove reclining wire (1).
- ii. Remove fixing screw (B), and then remove actuator wire (2). (only for seat with seatback power return system or seatback power folding system)
- iii. Remove harness connector clip (C). (only for seat with seatback power return system or seatback power folding system)
- iv. Disconnect harness connector (D). (only for seat with seatback power return system)

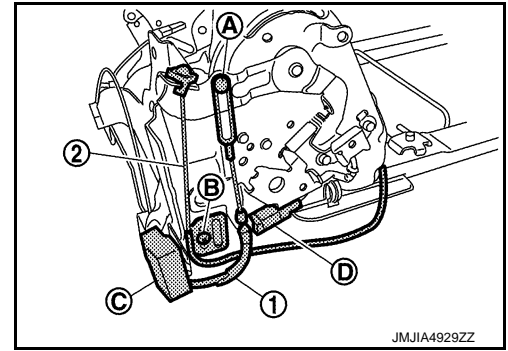

- e. Remove following parts from seat hinge assembly.
  - i. Disconnect harness connector (A) and (B). (only for seat with seatback power return system)
  - ii. Remove wire clamp (C).

← : Vehicle front

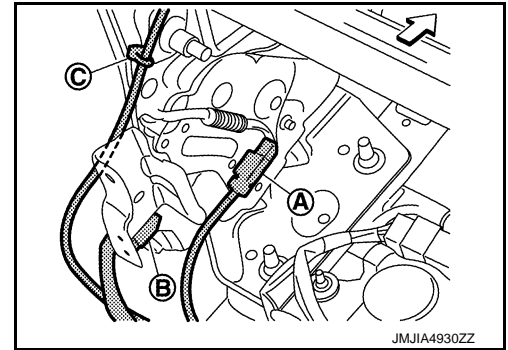

- f. Remove fixing screws, and then remove strap link cover from seatback frame assembly.
- g. Remove reclining wire (2) fixing screw (A) installed on strap link (1).
- h. Remove reclining wire from seat hinge assembly in direction indicated by the arrow as shown in the figure.

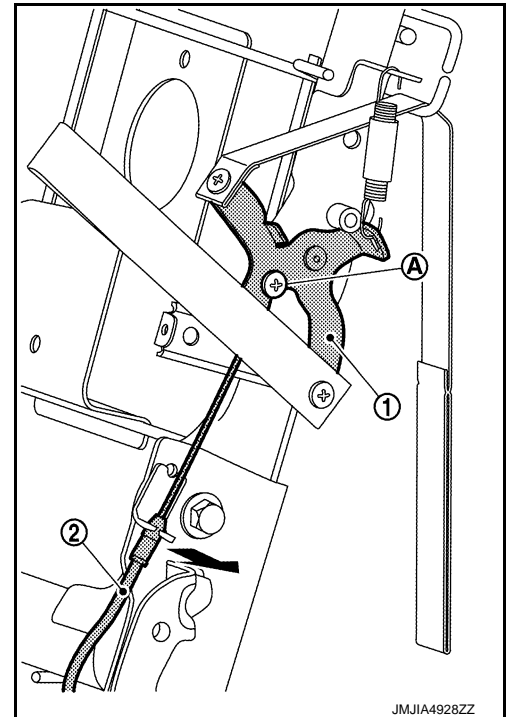

- i. Remove mounting nut, and then remove seat hinge assembly and reclining device assembly from seat adjuster assembly.
14. Remove mounting bolts, and then remove seat hinge assembly and reclining device assembly from seatback frame assembly.

### ASSEMBLY

Note the following, and assemble in the reverse order of disassembly.

#### CAUTION:

- Check seatback trim and seatback pad for damage. Replace with new part if necessary.
- Install hog ring (A) to the specified position as shown in the figure.

# THIRD SEAT

## < REMOVAL AND INSTALLATION >

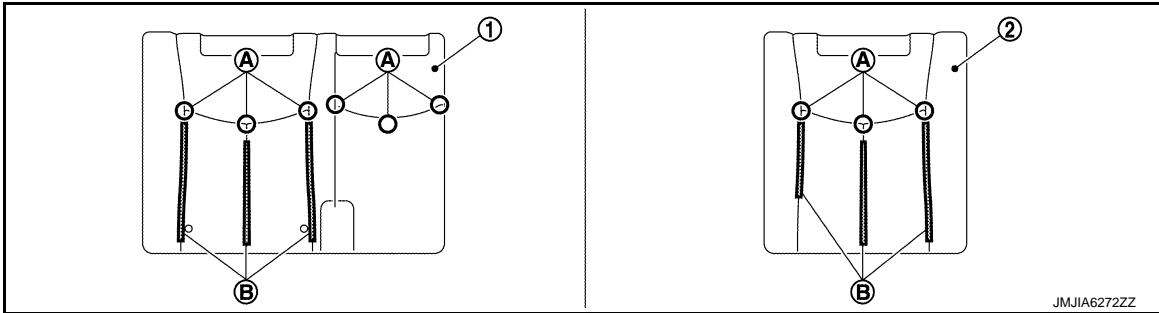

1. Seatback RH
  2. Seatback LH
- B. hook and loop fastener

## SEAT CUSHION

### SEAT CUSHION : Disassembly and Assembly

INFOID:000000011325339

#### DISASSEMBLY

##### RH side seat

1. Remove seat belt connector buckle. Refer to [SB-20. "SEAT BELT BUCKLE : Removal and Installation"](#).
2. Remove seat cushion trim retainer from seat cushion frame assembly.
3. Disengage seat cushion trim fixing clip (A).

 : Clip

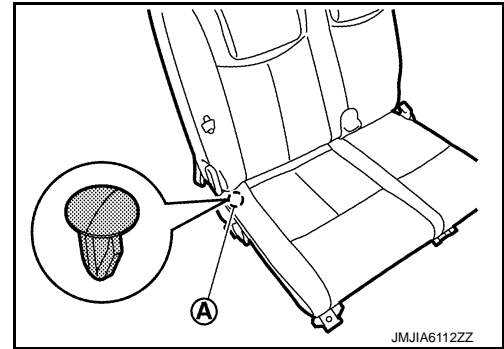

4. Remove seat cushion trim and seat cushion pad from seat cushion frame assembly.
5. Remove hog rings, and separate the seatback trim and seatback pad.

#### **CAUTION:**

**Before performing separating operation, check the installation position of hog rings.**

6. Remove seat cushion frame assembly from seatback.
  - a. Remove mounting bolts, and then remove seat cushion frame assembly from seat link assembly.
  - b. Disengage pawls using a screwdriver (A), and then remove seat cushion hinge cover cap of the seat cushion outer hinge cover and seat cushion inner hinge cover.

 : Pawl

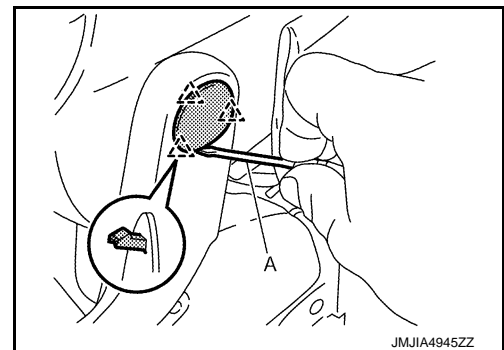

- c. Remove mounting bolts, and then remove seat cushion frame assembly from seatback.
7. Remove following parts from seat cushion frame assembly.
  - Remove fixing screw, and then remove seat cushion outer hinge cover.
  - Remove fixing screw, and then remove seat cushion inner hinge cover.

## THIRD SEAT

### < REMOVAL AND INSTALLATION >

8. Remove mounting bolts, and then remove seat link assembly from seat adjuster assembly.
9. Remove mounting nuts, and then remove reinforcement pipe assembly, seat hinge assembly and reclining device assembly from seat adjuster assembly.  
Refer to [SE-128. "SEATBACK : Disassembly and Assembly"](#).
10. Remove control unit bracket from reinforcement pipe assembly. (only for seat with seatback power return system)
  - a. Disconnect harness connector.
  - b. Remove mounting nuts, and then remove seatback power return control unit.
  - c. Remove harness clamp installed on control unit bracket.
  - d. Remove fixing screws, and then remove control unit bracket.
11. Remove actuator bracket from reinforcement pipe assembly. (only for seat with seatback power return system or seatback power folding system)
  - a. Disconnect harness connector.
  - b. Remove fixing nuts and wire clamp, and then remove seatback lock release actuator from actuator bracket.
  - c. Disconnect harness connector, and then remove seatback lock release relay.
  - d. Remove fixing screw, and then remove actuator bracket.
12. Remove seat harness assembly from seat adjuster assembly. (only for seat with seatback power return system or seatback power folding system)
13. Remove seat torsion bar.
  - a. Remove mounting bolt, and then remove seat torsion bar inner bracket.
  - b. Remove fixing screws, and then remove seat torsion bar outer bracket.
  - c. Remove seat torsion bar from seat adjuster assembly.
14. Remove seat torsion bar silencer from seat torsion bar.

#### LH side seat

1. Remove LH seat belt buckle. Refer to [SB-20. "SEAT BELT BUCKLE : Removal and Installation"](#).
2. Remove seat cushion trim retainer from seat cushion frame assembly.
3. Disengage seat cushion trim fixing clip (A).

 : Clip

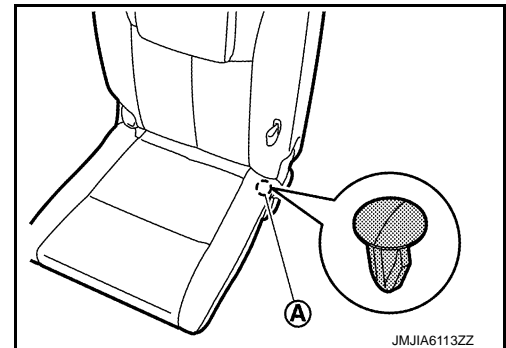

4. Remove seat cushion trim and seat cushion pad from seat cushion frame assembly.
5. Remove hog rings, and separate the seatback trim and seatback pad.  
**CAUTION:**  
**Before performing separating operation, check the installation position of hog rings.**
6. Remove seat cushion frame assembly from seatback.
  - a. Remove mounting bolt, and then remove seat cushion frame assembly from seat link assembly.

# THIRD SEAT

## < REMOVAL AND INSTALLATION >

- b. Disengage pawls using a screwdriver (A), and then remove seat cushion hinge cover cap of the seat cushion outer hinge cover and seat cushion inner hinge cover.

 : Pawl

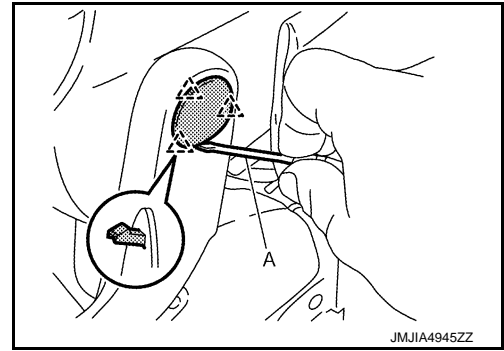

- c. Remove mounting bolts, and then remove seat cushion frame assembly from seatback.
7. Remove following parts from seat cushion frame assembly.
- Remove fixing screw, and then remove seat cushion outer hinge cover.
  - Remove fixing screw, and then remove seat cushion inner hinge cover.
8. Remove mounting bolts, and then remove seat link assembly from seat adjuster assembly.
9. Remove mounting nuts, and then remove seat hinge assembly and reclining device assembly from seat adjuster assembly.  
Refer to [SE-128, "SEATBACK : Disassembly and Assembly"](#).
10. Remove seatback lock release actuator. (only for seat with seatback power return system or seatback power folding system)
- a. Disconnect harness connector.
- b. Remove fixing nuts and wire clamp, and then remove seatback lock release actuator from seat adjuster assembly.
11. Remove seatback lock release relay. (only for seat with seatback power return system or seatback power folding system)
- a. Disconnect harness connector.
- b. Remove mounting nut, and then remove seatback lock release relay from seat adjuster assembly.
12. Remove seat harness assembly from seat adjuster assembly. (only for seat with seatback power return system or seatback power folding system)
13. Remove seat torsion bar.
- a. Remove mounting bolt, and then remove seat torsion bar inner bracket.
- b. Remove fixing screws, and then remove seat torsion bar outer bracket.
- c. Remove seat torsion bar from seat adjuster assembly.
14. Remove seat torsion bar silencer from seat torsion bar.

## ASSEMBLY

Note the following, and assemble in the reverse order of disassembly.

### CAUTION:

- Check seat cushion trim and seat cushion pad for damage. Replace with new part if necessary.
- Install seat cushion front hog rings (A) and seat cushion back hog rings (B) to the specified positions.

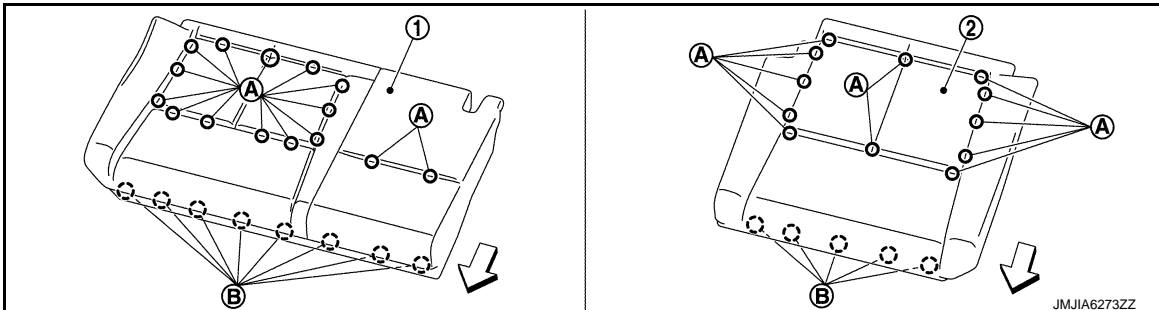

1. Seat cushion RH

2. Seat cushion LH

 : Vehicle front

## THIRD SEAT

### < REMOVAL AND INSTALLATION >

---

- If crimping using a hog ring is unsuccessful, secure using a new hog ring.
- Tighten seat belt buckle anchor bolt to the specified torque.  
For the specified torque, refer to [SE-123, "Exploded View"](#).



# THIRD SEAT FOLD SWITCH

< REMOVAL AND INSTALLATION >

## THIRD SEAT FOLD SWITCH

### Removal and Installation

INFOID:000000011325340

#### REMOVAL

1. Remove luggage side lower finisher. Refer to [INT-43. "LUGGAGE SIDE LOWER FINISHER : Removal and Installation"](#).
2. Remove third seat fold switch (1) from luggage side lower finisher using remover tool (A).

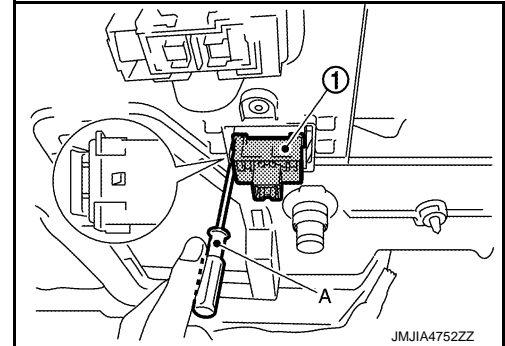

#### INSTALLATION

Install in the reverse order of removal.

A  
B  
C  
D  
E  
F  
G  
H  
I

SE

K  
L  
M  
N  
O  
P

# LUMBAR SUPPORT SWITCH

< REMOVAL AND INSTALLATION >

## LUMBAR SUPPORT SWITCH

### Removal and Installation

INFOID:000000011325341

#### REMOVAL

1. Remove seat cushion inner finisher (For manual seat. Refer to [SE-89, "Removal and Installation"](#)) or outer finisher (For power seat. Refer to [SE-103, "Removal and Installation"](#)).
2. Remove lumbar support switch (1) from seat cushion finisher.

 : Pawl

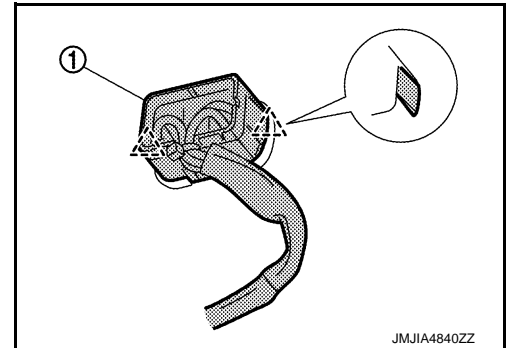

#### INSTALLRATION

Install in the reverse order of removal.

# HEATED SEAT SWITCH

< REMOVAL AND INSTALLATION >

## HEATED SEAT SWITCH

### Removal and Installation

INFOID:000000011325342

#### REMOVAL

1. Remove instrument lower center panel. Refer to [IP-14](#), "[Removal and Installation](#)".
2. Remove heated seat switch (1) from instrument lower center panel using remover tool (A).

 : Pawl

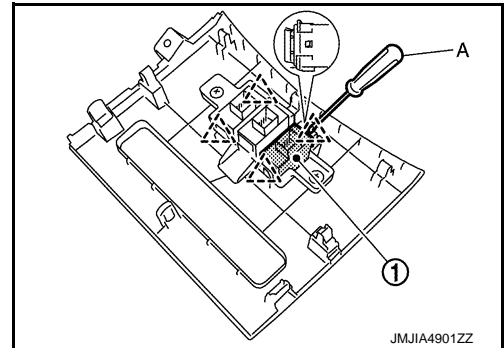

#### INSTALLRATION

Install in the reverse order of removal.

A  
B  
C  
D  
E  
F  
G  
H  
I  
K  
L  
M  
N  
O  
P

SE

# SEATBACK POWER RETURN CONTROL UNIT

< REMOVAL AND INSTALLATION >

## SEATBACK POWER RETURN CONTROL UNIT

### Removal and Installation

INFOID:000000011325343

#### REMOVAL

1. Remove luggage floor front board. Refer to [INT-42. "LUGGAGE FLOOR FRONT BOARD : Removal and Installation"](#).
2. Remove screws (A), and then remove seatback power return control unit (1).

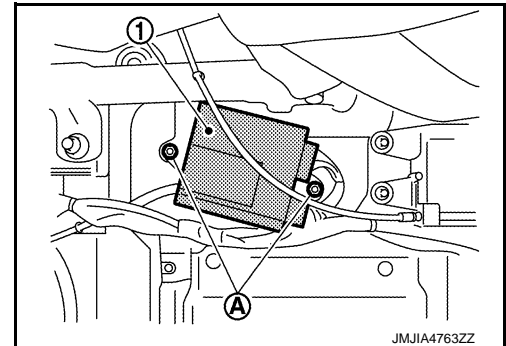

#### INSTALLRATION

Install in the reverse order of removal.