

A  
B  
C

# SECTION **PB**

## PARKING BRAKE SYSTEM

### CONTENTS

<p><b>PRECAUTION</b> ..... 2</p> <p><b>PRECAUTIONS</b> ..... 2</p> <p style="padding-left: 20px;">Precautions for Removing Battery Terminal .....2</p> <p><b>PREPARATION</b> ..... 3</p> <p><b>PREPARATION</b> ..... 3</p> <p style="padding-left: 20px;">Commercial Service Tool .....3</p> <p><b>PERIODIC MAINTENANCE</b> ..... 4</p> <p><b>PARKING BRAKE SYSTEM</b> ..... 4</p> <p style="padding-left: 20px;">Inspection and Adjustment .....4</p> <p><b>PARKING BRAKE SHOE</b> ..... 6</p> <p style="padding-left: 20px;">Adjustment .....6</p> <p><b>REMOVAL AND INSTALLATION</b> ..... 7</p>	<p><b>PARKING BRAKE CONTROL</b> ..... 7</p> <p style="padding-left: 20px;">Exploded View ..... 7</p> <p style="padding-left: 20px;">Removal and Installation ..... 7</p> <p style="padding-left: 20px;">Adjustment ..... 8</p> <p><b>PARKING BRAKE SHOE</b> ..... 9</p> <p style="padding-left: 20px;">Exploded View ..... 9</p> <p style="padding-left: 20px;">Removal and Installation ..... 9</p> <p style="padding-left: 20px;">Inspection and Adjustment .....10</p> <p><b>SERVICE DATA AND SPECIFICATIONS (SDS)</b> .....12</p> <p><b>SERVICE DATA AND SPECIFICATIONS (SDS)</b> .....12</p> <p style="padding-left: 20px;">Parking Drum Brake .....12</p> <p style="padding-left: 20px;">Parking Brake Control .....12</p>
---	--

A  
B  
C  
D  
E  
**PB**  
G  
H  
I  
J  
K  
L  
M  
N  
O  
P

# PRECAUTIONS

< PRECAUTION >

## PRECAUTION

### PRECAUTIONS

#### Precautions for Removing Battery Terminal

INFOID:0000000012405134

- When removing the 12V battery terminal, turn OFF the ignition switch and wait at least 30 seconds.

**NOTE:**

ECU may be active for several tens of seconds after the ignition switch is turned OFF. If the battery terminal is removed before ECU stops, then a DTC detection error or ECU data corruption may occur.

- For vehicles with the 2-batteries, be sure to connect the main battery and the sub battery before turning ON the ignition switch.

**NOTE:**

If the ignition switch is turned ON with any one of the terminals of main battery and sub battery disconnected, then DTC may be detected.

- After installing the 12V battery, always check "Self Diagnosis Result" of all ECUs and erase DTC.

**NOTE:**

The removal of 12V battery may cause a DTC detection error.

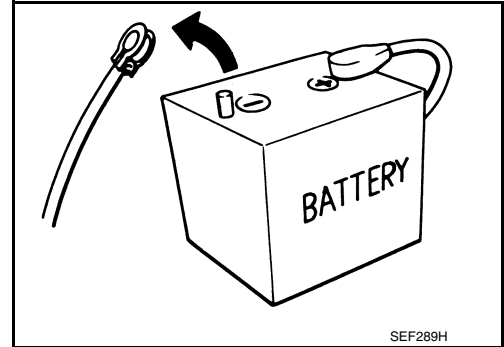

# PREPARATION

< PREPARATION >

## PREPARATION

### PREPARATION

#### Commercial Service Tool

INFOID:0000000012405135

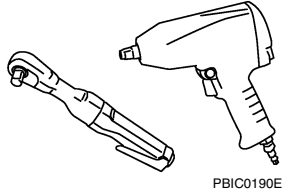
Tool name	Description
Power tool 	Loosening bolts and nuts

A

B

C

D

E

PB

G

H

I

J

K

L

M

N

O

P

# PARKING BRAKE SYSTEM

< PERIODIC MAINTENANCE >

## PERIODIC MAINTENANCE

### PARKING BRAKE SYSTEM

#### Inspection and Adjustment

INFOID:000000012405136

#### INSPECTION

##### Pedal Stroke

1. Operate the parking brake pedal with a force of 196 N (20 kg, 44 lb). Check that the pedal stroke is within the specified number of notches. (Check it by listening to the clicks of the ratchet.)

**Number of notches** : Refer to [PB-12, "Parking Brake Control"](#).

2. When brake warning lamp turns ON, check that the pedal stroke is within the specified number of notches. (Check it by listening to the clicks of the ratchet.)

**Number of notches** : Refer to [PB-12, "Parking Brake Control"](#).

##### Inspect Components

- Check each component for installation condition such as looseness.
- Check the parking brake pedal assembly for bend, damage and cracks. Replace if necessary.
- Check the cables and equalizer for wear, damage and cracks. Replace if necessary.
- Check the parking brake switch, and replace it if necessary. Refer to [BRC-120, "Component Inspection"](#).

#### ADJUSTMENT

1. Remove rear tires with power tool.
2. Fix the disc rotor using wheel nut.
3. Remove fuse block lid. Refer to [IP-14, "Removal and Installation"](#).
4. Release the parking brake pedal (1) by turning the adjusting nut (2) with a deep socket wrench and loosening the cable.

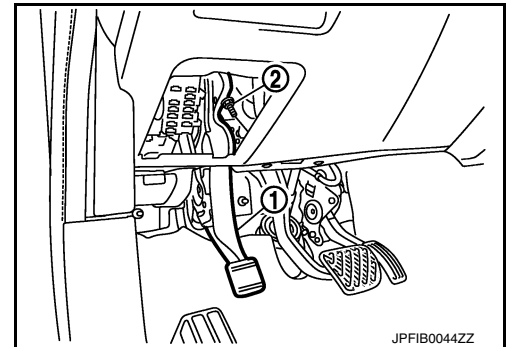

5. Remove the adjusting hole plug from the disc rotor. Turn the adjuster (1) in the direction (A) as shown in the figure using a suitable tool until the disc rotor is locked.
6. Turn back the adjuster 5 to 6 notches from the locked position.
7. Rotate the disc rotor to check that there is no drag. Install the adjuster hole plug. If any drag is found follow the procedure described below.

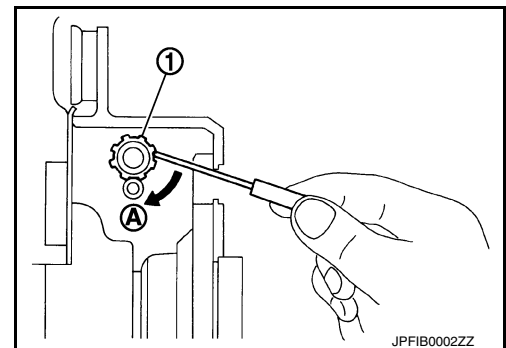

- a. Adjust parking brake stroke again.
  - b. Check rear disc brake. Refer to [BR-52, "BRAKE CALIPER ASSEMBLY : Inspection"](#).
8. Adjust the cable with the following procedure.
    - a. Temporarily adjust the cable so that the parking brake pedal operating force immediately before the full stroke reaches 490 N (50 kg, 110 lb) or more.
    - b. Operate the parking brake pedal with a force of 490 N (50 kg, 110 lb) for 10 strokes or more.

## PARKING BRAKE SYSTEM

### < PERIODIC MAINTENANCE >

- c. Adjust the parking brake pedal (1) stroke by turning the adjusting nut (2) with a socket wrench.

**CAUTION:**

**Never reuse the adjusting nut if the nut is removed.**

- d. Operate the parking brake pedal with a force of 196 N (20 kg, 44 lb). Check that the pedal stroke is within the specified number of notches. (Check it by listening to the clicks of the ratchet.)

**Number of notches** : Refer to [PB-12, "Parking Brake Control"](#).

- e. Rotate the disc rotor to check that there is no drag. Install the plug. If any drag is found, follow the procedure described below.
- i. Adjust parking brake stroke again.
- ii. Check rear disc brake. Refer to [BR-52, "BRAKE CALIPER ASSEMBLY : Inspection"](#).

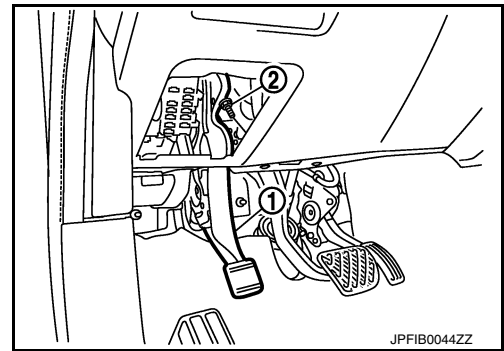

A  
B  
C  
D  
E  
G  
H  
I  
J  
K  
L  
M  
N  
O  
P

PB

# PARKING BRAKE SHOE

< PERIODIC MAINTENANCE >

---

## PARKING BRAKE SHOE

### Adjustment

INFOID:000000012405137

1. Adjust parking brake pedal stroke. Refer to [PB-4, "Inspection and Adjustment"](#).
2. Perform parking brake break-in (drag on) operation by driving vehicle under the following conditions or equivalency conditions:
  - Drive forward
  - Vehicle speed: Approx. 80 km/h (50 MPH) set (constant and forward)
  - Parking brake operating force: 177.5 N (18.2 kg, 40.0 lb) set contact
  - Time: Approx. 16 sec.

**CAUTION:**

- To prevent lining from getting too hot, allow a cool off period of approximately 5 minutes after every break-in operation.
  - Never perform excessive break-in operations, because doing so may cause uneven or early wear of the lining.
3. After the break-in procedure, check parking brake pedal stroke of parking brake.

**CAUTION:**

If it is out of the specification, adjust again. Refer to [PB-4, "Inspection and Adjustment"](#).

# PARKING BRAKE CONTROL

< REMOVAL AND INSTALLATION >

## REMOVAL AND INSTALLATION

### PARKING BRAKE CONTROL

Exploded View

INFOID:0000000012405138

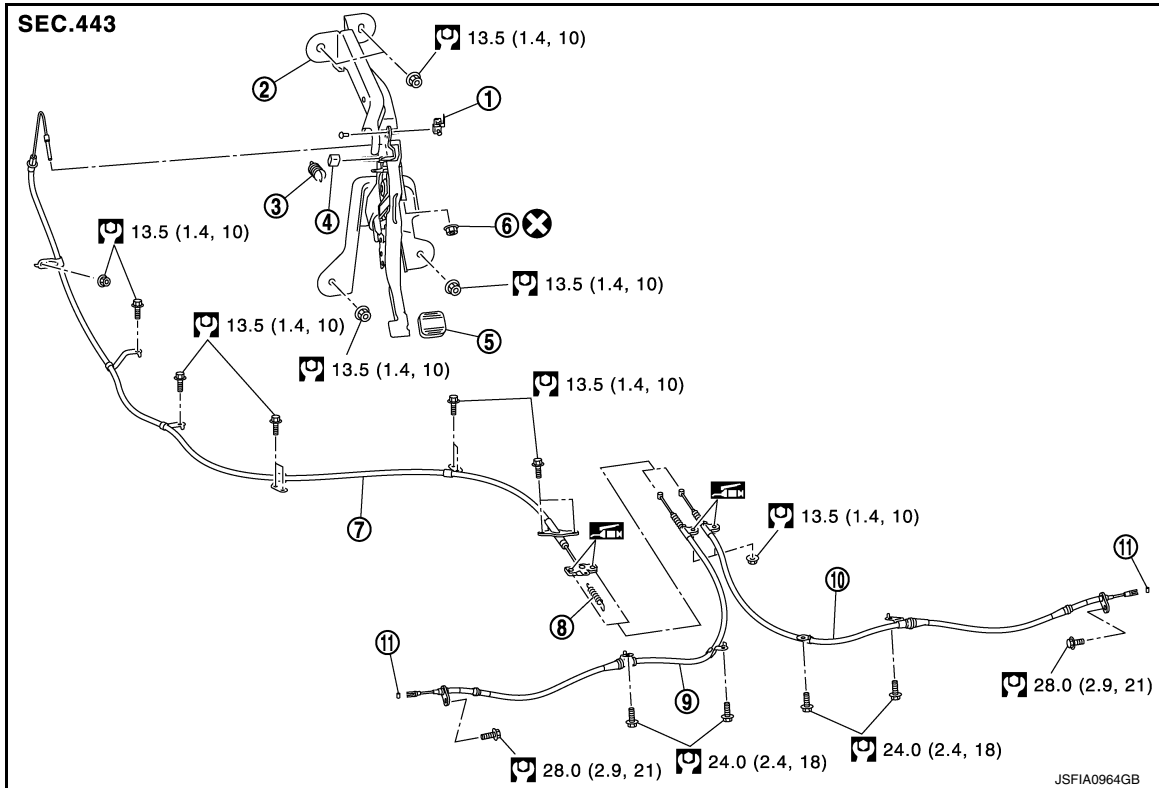

- |                         |                                 |                    |
|-------------------------|---------------------------------|--------------------|
| 1. Parking brake switch | 2. Parking brake pedal assembly | 3. Return spring   |
| 4. Stopper rubber       | 5. Pedal pad                    | 6. Adjusting nut   |
| 7. Front cable          | 8. Spring                       | 9. Rear cable (LH) |
| 10. Rear cable (RH)     | 11. Pin                         |                    |

: Apply multi-purpose grease.

: N·m (kg-m, ft-lb)

: Always replace after every disassembly.

### Removal and Installation

INFOID:0000000012405139

#### REMOVAL

1. Remove rear tires with power tool.
2. Remove the instrument lower panel LH. Refer to [IP-14, "Removal and Installation"](#).
3. Disconnect the parking brake switch harness connector.
4. Remove adjusting nut and loosen front cable.
5. Remove the parking brake pedal assembly.
6. Remove dash side finisher. Refer to [INT-24, "DASH SIDE FINISHER : Removal and Installation"](#).
7. Remove front kicking plate. Refer to [INT-22, "KICKING PLATE : Removal and Installation"](#).
8. Remove front seat (driver side).
  - Manual seat: Refer to [SE-91, "Removal and Installation"](#).
  - Power seat: Refer to [SE-105, "Removal and Installation"](#).
9. Remove seat slide rail of second seat. Refer to [SE-117, "Removal and Installation"](#).

## PARKING BRAKE CONTROL

### < REMOVAL AND INSTALLATION >

---

10. Remove floor carpet. Refer to [INT-30, "FRONT FLOOR CARPET : Removal and Installation"](#).
11. Remove center muffler and heat plate. Refer to [EX-6, "Removal and Installation"](#).
12. Separate front cable from rear cable, and remove front cable and spring.
13. Remove brake shoe. Refer to [PB-9, "Exploded View"](#).
14. Remove rear cable from toggle lever.

### INSTALLATION

Note the following, install in the reverse order of the removal.

- Never reuse adjusting nut.
- Perform adjustment after installation. Refer to [PB-4, "Inspection and Adjustment"](#).

### Adjustment

INFOID:0000000012405140

### ADJUSTMENT AFTER INSTALLATION

Adjust the parking brake pedal stroke. Refer to [PB-4, "Inspection and Adjustment"](#).



# PARKING BRAKE SHOE

< REMOVAL AND INSTALLATION >

## PARKING BRAKE SHOE

Exploded View

INFOID:000000012405141

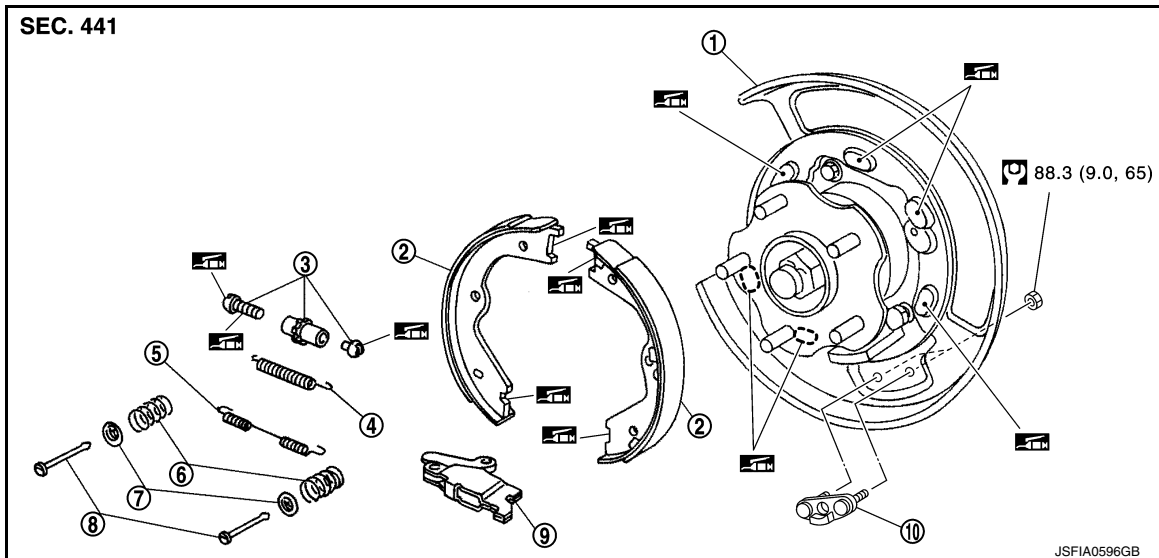

- |                    |                       |                 |
|--------------------|-----------------------|-----------------|
| 1. Back plate      | 2. Parking brake shoe | 3. Adjuster     |
| 4. Adjuster spring | 5. Return spring      | 6. Spring       |
| 7. Retainer        | 8. Anti-rattle pin    | 9. Toggle lever |
| 10. Anchor block   |                       |                 |

: Apply PBC (Poly Butyl Cuprysil) grease or silicone-based grease.

: N·m (kg·m, ft·lb)

## Removal and Installation

INFOID:000000012405142

### REMOVAL

#### **WARNING:**

Since dust covering the parking brake has an affect on human body, the dust must be removed with a dust collector. Never splatter the dust with an air blow gun.

1. Remove rear tires with power tool.
2. Remove disc rotor. Refer to [RAX-7, "Removal and Installation"](#).
3. While pushing and rotating the anti-rattle pin (1), remove anti-rattle pin return, retainer and spring.

#### **CAUTION:**

Never drop the removed parts.

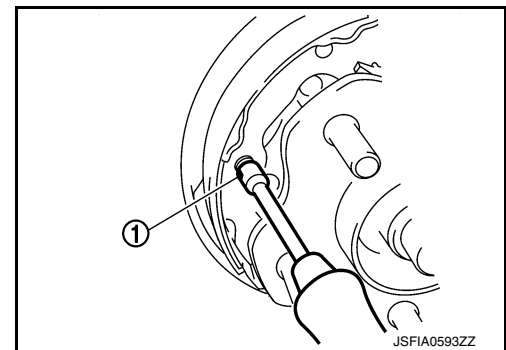

# PARKING BRAKE SHOE

## < REMOVAL AND INSTALLATION >

4. Remove adjuster spring (1).

**CAUTION:**

Never drop the removed parts.

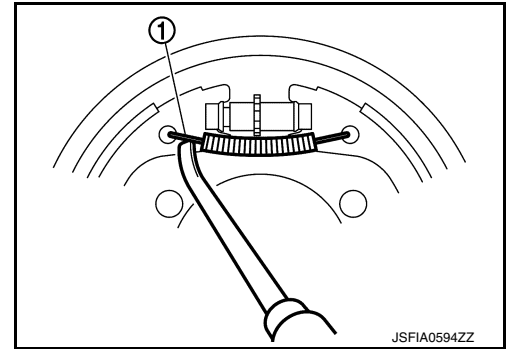

5. Remove return spring (1).

**CAUTION:**

Never drop the removed parts.

6. Remove adjuster, parking brake shoes, toggle lever and Anchor block.

**CAUTION:**

- The parking brake shoes for the front wheels are made of different materials from those for the rear wheels. Never misidentify them when removing.
- Never drop the removed parts.

7. For the removal of back plate. Refer to [RAX-7, "Removal and Installation"](#).

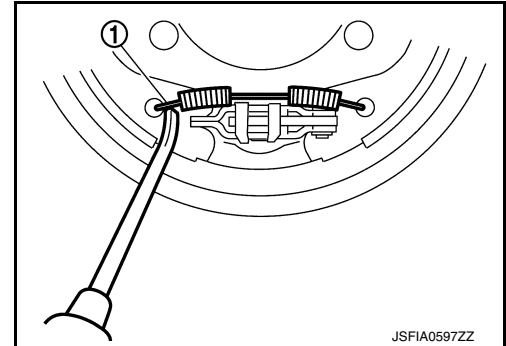

## INSTALLATION

Note the following, install in the reverse order of removal.

- Apply PBC (Poly Butyl Cuprysil) grease or silicone-based grease to the back plate and brake shoe.
- The parking brake shoes for the front wheels are made of different materials from those for the rear wheels. Never misidentify them when removing and replacing.
- Assemble adjusters so that threaded part is expanded when rotating it in the direction shown by arrow.

A : For right side brake

B : For left side brake

↔: Vehicle front

←: Adjuster expands

- Shorten adjuster by rotating it.
- When disassembling apply PBC (Poly Butyl Cuprysil) grease or silicone-based grease to threads.

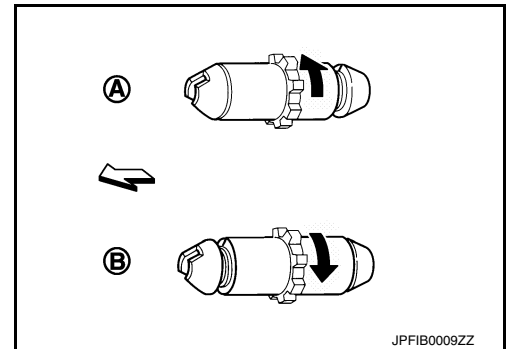

- Check that the component parts of the parking brake shoe are properly installed.
- Check brake shoe sliding surface and drum inner surface for grease. Wipe it off if it adhere on the surfaces.

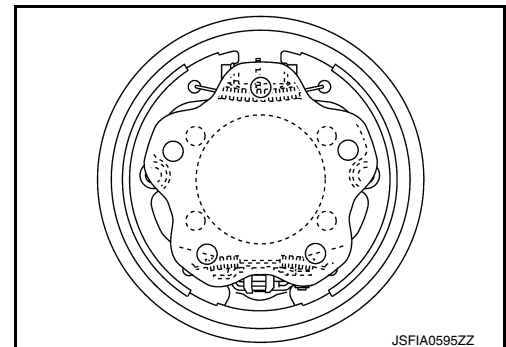

## Inspection and Adjustment

INFOID:000000012405143

## INSPECTION AFTER REMOVAL

Lining Thickness Inspection

# PARKING BRAKE SHOE

## < REMOVAL AND INSTALLATION >

- Check thickness (A) of lining.

**A** : Refer to [PB-12, "Parking Drum Brake"](#).

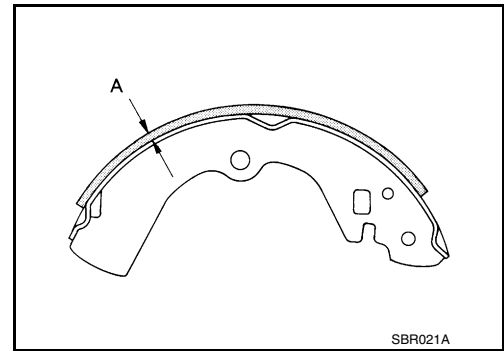

### Drum Inner Diameter Inspection

- Check inner diameter (B) of drum.

**B** : Refer to [PB-12, "Parking Drum Brake"](#).

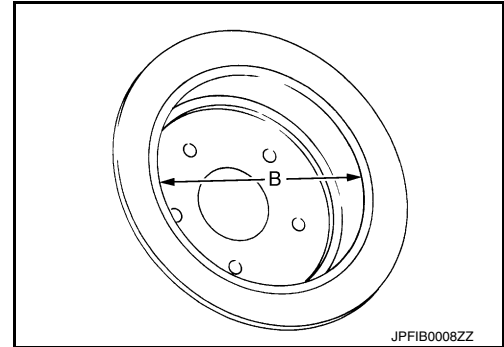

### Other Inspections

Check the following items, and replace the parts if necessary.

- Lining for excessive wear, damage, and peeling.
- Anti-rattle pin for excessive wear, damage and rust.
- Return spring and spring for settling, excessive wear, damage, and rust.
- Adjuster for smoothness.
- Toggle pedal and brake strut for excessive wear, damage and rust.
- Visually check inside of the drum for excessive wear, cracks, and damage with a pair of vernier calipers.

### ADJUSTMENT AFTER INSTALLATION

1. Adjust the parking brake pedal stroke. Refer to [PB-4, "Inspection and Adjustment"](#).
2. Rotate the disc rotor to check that there is no drag. Install the plug. If any drag is found, follow the procedure described below.
  - a. Adjust parking brake stroke again.
  - b. Check rear disc brake. Refer to [BR-52, "BRAKE CALIPER ASSEMBLY : Inspection"](#).

## SERVICE DATA AND SPECIFICATIONS (SDS)

< SERVICE DATA AND SPECIFICATIONS (SDS)

## SERVICE DATA AND SPECIFICATIONS (SDS)

### SERVICE DATA AND SPECIFICATIONS (SDS)

#### Parking Drum Brake

INFOID:0000000012405144

Unit: mm (in)

Item	Limit
Brake lining	1.5 (0.059)
Drum (disc of inner diameter)	191 (7.52)

#### Parking Brake Control

INFOID:0000000012405145

Item	Standard
Number of notches [under force of 196 N (20 kg, 44 lb)]	7 – 8 notches
Number of notches when brake warning lamp turns ON	1 notch