

# SECTION **SRC**

## SRS AIRBAG CONTROL SYSTEM

A  
B  
C  
D  
E  
F  
G  
I  
J  
K  
L  
M  
N  
O  
P

### CONTENTS

**FOR USA AND CANADA**

<p><b>BASIC INSPECTION</b> ..... 8</p> <p><b>DIAGNOSIS AND REPAIR WORK FLOW</b> ..... 8 Work Flow .....8</p> <p><b>SYSTEM DESCRIPTION</b> .....10</p> <p><b>SRS AIR BAG SYSTEM</b> .....10 System Diagram ..... 10 System Description ..... 10 Component Parts Location ..... 11 Component Description ..... 12</p> <p><b>OCCUPANT CLASSIFICATION SYSTEM</b> .....13 System Diagram ..... 13 System Description ..... 13 Component Parts Location ..... 13 Component Description ..... 14</p> <p><b>PASSENGER SEAT BELT WARNING SYSTEM</b> .....15 System Diagram ..... 15 System Description ..... 15 Component Parts Location ..... 16 Component Description ..... 17</p> <p><b>DIAGNOSIS SYSTEM (AIRBAG)</b> .....18 Diagnosis Description ..... 18 CONSULT-III Function ..... 20</p> <p><b>DTC/CIRCUIT DIAGNOSIS</b> .....22</p> <p><b>B1001, B1002, B1003, B1004, B1005 DIAGNOSIS SENSOR UNIT</b> .....22 Description ..... 22 DTC Logic ..... 22 Diagnosis Procedure ..... 23</p> <p><b>B1006, B1007, B1008, B1009, B1010 DIAGNOSIS SENSOR UNIT</b> .....24</p>	<p>Description .....24 DTC Logic .....24 Diagnosis Procedure .....25</p> <p><b>B1011, B1012, B1013, B1014, B1015 DIAGNOSIS SENSOR UNIT</b> .....26 Description .....26 DTC Logic .....26 Diagnosis Procedure .....27</p> <p><b>B1017, B1020, B1021 OCCUPANT SENS C/U</b> .....28 Description .....28 DTC Logic .....28 Diagnosis Procedure .....29</p> <p><b>B1018 OCCUPANT SENS</b> .....30 Description .....30 DTC Logic .....30 Diagnosis Procedure .....31</p> <p><b>B1022 OCCUPANT SENS C/U</b> .....32 Description .....32 DTC Logic .....32 Diagnosis Procedure .....33</p> <p><b>B1023 PASS A/B INDCTR CKT</b> .....34 Description .....34 DTC Logic .....34 Diagnosis Procedure .....35</p> <p><b>B1026, B1027, B1028, B1029, B1030, B1031 DIAGNOSIS SENSOR UNIT</b> .....36 Description .....36 DTC Logic .....36 Diagnosis Procedure .....37</p> <p><b>B1033, B1034 CRASH ZONE SEN</b> .....38 Description .....38 DTC Logic .....38 Diagnosis Procedure .....39</p>
---	---

SRC

<b>B1035, B1036, B1038, B1040 CRASH ZONE SEN</b> .....	40	DTC Logic .....	66
Description .....	40	Diagnosis Procedure .....	67
DTC Logic .....	40	<b>B1081 PRE-TEN FRONT RH</b> .....	68
Diagnosis Procedure .....	41	Description .....	68
<b>B1042, B1043, B1044, B1045, B1046, B1047 DIAGNOSIS SENSOR UNIT</b> .....	42	DTC Logic .....	68
Description .....	42	Diagnosis Procedure .....	69
DTC Logic .....	42	<b>B1082 PRE-TEN FRONT RH</b> .....	70
Diagnosis Procedure .....	43	Description .....	70
<b>B1049, B1054 DRIVER AIRBAG MODULE</b> .....	44	DTC Logic .....	70
Description .....	44	Diagnosis Procedure .....	71
DTC Logic .....	44	<b>B1083 PRE-TEN FRONT RH</b> .....	72
Diagnosis Procedure .....	45	Description .....	72
<b>B1050, B1055 DRIVER AIRBAG MODULE</b> .....	47	DTC Logic .....	72
Description .....	47	Diagnosis Procedure .....	73
DTC Logic .....	47	<b>B1084 PRE-TEN FRONT RH</b> .....	74
Diagnosis Procedure .....	48	Description .....	74
<b>B1051, B1056 DRIVER AIRBAG MODULE</b> .....	50	DTC Logic .....	74
Description .....	50	Diagnosis Procedure .....	75
DTC Logic .....	50	<b>B1086 PRE-TEN FRONT LH</b> .....	76
Diagnosis Procedure .....	51	Description .....	76
<b>B1052, B1057 DRIVER AIRBAG MODULE</b> .....	53	DTC Logic .....	76
Description .....	53	Diagnosis Procedure .....	77
DTC Logic .....	53	<b>B1087 PRE-TEN FRONT LH</b> .....	78
Diagnosis Procedure .....	54	Description .....	78
<b>B1058, B1059, B1060, B1061, B1062, B1063 DIAGNOSIS SENSOR UNIT</b> .....	56	DTC Logic .....	78
Description .....	56	Diagnosis Procedure .....	79
DTC Logic .....	56	<b>B1088 PRE-TEN FRONT LH</b> .....	80
Diagnosis Procedure .....	57	Description .....	80
<b>B1065, B1070 ASSIST A/B MODULE</b> .....	58	DTC Logic .....	80
Description .....	58	Diagnosis Procedure .....	81
DTC Logic .....	58	<b>B1089 PRE-TEN FRONT LH</b> .....	82
Diagnosis Procedure .....	59	Description .....	82
<b>B1066, B1071 ASSIST A/B MODULE</b> .....	60	DTC Logic .....	82
Description .....	60	Diagnosis Procedure .....	83
DTC Logic .....	60	<b>B1106, B1107, B1108, B1109, B1110, B1111 DIAGNOSIS SENSOR UNIT</b> .....	84
Diagnosis Procedure .....	61	Description .....	84
<b>B1067, B1072 ASSIST A/B MODULE</b> .....	62	DTC Logic .....	84
Description .....	62	Diagnosis Procedure .....	85
DTC Logic .....	62	<b>B1113, B1114 SATELLITE SENS RH</b> .....	86
Diagnosis Procedure .....	63	Description .....	86
<b>B1068, B1073 ASSIST A/B MODULE</b> .....	64	DTC Logic .....	86
Description .....	64	Diagnosis Procedure .....	87
DTC Logic .....	64	<b>B1115, B1116 SATELLITE SENS RH</b> .....	88
Diagnosis Procedure .....	65	Description .....	88
<b>B1074, B1075, B1076, B1077, B1078, B1079 DIAGNOSIS SENSOR UNIT</b> .....	66	DTC Logic .....	88
Description .....	66	Diagnosis Procedure .....	89
<b>B1081 PRE-TEN FRONT RH</b> .....	68	<b>B1118, B1119 SATELLITE SENS LH</b> .....	90
Description .....	68	Description .....	90
DTC Logic .....	68	DTC Logic .....	90
Diagnosis Procedure .....	69		
<b>B1082 PRE-TEN FRONT RH</b> .....	70		
Description .....	70		
DTC Logic .....	70		
Diagnosis Procedure .....	71		
<b>B1083 PRE-TEN FRONT RH</b> .....	72		
Description .....	72		
DTC Logic .....	72		
Diagnosis Procedure .....	73		
<b>B1084 PRE-TEN FRONT RH</b> .....	74		
Description .....	74		
DTC Logic .....	74		
Diagnosis Procedure .....	75		
<b>B1086 PRE-TEN FRONT LH</b> .....	76		
Description .....	76		
DTC Logic .....	76		
Diagnosis Procedure .....	77		
<b>B1087 PRE-TEN FRONT LH</b> .....	78		
Description .....	78		
DTC Logic .....	78		
Diagnosis Procedure .....	79		
<b>B1088 PRE-TEN FRONT LH</b> .....	80		
Description .....	80		
DTC Logic .....	80		
Diagnosis Procedure .....	81		
<b>B1089 PRE-TEN FRONT LH</b> .....	82		
Description .....	82		
DTC Logic .....	82		
Diagnosis Procedure .....	83		
<b>B1106, B1107, B1108, B1109, B1110, B1111 DIAGNOSIS SENSOR UNIT</b> .....	84		
Description .....	84		
DTC Logic .....	84		
Diagnosis Procedure .....	85		
<b>B1113, B1114 SATELLITE SENS RH</b> .....	86		
Description .....	86		
DTC Logic .....	86		
Diagnosis Procedure .....	87		
<b>B1115, B1116 SATELLITE SENS RH</b> .....	88		
Description .....	88		
DTC Logic .....	88		
Diagnosis Procedure .....	89		
<b>B1118, B1119 SATELLITE SENS LH</b> .....	90		
Description .....	90		
DTC Logic .....	90		

Diagnosis Procedure .....	91	Diagnosis Procedure .....	115
<b>B1120, B1121 SATELLITE SENS LH .....</b>	<b>92</b>	<b>B1146 CURTAIN MODULE RH .....</b>	<b>116</b>
Description .....	92	Description .....	116
DTC Logic .....	92	DTC Logic .....	116
Diagnosis Procedure .....	93	Diagnosis Procedure .....	117
<b>B1122, B1123, B1124, B1125, B1126, B1127</b>		<b>B1147 CURTAIN MODULE RH .....</b>	<b>118</b>
<b>DIAGNOSIS SENSOR UNIT .....</b>	<b>94</b>	Description .....	118
Description .....	94	DTC Logic .....	118
DTC Logic .....	94	Diagnosis Procedure .....	119
Diagnosis Procedure .....	95	<b>B1148 CURTAIN MODULE RH .....</b>	<b>120</b>
<b>B1129 SIDE MODULE RH .....</b>	<b>96</b>	Description .....	120
Description .....	96	DTC Logic .....	120
DTC Logic .....	96	Diagnosis Procedure .....	121
Diagnosis Procedure .....	97	<b>B1150 CURTAIN MODULE LH .....</b>	<b>122</b>
<b>B1130 SIDE MODULE RH .....</b>	<b>98</b>	Description .....	122
Description .....	98	DTC Logic .....	122
DTC Logic .....	98	Diagnosis Procedure .....	123
Diagnosis Procedure .....	99	<b>B1151 CURTAIN MODULE LH .....</b>	<b>124</b>
<b>B1131 SIDE MODULE RH .....</b>	<b>100</b>	Description .....	124
Description .....	100	DTC Logic .....	124
DTC Logic .....	100	Diagnosis Procedure .....	125
Diagnosis Procedure .....	101	<b>B1152 CURTAIN MODULE LH .....</b>	<b>126</b>
<b>B1132 SIDE MODULE RH .....</b>	<b>102</b>	Description .....	126
Description .....	102	DTC Logic .....	126
DTC Logic .....	102	Diagnosis Procedure .....	127
Diagnosis Procedure .....	103	<b>B1153 CURTAIN MODULE LH .....</b>	<b>128</b>
<b>B1134 SIDE MODULE LH .....</b>	<b>104</b>	Description .....	128
Description .....	104	DTC Logic .....	128
DTC Logic .....	104	Diagnosis Procedure .....	129
Diagnosis Procedure .....	105	<b>B1170, B1171, B1172, B1173, B1174, B1175</b>	
<b>B1135 SIDE MODULE LH .....</b>	<b>106</b>	<b>DIAGNOSIS SENSOR UNIT .....</b>	<b>130</b>
Description .....	106	Description .....	130
DTC Logic .....	106	DTC Logic .....	130
Diagnosis Procedure .....	107	Diagnosis Procedure .....	131
<b>B1136 SIDE MODULE LH .....</b>	<b>108</b>	<b>B1177 PRE-TEN2 FRONT RH .....</b>	<b>132</b>
Description .....	108	Description .....	132
DTC Logic .....	108	DTC Logic .....	132
Diagnosis Procedure .....	109	Diagnosis Procedure .....	133
<b>B1137 SIDE MODULE LH .....</b>	<b>110</b>	<b>B1178 PRE-TEN2 FRONT RH .....</b>	<b>134</b>
Description .....	110	Description .....	134
DTC Logic .....	110	DTC Logic .....	134
Diagnosis Procedure .....	111	Diagnosis Procedure .....	135
<b>B1138, B1139, B1140, B1141, B1142, B1143</b>		<b>B1179 PRE-TEN2 FRONT RH .....</b>	<b>136</b>
<b>DIAGNOSIS SENSOR UNIT .....</b>	<b>112</b>	Description .....	136
Description .....	112	DTC Logic .....	136
DTC Logic .....	112	Diagnosis Procedure .....	137
Diagnosis Procedure .....	113	<b>B1180 PRE-TEN2 FRONT RH .....</b>	<b>138</b>
<b>B1145 CURTAIN MODULE RH .....</b>	<b>114</b>	Description .....	138
Description .....	114	DTC Logic .....	138
DTC Logic .....	114	Diagnosis Procedure .....	139

A  
B  
C  
D  
E  
F  
G  
H  
I  
J  
K  
L  
M  
N  
O  
P

SRC

<b>B1182 PRE-TEN2 FRONT LH</b> .....	<b>140</b>	Precaution for Supplemental Restraint System (SRS) "AIR BAG" and "SEAT BELT PRE-TENSIONER" .....	173
Description .....	140	Service .....	173
DTC Logic .....	140	Occupant Classification System Precaution .....	173
Diagnosis Procedure .....	141		
<b>B1183 PRE-TEN2 FRONT LH</b> .....	<b>142</b>		
Description .....	142		
DTC Logic .....	142		
Diagnosis Procedure .....	143		
<b>B1184 PRE-TEN2 FRONT LH</b> .....	<b>144</b>		
Description .....	144		
DTC Logic .....	144		
Diagnosis Procedure .....	145		
<b>B1185 PRE-TEN2 FRONT LH</b> .....	<b>146</b>		
Description .....	146		
DTC Logic .....	146		
Diagnosis Procedure .....	147		
<b>B1202, B1203, B1204, B1205, B1206, B1207 DIAGNOSIS SENSOR UNIT</b> .....	<b>148</b>		
Description .....	148		
DTC Logic .....	148		
Diagnosis Procedure .....	149		
<b>B1209 FRONTAL COLLISION DETECTION</b> .....	<b>150</b>		
Description .....	150		
DTC Logic .....	150		
Diagnosis Procedure .....	150		
<b>B1210 SIDE COLLISION DETECTION</b> .....	<b>152</b>		
Description .....	152		
DTC Logic .....	152		
Diagnosis Procedure .....	152		
<b>ECU DIAGNOSIS INFORMATION</b> .....	<b>154</b>		
<b>DIAGNOSIS SENSOR UNIT</b> .....	<b>154</b>		
DTC Index .....	154		
Wiring Diagram — SRS AIR BAG CONTROL SYSTEM — .....	163		
<b>SYMPTOM DIAGNOSIS</b> .....	<b>170</b>		
<b>SRS AIR BAG WARNING LAMP DOES NOT TURN OFF</b> .....	<b>170</b>		
Diagnosis Procedure .....	170		
<b>SRS AIR BAG WARNING LAMP DOES NOT TURN ON</b> .....	<b>171</b>		
Diagnosis Procedure .....	171		
<b>PASSENGER SEAT BELT WARNING SYSTEM</b> .....	<b>172</b>		
Diagnosis Procedure .....	172		
<b>PRECAUTION</b> .....	<b>173</b>		
<b>PRECAUTIONS</b> .....	<b>173</b>		
		<b>FOR MEXICO</b>	
		<b>BASIC INSPECTION</b> .....	<b>174</b>
		<b>DIAGNOSIS AND REPAIR WORK FLOW</b> .....	<b>174</b>
		Work Flow .....	174
		<b>SYSTEM DESCRIPTION</b> .....	<b>176</b>
		<b>SRS AIR BAG SYSTEM</b> .....	<b>176</b>
		System Diagram .....	176
		System Description .....	176
		Component Parts Location .....	177
		Component Description .....	178
		<b>DIAGNOSIS SYSTEM (AIRBAG)</b> .....	<b>179</b>
		Diagnosis Description .....	179
		CONSULT-III Function .....	181
		<b>DTC/CIRCUIT DIAGNOSIS</b> .....	<b>183</b>
		<b>B1001, B1002, B1003, B1004, B1005 DIAGNOSIS SENSOR UNIT</b> .....	<b>183</b>
		Description .....	183
		DTC Logic .....	183
		Diagnosis Procedure .....	184
		<b>B1006, B1007, B1008, B1009, B1010 DIAGNOSIS SENSOR UNIT</b> .....	<b>185</b>
		Description .....	185
		DTC Logic .....	185
		Diagnosis Procedure .....	186
		<b>B1011, B1012, B1013, B1014, B1015 DIAGNOSIS SENSOR UNIT</b> .....	<b>187</b>
		Description .....	187
		DTC Logic .....	187
		Diagnosis Procedure .....	188
		<b>B1026, B1027, B1028, B1029, B1030, B1031 DIAGNOSIS SENSOR UNIT</b> .....	<b>189</b>
		Description .....	189
		DTC Logic .....	189
		Diagnosis Procedure .....	190
		<b>B1033, B1034 CRASH ZONE SEN</b> .....	<b>191</b>
		Description .....	191
		DTC Logic .....	191
		Diagnosis Procedure .....	192
		<b>B1035, B1036, B1038, B1040 CRASH ZONE SEN</b> .....	<b>193</b>
		Description .....	193
		DTC Logic .....	193
		Diagnosis Procedure .....	194

<b>B1042, B1043, B1044, B1045, B1046, B1047</b>	Diagnosis Procedure .....	218	
<b>DIAGNOSIS SENSOR UNIT .....</b>	<b>B1082 PRE-TEN FRONT RH .....</b>	<b>219</b>	A
Description .....	Description .....	219	
DTC Logic .....	DTC Logic .....	219	B
Diagnosis Procedure .....	Diagnosis Procedure .....	220	
<b>B1049 DRIVER AIRBAG MODULE .....</b>	<b>B1083 PRE-TEN FRONT RH .....</b>	<b>221</b>	C
Description .....	Description .....	221	
DTC Logic .....	DTC Logic .....	221	
Diagnosis Procedure .....	Diagnosis Procedure .....	222	
<b>B1050 DRIVER AIRBAG MODULE .....</b>	<b>B1084 PRE-TEN FRONT RH .....</b>	<b>223</b>	D
Description .....	Description .....	223	
DTC Logic .....	DTC Logic .....	223	
Diagnosis Procedure .....	Diagnosis Procedure .....	224	E
<b>B1051 DRIVER AIRBAG MODULE .....</b>	<b>B1086 PRE-TEN FRONT LH .....</b>	<b>225</b>	
Description .....	Description .....	225	F
DTC Logic .....	DTC Logic .....	225	
Diagnosis Procedure .....	Diagnosis Procedure .....	226	
<b>B1052 DRIVER AIRBAG MODULE .....</b>	<b>B1087 PRE-TEN FRONT LH .....</b>	<b>227</b>	G
Description .....	Description .....	227	
DTC Logic .....	DTC Logic .....	227	
Diagnosis Procedure .....	Diagnosis Procedure .....	228	
<b>B1058, B1059, B1060, B1061, B1062, B1063</b>	<b>B1088 PRE-TEN FRONT LH .....</b>	<b>229</b>	SRC
<b>DIAGNOSIS SENSOR UNIT .....</b>	Description .....	229	
Description .....	DTC Logic .....	229	I
DTC Logic .....	Diagnosis Procedure .....	230	
Diagnosis Procedure .....	<b>B1089 PRE-TEN FRONT LH .....</b>	<b>231</b>	J
<b>B1065 ASSIST A/B MODULE .....</b>	Description .....	231	
Description .....	DTC Logic .....	231	
DTC Logic .....	Diagnosis Procedure .....	232	
Diagnosis Procedure .....	<b>B1106, B1107, B1108, B1109, B1110, B1111</b>		K
<b>B1066 ASSIST A/B MODULE .....</b>	<b>DIAGNOSIS SENSOR UNIT .....</b>	<b>233</b>	
Description .....	Description .....	233	L
DTC Logic .....	DTC Logic .....	233	
Diagnosis Procedure .....	Diagnosis Procedure .....	234	
<b>B1067 ASSIST A/B MODULE .....</b>	<b>B1113, B1114 SATELLITE SENS RH .....</b>	<b>235</b>	M
Description .....	Description .....	235	
DTC Logic .....	DTC Logic .....	235	
Diagnosis Procedure .....	Diagnosis Procedure .....	236	N
<b>B1068 ASSIST A/B MODULE .....</b>	<b>B1115, B1116 SATELLITE SENS RH .....</b>	<b>237</b>	
Description .....	Description .....	237	O
DTC Logic .....	DTC Logic .....	237	
Diagnosis Procedure .....	Diagnosis Procedure .....	238	
<b>B1074, B1075, B1076, B1077, B1078, B1079</b>	<b>B1118, B1119 SATELLITE SENS LH .....</b>	<b>239</b>	P
<b>DIAGNOSIS SENSOR UNIT .....</b>	Description .....	239	
Description .....	DTC Logic .....	239	
DTC Logic .....	Diagnosis Procedure .....	240	
Diagnosis Procedure .....	<b>B1120, B1121 SATELLITE SENS LH .....</b>	<b>241</b>	
<b>B1081 PRE-TEN FRONT RH .....</b>	Description .....	241	
Description .....	DTC Logic .....	241	
DTC Logic .....	Diagnosis Procedure .....	242	

<b>B1122, B1123, B1124, B1125, B1126, B1127</b>	<b>B1147 CURTAIN MODULE RH</b>	<b>267</b>
<b>DIAGNOSIS SENSOR UNIT</b>	Description	267
Description	DTC Logic	267
DTC Logic	Diagnosis Procedure	268
Diagnosis Procedure		
<b>B1129 SIDE MODULE RH</b>	<b>B1148 CURTAIN MODULE RH</b>	<b>269</b>
Description	Description	269
DTC Logic	DTC Logic	269
Diagnosis Procedure	Diagnosis Procedure	270
<b>B1130 SIDE MODULE RH</b>	<b>B1150 CURTAIN MODULE LH</b>	<b>271</b>
Description	Description	271
DTC Logic	DTC Logic	271
Diagnosis Procedure	Diagnosis Procedure	272
<b>B1131 SIDE MODULE RH</b>	<b>B1151 CURTAIN MODULE LH</b>	<b>273</b>
Description	Description	273
DTC Logic	DTC Logic	273
Diagnosis Procedure	Diagnosis Procedure	274
<b>B1132 SIDE MODULE RH</b>	<b>B1152 CURTAIN MODULE LH</b>	<b>275</b>
Description	Description	275
DTC Logic	DTC Logic	275
Diagnosis Procedure	Diagnosis Procedure	276
<b>B1134 SIDE MODULE LH</b>	<b>B1153 CURTAIN MODULE LH</b>	<b>277</b>
Description	Description	277
DTC Logic	DTC Logic	277
Diagnosis Procedure	Diagnosis Procedure	278
<b>B1135 SIDE MODULE LH</b>	<b>B1170, B1171, B1172, B1173, B1174, B1175</b>	
Description	<b>DIAGNOSIS SENSOR UNIT</b>	<b>279</b>
DTC Logic	Description	279
Diagnosis Procedure	DTC Logic	279
	Diagnosis Procedure	280
<b>B1136 SIDE MODULE LH</b>	<b>B1177 PRE-TEN2 FRONT RH</b>	<b>281</b>
Description	Description	281
DTC Logic	DTC Logic	281
Diagnosis Procedure	Diagnosis Procedure	282
<b>B1137 SIDE MODULE LH</b>	<b>B1178 PRE-TEN2 FRONT RH</b>	<b>283</b>
Description	Description	283
DTC Logic	DTC Logic	283
Diagnosis Procedure	Diagnosis Procedure	284
<b>B1138, B1139, B1140, B1141, B1142, B1143</b>	<b>B1179 PRE-TEN2 FRONT RH</b>	<b>285</b>
<b>DIAGNOSIS SENSOR UNIT</b>	Description	285
Description	DTC Logic	285
DTC Logic	Diagnosis Procedure	286
Diagnosis Procedure		
<b>B1145 CURTAIN MODULE RH</b>	<b>B1180 PRE-TEN2 FRONT RH</b>	<b>287</b>
Description	Description	287
DTC Logic	DTC Logic	287
Diagnosis Procedure	Diagnosis Procedure	288
<b>B1146 CURTAIN MODULE RH</b>	<b>B1182 PRE-TEN2 FRONT LH</b>	<b>289</b>
Description	Description	289
DTC Logic	DTC Logic	289
Diagnosis Procedure	Diagnosis Procedure	290
	<b>B1183 PRE-TEN2 FRONT LH</b>	<b>291</b>

Description .....	291	DTC Logic .....	301	
DTC Logic .....	291	Diagnosis Procedure .....	301	A
Diagnosis Procedure .....	292			
<b>B1184 PRE-TEN2 FRONT LH .....</b>	<b>293</b>	<b>ECU DIAGNOSIS INFORMATION .....</b>	<b>303</b>	
Description .....	293	<b>DIAGNOSIS SENSOR UNIT .....</b>	<b>303</b>	B
DTC Logic .....	293	DTC Index .....	303	
Diagnosis Procedure .....	294	Wiring Diagram — SRS AIR BAG CONTROL SYSTEM — .....	311	C
<b>B1185 PRE-TEN2 FRONT LH .....</b>	<b>295</b>	<b>SYMPTOM DIAGNOSIS .....</b>	<b>316</b>	
Description .....	295	<b>SRS AIR BAG WARNING LAMP DOES NOT TURN OFF .....</b>	<b>316</b>	D
DTC Logic .....	295	Diagnosis Procedure .....	316	
Diagnosis Procedure .....	296	<b>SRS AIR BAG WARNING LAMP DOES NOT TURN ON .....</b>	<b>317</b>	E
<b>B1202, B1203, B1204, B1205, B1206, B1207</b>		Diagnosis Procedure .....	317	F
<b>DIAGNOSIS SENSOR UNIT .....</b>	<b>297</b>	<b>PRECAUTION .....</b>	<b>318</b>	
Description .....	297	<b>PRECAUTIONS .....</b>	<b>318</b>	G
DTC Logic .....	297	Precaution for Supplemental Restraint System (SRS) "AIR BAG" and "SEAT BELT PRE-TENSIONER" .....	318	
Diagnosis Procedure .....	298	Service .....	318	SRC
<b>B1209 FRONTAL COLLISION DETECTION ..</b>	<b>299</b>			
Description .....	299			I
DTC Logic .....	299			J
Diagnosis Procedure .....	299			K
<b>B1210 SIDE COLLISION DETECTION .....</b>	<b>301</b>			L
Description .....	301			M
				N
				O
				P

# DIAGNOSIS AND REPAIR WORK FLOW

< BASIC INSPECTION >

[FOR USA AND CANADA]

## BASIC INSPECTION

### DIAGNOSIS AND REPAIR WORK FLOW

Work Flow

INFOID:000000005252625

#### OVERALL SEQUENCE

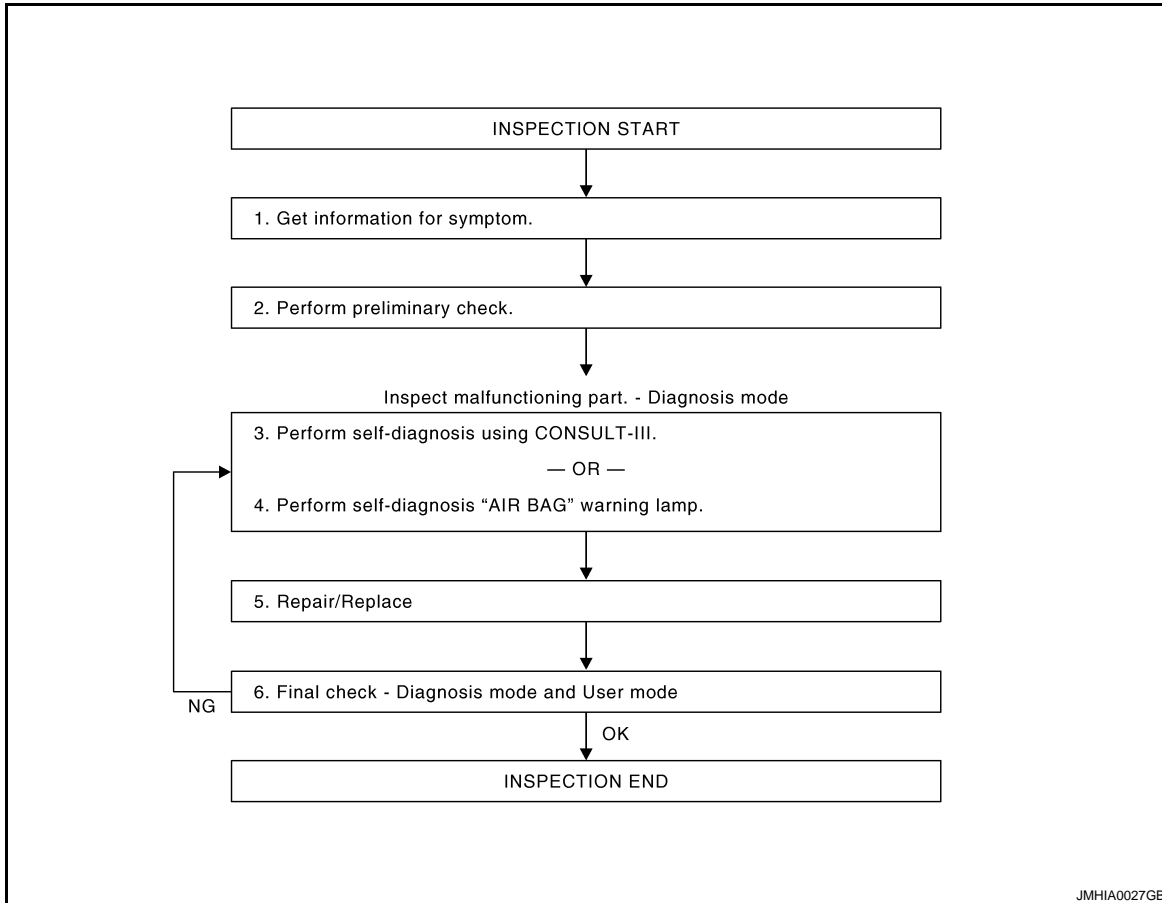

#### DETAILED FLOW

##### 1.GET INFORMATION FOR SYMPTOM

Interview the customer about the symptom.

>> GO TO 2.

##### 2.PERFORM PRELIMINARY CHECK

At the beginning of inspection, confirm the condition of power supply circuit, check that the battery is charged and fuses and fusible links are not blown.

Is power supply circuit normal?

YES-1 >> GO TO 3. (With CONSULT-III)

YES-2 >> GO TO 4. (Without CONSULT-III)

NO >> Repair or replace the battery and fuse/fusible links.

##### 3.PERFORM SELF-DIAGNOSIS USING "CONSULT-III" (WITH CONSULT-III)

Perform "AIR BAG" Self Diagnostic Result.

Is "MALFUNCTIONING PART" displayed on CONSULT-III?

YES >> GO TO 5.

NO >> Repeat DTC confirmation with diagnostic procedure.



# DIAGNOSIS AND REPAIR WORK FLOW

< BASIC INSPECTION >

[FOR USA AND CANADA]

---

## 4.PERFORM SELF-DIAGNOSIS "AIR BAG" WARNING LAMP (WITHOUT CONSULT-III)

---

Check the air bag warning lamp status.

Is "MALFUNCTIONING PART" detected?

YES >> GO TO 5.

NO >> Repeat DTC confirmation with diagnostic procedure.

---

## 5.REPAIR OR REPLACE

---

Repair or replace the malfunctioning part.

After the malfunction is repaired, erase the self-diagnostic result. Refer to [SRC-18. "Diagnosis Description"](#) or [SRC-20. "CONSULT-III Function"](#).

>> GO TO 6.

---

## 6.FINAL CHECK

---

Perform "AIR BAG" Self Diagnostic Result with CONSULT-III and /or, air bag warning lamp status.

Are all malfunctions corrected?

YES >> **INSPECTION END**

NO-1 >> GO TO 3. (With CONSULT-III)

NO-2 >> GO TO 4. (Without CONSULT-III)

A  
B  
C  
D  
E  
F  
G  
I  
J  
K  
L  
M  
N  
O  
P

SRC

SYSTEM DESCRIPTION

SRS AIR BAG SYSTEM

System Diagram

INFOID:000000005252626

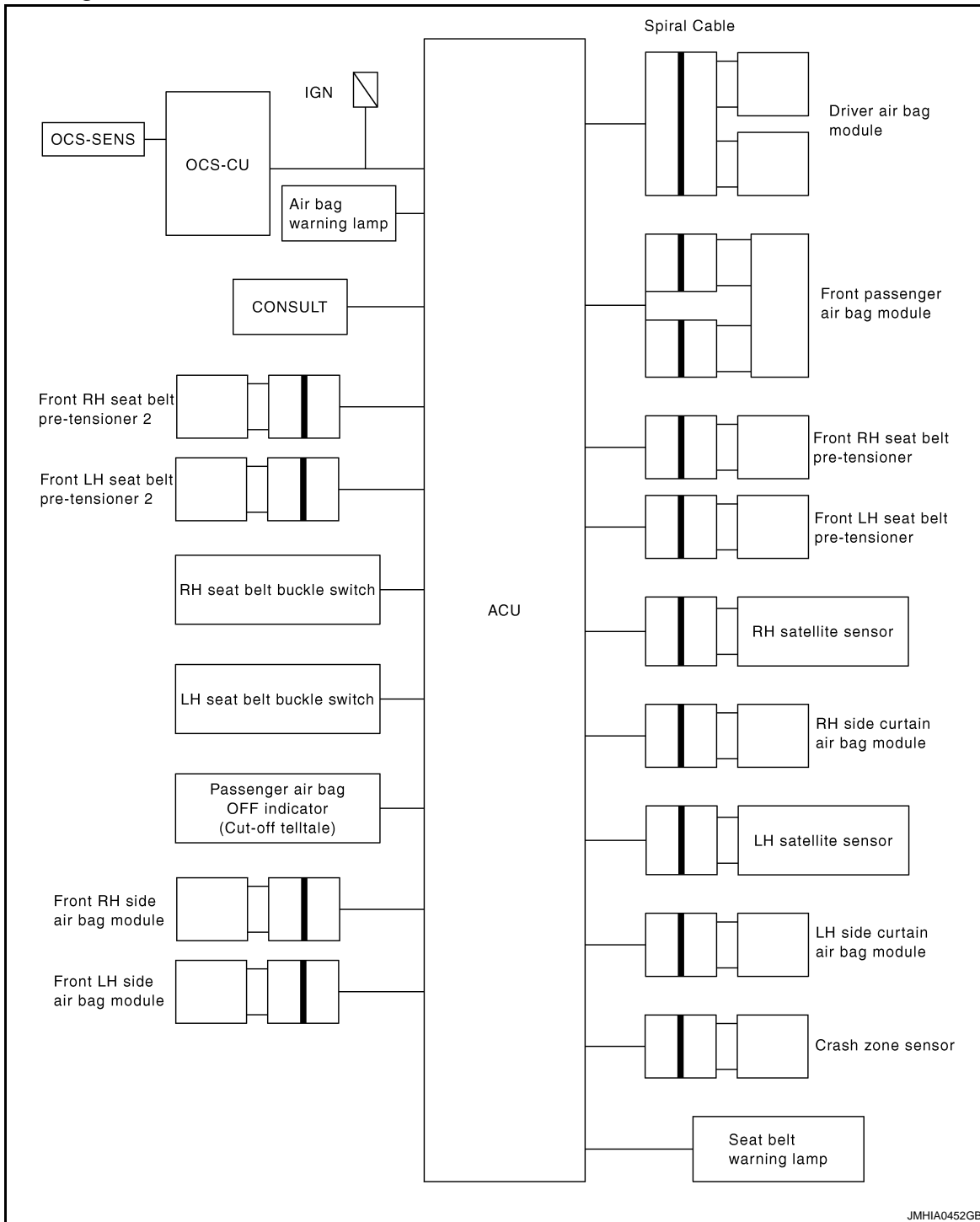

System Description

INFOID:000000005252627

This SRS Air Bag System has the following function.

1. Detects crash and supplies the energy for deploying air bag and seat belt pre-tensioner.
2. Detects electrical trouble in air bag system and seat belt pre-tensioner system, records trouble code, and blinking Air bag warning lamp.

# SRS AIR BAG SYSTEM

[FOR USA AND CANADA]

## < SYSTEM DESCRIPTION >

3. Detects and records the deployment of air bag and seat belt pre-tensioner, and turns on air bag warning lamp.
4. Indicates malfunctioning portion with blinking times of air bag warning lamp in diagnosis mode.
5. Indicate the malfunctioning record by CONSULT-III.
6. Suppress the deployment of passenger air bag when the passenger seat is empty or when occupied by turns on passenger air bag off indicator (cut-off telltale) when passenger seat is occupied with a child-seat and child. [Occupant Classification System (OCS).]
7. Turn on Seat belt warning lamp when the Occupant Classification System (OCS) option is adult or child and the passenger seat belt buckle switch is not on.

## Component Parts Location

INFOID:000000005252628

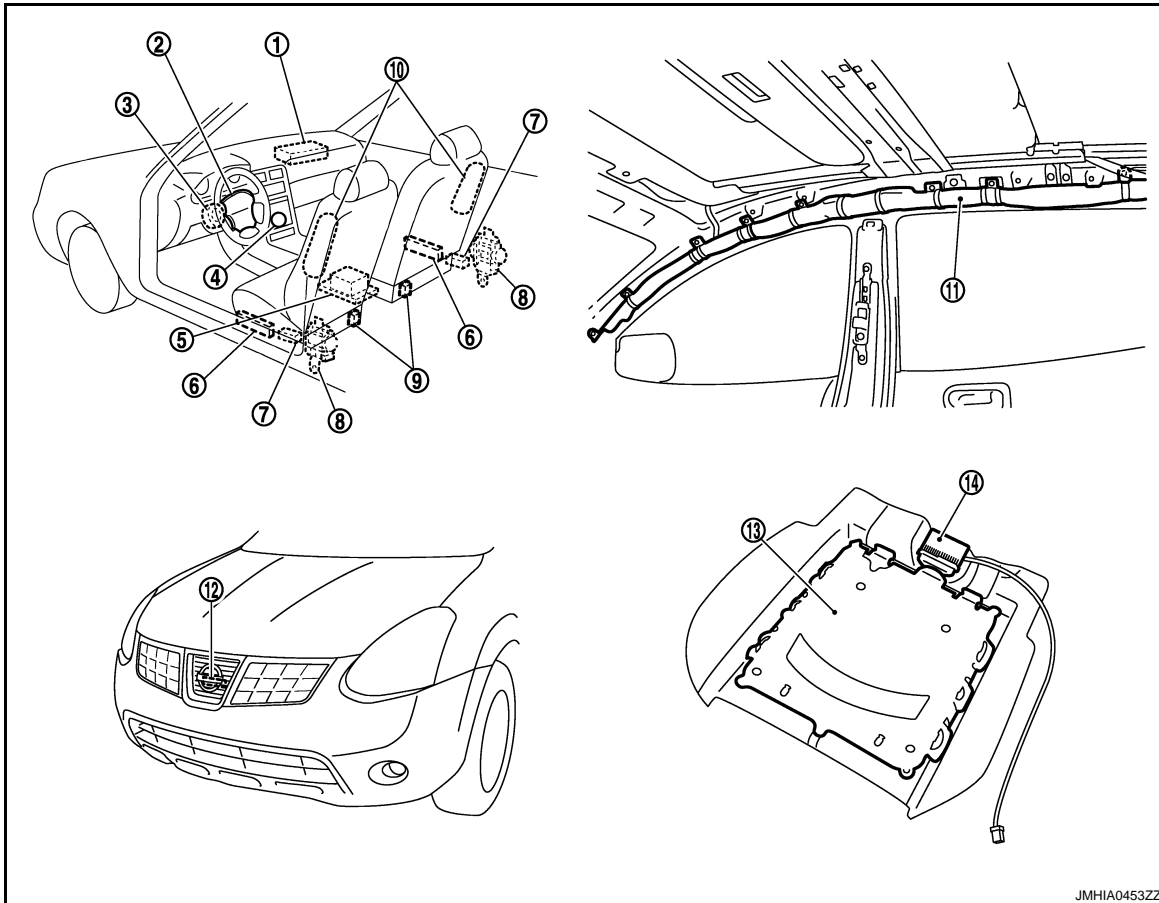

- |   |  |   |
|---|--|---|
| 1. Front passenger air bag module M62                       | 2. Driver air bag module M350, M351                            | 3. Combination switch (spiral cable) M32                                  |
| 4. Passenger air bag off indicator (Cut-off telltale) M44   | 5. Air bag diagnosis sensor unit (ACU) B13, B14, M59           | 6. Front LH/RH seat belt pre-tensioner 2<br>• LH B31<br>• RH B42          |
| 7. LH/RH Air bag (satellite) sensor<br>• LH B37<br>• RH B30 | 8. Front LH/RH seat belt pre-tensioner<br>• LH B35<br>• RH B28 | 9. Seat belt buckle switch<br>• Driver side B409<br>• Passenger side B416 |
| 10. Front LH/RH side air bag module<br>• LH B16<br>• RH B18 | 11. LH/RH side curtain air bag module<br>• LH B72<br>• RH B56  | 12. Crash zone sensor E33   |
| 13. OCS seat sensor mat                                     | 14. OCS control unit B39                                       |   |

# SRS AIR BAG SYSTEM

< SYSTEM DESCRIPTION >

[FOR USA AND CANADA]

## Component Description

INFOID:000000005252629

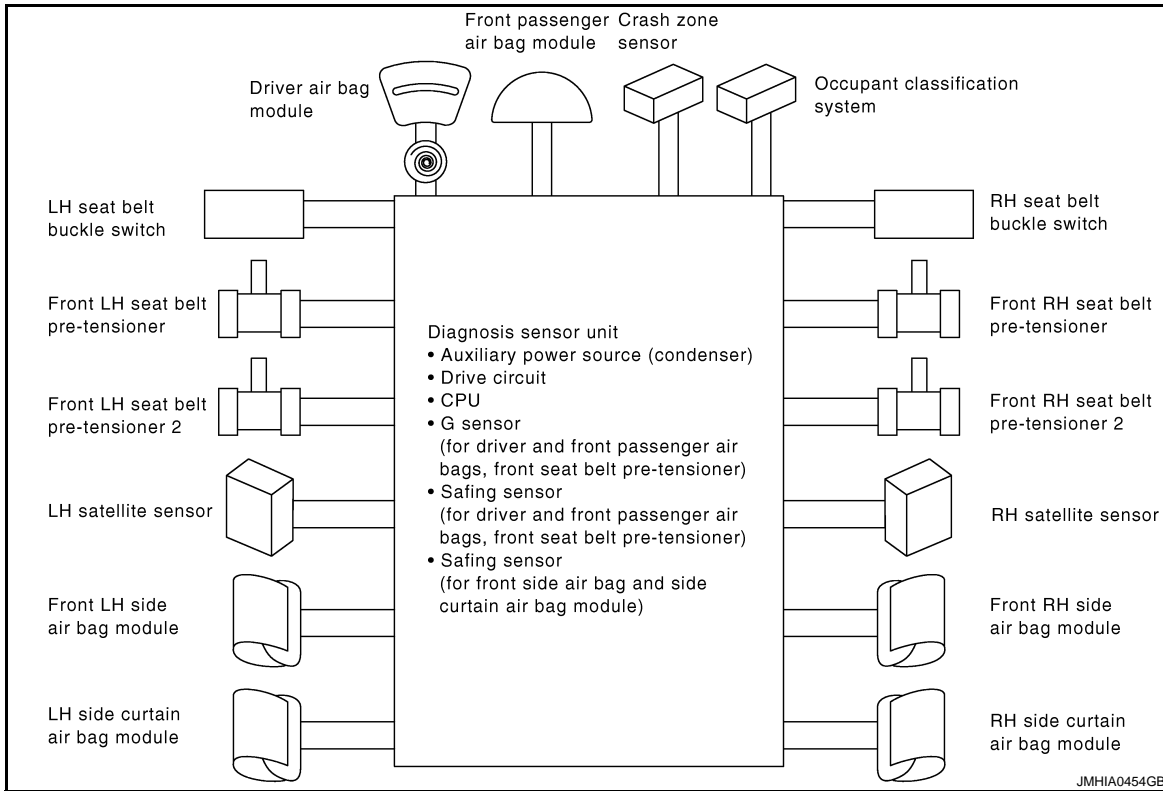

- Air bag sensor are prepared for operation while the ignition switch is in the ON or START position.
- The operation of supplemental restraint system is different from collision modes applications. For example, the driver air bag module and front passenger air bag module are activated in a frontal collision but not in a side collision.
- SRS configurations which are activated for some collision modes are as follows.

SRS configuration	Frontal collision	Left side collision	Right side collision
Driver air bag module.	×	—	—
Front passenger air bag module.	×	—	—
Front LH seat belt pre-tensioner.	×	—	—
Front RH seat belt pre-tensioner.	×	—	—
Front LH seat belt pre-tensioner 2.	×	—	—
Front RH seat belt pre-tensioner 2.	×	—	—
Front LH side air bag module.	—	×	—
Front RH side air bag module.	—	—	×
LH side curtain air bag module.	—	×	—
RH side curtain air bag module.	—	—	×

×: Application, —: Not application

# OCCUPANT CLASSIFICATION SYSTEM

< SYSTEM DESCRIPTION >

[FOR USA AND CANADA]

## OCCUPANT CLASSIFICATION SYSTEM

### System Diagram

INFOID:000000005252630

### OCCUPANT CLASSIFICATION SYSTEM

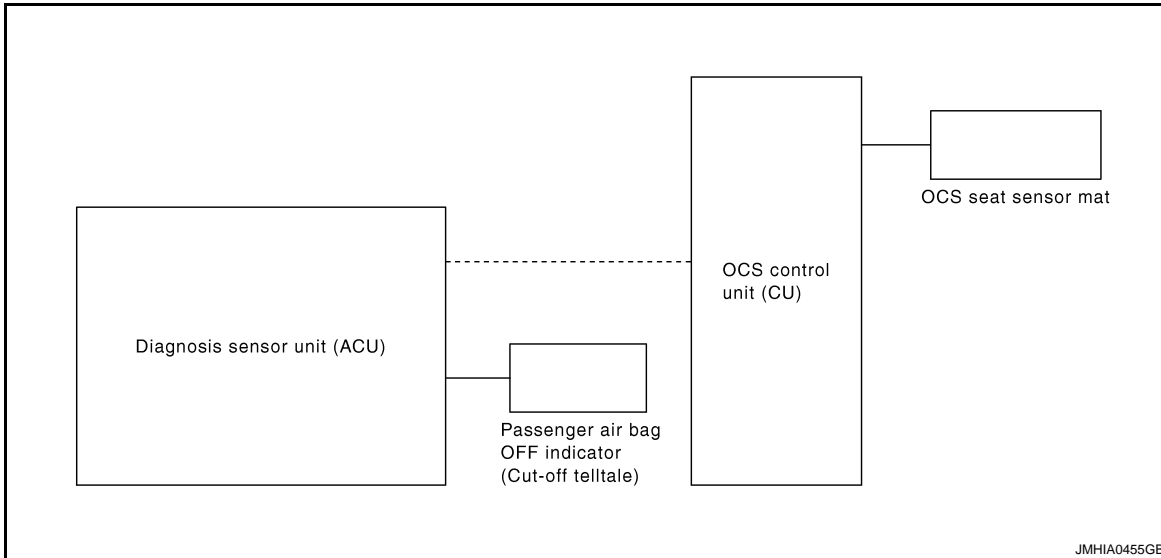

### System Description

INFOID:000000005252631

This Occupant Classification System has the following function.

1. Suppresses the deployment of passenger air bag when passenger seat is empty, or when occupied by child and child-seat. Turns on passenger air bag off indicator (cut-off telltale) when passenger seat is occupied by child-seat and child. [Occupant Classification System (OCS).]
2. Indicates malfunction portion with blinking times of air bag warning lamp in diagnosis mode.
3. Indicates the malfunctioning record by CONSULT-III.

**NOTE:**

Operation of ACU when ACU receives information from Occupant Classification System (OCS)

Status (Front passenger seat)	Passenger Air bag	Passenger Air bag off indicator (Cut-off telltale)	Air bag warning lamp	Seat belt warning lamp (when front passenger seat is unbuckled)
Empty	Suppress	Off	Off	Off
Child/ child-seat	Suppress	On	Off	On
Adult	Enable to deploy	Off	Off	On
Trouble	Suppress	On	Blinking	Off

### Component Parts Location

INFOID:000000005252632

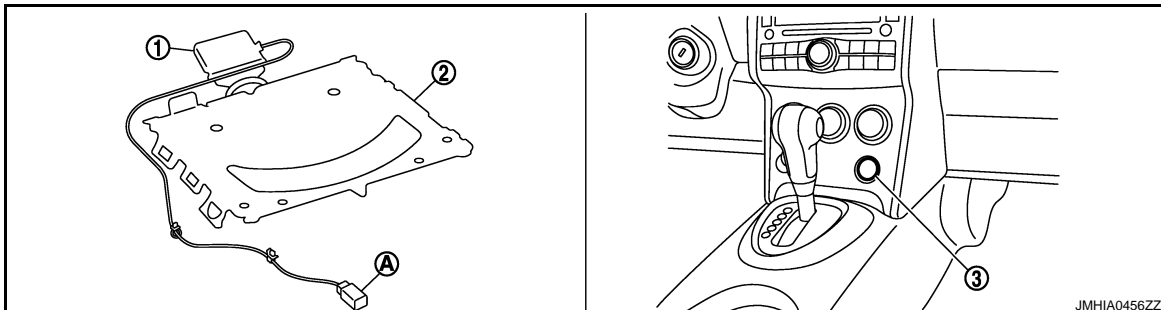

# OCCUPANT CLASSIFICATION SYSTEM

[FOR USA AND CANADA]

< SYSTEM DESCRIPTION >

1. OCS control unit B39
  2. OCS seat sensor mat
  3. Passenger air bag OFF indicator (cut-off telltale) M44
- A. OCS harness connector

## Component Description

INFOID:000000005252633

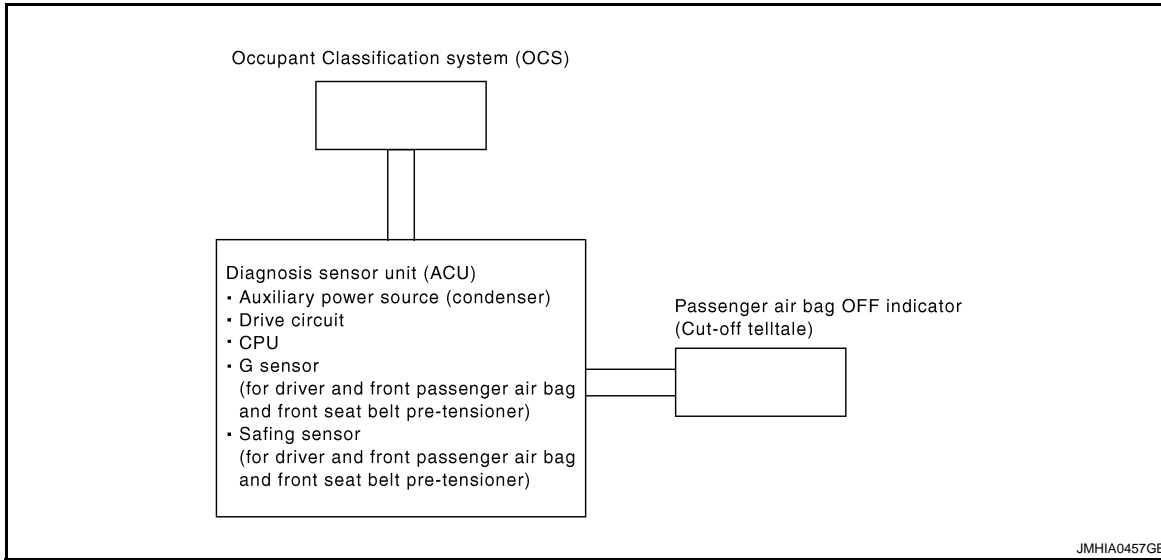

## Component Parts

- OCS control unit, Seat sensor mat. Refer to [SRC-32, "Description"](#).
- Passenger air bag OFF indicator (cut-off telltale). Refer to [SRC-34, "Description"](#).

# PASSENGER SEAT BELT WARNING SYSTEM

< SYSTEM DESCRIPTION >

[FOR USA AND CANADA]

## PASSENGER SEAT BELT WARNING SYSTEM

### System Diagram

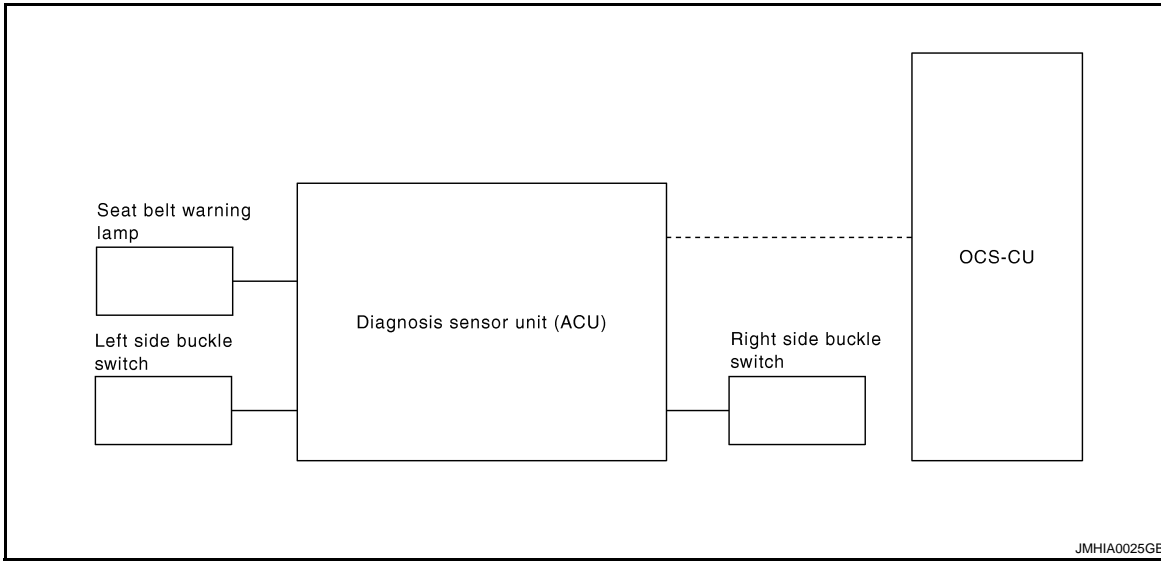

### System Description

INFOID:000000005252635

This Passenger Seat Belt Warning System has the following function.

Turns ON seat belt warning lamp (1), when the OCS judges adult or child in the passenger seat and the passenger seat belt buckle switch is not on.

**NOTE:**

In addition, a seat belt warning lamp illuminates and a seat belt alarm sounds, when the driver seat belt buckle switch is not on, This does not relate to the air bag sensor. (Refer to BCM.)

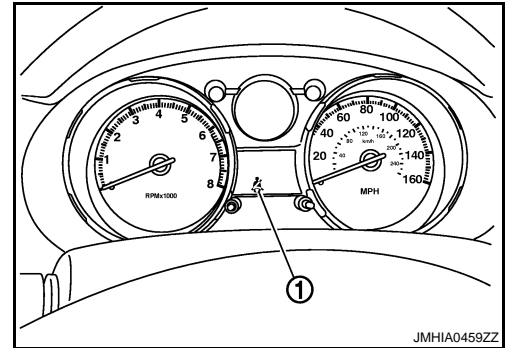

**NOTE:**

Operation of ACU when ACU receives information from Occupant Classification System (OCS)

Status (Front passenger seat)	Passenger Air bag	Passenger air bag off indicator (cut-off telltale)	Air bag warning lamp	Seat belt warning lamp (When front passenger seat is unbuckled)
Empty	Suppress	Off	Off	Off
Child/ child-seat	Suppress	On	Off	On
Adult	Enable to deploy	Off	Off	On
Trouble	Suppress	On	Blinking	Off

# PASSENGER SEAT BELT WARNING SYSTEM

< SYSTEM DESCRIPTION >

[FOR USA AND CANADA]

## Component Parts Location

INFOID:000000005252636

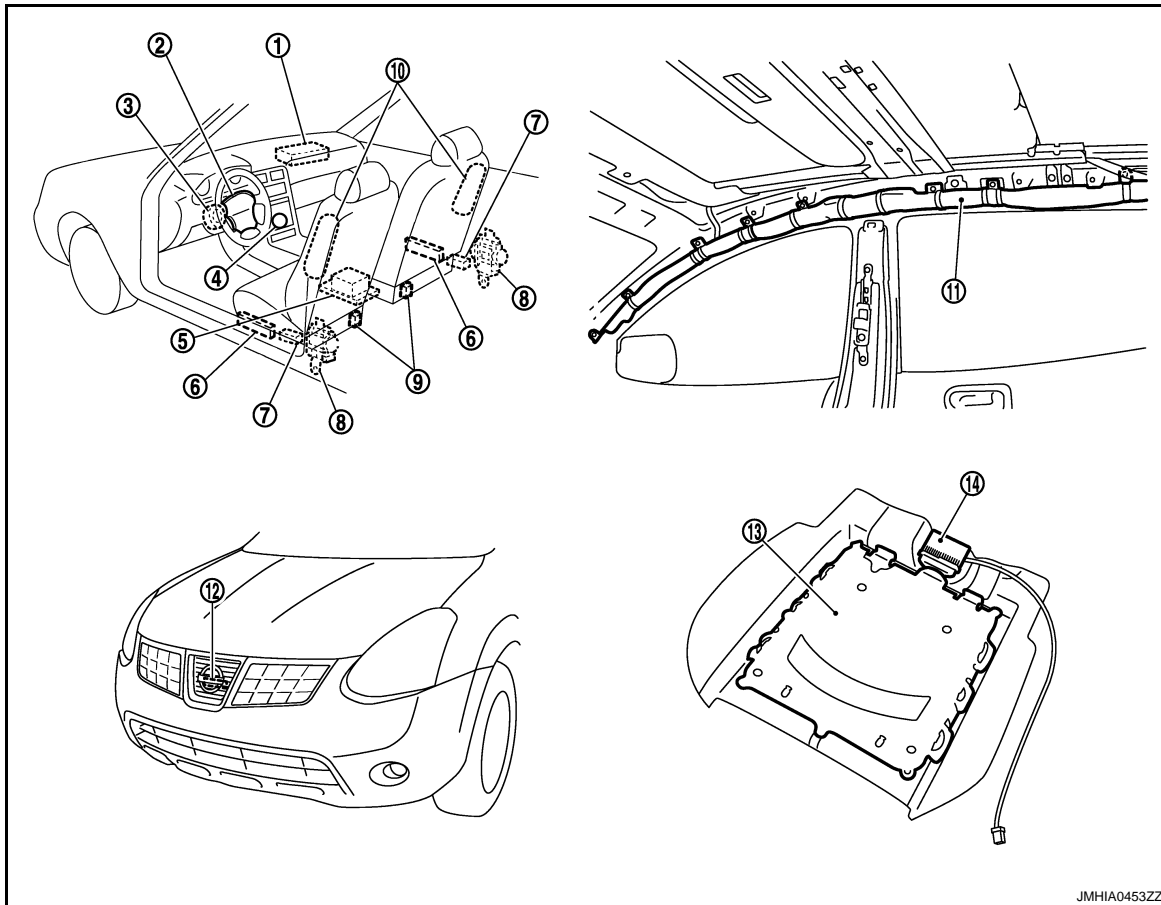

JMHIA0453ZZ

- |   |  |  |
|---|--|--|
| 1. Front passenger air bag module M62                     | 2. Driver air bag module M350, M351                  | 3. Combination switch (spiral cable) M32 |
| 4. Passenger air bag off indicator (Cut-off telltale) M44 | 5. Air bag diagnosis sensor unit (ACU) B13, B14, M59 | 6. Front LH/RH seat belt pre-tensioner 2 |
| 7. LH/RH Air bag (satellite) sensor                       | 8. Front LH/RH seat belt pre-tensioner               | 9. Seat belt buckle switch               |
| • LH B37  | • LH B35   | • Driver side B409                       |
| • RH B30  | • RH B28   | • Passenger side B416                    |
| 10. Front LH/RH side air bag module                       | 11. LH/RH side curtain air bag module                | 12. Crash zone sensor E33                |
| • LH B16  | • LH B72   |  |
| • RH B18  | • RH B56   |  |
| 13. OCS seat sensor mat                                   | 14. OCS control unit B39                             |  |



# PASSENGER SEAT BELT WARNING SYSTEM

< SYSTEM DESCRIPTION >

[FOR USA AND CANADA]

## Component Description

INFOID:000000005252637

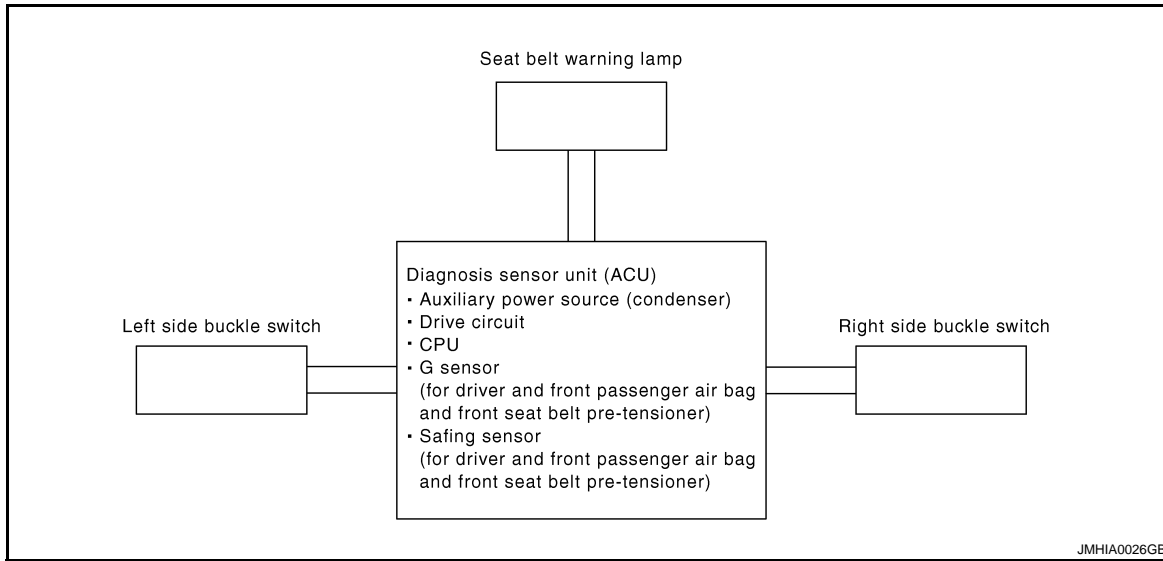

### Component parts

- Seat belt warning lamp (1).
- Seat belt buckle switch.

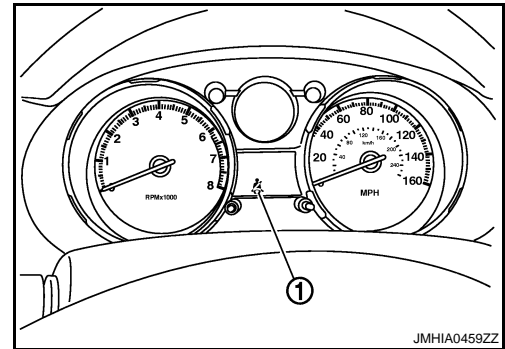

A  
B  
C  
D  
E  
F  
G  
I  
J  
K  
L  
M  
N  
O  
P

SRC

## DIAGNOSIS SYSTEM (AIRBAG)

### Diagnosis Description

INFOID:000000005252638

**CAUTION:**

- Do not use electrical test equipment on any circuit related to the SRS unless instructed in this Service Manual. SRS wiring harnesses can be identified by yellow and/or orange harnesses or harness connectors.
- Do not repair, splice or modify the SRS wiring harness. If the harness is damaged, replace it with a new one.
- Keep ground portion clean.

### DIAGNOSIS FUNCTION

- The SRS self-diagnosis results can be read by using “AIR BAG” warning lamp and/or CONSULT-III.
- The user mode is exclusively prepared for the customer (driver). This mode warns the driver of a system malfunction through the operation of the “AIR BAG” warning lamp.
- The Diagnosis mode allows the technician to locate and inspect the malfunctioning part.
- The mode applications for the “AIR BAG” warning lamp and CONSULT-III are as follows.

	User mode	Diagnosis mode	Display type
“AIR BAG” warning lamp	X	X	ON-OFF operation
CONSULT-III	–	X	Monitoring

### HOW TO PERFORM TROUBLE DIAGNOSIS FOR QUICK AND ACCURATE REPAIR

A good understanding of the malfunction conditions can make troubleshooting faster and more accurate. In general, each customer feels differently about a malfunction. It is important to fully understand the symptoms or conditions for a customer complaint.

Information from Customer.

- WHAT..... Vehicle model.
- WHEN..... Date, Frequencies.
- WHERE..... Road conditions.
- HOW..... Operating conditions, Symptoms.

Preliminary Check.

Check that the following parts are in good order.

- Battery (Refer to [PG-3, "How to Handle Battery"](#)).
- Fuse (Refer to [SRC-163, "Wiring Diagram — SRS AIR BAG CONTROL SYSTEM —"](#)).
- System component-to-harness connections.

### HOW TO ERASE SELF-DIAGNOSTIC RESULTS (With CONSULT-III)

- “SELF-DIAG [CURRENT]”  
A current self-diagnosis result is displayed on CONSULT-III screen in real time. After the malfunction is repaired completely, no malfunction is detected on “SELF-DIAG [CURRENT]”.
- “SELF-DIAG [PAST]”  
Return to “SELF-DIAG [CURRENT]” CONSULT-III screen by touching “BACK” key of CONSULT-III and select “SELF-DIAG [CURRENT]” in SELECT DIAG MODE. Touch “ERASE” in “SELF-DIAG [CURRENT]” mode.  
**NOTE:**  
If the memory of the malfunction in “SELF-DIAG [PAST]” is not erased, the user mode shows the system malfunction by the operation of the warning lamp even if the malfunction is repaired completely.
- “TROUBLE DIAG RECORD”  
The memory of “TROUBLE DIAG RECORD” cannot be erased.

### HOW TO ERASE SELF-DIAGNOSTIC RESULTS (Without CONSULT-III)

After a malfunction is repaired, turn the ignition switch OFF for at least one second, then turn ignition switch ON diagnosis mode returns to the user mode. At that time the self-diagnosis result is cleared.

# DIAGNOSIS SYSTEM (AIRBAG)

[FOR USA AND CANADA]

< SYSTEM DESCRIPTION >

## DIAGNOSTIC PROCEDURE (User mode)

Checking Air bag operation according to "AIR BAG" Warning Lamp-User Mode

1. Turn the ignition switch from OFF to ON, and check that the air bag warning lamp blinks.
2. Compare the SRS air bag warning lamp blinking pattern with the examples.

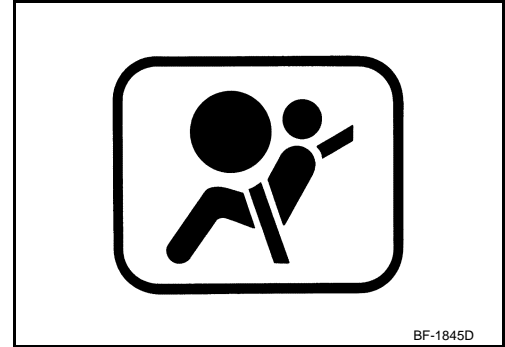

Warning lamp examples (User mode)

"AIR BAG" warning lamp operation -User mode	SRS condition	Reference item
<p>SHIA0011E</p>	<ul style="list-style-type: none"> <li>• No malfunction is detected.</li> <li>• No further action is necessary.</li> </ul>	<p>—</p>
<p>SHIA0012E</p>	<ul style="list-style-type: none"> <li>• The system is malfunctioning and needs to be repaired as indicated.</li> </ul>	<p>Go to <a href="#">SRC-18, "Diagnosis Description"</a>.</p>

A  
B  
C  
D  
E  
F  
G  
H  
I  
J  
K  
L  
M  
N  
O  
P

SRC

# DIAGNOSIS SYSTEM (AIRBAG)

< SYSTEM DESCRIPTION >

[FOR USA AND CANADA]

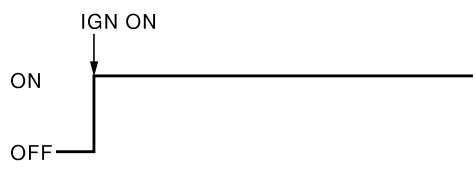
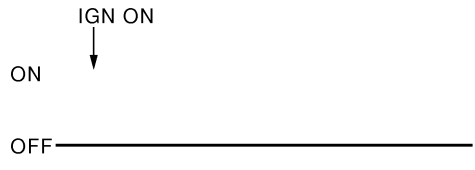
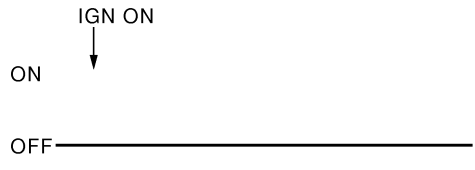
"AIR BAG" warning lamp operation -User mode	SRS condition	Reference item
 <p style="text-align: right;">SHIA0013E</p>	<ul style="list-style-type: none"> <li>Air bag is deployed.</li> <li>Seat belt pre-tensioner is deployed.</li> </ul>	Go to <a href="#">SRC-150, "Diagnosis Procedure"</a> or <a href="#">SRC-152, "Diagnosis Procedure"</a> .
 <p style="text-align: right;">SHIA0014E</p>	<ul style="list-style-type: none"> <li>Diagnosis sensor unit is malfunctioning.</li> <li>Air bag power supply circuit is malfunctioning.</li> <li>SRS air bag warning lamp circuit is malfunctioning.</li> </ul>	Go to <a href="#">SRC-170, "Diagnosis Procedure"</a> .
 <p style="text-align: right;">SHIA0014E</p>	<ul style="list-style-type: none"> <li>Diagnosis sensor unit is malfunctioning.</li> <li>Air bag warning lamp circuit is malfunctioning.</li> </ul>	Go to <a href="#">SRC-170, "Diagnosis Procedure"</a> .

## DIAGNOSTIC PROCEDURE (With CONSULT-III)

Diagnostic Mode	Description
SELF-DIAG RESULT	The self-diagnosis result is displayed. (SELF-DIAG [CURRENT], [PAST], [RECORD])
ECU DISCRIMINATED No.	The part number of diagnosis sensor unit is displayed.

## CONSULT-III Function

INFOID:000000005252639

### DIAGNOSIS MODE FOR CONSULT-III

- "SELF-DIAG [CURRENT]"  
A current self-diagnosis results (also indicated with the number of warning lamp blinks in diagnosis mode) are displayed on CONSULT-III screen in real time. This refers to a malfunctioning part requiring repairs.
- "SELF-DIAG [PAST]"  
Diagnosis results previously stored in the memory are displayed on CONSULT-III screen. The stored results are not erased until memory erasing is executed.
- "TROUBLE DIAG RECORD"  
With TROUBLE DIAG RECORD, diagnosis results previously erased by a reset operation can be displayed on CONSULT-III screen.
- "ECU DISCRIMINATED NO."  
Air bag diagnosis sensor unit ECU discriminated number (identification number) is displayed. Air bag diagnosis sensor unit has individual ECU discriminated number (identification number) based on model and equipment.

### HOW TO CHANGE SELF-DIAGNOSIS MODE WITH CONSULT-III

#### From User Mode to Diagnosis Mode

After selecting "AIR BAG" on the "SELECT SYSTEM" screen, User mode automatically changes to Diagnosis mode.

#### From Diagnosis Mode to User Mode

To return to User mode from Diagnosis mode, touch "BACK" key of CONSULT-III until "SELECT SYSTEM" appears, then diagnosis mode automatically changes to User mode.

# DIAGNOSIS SYSTEM (AIRBAG)

< SYSTEM DESCRIPTION >

[FOR USA AND CANADA]

## SELF-DIAGNOSIS FUNCTION (Without CONSULT-III)

- The reading of these results is accomplished by “User mode” and “Diagnosis mode”.
- After a malfunction is repaired, turn ignition switch ON. Diagnosis mode returns to the user mode. At that time, the self-diagnosis result is cleared.

## HOW TO CHANGE SELF-DIAGNOSIS MODE WITHOUT CONSULT-III

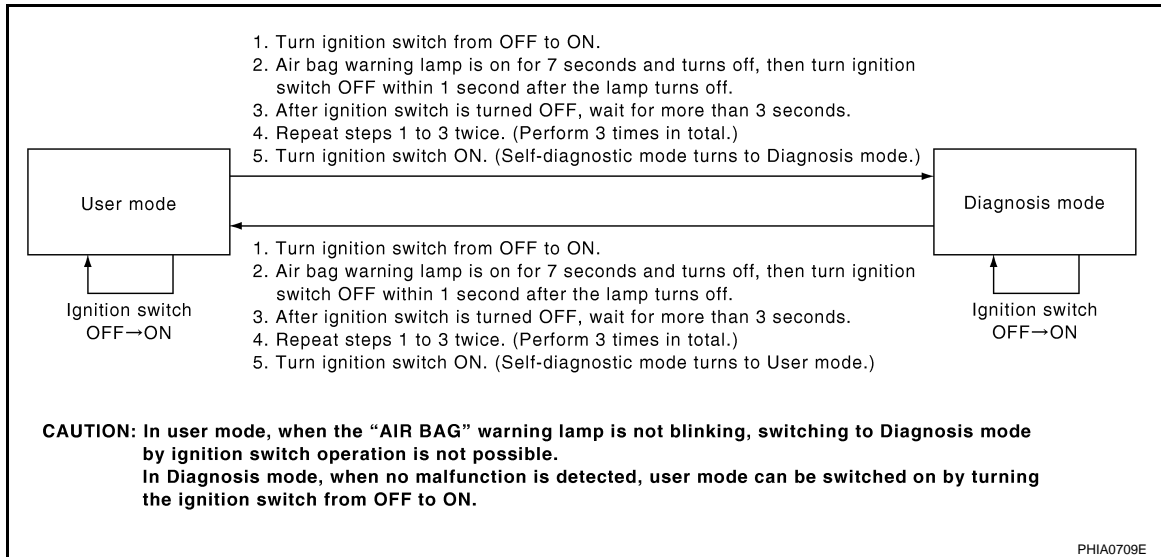

A  
B  
C  
D  
E  
F  
G  
I  
J  
K  
L  
M  
N  
O  
P

SRC

# B1001, B1002, B1003, B1004, B1005 DIAGNOSIS SENSOR UNIT

< DTC/CIRCUIT DIAGNOSIS >

[FOR USA AND CANADA]

## DTC/CIRCUIT DIAGNOSIS

### B1001, B1002, B1003, B1004, B1005 DIAGNOSIS SENSOR UNIT

#### Description

INFOID:000000005252640

#### DTC B1001, B1002, B1003, B1004, B1005 DIAGNOSIS SENSOR UNIT

Detects the whole SRS electrical system and displays the malfunction either by illuminating or blinking the air bag warning lamp in the combination meter. Malfunctioning part can be detected by on board self-diagnosis system and electro-diagnosis tester CONSULT-III.

#### OPERATION

It detects a shock that exceeds specified level and monitors such systems as the driver and passenger air bag, side air bag, curtain air bag, pre-tensioner seat belts and Occupant Classification System (OCS) operate properly.

#### STRUCTURE

It contains the "G" sensors for both frontal and side collisions and spare battery function in case of main battery damage in collision.

#### INSTALLATION

SRS diagnosis sensor unit is installed under the center console with fixed bolts.

#### DTC Logic

INFOID:000000005252641

#### DTC DETECTION LOGIC

With CONSULT-III

DTC No. Index ("SELF-DIAG [CURRENT]"), ("SELF-DIAG [PAST]" or "TROUBLE DIAG RECORD")

DTC No.	Trouble diagnosis name	DTC detecting condition	Possible cause
B1001 B1002 B1003 B1004 B1005	CONTROL UNIT	Diagnosis sensor unit is out of order.	Internal breakdown in diagnosis sensor unit (ACU).

#### DTC CONFIRMATION PROCEDURE (With CONSULT-III)

##### 1.INSPECTION START

Turn ignition switch ON.

>> GO TO 2.

##### 2.CHECK SELF-DIAG RESULT

Check the screen of CONSULT-III.

Is malfunctioning part detected?

- YES >> Refer to [SRC-23. "Diagnosis Procedure"](#).
- NO >> **INSPECTION END.**

#### DTC CONFIRMATION PROCEDURE (Without CONSULT-III)

##### NOTE:

- SRS will not enter diagnosis mode if no malfunction is detected in user mode.

##### 1.INSPECTION START

# B1001, B1002, B1003, B1004, B1005 DIAGNOSIS SENSOR UNIT

< DTC/CIRCUIT DIAGNOSIS >

[FOR USA AND CANADA]

Turn ignition switch ON.

>> GO TO 2.

## 2.CHECK AIR BAG WARNING LAMP

Check the warning lamp status.

Is malfunctioning part detected?

- YES >> Refer to [SRC-154, "DTC Index"](#).  
NO >> **INSPECTION END.**

## Diagnosis Procedure

INFOID:000000005252642

With CONSULT-III

### **WARNING:**

- Before servicing, turn ignition switch OFF, disconnect both battery terminals and wait at least 3 minutes. (To discharge backup capacitor.)
- Do not use unspecified tester or other measuring device.

## DIAGNOSTIC PROCEDURE

### 1.CHECK HARNESS CONNECTOR

Check the connection of harness connector.

Is the inspection result normal?

- YES >> GO TO 2.  
NO >> Repair or replace harness connectors.

### 2.CHECK WIRING HARNESS

Check the wiring harness externals.

Is the inspection result normal?

- YES >> GO TO 3.  
NO >> Repair or replace wiring harness.

### 3.CHECK DIAGNOSIS SENSOR UNIT

1. Replace diagnosis sensor unit (ACU).
2. Check the screen of CONSULT-III.

Is the inspection result normal?

- YES >> **INSPECTION END.**  
NO >> Check the intermittent incident. Refer to [GI-40, "Intermittent Incident"](#).

A  
B  
C  
D  
E  
F  
G  
I  
J  
K  
L  
M  
N  
O  
P

SRC

# B1006, B1007, B1008, B1009, B1010 DIAGNOSIS SENSOR UNIT

< DTC/CIRCUIT DIAGNOSIS >

[FOR USA AND CANADA]

## B1006, B1007, B1008, B1009, B1010 DIAGNOSIS SENSOR UNIT

### Description

INFOID:000000005252643

#### DTC B1006, B1007, B1008, B1009, B1010 DIAGNOSIS SENSOR UNIT

Detects the whole SRS electrical system and displays the malfunction either by illuminating or blinking the air bag warning lamp in the combination meter. Malfunctioning part can be detected by on board self-diagnosis system and electro-diagnosis tester CONSULT-III.

### OPERATION

It detects a shock that exceeds specified level and monitors such systems as the driver and passenger air bag, side air bag, curtain air bag, pre-tensioner seat belts and Occupant Classification System (OCS) operate properly.

### STRUCTURE

It contains the "G" sensors for both frontal and side collisions and spare battery function in case of main battery damage in collision.

### INSTALLATION

SRS diagnosis sensor unit is installed under the center console with fixed bolts.

### DTC Logic

INFOID:000000005252644

### DTC DETECTION LOGIC

With CONSULT-III

DTC No. Index ("SELF-DIAG [CURRENT]"), ("SELF-DIAG [PAST]" or "TROUBLE DIAG RECORD")

DTC No.	Trouble diagnosis name	DTC detecting condition	Possible cause
B1006 B1007 B1008 B1009 B1010	CONTROL UNIT	Diagnosis sensor unit is out of order.	Internal breakdown in diagnosis sensor unit (ACU).

### DTC CONFIRMATION PROCEDURE (With CONSULT-III)

#### 1.INSPECTION START

Turn ignition switch ON.

>> GO TO 2.

#### 2.CHECK SELF-DIAG RESULT

Check the screen of CONSULT-III.

Is malfunctioning part detected?

YES >> Refer to [SRC-25, "Diagnosis Procedure"](#).

NO >> **INSPECTION END.**

### DTC CONFIRMATION PROCEDURE (Without CONSULT-III)

#### NOTE:

- SRS will not enter diagnosis mode if no malfunction is detected in user mode.

#### 1.INSPECTION START

Turn ignition switch ON.



# B1006, B1007, B1008, B1009, B1010 DIAGNOSIS SENSOR UNIT

< DTC/CIRCUIT DIAGNOSIS >

[FOR USA AND CANADA]

>> GO TO 2.

## 2.CHECK AIR BAG WARNING LAMP

Check the warning lamp status.

Is malfunctioning part detected?

YES >> Refer to [SRC-154, "DTC Index"](#).

NO >> **INSPECTION END.**

## Diagnosis Procedure

INFOID:000000005252645

With CONSULT-III

### **WARNING:**

- Before servicing, turn ignition switch OFF, disconnect both battery terminals and wait at least 3 minutes. (To discharge backup capacitor.)
- Do not use unspecified tester or other measuring device.

## DIAGNOSTIC PROCEDURE

### 1.CHECK HARNESS CONNECTOR

Check the connection of harness connector.

Is the inspection result normal?

YES >> GO TO 2.

NO >> Repair or replace harness connectors.

### 2.CHECK WIRING HARNESS

Check the wiring harness externals.

Is the inspection result normal?

YES >> GO TO 3.

NO >> Repair or replace wiring harness.

### 3.CHECK DIAGNOSIS SENSOR UNIT

1. Replace diagnosis sensor unit (ACU).

2. Check the screen of CONSULT-III.

Is the inspection result normal?

YES >> **INSPECTION END.**

NO >> Check the intermittent incident. Refer to [GI-40, "Intermittent Incident"](#).

A  
B  
C  
D  
E  
F  
G  
SRC  
I  
J  
K  
L  
M  
N  
O  
P

# B1011, B1012, B1013, B1014, B1015 DIAGNOSIS SENSOR UNIT

< DTC/CIRCUIT DIAGNOSIS >

[FOR USA AND CANADA]

## B1011, B1012, B1013, B1014, B1015 DIAGNOSIS SENSOR UNIT

### Description

INFOID:000000005252646

#### DTC B1011, B1012, B1013, B1014, B1015 DIAGNOSIS SENSOR UNIT

Detects the whole SRS electrical system and displays the malfunction either by illuminating or blinking the air bag warning lamp in the combination meter. Malfunctioning part can be detected by on board self-diagnosis system and electro-diagnosis tester CONSULT-III.

### OPERATION

It detects a shock that exceeds specified level and monitors such systems as the driver and passenger air bag, side air bag, curtain air bag, pre-tensioner seat belts and Occupant Classification System (OCS) operate properly.

### STRUCTURE

It contains the "G" sensors for both frontal and side collisions and spare battery function in case of main battery damage in collision.

### INSTALLATION

SRS diagnosis sensor unit is installed under the center console with fixed bolts.

### DTC Logic

INFOID:000000005252647

#### DTC DETECTION LOGIC

With CONSULT-III

DTC No. Index ("SELF-DIAG [CURRENT]"), ("SELF-DIAG [PAST]" or "TROUBLE DIAG RECORD")

DTC No.	Trouble diagnosis name	DTC detecting condition	Possible cause
B1011 B1012 B1013 B1014 B1015	CONTROL UNIT	Diagnosis sensor unit is out of order.	Internal breakdown in diagnosis sensor unit (ACU).

#### DTC CONFIRMATION PROCEDURE (With CONSULT-III)

##### 1.INSPECTION START

Turn ignition switch ON.

>> GO TO 2.

##### 2.CHECK SELF-DIAG RESULT

Check the screen of CONSULT-III.

Is malfunctioning part detected?

YES >> Refer to [SRC-27, "Diagnosis Procedure"](#).

NO >> **INSPECTION END.**

#### DTC CONFIRMATION PROCEDURE (Without CONSULT-III)

##### NOTE:

- SRS will not enter diagnosis mode if no malfunction is detected in user mode.

##### 1.INSPECTION START

Turn ignition switch ON.

# B1011, B1012, B1013, B1014, B1015 DIAGNOSIS SENSOR UNIT

< DTC/CIRCUIT DIAGNOSIS >

[FOR USA AND CANADA]

>> GO TO 2.

## 2.CHECK AIR BAG WARNING LAMP

Check the warning lamp status.

Is malfunctioning part detected?

YES >> Refer to [SRC-154, "DTC Index"](#).

NO >> **INSPECTION END.**

## Diagnosis Procedure

INFOID:000000005252648

With CONSULT-III

### **WARNING:**

- Before servicing, turn ignition switch OFF, disconnect both battery terminals and wait at least 3 minutes. (To discharge backup capacitor.)
- Do not use unspecified tester or other measuring device.

## DIAGNOSTIC PROCEDURE

### 1.CHECK HARNESS CONNECTOR

Check the connection of harness connector.

Is the inspection result normal?

YES >> GO TO 2.

NO >> Repair or replace harness connectors.

### 2.CHECK WIRING HARNESS

Check the wiring harness externals.

Is the inspection result normal?

YES >> GO TO 3.

NO >> Repair or replace wiring harness.

### 3.CHECK DIAGNOSIS SENSOR UNIT

1. Replace diagnosis sensor unit (ACU).

2. Check the screen of CONSULT-III.

Is the inspection result normal?

YES >> **INSPECTION END.**

NO >> Check the intermittent incident. Refer to [GI-40, "Intermittent Incident"](#).

A  
B  
C  
D  
E  
F  
G  
I  
J  
K  
L  
M  
N  
O  
P

SRC

# B1017, B1020, B1021 OCCUPANT SENS C/U

< DTC/CIRCUIT DIAGNOSIS >

[FOR USA AND CANADA]

## B1017, B1020, B1021 OCCUPANT SENS C/U

### Description

INFOID:000000005252649

#### DTC B1017, B1020, B1021 [UNIT FAIL] OCCUPANT SENS C/U

Suppresses the deployment of passenger air bag when the condition of passenger seat is empty or child and child-seat. And turns on cut-off telltale lamp when the condition of passenger seat is child-seat and child. In case of malfunction the blinking of the SRS air bag warning lamp report the malfunction to driver and by the on board self-diagnosis system or electro-diagnosis tester CONSULT-III can detect the cause.

### OPERATION

This unit classifies occupant in passenger seat and detects electrical malfunctions in Occupant Classification System, and transmits malfunction information to air bag control unit.

### STRUCTURE

It is integrated into the seat sensor mat and detects the occupants with Occupant Classification System (OCS) control unit that classifies the occupants.

### INSTALLATION

Occupant Classification System (OCS) control unit is installed in the passenger seat cushion.

### DTC Logic

INFOID:000000005252650

### DTC DETECTION LOGIC

With CONSULT-III

DTC No. Index ("SELF-DIAG [CURRENT]"), ("SELF-DIAG [PAST]" or "TROUBLE DIAG RECORD")

DTC No.	Trouble diagnosis name	DTC detecting condition	Possible cause
B1017 B1020 B1021	OCCUPANT SENS C/U [UNIT FAIL]	Trouble occurs in OCS-C/U.	<ul style="list-style-type: none"><li>• Disconnection of wiring harness.</li><li>• Internal breakdown in occupant classification system control unit.</li><li>• Internal breakdown in diagnosis sensor unit (ACU).</li></ul>

### DTC CONFIRMATION PROCEDURE (With CONSULT-III)

#### 1.INSPECTION START

Turn ignition switch ON.

>> GO TO 2.

#### 2.CHECK SELF-DIAG RESULT

Check the screen of CONSULT-III.

Is malfunctioning part detected?

- YES >> Refer to [SRC-29, "Diagnosis Procedure"](#).  
NO >> **INSPECTION END.**

### DTC CONFIRMATION PROCEDURE (Without CONSULT-III)

#### NOTE:

- SRS will not enter diagnosis mode if no malfunction is detected in user mode.

#### 1.INSPECTION START

Turn ignition switch ON.

# B1017, B1020, B1021 OCCUPANT SENS C/U

< DTC/CIRCUIT DIAGNOSIS >

[FOR USA AND CANADA]

>> GO TO 2.

## 2.CHECK AIR BAG WARNING LAMP

Check the warning lamp status.

Is malfunctioning part detected?

YES >> Refer to [SRC-154, "DTC Index"](#).

NO >> **INSPECTION END.**

## Diagnosis Procedure

INFOID:000000005252651

With CONSULTIII

### **WARNING:**

- Before servicing, turn ignition switch OFF, disconnect both battery terminals and wait at least 3 minutes. (To discharge backup capacitor.)
- Do not use unspecified tester or other measuring device.

## DIAGNOSTIC PROCEDURE

### 1.CHECK HARNESS CONNECTOR

Check the connection of harness connector.

Is the inspection result normal?

YES >> GO TO 2.

NO >> Repair or replace harness connectors.

### 2.CHECK WIRING HARNESS

Check the wiring harness externals.

Is the inspection result normal?

YES >> GO TO 3.

NO >> Repair or replace wiring harness.

### 3.CHECK OCCUPANT CLASSIFICATION SYSTEM CONTROL UNIT

1. Replace occupant classification system control unit. (passenger side seat cushion assembly.)
2. Check the screen of CONSULT-III.

is the inspection result normal?

YES >> **INSPECTION END.**

NO >> Check the intermittent incident. Refer to [GI-40, "Intermittent Incident"](#).

A  
B  
C  
D  
E  
F  
G  
I  
J  
K  
L  
M  
N  
O  
P

SRC

## B1018 OCCUPANT SENS

### Description

INFOID:000000005252652

#### DTC B1018 [UNIT FAIL] OCCUPANT SENS

Suppresses the deployment of passenger air bag when the condition of passenger seat is empty or child and child-seat. And turns on cut-off telltale lamp when the condition of passenger seat is child-seat and child. In case of malfunction the blinking of the SRS air bag warning lamp reports the malfunction to driver and by the on board self-diagnosis system or electro-diagnosis tester CONSULT-III can detect the cause.

### OPERATION

The unit classifies occupant in passenger seat and transmits it to Occupant Classification System (OCS) control unit.

### STRUCTURE

Plural sensors are installed in the sensor mat to prevent incorrect sensing induced by the sitting position.

### INSTALLATION

Seat sensor mat is installed in the passenger seat cushion.

### DTC Logic

INFOID:000000005252653

#### DTC DETECTION LOGIC

With CONSULT-III

DTC No. Index (“SELF-DIAG [CURRENT]”), (“SELF-DIAG [PAST]” or “TROUBLE DIAG RECORD”)

DTC No.	Trouble diagnosis name	DTC detecting condition	Possible cause
B1018	OCCUPANT SENS [UNIT FAIL]	Trouble occurs in OCS-SENS.	<ul style="list-style-type: none"> <li>Disconnection of wiring harness.</li> <li>Internal breakdown in occupant classification system sensor.</li> <li>Internal breakdown in diagnosis sensor unit (ACU).</li> </ul>

#### DTC CONFIRMATION PROCEDURE (With CONSULT-III)

##### 1.INSPECTION START

Turn ignition switch ON.

>> GO TO 2.

##### 2.CHECK SELF-DIAG RESULT

Check the screen of CONSULT-III.

Is malfunctioning part detected?

YES >> Refer to [SRC-31. "Diagnosis Procedure"](#).

NO >> **INSPECTION END.**

#### DTC CONFIRMATION PROCEDURE (Without CONSULT-III)

##### NOTE:

- SRS will not enter diagnosis mode if no malfunction is detected in user mode.

##### 1.INSPECTION START

Turn ignition switch ON.

>> GO TO 2.

# B1018 OCCUPANT SENS

[FOR USA AND CANADA]

< DTC/CIRCUIT DIAGNOSIS >

## 2.CHECK AIR BAG WARNING LAMP

Check the warning lamp status.

Is malfunctioning part detected?

- YES >> Refer to [SRC-154, "DTC Index"](#).  
NO >> **INSPECTION END.**

### Diagnosis Procedure

INFOID:000000005252654

With CONSULT-III

#### **WARNING:**

- Before servicing, turn ignition switch OFF, disconnect both battery terminals and wait at least 3 minutes. (To discharge backup capacitor.)
- Do not use unspecified tester or other measuring device.

### DIAGNOSTIC PROCEDURE

#### 1.CHECK HARNESS CONNECTOR

Check the connection of harness connector.

Is the inspection result normal?

- YES >> GO TO 2.  
NO >> Repair or replace harness connectors.

#### 2.CHECK WIRING HARNESS

Check the wiring harness externals.

Is the inspection result normal?

- YES >> GO TO 3.  
NO >> Repair or replace wiring harness.

#### 3.CHECK OCCUPANT CLASSIFICATION SYSTEM SENSOR

1. Replace occupant classification system sensor. (passenger side seat cushion assembly.)
2. Check the screen of CONSULT-III.

Is the inspection result normal?

- YES >> **INSPECTION END.**  
NO >> Check the intermittent incident. Refer to [GI-40, "Intermittent Incident"](#).

A  
B  
C  
D  
E  
F  
G  
I  
J  
K  
L  
M  
N  
O  
P

SRC

**B1022 OCCUPANT SENS C/U****Description**

INFOID:000000005252655

**DTC B1022 [COMM FAIL] OCCUPANT SENS C/U**

Suppresses the deployment of passenger air bag when the condition of passenger seat is empty or child and child-seat. And turns on cut-off telltale lamp when the condition of passenger seat is child-seat and child. In case of malfunction the blinking of the SRS air bag warning lamp reports the malfunction to driver and by the on board self-diagnosis system or electro-diagnosis tester CONSULT-III can detect the cause.

**OPERATION**

This unit classifies occupant in passenger seat and detects electrical malfunction in Occupant Classification System (OCS) and transmits malfunction information to air bag control unit.

**STRUCTURE**

It is integrated into the seat sensor mat and detects the occupants and Occupant Classification System (OCS) control unit that classifies the occupants.

**INSTALLATION**

Occupant Classification System (OCS) control unit is installed in the passenger seat cushion.

**DTC Logic**

INFOID:000000005252656

**DTC DETECTION LOGIC**

With CONSULT-III

DTC No. Index ("SELF-DIAG [CURRENT]"), ("SELF-DIAG [PAST]" or "TROUBLE DIAG RECORD")

DTC No.	Trouble diagnosis name	DTC detecting condition	Possible cause
B1022	OCCUPANT SENS C/U [COMM FAIL]	Trouble occurs in OCS-C/U, circuit of OCS-C/U-ACU or ACU.	<ul style="list-style-type: none"> <li>• Disconnection of wiring harness.</li> <li>• Internal breakdown in occupant classification system control unit.</li> <li>• Internal breakdown in diagnosis sensor unit (ACU).</li> </ul>

**DTC CONFIRMATION PROCEDURE (With CONSULT-III)****1.INSPECTION START**

Turn ignition switch ON.

>> GO TO 2.

**2.CHECK SELF-DIAG RESULT**

Check the screen of CONSULT-III.

Is malfunctioning part detected?

YES >> Refer to [SRC-33, "Diagnosis Procedure"](#).

NO >> **INSPECTION END.**

**DTC CONFIRMATION PROCEDURE (Without CONSULT-III)****NOTE:**

- SRS will not enter diagnosis mode if no malfunction is detected in user mode.

**1.INSPECTION START**

Turn ignition switch ON.



< DTC/CIRCUIT DIAGNOSIS >

>> GO TO 2.

## 2.CHECK AIR BAG WARNING LAMP

Check the warning lamp status.

Is malfunctioning part detected?

YES >> Refer to [SRC-154, "DTC Index"](#).

NO >> **INSPECTION END.**

### Diagnosis Procedure

INFOID:000000005252657

With CONSULT-III

#### **WARNING:**

- Before servicing, turn ignition switch OFF, disconnect both battery terminals and wait at least 3 minutes. (To discharge backup capacitor.)
- Do not use unspecified tester or other measuring device.

### DIAGNOSTIC PROCEDURE

## 1.CHECK HARNESS CONNECTOR

Check the connection of harness connector.

Is the inspection result normal?

YES >> GO TO 2.

NO >> Repair or replace harness connectors.

## 2.CHECK WIRING HARNESS

Check the wiring harness externals.

Is the inspection result normal?

YES >> GO TO 3.

NO >> Repair or replace wiring harness.

## 3.CHECK OCCUPANT CLASSIFICATION SYSTEM CONTROL UNIT

1. Replace occupant classification system control unit. (passenger side seat cushion assembly.)
2. Check the screen of CONSULT-III.

Is the inspection result normal?

YES >> **INSPECTION END.**

NO >> Check the intermittent incident. Refer to [GI-40, "Intermittent Incident"](#).

A  
B  
C  
D  
E  
F  
G  
I  
J  
K  
L  
M  
N  
O  
P

SRC

## B1023 PASS A/B INDCTR CKT

### Description

INFOID:000000005252658

#### DTC B1023 PASS A/B INDCTR CKT

Suppresses the deployment of passenger air bag when the condition of passenger seat is empty or child and child-seat. And turns on passenger air bag indicator (cut-off telltale) lamp when the condition of passenger seat is child-seat and child. In case of malfunction the blinking of the SRS air bag warning lamp reports the malfunction to driver and by the on board self-diagnosis system or electro-diagnosis tester CONSULT-III can detect the cause.

### OPERATION

Turns on passenger air bag indicator (cut-off telltale) when the passenger seat is empty or occupied by child-seat and child.

### STRUCTURE

Passenger air bag indicator (cut-off telltale) with LED illumination.

### INSTALLATION

Passenger air bag indicator (cut-off telltale) is installed at the instrument panel center.

### DTC Logic

INFOID:000000005252659

#### DTC DETECTION LOGIC

With CONSULT-III

DTC No. Index (“SELF-DIAG [CURRENT]”), (“SELF-DIAG [PAST]” or “TROUBLE DIAG RECORD”)

DTC No.	Trouble diagnosis name	DTC detecting condition	Possible cause
B1023	PASS A/B INDCTR CKT [UNIT FAIL]	Cut-off telltale circuit is open or shorted to ground or the circuits are shorted each other.	<ul style="list-style-type: none"> <li>• Disconnection of wiring harness.</li> <li>• Internal breakdown in passenger air bag cut-off indicator unit.</li> <li>• Internal breakdown in diagnosis sensor unit (ACU).</li> </ul>

#### DTC CONFIRMATION PROCEDURE (With CONSULT-III)

##### 1.INSPECTION START

Turn ignition switch ON.

>> GO TO 2.

##### 2.CHECK SELF-DIAG RESULT

Check the screen of CONSULT-III.

Is malfunctioning part detected?

YES >> Refer to [SRC-35, "Diagnosis Procedure"](#).

NO >> **INSPECTION END.**

#### DTC CONFIRMATION PROCEDURE (Without CONSULT-III)

##### NOTE:

- SRS will not enter diagnosis mode if no malfunction is detected in user mode.

##### 1.INSPECTION START

Turn ignition switch ON.

# B1023 PASS A/B INDCTR CKT

< DTC/CIRCUIT DIAGNOSIS >

[FOR USA AND CANADA]

>> GO TO 2.

## 2.CHECK AIR BAG WARNING LAMP

Check the warning lamp status.

Is malfunctioning part detected?

YES >> Refer to [SRC-154, "DTC Index"](#).

NO >> **INSPECTION END.**

## Diagnosis Procedure

INFOID:000000005252660

With CONSULT-III

### **WARNING:**

- Before servicing, turn ignition switch OFF, disconnect both battery terminals and wait at least 3 minutes. (To discharge backup capacitor.)
- Do not use unspecified tester or other measuring device.

## DIAGNOSTIC PROCEDURE

### 1.CHECK HARNESS CONNECTOR

Check the connection of harness connector.

Is the inspection result normal?

YES >> GO TO 2.

NO >> Repair or replace harness connectors.

### 2.CHECK WIRING HARNESS

Check the wiring harness externals.

Is the inspection result normal?

YES >> GO TO 3.

NO >> Repair or replace wiring harness.

### 3.CHECK PASSENGER AIR BAG OFF INDICATOR

1. Replace passenger air bag off indicator.

2. Check the screen of CONSULT-III.

Is the inspection result normal?

YES >> **INSPECTION END.**

NO >> Check the intermittent incident. Refer to [GI-40, "Intermittent Incident"](#).

A  
B  
C  
D  
E  
F  
G  
SRC  
I  
J  
K  
L  
M  
N  
O  
P

# B1026, B1027, B1028, B1029, B1030, B1031 DIAGNOSIS SENSOR UNIT

< DTC/CIRCUIT DIAGNOSIS >

[FOR USA AND CANADA]

## B1026, B1027, B1028, B1029, B1030, B1031 DIAGNOSIS SENSOR UNIT

### Description

INFOID:000000005252661

#### DTC B1026, B1027, B1028, B1029, B1030, B1031 DIAGNOSIS SENSOR UNIT

Detects the whole SRS electrical system and displays the malfunction either by illuminating or blinking the air bag warning lamp in the combination meter. Malfunctioning part can be detected by on board self-diagnosis system and electro-diagnosis tester CONSULT-III.

### OPERATION

It detects a shock that exceeds specified level and monitors such systems as the driver and passenger air bag, side air bag, curtain air bag, pre-tensioner seat belts and Occupant Classification System (OCS) to ensure proper operation.

### STRUCTURE

It contains the "G" sensors for both frontal and side collisions and spare battery function in case of main battery damage in collision.

### INSTALLATION

SRS diagnosis sensor unit is installed under the center console with fixed bolts.

### DTC Logic

INFOID:000000005252662

### DTC DETECTION LOGIC

With CONSULT-III

DTC No. Index ("SELF-DIAG [CURRENT]"), ("SELF-DIAG [PAST]" or "TROUBLE DIAG RECORD")

DTC No.	Trouble diagnosis name	DTC detecting condition	Possible cause
B1026 B1027 B1028 B1029 B1030 B1031	CONTROL UNIT	Diagnosis sensor unit is out of order.	Internal breakdown in diagnosis sensor unit (ACU).

### DTC CONFIRMATION PROCEDURE (With CONSULT-III)

#### 1.INSPECTION START

Turn ignition switch ON.

>> GO TO 2.

#### 2.CHECK SELF-DIAG RESULT

Check the screen of CONSULT-III.

Is malfunctioning part detected?

- YES >> Refer to [SRC-37, "Diagnosis Procedure"](#).
- NO >> **INSPECTION END.**

### DTC CONFIRMATION PROCEDURE (Without CONSULT-III)

#### NOTE:

- SRS will not enter diagnosis mode if no malfunction is detected in user mode.

#### 1.INSPECTION START

Turn ignition switch ON.

# B1026, B1027, B1028, B1029, B1030, B1031 DIAGNOSIS SENSOR UNIT

< DTC/CIRCUIT DIAGNOSIS >

[FOR USA AND CANADA]

>> GO TO 2.

## 2.CHECK AIR BAG WARNING LAMP

Check the warning lamp status.

Is malfunctioning part detected?

YES >> Refer to [SRC-154, "DTC Index"](#).

NO >> **INSPECTION END.**

## Diagnosis Procedure

INFOID:000000005252663

With CONSULT-III

### **WARNING:**

- Before servicing, turn ignition switch OFF, disconnect both battery terminals and wait at least 3 minutes. (To discharge backup capacitor.)
- Do not use unspecified tester or other measuring device.

## DIAGNOSTIC PROCEDURE

### 1.CHECK HARNESS CONNECTOR

Check the connection of harness connector.

Is the inspection result normal?

YES >> GO TO 2.

NO >> Repair or replace harness connectors.

### 2.CHECK WIRING HARNESS

Check the wiring harness externals.

Is the inspection result normal?

YES >> GO TO 3.

NO >> Replace wiring harness.

### 3.CHECK DIAGNOSIS SENSOR UNIT

1. Replace diagnosis sensor unit (ACU).

2. Check the screen of CONSULT-III.

Is the inspection result normal?

YES >> **INSPECTION END.**

NO >> Check the intermittent incident. Refer to [GI-40, "Intermittent Incident"](#).

A  
B  
C  
D  
E  
F  
G  
H  
I  
J  
K  
L  
M  
N  
O  
P

SRC

# B1033, B1034 CRASH ZONE SEN

< DTC/CIRCUIT DIAGNOSIS >

[FOR USA AND CANADA]

## B1033, B1034 CRASH ZONE SEN

### Description

INFOID:000000005252664

#### DTC B1033, B1034 [UNIT FAIL] CRASH ZONE SENSOR

Main "G" sensor generates signal voltage, when it detects deceleration beyond the specified level caused by vehicle frontal collision.

### OPERATION

When ACU define the both signal voltage of the "G" sensor and the safing sensor to be that of collision which exceeds specified level, the driving circuit switches on and feeds the electric ignitor of both driver and passenger air bags and pre-tensioner seat belt.

### STRUCTURE

Integrated type of the "G" sensor element for frontal collision with output terminals for signal voltage.

### INSTALLATION

Crash zone sensor is installed on the radiator core support assembly with fixed nuts.

### DTC Logic

INFOID:000000005252665

#### DTC DETECTION LOGIC

With CONSULT-III

DTC No. Index ("SELF-DIAG [CURRENT]"), ("SELF-DIAG [PAST]" or "TROUBLE DIAG RECORD)

DTC No.	Trouble diagnosis name	DTC detecting condition	Possible cause
B1033 B1034	CRASH ZONE SENSOR [UNIT FAIL]	Crash zone sensor is out of order.	<ul style="list-style-type: none"><li>• Disconnection of wiring harness.</li><li>• Internal breakdown in crash zone sensor.</li><li>• Internal breakdown in diagnosis sensor unit (ACU).</li></ul>

#### DTC CONFIRMATION PROCEDURE (With CONSULT-III)

##### 1.INSPECTION START

Turn ignition switch ON.

>> GO TO 2.

##### 2.CHECK SELF-DIAG RESULT

Check the screen of CONSULT-III.

Is malfunctioning part detected?

- YES >> Refer to [SRC-39, "Diagnosis Procedure"](#).  
NO >> **INSPECTION END.**

#### DTC CONFIRMATION PROCEDURE (Without CONSULT-III)

##### NOTE:

- SRS will not enter diagnosis mode if no malfunction is detected in user mode.

##### 1.INSPECTION START

Turn ignition switch ON.

>> GO TO 2.

# B1033, B1034 CRASH ZONE SEN

< DTC/CIRCUIT DIAGNOSIS >

[FOR USA AND CANADA]

## 2.CHECK AIR BAG WARNING LAMP-

Check the warning lamp status.

Is malfunctioning part detected?

- YES >> Refer to [SRC-154, "DTC Index"](#).
- NO >> **INSPECTION END.**

### Diagnosis Procedure

INFOID:000000005252666

With CONSULT-III

#### **WARNING:**

- Before servicing, turn ignition switch OFF, disconnect both battery terminals and wait at least 3 minutes. (To discharge backup capacitor.)
- Do not use unspecified tester or other measuring device.

### DIAGNOSTIC PROCEDURE

#### 1.CHECK HARNESS CONNECTOR

Check the connection of harness connector.

Is the inspection result normal?

- YES >> GO TO 2.
- NO >> Repair or replace harness connectors.

#### 2.CHECK WIRING HARNESS

Check the wiring harness externals.

Is the inspection result normal?

- YES >> GO TO 3.
- NO >> Repair or replace wiring harness.

#### 3.CHECK CRASH ZONE SENSOR

1. Replace crash zone sensor.
2. Check the screen of CONSULT-III.

Is the inspection result normal?

- YES >> **INSPECTION END.**
- NO >> Check the intermittent incident. Refer to [GI-40, "Intermittent Incident"](#).

A  
B  
C  
D  
E  
F  
G  
I  
J  
K  
L  
M  
N  
O  
P

SRC

# B1035, B1036, B1038, B1040 CRASH ZONE SEN

< DTC/CIRCUIT DIAGNOSIS >

[FOR USA AND CANADA]

## B1035, B1036, B1038, B1040 CRASH ZONE SEN

### Description

INFOID:000000005252667

#### DTC B1035, B1036, B1038, B1040 [COMM FAIL] CRASH ZONE SENSOR

Main "G" sensor that generates signal voltage, when it detects deceleration beyond the specified level caused by vehicle frontal collision.

### OPERATION

When ACU defines both signal voltage of the "G" sensor and the safing sensor to be that of collision which exceeds specified level, the driving circuit switches on and feeds the electric ignitor of both driver and passenger air bags and pre-tensioner seat belt.

### STRUCTURE

Integrated type of the "G" sensor element for frontal collision with output terminals for signal voltage.

### INSTALLATION

Crash zone sensor is installed on the radiator core support assembly with fixed nuts.

### DTC Logic

INFOID:000000005252668

### DTC DETECTION LOGIC

With CONSULT-III

DTC No. Index ("SELF-DIAG [CURRENT]"), ("SELF-DIAG [PAST]" or "TROUBLE DIAG RECORD")

DTC No.	Trouble diagnosis name	DTC detecting condition	Possible cause
B1035	CRASH ZONE SENSOR [COMM FAIL]	Crash zone sensor is out of order.	<ul style="list-style-type: none"><li>• Disconnection of wiring harness and open/short.</li><li>• Internal breakdown in crash zone sensor.</li><li>• Internal breakdown in diagnosis sensor unit (ACU).</li></ul>
B1036	[UNMATCH]		
B1038	[OPEN/UPR-VB-SHORT]		
B1040	[SHORT/UPR-GND-SHORT]		

### DTC CONFIRMATION PROCEDURE (With CONSULT-III)

#### 1.INSPECTION START

Turn ignition switch ON.

>> GO TO 2.

#### 2.CHECK SELF-DIAG RESULT

Check the screen of CONSULT-III.

Is malfunctioning part detected?

- YES >> Refer to [SRC-41. "Diagnosis Procedure"](#).  
NO >> **INSPECTION END.**

### DTC CONFIRMATION PROCEDURE (Without CONSULT-III)

#### NOTE:

- SRS will not enter diagnosis mode if no malfunction is detected in user mode.

#### 1.INSPECTION START

Turn ignition switch ON.



# B1035, B1036, B1038, B1040 CRASH ZONE SEN

< DTC/CIRCUIT DIAGNOSIS >

[FOR USA AND CANADA]

>> GO TO 2.

## 2.CHECK AIR BAG WARNING LAMP

Check the warning lamp status.

Is malfunctioning part detected?

YES >> Refer to [SRC-154, "DTC Index"](#).

NO >> **INSPECTION END.**

## Diagnosis Procedure

INFOID:000000005252669

With CONSULT-III

### **WARNING:**

- Before servicing, turn ignition switch OFF, disconnect both battery terminals and wait at least 3 minutes. (To discharge backup capacitor.)
- Do not use unspecified tester or other measuring device.

## DIAGNOSTIC PROCEDURE

### 1.CHECK HARNESS CONNECTOR

Check the connection of harness connector.

Is the inspection result normal?

YES >> GO TO 2.

NO >> Repair or replace harness connectors.

### 2.CHECK WIRING HARNESS

Check the wiring harness externals.

Is the inspection result normal?

YES >> GO TO 3.

NO >> Repair or replace wiring harness.

### 3.CHECK CRASH ZONE SENSOR

1. Replace crash zone sensor.
2. Check the screen of CONSULT-III.

Is the inspection result normal?

YES >> **INSPECTION END.**

NO >> Check the intermittent incident. Refer to [GI-40, "Intermittent Incident"](#).

A  
B  
C  
D  
E  
F  
G  
H  
I  
J  
K  
L  
M  
N  
O  
P

SRC

# B1042, B1043, B1044, B1045, B1046, B1047 DIAGNOSIS SENSOR UNIT

< DTC/CIRCUIT DIAGNOSIS >

[FOR USA AND CANADA]

## B1042, B1043, B1044, B1045, B1046, B1047 DIAGNOSIS SENSOR UNIT

### Description

INFOID:000000005252670

#### DTC B1042, B1043, B1044, B1045, B1046, B1047 DIAGNOSIS SENSOR UNIT

Detects the whole SRS electrical system and displays the malfunction either by illuminating or blinking the air bag warning lamp in the combination meter. Malfunctioning part can be detected by on board self-diagnosis system and electro-diagnosis tester CONSULT-III.

### OPERATION

It detects a shock that exceeds specified level and monitors such systems as the driver and passenger air bag, side air bag, curtain air bag, pre-tensioner seat belts and Occupant Classification System (OCS) operate properly.

### STRUCTURE

It contains the "G" sensors for both for frontal and side collisions and spare battery function in case of main battery damage in collision.

### INSTALLATION

SRS diagnosis sensor unit is installed under the center console with fixed bolts.

### DTC Logic

INFOID:000000005252671

### DTC DETECTION LOGIC

With CONSULT-III

DTC No. Index ("SELF-DIAG [CURRENT]"), ("SELF-DIAG [PAST]" or "TROUBLE DIAG RECORD")

DTC No.	Trouble diagnosis name	DTC detecting condition	Possible cause
B1042 B1043 B1044 B1045 B1046 B1047	CONTROL UNIT	Diagnosis sensor unit is out of order.	Internal breakdown in diagnosis sensor unit (ACU).

### DTC CONFIRMATION PROCEDURE (With CONSULT-III)

#### 1.INSPECTION START

Turn ignition switch ON.

>> GO TO 2.

#### 2.CHECK SELF-DIAG RESULT

Check the screen of CONSULT-III.

Is malfunctioning part detected?

- YES >> Refer to [SRC-43, "Diagnosis Procedure"](#).
- NO >> **INSPECTION END.**

### DTC CONFIRMATION PROCEDURE (Without CONSULT-III)

#### NOTE:

- SRS will not enter diagnosis mode if no malfunction is detected in user mode.

#### 1.INSPECTION START

Turn ignition switch ON.

# B1042, B1043, B1044, B1045, B1046, B1047 DIAGNOSIS SENSOR UNIT

< DTC/CIRCUIT DIAGNOSIS >

[FOR USA AND CANADA]

>> GO TO 2.

## 2.CHECK AIR BAG WARNING LAMP

Check the warning lamp status.

Is malfunctioning part detected?

YES >> Refer to [SRC-154, "DTC Index"](#).

NO >> **INSPECTION END.**

## Diagnosis Procedure

INFOID:000000005252672

With CONSULT-III

### **WARNING:**

- Before servicing, turn ignition switch OFF, disconnect both battery terminals and wait at least 3 minutes. (To discharge backup capacitor.)
- Do not use unspecified tester or other measuring device.

## DIAGNOSTIC PROCEDURE

### 1.CHECK HARNESS CONNECTOR

Check the connection of harness connector.

Is the inspection result normal?

YES >> GO TO 2.

NO >> Repair or replace harness connectors.

### 2.CHECK WIRING HARNESS

Check the wiring harness externals.

Is the inspection result normal?

YES >> GO TO 3.

NO >> Repair or replace wiring harness.

### 3.CHECK DIAGNOSIS SENSOR UNIT

1. Replace diagnosis sensor unit (ACU).

2. Check the screen of CONSULT-III.

Is the inspection result normal?

YES >> **INSPECTION END.**

NO >> Check the intermittent incident. Refer to [GI-40, "Intermittent Incident"](#).

A  
B  
C  
D  
E  
F  
G  
H  
I  
J  
K  
L  
M  
N  
O  
P

SRC

# B1049, B1054 DRIVER AIRBAG MODULE

< DTC/CIRCUIT DIAGNOSIS >

[FOR USA AND CANADA]

## B1049, B1054 DRIVER AIRBAG MODULE

### Description

INFOID:000000005252673

#### DTC B1049, B1054 [OPEN] DRIVER AIRBAG MODULE

For driver air bag module, crash is judged by main "G" sensor output signal and sub "G" sensor in front direction.

### OPERATION

In case of frontal collision whose acceleration exceeds the specified level, the ignition materials are ignited by electric ignition system. The system burns and introduces the chemical reaction of gas generating materials to generate hot gases that flow into the air bag through a filter and expand the bag.

### STRUCTURE

Driver air bag module mainly consists of air bag and inflator which inflates air bag.

### INSTALLATION

Driver air bag module is installed on the center of steering wheel with fixed bolts.

### DTC Logic

INFOID:000000005252674

#### DTC DETECTION LOGIC

With CONSULT-III

DTC No. Index ("SELF-DIAG [CURRENT]"), ("SELF-DIAG [PAST]" or "TROUBLE DIAG RECORD")

DTC No.	Trouble diagnosis name	DTC detecting condition	Possible cause
B1049 B1054	DRIVER AIRBAG MODULE [OPEN]	Driver air bag module circuit is open. (including the spiral cable.)	<ul style="list-style-type: none"><li>• Disconnection of wiring harness and open.</li><li>• Internal breakdown in driver air bag module.</li><li>• Internal breakdown in spiral cable.</li><li>• Internal breakdown in diagnosis sensor unit (ACU).</li></ul>

#### DTC CONFIRMATION PROCEDURE (With CONSULT-III)

##### 1.INSPECTION START

Turn ignition switch ON.

>> GO TO 2.

##### 2.CHECK SELF-DIAG RESULT

Check the screen of CONSULT-III.

Is malfunctioning part detected?

YES >> Refer to [SRC-45. "Diagnosis Procedure"](#).

NO >> **INSPECTION END.**

#### DTC CONFIRMATION PROCEDURE (Without CONSULT-III)

##### NOTE:

- SRS will not enter diagnosis mode if no malfunction is detected in user mode.

##### 1.INSPECTION START

Turn ignition switch ON.

# B1049, B1054 DRIVER AIRBAG MODULE

< DTC/CIRCUIT DIAGNOSIS >

[FOR USA AND CANADA]

>> GO TO 2.

## 2.CHECK AIR BAG WARNING LAMP

Check the warning lamp status.

Is malfunctioning part detected?

YES >> Refer to [SRC-154, "DTC Index"](#).

NO >> **INSPECTION END.**

## Diagnosis Procedure

INFOID:000000005252675

With CONSULT-III

### **WARNING:**

- **Before servicing, turn ignition switch OFF, disconnect both battery terminals and wait at least 3 minutes. (To discharge backup capacitor.)**
- **Do not use unspecified tester or other measuring device.**

## DIAGNOSTIC PROCEDURE

### 1.CHECK HARNESS CONNECTOR

Check the connection of harness connector.

Is the inspection result normal?

YES >> GO TO 2.

NO >> Repair or replace harness connector.

### 2.CHECK WIRING HARNESS

Check the wiring harness externals.

Is the inspection result normal?

YES >> GO TO 3.

NO >> Repair or replace wiring harness.

### 3.CHECK DRIVER AIR BAG MODULE

1. Replace driver air bag module.
2. Check the screen of CONSULT-III.

Is the inspection result normal?

YES >> **INSPECTION END.**

NO >> GO TO 4.

### 4.CHECK SPIRAL CABLE CIRCUIT

1. Turn ignition switch OFF.
2. Disconnect driver side air bag module harness connector and body side harness connector.
3. Check continuity between driver side air bag module harness connector and body side harness connector.

Driver side air bag module harness connector	Terminal	Body side harness connector	Terminal	Continuity
M350	10 11	M32	30 23	Existed
M351	13 12		23 28	

4. Check continuity between driver side air bag module harness connector and ground.

Driver side air bag module harness connector	Terminal		Continuity
M350	10 11	Ground	Not existed
M351	13 12		

## B1049, B1054 DRIVER AIRBAG MODULE

< DTC/CIRCUIT DIAGNOSIS >

[FOR USA AND CANADA]

---

Is the inspection result normal?

YES >> Check the intermittent incident. Refer to [GI-40, "Intermittent Incident"](#).

NO >> Replace spiral cable.

# B1050, B1055 DRIVER AIRBAG MODULE

< DTC/CIRCUIT DIAGNOSIS >

[FOR USA AND CANADA]

## B1050, B1055 DRIVER AIRBAG MODULE

### Description

INFOID:000000005252676

### DTC B1050, B1055 [VB-SHORT] DRIVER AIRBAG MODULE

For driver air bag module, crash is judged by main "G" sensor output signal and sub "G" sensor in front direction.

### OPERATION

In case of frontal collision whose acceleration exceeds the specified level, the ignition materials are ignited by electric ignition system. The system burns and introduces the chemical reaction of gas generating materials to generate hot gases that flow into the air bag through a filter and expand the bag.

### STRUCTURE

Driver air bag module mainly consists of air bag and inflator which inflates air bag.

### INSTALLATION

Driver air bag module is installed on the center of steering wheel with fixed bolts.

### DTC Logic

INFOID:000000005252677

### DTC DETECTION LOGIC

With CONSULT-III

DTC No. Index ("SELF-DIAG [CURRENT]"), ("SELF-DIAG [PAST]" or "TROUBLE DIAG RECORD")

DTC No.	Trouble diagnosis name	DTC detecting condition	Possible cause
B1050 B1055	DRIVER AIRBAG MODULE [VB-SHORT]	Driver air bag module circuit is shorted to some power supply circuit. (including the spiral cable.)	<ul style="list-style-type: none"><li>• Disconnection of wiring harness and short.</li><li>• Internal breakdown in driver air bag module.</li><li>• Internal breakdown in spiral cable.</li><li>• Internal breakdown in diagnosis sensor unit (ACU).</li></ul>

### DTC CONFIRMATION PROCEDURE (With CONSULT-III)

#### 1.INSPECTION START

Turn ignition switch ON.

>> GO TO 2.

#### 2.CHECK SELF-DIAG RESULT

Check the screen of CONSULT-III.

Is malfunctioning part detected?

YES >> Refer to [SRC-48. "Diagnosis Procedure"](#).

NO >> **INSPECTION END.**

### DTC CONFIRMATION PROCEDURE (Without CONSULT-III)

#### NOTE:

- SRS will not enter diagnosis mode if no malfunction is detected in user mode.

#### 1.INSPECTION START

Turn ignition switch ON.

A  
B  
C  
D  
E  
F  
G  
I  
J  
K  
L  
M  
N  
O  
P

SRC

# B1050, B1055 DRIVER AIRBAG MODULE

< DTC/CIRCUIT DIAGNOSIS >

[FOR USA AND CANADA]

>> GO TO 2.

## 2.CHECK AIR BAG WARNING LAMP

Check the warning lamp status.

Is malfunctioning part detected?

YES >> Refer to [SRC-154. "DTC Index"](#).

NO >> **INSPECTION END.**

## Diagnosis Procedure

INFOID:000000005252678

With CONSULT-III

### **WARNING:**

- **Before servicing, turn ignition switch OFF, disconnect both battery terminals and wait at least 3 minutes. (To discharge backup capacitor.)**
- **Do not use unspecified tester or other measuring device.**

## DIAGNOSTIC PROCEDURE

### 1.CHECK HARNESS CONNECTOR

Check the connection of harness connector.

Is the inspection result normal?

YES >> GO TO 2.

NO >> Repair or replace harness connector.

### 2.CHECK WIRING HARNESS

Check the wiring harness externals.

Is the inspection result normal?

YES >> GO TO 3.

NO >> Repair or replace wiring harness.

### 3.CHECK DRIVER AIR BAG MODULE

1. Replace driver air bag module.
2. Check the screen of CONSULT-III.

Is the inspection result normal?

YES >> **INSPECTION END.**

NO >> GO TO 4.

### 4.CHECK SPIRAL CABLE CIRCUIT

1. Turn ignition switch OFF.
2. Disconnect driver side air bag module harness connector and body side harness connector.
3. Check continuity between driver side air bag module harness connector and body side harness connector.

Driver side air bag module harness connector	Terminal	Body side harness connector	Terminal	Continuity
M350	10 11	M32	30 23	Existed
M351	13 12		23 28	

4. Check continuity between driver side air bag module harness connector and ground.

Driver side air bag module harness connector	Terminal		Continuity
M350	10 11	Ground	Not existed
M351	13 12		



# B1050, B1055 DRIVER AIRBAG MODULE

< DTC/CIRCUIT DIAGNOSIS >

[FOR USA AND CANADA]

Is the inspection result normal?

YES >> Check the intermittent incident. Refer to [GI-40, "Intermittent Incident"](#).

NO >> Replace spiral cable.

A

B

C

D

E

F

G

**SRC**

I

J

K

L

M

N

O

P

# B1051, B1056 DRIVER AIRBAG MODULE

< DTC/CIRCUIT DIAGNOSIS >

[FOR USA AND CANADA]

## B1051, B1056 DRIVER AIRBAG MODULE

### Description

INFOID:000000005252679

#### DTC B1051, B1056 [GND-SHORT] DRIVER AIRBAG MODULE

For driver air bag module, crash is judged by main "G" sensor output signal and sub "G" sensor in front direction.

### OPERATION

In case of frontal collision whose acceleration exceeds the specified level, the ignition materials are ignited by electric ignition system. The system burns and introduces the chemical reaction of gas generating materials to generate hot gases that flow into the air bag through a filter and expand the bag.

### STRUCTURE

Driver air bag module mainly consists of air bag and inflator which inflates air bag.

### INSTALLATION

Driver air bag module is installed on the center of steering wheel with fixed bolts.

### DTC Logic

INFOID:000000005252680

#### DTC DETECTION LOGIC

With CONSULT-III

DTC No. Index ("SELF-DIAG [CURRENT]"), ("SELF-DIAG [PAST]" or "TROUBLE DIAG RECORD")

DTC No.	Trouble diagnosis name	DTC detecting condition	Possible cause
B1051 B1056	DRIVER AIRBAG MODULE [GND-SHORT]	Driver air bag module circuit is shorted to ground. (including the spiral cable.)	<ul style="list-style-type: none"><li>• Disconnection of wiring harness and short.</li><li>• Internal breakdown in driver air bag module.</li><li>• Internal breakdown in spiral cable.</li><li>• Internal breakdown in diagnosis sensor unit (ACU).</li></ul>

#### DTC CONFIRMATION PROCEDURE (With CONSULT-III)

##### 1.INSPECTION START

Turn ignition switch ON.

>> GO TO 2.

##### 2.CHECK SELF-DIAG RESULT

Check the screen of CONSULT-III.

Is malfunctioning part detected?

YES >> Refer to [SRC-51. "Diagnosis Procedure"](#).

NO >> **INSPECTION END.**

#### DTC CONFIRMATION PROCEDURE (Without CONSULT-III)

##### NOTE:

- SRS will not enter diagnosis mode if no malfunction is detected in user mode.

##### 1.INSPECTION START

Turn ignition switch ON.

# B1051, B1056 DRIVER AIRBAG MODULE

< DTC/CIRCUIT DIAGNOSIS >

[FOR USA AND CANADA]

>> GO TO 2.

## 2. CHECK AIR BAG WARNING LAMP

Check the warning lamp status.

Is malfunctioning part detected?

YES >> Refer to [SRC-154, "DTC Index"](#).

NO >> **INSPECTION END.**

## Diagnosis Procedure

INFOID:000000005252681

With CONSULT-III

### **WARNING:**

- Before servicing, turn ignition switch OFF, disconnect both battery terminals and wait at least 3 minutes. (To discharge backup capacitor.)
- Do not use unspecified tester or other measuring device.

## DIAGNOSTIC PROCEDURE

### 1. CHECK HARNESS CONNECTOR

Check the connection of harness connector.

Is the inspection result normal?

YES >> GO TO 2.

NO >> Repair or replace harness connector.

### 2. CHECK WIRING HARNESS

Check the wiring harness externals.

Is the inspection result normal?

YES >> GO TO 3.

NO >> Repair or replace wiring harness.

### 3. CHECK DRIVER AIR BAG MODULE

1. Replace driver air bag module.
2. Check the screen of CONSULT-III.

Is the inspection result normal?

YES >> **INSPECTION END.**

NO >> GO TO 4.

### 4. CHECK SPIRAL CABLE CIRCUIT

1. Turn ignition switch OFF.
2. Disconnect driver side air bag module harness connector and body side harness connector.
3. Check continuity between driver side air bag module harness connector and body side harness connector.

Driver side air bag module harness connector	Terminal	Body side harness connector	Terminal	Continuity
M350	10 11	M32	30 23	Existed
M351	13 12		23 28	

4. Check continuity between driver side air bag module harness connector and ground.

Driver side air bag module harness connector	Terminal		Continuity
M350	10 11	Ground	Not existed
M351	13 12		

## B1051, B1056 DRIVER AIRBAG MODULE

< DTC/CIRCUIT DIAGNOSIS >

[FOR USA AND CANADA]

---

Is the inspection result normal?

YES >> Check the intermittent incident. Refer to [GI-40, "Intermittent Incident"](#).

NO >> Replace spiral cable.

# B1052, B1057 DRIVER AIRBAG MODULE

< DTC/CIRCUIT DIAGNOSIS >

[FOR USA AND CANADA]

## B1052, B1057 DRIVER AIRBAG MODULE

### Description

INFOID:000000005252682

### DTC B1052, B1057 [SHORT] DRIVER AIRBAG MODULE

For driver air bag module, crash is judged by main "G" sensor output signal and sub "G" sensor in front direction.

### OPERATION

In case of frontal collision whose acceleration exceeds the specified level, the ignition materials are ignited by electric ignition system. The system burns and introduces the chemical reaction of gas generating materials to generate hot gases that flow into the air bag through a filter and expand the bag.

### STRUCTURE

Driver air bag module mainly consists of air bag and inflator which inflates air bag.

### INSTALLATION

Driver air bag module is installed on the center of steering wheel with fixed bolts.

### DTC Logic

INFOID:000000005252683

### DTC DETECTION LOGIC

With CONSULT-III

DTC No. Index ("SELF-DIAG [CURRENT]"), ("SELF-DIAG [PAST]" or "TROUBLE DIAG RECORD")

SRC

DTC No.	Trouble diagnosis name	DTC detecting condition	Possible cause
B1052 B1057	DRIVER AIRBAG MODULE [SHORT]	Driver air bag module circuit are shorted to each other. (including the spiral cable.)	<ul style="list-style-type: none"> <li>• Disconnection of wiring harness and short.</li> <li>• Internal breakdown in driver air bag module.</li> <li>• Internal breakdown in spiral cable.</li> <li>• Internal breakdown in diagnosis sensor unit (ACU).</li> </ul>

### DTC CONFIRMATION PROCEDURE (With CONSULT-III)

#### 1.INSPECTION START

Turn ignition switch ON.

>> GO TO 2.

#### 2.CHECK SELF-DIAG RESULT

Check the screen of CONSULT-III.

Is malfunctioning part detected?

YES >> Refer to [SRC-54. "Diagnosis Procedure"](#).

NO >> **INSPECTION END.**

### DTC CONFIRMATION PROCEDURE (Without CONSULT-III)

#### NOTE:

- SRS will not enter diagnosis mode if no malfunction is detected in user mode.

#### 1.INSPECTION START

Turn ignition switch ON.

# B1052, B1057 DRIVER AIRBAG MODULE

< DTC/CIRCUIT DIAGNOSIS >

[FOR USA AND CANADA]

>> GO TO 2.

## 2.CHECK AIR BAG WARNING LAMP

Check the warning lamp status.

Is malfunctioning part detected?

YES >> Refer to [SRC-154, "DTC Index"](#).

NO >> **INSPECTION END.**

## Diagnosis Procedure

INFOID:000000005252684

With CONSULT-III

### **WARNING:**

- **Before servicing, turn ignition switch OFF, disconnect both battery terminals and wait at least 3 minutes. (To discharge backup capacitor.)**
- **Do not use unspecified tester or other measuring device.**

## DIAGNOSTIC PROCEDURE

### 1.CHECK HARNESS CONNECTOR

Check the connection of harness connector.

Is the inspection result normal?

YES >> GO TO 2.

NO >> Repair or replace harness connector.

### 2.CHECK WIRING HARNESS

Check the wiring harness externals.

Is the inspection result normal?

YES >> GO TO 3.

NO >> Repair or replace wiring harness.

### 3.CHECK DRIVER AIR BAG MODULE

1. Replace driver air bag module.
2. Check the screen of CONSULT-III.

Is the inspection result normal?

YES >> **INSPECTION END.**

NO >> GO TO 4.

### 4.CHECK SPIRAL CABLE CIRCUIT

1. Turn ignition switch OFF.
2. Disconnect driver side air bag module harness connector and body side harness connector.
3. Check continuity between driver side air bag module harness connector and body side harness connector.

Driver side air bag module harness connector	Terminal	Body side harness connector	Terminal	Continuity
M350	10 11	M32	30 23	Existed
M351	13 12		23 28	

4. Check continuity between driver side air bag module harness connector and ground.

Driver side air bag module harness connector	Terminal		Continuity
M350	10 11	Ground	Not existed
M351	13 12		

# B1052, B1057 DRIVER AIRBAG MODULE

< DTC/CIRCUIT DIAGNOSIS >

[FOR USA AND CANADA]

Is the inspection result normal?

YES >> Check the intermittent incident. Refer to [GI-40, "Intermittent Incident"](#).

NO >> Replace spiral cable.

A

B

C

D

E

F

G

**SRC**

I

J

K

L

M

N

O

P

# B1058, B1059, B1060, B1061, B1062, B1063 DIAGNOSIS SENSOR UNIT

< DTC/CIRCUIT DIAGNOSIS >

[FOR USA AND CANADA]

## B1058, B1059, B1060, B1061, B1062, B1063 DIAGNOSIS SENSOR UNIT

### Description

INFOID:000000005252685

#### DTC B1058, B1059, B1060, B1061, B1062, B1063 DIAGNOSIS SENSOR UNIT

Detects the whole SRS electrical system and displays the malfunction either by illuminating or blinking the air bag warning lamp in the combination meter. Malfunctioning part can be detected by on board self-diagnosis system and electro-diagnosis tester CONSULT-III.

### OPERATION

It detects a shock that exceeds specified level and monitors such systems as the driver and passenger air bag, side air bag, curtain air bag, pre-tensioner seat belts and Occupant Classification System (OCS) operate properly.

### STRUCTURE

It contains the "G" sensors for both frontal and side collisions and spare battery function in case of main battery damage in collision.

### INSTALLATION

SRS diagnosis sensor unit is installed under the center console with fixed bolts.

### DTC Logic

INFOID:000000005252686

### DTC DETECTION LOGIC

With CONSULT-III

DTC No. Index ("SELF-DIAG [CURRENT]"), ("SELF-DIAG [PAST]" or "TROUBLE DIAG RECORD")

DTC No.	Trouble diagnosis name	DTC detecting condition	Possible cause
B1058 B1059 B1060 B1061 B1062 B1063	CONTROL UNIT	Diagnosis sensor unit is out of order.	Internal breakdown in diagnosis sensor unit (ACU).

### DTC CONFIRMATION PROCEDURE (With CONSULT-III)

#### 1.INSPECTION START

Turn ignition switch ON.

>> GO TO 2.

#### 2.CHECK SELF-DIAG RESULT

Check the screen of CONSULT-III.

Is malfunctioning part detected?

- YES >> Refer to [SRC-57, "Diagnosis Procedure"](#).
- NO >> **INSPECTION END.**

### DTC CONFIRMATION PROCEDURE (Without CONSULT-III)

#### NOTE:

- SRS will not enter diagnosis mode if no malfunction is detected in user mode.

#### 1.INSPECTION START

Turn ignition switch ON.



# B1058, B1059, B1060, B1061, B1062, B1063 DIAGNOSIS SENSOR UNIT

< DTC/CIRCUIT DIAGNOSIS >

[FOR USA AND CANADA]

>> GO TO 2.

## 2.CHECK AIR BAG WARNING LAMP

Check the warning lamp status.

Is malfunctioning part detected?

YES >> Refer to [SRC-154, "DTC Index"](#).

NO >> **INSPECTION END.**

## Diagnosis Procedure

INFOID:000000005252687

With CONSULT-III

### **WARNING:**

- Before servicing, turn ignition switch OFF, disconnect both battery terminals and wait at least 3 minutes. (To discharge backup capacitor.)
- Do not use unspecified tester or other measuring device.

## DIAGNOSTIC PROCEDURE

### 1.CHECK HARNESS CONNECTOR

Check the connection of harness connector.

Is the inspection result normal?

YES >> GO TO 2.

NO >> Repair or replace harness connectors.

### 2.CHECK WIRING HARNESS

Check the wiring harness externals.

Is the inspection result normal?

YES >> GO TO 3.

NO >> Replace wiring harness.

### 3.CHECK DIAGNOSIS SENSOR UNIT

1. Replace diagnosis sensor unit (ACU).

2. Check the screen of CONSULT-III.

Is the inspection result normal?

YES >> **INSPECTION END.**

NO >> Check the intermittent incident. Refer to [GI-40, "Intermittent Incident"](#).

A  
B  
C  
D  
E  
F  
G  
H  
I  
J  
K  
L  
M  
N  
O  
P

SRC

# B1065, B1070 ASSIST A/B MODULE

< DTC/CIRCUIT DIAGNOSIS >

[FOR USA AND CANADA]

## B1065, B1070 ASSIST A/B MODULE

### Description

INFOID:000000005252688

#### DTC B 1065, B1070 [OPEN] ASSIST A/B MODULE

For front passenger air bag module, crash is judged by main "G" sensor output signal and sub "G" sensor in front direction.

### OPERATION

In the case of a frontal collision whose acceleration exceeds the specified level, the ignition materials are ignited by electric ignition system. The system burns and introduces the chemical reaction of gas generating materials to generate hot gases that flow into the air bag through a filter and expand the bag.

### STRUCTURE

Front passenger air bag module mainly consists of air bag and inflator which inflates air bag.

### INSTALLATION

Front passenger air bag module is installed on the instrument panel with fixed bolts.

### DTC Logic

INFOID:000000005252689

#### DTC DETECTION LOGIC

With CONSULT-III

DTC No. Index ("SELF-DIAG [CURRENT]"), ("SELF-DIAG [PAST]" or "TROUBLE DIAG RECORD")

DTC No.	Trouble diagnosis name	DTC detecting condition	Possible cause
B1065 B1070	ASSIST A/B MODULE [OPEN]	Front passenger air bag module circuit is open.	<ul style="list-style-type: none"><li>• Disconnection of wiring harness and open.</li><li>• Internal breakdown in front passenger air bag module.</li><li>• Internal breakdown in diagnosis sensor unit (ACU).</li></ul>

#### DTC CONFIRMATION PROCEDURE (With CONSULT-III)

##### 1.INSPECTION START

Turn ignition switch ON.

>> GO TO 2.

##### 2.CHECK SELF-DIAG RESULT

Check the screen of CONSULT-III.

Is malfunctioning part detected?

YES >> Refer to [SRC-59, "Diagnosis Procedure"](#).

NO >> **INSPECTION END.**

#### DTC CONFIRMATION PROCEDURE (Without CONSULT-III)

##### NOTE:

- SRS will not enter diagnosis mode if no malfunction is detected in user mode.

##### 1.INSPECTION START

Turn ignition switch ON.

>> GO TO 2.

# B1065, B1070 ASSIST A/B MODULE

< DTC/CIRCUIT DIAGNOSIS >

[FOR USA AND CANADA]

## 2.CHECK AIR BAG WARNING LAMP

Check the warning lamp status.

Is malfunctioning part detected?

- YES >> Refer to [SRC-154, "DTC Index"](#).  
NO >> **INSPECTION END.**

### Diagnosis Procedure

INFOID:000000005252690

With CONSULT-III

#### **WARNING:**

- Before servicing, turn ignition switch OFF, disconnect both battery terminals and wait at least 3 minutes. (To discharge backup capacitor.)
- Do not use unspecified tester or other measuring device.

### DIAGNOSTIC PROCEDURE

## 1.CHECK HARNESS CONNECTOR

Check the connection of harness connector.

Is the inspection result normal?

- YES >> GO TO 2.  
NO >> Repair or replace harness connector.

## 2.CHECK WIRING HARNESS

Check the wiring harness externals.

Is the inspection result normal?

- YES >> GO TO 3.  
NO >> Repair or replace wiring harness.

## 3.CHECK FRONT PASSENGER AIR BAG MODULE

1. Replace front passenger air bag module.
2. Check the screen of CONSULT-III.

Is the inspection result normal?

- YES >> **INSPECTION END.**  
NO >> Check the intermittent incident. Refer to [GI-40, "Intermittent Incident"](#).

A  
B  
C  
D  
E  
F  
G  
I  
J  
K  
L  
M  
N  
O  
P

SRC

**B1066, B1071 ASSIST A/B MODULE**

**Description**

INFOID:000000005252691

**DTC B1066, B1071 [VB-SHORT] ASSIST A/B MODULE**

For front passenger air bag module, crash is judged by main “G” sensor output signal and sub “G” sensor in front direction.

**OPERATION**

In the case of a frontal collision whose acceleration exceeds the specified level, the ignition materials are ignited by electric ignition system. The system burns and introduces the chemical reaction of gas generating materials to generate hot gases that flow into the air bag through a filter and expand the bag.

**STRUCTURE**

Front passenger air bag module mainly consists of air bag and inflator which inflates air bag.

**INSTALLATION**

Front passenger air bag module is installed on the instrument panel with fixed bolts.

**DTC Logic**

INFOID:000000005252692

**DTC DETECTION LOGIC**

With CONSULT-III

DTC No. Index (“SELF-DIAG [CURRENT]”), (“SELF-DIAG [PAST]” or “TROUBLE DIAG RECORD”)

DTC No.	Trouble diagnosis name	DTC detecting condition	Possible cause
B1066 B1071	ASSIST A/B MODULE [VB-SHORT]	Front passenger air bag module circuit is shorted to some power supply circuit.	<ul style="list-style-type: none"> <li>• Disconnection of wiring harness and short.</li> <li>• Internal breakdown in front passenger air bag module.</li> <li>• Internal breakdown in diagnosis sensor unit (ACU).</li> </ul>

**DTC CONFIRMATION PROCEDURE (With CONSULT-III)**

**1.INSPECTION START**

Turn ignition switch ON.

>> GO TO 2.

**2.CHECK SELF-DIAG RESULT**

Check the screen of CONSULT-III.

Is malfunctioning part detected?

YES >> Refer to [SRC-61, "Diagnosis Procedure"](#).

NO >> **INSPECTION END.**

**DTC CONFIRMATION PROCEDURE (Without CONSULT-III)**

**NOTE:**

- SRS will not enter diagnosis mode if no malfunction is detected in user mode.

**1.INSPECTION START**

Turn ignition switch ON.

>> GO TO 2.

# B1066, B1071 ASSIST A/B MODULE

< DTC/CIRCUIT DIAGNOSIS >

[FOR USA AND CANADA]

## 2.CHECK AIR BAG WARNING LAMP

Check the warning lamp status.

Is malfunctioning part detected?

- YES >> Refer to [SRC-154, "DTC Index"](#).
- NO >> **INSPECTION END.**

### Diagnosis Procedure

INFOID:000000005252693

With CONSULT-III

#### **WARNING:**

- Before servicing, turn ignition switch OFF, disconnect both battery terminals and wait at least 3 minutes. (To discharge backup capacitor.)
- Do not use unspecified tester or other measuring device.

### DIAGNOSTIC PROCEDURE

## 1.CHECK HARNESS CONNECTOR

Check the connection of harness connector.

Is the inspection result normal?

- YES >> GO TO 2.
- NO >> Repair or replace harness connector.

## 2.CHECK WIRING HARNESS

Check the wiring harness externals.

Is the inspection result normal?

- YES >> GO TO 3.
- NO >> Repair or replace wiring harness.

## 3.CHECK FRONT PASSENGER AIR BAG MODULE

1. Replace front passenger air bag module.
2. Check the screen of CONSULT-III.

Is the inspection result normal?

- YES >> **INSPECTION END.**
- NO >> Check the intermittent incident. Refer to [GI-40, "Intermittent Incident"](#).

A  
B  
C  
D  
E  
F  
G  
I  
J  
K  
L  
M  
N  
O  
P

SRC

# B1067, B1072 ASSIST A/B MODULE

< DTC/CIRCUIT DIAGNOSIS >

[FOR USA AND CANADA]

## B1067, B1072 ASSIST A/B MODULE

### Description

INFOID:000000005252694

#### DTC B1067, B1072 [GND-SHORT] ASSIST A/B MODULE

For front passenger air bag module, crash is judged by main "G" sensor output signal and sub "G" sensor in front direction.

### OPERATION

In the case of a frontal collision whose acceleration exceeds the specified level, the ignition materials are ignited by electric ignition system. The system burns and introduces the chemical reaction of gas generating materials to generate hot gases that flow into the air bag through a filter and expand the bag.

### STRUCTURE

Front passenger air bag module mainly consists of air bag and inflator which inflates air bag.

### INSTALLATION

Front passenger air bag module is installed on the instrument panel with fixed bolts.

### DTC Logic

INFOID:000000005252695

#### DTC DETECTION LOGIC

With CONSULT-III

DTC No. Index ("SELF-DIAG [CURRENT]"), ("SELF-DIAG [PAST]" or "TROUBLE DIAG RECORD")

DTC No.	Trouble diagnosis name	DTC detecting condition	Possible cause
B1067 B1072	ASSIST A/B MODULE [GND-SHORT]	Front passenger air bag module circuit is shorted to ground.	<ul style="list-style-type: none"><li>• Disconnection of wiring harness and short.</li><li>• Internal breakdown in front passenger air bag module.</li><li>• Internal breakdown in diagnosis sensor unit (ACU).</li></ul>

#### DTC CONFIRMATION PROCEDURE (With CONSULT-III)

##### 1.INSPECTION START

Turn ignition switch ON.

>> GO TO 2.

##### 2.CHECK SELF-DIAG RESULT

Check the screen of CONSULT-III.

Is malfunctioning part detected?

YES >> Refer to [SRC-63, "Diagnosis Procedure"](#).

NO >> **INSPECTION END.**

#### DTC CONFIRMATION PROCEDURE (Without CONSULT-III)

##### NOTE:

- SRS will not enter diagnosis mode if no malfunction is detected in user mode.

##### 1.INSPECTION START

Turn ignition switch ON.

>> GO TO 2.

# B1067, B1072 ASSIST A/B MODULE

< DTC/CIRCUIT DIAGNOSIS >

[FOR USA AND CANADA]

## 2.CHECK AIR BAG WARNING LAMP

Check the warning lamp status.

Is malfunctioning part detected?

- YES >> Refer to [SRC-154, "DTC Index"](#).
- NO >> **INSPECTION END.**

### Diagnosis Procedure

INFOID:000000005252696

With CONSULT-III

#### **WARNING:**

- Before servicing, turn ignition switch OFF, disconnect both battery terminals and wait at least 3 minutes. (To discharge backup capacitor.)
- Do not use unspecified tester or other measuring device.

### DIAGNOSTIC PROCEDURE

#### 1.CHECK HARNESS CONNECTOR

Check the connection of harness connector.

Is the inspection result normal?

- YES >> GO TO 2.
- NO >> Repair or replace harness connector.

#### 2.CHECK WIRING HARNESS

Check the wiring harness externals.

Is the inspection result normal?

- YES >> GO TO 3.
- NO >> Replace wiring harness.

#### 3.CHECK FRONT PASSENGER AIR BAG MODULE

1. Replace front passenger air bag module.
2. Check the screen of CONSULT-III.

Is the inspection result normal?

- YES >> **INSPECTION END.**
- NO >> Check the intermittent incident. Refer to [GI-40, "Intermittent Incident"](#).

A  
B  
C  
D  
E  
F  
G  
I  
J  
K  
L  
M  
N  
O  
P

SRC

# B1068, B1073 ASSIST A/B MODULE

< DTC/CIRCUIT DIAGNOSIS >

[FOR USA AND CANADA]

## B1068, B1073 ASSIST A/B MODULE

### Description

INFOID:000000005252697

#### DTC B1068, B1073 [SHORT] ASSIST A/B MODULE

For front passenger air bag module, crash is judged by main "G" sensor output signal and sub "G" sensor in front direction.

### OPERATION

In the case of a frontal collision whose acceleration exceeds the specified level, the ignition materials are ignited by electric ignition system. The system burns and introduces the chemical reaction of gas generating materials to generate hot gases that flow into the air bag through a filter and expand the bag.

### STRUCTURE

Front passenger air bag module mainly consists of air bag and inflator which inflates air bag.

### INSTALLATION

Front passenger air bag module is installed on the instrument panel with fixed bolts.

### DTC Logic

INFOID:000000005252698

#### DTC DETECTION LOGIC

With CONSULT-III

DTC No. Index ("SELF-DIAG [CURRENT]"), ("SELF-DIAG [PAST]" or "TROUBLE DIAG RECORD")

DTC No.	Trouble diagnosis name	DTC detecting condition	Possible cause
B1068 B1073	ASSIST A/B MODULE [SHORT]	Front passenger air bag module circuits are shorted to each other.	<ul style="list-style-type: none"><li>• Disconnection of wiring harness and short.</li><li>• Internal breakdown in front passenger air bag module.</li><li>• Internal breakdown in diagnosis sensor unit (ACU).</li></ul>

#### DTC CONFIRMATION PROCEDURE (With CONSULT-III)

##### 1.INSPECTION START

Turn ignition switch ON.

>> GO TO 2.

##### 2.CHECK SELF-DIAG RESULT

Check the screen of CONSULT-III.

Is malfunctioning part detected?

YES >> Refer to [SRC-65, "Diagnosis Procedure"](#).

NO >> **INSPECTION END.**

#### DTC CONFIRMATION PROCEDURE (Without CONSULT-III)

##### NOTE:

- SRS will not enter diagnosis mode if no malfunction is detected in user mode.

##### 1.INSPECTION START

Turn ignition switch ON.

>> GO TO 2.



# B1068, B1073 ASSIST A/B MODULE

< DTC/CIRCUIT DIAGNOSIS >

[FOR USA AND CANADA]

## 2.CHECK AIR BAG WARNING LAMP

Check the warning lamp status.

Is malfunctioning part detected?

- YES >> Refer to [SRC-154, "DTC Index"](#).
- NO >> **INSPECTION END.**

### Diagnosis Procedure

INFOID:000000005252699

With CONSULT-III

#### **WARNING:**

- Before servicing, turn ignition switch OFF, disconnect both battery terminal and wait at least 3 minutes. (To discharge backup capacitor.)
- Do not use unspecified tester or other measuring device.

### DIAGNOSTIC PROCEDURE

#### 1.CHECK HARNESS CONNECTOR

Check the connection of harness connector.

Is the inspection result normal?

- YES >> GO TO 2.
- NO >> Repair or replace harness connector.

#### 2.CHECK WIRING HARNESS

Check the wiring harness externals.

Is the inspection result normal?

- YES >> GO TO 3.
- NO >> Repair or replace wiring harness.

#### 3.CHECK FRONT PASSENGER AIR BAG MODULE

1. Replace front passenger air bag module.
2. Check the screen of CONSULT-III.

Is the inspection result normal?

- YES >> **INSPECTION END.**
- NO >> Check the intermittent incident. Refer to [GI-40, "Intermittent Incident"](#).

A  
B  
C  
D  
E  
F  
G  
I  
J  
K  
L  
M  
N  
O  
P

SRC

# B1074, B1075, B1076, B1077, B1078, B1079 DIAGNOSIS SENSOR UNIT

< DTC/CIRCUIT DIAGNOSIS >

[FOR USA AND CANADA]

## B1074, B1075, B1076, B1077, B1078, B1079 DIAGNOSIS SENSOR UNIT

### Description

INFOID:000000005252700

#### DTC B1074, B1075, B1076, B1077, B1078, B1079 DIAGNOSIS SENSOR UNIT

Detects the whole SRS electrical system and displays the malfunction either by illuminating or blinking the air bag warning lamp in the combination meter. Malfunctioning part can be detected by on board self-diagnosis system and electro-diagnosis tester CONSULT-III.

### OPERATION

It detects a shock that exceeds specified level and monitors such systems as the driver and passenger air bag, side air bag, curtain air bag, pre-tensioner seat belts and Occupant Classification System (OCS) operate properly.

### STRUCTURE

It contains the "G" sensors for both frontal and side collisions and spare battery function in case of main battery damage in collision.

### INSTALLATION

SRS diagnosis sensor unit is installed under the center console with fixed bolts.

### DTC Logic

INFOID:000000005252701

### DTC DETECTION LOGIC

With CONSULT-III

DTC No. Index ("SELF-DIAG [CURRENT]"), ("SELF-DIAG [PAST]" or "TROUBLE DIAG RECORD")

DTC No.	Trouble diagnosis name	DTC detecting condition	Possible cause
B1074 B1075 B1076 B1077 B1078 B1079	CONTROL UNIT	Diagnosis sensor unit is out of order.	Internal breakdown in diagnosis sensor unit (ACU).

### DTC CONFIRMATION PROCEDURE (With CONSULT-III)

#### 1.INSPECTION START

Turn ignition switch ON.

>> GO TO 2.

#### 2.CHECK SELF-DIAG RESULT

Check the screen of CONSULT-III.

Is malfunctioning part detected?

- YES >> Refer to [SRC-67, "Diagnosis Procedure"](#).
- NO >> **INSPECTION END.**

### DTC CONFIRMATION PROCEDURE (Without CONSULT-III)

#### NOTE:

- SRS will not enter diagnosis mode if no malfunction is detected in user mode.

#### 1.INSPECTION START

Turn ignition switch ON.

# B1074, B1075, B1076, B1077, B1078, B1079 DIAGNOSIS SENSOR UNIT

< DTC/CIRCUIT DIAGNOSIS >

[FOR USA AND CANADA]

>> GO TO 2.

## 2.CHECK AIR BAG WARNING LAMP

Check the warning lamp status.

Is malfunctioning part detected?

YES >> Refer to [SRC-154, "DTC Index"](#).

NO >> **INSPECTION END.**

## Diagnosis Procedure

INFOID:000000005252702

With CONSULT-III

### **WARNING:**

- Before servicing, turn ignition switch OFF, disconnect both battery terminals and wait at least 3 minutes. (To discharge backup capacitor.)
- Do not use unspecified tester or other measuring device.

## DIAGNOSTIC PROCEDURE

### 1.CHECK HARNESS CONNECTOR

Check the connection of harness connector.

Is the inspection result normal?

YES >> GO TO 2.

NO >> Repair or replace harness connectors.

### 2.CHECK WIRING HARNESS

Check the wiring harness externals.

Is the inspection result normal?

YES >> GO TO 3.

NO >> Repair or replace wiring harness.

### 3.CHECK DIAGNOSIS SENSOR UNIT

1. Replace diagnosis sensor unit (ACU).

2. Check the screen of CONSULT-III.

Is the inspection result normal?

YES >> **INSPECTION END.**

NO >> Check the intermittent incident. Refer to [GI-40, "Intermittent Incident"](#).

A  
B  
C  
D  
E  
F  
G  
H  
I  
J  
K  
L  
M  
N  
O  
P

SRC

**B1081 PRE-TEN FRONT RH****Description**

INFOID:000000005252703

**DTC B1081 [OPEN] PRE-TEN FRONT RH**

For front RH seat belt pre-tensioner, crash is judged by main "G" sensor output signal and sub "G" sensor in front direction.

**OPERATION**

In the case of a frontal collision that exceeds specified impact level, the diagnosis sensor unit detects the deceleration caused by collision. If restrains the passenger with seat belt easing the stress on passengers chest with load limiter.

**STRUCTURE**

The restraint system for front seat occupant consists of the pre-tensioner mechanism and load limiter mechanism.

**INSTALLATION**

Front RH seat belt pre-tensioner is installed on the underside of center pillar with fixed nuts.

**DTC Logic**

INFOID:000000005252704

**DTC DETECTION LOGIC**

With CONSULT-III

DTC No. Index ("SELF-DIAG [CURRENT]"), ("SELF-DIAG [PAST]" or "TROUBLE DIAG RECORD")

DTC No.	Trouble diagnosis name	DTC detecting condition	Possible cause
B1081	PRE-TEN FRONT RH [OPEN]	Front RH seat belt pre-tensioner circuit is open.	<ul style="list-style-type: none"> <li>• Disconnection of wiring harness and open.</li> <li>• Internal breakdown in front RH seat belt pre-tensioner.</li> <li>• Internal breakdown in diagnosis sensor unit (ACU).</li> </ul>

**DTC CONFIRMATION PROCEDURE (With CONSULT-III)****1.INSPECTION START**

Turn ignition switch ON.

>> GO TO 2.

**2.CHECK SELF-DIAG RESULT**

Check the screen of CONSULT-III.

Is malfunctioning part detected?

- YES >> Refer to [SRC-69. "Diagnosis Procedure"](#).  
 NO >> **INSPECTION END.**

**DTC CONFIRMATION PROCEDURE (Without CONSULT-III)****NOTE:**

- SRS will not enter diagnosis mode if no malfunction is detected in user mode.

**1.INSPECTION START**

Turn ignition switch ON.

< DTC/CIRCUIT DIAGNOSIS >

>> GO TO 2.

**2.CHECK AIR BAG WARNING LAMP**

Check the warning lamp status.

Is malfunctioning part detected?

- YES >> Refer to [SRC-154, "DTC Index"](#).
- NO >> **INSPECTION END.**

Diagnosis Procedure

INFOID:000000005252705

With CONSULT-III

**WARNING:**

- Before servicing, turn ignition switch OFF, disconnect both battery terminals and wait at least 3 minutes. (To discharge backup capacitor.)
- Do not use unspecified tester or other measuring device.

DIAGNOSTIC PROCEDURE

**1.CHECK HARNESS CONNECTOR**

Check the connection of harness connector.

Is the inspection result normal?

- YES >> GO TO 2.
- NO >> Repair or replace harness connector.

**2.CHECK WIRING HARNESS**

Check the wiring harness externals.

Is the inspection result normal?

- YES >> GO TO 3.
- NO >> Repair or replace wiring harness.

**3.CHECK FRONT SEAT BELT PRE-TENSIONER**

1. Replace front RH seat belt pre-tensioner.
2. Check the screen of CONSULT-III.

Is the inspection result normal?

- YES >> **INSPECTION END.**
- NO >> Check the intermittent incident. Refer to [GI-40, "Intermittent Incident"](#).

A  
B  
C  
D  
E  
F  
G  
I  
J  
K  
L  
M  
N  
O  
P

SRC

**B1082 PRE-TEN FRONT RH****Description**

INFOID:000000005252706

**DTC B1082 [VB-SHORT] PRE-TEN FRONT RH**

For front RH seat belt pre-tensioner, crash is judged by main "G" sensor output signal and sub "G" sensor in front direction.

**OPERATION**

In the case of a frontal collision that exceeds specified impact level, the diagnosis sensor unit detects the deceleration caused by collision. If restrains the passenger with seat belt easing the stress on passengers chest with load limiter.

**STRUCTURE**

The restraint system for front seat occupant consists of the pre-tensioner mechanism and load limiter mechanism.

**INSTALLATION**

Front RH seat belt pre-tensioner is installed on the underside of center pillar with fixed nuts.

**DTC Logic**

INFOID:000000005252707

**DTC DETECTION LOGIC**

With CONSULT-III

DTC No. Index ("SELF-DIAG [CURRENT]"), ("SELF-DIAG [PAST]" or "TROUBLE DIAG RECORD")

DTC No.	Trouble diagnosis name	DTC detecting condition	Possible cause
B1082	PRE-TEN FRONT RH [VB-SHORT]	Front RH seat belt pre-tensioner circuit is shorted to some power supply circuit.	<ul style="list-style-type: none"> <li>• Disconnection of wiring harness and short.</li> <li>• Internal breakdown in front RH seat belt pre-tensioner.</li> <li>• Internal breakdown in diagnosis sensor unit (ACU).</li> </ul>

**DTC CONFIRMATION PROCEDURE (With CONSULT-III)****1.INSPECTION START**

Turn ignition switch ON.

>> GO TO 2.

**2.CHECK SELF-DIAG RESULT**

Check the screen of CONSULT-III.

Is malfunctioning part detected?

- YES >> Refer to [SRC-71. "Diagnosis Procedure"](#).  
 NO >> **INSPECTION END.**

**DTC CONFIRMATION PROCEDURE (Without CONSULT-III)****NOTE:**

- SRS will not enter diagnosis mode if no malfunction is detected in user mode.

**1.INSPECTION START**

Turn ignition switch ON.

< DTC/CIRCUIT DIAGNOSIS >

>> GO TO 2.

2.CHECK AIR BAG WARNING LAMP

Check the warning lamp status.

Is malfunctioning part detected?

YES >> Refer to [SRC-154, "DTC Index"](#).

NO >> **INSPECTION END.**

Diagnosis Procedure

INFOID:000000005252708

With CONSULT-III

**WARNING:**

- Before servicing, turn ignition switch OFF, disconnect both battery terminals and wait at least 3 minutes. (To discharge backup capacitor.)
- Do not use unspecified tester or other measuring device.

DIAGNOSTIC PROCEDURE

1.CHECK HARNESS CONNECTOR

Check the connection of harness connector.

Is the inspection result normal?

YES >> GO TO 2.

NO >> Repair or replace harness connector.

2.CHECK WIRING HARNESS

Check the wiring harness externals.

Is the inspection result normal?

YES >> GO TO 3.

NO >> Repair or replace wiring harness.

3.CHECK FRONT SEAT BELT PRE-TENSIONER

1. Replace front RH seat belt pre-tensioner.

2. Check the screen of CONSULT-III.

Is the inspection result normal?

YES >> **INSPECTION END.**

NO >> Check the intermittent incident. Refer to [GI-40, "Intermittent Incident"](#).

A  
B  
C  
D  
E  
F  
G  
I  
J  
K  
L  
M  
N  
O  
P

SRC

**B1083 PRE-TEN FRONT RH****Description**

INFOID:000000005252709

**DTC B1083 [GND-SHORT] PRE-TEN FRONT RH**

For front RH seat belt pre-tensioner, crash is judged by main “G” sensor output signal and sub “G” sensor in front direction.

**OPERATION**

In case of frontal collision that exceeds specified impact level, the diagnosis sensor unit detects the deceleration caused by collision. If restrains the passenger with seat belt easing the stress on passengers chest with load limiter.

**STRUCTURE**

The restraint system for front seat occupant consists of the pre-tensioner mechanism and load limiter mechanism.

**INSTALLATION**

Front RH seat belt pre-tensioner is installed on the underside of center pillar with fixed nuts.

**DTC Logic**

INFOID:000000005252710

**DTC DETECTION LOGIC**

With CONSULT-III

DTC No. Index (“SELF-DIAG [CURRENT]”), (“SELF-DIAG [PAST]” or “TROUBLE DIAG RECORD”)

DTC No.	Trouble diagnosis name	DTC detecting condition	Possible cause
B1083	PRE-TEN FRONT RH [GND-SHORT]	Front RH seat belt pre-tensioner circuit is shorted to ground.	<ul style="list-style-type: none"> <li>• Disconnection of wiring harness and short.</li> <li>• Internal breakdown in front RH seat belt pre-tensioner.</li> <li>• Internal breakdown in diagnosis sensor unit (ACU).</li> </ul>

**DTC CONFIRMATION PROCEDURE (With CONSULT-III)****1.INSPECTION START**

Turn ignition switch ON.

>> GO TO 2.

**2.CHECK SELF-DIAG RESULT**

Check the screen of CONSULT-III.

Is malfunctioning part detected?

- YES >> Refer to [SRC-73. "Diagnosis Procedure"](#).  
 NO >> **INSPECTION END.**

**DTC CONFIRMATION PROCEDURE (Without CONSULT-III)****NOTE:**

- SRS will not enter diagnosis mode if no malfunction is detected in user mode.

**1.INSPECTION START**

Turn ignition switch ON.



&lt; DTC/CIRCUIT DIAGNOSIS &gt;

&gt;&gt; GO TO 2.

**2.CHECK AIR BAG WARNING LAMP**

Check the warning lamp status.

Is malfunctioning part detected?YES >> Refer to [SRC-154, "DTC Index"](#).NO >> **INSPECTION END.**

## Diagnosis Procedure

INFOID:000000005252711

With CONSULT-III

**WARNING:**

- Before servicing, turn ignition switch OFF, disconnect both battery terminals and wait at least 3 minutes. (To discharge backup capacitor.)
- Do not use unspecified tester or other measuring device.

## DIAGNOSTIC PROCEDURE

**1.CHECK HARNESS CONNECTOR**

Check the connection of harness connector.

Is the inspection result normal?

YES &gt;&gt; GO TO 2.

NO &gt;&gt; Repair or replace harness connector.

**2.CHECK WIRING HARNESS**

Check the wiring harness externals.

Is the inspection result normal?

YES &gt;&gt; GO TO 3.

NO &gt;&gt; Repair or replace wiring harness.

**3.CHECK FRONT SEAT BELT PRE-TENSIONER**

1. Replace front RH seat belt pre-tensioner.

2. Check the screen of CONSULT-III.

Is the inspection result normal?YES >> **INSPECTION END.**NO >> Check the intermittent incident. Refer to [GI-40, "Intermittent Incident"](#).A  
B  
C  
D  
E  
F  
G  
SRC  
I  
J  
K  
L  
M  
N  
O  
P

**B1084 PRE-TEN FRONT RH****Description**

INFOID:000000005252712

**DTC B1084 [SHORT] PRE-TEN FRONT RH**

For front RH seat belt pre-tensioner, crash is judged by main "G" sensor output signal and sub "G" sensor in front direction.

**OPERATION**

In the case of a frontal collision that exceeds specified impact level, the diagnosis sensor unit detects the deceleration caused by collision. If restrains the passenger with seat belt easing the stress on passengers chest with load limiter.

**STRUCTURE**

The restraint system for front seat occupant consists of the pre-tensioner mechanism and load limiter mechanism.

**INSTALLATION**

Front RH seat belt pre-tensioner is installed on the underside of center pillar with fixed nuts.

**DTC Logic**

INFOID:000000005252713

**DTC DETECTION LOGIC**

With CONSULT-III

DTC No. Index ("SELF-DIAG [CURRENT]"), ("SELF-DIAG [PAST]" or "TROUBLE DIAG RECORD")

DTC No.	Trouble diagnosis name	DTC detecting condition	Possible cause
B1084	PRE-TEN FRONT RH [SHORT]	Front RH seat belt pre-tensioner circuit are shorted to each other.	<ul style="list-style-type: none"> <li>• Disconnection of wiring harness and short.</li> <li>• Internal breakdown in front RH seat belt pre-tensioner.</li> <li>• Internal breakdown in diagnosis sensor unit (ACU).</li> </ul>

**DTC CONFIRMATION PROCEDURE (With CONSULT-III)****1.INSPECTION START**

Turn ignition switch ON.

>> GO TO 2.

**2.CHECK SELF-DIAG RESULT**

Check the screen of CONSULT-III.

Is malfunctioning part detected?

- YES >> Refer to [SRC-75. "Diagnosis Procedure"](#).  
 NO >> **INSPECTION END.**

**DTC CONFIRMATION PROCEDURE (Without CONSULT-III)****NOTE:**

- SRS will not enter diagnosis mode if no malfunction is detected in user mode.

**1.INSPECTION START**

Turn ignition switch ON.

< DTC/CIRCUIT DIAGNOSIS >

>> GO TO 2.

2.CHECK AIR BAG WARNING LAMP

Check the warning lamp status.

Is malfunctioning part detected?

YES >> Refer to SRC-154, "DTC Index".

NO >> INSPECTION END.

Diagnosis Procedure

INFOID:000000005252714

With CONSULT-III

WARNING:

- Before servicing, turn ignition switch OFF, disconnect both battery terminals and wait at least 3 minutes. (To discharge backup capacitor.)
- Do not use unspecified tester or other measuring device.

DIAGNOSTIC PROCEDURE

1.CHECK HARNESS CONNECTOR

Check the connection of harness connector.

Is the inspectiion result normal?

YES >> GO TO 2.

NO >> Repair or replace harness connector.

2.CHECK WIRING HARNESS

Check the wiring harness externals.

Is the inspection result normal?

YES >> GO TO 3.

NO >> Repair or replace wiring harness.

3.CHECK FRONT SEAT BELT PRE-TENSIONER

1. Replace front RH seat belt pre-tensioner.

2. Check the screen of CONSULT-III.

Is the inspection result normal?

YES >> INSPECTION END.

NO >> Check the intermittent incident. Refer to GI-40, "Intermittent Incident".

A  
B  
C  
D  
E  
F  
G  
I  
J  
K  
L  
M  
N  
O  
P

SRC

## B1086 PRE-TEN FRONT LH

### Description

INFOID:000000005252715

#### DTC B1086 [OPEN] PRE-TEN FRONT LH

For front LH seat belt pre-tensioner, crash is judged by main “G” sensor output signal and sub “G” sensor in front direction.

### OPERATION

In the case of a frontal collision that exceeds specified impact level, the diagnosis sensor unit detects the deceleration caused by collision. If restrains the passenger with seat belt easing the stress on passengers chest with load limiter.

### STRUCTURE

The restraint system for front seat occupant consists of the pre-tensioner mechanism and load limiter mechanism.

### INSTALLATION

Front LH seat belt pre-tensioner is installed on the underside of center pillar with fixed nuts.

### DTC Logic

INFOID:000000005252716

#### DTC DETECTION LOGIC

With CONSULT-III

DTC No. Index (“SELF-DIAG [CURRENT]”), (“SELF-DIAG [PAST]” or “TROUBLE DIAG RECORD”)

DTC No.	Trouble diagnosis name	DTC detecting condition	Possible cause
B1086	PRE-TEN FRONT LH [OPEN]	Front LH seat belt pre-tensioner circuit is open.	<ul style="list-style-type: none"> <li>• Disconnection of wiring harness and open.</li> <li>• Internal breakdown in front LH seat belt pre-tensioner.</li> <li>• Internal breakdown in diagnosis sensor unit (ACU).</li> </ul>

#### DTC CONFIRMATION PROCEDURE (With CONSULT-III)

##### 1.INSPECTION START

Turn ignition switch ON.

>> GO TO 2.

##### 2.CHECK SELF-DIAG RESULT

Check the screen of CONSULT-III.

Is malfunctioning part detected?

YES >> Refer to [SRC-77. "Diagnosis Procedure"](#).

NO >> **INSPECTION END.**

#### DTC CONFIRMATION PROCEDURE (Without CONSULT-III)

##### NOTE:

- SRS will not enter diagnosis mode if no malfunction is detected in user mode.

##### 1.INSPECTION START

Turn ignition switch ON.

< DTC/CIRCUIT DIAGNOSIS >

>> GO TO 2.

2.CHECK AIR BAG WARNING LAMP

Check the warning lamp status.

Is malfunctioning part detected?

YES >> Refer to [SRC-154, "DTC Index"](#).

NO >> **INSPECTION END.**

Diagnosis Procedure

INFOID:000000005252717

With CONSULT-III

**WARNING:**

- Before servicing, turn ignition switch OFF, disconnect both battery terminals and wait at least 3 minutes. (To discharge backup capacitor.)
- Do not use unspecified tester or other measuring device.

DIAGNOSTIC PROCEDURE

1.CHECK HARNESS CONNECTOR

Check the connection of harness connector.

Is the inspection result normal?

YES >> GO TO 2.

NO >> Repair or replace harness connector.

2.CHECK WIRING HARNESS

Check the wiring harness externals.

Is the inspection result normal?

YES >> GO TO 3.

NO >> Replace wiring harness.

3.CHECK FRONT SEAT BELT PRE-TENSIONER

1. Replace front LH seat belt pre-tensioner.

2. Check the screen of CONSULT-III.

Is the inspection result normal?

YES >> **INSPECTION END.**

NO >> Check the intermittent incident. Refer to [GI-40, "Intermittent Incident"](#).

A  
B  
C  
D  
E  
F  
G  
I  
J  
K  
L  
M  
N  
O  
P

SRC

## B1087 PRE-TEN FRONT LH

### Description

INFOID:000000005252718

#### DTC B1087 [VB-SHORT] PRE-TEN FRONT LH

For front LH seat belt pre-tensioner, crash is judged by main “G” sensor output signal and sub “G” sensor in front direction.

### OPERATION

In the case of a frontal collision that exceeds specified impact level, the diagnosis sensor unit detects the deceleration caused by collision. If restrains the passenger with seat belt easing the stress on passengers chest with load limiter.

### STRUCTURE

The restraint system for front seat occupant consists of the pre-tensioner mechanism and load limiter mechanism.

### INSTALLATION

Front LH seat belt pre-tensioner is installed on the underside of center pillar with fixed nuts.

### DTC Logic

INFOID:000000005252719

#### DTC DETECTION LOGIC

With CONSULT-III

DTC No. Index (“SELF-DIAG [CURRENT]”), (“SELF-DIAG [PAST]” or “TROUBLE DIAG RECORD”)

DTC No.	Trouble diagnosis name	DTC detecting condition	Possible cause
B1087	PRE-TEN FRONT LH [VB-SHORT]	Front LH seat belt pre-tensioner circuit is shorted to some power supply circuit.	<ul style="list-style-type: none"> <li>• Disconnection of wiring harness and short.</li> <li>• Internal breakdown in front LH seat belt pre-tensioner.</li> <li>• Internal breakdown in diagnosis sensor unit (ACU).</li> </ul>

#### DTC CONFIRMATION PROCEDURE (With CONSULT-III)

##### 1.INSPECTION START

Turn ignition switch ON.

>> GO TO 2.

##### 2.CHECK SELF-DIAG RESULT

Check the screen of CONSULT-III.

Is malfunctioning part detected?

YES >> Refer to [SRC-79. "Diagnosis Procedure"](#).

NO >> **INSPECTION END.**

#### DTC CONFIRMATION PROCEDURE (Without CONSULT-III)

##### NOTE:

- SRS will not enter diagnosis mode if no malfunction is detected in user mode.

##### 1.INSPECTION START

Turn ignition switch ON.

< DTC/CIRCUIT DIAGNOSIS >

>> GO TO 2.

**2.CHECK AIR BAG WARNING LAMP**

Check the warning lamp status.

Is malfunctioning part detected?

YES >> Refer to [SRC-154, "DTC Index"](#).

NO >> **INSPECTION END.**

Diagnosis Procedure

INFOID:000000005252720

With CONSULT-III

**WARNING:**

- Before servicing, turn ignition switch OFF, disconnect both battery terminals and wait at least 3 minutes. (To discharge backup capacitor.)
- Do not use unspecified tester or other measuring device.

DIAGNOSTIC PROCEDURE

**1.CHECK HARNESS CONNECTOR**

Check the connection of harness connector.

Is the inspection result normal?

YES >> GO TO 2.

NO >> Repair or replace harness connector.

**2.CHECK WIRING HARNESS**

Check the wiring harness externals.

Is the inspection result normal?

YES >> GO TO 3.

NO >> Repair or replace wiring harness.

**3.CHECK FRONT SEAT BELT PRE-TENSIONER**

1. Replace front LH seat belt pre-tensioner.

2. Check the screen of CONSULT-III.

Is the inspection result normal?

YES >> **INSPECTION END.**

NO >> Check the intermittent incident. Refer to [GI-40, "Intermittent Incident"](#).

A  
B  
C  
D  
E  
F  
G  
I  
J  
K  
L  
M  
N  
O  
P

SRC

**B1088 PRE-TEN FRONT LH**

**Description**

INFOID:000000005252721

**DTC B1088 [GND-SHORT] PRE-TEN FRONT LH**

For front LH seat belt pre-tensioner, crash is judged by main “G” sensor output signal and sub “G” sensor in front direction.

**OPERATION**

In the case of a frontal collision that exceeds specified impact level, the diagnosis sensor unit detects the deceleration caused by collision. If restrains the passenger with seat belt easing the stress on passengers chest with load limiter.

**STRUCTURE**

The restraint system for front seat occupant consists of the pre-tensioner mechanism and load limiter mechanism.

**INSTALLATION**

Front LH seat belt pre-tensioner is installed on the underside of center pillar with fixed nuts.

**DTC Logic**

INFOID:000000005252722

**DTC DETECTION LOGIC**

With CONSULT-III

DTC No. Index (“SELF-DIAG [CURRENT]”), (“SELF-DIAG [PAST]” or “TROUBLE DIAG RECORD”)

DTC No.	Trouble diagnosis name	DTC detecting condition	Possible cause
B1088	PRE-TEN FRONT LH [GND-SHORT]	Front LH seat belt pre-tensioner circuit is shorted to ground.	<ul style="list-style-type: none"> <li>• Disconnection of wiring harness and short.</li> <li>• Internal breakdown in front LH seat belt pre-tensioner.</li> <li>• Internal breakdown in diagnosis sensor unit (ACU).</li> </ul>

**DTC CONFIRMATION PROCEDURE (With CONSULT-III)**

**1.INSPECTION START**

Turn ignition switch ON.

>> GO TO 2.

**2.CHECK SELF-DIAG RESULT**

Check the screen of CONSULT-III.

Is malfunctioning part detected?

- YES >> Refer to [SRC-81. "Diagnosis Procedure"](#).
- NO >> **INSPECTION END.**

**DTC CONFIRMATION PROCEDURE (Without CONSULT-III)**

**NOTE:**

- SRS will not enter diagnosis mode if no malfunction is detected in user mode.

**1.INSPECTION START**

Turn ignition switch ON.



< DTC/CIRCUIT DIAGNOSIS >

>> GO TO 2.

2.CHECK AIR BAG WARNING LAMP

Check the warning lamp status.

Is malfunctioning part detected?

YES >> Refer to [SRC-154, "DTC Index"](#).

NO >> **INSPECTION END.**

Diagnosis Procedure

INFOID:000000005252723

With CONSULT-III

**WARNING:**

- Before servicing, turn ignition switch OFF, disconnect both battery terminals and wait at least 3 minutes. (To discharge backup capacitor.)
- Do not use unspecified tester or other measuring device.

DIAGNOSTIC PROCEDURE

1.CHECK HARNESS CONNECTOR

Check the connection of harness connector.

Is the inspection result normal?

YES >> GO TO 2.

NO >> Repair or replace harness connector.

2.CHECK WIRING HARNESS

Check the wiring harness externals.

Is the inspection result normal?

YES >> GO TO 3.

NO >> Replace wiring harness.

3.CHECK FRONT SEAT BELT PRE-TENSIONER

1. Replace front LH seat belt pre-tensioner.

2. Check the screen of CONSULT-III.

Is the inspection result normal?

YES >> **INSPECTION END.**

NO >> Check the intermittent incident. Refer to [GI-40, "Intermittent Incident"](#).

A  
B  
C  
D  
E  
F  
G  
I  
J  
K  
L  
M  
N  
O  
P

SRC

## B1089 PRE-TEN FRONT LH

### Description

INFOID:000000005252724

#### DTC B1089 [SHORT] PRE-TEN FRONT LH

For front LH seat belt pre-tensioner, crash is judged by main "G" sensor output signal and sub "G" sensor in front direction.

### OPERATION

In the case of a frontal collision that exceeds specified impact level, the diagnosis sensor unit detects the deceleration caused by collision. If restrains the passenger with seat belt easing the stress on passengers chest with load limiter.

### STRUCTURE

The restraint system for front seat occupant consists of the pre-tensioner mechanism and load limiter mechanism.

### INSTALLATION

Front LH seat belt pre-tensioner is installed on the underside of center pillar with fixed nuts.

### DTC Logic

INFOID:000000005252725

#### DTC DETECTION LOGIC

With CONSULT-III

DTC No. Index ("SELF-DIAG [CURRENT]"), ("SELF-DIAG [PAST]" or "TROUBLE DIAG RECORD")

DTC No.	Trouble diagnosis name	DTC detecting condition	Possible cause
B1089	PRE-TEN FRONT LH [SHORT]	Front LH seat belt pre-tensioner circuit are shorted to each other.	<ul style="list-style-type: none"><li>• Disconnection of wiring harness and short.</li><li>• Internal breakdown in front LH seat belt pre-tensioner.</li><li>• Internal breakdown in diagnosis sensor unit (ACU).</li></ul>

#### DTC CONFIRMATION PROCEDURE (With CONSULT-III)

##### 1.INSPECTION START

Turn ignition switch ON.

>> GO TO 2.

##### 2.CHECK SELF-DIAG RESULT

Check the screen of CONSULT-III.

Is malfunctioning part detected?

- YES >> Refer to [SRC-83. "Diagnosis Procedure"](#).
- NO >> **INSPECTION END.**

#### DTC CONFIRMATION PROCEDURE (Without CONSULT-III)

##### NOTE:

- SRS will not enter diagnosis mode if no malfunction is detected in user mode.

##### 1.INSPECTION START

Turn ignition switch ON.

< DTC/CIRCUIT DIAGNOSIS >

>> GO TO 2.

**2.CHECK AIR BAG WARNING LAMP**

Check the warning lamp status.

Is malfunctioning part detected?

YES >> Refer to [SRC-154, "DTC Index"](#).

NO >> **INSPECTION END.**

Diagnosis Procedure

INFOID:000000005252726

With CONSULT-III

**WARNING:**

- Before servicing, turn ignition switch OFF, disconnect both battery terminals and wait at least 3 minutes. (To discharge backup capacitor.)
- Do not use unspecified tester or other measuring device.

DIAGNOSTIC PROCEDURE

**1.CHECK HARNESS CONNECTOR**

Check the connection of harness connector.

Is the inspection result normal?

YES >> GO TO 2.

NO >> Repair or replace harness connector.

**2.CHECK WIRING HARNESS**

Check the wiring harness externals.

Is the inspection result normal?

YES >> GO TO 3.

NO >> Replace wiring harness.

**3.CHECK FRONT SEAT BELT PRE-TENSIONER**

1. Replace front LH seat belt pre-tensioner.

2. Check the screen of CONSULT-III.

Is the inspection result normal?

YES >> **INSPECTION END.**

NO >> Check the intermittent incident. Refer to [GI-40, "Intermittent Incident"](#).

A  
B  
C  
D  
E  
F  
G  
I  
J  
K  
L  
M  
N  
O  
P

SRC

# B1106, B1107, B1108, B1109, B1110, B1111 DIAGNOSIS SENSOR UNIT

< DTC/CIRCUIT DIAGNOSIS >

[FOR USA AND CANADA]

## B1106, B1107, B1108, B1109, B1110, B1111 DIAGNOSIS SENSOR UNIT

### Description

INFOID:000000005252727

#### DTC B1106, B1107, B1108, B1109, B1110, B1111 DIAGNOSIS SENSOR UNIT

Detects the whole SRS electrical system and displays the malfunction either by illuminating or blinking the air bag warning lamp in the combination meter. Malfunctioning part can be detected by on board self-diagnosis system and electro-diagnosis tester CONSULT-III.

### OPERATION

It detects a shock that exceeds specified level and monitors such systems as the driver and passenger air bag, side air bag, curtain air bag, pre-tensioner seat belts and Occupant Classification System (OCS) operate properly.

### STRUCTURE

It contains the "G" sensors for both frontal and side collisions and spare battery function in case of main battery damage in collision.

### INSTALLATION

SRS diagnosis sensor unit is installed under the center console with fixed bolts.

### DTC Logic

INFOID:000000005252728

### DTC DETECTION LOGIC

With CONSULT-III

DTC No. Index ("SELF-DIAG [CURRENT]"), ("SELF-DIAG [PAST]" or "TROUBLE DIAG RECORD")

DTC No.	Trouble diagnosis name	DTC detecting condition	Possible cause
B1106 B1107 B1108 B1109 B1110 B1111	CONTROL UNIT	Diagnosis sensor unit is out of order.	Internal breakdown in diagnosis sensor unit (ACU).

### DTC CONFIRMATION PROCEDURE (With CONSULT-III)

#### 1.INSPECTION START

Turn ignition switch ON.

>> GO TO 2.

#### 2.CHECK SELF-DIAG RESULT

Check the screen of CONSULT-III.

Is malfunctioning part detected?

- YES >> Refer to [SRC-85, "Diagnosis Procedure"](#).
- NO >> **INSPECTION END.**

### DTC CONFIRMATION PROCEDURE (Without CONSULT-III)

#### NOTE:

- SRS will not enter diagnosis mode if no malfunction is detected in user mode.

#### 1.INSPECTION START

Turn ignition switch ON.

# B1106, B1107, B1108, B1109, B1110, B1111 DIAGNOSIS SENSOR UNIT

< DTC/CIRCUIT DIAGNOSIS >

[FOR USA AND CANADA]

>> GO TO 2.

## 2.CHECK AIR BAG WARNING LAMP

Check the warning lamp status.

Is malfunctioning part detected?

YES >> Refer to [SRC-154, "DTC Index"](#).

NO >> **INSPECTION END.**

## Diagnosis Procedure

INFOID:000000005252729

With CONSULT-III

### **WARNING:**

- Before servicing, turn ignition switch OFF, disconnect both battery terminals and wait at least 3 minutes. (To discharge backup capacitor.)
- Do not use unspecified tester or other measuring device.

## DIAGNOSTIC PROCEDURE

### 1.CHECK HARNESS CONNECTOR

Check the connection of harness connector.

Is the inspection result normal?

YES >> GO TO 2.

NO >> Repair or replace harness connectors.

### 2.CHECK WIRING HARNESS

Check the wiring harness externals.

Is the inspection result normal?

YES >> GO TO 3.

NO >> Replace wiring harness.

### 3.CHECK DIAGNOSIS SENSOR UNIT

1. Replace diagnosis sensor unit (ACU).

2. Check the screen of CONSULT-III.

Is the inspection result normal?

YES >> **INSPECTION END.**

NO >> Check the intermittent incident. Refer to [GI-40, "Intermittent Incident"](#).

A  
B  
C  
D  
E  
F  
G  
H  
I  
J  
K  
L  
M  
N  
O  
P

SRC

# B1113, B1114 SATELLITE SENS RH

< DTC/CIRCUIT DIAGNOSIS >

[FOR USA AND CANADA]

## B1113, B1114 SATELLITE SENS RH

### Description

INFOID:000000005252730

#### DTC B1113, B1114 [UNIT FAIL] SATELLITE SENS RH

Main "G" sensor generates signal voltage, when it detects deceleration beyond the specified level by vehicle side collision.

### OPERATION

When ACU define the both signal voltage of the "G" sensor and the Safing sensor to be that of collision which exceeds specified level, the driving circuit switches on and feeds the electric ignitor of both the side air bag and curtain air bag.

### STRUCTURE

Integrated type of the G sensor element for side collision with output terminals for signal voltage.

### INSTALLATION

RH satellite sensor is installed at the underside of center pillar with fixed nuts.

### DTC Logic

INFOID:000000005252731

#### DTC DETECTION LOGIC

With CONSULT-III

DTC No. Index ("SELF-DIAG [CURRENT]"), ("SELF-DIAG [PAST]" or "TROUBLE DIAG RECORD")

DTC No.	Trouble diagnosis name	DTC detecting condition	Possible cause
B1113 B1114	SATELLITE SENS RH [UNIT FAIL]	RH satellite sensor is out of order.	<ul style="list-style-type: none"><li>• Disconnection of wiring harness.</li><li>• Internal breakdown in RH satellite sensor.</li><li>• Internal breakdown in diagnosis sensor unit (ACU).</li></ul>

#### DTC CONFIRMATION PROCEDURE (With CONSULT-III)

##### 1.INSPECTION START

Turn ignition switch ON.

>> GO TO 2.

##### 2.CHECK SELF-DIAG RESULT

Check the screen of CONSULT-III.

Is malfunctioning part detected?

- YES >> Refer to [SRC-87, "Diagnosis Procedure"](#).  
NO >> **INSPECTION END.**

#### DTC CONFIRMATION PROCEDURE (Without CONSULT-III)

##### NOTE:

- SRS will not enter diagnosis mode if no malfunction is detected in user mode.

##### 1.INSPECTION START

Turn ignition switch ON.

>> GO TO 2.

# B1113, B1114 SATELLITE SENS RH

< DTC/CIRCUIT DIAGNOSIS >

[FOR USA AND CANADA]

## 2.CHECK AIR BAG WARNING LAMP

Check the warning lamp status.

Is malfunctioning part detected?

YES >> Refer to [SRC-154, "DTC Index"](#).

NO >> **INSPECTION END.**

### Diagnosis Procedure

INFOID:000000005252732

With CONSULT-III

#### **WARNING:**

- Before servicing, turn ignition switch OFF, disconnect both battery terminals and wait at least 3 minutes. (To discharge backup capacitor.)
- Do not use unspecified tester or other measuring device.

### DIAGNOSTIC PROCEDURE

#### 1.CHECK HARNESS CONNECTOR

Check the connection of harness connector.

Is the inspection result normal?

YES >> GO TO 2.

NO >> Repair or replace harness connector.

#### 2.CHECK WIRING HARNESS

Check the wiring harness externals.

Is the inspection result normal?

YES >> GO TO 3.

NO >> Repair or replace wiring harness.

#### 3.CHECK SATELLITE SENSOR

1. Replace RH satellite sensor.

2. Check the screen of CONSULT-III.

Is the inspection result normal?

YES >> **INSPECTION END.**

NO >> Check the intermittent incident. Refer to [GI-40, "Intermittent Incident"](#).

A  
B  
C  
D  
E  
F  
G  
I  
J  
K  
L  
M  
N  
O  
P

SRC

# B1115, B1116 SATELLITE SENS RH

< DTC/CIRCUIT DIAGNOSIS >

[FOR USA AND CANADA]

## B1115, B1116 SATELLITE SENS RH

### Description

INFOID:000000005252733

#### DTC B1115, B1116 [COMM FAIL] SATELLITE SENS RH

Main "G" sensor generates signal voltage, when it detects deceleration beyond the specified level by vehicle side collision.

### OPERATION

When ACU defines both signal voltage of the "G" sensor and the Safing sensor to be that of collision which exceeds specified level, the driving circuit switches on and feeds the electric ignitor of both the side air bag and curtain air bag.

### STRUCTURE

Integrated type of the G sensor element for side collision with output terminals for signal voltage.

### INSTALLATION

RH satellite sensor is installed at the underside of center pillar with fixed nuts.

### DTC Logic

INFOID:000000005252734

#### DTC DETECTION LOGIC

With CONSULT-III

DTC No. Index ("SELF-DIAG [CURRENT]"), ("SELF-DIAG [PAST]" or "TROUBLE DIAG RECORD")

DTC No.	Trouble diagnosis name	DTC detecting condition	Possible cause
B1115 B1116	SATELLITE SENS RH [COMM FAIL] [UNMATCH]	RH satellite sensor is out of order.	<ul style="list-style-type: none"><li>• Disconnection of wiring harness.</li><li>• Internal breakdown in RH satellite sensor.</li><li>• Internal breakdown in diagnosis sensor unit (ACU).</li></ul>

#### DTC CONFIRMATION PROCEDURE (With CONSULT-III)

##### 1.INSPECTION START

Turn ignition switch ON.

>> GO TO 2.

##### 2.CHECK SELF-DIAG RESULT

Check the screen of CONSULT-III.

Is malfunctioning part detected?

- YES >> Refer to [SRC-89, "Diagnosis Procedure"](#).  
NO >> **INSPECTION END.**

#### DTC CONFIRMATION PROCEDURE (Without CONSULT-III)

##### NOTE:

- SRS will not enter diagnosis mode if no malfunction is detected in user mode.

##### 1.INSPECTION START

Turn ignition switch ON.

>> GO TO 2.



# B1115, B1116 SATELLITE SENS RH

< DTC/CIRCUIT DIAGNOSIS >

[FOR USA AND CANADA]

## 2.CHECK AIR BAG WARNING LAMP

Check the warning lamp status.

Is malfunctioning part detected?

- YES >> Refer to [SRC-154, "DTC Index"](#).
- NO >> **INSPECTION END.**

### Diagnosis Procedure

INFOID:000000005252735

With CONSULT-III

#### **WARNING:**

- Before servicing, turn ignition switch OFF, disconnect both battery terminals and wait at least 3 minutes. (To discharge backup capacitor.)
- Do not use unspecified tester or other measuring device.

### DIAGNOSTIC PROCEDURE

#### 1.CHECK HARNESS CONNECTOR

Check the connection of harness connector.

Is the inspection result normal?

- YES >> GO TO 2.
- NO >> Repair or replace harness connector.

#### 2.CHECK WIRING HARNESS

Check the wiring harness externals.

Is the inspection result normal?

- YES >> GO TO 3.
- NO >> Repair or replace wiring harness.

#### 3.CHECK SATELLITE SENSOR

1. Replace RH satellite sensor.
2. Check the screen of CONSULT-III.

Is the inspection result normal?

- YES >> **INSPECTION END.**
- NO >> Check the intermittent incident. Refer to [GI-40, "Intermittent Incident"](#).

A  
B  
C  
D  
E  
F  
G  
I  
J  
K  
L  
M  
N  
O  
P

SRC

# B1118, B1119 SATELLITE SENS LH

< DTC/CIRCUIT DIAGNOSIS >

[FOR USA AND CANADA]

## B1118, B1119 SATELLITE SENS LH

### Description

INFOID:000000005252736

#### DTC B1118, B1119 [UNIT FAIL] SATELLITE SENS LH

Main "G" sensor generates signal voltage, when it detects deceleration beyond the specified level by vehicle side collision.

### OPERATION

When ACU defines both signal voltage of the "G" sensor and the Safing sensor to be that of collision which exceeds specified level, the driving circuit switches on and feeds the electric ignitor of both the side air bag and curtain air bag.

### STRUCTURE

Integrated type of the G sensor element for side collision with output terminals for signal voltage.

### INSTALLATION

LH satellite sensor is installed at the underside of center pillar with fixed nuts.

### DTC Logic

INFOID:000000005252737

#### DTC DETECTION LOGIC

With CONSULT-III

DTC No. Index ("SELF-DIAG [CURRENT]"), ("SELF-DIAG [PAST]" or "TROUBLE DIAG RECORD")

DTC No.	Trouble diagnosis name	DTC detecting condition	Possible cause
B1118 B1119	SATELLITE SENS LH [UNIT FAIL]	LH satellite sensor is out of order.	<ul style="list-style-type: none"><li>• Disconnection of wiring harness.</li><li>• Internal breakdown in LH satellite sensor.</li><li>• Internal breakdown in diagnosis sensor unit (ACU).</li></ul>

#### DTC CONFIRMATION PROCEDURE (With CONSULT-III)

##### 1.INSPECTION START

Turn ignition switch ON.

>> GO TO 2.

##### 2.CHECK SELF-DIAG RESULT

Check the screen of CONSULT-III.

Is malfunctioning part detected?

- YES >> Refer to [SRC-91, "Diagnosis Procedure"](#).  
NO >> **INSPECTION END.**

#### DTC CONFIRMATION PROCEDURE (Without CONSULT-III)

##### NOTE:

- SRS will not enter diagnosis mode if no malfunction is detected in user mode.

##### 1.INSPECTION START

Turn ignition switch ON.

>> GO TO 2.

# B1118, B1119 SATELLITE SENS LH

< DTC/CIRCUIT DIAGNOSIS >

[FOR USA AND CANADA]

## 2.CHECK AIR BAG WARNING LAMP

Check the warning lamp status.

Is malfunctioning part detected?

- YES >> Refer to [SRC-154, "DTC Index"](#).
- NO >> **INSPECTION END.**

### Diagnosis Procedure

INFOID:000000005252738

With CONSULT-III

#### **WARNING:**

- Before servicing, turn ignition switch OFF, disconnect both battery terminals and wait at least 3 minutes. (To discharge backup capacitor.)
- Do not use unspecified tester or other measuring device.

### DIAGNOSTIC PROCEDURE

#### 1.CHECK HARNESS CONNECTOR

Check the connection of harness connector.

Is the inspection result normal?

- YES >> GO TO 2.
- NO >> Repair or replace harness connector.

#### 2.CHECK WIRING HARNESS

Check the wiring harness externals.

Is the inspection result normal?

- YES >> GO TO 3.
- NO >> Repair or replace wiring harness.

#### 3.CHECK SATELLITE SENSOR

1. Replace LH satellite sensor.
2. Check the screen of CONSULT-III.

Is the inspection result normal?

- YES >> **INSPECTION END.**
- NO >> Check the intermittent incident. Refer to [GI-40, "Intermittent Incident"](#).

A  
B  
C  
D  
E  
F  
G  
I  
J  
K  
L  
M  
N  
O  
P

SRC

# B1120, B1121 SATELLITE SENS LH

< DTC/CIRCUIT DIAGNOSIS >

[FOR USA AND CANADA]

## B1120, B1121 SATELLITE SENS LH

### Description

INFOID:000000005252739

#### DTC B1120, B1121 [COMM FAIL] SATELLITE SENS LH

Main "G" sensor generates signal voltage, when it detects deceleration beyond the specified level by vehicle side collision.

### OPERATION

When ACU defines both signal voltage of the "G" sensor and the Safing sensor to be that of collision which exceeds specified level, the driving circuit switches on and feeds the electric ignitor of both the side air bag and curtain air bag.

### STRUCTURE

Integrated type of the G sensor element for side collision with output terminals for signal voltage.

### INSTALLATION

LH satellite sensor is installed at the underside of center pillar with fixed nuts.

### DTC Logic

INFOID:000000005252740

#### DTC DETECTION LOGIC

With CONSULT-III

DTC No. Index ("SELF-DIAG [CURRENT]"), ("SELF-DIAG [PAST]" or "TROUBLE DIAG RECORD")

DTC No.	Trouble diagnosis name	DTC detecting condition	Possible cause
B1120 B1121	SATELLITE SENS LH [COMM FAIL] [UNMATCH]	LH satellite sens is out of order.	<ul style="list-style-type: none"><li>• Disconnection of wiring harness.</li><li>• Internal breakdown in LH satellite sens.</li><li>• Internal breakdown in diagnosis sensor unit (ACU).</li></ul>

#### DTC CONFIRMATION PROCEDURE (With CONSULT-III)

##### 1.INSPECTION START

Turn ignition switch ON.

>> GO TO 2.

##### 2.CHECK SELF-DIAG RESULT

Check the screen of CONSULT-III.

Is malfunctioning part detected?

- YES >> Refer to [SRC-93, "Diagnosis Procedure"](#).  
NO >> **INSPECTION END.**

#### DTC CONFIRMATION PROCEDURE (Without CONSULT-III)

##### NOTE:

- SRS will not enter diagnosis mode if no malfunction is detected in user mode.

##### 1.INSPECTION START

Turn ignition switch ON.

>> GO TO 2.

# B1120, B1121 SATELLITE SENS LH

< DTC/CIRCUIT DIAGNOSIS >

[FOR USA AND CANADA]

## 2.CHECK AIR BAG WARNING LAMP

Check the warning lamp status.

Is malfunctioning part detected?

- YES >> Refer to [SRC-154, "DTC Index"](#).
- NO >> **INSPECTION END.**

### Diagnosis Procedure

INFOID:000000005252741

With CONSULT-III

#### **WARNING:**

- Before servicing, turn ignition switch OFF, disconnect both battery terminals and wait at least 3 minutes. (To discharge backup capacitor.)
- Do not use unspecified tester or other measuring device.

### DIAGNOSTIC PROCEDURE

#### 1.CHECK HARNESS CONNECTOR

Check the connection of harness connector.

Is the inspection result normal?

- YES >> GO TO 2.
- NO >> Repair or replace harness connector.

#### 2.CHECK WIRING HARNESS

Check the wiring harness externals.

Is the inspection result normal?

- YES >> GO TO 3.
- NO >> Repair or replace wiring harness.

#### 3.CHECK SATELLITE SENSOR

1. Replace LH satellite sensor.
2. Check the screen of CONSULT-III.

Is the inspection result normal?

- YES >> **INSPECTION END.**
- NO >> Check the intermittent incident. Refer to [GI-40, "Intermittent Incident"](#).

A  
B  
C  
D  
E  
F  
G  
I  
J  
K  
L  
M  
N  
O  
P

SRC

# B1122, B1123, B1124, B1125, B1126, B1127 DIAGNOSIS SENSOR UNIT

< DTC/CIRCUIT DIAGNOSIS >

[FOR USA AND CANADA]

## B1122, B1123, B1124, B1125, B1126, B1127 DIAGNOSIS SENSOR UNIT

### Description

INFOID:000000005252742

#### DTC B1122, B1123, B1124, B1125, B1126, B1127 DIAGNOSIS SENSOR UNIT

Detects the whole SRS electrical system and displays the malfunction either by illuminating or blinking the air bag warning lamp in the combination meter. Malfunctioning part can be detected by on board self-diagnosis system and electro-diagnosis tester CONSULT-III.

### OPERATION

It detects a shock that exceeds specified level and monitors such systems as the driver and passenger air bag, side air bag, curtain air bag, pre-tensioner seat belts and Occupant Classification System (OCS) operate properly.

### STRUCTURE

It contains the "G" sensors for both frontal and side collisions and spare battery function in case of main battery damage in collision.

### INSTALLATION

SRS diagnosis sensor unit is installed under the center console with fixed bolts.

### DTC Logic

INFOID:000000005252743

### DTC DETECTION LOGIC

With CONSULT-III

DTC No. Index ("SELF-DIAG [CURRENT]"), ("SELF-DIAG [PAST]" or "TROUBLE DIAG RECORD")

DTC No.	Trouble diagnosis name	DTC detecting condition	Possible cause
B1122 B1123 B1124 B1125 B1126 B1127	CONTROL UNIT	Diagnosis sensor unit is out of order.	Internal breakdown in diagnosis sensor unit (ACU).

### DTC CONFIRMATION PROCEDURE (With CONSULT-III)

#### 1.INSPECTION START

Turn ignition switch ON.

>> GO TO 2.

#### 2.CHECK SELF-DIAG RESULT

Check the screen of CONSULT-III.

Is malfunctioning part detected?

- YES >> Refer to [SRC-95, "Diagnosis Procedure"](#).
- NO >> **INSPECTION END.**

### DTC CONFIRMATION PROCEDURE (Without CONSULT-III)

#### NOTE:

- SRS will not enter diagnosis mode if no malfunction is detected in user mode.

#### 1.INSPECTION START

Turn ignition switch ON.

# B1122, B1123, B1124, B1125, B1126, B1127 DIAGNOSIS SENSOR UNIT

< DTC/CIRCUIT DIAGNOSIS >

[FOR USA AND CANADA]

>> GO TO 2.

## 2.CHECK AIR BAG WARNING LAMP

Check the warning lamp status.

Is malfunctioning part detected?

YES >> Refer to [SRC-154, "DTC Index"](#).

NO >> **INSPECTION END.**

## Diagnosis Procedure

INFOID:000000005252744

With CONSULT-III

### **WARNING:**

- Before servicing, turn ignition switch OFF, disconnect both battery terminals and wait at least 3 minutes. (To discharge backup capacitor.)
- Do not use unspecified tester or other measuring device.

## DIAGNOSTIC PROCEDURE

### 1.CHECK HARNESS CONNECTOR

Check the connection of harness connector.

Is the inspection result normal?

YES >> GO TO 2.

NO >> Repair or replace harness connectors.

### 2.CHECK WIRING HARNESS

Check the wiring harness externals.

Is the inspection result normal?

YES >> GO TO 3.

NO >> Repair or replace wiring harness.

### 3.CHECK DIAGNOSIS SENSOR UNIT

1. Replace diagnosis sensor unit (ACU).

2. Check the screen of CONSULT-III.

Is the inspection result normal?

YES >> **INSPECTION END.**

NO >> Check the intermittent incident. Refer to [GI-40, "Intermittent Incident"](#).

A  
B  
C  
D  
E  
F  
G  
H  
I  
J  
K  
L  
M  
N  
O  
P

SRC

**B1129 SIDE MODULE RH**

**Description**

INFOID:000000005252745

**DTC B1129 [OPEN] SIDE MODULE RH**

For front RH side air bag module, crash is judged by main “G” sensor output signal (left side: left satellite sensor, right side: right satellite sensor) and sub “G” sensor (right and left GP in center unit).

**OPERATION**

In case of collision whose acceleration exceeds the specified level, the ignition materials are ignited by electric ignition system. The system burns and introduces the chemical reaction of gas generating materials to generate hot gases that flow into the air bag through a filter and expand the bag.

**STRUCTURE**

Front RH side air bag module mainly consists of air bag and inflator which inflates air bag.

**INSTALLATION**

Front RH side air bag module is installed on the side of front seat back with fixed nuts.

**DTC Logic**

INFOID:000000005252746

**DTC DETECTION LOGIC**

With CONSULT-III

DTC No. Index (“SELF-DIAG [CURRENT]”), (“SELF-DIAG [PAST]” or “TROUBLE DIAG RECORD”)

DTC No.	Trouble diagnosis name	DTC detecting condition	Possible cause
B1129	SIDE MODULE RH [OPEN]	Front RH side air bag module circuit is open.	<ul style="list-style-type: none"> <li>• Disconnection of wiring harness and open.</li> <li>• Internal breakdown in front RH side air bag module.</li> <li>• Internal breakdown in diagnosis sensor unit (ACU).</li> </ul>

**DTC CONFIRMATION PROCEDURE (With CONSULT-III)**

**1.INSPECTION START**

Turn ignition switch ON.

>> GO TO 2.

**2.CHECK SELF-DIAG RESULT**

Check the screen of CONSULT-III.

Is malfunctioning part detected?

- YES >> Refer to [SRC-97, "Diagnosis Procedure"](#).
- NO >> **INSPECTION END.**

**DTC CONFIRMATION PROCEDURE (Without CONSULT-III)**

**NOTE:**

- SRS will not enter diagnosis mode if no malfunction is detected in user mode.

**1.INSPECTION START**

Turn ignition switch ON.

>> GO TO 2.



< DTC/CIRCUIT DIAGNOSIS >

**2.CHECK AIR BAG WARNING LAMP**

Check the warning lamp status.

Is malfunctioning part detected?

- YES >> Refer to [SRC-154, "DTC Index"](#).
- NO >> **INSPECTION END.**

Diagnosis Procedure

INFOID:000000005252747

With CONSULT-III

**WARNING:**

- Before servicing, turn ignition switch OFF, disconnect both battery terminals and wait at least 3 minutes. (To discharge backup capacitor.)
- Do not use unspecified tester or other measuring device.

DIAGNOSTIC PROCEDURE

**1.CHECK HARNESS CONNECTOR**

Check the connection of harness connector.

Is the inspection result normal?

- YES >> GO TO 2.
- NO >> Repair or replace harness connector.

**2.CHECK WIRING HARNESS**

Check the wiring harness externals.

Is the inspection result normal?

- YES >> GO TO 3.
- NO >> Repair or replace wiring harness.

**3.CHECK FRONT SIDE AIR BAG MODULE**

1. Replace front RH side air bag module.
2. Check the screen of CONSULT-III.

Is the inspection result normal?

- YES >> **INSPECTION END.**
- NO >> Check the intermittent incident. Refer to [GI-40, "Intermittent Incident"](#).

A  
B  
C  
D  
E  
F  
G  
I  
J  
K  
L  
M  
N  
O  
P

SRC

B1130 SIDE MODULE RH

Description

INFOID:000000005252748

DTC B1130 [VB-SHORT] SIDE MODULE RH

For front RH side air bag module, crash is judged by main "G" sensor output signal (left side: left satellite sensor, right side: right satellite sensor) and sub "G" sensor (right and left GP in center unit).

OPERATION

In case of collision whose acceleration exceeds the specified level, the ignition materials are ignited by electric ignition system. The system burns and introduces the chemical reaction of gas generating materials to generate hot gases that flow into the air bag through a filter and expand the bag.

STRUCTURE

Front RH side air bag module mainly consists of air bag and inflator which inflates air bag.

INSTALLATION

Front RH side air bag module is installed on the side of front seatback with fixed nuts.

DTC Logic

INFOID:000000005252749

DTC DETECTION LOGIC

With CONSULT-III

DTC No. Index ("SELF-DIAG [CURRENT]"), ("SELF-DIAG [PAST]" or "TROUBLE DIAG RECORD")

DTC No.	Trouble diagnosis name	DTC detecting condition	Possible cause
B1130	SIDE MODULE RH [VB-SHORT]	Front RH side air bag module circuit is shorted to some power supply circuit.	<ul style="list-style-type: none"> <li>• Disconnection of wiring harness and short.</li> <li>• Internal breakdown in front RH side air bag module.</li> <li>• Internal breakdown in diagnosis sensor unit (ACU).</li> </ul>

DTC CONFIRMATION PROCEDURE (With CONSULT-III)

1.INSPECTION START

Turn ignition switch ON.

>> GO TO 2.

2.CHECK SELF-DIAG RESULT

Check the screen of CONSULT-III.

Is malfunctioning part detected?

- YES >> Refer to [SRC-99, "Diagnosis Procedure"](#).
- NO >> **INSPECTION END.**

DTC CONFIRMATION PROCEDURE (Without CONSULT-III)

NOTE:

- SRS will not enter diagnosis mode if no malfunction is detected in user mode.

1.INSPECTION START

Turn ignition switch ON.

>> GO TO 2.

< DTC/CIRCUIT DIAGNOSIS >

**2.CHECK AIR BAG WARNING LAMP**

Check the warning lamp status.

Is malfunctioning part detected?

- YES >> Refer to [SRC-154, "DTC Index"](#).
- NO >> **INSPECTION END.**

Diagnosis Procedure

INFOID:000000005252750

With CONSULT-III

**WARNING:**

- Before servicing, turn ignition switch OFF, disconnect both battery terminals and wait at least 3 minutes. (To discharge backup capacitor.)
- Do not use unspecified tester or other measuring device.

DIAGNOSTIC PROCEDURE

**1.CHECK HARNESS CONNECTOR**

Check the connection of harness connector.

Is the inspection result normal?

- YES >> GO TO 2.
- NO >> Repair or replace harness connector.

**2.CHECK WIRING HARNESS**

Check the wiring harness externals.

Is the inspection result normal?

- YES >> GO TO 3.
- NO >> Repair or replace wiring harness.

**3.CHECK FRONT SIDE AIR BAG MODULE**

1. Replace front RH side air bag module.
2. Check the screen of CONSULT-III.

Is the inspection result normal?

- YES >> **INSPECTION END.**
- NO >> Check the intermittent incident. Refer to [GI-40, "Intermittent Incident"](#).

A  
B  
C  
D  
E  
F  
G  
I  
J  
K  
L  
M  
N  
O  
P

SRC

**B1131 SIDE MODULE RH****Description**

INFOID:000000005252751

**DTC B1131 [GND-SHORT] SIDE MODULE RH**

For front RH side air bag module, crash is judged by main "G" sensor output signal (left side: left satellite sensor, right side: right satellite sensor) and sub "G" sensor (right and left GP in center unit).

**OPERATION**

In case of collision whose acceleration exceeds the specified level, the ignition materials are ignited by electric ignition system. The system burns and introduces the chemical reaction of gas generating materials to generate hot gases that flow into the air bag through a filter and expand the bag.

**STRUCTURE**

Front RH side air bag module mainly consists of air bag and inflator which inflates air bag.

**INSTALLATION**

Front RH side air bag module is installed on the side of front seatback with fixed nuts.

**DTC Logic**

INFOID:000000005252752

**DTC DETECTION LOGIC**

With CONSULT-III

DTC No. Index ("SELF-DIAG [CURRENT]"), ("SELF-DIAG [PAST]" or "TROUBLE DIAG RECORD")

DTC No.	Trouble diagnosis name	DTC detecting condition	Possible cause
B1131	SIDE MODULE RH [GND-SHORT]	Front RH side air bag module circuit is shorted to ground.	<ul style="list-style-type: none"> <li>• Disconnection of wiring harness and short.</li> <li>• Internal breakdown in front RH side air bag module.</li> <li>• Internal breakdown in diagnosis sensor unit (ACU).</li> </ul>

**DTC CONFIRMATION PROCEDURE (With CONSULT-III)****1.INSPECTION START**

Turn ignition switch ON.

>> GO TO 2.

**2.CHECK SELF-DIAG RESULT**

Check the screen of CONSULT-III.

Is malfunctioning part detected?

YES >> Refer to [SRC-101, "Diagnosis Procedure"](#).

NO >> **INSPECTION END.**

**DTC CONFIRMATION PROCEDURE (Without CONSULT-III)****NOTE:**

- SRS will not enter diagnosis mode if no malfunction is detected in user mode.

**1.INSPECTION START**

Turn ignition switch ON.

>> GO TO 2.

< DTC/CIRCUIT DIAGNOSIS >

**2.CHECK AIR BAG WARNING LAMP**

Check the warning lamp status.

Is malfunctioning part detected?

- YES >> Refer to [SRC-154, "DTC Index"](#).
- NO >> **INSPECTION END.**

Diagnosis Procedure

INFOID:000000005252753

With CONSULT-III

**WARNING:**

- Before servicing, turn ignition switch OFF, disconnect both battery terminals and wait at least 3 minutes. (To discharge backup capacitor.)
- Do not use unspecified tester or other measuring device.

DIAGNOSTIC PROCEDURE

**1.CHECK HARNESS CONNECTOR**

Check the connection of harness connector.

Is the inspection result normal?

- YES >> GO TO 2.
- NO >> Repair or replace harness connector.

**2.CHECK WIRING HARNESS**

Check the wiring harness externals.

Is the inspection result normal?

- YES >> GO TO 3.
- NO >> Repair or replace wiring harness.

**3.CHECK FRONT SIDE AIR BAG MODULE**

1. Replace front RH side air bag module.
2. Check the screen of CONSULT-III.

Is the inspection result normal?

- YES >> **INSPECTION END.**
- NO >> Check the intermittent incident. Refer to [GI-40, "Intermittent Incident"](#).

A  
B  
C  
D  
E  
F  
G  
I  
J  
K  
L  
M  
N  
O  
P

SRC

**B1132 SIDE MODULE RH**

**Description**

INFOID:000000005252754

**DTC B1132 [SHORT] SIDE MODULE RH**

For front RH side air bag module, crash is judged by main “G” sensor output signal (left side: left satellite sensor, right side: right satellite sensor) and sub “G” sensor (right and left GP in center unit).

**OPERATION**

In case of collision whose acceleration exceeds the specified level, the ignition materials are ignited by electric ignition system. The system burns and introduces the chemical reaction of gas generating materials to generate hot gases that flow into the air bag through a filter and expand the bag.

**STRUCTURE**

Front RH side air bag module mainly consists of air bag and inflator which inflates air bag.

**INSTALLATION**

Front RH side air bag module is installed on the side of front seatback with fixed nuts.

**DTC Logic**

INFOID:000000005252755

**DTC DETECTION LOGIC**

With CONSULT-III

DTC No. Index (“SELF-DIAG [CURRENT]”), (“SELF-DIAG [PAST]” or “TROUBLE DIAG RECORD”)

DTC No.	Trouble diagnosis name	DTC detecting condition	Possible cause
B1132	SIDE MODULE RH [SHORT]	Front RH side air bag module circuit are shorted to each other.	<ul style="list-style-type: none"> <li>• Disconnection of wiring harness and short.</li> <li>• Internal breakdown in front RH side air bag module.</li> <li>• Internal breakdown in diagnosis sensor unit (ACU).</li> </ul>

**DTC CONFIRMATION PROCEDURE (With CONSULT-III)**

**1.INSPECTION START**

Turn ignition switch ON.

>> GO TO 2.

**2.CHECK SELF-DIAG RESULT**

Check the screen of CONSULT-III.

Is malfunctioning part detected?

YES >> Refer to [SRC-103. "Diagnosis Procedure"](#).

NO >> **INSPECTION END.**

**DTC CONFIRMATION PROCEDURE (Without CONSULT-III)**

**NOTE:**

- SRS will not enter diagnosis mode if no malfunction is detected in user mode.

**1.INSPECTION START**

Turn ignition switch ON.

>> GO TO 2.

< DTC/CIRCUIT DIAGNOSIS >

**2.CHECK AIR BAG WARNING LAMP**

Check the warning lamp status.

Is malfunctioning part detected?

- YES >> Refer to [SRC-154, "DTC Index"](#).
- NO >> **INSPECTION END.**

Diagnosis Procedure

INFOID:000000005252756

With CONSULT-III

**WARNING:**

- Before servicing, turn ignition switch OFF, disconnect both battery terminals and wait at least 3 minutes. (To discharge backup capacitor.)
- Do not use unspecified tester or other measuring device.

DIAGNOSTIC PROCEDURE

**1.CHECK HARNESS CONNECTOR**

Check the connection of harness connector.

Is the inspection result normal?

- YES >> GO TO 2.
- NO >> Repair or replace harness connector.

**2.CHECK WIRING HARNESS**

Check the wiring harness externals.

Is the inspection result normal?

- YES >> GO TO 3.
- NO >> Repair or replace wiring harness.

**3.CHECK FRONT SIDE AIR BAG MODULE**

1. Replace front RH side air bag module.
2. Check the screen of CONSULT-III.

Is the inspection result normal?

- YES >> **INSPECTION END.**
- NO >> Check the intermittent incident. Refer to [GI-40, "Intermittent Incident"](#).

A  
B  
C  
D  
E  
F  
G  
I  
J  
K  
L  
M  
N  
O  
P

SRC

**B1134 SIDE MODULE LH**

**Description**

INFOID:000000005252757

**DTC B1134 [OPEN] SIDE MODULE LH**

For front LH side air bag module, crash is judged by main “G” sensor output signal (left side: left satellite sensor, right side: right satellite sensor) and sub “G” sensor (right and left GP in center unit).

**OPERATION**

In case of collision whose acceleration exceeds the specified level, the ignition materials are ignited by electric ignition system. The system burns and introduces the chemical reaction of gas generating materials to generate hot gases that flow into the air bag through a filter and expand the bag.

**STRUCTURE**

Front LH side air bag module mainly consists of air bag and inflator which inflates air bag.

**INSTALLATION**

Front LH side air bag module is installed on the side of front seatback with fixed nuts.

**DTC Logic**

INFOID:000000005252758

**DTC DETECTION LOGIC**

With CONSULT-III

DTC No. Index (“SELF-DIAG [CURRENT]”), (“SELF-DIAG [PAST]” or “TROUBLE DIAG RECORD”)

DTC No.	Trouble diagnosis name	DTC detecting condition	Possible cause
B1134	SIDE MODULE LH [OPEN]	Front LH side air bag module circuit is open.	<ul style="list-style-type: none"> <li>• Disconnection of wiring harness and open.</li> <li>• Internal breakdown in front LH side air bag module.</li> <li>• Internal breakdown in diagnosis sensor unit (ACU).</li> </ul>

**DTC CONFIRMATION PROCEDURE (With CONSULT-III)**

**1.INSPECTION START**

Turn ignition switch ON.

>> GO TO 2.

**2.CHECK SELF-DIAG RESULT**

Check the screen of CONSULT-III.

Is malfunctioning part detected?

YES >> Refer to [SRC-105, "Diagnosis Procedure"](#).

NO >> **INSPECTION END.**

**DTC CONFIRMATION PROCEDURE (Without CONSULT-III)**

**NOTE:**

- SRS will not enter diagnosis mode if no malfunction is detected in user mode.

**1.INSPECTION START**

Turn ignition switch ON.

>> GO TO 2.



&lt; DTC/CIRCUIT DIAGNOSIS &gt;

**2.CHECK AIR BAG WARNING LAMP**

Check the warning lamp status.

Is malfunctioning part detected?

- YES >> Refer to [SRC-154, "DTC Index"](#).  
 NO >> **INSPECTION END.**

## Diagnosis Procedure

INFOID:000000005252759

With CONSULT-III

**WARNING:**

- Before servicing, turn ignition switch OFF, disconnect both battery terminals and wait at least 3 minutes. (To discharge backup capacitor.)
- Do not use unspecified tester or other measuring device.

## DIAGNOSTIC PROCEDURE

**1.CHECK HARNESS CONNECTOR**

Check the connection of harness connector.

Is the inspection result normal?

- YES >> GO TO 2.  
 NO >> Repair or replace harness connector.

**2.CHECK WIRING HARNESS**

Check the wiring harness externals.

Is the inspection result normal?

- YES >> GO TO 3.  
 NO >> Replace wiring harness.

**3.CHECK FRONT SIDE AIR BAG MODULE**

1. Replace front LH side air bag module.
2. Check the screen of CONSULT-III.

Is the inspection result normal?

- YES >> **INSPECTION END.**  
 NO >> Check the intermittent incident. Refer to [GI-40, "Intermittent Incident"](#).

A  
B  
C  
D  
E  
F  
G  
I  
J  
K  
L  
M  
N  
O  
P

SRC

**B1135 SIDE MODULE LH**

**Description**

INFOID:000000005252760

**DTC B1135 [VB-SHORT] SIDE MODULE LH**

For front LH side air bag module, crash is judged by main "G" sensor output signal (left side: left satellite sensor, right side: right satellite sensor) and sub "G" sensor (right and left GP in center unit).

**OPERATION**

In case of collision whose acceleration exceeds the specified level, the ignition materials are ignited by electric ignition system. The system burns and introduces the chemical reaction of gas generating materials to generate hot gases that flow into the air bag through a filter and expand the bag.

**STRUCTURE**

Front LH side air bag module mainly consists of air bag and inflator which inflates air bag.

**INSTALLATION**

Front LH side air bag module is installed on the side of front seatback with fixed nuts.

**DTC Logic**

INFOID:000000005252761

**DTC DETECTION LOGIC**

With CONSULT-III

DTC No. Index ("SELF-DIAG [CURRENT]"), ("SELF-DIAG [PAST]" or "TROUBLE DIAG RECORD")

DTC No.	Trouble diagnosis name	DTC detecting condition	Possible cause
B1135	SIDE MODULE LH [VB-SHORT]	Front LH side air bag module circuit is shorted to some power supply circuit.	<ul style="list-style-type: none"> <li>• Disconnection of wiring harness and short.</li> <li>• Internal breakdown in front LH side air bag module.</li> <li>• Internal breakdown in diagnosis sensor unit (ACU).</li> </ul>

**DTC CONFIRMATION PROCEDURE (With CONSULT-III)**

**1.INSPECTION START**

Turn ignition switch ON.

>> GO TO 2.

**2.CHECK SELF-DIAG RESULT**

Check the screen of CONSULT-III.

Is malfunctioning part detected?

YES >> Refer to [SRC-107, "Diagnosis Procedure"](#).

NO >> **INSPECTION END.**

**DTC CONFIRMATION PROCEDURE (Without CONSULT-III)**

**NOTE:**

- SRS will not enter diagnosis mode if no malfunction is detected in user mode.

**1.INSPECTION START**

Turn ignition switch ON.

>> GO TO 2.

< DTC/CIRCUIT DIAGNOSIS >

**2.CHECK AIR BAG WARNING LAMP**

Check the warning lamp status.

Is malfunctioning part detected?

- YES >> Refer to [SRC-154, "DTC Index"](#).
- NO >> **INSPECTION END.**

Diagnosis Procedure

INFOID:000000005252762

With CONSULT-III

**WARNING:**

- Before servicing, turn ignition switch OFF, disconnect both battery terminals and wait at least 3 minutes. (To discharge backup capacitor.)
- Do not use unspecified tester or other measuring device.

DIAGNOSTIC PROCEDURE

**1.CHECK HARNESS CONNECTOR**

Check the connection of harness connector.

Is the inspection result normal?

- YES >> GO TO 2.
- NO >> Repair or replace harness connector.

**2.CHECK WIRING HARNESS**

Check the wiring harness externals.

Is the inspection result normal?

- YES >> GO TO 3.
- NO >> Repair or replace wiring harness.

**3.CHECK FRONT SIDE AIR BAG MODULE**

1. Replace front LH side air bag module.
2. Check the screen of CONSULT-III.

Is the inspection result normal?

- YES >> **INSPECTION END.**
- NO >> Check the intermittent incident. Refer to [GI-40, "Intermittent Incident"](#).

A  
B  
C  
D  
E  
F  
G  
I  
J  
K  
L  
M  
N  
O  
P

SRC

**B1136 SIDE MODULE LH**

**Description**

INFOID:000000005252763

**DTC B1136 [GND-SHORT] SIDE MODULE LH**

For front LH side air bag module, crash is judged by main "G" sensor output signal (left side: left satellite sensor, right side: right satellite sensor) and sub "G" sensor (right and left GP in center unit).

**OPERATION**

In case of collision whose acceleration exceeds the specified level, the ignition materials are ignited by electric ignition system. The system burns and introduces the chemical reaction of gas generating materials to generate hot gases that flow into the air bag through a filter and expand the bag.

**STRUCTURE**

Front LH side air bag module mainly consists of air bag and inflator which inflates air bag.

**INSTALLATION**

Front LH side air bag module is installed on the side of front seatback with fixed nuts.

**DTC Logic**

INFOID:000000005252764

**DTC DETECTION LOGIC**

With CONSULT-III

DTC No. Index ("SELF-DIAG [CURRENT]"), ("SELF-DIAG [PAST]" or "TROUBLE DIAG RECORD")

DTC No.	Trouble diagnosis name	DTC detecting condition	Possible cause
B1136	SIDE MODULE LH [GND-SHORT]	Front LH side air bag module circuit is shorted to ground.	<ul style="list-style-type: none"> <li>• Disconnection of wiring harness and short.</li> <li>• Internal breakdown in front LH side air bag module.</li> <li>• Internal breakdown in diagnosis sensor unit (ACU).</li> </ul>

**DTC CONFIRMATION PROCEDURE (With CONSULT-III)**

**1.INSPECTION START**

Turn ignition switch ON.

>> GO TO 2.

**2.CHECK SELF-DIAG RESULT**

Check the screen of CONSULT-III.

Is malfunctioning part detected?

YES >> Refer to [SRC-109. "Diagnosis Procedure"](#).

NO >> **INSPECTION END.**

**DTC CONFIRMATION PROCEDURE (Without CONSULT-III)**

**NOTE:**

- SRS will not enter diagnosis mode if no malfunction is detected in user mode.

**1.INSPECTION START**

Turn ignition switch ON.

>> GO TO 2.

< DTC/CIRCUIT DIAGNOSIS >

**2.CHECK AIR BAG WARNING LAMP**

Check the warning lamp status.

Is malfunctioning part detected?

- YES >> Refer to [SRC-154, "DTC Index"](#).
- NO >> **INSPECTION END.**

Diagnosis Procedure

INFOID:000000005252765

With CONSULT-III

**WARNING:**

- Before servicing, turn ignition switch OFF, disconnect both battery terminals and wait at least 3 minutes. (To discharge backup capacitor.)
- Do not use unspecified tester or other measuring device.

DIAGNOSTIC PROCEDURE

**1.CHECK HARNESS CONNECTOR**

Check the connection of harness connector.

Is the inspection result normal?

- YES >> GO TO 2.
- NO >> Repair or replace harness connector.

**2.CHECK WIRING HARNESS**

Check the wiring harness externals.

Is the inspection result normal?

- YES >> GO TO 3.
- NO >> Repair or replace wiring harness.

**3.CHECK FRONT SIDE AIR BAG MODULE**

1. Replace front LH side air bag module.
2. Check the screen of CONSULT-III.

Is the inspection result normal?

- YES >> **INSPECTION END.**
- NO >> Check the intermittent incident. Refer to [GI-40, "Intermittent Incident"](#).

A  
B  
C  
D  
E  
F  
G  
I  
J  
K  
L  
M  
N  
O  
P

SRC

**B1137 SIDE MODULE LH**

**Description**

INFOID:000000005252766

**DTC B1137 [SHORT] SIDE MODULE LH**

For front LH side air bag module, crash is judged by main “G” sensor output signal (left side: left satellite sensor, right side: right satellite sensor) and sub “G” sensor (right and left GP in center unit).

**OPERATION**

In case of collision whose acceleration exceeds the specified level, the ignition materials are ignited by electric ignition system. The system burns and introduces the chemical reaction of gas generating materials to generate hot gases that flow into the air bag through a filter and expand the bag.

**STRUCTURE**

Front LH side air bag module mainly consists of air bag and inflator which inflates air bag.

**INSTALLATION**

Front LH side air bag module is installed on the side of front seatback with fixed nuts.

**DTC Logic**

INFOID:000000005252767

**DTC DETECTION LOGIC**

With CONSULT-III

DTC No. Index (“SELF-DIAG [CURRENT]”), (“SELF-DIAG [PAST]” or “TROUBLE DIAG RECORD”)

DTC No.	Trouble diagnosis name	DTC detecting condition	Possible cause
B1137	SIDE MODULE LH [SHORT]	Front LH side air bag module circuit are shorted to each other.	<ul style="list-style-type: none"> <li>• Disconnection of wiring harness and short.</li> <li>• Internal breakdown in front LH side air bag module.</li> <li>• Internal breakdown in diagnosis sensor unit (ACU).</li> </ul>

**DTC CONFIRMATION PROCEDURE (With CONSULT-III)**

**1.INSPECTION START**

Turn ignition switch ON.

>> GO TO 2.

**2.CHECK SELF-DIAG RESULT**

Check the screen of CONSULT-III.

Is malfunctioning part detected?

YES >> Refer to [SRC-111, "Diagnosis Procedure"](#).

NO >> **INSPECTION END.**

**DTC CONFIRMATION PROCEDURE (Without CONSULT-III)**

**NOTE:**

- SRS will not enter diagnosis mode if no malfunction is detected in user mode.

**1.INSPECTION START**

Turn ignition switch ON.

>> GO TO 2.

< DTC/CIRCUIT DIAGNOSIS >

**2.CHECK AIR BAG WARNING LAMP**

Check the warning lamp status.

Is malfunctioning part detected?

- YES >> Refer to [SRC-154, "DTC Index"](#).
- NO >> **INSPECTION END.**

Diagnosis Procedure

INFOID:000000005252768

With CONSULT-III

**WARNING:**

- Before servicing, turn ignition switch OFF, disconnect both battery terminal and wait at least 3 minutes. (To discharge backup capacitor.)
- Do not use un specified tester or other measuring device.

DIAGNOSTIC PROCEDURE

**1.CHECK HARNESS CONNECTOR**

Check the connection of harness connector.

Is the inspection result normal?

- YES >> GO TO 2.
- NO >> Repair or replace harness connector.

**2.CHECK WIRING HARNESS**

Check the wiring harness externals.

Is the inspection result normal?

- YES >> GO TO 3.
- NO >> Repair or replace wiring harness.

**3.CHECK FRONT SIDE AIR BAG MODULE**

1. Replace front LH side air bag module.
2. Check the screen of CONSULT-III.

Is the inspection result normal?

- YES >> **INSPECTION END.**
- NO >> Check the intermittent incident. Refer to [GI-40, "Intermittent Incident"](#).

A  
B  
C  
D  
E  
F  
G  
I  
J  
K  
L  
M  
N  
O  
P

SRC

# B1138, B1139, B1140, B1141, B1142, B1143 DIAGNOSIS SENSOR UNIT

< DTC/CIRCUIT DIAGNOSIS >

[FOR USA AND CANADA]

## B1138, B1139, B1140, B1141, B1142, B1143 DIAGNOSIS SENSOR UNIT

### Description

INFOID:000000005252769

#### DTC B1138, B1139, B1140, B1141, B1142, B1143 DIAGNOSIS SENSOR UNIT

Detects the whole SRS electrical system and displays the malfunction either by illuminating or blinking the air bag warning lamp in the combination meter. Malfunctioning part can be detected by on board self-diagnosis system and electro-diagnosis tester CONSULT-III.

### OPERATION

It detects a shock that exceeds specified level and monitors such systems as the driver and passenger air bag, side air bag, curtain air bag, pre-tensioner seat belts and Occupant Classification System (OCS) operate properly.

### STRUCTURE

It contains the "G" sensors for both frontal and side collisions and spare battery function in case of main battery damage in collision.

### INSTALLATION

SRS diagnosis sensor unit is installed under the center console with fixed bolts.

### DTC Logic

INFOID:000000005252770

### DTC DETECTION LOGIC

With CONSULT-III

DTC No. Index ("SELF-DIAG [CURRENT]"), ("SELF-DIAG [PAST]" or "TROUBLE DIAG RECORD")

DTC No.	Trouble diagnosis name	DTC detecting condition	Possible cause
B1138 B1139 B1140 B1141 B1142 B1143	CONTROL UNIT	Diagnosis sensor unit is out of order.	Internal breakdown in diagnosis sensor unit (ACU).

### DTC CONFIRMATION PROCEDURE (With CONSULT-III)

#### 1.INSPECTION START

Turn ignition switch ON.

>> GO TO 2.

#### 2.CHECK SELF-DIAG RESULT

Check the screen of CONSULT-III.

Is malfunctioning part detected?

- YES >> Refer to [SRC-113, "Diagnosis Procedure"](#).
- NO >> **INSPECTION END.**

### DTC CONFIRMATION PROCEDURE (Without CONSULT-III)

#### NOTE:

- SRS will not enter diagnosis mode if no malfunction is detected in user mode.

#### 1.INSPECTION START

Turn ignition switch ON.



# B1138, B1139, B1140, B1141, B1142, B1143 DIAGNOSIS SENSOR UNIT

< DTC/CIRCUIT DIAGNOSIS >

[FOR USA AND CANADA]

>> GO TO 2.

## 2.CHECK AIR BAG WARNING LAMP

Check the warning lamp status.

Is malfunctioning part detected?

YES >> Refer to [SRC-154, "DTC Index"](#).

NO >> **INSPECTION END.**

## Diagnosis Procedure

INFOID:000000005252771

With CONSULT-III

### **WARNING:**

- Before servicing, turn ignition switch OFF, disconnect both battery terminals and wait at least 3 minutes. (To discharge backup capacitor.)
- Do not use unspecified tester or other measuring device.

## DIAGNOSTIC PROCEDURE

### 1.CHECK HARNESS CONNECTOR

Check the connection of harness connector.

Is the inspection result normal?

YES >> GO TO 2.

NO >> Repair or replace harness connectors.

### 2.CHECK WIRING HARNESS

Check the wiring harness externals.

Is the inspection result normal?

YES >> GO TO 3.

NO >> Replace wiring harness.

### 3.CHECK DIAGNOSIS SENSOR UNIT

1. Replace diagnosis sensor unit (ACU).

2. Check the screen of CONSULT-III.

Is the inspection result normal?

YES >> **INSPECTION END.**

NO >> Check the intermittent incident. Refer to [GI-40, "Intermittent Incident"](#).

A  
B  
C  
D  
E  
F  
G  
H  
I  
J  
K  
L  
M  
N  
O  
P

SRC

## B1145 CURTAIN MODULE RH

### Description

INFOID:000000005252772

#### DTC B1145 [OPEN] CURTAIN MODULE RH

For RH side curtain air bag module, crash is judged by main “G” sensor output signal (left side: left satellite sensor, right side: right satellite sensor) and sub “G” sensor (right and left GP in center unit).

### OPERATION

In case of collision whose acceleration exceeds the specified level, the ignition materials are ignited by electric ignition system. The system burns and introduces the chemical reaction of gas generating materials to generate hot gases that flow into the air bag through a filter and expand the bag.

### STRUCTURE

RH side curtain air bag module mainly consists of air bag and inflator which inflates air bag.

### INSTALLATION

RH side curtain air bag module is installed on the roof side with fixed bolts.

### DTC Logic

INFOID:000000005252773

#### DTC DETECTION LOGIC

With CONSULT-III

DTC No. Index (“SELF-DIAG [CURRENT]”), (“SELF-DIAG [PAST]” or “TROUBLE DIAG RECORD”)

DTC No.	Trouble diagnosis name	DTC detecting condition	Possible cause
B1145	CURTAIN MODULE RH [OPEN]	RH side curtain air bag module circuit is open.	<ul style="list-style-type: none"> <li>• Disconnection of wiring harness and open.</li> <li>• Internal breakdown in RH side curtain air bag module.</li> <li>• Replace diagnosis sensor unit (ACU).</li> </ul>

#### DTC CONFIRMATION PROCEDURE (With CONSULT-III)

##### 1.INSPECTION START

Turn ignition switch ON.

>> GO TO 2.

##### 2.CHECK SELF-DIAG RESULT

Check the screen of CONSULT-III.

Is malfunctioning part detected?

YES >> Refer to [SRC-115. "Diagnosis Procedure"](#).

NO >> **INSPECTION END.**

#### DTC CONFIRMATION PROCEDURE (Without CONSULT-III)

##### NOTE:

- SRS will not enter diagnosis mode if no malfunction is detected in user mode.

##### 1.INSPECTION START

Turn ignition switch ON.

>> GO TO 2.

# B1145 CURTAIN MODULE RH

[FOR USA AND CANADA]

< DTC/CIRCUIT DIAGNOSIS >

## 2.CHECK AIR BAG WARNING LAMP

Check the warning lamp status.

Is malfunctioning part detected?

- YES >> Refer to [SRC-154, "DTC Index"](#).  
NO >> **INSPECTION END.**

### Diagnosis Procedure

INFOID:000000005252774

With CONSULT-III

#### **WARNING:**

- Before servicing, turn ignition switch OFF, disconnect both battery terminals and wait at least 3 minutes. (To discharge backup capacitor.)
- Do not use unspecified tester or other measuring device.

### DIAGNOSTIC PROCEDURE

#### 1.CHECK HARNESS CONNECTOR

Check the connection of harness connector.

Is the inspection result normal?

- YES >> GO TO 2.  
NO >> Repair or replace harness connector.

#### 2.CHECK WIRING HARNESS

Check the wiring harness externals.

Is the inspection result normal?

- YES >> GO TO 3.  
NO >> Repair or replace wiring harness.

#### 3.CHECK SIDE CURTAIN AIR BAG MODULE

1. Replace RH side curtain air bag module.
2. Check the screen of CONSULT-III.

Is the inspection result normal?

- YES >> **INSPECTION END.**  
NO >> Check the intermittent incident. Refer to [GI-40, "Intermittent Incident"](#).

A  
B  
C  
D  
E  
F  
G  
I  
J  
K  
L  
M  
N  
O  
P

SRC

**B1146 CURTAIN MODULE RH**

**Description**

INFOID:000000005252775

**DTC B1146 [VB-SHORT] CURTAIN MODULE RH**

For RH side curtain air bag module, crash is judged by main “G” sensor output signal (left side: left satellite sensor, right side: right satellite sensor) and sub “G” sensor (right and left GP in center unit).

**OPERATION**

In case of collision whose acceleration exceeds the specified level, the ignition materials are ignited by electric ignition system. The system burns and introduces the chemical reaction of gas generating materials to generate hot gases that flow into the air bag through a filter and expand the bag.

**STRUCTURE**

RH side curtain air bag module mainly consists of air bag and inflator which inflates air bag.

**INSTALLATION**

RH side curtain air bag module is installed on the roof side with fixed bolts.

**DTC Logic**

INFOID:000000005252776

**DTC DETECTION LOGIC**

With CONSULT-III

DTC No. Index (“SELF-DIAG [CURRENT]”), (“SELF-DIAG [PAST]” or “TROUBLE DIAG RECORD”)

DTC No.	Trouble diagnosis name	DTC detecting condition	Possible cause
B1146	CURTAIN MODULE RH [VB-SHORT]	RH side curtain air bag module circuit is shorted to some power supply circuit.	<ul style="list-style-type: none"> <li>• Disconnection of wiring harness and short.</li> <li>• Internal breakdown in RH side curtain air bag module.</li> <li>• Internal breakdown in diagnosis sensor unit (ACU).</li> </ul>

**DTC CONFIRMATION PROCEDURE (With CONSULT-III)**

**1.INSPECTION START**

Turn ignition switch ON.

>> GO TO 2.

**2.CHECK SELF-DIAG RESULT**

Check the screen of CONSULT-III.

Is malfunctioning part detected?

YES >> Refer to [SRC-117. "Diagnosis Procedure"](#).

NO >> **INSPECTION END.**

**DTC CONFIRMATION PROCEDURE (Without CONSULT-III)**

**NOTE:**

- SRS will not enter diagnosis mode if no malfunction is detected in user mode.

**1.INSPECTION START**

Turn ignition switch ON.

>> GO TO 2.

# B1146 CURTAIN MODULE RH

[FOR USA AND CANADA]

< DTC/CIRCUIT DIAGNOSIS >

## 2.CHECK AIR BAG WARNING LAMP

Check the warning lamp status.

Is malfunctioning part detected?

- YES >> Refer to [SRC-154, "DTC Index"](#).  
NO >> **INSPECTION END.**

### Diagnosis Procedure

INFOID:000000005252777

With CONSULT-III

#### **WARNING:**

- Before servicing, turn ignition switch OFF, disconnect both battery terminals and wait at least 3 minutes. (To discharge backup capacitor.)
- Do not use unspecified tester or other measuring device.

### DIAGNOSTIC PROCEDURE

## 1.CHECK HARNESS CONNECTOR

Check the connection of harness connector.

Is the inspection result normal?

- YES >> GO TO 2.  
NO >> Repair or replace harness connector.

## 2.CHECK WIRING HARNESS

Check the wiring harness externals.

Is the inspection result normal?

- YES >> GO TO 3.  
NO >> Repair or replace wiring harness.

## 3.CHECK SIDE CURTAIN AIR BAG MODULE

1. Replace RH side curtain air bag module.
2. Check the screen of CONSULT-III.

Is the inspection result normal?

- YES >> **INSPECTION END.**  
NO >> Check the intermittent incident. Refer to [GI-40, "Intermittent Incident"](#).

A  
B  
C  
D  
E  
F  
G  
I  
J  
K  
L  
M  
N  
O  
P

SRC

## B1147 CURTAIN MODULE RH

### Description

INFOID:000000005252778

#### DTC B1147 [GND-SHORT] CURTAIN MODULE RH

For RH side curtain air bag module, crash is judged by main "G" sensor output signal (left side: left satellite sensor, right side: right satellite sensor) and sub "G" sensor (right and left GP in center unit).

### OPERATION

In case of collision whose acceleration exceeds the specified level, the ignition materials are ignited by electric ignition system. The system burns and introduces the chemical reaction of gas generating materials to generate hot gases that flow into the air bag through a filter and expand the bag.

### STRUCTURE

RH side curtain air bag module mainly consists of air bag and inflator which inflates air bag.

### INSTALLATION

RH side curtain air bag module is installed on the roof side with fixed bolts.

### DTC Logic

INFOID:000000005252779

#### DTC DETECTION LOGIC

With CONSULT-III

DTC No. Index ("SELF-DIAG [CURRENT]"), ("SELF-DIAG [PAST]" or "TROUBLE DIAG RECORD")

DTC No.	Trouble diagnosis name	DTC detecting condition	Possible cause
B1147	CURTAIN MODULE RH [GND-SHORT]	RH side curtain air bag module circuit is shorted to ground.	<ul style="list-style-type: none"><li>• Disconnection of wiring harness and short.</li><li>• Internal breakdown in RH side curtain air bag module.</li><li>• Replace diagnosis sensor unit (ACU).</li></ul>

#### DTC CONFIRMATION PROCEDURE (With CONSULT-III)

##### 1.INSPECTION START

Turn ignition switch ON.

>> GO TO 2.

##### 2.CHECK SELF-DIAG RESULT

Check the screen of CONSULT-III.

Is malfunctioning part detected?

YES >> Refer to [SRC-119. "Diagnosis Procedure"](#).

NO >> **INSPECTION END.**

#### DTC CONFIRMATION PROCEDURE (Without CONSULT-III)

##### NOTE:

- SRS will not enter diagnosis mode if no malfunction is detected in user mode.

##### 1.INSPECTION START

Turn ignition switch ON.

>> GO TO 2.

# B1147 CURTAIN MODULE RH

[FOR USA AND CANADA]

< DTC/CIRCUIT DIAGNOSIS >

## 2.CHECK AIR BAG WARNING LAMP

Check the warning lamp status.

Is malfunctioning part detected?

- YES >> Refer to [SRC-154, "DTC Index"](#).  
NO >> **INSPECTION END.**

### Diagnosis Procedure

INFOID:000000005252780

With CONSULT-III

#### **WARNING:**

- Before servicing, turn ignition switch OFF, disconnect both battery terminals and wait at least 3 minutes. (To discharge backup capacitor.)
- Do not use unspecified tester or other measuring device.

### DIAGNOSTIC PROCEDURE

#### 1.CHECK HARNESS CONNECTOR

Check the connection of harness connector.

Is the inspection result normal?

- YES >> GO TO 2.  
NO >> Repair or replace harness connector.

#### 2.CHECK WIRING HARNESS

Check the wiring harness externals.

Is the inspection result normal?

- YES >> GO TO 3.  
NO >> Repair or replace wiring harness.

#### 3.CHECK SIDE CURTAIN AIR BAG MODULE

1. Replace RH side curtain air bag module.
2. Check the screen of CONSULT-III.

Is the inspection result normal?

- YES >> **INSPECTION END.**  
NO >> Check the intermittent incident. Refer to [GI-40, "Intermittent Incident"](#).

A  
B  
C  
D  
E  
F  
G  
I  
J  
K  
L  
M  
N  
O  
P

SRC

## B1148 CURTAIN MODULE RH

### Description

INFOID:000000005252781

#### DTC B1148 [SHORT] CURTAIN MODULE RH

For RH side curtain air bag module, crash is judged by main “G” sensor output signal (left side: left satellite sensor, right side: right satellite sensor) and sub “G” sensor (right and left GP in center unit).

### OPERATION

In case of collision whose acceleration exceeds the specified level, the ignition materials are ignited by electric ignition system. The system burns and introduces the chemical reaction of gas generating materials to generate hot gases that flow into the air bag through a filter and expand the bag.

### STRUCTURE

RH side curtain air bag module mainly consists of air bag and inflator which inflates air bag.

### INSTALLATION

RH side curtain air bag module is installed on the roof side with fixed bolts.

### DTC Logic

INFOID:000000005252782

#### DTC DETECTION LOGIC

With CONSULT-III

DTC No. Index (“SELF-DIAG [CURRENT]”), (“SELF-DIAG [PAST]” or “TROUBLE DIAG RECORD”)

DTC No.	Trouble diagnosis name	DTC detecting condition	Possible cause
B1148	CURTAIN MODULE RH [SHORT]	RH side curtain air bag module circuit are shorted to each other.	<ul style="list-style-type: none"> <li>• Disconnection of wiring harness and short.</li> <li>• Internal breakdown in RH side curtain air bag module.</li> <li>• Internal breakdown in diagnosis sensor unit (ACU).</li> </ul>

#### DTC CONFIRMATION PROCEDURE (With CONSULT-III)

##### 1.INSPECTION START

Turn ignition switch ON.

>> GO TO 2.

##### 2.CHECK SELF-DIAG RESULT

Check the screen of CONSULT-III.

Is malfunctioning part detected?

YES >> Refer to [SRC-121, "Diagnosis Procedure"](#).

NO >> **INSPECTION END.**

#### DTC CONFIRMATION PROCEDURE (Without CONSULT-III)

##### NOTE:

- SRS will not enter diagnosis mode if no malfunction is detected in user mode.

##### 1.INSPECTION START

Turn ignition switch ON.

>> GO TO 2.



# B1148 CURTAIN MODULE RH

[FOR USA AND CANADA]

< DTC/CIRCUIT DIAGNOSIS >

## 2.CHECK AIR BAG WARNING LAMP

Check the warning lamp status.

Is malfunctioning part detected?

- YES >> Refer to [SRC-154, "DTC Index"](#).  
NO >> **INSPECTION END.**

### Diagnosis Procedure

INFOID:000000005252783

With CONSULT-III

#### **WARNING:**

- Before servicing, turn ignition switch OFF, disconnect both battery terminals and wait at least 3 minutes. (To discharge backup capacitor.)
- Do not use unspecified tester or other measuring device.

### DIAGNOSTIC PROCEDURE

#### 1.CHECK HARNESS CONNECTOR

Check the connection of harness connector.

Is the inspection result normal?

- YES >> GO TO 2.  
NO >> Repair or replace harness connector.

#### 2.CHECK WIRING HARNESS

Check the wiring harness externals.

Is the inspection result normal?

- YES >> GO TO 3.  
NO >> Repair or replace wiring harness.

#### 3.CHECK SIDE CURTAIN AIR BAG MODULE

1. Replace RH side curtain air bag module.
2. Check the screen of CONSULT-III.

Is the inspection result normal?

- YES >> **INSPECTION END.**  
NO >> Check the intermittent incident. Refer to [GI-40, "Intermittent Incident"](#).

A  
B  
C  
D  
E  
F  
G  
I  
J  
K  
L  
M  
N  
O  
P

SRC

## B1150 CURTAIN MODULE LH

### Description

INFOID:000000005252784

#### DTC B1150 [OPEN] CURTAIN MODULE LH

For LH side curtain air bag module, crash is judged by main "G" sensor output signal (left side: left satellite sensor, right side: right satellite sensor) and sub "G" sensor (right and left GP in center unit).

### OPERATION

In case of collision whose acceleration exceeds the specified level, the ignition materials are ignited by electric ignition system. The system burns and introduces the chemical reaction of gas generating materials to generate hot gases that flow into the air bag through a filter and expand the bag.

### STRUCTURE

LH side curtain air bag module mainly consists of air bag and inflator which inflates air bag.

### INSTALLATION

LH side curtain air bag module is installed on the roof side with fixed bolts.

### DTC Logic

INFOID:000000005252785

#### DTC DETECTION LOGIC

With CONSULT-III

DTC No. Index ("SELF-DIAG [CURRENT]"), ("SELF-DIAG [PAST]" or "TROUBLE DIAG RECORD")

DTC No.	Trouble diagnosis name	DTC detecting condition	Possible cause
B1150	CURTAIN MODULE LH [OPEN]	LH side curtain air bag module circuit is open.	<ul style="list-style-type: none"><li>• Disconnection of wiring harness and open.</li><li>• Internal breakdown in LH side curtain air bag module.</li><li>• Internal breakdown in diagnosis sensor unit (ACU).</li></ul>

#### DTC CONFIRMATION PROCEDURE (With CONSULT-III)

##### 1.INSPECTION START

Turn ignition switch ON.

>> GO TO 2.

##### 2.CHECK SELF-DIAG RESULT

Check the screen of CONSULT-III.

Is malfunctioning part detected?

YES >> Refer to [SRC-123. "Diagnosis Procedure"](#).

NO >> **INSPECTION END.**

#### DTC CONFIRMATION PROCEDURE (Without CONSULT-III)

##### NOTE:

- SRS will not enter diagnosis mode if no malfunction is detected in user mode.

##### 1.INSPECTION START

Turn ignition switch ON.

>> GO TO 2.

# B1150 CURTAIN MODULE LH

[FOR USA AND CANADA]

< DTC/CIRCUIT DIAGNOSIS >

## 2.CHECK AIR BAG WARNING LAMP

Check the warning lamp status.

Is malfunctioning part detected?

- YES >> Refer to [SRC-154, "DTC Index"](#).  
NO >> **INSPECTION END.**

### Diagnosis Procedure

INFOID:000000005252786

With CONSULT-III

#### **WARNING:**

- Before servicing, turn ignition switch OFF, disconnect both battery terminals and wait at least 3 minutes. (To discharge backup capacitor.)
- Do not use unspecified tester or other measuring device.

### DIAGNOSTIC PROCEDURE

#### 1.CHECK HARNESS CONNECTOR

Check the connection of harness connector.

Is the inspection result normal?

- YES >> GO TO 2.  
NO >> Repair or replace harness connector.

#### 2.CHECK WIRING HARNESS

Check the wiring harness externals.

Is the inspection result normal?

- YES >> GO TO 3.  
NO >> Repair or replace wiring harness.

#### 3.CHECK SIDE CURTAIN AIR BAG MODULE

1. Replace LH side curtain air bag module.
2. Check the screen of CONSULT-III.

Is the inspection result normal?

- YES >> **INSPECTION END.**  
NO >> Check the intermittent incident. Refer to [GI-40, "Intermittent Incident"](#).

A  
B  
C  
D  
E  
F  
G  
I  
J  
K  
L  
M  
N  
O  
P

SRC

## B1151 CURTAIN MODULE LH

### Description

INFOID:000000005252787

#### DTC B1151 [VB-SHORT] CURTAIN MODULE LH

For LH side curtain air bag module, crash is judged by main "G" sensor output signal (left side: left satellite sensor, right side: right satellite sensor) and sub "G" sensor (right and left GP in center unit).

### OPERATION

In case of collision whose acceleration exceeds the specified level, the ignition materials are ignited by electric ignition system. The system burns and introduces the chemical reaction of gas generating materials to generate hot gases that flow into the air bag through a filter and expand the bag.

### STRUCTURE

LH side curtain air bag module mainly consists of air bag and inflator which inflates air bag.

### INSTALLATION

LH side curtain air bag module is installed on the roof side with fixed bolts.

### DTC Logic

INFOID:000000005252788

#### DTC DETECTION LOGIC

With CONSULT-III

DTC No. Index ("SELF-DIAG [CURRENT]"), ("SELF-DIAG [PAST]" or "TROUBLE DIAG RECORD")

DTC No.	Trouble diagnosis name	DTC detecting condition	Possible cause
B1151	CURTAIN MODULE LH [VB-SHORT]	LH side curtain air bag module circuit is shorted to some power supply circuit.	<ul style="list-style-type: none"><li>• Disconnection of wiring harness and short.</li><li>• Internal breakdown in LH side curtain air bag module.</li><li>• Internal breakdown in diagnosis sensor unit (ACU).</li></ul>

#### DTC CONFIRMATION PROCEDURE (With CONSULT-III)

##### 1.INSPECTION START

Turn ignition switch ON.

>> GO TO 2.

##### 2.CHECK SELF-DIAG RESULT

Check the screen of CONSULT-III.

Is malfunctioning part detected?

YES >> Refer to [SRC-125, "Diagnosis Procedure"](#).

NO >> **INSPECTION END.**

#### DTC CONFIRMATION PROCEDURE (Without CONSULT-III)

##### NOTE:

- SRS will not enter diagnosis mode if no malfunction is detected in user mode.

##### 1.INSPECTION START

Turn ignition switch ON.

>> GO TO 2.

# B1151 CURTAIN MODULE LH

[FOR USA AND CANADA]

< DTC/CIRCUIT DIAGNOSIS >

## 2.CHECK AIR BAG WARNING LAMP

Check the warning lamp status.

Is malfunctioning part detected?

- YES >> Refer to [SRC-154, "DTC Index"](#).  
NO >> **INSPECTION END.**

### Diagnosis Procedure

INFOID:000000005252789

With CONSULT-III

#### **WARNING:**

- Before servicing, turn ignition switch OFF, disconnect both battery terminals and wait at least 3 minutes. (To discharge backup capacitor.)
- Do not use unspecified tester or other measuring device.

### DIAGNOSTIC PROCEDURE

#### 1.CHECK HARNESS CONNECTOR

Check the connection of harness connector.

Is the inspection result normal?

- YES >> GO TO 2.  
NO >> Repair or replace harness connector.

#### 2.CHECK WIRING HARNESS

Check the wiring harness externals.

Is the inspection result normal?

- YES >> GO TO 3.  
NO >> Repair or replace wiring harness.

#### 3.CHECK SIDE CURTAIN AIR BAG MODULE

1. Replace LH side curtain air bag module.
2. Check the screen of CONSULT-III.

Is the inspection result normal?

- YES >> **INSPECTION END.**  
NO >> Check the intermittent incident. Refer to [GI-40, "Intermittent Incident"](#).

A  
B  
C  
D  
E  
F  
G  
I  
J  
K  
L  
M  
N  
O  
P

SRC

## B1152 CURTAIN MODULE LH

### Description

INFOID:000000005252790

#### DTC B1152 [GND-SHORT] CURTAIN MODULE LH

For LH side curtain air bag module, crash is judged by main "G" sensor output signal (left side: left satellite sensor, right side: right satellite sensor) and sub "G" sensor (right and left GP in center unit).

### OPERATION

In case of collision whose acceleration exceeds the specified level, the ignition materials are ignited by electric ignition system. The system burns and introduces the chemical reaction of gas generating materials to generate hot gases that flow into the air bag through a filter and expand the bag.

### STRUCTURE

LH side curtain air bag module mainly consists of air bag and inflator which inflates air bag.

### INSTALLATION

LH side curtain air bag module is installed on the roof side with fixed bolts.

### DTC Logic

INFOID:000000005252791

#### DTC DETECTION LOGIC

With CONSULT-III

DTC No. Index ("SELF-DIAG [CURRENT]"), ("SELF-DIAG [PAST]" or "TROUBLE DIAG RECORD")

DTC No.	Trouble diagnosis name	DTC detecting condition	Possible cause
B1152	CURTAIN MODULE LH [GND-SHORT]	LH side curtain air bag module circuit is shorted to ground.	<ul style="list-style-type: none"><li>• Disconnection of wiring harness and short.</li><li>• Internal breakdown in LH side curtain airbag module.</li><li>• Internal breakdown in diagnosis sensor unit (ACU).</li></ul>

#### DTC CONFIRMATION PROCEDURE (With CONSULT-III)

##### 1.INSPECTION START

Turn ignition switch ON.

>> GO TO 2.

##### 2.CHECK SELF-DIAG RESULT

Check the screen of CONSULT-III.

Is malfunctioning part detected?

YES >> Refer to [SRC-127, "Diagnosis Procedure"](#).

NO >> **INSPECTION END.**

#### DTC CONFIRMATION PROCEDURE (Without CONSULT-III)

##### NOTE:

- SRS will not enter diagnosis mode if no malfunction is detected in user mode.

##### 1.INSPECTION START

Turn ignition switch ON.

>> GO TO 2.

# B1152 CURTAIN MODULE LH

[FOR USA AND CANADA]

< DTC/CIRCUIT DIAGNOSIS >

## 2.CHECK AIR BAG WARNING LAMP

Check the warning lamp status.

Is malfunctioning part detected?

- YES >> Refer to [SRC-154, "DTC Index"](#).  
NO >> **INSPECTION END.**

### Diagnosis Procedure

INFOID:000000005252792

With CONSULT-III

#### **WARNING:**

- Before servicing, turn ignition switch OFF, disconnect both battery terminals and wait at least 3 minutes. (To discharge backup capacitor.)
- Do not use unspecified tester or other measuring device.

### DIAGNOSTIC PROCEDURE

## 1.CHECK HARNESS CONNECTOR

Check the connection of harness connector.

Is the inspection result normal?

- YES >> GO TO 2.  
NO >> Repair or replace harness connector.

## 2.CHECK WIRING HARNESS

Check the wiring harness externals.

Is the inspection result normal?

- YES >> GO TO 3.  
NO >> Repair or replace wiring harness.

## 3.CHECK SIDE CURTAIN AIR BAG MODULE

1. Replace LH side curtain air bag module.
2. Check the screen of CONSULT-III.

Is the inspection result normal?

- YES >> **INSPECTION END.**  
NO >> Check the intermittent incident. Refer to [GI-40, "Intermittent Incident"](#).

A  
B  
C  
D  
E  
F  
G  
I  
J  
K  
L  
M  
N  
O  
P

SRC

## B1153 CURTAIN MODULE LH

### Description

INFOID:000000005252793

#### DTC B1153 [SHORT] CURTAIN MODULE LH

For LH side curtain air bag module, crash is judged by main "G" sensor output signal (left side: left satellite sensor, right side: right satellite sensor) and sub "G" sensor (right and left GP in center unit).

### OPERATION

In case of collision whose acceleration exceeds the specified level, the ignition materials are ignited by electric ignition system. The system burns and introduces the chemical reaction of gas generating materials to generate hot gases that flow into the air bag through a filter and expand the bag.

### STRUCTURE

LH side curtain air bag module mainly consists of air bag and inflator which inflates air bag.

### INSTALLATION

LH side curtain air bag module is installed on the roof side with fixed bolts.

### DTC Logic

INFOID:000000005252794

#### DTC DETECTION LOGIC

With CONSULT-III

DTC No. Index ("SELF-DIAG [CURRENT]"), ("SELF-DIAG [PAST]" or "TROUBLE DIAG RECORD")

DTC No.	Trouble diagnosis name	DTC detecting condition	Possible cause
B1153	CURTAIN MODULE LH [SHORT]	LH side curtain air bag module circuit are shorted to each other.	<ul style="list-style-type: none"><li>• Disconnection of wiring harness and short.</li><li>• Internal breakdown in LH side curtain air bag module.</li><li>• Internal breakdown in diagnosis sensor unit (ACU).</li></ul>

#### DTC CONFIRMATION PROCEDURE (With CONSULT-III)

##### 1.INSPECTION START

Turn ignition switch ON.

>> GO TO 2.

##### 2.CHECK SELF-DIAG RESULT

Check the screen of CONSULT-III.

Is malfunctioning part detected?

YES >> Refer to [SRC-129. "Diagnosis Procedure"](#).

NO >> **INSPECTION END.**

#### DTC CONFIRMATION PROCEDURE (Without CONSULT-III)

##### NOTE:

- SRS will not enter diagnosis mode if no malfunction is detected in user mode.

##### 1.INSPECTION START

Turn ignition switch ON.

>> GO TO 2.



# B1153 CURTAIN MODULE LH

[FOR USA AND CANADA]

< DTC/CIRCUIT DIAGNOSIS >

## 2.CHECK AIR BAG WARNING LAMP

Check the warning lamp status.

Is malfunctioning part detected?

- YES >> Refer to [SRC-154, "DTC Index"](#).  
NO >> **INSPECTION END.**

### Diagnosis Procedure

INFOID:000000005252795

With CONSULT-III

#### **WARNING:**

- Before servicing, turn ignition switch OFF, disconnect both battery terminals and wait at least 3 minutes. (To discharge backup capacitor.)
- Do not use unspecified tester or other measuring device.

### DIAGNOSTIC PROCEDURE

#### 1.CHECK HARNESS CONNECTOR

Check the connection of harness connector.

Is the inspection result normal?

- YES >> GO TO 2.  
NO >> Repair or replace harness connector.

#### 2.CHECK WIRING HARNESS

Check the wiring harness externals.

Is the inspection result normal?

- YES >> GO TO 3.  
NO >> Repair or replace wiring harness.

#### 3.CHECK SIDE CURTAIN AIR BAG MODULE

1. Replace LH side curtain air bag module.
2. Check the screen of CONSULT-III.

Is the inspection result normal?

- YES >> **INSPECTION END.**  
NO >> Check the intermittent incident. Refer to [GI-40, "Intermittent Incident"](#).

A  
B  
C  
D  
E  
F  
G  
I  
J  
K  
L  
M  
N  
O  
P

SRC

# B1170, B1171, B1172, B1173, B1174, B1175 DIAGNOSIS SENSOR UNIT

< DTC/CIRCUIT DIAGNOSIS >

[FOR USA AND CANADA]

## B1170, B1171, B1172, B1173, B1174, B1175 DIAGNOSIS SENSOR UNIT

### Description

INFOID:000000005252796

#### DTC B1170, B1171, B1172, B1173, B1174, B1175 DIAGNOSIS SENSOR UNIT

Detects the whole SRS electrical system and displays the malfunction either by illuminating or blinking the air bag warning lamp in the combination meter. Malfunctioning part can be detected by on board self-diagnosis system and electro-diagnosis tester CONSULT-III.

### OPERATION

It detects a shock that exceeds specified level and monitors such systems as the driver and passenger air bag, side air bag, curtain air bag, pre-tensioner seat belts and Occupant Classification System (OCS) operate properly.

### STRUCTURE

It contains the "G" sensors for both frontal and side collisions and spare battery function in case of main battery damage in collision.

### INSTALLATION

SRS diagnosis sensor unit is installed under the center console with fixed bolts.

### DTC Logic

INFOID:000000005252797

### DTC DETECTION LOGIC

With CONSULT-III

DTC No. Index ("SELF-DIAG [CURRENT]"), ("SELF-DIAG [PAST]" or "TROUBLE DIAG RECORD")

DTC No.	Trouble diagnosis name	DTC detecting condition	Possible cause
B1170 B1171 B1172 B1173 B1174 B1175	CONTROL UNIT	Diagnosis sensor unit is out of order.	Internal breakdown in diagnosis sensor unit (ACU).

### DTC CONFIRMATION PROCEDURE (With CONSULT-III)

#### 1.INSPECTION START

Turn ignition switch ON.

>> GO TO 2.

#### 2.CHECK SELF-DIAG RESULT

Check the screen of CONSULT-III.

Is malfunctioning part detected?

- YES >> Refer to [SRC-131, "Diagnosis Procedure"](#).
- NO >> **INSPECTION END.**

### DTC CONFIRMATION PROCEDURE (Without CONSULT-III)

#### NOTE:

SRS will not enter diagnosis mode if no malfunction is detected in user mode.

#### 1.INSPECTION START

Turn ignition switch ON.

# B1170, B1171, B1172, B1173, B1174, B1175 DIAGNOSIS SENSOR UNIT

< DTC/CIRCUIT DIAGNOSIS >

[FOR USA AND CANADA]

>> GO TO 2.

## 2.CHECK AIR BAG WARNING LAMP

Check the warning lamp status.

Is malfunctioning part detected?

YES >> Refer to [SRC-303, "DTC Index"](#).

NO >> **INSPECTION END.**

## Diagnosis Procedure

INFOID:000000005252798

With CONSULT-III

### **WARNING:**

- Before servicing, turn ignition switch OFF, disconnect both battery terminals and wait at least 3 minutes. (To discharge backup capacitor.)
- Do not use unspecified tester or other measuring device.

## DIAGNOSTIC PROCEDURE

### 1.CHECK HARNESS CONNECTOR

Check the connection of harness connector.

Is the inspection result normal?

YES >> GO TO 2.

NO >> Repair or replace harness connectors.

### 2.CHECK WIRING HARNESS

Check the wiring harness externals.

Is the inspection result normal?

YES >> GO TO 3.

NO >> Repair or replace wiring harness.

### 3.CHECK DIAGNOSIS SENSOR UNIT

1. Replace diagnosis sensor unit (ACU).

2. Check the screen of CONSULT-III.

Is the inspection result normal?

YES >> **INSPECTION END.**

NO >> Check the intermittent incident. Refer to [GI-40, "Intermittent Incident"](#).

A  
B  
C  
D  
E  
F  
G  
H  
I  
J  
K  
L  
M  
N  
O  
P

SRC

**B1177 PRE-TEN2 FRONT RH**

**Description**

INFOID:000000005252799

**DTC B1177 [OPEN] PRE-TEN2 FRONT RH**

For front RH seat belt pre-tensioner 2, crash is judged by main “G” sensor output signal and sub “G” sensor in front direction.

**OPERATION**

In the case of a frontal collision that exceeds specified impact level, the diagnosis sensor unit detects the deceleration caused by collision. If restrains the passenger with seat belt easing the stress on passengers chest with load limiter.

**STRUCTURE**

The restraint system for front seat occupant consists of the pre-tensioner mechanism and load limiter mechanism.

**INSTALLATION**

Front RH seat belt pre-tensioner 2 is installed on the underside of center pillar with fixed nuts.

**DTC Logic**

INFOID:000000005252800

**DTC DETECTION LOGIC**

With CONSULT-III

DTC No. Index (“SELF-DIAG [CURRENT]”), (“SELF-DIAG [PAST]” or “TROUBLE DIAG RECORD”)

DTC No.	Trouble diagnosis name	DTC detecting condition	Possible cause
B1177	PRE-TEN2 FRONT RH [OPEN]	Front RH seat belt pre-tensioner 2 circuit is open.	<ul style="list-style-type: none"> <li>• Disconnection of wiring harness and open.</li> <li>• Internal breakdown in front RH seat belt pre-tensioner 2.</li> <li>• Internal breakdown in diagnosis sensor unit (ACU).</li> </ul>

**DTC CONFIRMATION PROCEDURE (With CONSULT-III)**

**1.INSPECTION START**

Turn ignition switch ON.

>> GO TO 2.

**2.CHECK SELF-DIAG RESULT**

Check the screen of CONSULT-III.

Is malfunctioning part detected?

- YES >> Refer to [SRC-133. "Diagnosis Procedure"](#).
- NO >> **INSPECTION END.**

**DTC CONFIRMATION PROCEDURE (Without CONSULT-III)**

**NOTE:**

- SRS will not enter diagnosis mode if no malfunction is detected in user mode.

**1.INSPECTION START**

Turn ignition switch ON.

< DTC/CIRCUIT DIAGNOSIS >

>> GO TO 2.

**2.CHECK AIR BAG WARNING LAMP**

Check the warning lamp status.

Is malfunctioning part detected?

YES >> Refer to [SRC-303, "DTC Index"](#).

NO >> **INSPECTION END.**

Diagnosis Procedure

INFOID:000000005252801

With CONSULT-III

**WARNING:**

- Before servicing, turn ignition switch OFF, disconnect both battery terminals and wait at least 3 minutes. (To discharge backup capacitor.)
- Do not use unspecified tester or other measuring device.

DIAGNOSTIC PROCEDURE

**1.CHECK HARNESS CONNECTOR**

Check the connection of harness connector.

Is the inspection result normal?

YES >> GO TO 2.

NO >> Repair or replace harness connector.

**2.CHECK WIRING HARNESS**

Check the wiring harness externals.

Is the inspection result normal?

YES >> GO TO 3.

NO >> Repair or replace wiring harness.

**3.CHECK FRONT SEAT BELT PRE-TENSIONER 2**

1. Replace front RH seat belt pre-tensioner 2.

2. Check the screen of CONSULT-III.

Is the inspection result normal?

YES >> **INSPECTION END.**

NO >> Check the intermittent incident. Refer to [GI-40, "Intermittent Incident"](#).

A  
B  
C  
D  
E  
F  
G  
I  
J  
K  
L  
M  
N  
O  
P

SRC

**B1178 PRE-TEN2 FRONT RH**

**Description**

INFOID:000000005252802

**DTC B1178 [VB-SHORT] PRE-TEN2 FRONT RH**

For front RH seat belt pre-tensioner 2, crash is judged by main "G" sensor output signal and sub "G" sensor in front direction.

**OPERATION**

In the case of a frontal collision that exceeds specified impact level, the diagnosis sensor unit detects the deceleration caused by collision. If restrains the passenger with seat belt easing the stress on passengers chest with load limiter.

**STRUCTURE**

The restraint system for front seat occupant consists of the pre-tensioner mechanism and load limiter mechanism.

**INSTALLATION**

Front RH seat belt pre-tensioner 2 is installed on the underside of center pillar with fixed nuts.

**DTC Logic**

INFOID:000000005252803

**DTC DETECTION LOGIC**

With CONSULT-III

DTC No. Index ("SELF-DIAG [CURRENT]"), ("SELF-DIAG [PAST]" or "TROUBLE DIAG RECORD")

DTC No.	Trouble diagnosis name	DTC detecting condition	Possible cause
B1178	PRE-TEN2 FRONT RH [VB-SHORT]	Front RH seat belt pre-tensioner 2 circuit is shorted to some power supply circuit.	<ul style="list-style-type: none"> <li>• Disconnection of wiring harness and short.</li> <li>• Internal breakdown in front RH seat belt pre-tensioner 2.</li> <li>• Internal breakdown in diagnosis sensor unit (ACU).</li> </ul>

**DTC CONFIRMATION PROCEDURE (With CONSULT-III)**

**1.INSPECTION START**

Turn ignition switch ON.

>> GO TO 2.

**2.CHECK SELF-DIAG RESULT**

Check the screen of CONSULT-III.

Is malfunctioning part detected?

- YES >> Refer to [SRC-135. "Diagnosis Procedure"](#).
- NO >> **INSPECTION END.**

**DTC CONFIRMATION PROCEDURE (Without CONSULT-III)**

**NOTE:**

- SRS will not enter diagnosis mode if no malfunction is detected in user mode.

**1.INSPECTION START**

Turn ignition switch ON.

< DTC/CIRCUIT DIAGNOSIS >

>> GO TO 2.

2.CHECK AIR BAG WARNING LAMP

Check the warning lamp status.

Is malfunctioning part detected?

YES >> Refer to SRC-303, "DTC Index".

NO >> INSPECTION END.

Diagnosis Procedure

INFOID:000000005252804

With CONSULT-III

WARNING:

- Before servicing, turn ignition switch OFF, disconnect both battery terminals and wait at least 3 minutes. (To discharge backup capacitor.)
- Do not use unspecified tester or other measuring device.

DIAGNOSTIC PROCEDURE

1.CHECK HARNESS CONNECTOR

Check the connection of harness connector.

Is the inspection result normal?

YES >> GO TO 2.

NO >> Repair or replace harness connector.

2.CHECK WIRING HARNESS

Check the wiring harness externals.

Is the inspection result normal?

YES >> GO TO 3.

NO >> Repair or replace wiring harness.

3.CHECK FRONT SEAT BELT PRE-TENSIONER 2

1. Replace front RH seat belt pre-tensioner 2.

2. Check the screen of CONSULT-III.

Is the inspection result normal?

YES >> INSPECTION END.

NO >> Check the intermittent incident. Refer to GI-40, "Intermittent Incident".

A  
B  
C  
D  
E  
F  
G  
I  
J  
K  
L  
M  
N  
O  
P

SRC

**B1179 PRE-TEN2 FRONT RH**

**Description**

INFOID:000000005252805

**DTC B1179 [GND-SHORT] PRE-TEN2 FRONT RH**

For front RH seat belt pre-tensioner 2, crash is judged by main “G” sensor output signal and sub “G” sensor in front direction.

**OPERATION**

In the case of a frontal collision that exceeds specified impact level, the diagnosis sensor unit detects the deceleration caused by collision. If restrains the passenger with seat belt easing the stress on passengers chest with load limiter.

**STRUCTURE**

The restraint system for front seat occupant consists of the pre-tensioner mechanism and load limiter mechanism.

**INSTALLATION**

Front RH seat belt pre-tensioner 2 is installed on the underside of center pillar with fixed nuts.

**DTC Logic**

INFOID:000000005252806

**DTC DETECTION LOGIC**

With CONSULT-III

DTC No. Index (“SELF-DIAG [CURRENT]”), (“SELF-DIAG [PAST]” or “TROUBLE DIAG RECORD”)

DTC No.	Trouble diagnosis name	DTC detecting condition	Possible cause
B1179	PRE-TEN2 FRONT RH [GND-SHORT]	Front RH seat belt pre-tensioner 2 circuit is shorted to ground.	<ul style="list-style-type: none"> <li>• Disconnection of wiring harness and short.</li> <li>• Internal breakdown in front RH seat belt pre-tensioner 2.</li> <li>• Internal breakdown in diagnosis sensor unit (ACU).</li> </ul>

**DTC CONFIRMATION PROCEDURE (With CONSULT-III)**

**1.INSPECTION START**

Turn ignition switch ON.

>> GO TO 2.

**2.CHECK SELF-DIAG RESULT**

Check the screen of CONSULT-III.

Is malfunctioning part detected?

- YES >> Refer to [SRC-137. "Diagnosis Procedure"](#).
- NO >> **INSPECTION END.**

**DTC CONFIRMATION PROCEDURE (Without CONSULT-III)**

**NOTE:**

- SRS will not enter diagnosis mode if no malfunction is detected in user mode.

**1.INSPECTION START**

Turn ignition switch ON.



< DTC/CIRCUIT DIAGNOSIS >

>> GO TO 2.

**2.CHECK AIR BAG WARNING LAMP**

Check the warning lamp status.

Is malfunctioning part detected?

YES >> Refer to [SRC-303, "DTC Index"](#).

NO >> **INSPECTION END.**

Diagnosis Procedure

INFOID:000000005252807

With CONSULT-III

**WARNING:**

- Before servicing, turn ignition switch OFF, disconnect both battery terminals and wait at least 3 minutes. (To discharge backup capacitor.)
- Do not use unspecified tester or other measuring device.

DIAGNOSTIC PROCEDURE

**1.CHECK HARNESS CONNECTOR**

Check the connection of harness connector.

Is the inspection result normal?

YES >> GO TO 2.

NO >> Repair or replace harness connector.

**2.CHECK WIRING HARNESS**

Check the wiring harness externals.

Is the inspection result normal?

YES >> GO TO 3.

NO >> Repair or replace wiring harness.

**3.CHECK FRONT SEAT BELT PRE-TENSIONER 2**

1. Replace front RH seat belt pre-tensioner 2.

2. Check the screen of CONSULT-III.

Is the inspection result normal?

YES >> **INSPECTION END.**

NO >> Check the intermittent incident. Refer to [GI-40, "Intermittent Incident"](#).

A  
B  
C  
D  
E  
F  
G  
I  
J  
K  
L  
M  
N  
O  
P

SRC

**B1180 PRE-TEN2 FRONT RH****Description**

INFOID:000000005252808

**DTC B1180 [SHORT] PRE-TEN2 FRONT RH**

For front RH seat belt pre-tensioner 2, crash is judged by main "G" sensor output signal and sub "G" sensor in front direction.

**OPERATION**

In the case of a frontal collision that exceeds specified impact level, the diagnosis sensor unit detects the deceleration caused by collision. If restrains the passenger with seat belt easing the stress on passengers chest with load limiter.

**STRUCTURE**

The restraint system for front seat occupant consists of the pre-tensioner mechanism and load limiter mechanism.

**INSTALLATION**

Front RH seat belt pre-tensioner 2 is installed on the underside of center pillar with fixed nuts.

**DTC Logic**

INFOID:000000005252809

**DTC DETECTION LOGIC**

With CONSULT-III

DTC No. Index ("SELF-DIAG [CURRENT]"), ("SELF-DIAG [PAST]" or "TROUBLE DIAG RECORD")

DTC No.	Trouble diagnosis name	DTC detecting condition	Possible cause
B1180	PRE-TEN2 FRONT RH [SHORT]	Front RH seat belt pre-tensioner 2 circuit are shorted to each other.	<ul style="list-style-type: none"> <li>• Disconnection of wiring harness and short.</li> <li>• Internal breakdown in front RH seat belt pre-tensioner 2.</li> <li>• Internal breakdown in diagnosis sensor unit (ACU).</li> </ul>

**DTC CONFIRMATION PROCEDURE (With CONSULT-III)****1.INSPECTION START**

Turn ignition switch ON.

>> GO TO 2.

**2.CHECK SELF-DIAG RESULT**

Check the screen of CONSULT-III.

Is malfunctioning part detected?

- YES >> Refer to [SRC-139. "Diagnosis Procedure"](#).  
 NO >> **INSPECTION END.**

**DTC CONFIRMATION PROCEDURE (Without CONSULT-III)****NOTE:**

- SRS will not enter diagnosis mode if no malfunction is detected in user mode.

**1.INSPECTION START**

Turn ignition switch ON.

< DTC/CIRCUIT DIAGNOSIS >

>> GO TO 2.

2.CHECK AIR BAG WARNING LAMP

Check the warning lamp status.

Is malfunctioning part detected?

YES >> Refer to SRC-303, "DTC Index".

NO >> INSPECTION END.

Diagnosis Procedure

INFOID:000000005252810

With CONSULT-III

WARNING:

- Before servicing, turn ignition switch OFF, disconnect both battery terminals and wait at least 3 minutes. (To discharge backup capacitor.)
- Do not use unspecified tester or other measuring device.

DIAGNOSTIC PROCEDURE

1.CHECK HARNESS CONNECTOR

Check the connection of harness connector.

Is the inspectiion result normal?

YES >> GO TO 2.

NO >> Repair or replace harness connector.

2.CHECK WIRING HARNESS

Check the wiring harness externals.

Is the inspection result normal?

YES >> GO TO 3.

NO >> Repair or replace wiring harness.

3.CHECK FRONT SEAT BELT PRE-TENSIONER 2

1. Replace front RH seat belt pre-tensioner 2.

2. Check the screen of CONSULT-III.

Is the inspection result normal?

YES >> INSPECTION END.

NO >> Check the intermittent incident. Refer to GI-40, "Intermittent Incident".

A  
B  
C  
D  
E  
F  
G  
I  
J  
K  
L  
M  
N  
O  
P

SRC

## B1182 PRE-TEN2 FRONT LH

### Description

INFOID:000000005252811

#### DTC B1182 [OPEN] PRE-TEN2 FRONT LH

For front LH seat belt pre-tensioner 2, crash is judged by main “G” sensor output signal and sub “G” sensor in front direction.

### OPERATION

In the case of a frontal collision that exceeds specified impact level, the diagnosis sensor unit detects the deceleration caused by collision. If restrains the passenger with seat belt easing the stress on passengers chest with load limiter.

### STRUCTURE

The restraint system for front seat occupant consists of the pre-tensioner mechanism and load limiter mechanism.

### INSTALLATION

Front LH seat belt pre-tensioner 2 is installed on the underside of center pillar with fixed nuts.

### DTC Logic

INFOID:000000005252812

#### DTC DETECTION LOGIC

With CONSULT-III

DTC No. Index (“SELF-DIAG [CURRENT]”), (“SELF-DIAG [PAST]” or “TROUBLE DIAG RECORD”)

DTC No.	Trouble diagnosis name	DTC detecting condition	Possible cause
B1182	PRE-TEN2 FRONT LH [OPEN]	Front LH seat belt pre-tensioner 2 circuit is open.	<ul style="list-style-type: none"> <li>• Disconnection of wiring harness and open.</li> <li>• Internal breakdown in front LH seat belt pre-tensioner 2.</li> <li>• Internal breakdown in diagnosis sensor unit (ACU).</li> </ul>

#### DTC CONFIRMATION PROCEDURE (With CONSULT-III)

##### 1.INSPECTION START

Turn ignition switch ON.

>> GO TO 2.

##### 2.CHECK SELF-DIAG RESULT

Check the screen of CONSULT-III.

Is malfunctioning part detected?

- YES >> Refer to [SRC-141. "Diagnosis Procedure"](#).  
 NO >> **INSPECTION END.**

#### DTC CONFIRMATION PROCEDURE (Without CONSULT-III)

##### NOTE:

- SRS will not enter diagnosis mode if no malfunction is detected in user mode.

##### 1.INSPECTION START

Turn ignition switch ON.

< DTC/CIRCUIT DIAGNOSIS >

>> GO TO 2.

**2.CHECK AIR BAG WARNING LAMP**

Check the warning lamp status.

Is malfunctioning part detected?

YES >> Refer to [SRC-303, "DTC Index"](#).

NO >> **INSPECTION END.**

Diagnosis Procedure

INFOID:000000005252813

With CONSULT-III

**WARNING:**

- Before servicing, turn ignition switch OFF, disconnect both battery terminals and wait at least 3 minutes. (To discharge backup capacitor.)
- Do not use unspecified tester or other measuring device.

DIAGNOSTIC PROCEDURE

**1.CHECK HARNESS CONNECTOR**

Check the connection of harness connector.

Is the inspection result normal?

YES >> GO TO 2.

NO >> Repair or replace harness connector.

**2.CHECK WIRING HARNESS**

Check the wiring harness externals.

Is the inspection result normal?

YES >> GO TO 3.

NO >> Replace wiring harness.

**3.CHECK FRONT SEAT BELT PRE-TENSIONER 2**

1. Replace front LH seat belt pre-tensioner 2.

2. Check the screen of CONSULT-III.

Is the inspection result normal?

YES >> **INSPECTION END.**

NO >> Check the intermittent incident. Refer to [GI-40, "Intermittent Incident"](#).

A  
B  
C  
D  
E  
F  
G  
I  
J  
K  
L  
M  
N  
O  
P

SRC

**B1183 PRE-TEN2 FRONT LH**

**Description**

INFOID:000000005252814

**DTC B1183 [VB-SHORT] PRE-TEN2 FRONT LH**

For front LH seat belt pre-tensioner 2, crash is judged by main “G” sensor output signal and sub “G” sensor in front direction.

**OPERATION**

In the case of a frontal collision that exceeds specified impact level, the diagnosis sensor unit detects the deceleration caused by collision. If restrains the passenger with seat belt easing the stress on passengers chest with load limiter.

**STRUCTURE**

The restraint system for front seat occupant consists of the pre-tensioner mechanism and load limiter mechanism.

**INSTALLATION**

Front LH seat belt pre-tensioner 2 is installed on the underside of center pillar with fixed nuts.

**DTC Logic**

INFOID:000000005252815

**DTC DETECTION LOGIC**

With CONSULT-III

DTC No. Index (“SELF-DIAG [CURRENT]”), (“SELF-DIAG [PAST]” or “TROUBLE DIAG RECORD”)

DTC No.	Trouble diagnosis name	DTC detecting condition	Possible cause
B1183	PRE-TEN2 FRONT LH [VB-SHORT]	Front LH seat belt pre-tensioner 2 circuit is shorted to some power supply circuit.	<ul style="list-style-type: none"> <li>• Disconnection of wiring harness and short.</li> <li>• Internal breakdown in front LH seat belt pre-tensioner 2.</li> <li>• Internal breakdown in diagnosis sensor unit (ACU).</li> </ul>

**DTC CONFIRMATION PROCEDURE (With CONSULT-III)**

**1.INSPECTION START**

Turn ignition switch ON.

>> GO TO 2.

**2.CHECK SELF-DIAG RESULT**

Check the screen of CONSULT-III.

Is malfunctioning part detected?

- YES >> Refer to [SRC-143. "Diagnosis Procedure"](#).
- NO >> **INSPECTION END.**

**DTC CONFIRMATION PROCEDURE (Without CONSULT-III)**

**NOTE:**

- SRS will not enter diagnosis mode if no malfunction is detected in user mode.

**1.INSPECTION START**

Turn ignition switch ON.

< DTC/CIRCUIT DIAGNOSIS >

>> GO TO 2.

**2.CHECK AIR BAG WARNING LAMP**

Check the warning lamp status.

Is malfunctioning part detected?

YES >> Refer to [SRC-303, "DTC Index"](#).

NO >> **INSPECTION END.**

Diagnosis Procedure

INFOID:000000005252816

With CONSULT-III

**WARNING:**

- Before servicing, turn ignition switch OFF, disconnect both battery terminals and wait at least 3 minutes. (To discharge backup capacitor.)
- Do not use unspecified tester or other measuring device.

DIAGNOSTIC PROCEDURE

**1.CHECK HARNESS CONNECTOR**

Check the connection of harness connector.

Is the inspection result normal?

YES >> GO TO 2.

NO >> Repair or replace harness connector.

**2.CHECK WIRING HARNESS**

Check the wiring harness externals.

Is the inspection result normal?

YES >> GO TO 3.

NO >> Repair or replace wiring harness.

**3.CHECK FRONT SEAT BELT PRE-TENSIONER 2**

1. Replace front LH seat belt pre-tensioner 2.

2. Check the screen of CONSULT-III.

Is the inspection result normal?

YES >> **INSPECTION END.**

NO >> Check the intermittent incident. Refer to [GI-40, "Intermittent Incident"](#).

A  
B  
C  
D  
E  
F  
G  
I  
J  
K  
L  
M  
N  
O  
P

SRC

## B1184 PRE-TEN2 FRONT LH

### Description

INFOID:000000005252817

#### DTC B1184 [GND-SHORT] PRE-TEN2 FRONT LH

For front LH seat belt pre-tensioner 2, crash is judged by main “G” sensor output signal and sub “G” sensor in front direction.

### OPERATION

In the case of a frontal collision that exceeds specified impact level, the diagnosis sensor unit detects the deceleration caused by collision. If restrains the passenger with seat belt easing the stress on passengers chest with load limiter.

### STRUCTURE

The restraint system for front seat occupant consists of the pre-tensioner mechanism and load limiter mechanism.

### INSTALLATION

Front LH seat belt pre-tensioner 2 is installed on the underside of center pillar with fixed nuts.

### DTC Logic

INFOID:000000005252818

### DTC DETECTION LOGIC

With CONSULT-III

DTC No. Index (“SELF-DIAG [CURRENT]”), (“SELF-DIAG [PAST]” or “TROUBLE DIAG RECORD”)

DTC No.	Trouble diagnosis name	DTC detecting condition	Possible cause
B1184	PRE-TEN2 FRONT LH [GND-SHORT]	Front LH seat belt pre-tensioner 2 circuit is shorted to ground.	<ul style="list-style-type: none"><li>• Disconnection of wiring harness and short.</li><li>• Internal breakdown in front LH seat belt pre-tensioner 2.</li><li>• Internal breakdown in diagnosis sensor unit (ACU).</li></ul>

### DTC CONFIRMATION PROCEDURE (With CONSULT-III)

#### 1.INSPECTION START

Turn ignition switch ON.

>> GO TO 2.

#### 2.CHECK SELF-DIAG RESULT

Check the screen of CONSULT-III.

Is malfunctioning part detected?

- YES >> Refer to [SRC-145. "Diagnosis Procedure"](#).
- NO >> **INSPECTION END.**

### DTC CONFIRMATION PROCEDURE (Without CONSULT-III)

#### NOTE:

- SRS will not enter diagnosis mode if no malfunction is detected in user mode.

#### 1.INSPECTION START

Turn ignition switch ON.



< DTC/CIRCUIT DIAGNOSIS >

>> GO TO 2.

**2.CHECK AIR BAG WARNING LAMP**

Check the warning lamp status.

Is malfunctioning part detected?

YES >> Refer to [SRC-303, "DTC Index"](#).

NO >> **INSPECTION END.**

Diagnosis Procedure

INFOID:000000005252819

With CONSULT-III

**WARNING:**

- Before servicing, turn ignition switch OFF, disconnect both battery terminals and wait at least 3 minutes. (To discharge backup capacitor.)
- Do not use unspecified tester or other measuring device.

DIAGNOSTIC PROCEDURE

**1.CHECK HARNESS CONNECTOR**

Check the connection of harness connector.

Is the inspection result normal?

YES >> GO TO 2.

NO >> Repair or replace harness connector.

**2.CHECK WIRING HARNESS**

Check the wiring harness externals.

Is the inspection result normal?

YES >> GO TO 3.

NO >> Replace wiring harness.

**3.CHECK FRONT SEAT BELT PRE-TENSIONER 2**

1. Replace front LH seat belt pre-tensioner 2.

2. Check the screen of CONSULT-III.

Is the inspection result normal?

YES >> **INSPECTION END.**

NO >> Check the intermittent incident. Refer to [GI-40, "Intermittent Incident"](#).

A  
B  
C  
D  
E  
F  
G  
I  
J  
K  
L  
M  
N  
O  
P

SRC

**B1185 PRE-TEN2 FRONT LH**

**Description**

INFOID:000000005252820

**DTC B1185 [SHORT] PRE-TEN2 FRONT LH**

For front LH seat belt pre-tensioner 2, crash is judged by main “G” sensor output signal and sub “G” sensor in front direction.

**OPERATION**

In the case of a frontal collision that exceeds specified impact level, the diagnosis sensor unit detects the deceleration caused by collision. If restrains the passenger with seat belt easing the stress on passengers chest with load limiter.

**STRUCTURE**

The restraint system for front seat occupant consists of the pre-tensioner mechanism and load limiter mechanism.

**INSTALLATION**

Front LH seat belt pre-tensioner 2 is installed on the underside of center pillar with fixed nuts.

**DTC Logic**

INFOID:000000005252821

**DTC DETECTION LOGIC**

With CONSULT-III

DTC No. Index (“SELF-DIAG [CURRENT]”), (“SELF-DIAG [PAST]” or “TROUBLE DIAG RECORD”)

DTC No.	Trouble diagnosis name	DTC detecting condition	Possible cause
B1185	PRE-TEN2 FRONT LH [SHORT]	Front LH seat belt pre-tensioner 2 circuit are shorted to each other.	<ul style="list-style-type: none"> <li>• Disconnection of wiring harness and short.</li> <li>• Internal breakdown in front LH seat belt pre-tensioner 2.</li> <li>• Internal breakdown in diagnosis sensor unit (ACU).</li> </ul>

**DTC CONFIRMATION PROCEDURE (With CONSULT-III)**

**1.INSPECTION START**

Turn ignition switch ON.

>> GO TO 2.

**2.CHECK SELF-DIAG RESULT**

Check the screen of CONSULT-III.

Is malfunctioning part detected?

- YES >> Refer to [SRC-147. "Diagnosis Procedure"](#).
- NO >> **INSPECTION END.**

**DTC CONFIRMATION PROCEDURE (Without CONSULT-III)**

**NOTE:**

- SRS will not enter diagnosis mode if no malfunction is detected in user mode.

**1.INSPECTION START**

Turn ignition switch ON.

< DTC/CIRCUIT DIAGNOSIS >

>> GO TO 2.

**2.CHECK AIR BAG WARNING LAMP**

Check the warning lamp status.

Is malfunctioning part detected?

YES >> Refer to [SRC-303, "DTC Index"](#).

NO >> **INSPECTION END.**

Diagnosis Procedure

INFOID:000000005252822

With CONSULT-III

**WARNING:**

- Before servicing, turn ignition switch OFF, disconnect both battery terminals and wait at least 3 minutes. (To discharge backup capacitor.)
- Do not use unspecified tester or other measuring device.

DIAGNOSTIC PROCEDURE

**1.CHECK HARNESS CONNECTOR**

Check the connection of harness connector.

Is the inspection result normal?

YES >> GO TO 2.

NO >> Repair or replace harness connector.

**2.CHECK WIRING HARNESS**

Check the wiring harness externals.

Is the inspection result normal?

YES >> GO TO 3.

NO >> Replace wiring harness.

**3.CHECK FRONT SEAT BELT PRE-TENSIONER 2**

1. Replace front LH seat belt pre-tensioner 2.

2. Check the screen of CONSULT-III.

Is the inspection result normal?

YES >> **INSPECTION END.**

NO >> Check the intermittent incident. Refer to [GI-40, "Intermittent Incident"](#).

A  
B  
C  
D  
E  
F  
G  
I  
J  
K  
L  
M  
N  
O  
P

SRC

# B1202, B1203, B1204, B1205, B1206, B1207 DIAGNOSIS SENSOR UNIT

< DTC/CIRCUIT DIAGNOSIS >

[FOR USA AND CANADA]

## B1202, B1203, B1204, B1205, B1206, B1207 DIAGNOSIS SENSOR UNIT

### Description

INFOID:000000005252823

#### DTC B1202, B1203, B1204, B1205, B1206, B1207 DIAGNOSIS SENSOR UNIT

Detects the whole SRS electrical system and displays the malfunction either by illuminating or blinking the air bag warning lamp in the combination meter. Malfunctioning part can be detected by on board self-diagnosis system and electro-diagnosis tester CONSULT-III.

### OPERATION

It detects a shock that exceeds specified level and monitors such systems as the driver and passenger air bag, side air bag, curtain air bag, pre-tensioner seat belts and Occupant Classification System (OCS) operate properly.

### STRUCTURE

It contains the "G" sensors for both frontal and side collisions and spare battery function in case of main battery damage in collision.

### INSTALLATION

SRS diagnosis sensor unit is installed under the center console with fixed bolts.

### DTC Logic

INFOID:000000005252824

### DTC DETECTION LOGIC

With CONSULT-III

DTC No. Index ("SELF-DIAG [CURRENT]"), ("SELF-DIAG [PAST]" or "TROUBLE DIAG RECORD")

DTC No.	Trouble diagnosis name	DTC detecting condition	Possible cause
B1202 B1203 B1204 B1205 B1206 B1207	CONTROL UNIT	Diagnosis sensor unit is out of order.	Internal breakdown in diagnosis sensor unit (ACU).

### DTC CONFIRMATION PROCEDURE (With CONSULT-III)

#### 1.INSPECTION START

Turn ignition switch ON.

>> GO TO 2.

#### 2.CHECK SELF-DIAG RESULT

Check the screen of CONSULT-III.

Is malfunctioning part detected?

- YES >> Refer to [SRC-149, "Diagnosis Procedure"](#).
- NO >> **INSPECTION END.**

### DTC CONFIRMATION PROCEDURE (Without CONSULT-III)

#### NOTE:

- SRS will not enter diagnosis mode if no malfunction is detected in user mode.

#### 1.INSPECTION START

Turn ignition switch ON.

# B1202, B1203, B1204, B1205, B1206, B1207 DIAGNOSIS SENSOR UNIT

< DTC/CIRCUIT DIAGNOSIS >

[FOR USA AND CANADA]

>> GO TO 2.

## 2.CHECK AIR BAG WARNING LAMP

Check the warning lamp status.

Is malfunctioning part detected?

YES >> Refer to [SRC-154, "DTC Index"](#).

NO >> **INSPECTION END.**

## Diagnosis Procedure

INFOID:000000005252825

With CONSULT-III

### **WARNING:**

- Before servicing, turn ignition switch OFF, disconnect both battery terminals and wait at least 3 minutes. (To discharge backup capacitor.)
- Do not use unspecified tester or other measuring device.

## DIAGNOSTIC PROCEDURE

### 1.CHECK HARNESS CONNECTOR

Check the connection of harness connector.

Is the inspection result normal?

YES >> GO TO 2.

NO >> Repair or replace harness connectors.

### 2.CHECK WIRING HARNESS

Check the wiring harness externals.

Is the inspection result normal?

YES >> GO TO 3.

NO >> Repair or replace wiring harness.

### 3.CHECK DIAGNOSIS SENSOR UNIT

1. Replace diagnosis sensor unit (ACU).

2. Check the screen of CONSULT-III.

Is the inspection result normal?

YES >> **INSPECTION END.**

NO >> Check the intermittent incident. Refer to [GI-40, "Intermittent Incident"](#).

A  
B  
C  
D  
E  
F  
G  
H  
I  
J  
K  
L  
M  
N  
O  
P

SRC

# B1209 FRONTAL COLLISION DETECTION

< DTC/CIRCUIT DIAGNOSIS >

[FOR USA AND CANADA]

## B1209 FRONTAL COLLISION DETECTION

### Description

INFOID:000000005252826

#### DTC B1209 FRONTAL COLLISION DETECTION

Detects component damage resulting from a front collision, blinks or illuminates the air bag warning lamp to inform the driver. Malfunctioning part can be detected by the CONSULT-III.

#### OPERATION

The air bag and seat belt pre-tensioners for driver and front seat passenger are operated by the decision of the diagnosis sensor unit (ACU) out signal transmitted because of the frontal collision.

#### STRUCTURE

It consists of crash zone sensor, diagnosis sensor unit (ACU), air bags and seat belt pre-tensioners for driver and front passenger.

#### INSTALLATION

Refer to [SR-20, "Removal and Installation"](#), [SR-24, "Removal and Installation"](#), [SR-11, "Removal and Installation"](#), [SR-16, "Removal and Installation"](#), [SB-7, "SEAT BELT RETRACTOR : Removal and Installation"](#).

### DTC Logic

INFOID:000000005252827

#### DTC DETECTION LOGIC

With CONSULT-III

DTC No. Index ("SELF-DIAG [CURRENT]"), ("SELF-DIAG [PAST]" or "TROUBLE DIAG RECORD")

DTC No.	Trouble diagnosis name	DTC detecting condition	Possible cause
B1209	FRONTAL COLLISION DETECTION	Front seat belt pre-tensioner, front air bag is deployed.	—

#### DTC CONFIRMATION PROCEDURE (With CONSULT-III)

##### 1.INSPECTION START

Turn ignition switch ON.

>> GO TO 2.

##### 2.CHECK SELF-DIAG RESULT

Check the screen of CONSULT-III.

Is malfunctioning part detected?

- YES >> Refer to [SRC-150, "Diagnosis Procedure"](#).
- NO >> **INSPECTION END.**

### Diagnosis Procedure

INFOID:000000005511348

#### **WARNING:**

- Before servicing, turn ignition switch OFF, disconnect battery negative terminal, and wait at least 3 minutes or more. (To discharge backup capacitor.)
- Never use unspecified tester or other measuring device.

##### 1.PERFORM COLLISION DIAGNOSIS

Perform collision diagnosis.Refer to [SR-5, "FOR FRONTAL COLLISION : When SRS is activated in a collision"](#) or [SR-6, "FOR FRONTAL COLLISION : When SRS is not activated in a collision"](#).

Is collision diagnosis complete?

- YES >> GO TO 2.

# B1209 FRONTAL COLLISION DETECTION

< DTC/CIRCUIT DIAGNOSIS >

[FOR USA AND CANADA]

NO >> INSPECTION END

## 2.FINAL INSPECTION

Perform "AIR BAG" Self Diagnostic Result.

Is the inspection result normal?

YES >> INSPECTION END

NO >> Perform diagnosis of applicable DTC.Refer to [SRC-154, "DTC Index"](#).

A

B

C

D

E

F

G

SRC

I

J

K

L

M

N

O

P

# B1210 SIDE COLLISION DETECTION

< DTC/CIRCUIT DIAGNOSIS >

[FOR USA AND CANADA]

## B1210 SIDE COLLISION DETECTION

### Description

INFOID:000000005252829

#### DTC B1210 SIDE COLLISION DETECTION

Detects component damage resulting from a side collision, brinks or illuminates the air bag warning lamp to inform the driver. Malfunctioning part can be detected by the CONSULT-III.

#### OPERATION

The side air bag and curtain air bag are operated by the decision of the diagnosis sensor unit (ACU) signal of the side collision.

#### STRUCTURE

It consists of satellite sensor, diagnosis sensor unit (ACU), front side air bag and side curtain air bag.

#### INSTALLATION

Refer to [SR-22. "Removal and Installation"](#), [SR-24. "Removal and Installation"](#), [SR-18. "Removal and Installation"](#).

### DTC Logic

INFOID:000000005252830

#### DTC DETECTION LOGIC

With CONSULT-III

DTC No. Index ("SELF-DIAG [CURRENT]"), ("SELF-DIAG [PAST]" or "TROUBLE DIAG RECORD")

DTC No.	Trouble diagnosis name	DTC detecting condition	Possible cause
B1210	SIDE COLLISION DETECTION	Front side air bag, side curtain air bag is deployed.	—

#### DTC CONFIRMATION PROCEDURE (With CONSULT-III)

##### 1.INSPECTION START

Turn ignition switch ON.

>> GO TO 2.

##### 2.CHECK SELF-DIAG RESULT

Check the screen of CONSULT-III.

Is malfunctioning part detected?

YES >> Refer to [SRC-152. "Diagnosis Procedure"](#).

NO >> **INSPECTION END.**

### Diagnosis Procedure

INFOID:000000005511349

#### **WARNING:**

- Before servicing, turn ignition switch OFF, disconnect battery negative terminal, and wait at least 3 minutes or more. (To discharge backup capacitor.)
- Never use unspecified tester or other measuring device.

##### 1.PERFORM COLLISION DIAGNOSIS

Perform collision diagnosis.Refer to [SR-5. "FOR FRONTAL COLLISION : When SRS is activated in a collision"](#) or [SR-6. "FOR FRONTAL COLLISION : When SRS is not activated in a collision"](#).

Is collision diagnosis complete?

YES >> GO TO 2.

NO >> **INSPECTION END**



# B1210 SIDE COLLISION DETECTION

< DTC/CIRCUIT DIAGNOSIS >

[FOR USA AND CANADA]

## 2. FINAL INSPECTION

Perform "AIR BAG" Self Diagnostic Result.

Is the inspection result normal?

YES >> INSPECTION END

NO >> Perform diagnosis of applicable DTC. Refer to [SRC-154. "DTC Index"](#).

A  
B  
C  
D  
E  
F  
G  
I  
J  
K  
L  
M  
N  
O  
P

SRC

# ECU DIAGNOSIS INFORMATION

## DIAGNOSIS SENSOR UNIT

### DTC Index

INFOID:000000005252832

DTC No. Index (With CONSULT-III)

("SELF-DIAG [CURRENT]"), ("SELF-DIAG [PAST]" or "TROUBLE DIAG RECORD")

**NOTE:**

Follow the procedures in numerical order when repairing malfunctioning parts. Confirm whether malfunction is eliminated using air bag warning lamp or CONSULT-III each time repair is completed. If malfunction is still observed, proceed to the next step. When malfunction is eliminated, further repair work is not required.

Diagnostic item	Explanation	Repair order "Recheck SRS at each replacement"	
NO DTC IS DETECTED.	When malfunction is indicated by the "AIR BAG" warning lamp in User mode.	Low battery voltage (Less than 9 V)  <ul style="list-style-type: none"> <li>• Self-diagnosis result "SELF-DIAG [PAST]" (previously stored in the memory) might not be erased after repair.</li> <li>• Intermittent malfunction has been detected in the past.</li> </ul>	—  Go to <a href="#">SRC-18, "Diagnosis Description"</a> .
	No malfunction is detected.	—	
CONTROL UNIT [B1001-B1015]	Diagnosis sensor is out of order.	Replace diagnosis sensor unit (ACU).	
OCCUPANT SENS C/U [UNIT FAIL] [B1017] [B1020] [B1021]	Trouble occurs in OCS-CU.	<ol style="list-style-type: none"> <li>1. Repair or replace wiring harness / harness connector.</li> <li>2. Replace front passenger seat cushion and occupant classification system control unit as an assembly.</li> <li>3. Replace diagnosis sensor unit (ACU).</li> </ol>	
OCCUPANT SENS [UNIT FAIL] [B1018]	Trouble occurs in OCS-SENS.	<ol style="list-style-type: none"> <li>1. Repair or replace wiring harness / harness connector.</li> <li>2. Replace front passenger seat cushion and occupant classification system control unit as an assembly.</li> <li>3. Replace diagnosis sensor unit (ACU).</li> </ol>	
OCCUPANT SENS C/U [COMM FAIL] [B1022]	Trouble occurs in OCS-CU, circuit of OCS-CU-ACU, or ACU.	<ol style="list-style-type: none"> <li>1. Repair or replace wiring harness / harness connector.</li> <li>2. Replace front passenger seat cushion and occupant classification system control unit as an assembly.</li> <li>3. Replace diagnosis sensor unit (ACU).</li> </ol>	
PASS A/B INDCTR CKT [B1023]	Cut-off telltale circuit is open or shorted to ground or the circuits are shorted each other.	<ol style="list-style-type: none"> <li>1. Repair or replace wiring harness / harness connector.</li> <li>2. Replace passenger air bag off indicator.</li> <li>3. Replace diagnosis sensor unit (ACU).</li> </ol>	
CONTROL UNIT [B1026-B1031]	Diagnosis sensor is out of order.	Replace diagnosis sensor unit (ACU).	

# DIAGNOSIS SENSOR UNIT

< ECU DIAGNOSIS INFORMATION >

[FOR USA AND CANADA]

Diagnostic item	Explanation	Repair order "Recheck SRS at each replacement"	A
CRASH ZONE SEN [UNIT FAIL] [B1033] [B1034] CRASH ZONE SEN [COMM FAIL] [B1035] [UNMATCH] [B1036]  [OPEN/UPR-VB- SHORT] [B1038]  [SHORT/UPR-GND- SHORT] [B1040]	Crash zone sensor is out of order.	1. Repair or replace wiring harness / harness connector. 2. Replace crash zone sensor. 3. Replace diagnosis sensor unit (ACU).	B C D E
CONTROL UNIT [B1042-B1047]	Diagnosis sensor is out of order.	Replace diagnosis sensor unit (ACU).	F
DRIVER AIRBAG MOD- ULE [OPEN] [B1049] [B1054]	Driver air bag module circuit is open. (including the spiral cable.)	1. Repair or replace wiring harness/ harness connector. 2. Replace driver air bag module. 3. Replace spiral cable. Refer to <a href="#">SRC-45. "Diagnosis Procedure"</a> .	G
DRIVER AIRBAG MOD- ULE [VB-SHORT] [B1050] [B1055]	Driver air bag module circuit is shorted to some power supply circuit. (including the spiral cable.)	4. Replace diagnosis sensor unit (ACU).	I
DRIVER AIRBAG MOD- ULE [GND-SHORT] [B1051] [B1056]	Driver air bag module circuit is shorted to ground. (including the spiral cable.)		J
DRIVER AIRBAG MOD- ULE [SHORT] [B1052] [B1057]	<ul style="list-style-type: none"> <li>• Driver air bag module circuits are shorted to each other. (including spiral cable.)</li> <li>• Driver air bag module circuit is shorted to itself.</li> </ul>		K
CONTROL UNIT [B1058-B1063]	Diagnosis sensor is out of order.	Replace diagnosis sensor unit (ACU).	L
ASSIST A/B MODULE [OPEN] [B1065] [B1070]	Front passenger air bag module circuit is open.	1. Repair or replace wiring harness/ harness connector.	M
ASSIST A/B MODULE [VB-SHORT] [B1066] [B1071]	Front passenger air bag module circuit is shorted to some power supply circuit.	2. Replace front passenger air bag module. 3. Replace diagnosis sensor unit (ACU).	N
ASSIST A/B MODULE [GND-SHORT] [B1067] [B1072]	Front passenger air bag module circuit is shorted to ground.		O
ASSIST A/B MODULE [SHORT] [B1068] [B1073]	<ul style="list-style-type: none"> <li>• Front passenger air bag module circuits are shorted to each other.</li> <li>• Front passenger air bag module circuit is shorted to itself.</li> </ul>		P
CONTROL UNIT [B1074-B1079]	Diagnosis sensor is out of order.	Replace diagnosis sensor unit (ACU).	

SRC

## DIAGNOSIS SENSOR UNIT

< ECU DIAGNOSIS INFORMATION >

[FOR USA AND CANADA]

Diagnostic item	Explanation	Repair order "Recheck SRS at each replacement"
PRE-TEN FRONT RH [OPEN] [B1081]	Front RH seat belt pre-tensioner circuit is open.	<ol style="list-style-type: none"> <li>1. Repair or replace wiring harness/harness connector.</li> <li>2. Replace front RH seat belt pre-tensioner.</li> <li>3. Replace diagnosis sensor unit (ACU).</li> </ol>
PRE-TEN FRONT RH [VB-SHORT] [B1082]	Front RH seat belt pre-tensioner circuit is shorted to some power supply circuit.	
PRE-TEN FRONT RH [GND-SHORT] [B1083]	Front RH seat belt pre-tensioner circuit is shorted to ground.	
PRE-TEN FRONT RH [SHORT] [B1084]	<ul style="list-style-type: none"> <li>• Front RH seat belt pre-tensioner circuits are shorted to each other.</li> <li>• Front RH seat belt pre-tensioner circuit is shorted to itself.</li> </ul>	
PRE-TEN FRONT LH [OPEN] [B1086]	Front LH seat belt pre-tensioner circuit is open.	<ol style="list-style-type: none"> <li>1. Repair or replace wiring harness/harness connector.</li> <li>2. Replace front LH seat belt pre-tensioner.</li> <li>3. Replace diagnosis sensor unit (ACU).</li> </ol>
PRE-TEN FRONT LH [VB-SHORT] [B1087]	Front LH seat belt pre-tensioner circuit is shorted to some power supply circuit.	
PRE-TEN FRONT LH [GND-SHORT] [B1088]	Front LH seat belt pre-tensioner circuit is shorted to ground.	
PRE-TEN FRONT LH [SHORT] [B1089]	<ul style="list-style-type: none"> <li>• Front LH seat belt pre-tensioner circuits are shorted to each other.</li> <li>• Front LH seat belt pre-tensioner circuit is shorted to itself.</li> </ul>	
CONTROL UNIT [B1106-B1111]	Diagnosis sensor is out of order.	Replace diagnosis sensor unit (ACU).
SATELLITE SENS RH [UNIT FAIL] [B1113] [B1114] SATELLITE SENS RH [COMM FAIL] [B1115] [UNMATCH] [B1116]	RH satellite sensor is out of order.	<ol style="list-style-type: none"> <li>1. Repair or replace wiring harness/harness connector.</li> <li>2. Replace RH satellite sensor.</li> <li>3. Replace diagnosis sensor unit (ACU).</li> </ol>
SATELLITE SENS LH [UNIT FAIL] [B1118] [B1119] SATELLITE SENS LH [COMM FAIL] [B1120] [UNMATCH] [B1121]	LH satellite sensor is out of order.	<ol style="list-style-type: none"> <li>1. Repair or replace wiring harness/harness connector.</li> <li>2. Replace LH satellite sensor.</li> <li>3. Replace diagnosis sensor unit (ACU).</li> </ol>
CONTROL UNIT [B1122-B1127]	Diagnosis sensor is out of order.	Replace diagnosis sensor unit (ACU).

# DIAGNOSIS SENSOR UNIT

< ECU DIAGNOSIS INFORMATION >

[FOR USA AND CANADA]

Diagnostic item	Explanation	Repair order "Recheck SRS at each replacement"	
SIDE MODULE RH [OPEN] [B1129]	Front RH side air bag module circuit is open.	<ol style="list-style-type: none"> <li>1. Repair or replace wiring harness/harness connector.</li> <li>2. Replace front RH side air bag module.</li> <li>3. Replace diagnosis sensor unit (ACU).</li> </ol>	A
SIDE MODULE RH [VB-SHORT] [B1130]	Front RH side air bag module circuit is shorted to some power supply circuit.		B
SIDE MODULE RH [GND-SHORT] [B1131]	Front RH side air bag module circuit is shorted to ground.		C
SIDE MODULE RH [SHORT] [B1132]	<ul style="list-style-type: none"> <li>• Front LH seat belt pre-tensioner circuits are shorted to each other.</li> <li>• Front LH seat belt pre-tensioner circuit is shorted to itself.</li> </ul>		D
SIDE MODULE LH [OPEN] [B1134]	Front LH side air bag module circuit is open.	<ol style="list-style-type: none"> <li>1. Repair or replace wiring harness/harness connector.</li> <li>2. Replace front LH side air bag module.</li> <li>3. Replace diagnosis sensor unit (ACU).</li> </ol>	E
SIDE MODULE LH [VB-SHORT] [B1135]	Front LH side air bag module circuit is shorted to some power supply circuit.		F
SIDE MODULE LH [GND-SHORT] [B1136]	Front LH side air bag module circuit is shorted to ground.		G
SIDE MODULE LH [SHORT] [B1137]	<ul style="list-style-type: none"> <li>• Front LH side air bag module circuits are shorted to each other.</li> <li>• Front LH side air bag module circuit is shorted to itself.</li> </ul>		H
CONTROL UNIT [B1138-B1143]	Diagnosis sensor is out of order.	Replace diagnosis sensor unit (ACU).	I
CURTAIN MODULE RH [OPEN] [B1145]	RH side curtain air bag module circuit is open.	<ol style="list-style-type: none"> <li>1. Repair or replace wiring harness/harness connector.</li> <li>2. Replace RH side curtain air bag module.</li> <li>3. Replace diagnosis sensor unit (ACU).</li> </ol>	J
CURTAIN MODULE RH [VB-SHORT] [B1146]	RH side curtain air bag module circuit is shorted to some power supply circuit.		K
CURTAIN MODULE RH [GND-SHORT] [B1147]	RH side curtain air bag module circuit is shorted to ground.		L
CURTAIN MODULE RH [SHORT] [B1148]	<ul style="list-style-type: none"> <li>• RH side curtain air bag module circuits are shorted to each other.</li> <li>• RH side curtain air bag module circuit is shorted to itself.</li> </ul>		M
CURTAIN MODULE LH [OPEN] [B1150]	LH side curtain air bag module circuit is open.	<ol style="list-style-type: none"> <li>1. Repair or replace wiring harness/harness connector.</li> <li>2. Replace LH side curtain air bag module.</li> <li>3. Replace diagnosis sensor unit (ACU).</li> </ol>	N
CURTAIN MODULE LH [VB-SHORT] [B1151]	LH side curtain air bag module circuit is shorted to some power supply circuits.		O
CURTAIN MODULE LH [GND-SHORT] [B1152]	LH side curtain air bag module circuit is shorted to ground.		P
CURTAIN MODULE LH [SHORT] [B1153]	<ul style="list-style-type: none"> <li>• LH side curtain air bag module circuits are shorted to each other.</li> <li>• LH side curtain air bag module circuit is shorted to itself.</li> </ul>		
CONTROL UNIT [B1170-B1175]	Diagnosis sensor is out of order.	Replace diagnosis sensor unit (ACU).	

SRC

# DIAGNOSIS SENSOR UNIT

< ECU DIAGNOSIS INFORMATION >

[FOR USA AND CANADA]

Diagnostic item	Explanation	Repair order "Recheck SRS at each replacement"
PRE-TEN2 FRONT RH [OPEN] [B1177]	Front RH seat belt pre-tensioner 2 circuit is open.	<ol style="list-style-type: none"> <li>1. Repair or replace wiring harness/harness connector.</li> <li>2. Replace front RH seat belt pre-tensioner 2.</li> <li>3. Replace diagnosis sensor unit (ACU).</li> </ol>
PRE-TEN2 FRONT RH [VB-SHORT] [B1178]	Front RH seat belt pre-tensioner 2 circuit is shorted to some power supply circuit.	
PRE-TEN2 FRONT RH [GND-SHORT] [B1179]	Front RH seat belt pre-tensioner 2 circuit is shorted to ground.	
PRE-TEN2 FRONT RH [SHORT] [B1180]	<ul style="list-style-type: none"> <li>• Front RH seat belt pre-tensioner 2 circuits are shorted to each other.</li> <li>• Front RH seat belt pre-tensioner 2 circuit is shorted to itself.</li> </ul>	
PRE-TEN2 FRONT LH [OPEN] [B1182]	Front LH seat belt pre-tensioner 2 circuit is open.	<ol style="list-style-type: none"> <li>1. Repair or replace wiring harness/harness connector.</li> <li>2. Replace front LH seat belt pre-tensioner 2.</li> <li>3. Replace diagnosis sensor unit (ACU).</li> </ol>
PRE-TEN2 FRONT LH [VB-SHORT] [B1183]	Front LH seat belt pre-tensioner 2 circuit is shorted to some power supply circuit.	
PRE-TEN2 FRONT LH [GND-SHORT] [B1184]	Front LH seat belt pre-tensioner 2 circuit is shorted to ground.	
PRE-TEN2 FRONT LH [SHORT] [B1185]	<ul style="list-style-type: none"> <li>• Front LH seat belt pre-tensioner 2 circuits are shorted to each other.</li> <li>• Front LH seat belt pre-tensioner 2 circuit is shorted to itself.</li> </ul>	
CONTROL UNIT [B1202-B1207]	Diagnosis sensor is out of order.	Replace diagnosis sensor unit (ACU).
FRONTAL COLLISION DETECTION [B1209]	Seat belt pre-tensioner and front air bag is deployed.	Go to <a href="#">SRC-150, "Diagnosis Procedure"</a> .
SIDE COLLISION DE- TECTION [B1210]	Side and curtain air bag is deployed.	Go to <a href="#">SRC-152, "Diagnosis Procedure"</a> .

## WARNING LAMP FLASH CODE CHART (Without CONSULT-III)

### NOTE:

Follow the procedures in numerical order when repairing malfunctioning parts. Confirm whether malfunction is eliminated using air bag warning lamp or CONSULT-III each time repair is completed. If malfunction is still observed, proceed to the next step. When malfunction is eliminated, further repair work is not required.

<Diagnosis results (previously stored in the memory) might not be erased after repair or intermittent malfunctions have been detected in the past.>	
Flash pattern a through b are repeated. IGN ON 	Repair order <ol style="list-style-type: none"> <li>1. Erase memory. (Once key switch is turned from OFF to ON, TROUBLE DIAG RECORD will be erased.)</li> </ol>

PHIA0532E

# DIAGNOSIS SENSOR UNIT

< ECU DIAGNOSIS INFORMATION >

[FOR USA AND CANADA]

<Diagnosis sensor unit>	
Flash pattern	Repair order
<p>a through d are repeated. d: Seven flashes indicate malfunctioning diagnosis sensor unit circuit.</p>	<ol style="list-style-type: none"> <li>1. Replace the diagnosis sensor unit (ACU).</li> </ol>

JMHIA0034GB

<Occupant classification system>	
Flash pattern	Repair order
<p>a through d are repeated. d: Five flashes indicate malfunctioning OCS control unit.</p>	<ol style="list-style-type: none"> <li>1. Visually check the wiring harness connection.</li> <li>2. Replace the harness if it has visible damage.</li> <li>3. Replace front passenger seat cushion and occupant classification system control unit as an assembly.</li> <li>4. Replace the diagnosis sensor unit (ACU).</li> </ol>

JMHIA0045GB

<Front passenger air bag off indicator>	
Flash pattern	Repair order
<p>a through d are repeated. d: Eleven flashes indicate malfunctioning front passenger air bag off indicator.</p>	<ol style="list-style-type: none"> <li>1. Visually check the wiring harness connection.</li> <li>2. Replace the harness if it has visible damage.</li> <li>3. Replace front passenger air bag off indicator unit.</li> <li>4. Replace the diagnosis sensor unit (ACU).</li> </ol>

JMHIA0046GB

<Crash zone sensor>	
Flash pattern	Repair order
<p>a through d are repeated. d: Six flashes indicate malfunctioning crash zone sensor circuit.</p>	<ol style="list-style-type: none"> <li>1. Visually check the wiring harness connection.</li> <li>2. Replace the harness if it has visible damage.</li> <li>3. Replace the crash zone sensor.</li> <li>4. Replace the diagnosis sensor unit.</li> </ol>

JMHIA0036GB

<Driver air bag module>	
Flash pattern	Repair order
<p>a through d are repeated. d: Two flashes indicate malfunctioning driver air bag module circuit.</p>	<ol style="list-style-type: none"> <li>1. Visually check the wiring harness connection.</li> <li>2. Replace the harness if it has visible damage.</li> <li>3. Replace the driver air bag module.</li> <li>4. Replace the spiral cable.</li> <li>5. Replace the diagnosis sensor unit (ACU).</li> </ol>

JMHIA0033GB

A

B

C

D

E

F

G

SRC

I

J

K

L

M

N

O

P

# DIAGNOSIS SENSOR UNIT

< ECU DIAGNOSIS INFORMATION >

[FOR USA AND CANADA]

<Front passenger air bag module>	
Flash pattern	Repair order
<p>a through d are repeated. d: Eight flashes indicate malfunctioning front passenger air bag module circuit.</p>	<ol style="list-style-type: none"> <li>1. Visually check the wiring harness connection.</li> <li>2. Replace the harness if it has visible damage.</li> <li>3. Replace the front passenger air bag module.</li> <li>4. Replace the diagnosis sensor unit (ACU).</li> </ol>

JMHIA0035GB

<Front RH seat belt pre-tensioner>	
Flash pattern	Repair order
<p>a through d are repeated. d: One flash indicates malfunctioning front RH seat belt pre-tensioner circuit.</p>	<ol style="list-style-type: none"> <li>1. Visually check the wiring harness connections.</li> <li>2. Replace the harness if it has visible damage.</li> <li>3. Replace the front RH seat belt.</li> <li>4. Replace the diagnosis sensor unit (ACU).</li> </ol>

JMHIA0037GB

<Front LH seat belt pre-tensioner>	
Flash pattern	Repair order
<p>a through d are repeated. d: Three flashes indicate malfunctioning front LH seat belt pre-tensioner circuit.</p>	<ol style="list-style-type: none"> <li>1. Visually check the wiring harness connections.</li> <li>2. Replace the harness if it has visible damage.</li> <li>3. Replace the front LH seat belt.</li> <li>4. Replace the diagnosis sensor unit (ACU).</li> </ol>

JMHIA0038GB

<RH side air bag (Satellite) sensor>	
Flash pattern	Repair order
<p>a through f are repeated. f: Three flashes indicate malfunctioning RH side air bag (Satellite) sensor circuit.</p>	<ol style="list-style-type: none"> <li>1. Visually check the wiring harness connection.</li> <li>2. Replace the harness if it has visible damage.</li> <li>3. Replace the RH side air bag (Satellite) sensor.</li> <li>4. Replace the diagnosis sensor unit.</li> </ol>

JMHIA0039GB

<LH side air bag (Satellite) sensor>	
Flash pattern	Repair order
<p>a through f are repeated. f: Four flashes indicate malfunctioning LH side air bag (Satellite) sensor.</p>	<ol style="list-style-type: none"> <li>1. Visually check the wiring harness connection.</li> <li>2. Replace the harness if it has visible damage.</li> <li>3. Replace the LH side air bag (Satellite) sensor.</li> <li>4. Replace the diagnosis sensor unit.</li> </ol>

JMHIA0040GB



# DIAGNOSIS SENSOR UNIT

< ECU DIAGNOSIS INFORMATION >

[FOR USA AND CANADA]

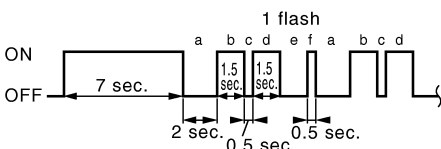
<Front RH side air bag module>	
Flash pattern	Repair order
<p>a through f are repeated. f: One flash indicates malfunctioning front RH side air bag module circuit.</p> 	<ol style="list-style-type: none"> <li>1. Visually check the wiring harness connection.</li> <li>2. Replace the harness if it has visible damage.</li> <li>3. Replace the front RH side air bag module.</li> <li>4. Replace the diagnosis sensor unit (ACU).</li> </ol>
JMHIA0041GB	

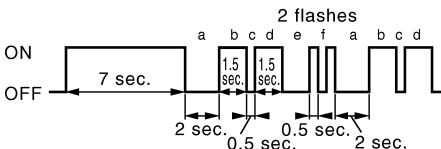
<Front LH side air bag module>	
Flash pattern	Repair order
<p>a through f are repeated. f: Two flashes indicate malfunctioning front LH side air bag module circuit.</p> 	<ol style="list-style-type: none"> <li>1. Visually check the wiring harness connection.</li> <li>2. Replace the harness if it has visible damage.</li> <li>3. Replace the front LH side air bag module.</li> <li>4. Replace the diagnosis sensor unit (ACU).</li> </ol>
JMHIA0042GB	

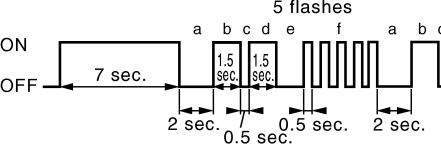
<RH side curtain air bag module>	
Flash pattern	Repair order
<p>a through f are repeated. f: Five flashes indicate malfunctioning RH side curtain air bag module circuit.</p> 	<ol style="list-style-type: none"> <li>1. Visually check the wiring harness connection.</li> <li>2. Replace the harness if it has visible damage.</li> <li>3. Replace the RH side curtain air bag module.</li> <li>4. Replace the diagnosis sensor unit (ACU).</li> </ol>
JMHIA0043GB	

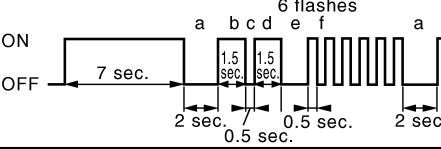
<LH side curtain air bag module>	
Flash pattern	Repair order
<p>a through f are repeated. f: Six flashes indicate malfunctioning LH side curtain air bag module circuit.</p> 	<ol style="list-style-type: none"> <li>1. Visually check the wiring harness connection.</li> <li>2. Replace the harness if it has visible damage.</li> <li>3. Replace the LH side curtain air bag module.</li> <li>4. Replace the diagnosis sensor unit (ACU).</li> </ol>
JMHIA0044GB	

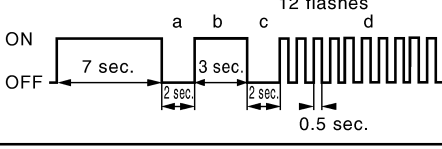
<Front RH seat belt pre-tensioner 2>	
Flash pattern	Repair order
<p>a through d are repeated. d: Twelve flashes indicates malfunctioning front RH seat belt pre-tensioner 2 circuit.</p> 	<ol style="list-style-type: none"> <li>1. Visually check the wiring harness connections.</li> <li>2. Replace the harness if it has visible damage.</li> <li>3. Replace the front RH seat belt pre-tensioner 2.</li> <li>4. Replace the diagnosis sensor unit (ACU).</li> </ol>
JMHIA0223GB	

A  
B  
C  
D  
E  
F  
G  
I  
J  
K  
L  
M  
N  
O  
P

SRC

# DIAGNOSIS SENSOR UNIT

< ECU DIAGNOSIS INFORMATION >

[FOR USA AND CANADA]

<Front LH seat belt pre-tensioner 2>	
Flash pattern	Repair order
<p>a through d are repeated.                      d: Thirteen flashes indicate malfunctioning front LH seat belt pre-tensioner 2 circuit.</p>	<ol style="list-style-type: none"> <li>1. Visually check the wiring harness connections.</li> <li>2. Replace the harness if it has visible damage.</li> <li>3. Replace the front LH seat belt pre-tensioner 2.</li> <li>4. Replace the diagnosis sensor unit (ACU).</li> </ol>

JMHIA0222GB

# DIAGNOSIS SENSOR UNIT

< ECU DIAGNOSIS INFORMATION >

[FOR USA AND CANADA]

## Wiring Diagram — SRS AIR BAG CONTROL SYSTEM —

INFOID:000000005252833

### SRS AIR BAG CONTROL SYSTEM (WITH ADVANCED AIR BAG)

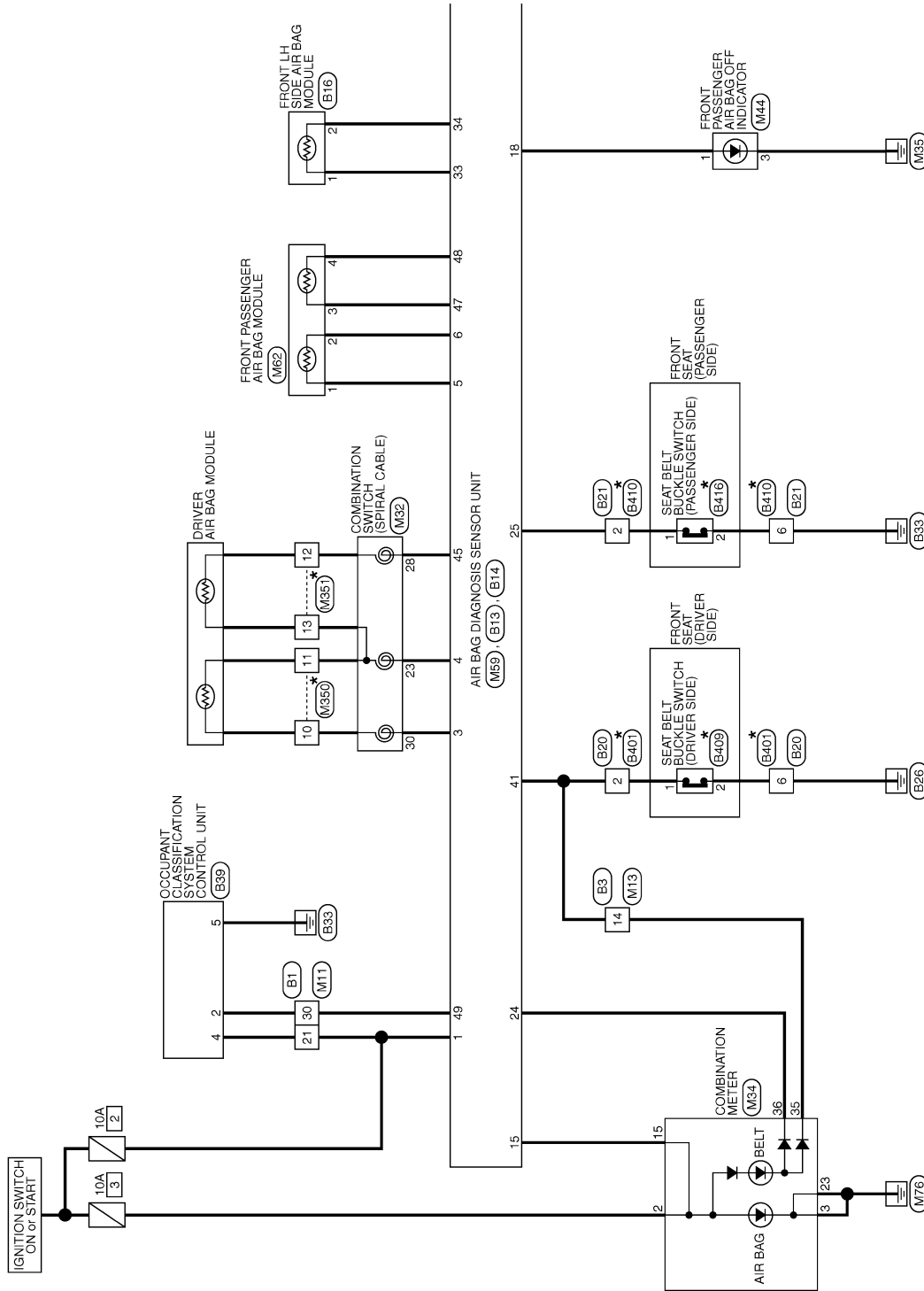

\*: This connector is not shown in "Harness Layout".

2009/07/10

JCHWA0370GE

A  
B  
C  
D  
E  
F  
G  
SRC  
I  
J  
K  
L  
M  
N  
O  
P

# DIAGNOSIS SENSOR UNIT

< ECU DIAGNOSIS INFORMATION >

[FOR USA AND CANADA]

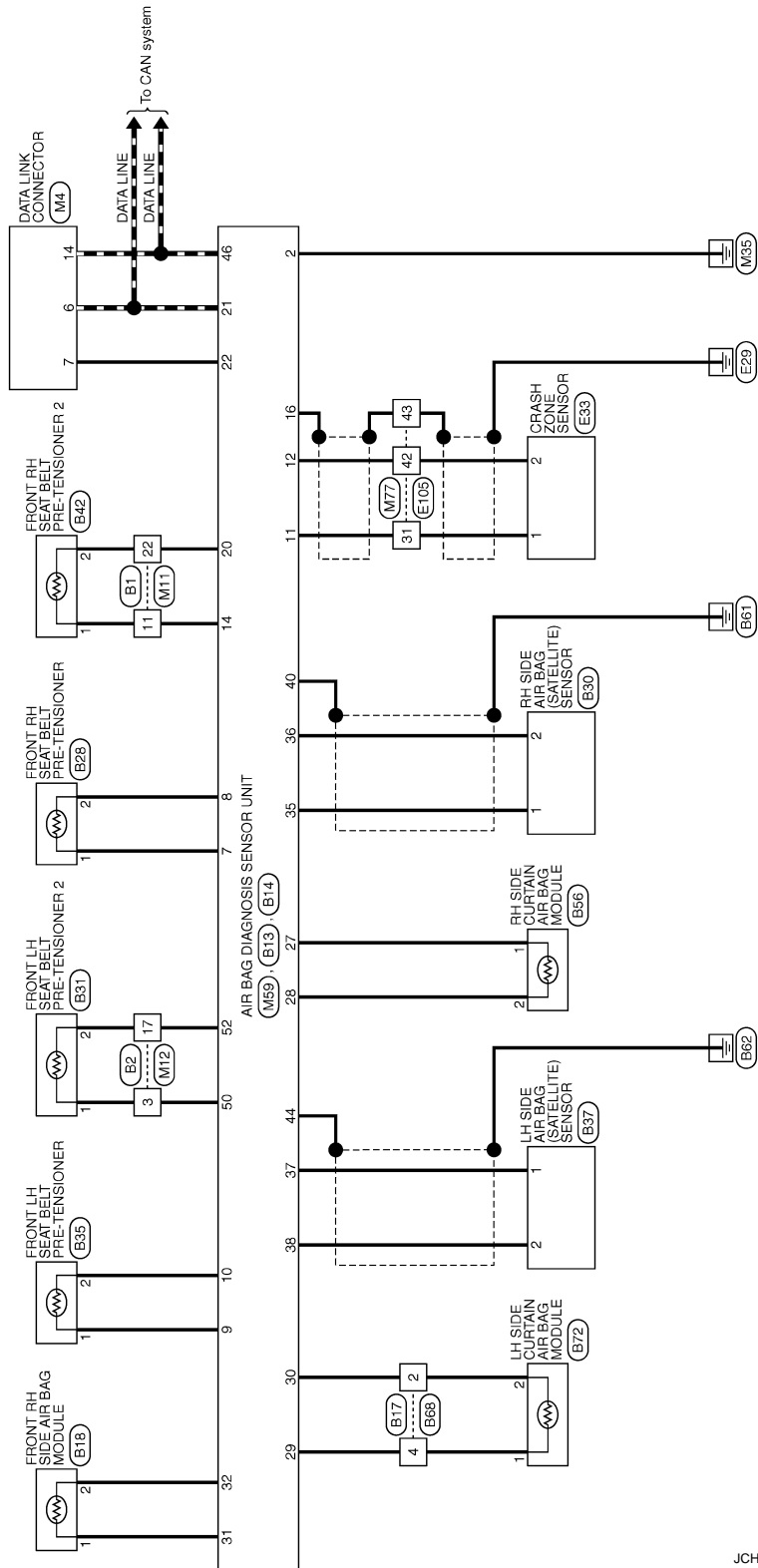

JCHWA0371GE

# DIAGNOSIS SENSOR UNIT

< ECU DIAGNOSIS INFORMATION >

[FOR USA AND CANADA]

## SRS AIR BAG CONTROL SYSTEM (WITH ADVANCED AIR BAG)

Connector No.	B13
Connector Name	AIR BAG DIAGNOSIS SENSOR UNIT
Connector Type	TK12FY-1V-EX



Terminal No.	Color of Wire	Signal Name [Specification]
7	O	ELR RH+
8	V	ELR RH-
25	LG	BUCKLE SW RH
27	R	INF CURTAIN RR RH+
28	W	INF CURTAIN RR RH-
31	W	SIDE INF RH+
32	L	SIDE INF RH-
35	BR	SIDE SENS RH+
36	Y	SIDE SENS RH-
40	SHIELD	GND]For North America]

Connector No.	B3
Connector Name	WIRE TO WIRE
Connector Type	TH22MW-NH



Terminal No.	Color of Wire	Signal Name [Specification]
14	BR	-

Connector No.	B2
Connector Name	WIRE TO WIRE
Connector Type	TH22MW-NH



Terminal No.	Color of Wire	Signal Name [Specification]
3	P	-
17	O	-

Connector No.	B1
Connector Name	WIRE TO WIRE
Connector Type	TH20MW-CS1F-TM4



Terminal No.	Color of Wire	Signal Name [Specification]
11	P	-
21	R	-
22	GR	-
30	V	-

Connector No.	B18
Connector Name	FRONT RH SIDE AIR BAG MODULE
Connector Type	TK02FY-EX-1V



Terminal No.	Color of Wire	Signal Name [Specification]
1	W	-
2	L	-

Connector No.	B17
Connector Name	WIRE TO WIRE
Connector Type	TK04MY-BD



Terminal No.	Color of Wire	Signal Name [Specification]
2	V	-
4	LG	-

Connector No.	B16
Connector Name	FRONT LH SIDE AIR BAG MODULE
Connector Type	TK02FY-EX-1V



Terminal No.	Color of Wire	Signal Name [Specification]
1	W	-
2	L	-

Connector No.	B14
Connector Name	AIR BAG DIAGNOSIS SENSOR UNIT
Connector Type	TK12FY-2V-EX



Terminal No.	Color of Wire	Signal Name [Specification]
9	Y	ELR LH+
10	SB	ELR LH-
28	LG	INF CURTAIN RR LH+
30	V	INF CURTAIN RR LH-
33	W	SIDE INF LH+
34	L	SIDE INF LH-
37	G	SIDE SENS LH+
38	R	SIDE SENS LH-
41	BR	BUCKLE SW LH
44	SHIELD	GND]For North America]

A  
B  
C  
D  
E  
F  
G  
H  
I  
J  
K  
L  
M  
N  
O  
P

SRC











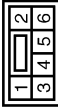







JCHWA0372GE

# DIAGNOSIS SENSOR UNIT

< ECU DIAGNOSIS INFORMATION >

[FOR USA AND CANADA]

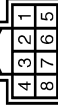
## SRS AIR BAG CONTROL SYSTEM (WITH ADVANCED AIR BAG)

Connector No. B20	WIRE TO WIRE	NS06FY-CS			Terminal No. 1	Color of Wire P	Signal Name [Specification]	
Connector Name	WIRE TO WIRE	NS06FY-CS			2	BR		
Connector Type					6	B		
Connector No. B21	WIRE TO WIRE	NS06FY-CS			Terminal No. 1	LG	Signal Name [Specification]	
Connector Name	WIRE TO WIRE	NS06FY-CS			2	LG		
Connector Type					6	B		
Connector No. B28	FRONT RH SEAT BELT PRE-TENSIONER	ACA02FY-2V			Terminal No. 1	O	Signal Name [Specification]	
Connector Name	FRONT RH SEAT BELT PRE-TENSIONER	ACA02FY-2V			2	V		
Connector Type								
Connector No. B29	RIGHT SIDE AIR BAG (SATELLITE) SENSOR	HK02FY-1V-EX			Terminal No. 1	BR	Signal Name [Specification]	
Connector Name	RIGHT SIDE AIR BAG (SATELLITE) SENSOR	HK02FY-1V-EX			2	Y		
Connector Type								
Connector No. B30	RIGHT SIDE AIR BAG (SATELLITE) SENSOR	HK02FY-1V-EX			Terminal No. 1	BR	Signal Name [Specification]	
Connector Name	RIGHT SIDE AIR BAG (SATELLITE) SENSOR	HK02FY-1V-EX			2	Y		
Connector Type								
Connector No. B31	FRONT LH SEAT BELT PRE-TENSIONER	ACA02FOR			Terminal No. 1	P	Signal Name [Specification]	
Connector Name	FRONT LH SEAT BELT PRE-TENSIONER	ACA02FOR			2	O		
Connector Type								
Connector No. B35	FRONT LH SEAT BELT PRE-TENSIONER	ACA02FY-2V			Terminal No. 1	Y	Signal Name [Specification]	
Connector Name	FRONT LH SEAT BELT PRE-TENSIONER	ACA02FY-2V			2	SB		
Connector Type								
Connector No. B37	LH SIDE AIR BAG (SATELLITE) SENSOR	HK02FY-1V-EX			Terminal No. 1	G	Signal Name [Specification]	
Connector Name	LH SIDE AIR BAG (SATELLITE) SENSOR	HK02FY-1V-EX			2	R		
Connector Type								
Connector No. B39	OCCUPANT CLASSIFICATION SYSTEM CONTROL UNIT	TR08FW-NH			Terminal No. 1	V	Signal Name [Specification]	
Connector Name	OCCUPANT CLASSIFICATION SYSTEM CONTROL UNIT	TR08FW-NH			2	R	COMMUNICATION	
Connector Type					4	R	IGN	
					5	B	GND	

JCHWM0316G1

# DIAGNOSIS SENSOR UNIT

< ECU DIAGNOSIS INFORMATION >

[FOR USA AND CANADA]

## SRS AIR BAG CONTROL SYSTEM (WITH ADVANCED AIR BAG)

Connector No.	B42
Connector Name	FRONT RH SEAT BELT PRE-TENSIONER
Connector Type	ACA02FOR



Terminal No.	Color of Wire	Signal Name [Specification]
1	P	-
2	GR	-

Connector No.	B56
Connector Name	RH SIDE CURTAIN AIR BAG MODULE
Connector Type	ACA02FY-2V



Terminal No.	Color of Wire	Signal Name [Specification]
1	R	-
2	W	-

Connector No.	B68
Connector Name	WIRE TO WIRE
Connector Type	TK04FY



Terminal No.	Color of Wire	Signal Name [Specification]
2	V	-
4	LG	-

Connector No.	B72
Connector Name	LH SIDE CURTAIN AIR BAG MODULE
Connector Type	ACA02FY-2V



Terminal No.	Color of Wire	Signal Name [Specification]
1	LG	-
2	V	-

Connector No.	B401
Connector Name	WIRE TO WIRE
Connector Type	NS08MW-CS



Terminal No.	Color of Wire	Signal Name [Specification]
2	W/G	-
6	GR	-

Connector No.	B409
Connector Name	SEAT BELT BUCKLE SWITCH (DRIVER SIDE)
Connector Type	TK03FW



Terminal No.	Color of Wire	Signal Name [Specification]
1	W/G	-
2	GR	-

Connector No.	B410
Connector Name	WIRE TO WIRE
Connector Type	NS08MW-CS



Terminal No.	Color of Wire	Signal Name [Specification]
2	W/G	-
6	GR	-

Connector No.	B418
Connector Name	SEAT BELT BUCKLE SWITCH (PASSENGER SIDE)
Connector Type	TK03FW



Terminal No.	Color of Wire	Signal Name [Specification]
1	W/G	-
2	GR	-

A  
B  
C  
D  
E  
F  
G  
SRC  
I  
J  
K  
L  
M  
N  
O  
P

JCHWA0373GE

# DIAGNOSIS SENSOR UNIT

< ECU DIAGNOSIS INFORMATION >

[FOR USA AND CANADA]

## SRS AIR BAG CONTROL SYSTEM (WITH ADVANCED AIR BAG)

Connector No.	E33
Connector Name	CRASH ZONE SENSOR
Connector Type	HK2FY-1V-EX



Terminal No.	Color of Wire	Signal Name [Specification]
1	BR	-
2	Y	-

Connector No.	E105
Connector Name	WIRE TO WIRE
Connector Type	TH80FW-CS16-TM4



Terminal No.	Color of Wire	Signal Name [Specification]
31	BR	-
42	Y	-
43	SHIELD	-

Connector No.	M4
Connector Name	DATA LINK CONNECTOR
Connector Type	BD16FW

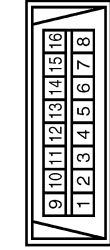

Terminal No.	Color of Wire	Signal Name [Specification]
6	L	-
7	O	-
14	P	-

Connector No.	M11
Connector Name	WIRE TO WIRE
Connector Type	TH80FW-CS16-TM4



Terminal No.	Color of Wire	Signal Name [Specification]
11	BR	-
21	R	-
22	GR	-
30	V	-

Connector No.	M12
Connector Name	WIRE TO WIRE
Connector Type	TH24FW-NH

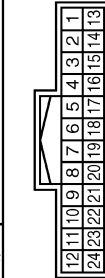

Terminal No.	Color of Wire	Signal Name [Specification]
3	P	-
17	SB	-

Connector No.	M13
Connector Name	WIRE TO WIRE
Connector Type	TH32FW-NH

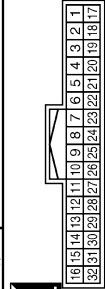

Terminal No.	Color of Wire	Signal Name [Specification]
14	O	-

Connector No.	M32
Connector Name	COMBINATION SWITCH (SPIRAL CABLE)
Connector Type	TK08FY-EX-1V



Terminal No.	Color of Wire	Signal Name [Specification]
23	Y/R	-
28	Y/G	-
30	Y	-

Connector No.	M34
Connector Name	COMBINATION METER
Connector Type	SAB0FW

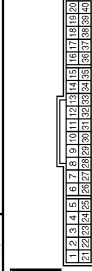

Terminal No.	Color of Wire	Signal Name [Specification]
2	O	IGN
3	B	GND2(POWER)
15	LG	AIR BAG
23	B	GND3(CIRCUIT)
35	O	SEAT BELT BUCKLE SW (DRIVER SIDE)
36	G	SEAT BELT BUCKLE SW (PASSENGER SIDE)



# DIAGNOSIS SENSOR UNIT

< ECU DIAGNOSIS INFORMATION >

[FOR USA AND CANADA]

## SRS AIR BAG CONTROL SYSTEM (WITH ADVANCED AIR BAG)

Connector No.	M44
Connector Name	FRONT PASSENGER AIR BAG OFF INDICATOR
Connector Type	TK33FW



Terminal No.	Color of Wire	Signal Name [Specification]
1	GR	-
3	B	-

Connector No.	M59
Connector Name	AIR BAG DIAGNOSIS SENSOR UNIT (WITH ADVANCED AIR BAG)
Connector Type	TK23FY-EX-SC

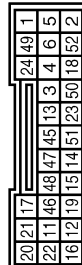

Terminal No.	Color of Wire	Signal Name [Specification]
1	R	IGN
2	B	GND
3	Y	INFLATOR DRI+
4	Y/R	INFLATOR DRI-SDR2-
5	Y/G	INFLATOR AST+
6	Y/B	INFLATOR AST-
11	W	ECZS+
12	O	ECZS-
14	BR	ELR2 RH+
15	LG	A/B W/L
16	SHIELD	GND

18	GR	A/B CUTOFF TELLTALE
20	GR	ELR2 RH-
21	L	CSM HI
22	Y	K-LINE
24	G	SEATBELT W/L
45	Y/G	INFLATOR DR2+
46	P	CAN LO
47	Y	INFLATOR AS2+
48	Y/R	INFLATOR AS2-
49	V	ODS INPUT
50	P	ELR2 LH+
52	SB	ELR2 LH-



Terminal No.	Color of Wire	Signal Name [Specification]
1	Y/G	-
2	Y/B	-
3	Y	-
4	Y/R	-

Connector No.	M62
Connector Name	FRONT PASSENGER AIR BAG MODULE (WITH ADVANCED AIR BAG)
Connector Type	TK33FY-BD

Connector No.	M77
Connector Name	WIRE TO WIRE
Connector Type	TH80MW-CST1F-TM4

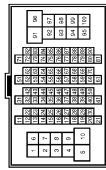

Terminal No.	Color of Wire	Signal Name [Specification]
31	W	-
42	O	-
43	SHIELD	-

Connector No.	M350
Connector Name	DRIVER AIR BAG MODULE
Connector Type	ACA02FY-2V



Terminal No.	Color of Wire	Signal Name [Specification]
10	-	-
11	-	-

Connector No.	M351
Connector Name	DRIVER AIR BAG MODULE
Connector Type	ACA02FOR



Terminal No.	Color of Wire	Signal Name [Specification]
12	-	-
13	-	-

A  
B  
C  
D  
E  
F  
G  
H  
I  
J  
K  
L  
M  
N  
O  
P

SRC

# SRS AIR BAG WARNING LAMP DOES NOT TURN OFF

< SYMPTOM DIAGNOSIS >

[FOR USA AND CANADA]

## SYMPTOM DIAGNOSIS

### SRS AIR BAG WARNING LAMP DOES NOT TURN OFF

#### Diagnosis Procedure

INFOID:000000005252834

#### 1. CHECK AIR BAG MODULE

Check the deployment of air bag module.

Is air bag module deployed?

YES >> Refer to or [SR-5. "FOR FRONTAL COLLISION : When SRS is activated in a collision"](#) or [SR-7. "FOR SIDE AND ROLLOVER COLLISION : When SRS is activated in a collision"](#).

NO >> GO TO 2.

#### 2. CHECK AIR BAG FUSE

Check the air bag fuse. Refer to [PG-90. "Fuse and Fusible Link Arrangement"](#).

Is 10A fuse [No.2, located in fuse block (J/B)] normal?

YES >> GO TO 4.

NO >> GO TO 3.

#### 3. CHECK AIR BAG FUSE AGAIN

Replace air bag fuse and turn ignition switch ON.

Did the air bag fuse blow again?

YES >> Repair or replace main harness.

NO >> **INSPECTION END**

#### 4. CHECK DIAGNOSIS SENSOR UNIT

Check the screen of CONSULT-III.

Is the inspection result normal?

YES >> GO TO 5.

NO >> Replace diagnosis sensor unit (ACU). Refer to [SR-24. "Exploded View"](#).

#### 5. CHECK HARNESS CONNECTION

Check harness connection between air bag warning lamp and diagnosis sensor unit.

Is the inspection result normal?

YES >> Check the intermittent incident. Refer to [GI-40. "Intermittent Incident"](#).

NO >> Replace wiring harness connector.

# SRS AIR BAG WARNING LAMP DOES NOT TURN ON

< SYMPTOM DIAGNOSIS >

[FOR USA AND CANADA]

## SRS AIR BAG WARNING LAMP DOES NOT TURN ON

### Diagnosis Procedure

INFOID:000000005252835

#### 1.CHECK METER FUSE

Check the meter fuse. Refer to [PG-90, "Fuse and Fusible Link Arrangement"](#).

Is 10A fuse [No.4, located in fuse block (J/B)] normal?

YES >> GO TO 3.

NO >> GO TO 2.

#### 2.CHECK METER FUSE AGAIN

Replace 10A fuse [No.4, located in fuse block (J/B)] and turn ignition switch ON.

Did the meter fuse blow again?

YES >> Repair or replace the related harness.

NO >> **INSPECTION END**

#### 3.CHECK HARNESS CONNECTION

1. Check harness connection between diagnosis sensor unit and combination meter.

2. Disconnect diagnosis sensor unit connector and turn ignition switch ON.

Did air bag warning lamp turn ON?

YES >> Replace diagnosis sensor unit (ACU). Refer to [SR-24, "Exploded View"](#).

NO >> Replace combination meter assembly. Refer to [MWI-87, "Exploded View"](#).

A  
B  
C  
D  
E  
F  
G  
I  
J  
K  
L  
M  
N  
O  
P

SRC

# PASSENGER SEAT BELT WARNING SYSTEM

< SYMPTOM DIAGNOSIS >

[FOR USA AND CANADA]

## PASSENGER SEAT BELT WARNING SYSTEM

---

### Diagnosis Procedure

INFOID:000000005252836

#### 1.CHECK THE SYSTEM 1

---

Check the seat belt warning lamp function.

Sea tbelt warning lamp turns ON in the following conditions.

- Driver seat belt is fastened.
- Occupant is on passenger seat.
- Passenger seat belt is not fasten.

#### Is the inspection result normal?

YES >> GO TO 2.

NO >> Check the followings.

- Harness between air bag diagnosis sensor unit and combination meter.
- Seat belt buckle switch (passenger side) circuit.
- Seat belt buckle switch (passenger side).

If these are OK, replace air bag diagnosis sensor unit.

#### 2.CHECK THE SYSTEM 2

---

Check the seat belt warning lamp function.

Seat belt warning lamp turns OFF in the following conditions.

- Driver seat belt is fastened.
- Occupant is on passenger seat.
- Passenger seat belt is fastened.

#### Is the inspection result normal?

YES >> System is OK.

NO >> Check the followings.

- Seat belt buckle switch (passenger side) circuit.
- Seat belt buckle switch (passenger side).

If these are OK, replace air bag diagnosis sensor unit.

PRECAUTION

PRECAUTIONS

Precaution for Supplemental Restraint System (SRS) "AIR BAG" and "SEAT BELT PRE-TENSIONER"

INFOID:000000005252837

The Supplemental Restraint System such as "AIR BAG" and "SEAT BELT PRE-TENSIONER", used along with a front seat belt, helps to reduce the risk or severity of injury to the driver and front passenger for certain types of collision. This system includes seat belt switch inputs and dual stage front air bag modules. The SRS system uses the seat belt switches to determine the front air bag deployment, and may only deploy one front air bag, depending on the severity of a collision and whether the front occupants are belted or unbelted. Information necessary to service the system safely is included in the "SRS AIR BAG" and "SEAT BELT" of this Service Manual.

**WARNING:**

- To avoid rendering the SRS inoperative, which could increase the risk of personal injury or death in the event of a collision which would result in air bag inflation, all maintenance must be performed by an authorized NISSAN/INFINITI dealer.
- Improper maintenance, including incorrect removal and installation of the SRS, can lead to personal injury caused by unintentional activation of the system. For removal of Spiral Cable and Air Bag Module, see the "SRS AIR BAG".
- Do not use electrical test equipment on any circuit related to the SRS unless instructed to in this Service Manual. SRS wiring harnesses can be identified by yellow and/or orange harnesses or harness connectors.

PRECAUTIONS WHEN USING POWER TOOLS (AIR OR ELECTRIC) AND HAMMERS

**WARNING:**

- When working near the Air Bag Diagnosis Sensor Unit or other Air Bag System sensors with the ignition ON or engine running, DO NOT use air or electric power tools or strike near the sensor(s) with a hammer. Heavy vibration could activate the sensor(s) and deploy the air bag(s), possibly causing serious injury.
- When using air or electric power tools or hammers, always switch the ignition OFF, disconnect the battery, and wait at least 3 minutes before performing any service.

Service

INFOID:000000005252838

- Do not use electrical test equipment to check SRS circuits unless instructed to in this Service Manual.
- Before servicing the SRS, turn ignition switch OFF, disconnect both battery cables and wait at least 3 minutes. For approximately 3 minutes after the cables are removed, it is still possible for the air bag and seat belt pretensioner to deploy. Therefore, do not work on any SRS connectors or wires until at least 3 minutes have elapsed.
- Diagnosis sensor unit must always be installed with their arrow marks "⇐" pointing towards the front of the vehicle for proper operation. Also check diagnosis sensor unit for cracks, deformities or rust before installation and replace as required.
- The spiral cable must be aligned in the neutral position since its rotations are limited. Do not turn steering wheel and column after removal of steering gear.
- Handle air bag module carefully. Always place driver and front passenger air bag modules with the pad side facing upward and seat mounted front side air bag module standing with the stud bolt side facing down.
- Conduct self-diagnosis to check entire SRS for proper functioning after replacing any components.
- After air bag inflates, the front instrument panel assembly should be replaced if damaged.
- Always replace instrument panel pad following front passenger air bag deployment.

Occupant Classification System Precaution

INFOID:000000005252839

- Replace occupant classification system control unit and passenger front seat cushion as an assembly. Refer to [SE-28, "Removal and Installation"](#).

A  
B  
C  
D  
E  
F  
G  
SRC  
I  
J  
K  
L  
M  
N  
O  
P

# BASIC INSPECTION

## DIAGNOSIS AND REPAIR WORK FLOW

### Work Flow

INFOID:000000005252840

### OVERALL SEQUENCE

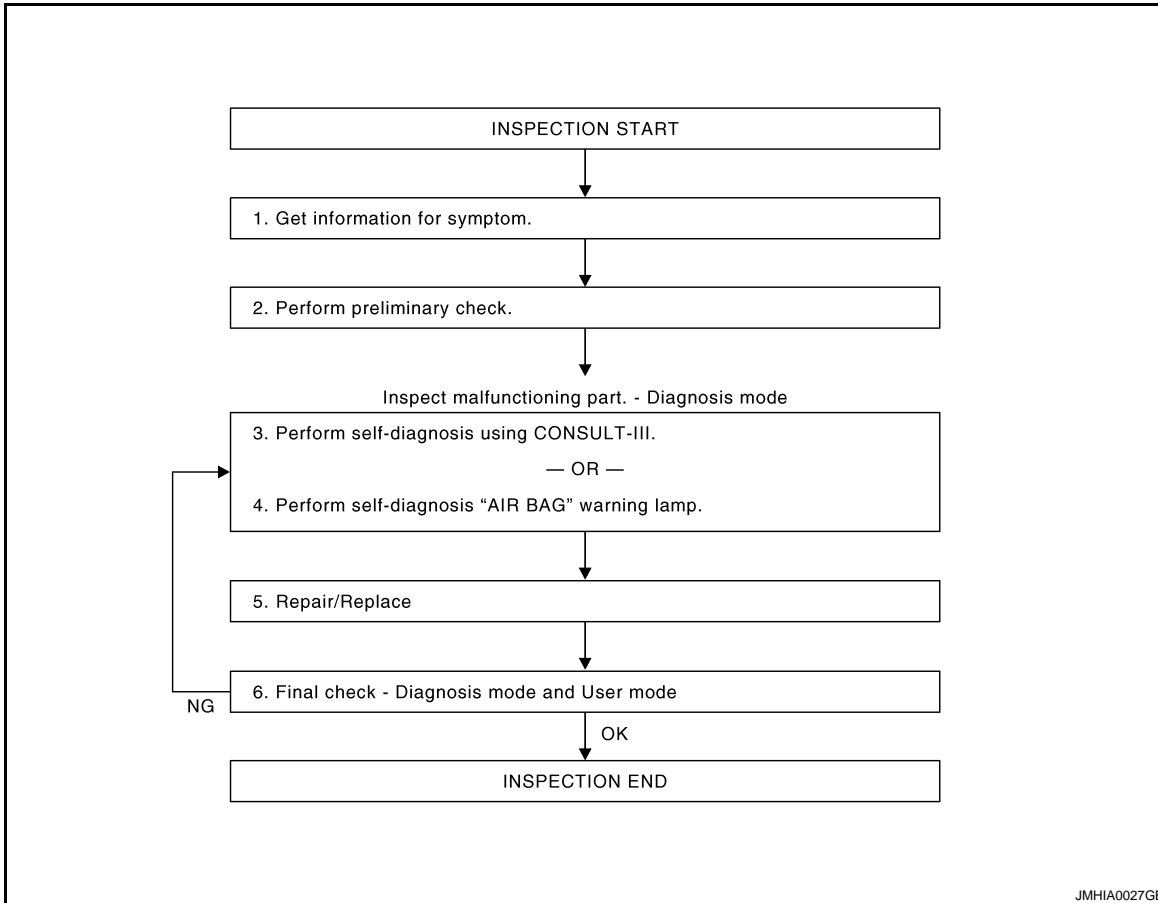

JMHA0027GB

### DETAILED FLOW

#### 1.GET INFORMATION FOR SYMPTOM

Interview the customer about the symptom.

>> GO TO 2.

#### 2.PERFORM PRELIMINARY CHECK

At the beginning of inspection, confirm the condition of power supply circuit, check that the battery is charged and fuses and fusible links are not blown.

Is power supply circuit normal?

YES-1 >> GO TO 3. (With CONSULT-III)

YES-2 >> GO TO 4. (Without CONSULT-III)

NO >> Repair or replace the battery and fuse/fusible links.

#### 3.PERFORM SELF-DIAGNOSIS USING "CONSULT-III" (WITH CONSULT-III)

Perform "AIR BAG" Self Diagnostic Result.

Is "MALFUNCTIONING PART" displayed on CONSULT-III?

YES >> GO TO 5.

NO >> Repeat DTC confirmation with diagnostic procedure.

# DIAGNOSIS AND REPAIR WORK FLOW

< BASIC INSPECTION >

[FOR MEXICO]

---

## 4.PERFORM SELF-DIAGNOSIS "AIR BAG" WARNING LAMP (WITHOUT CONSULT-III)

---

Check the air bag warning lamp status.

Is "MALFUNCTIONING PART" detected?

YES >> GO TO 5.

NO >> Repeat DTC confirmation with diagnostic procedure.

---

## 5.REPAIR OR REPLACE

---

Repair or replace the malfunctioning part.

After the malfunction is repaired, erase the self-diagnostic result. Refer to [SRC-179. "Diagnosis Description"](#) or [SRC-181. "CONSULT-III Function"](#).

>> GO TO 6.

---

## 6.FINAL CHECK

---

Perform "AIR BAG" Self Diagnostic Result with CONSULT-III and /or, air bag warning lamp status.

Are all malfunctions corrected?

YES >> **INSPECTION END**

NO-1 >> GO TO 3. (With CONSULT-III)

NO-2 >> GO TO 4. (Without CONSULT-III)

A  
B  
C  
D  
E  
F  
G  
I  
J  
K  
L  
M  
N  
O  
P

SRC

SYSTEM DESCRIPTION

SRS AIR BAG SYSTEM

System Diagram

INFOID:000000005252841

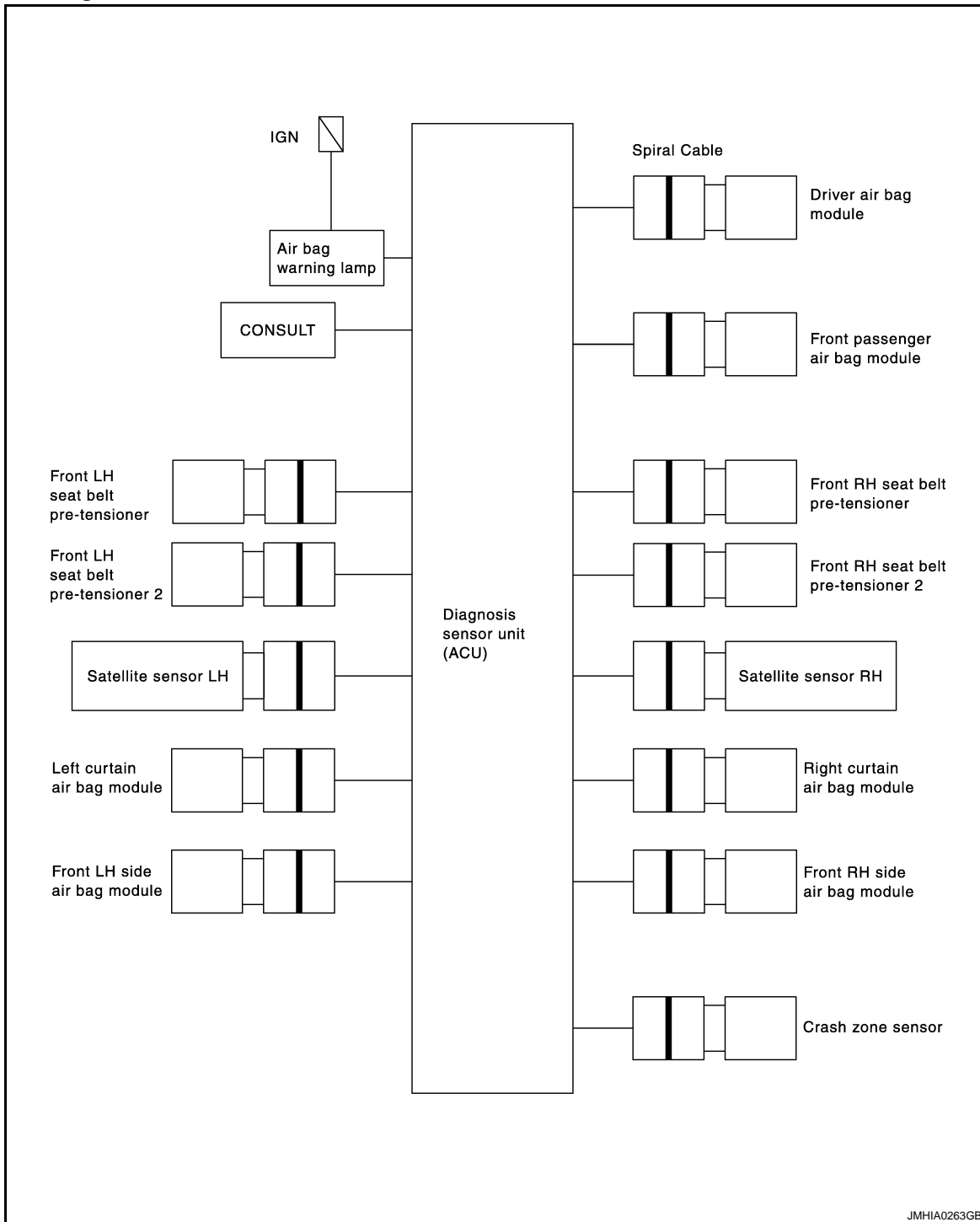

JMHIA0263GB

System Description

INFOID:000000005252842

This SRS Air Bag System has the following function.

1. Detects crash and supplies the energy for deploying air bag and seat belt pre-tensioner.
2. Detects electrical trouble in air bag system and seat belt pre-tensioner system, records trouble code, and blinking Air bag warning lamp.



# SRS AIR BAG SYSTEM

[FOR MEXICO]

## < SYSTEM DESCRIPTION >

3. Detects and records the deployment of air bag and seat belt pre-tensioner, and turns on air bag warning lamp.
4. Indicates malfunctioning portion with blinking times of air bag warning lamp in diagnosis mode.
5. Indicate the malfunctioning record by CONSULT-III.

## Component Parts Location

INFOID:000000005252843

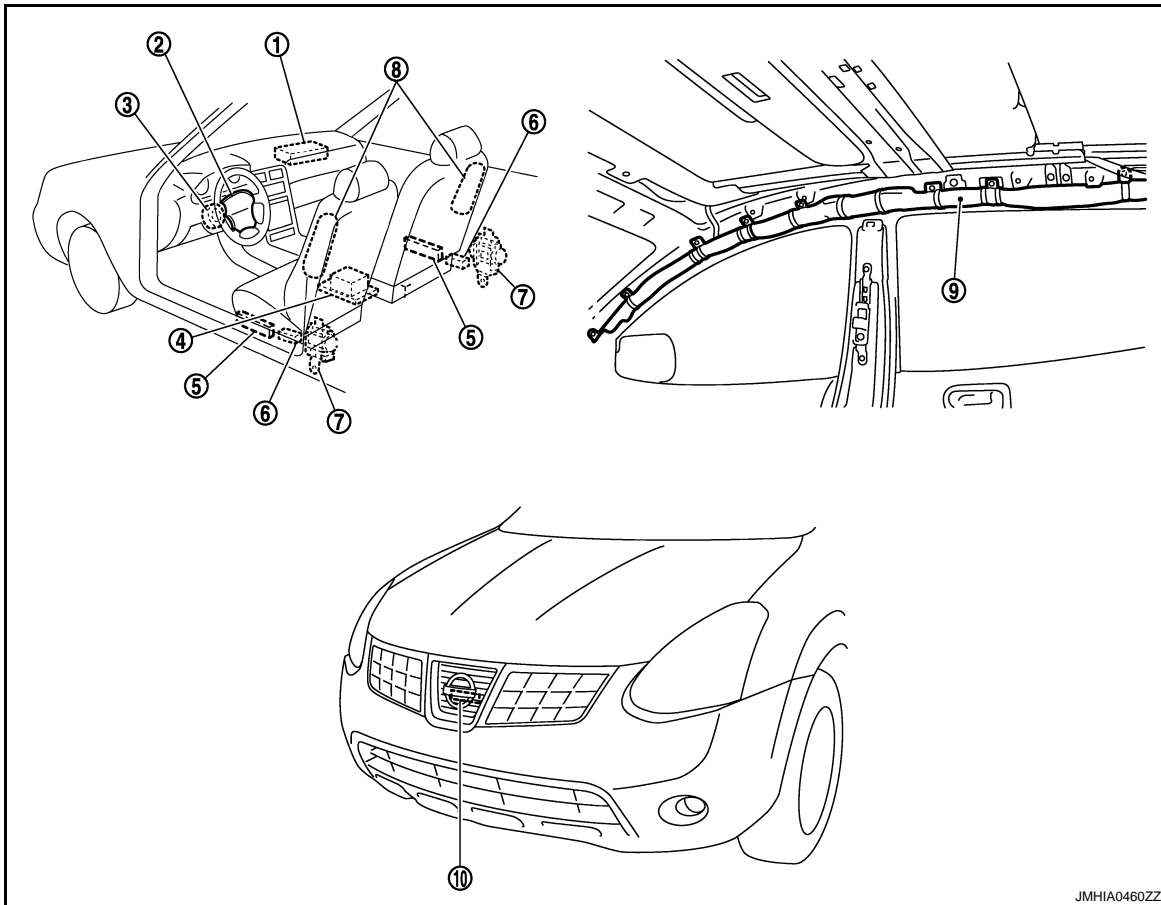

- |  |  |  |
|--|--|--|
| 1. Front passenger air bag module M70                          | 2. Driver air bag module M350                                    | 3. Combination switch (spiral cable) M32                     |
| 4. Air bag diagnosis sensor unit (ACU) B13, B14, M60           | 5. Front LH/RH seat belt pre-tensioner 2<br>• LH B31<br>• RH B42 | 6. LH/RH Air bag (satellite) sensor<br>• LH B37<br>• RH B30  |
| 7. Front LH/RH seat belt pre-tensioner<br>• LH B35<br>• RH B28 | 8. Front LH/RH side air bag module<br>• LH B16<br>• RH B18       | 9. LH/RH side curtain air bag module<br>• LH B72<br>• RH B56 |
| 10. Crash zone sensor E33                                      |  |  |

A  
B  
C  
D  
E  
F  
G  
H  
I  
J  
K  
L  
M  
N  
O  
P

SRC

# SRS AIR BAG SYSTEM

< SYSTEM DESCRIPTION >

[FOR MEXICO]

## Component Description

INFOID:000000005252844

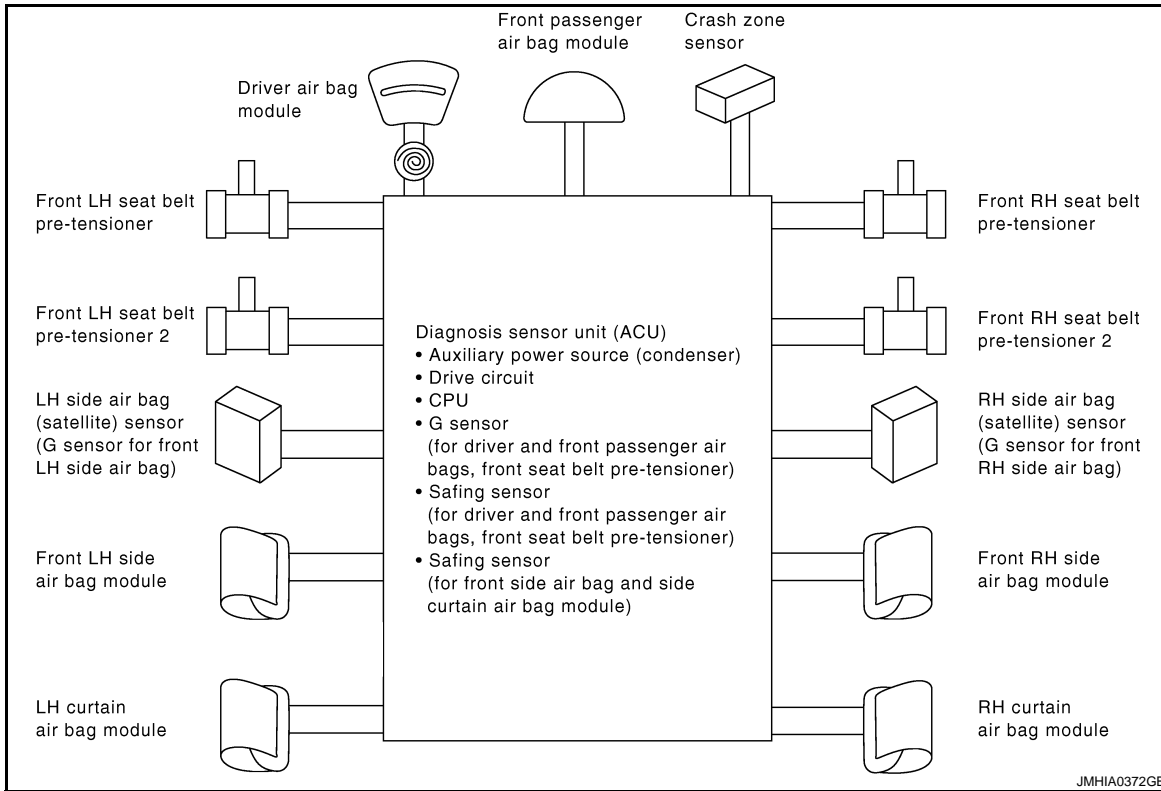

- Air bag sensor are prepared for operation while the ignition switch is in the ON or START position.
- The operation of supplemental restraint system is different from collision modes applications. For example, the driver air bag module and front passenger air bag module are activated in a frontal collision but not in a side collision.
- SRS configurations which are activated for some collision modes are as follows.

SRS configuration	Frontal collision	Left side collision	Right side collision
Driver air bag module.	×	—	—
Front passenger air bag module.	×	—	—
Front LH seat belt pre-tensioner.	×	—	—
Front RH seat belt pre-tensioner.	×	—	—
Front LH seat belt pre-tensioner 2.	×	—	—
Front RH seat belt pre-tensioner 2.	×	—	—
Front LH side air bag module.	—	×	—
Front RH side air bag module.	—	—	×
LH side curtain air bag module.	—	×	—
RH side curtain air bag module.	—	—	×

×: Application, —: Not application

## DIAGNOSIS SYSTEM (AIRBAG)

### Diagnosis Description

INFOID:000000005252845

**CAUTION:**

- Do not use electrical test equipment on any circuit related to the SRS unless instructed in this Service Manual. SRS wiring harnesses can be identified by yellow and/or orange harnesses or harness connectors.
- Do not repair, splice or modify the SRS wiring harness. If the harness is damaged, replace it with a new one.
- Keep ground portion clean.

### DIAGNOSIS FUNCTION

- The SRS self-diagnosis results can be read by using “AIR BAG” warning lamp and/or CONSULT-III.
- The user mode is exclusively prepared for the customer (driver). This mode warns the driver of a system malfunction through the operation of the “AIR BAG” warning lamp.
- The Diagnosis mode allows the technician to locate and inspect the malfunctioning part.
- The mode applications for the “AIR BAG” warning lamp and CONSULT-III are as follows.

	User mode	Diagnosis mode	Display type
“AIR BAG” warning lamp	X	X	ON-OFF operation
CONSULT-III	–	X	Monitoring

### HOW TO PERFORM TROUBLE DIAGNOSIS FOR QUICK AND ACCURATE REPAIR

A good understanding of the malfunction conditions can make troubleshooting faster and more accurate. In general, each customer feels differently about a malfunction. It is important to fully understand the symptoms or conditions for a customer complaint.

#### Information from Customer.

- WHAT..... Vehicle model.
- WHEN..... Date, Frequencies.
- WHERE..... Road conditions.
- HOW..... Operating conditions, Symptoms.

#### Preliminary Check.

Check that the following parts are in good order.

- Battery (Refer to [PG-3, "How to Handle Battery"](#)).
- Fuse (Refer to [SRC-311, "Wiring Diagram — SRS AIR BAG CONTROL SYSTEM —"](#)).
- System component-to-harness connections.

### HOW TO ERASE SELF-DIAGNOSTIC RESULTS (With CONSULT-III)

- “SELF-DIAG [CURRENT]”  
A current self-diagnosis result is displayed on CONSULT-III screen in real time. After the malfunction is repaired completely, no malfunction is detected on “SELF-DIAG [CURRENT]”.
- “SELF-DIAG [PAST]”  
Return to “SELF-DIAG [CURRENT]” CONSULT-III screen by touching “BACK” key of CONSULT-III and select “SELF-DIAG [CURRENT]” in SELECT DIAG MODE. Touch “ERASE” in “SELF-DIAG [CURRENT]” mode.

**NOTE:**

If the memory of the malfunction in “SELF-DIAG [PAST]” is not erased, the user mode shows the system malfunction by the operation of the warning lamp even if the malfunction is repaired completely.

- “TROUBLE DIAG RECORD”  
The memory of “TROUBLE DIAG RECORD” cannot be erased.

### HOW TO ERASE SELF-DIAGNOSTIC RESULTS (Without CONSULT-III)

After a malfunction is repaired, turn the ignition switch OFF for at least one second, then turn ignition switch ON diagnosis mode returns to the user mode. At that time the self-diagnosis result is cleared.

A  
B  
C  
D  
E  
F  
G  
I  
J  
K  
L  
M  
N  
O  
P

SRC

# DIAGNOSIS SYSTEM (AIRBAG)

[FOR MEXICO]

< SYSTEM DESCRIPTION >

## DIAGNOSTIC PROCEDURE (User mode)

Checking air bag operation according to "AIR BAG" Warning Lamp-User Mode

1. Turn the ignition switch from OFF to ON, and check that the air bag warning lamp blinks.
2. Compare the SRS air bag warning lamp blinking pattern with the examples.

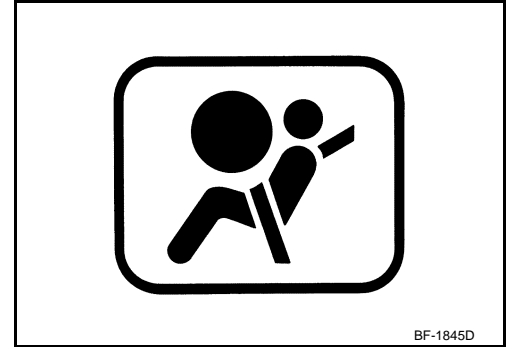

Warning lamp examples (User mode)

"AIR BAG" warning lamp operation -User mode	SRS condition	Reference item
<p>SHIA0011E</p>	<ul style="list-style-type: none"> <li>• No malfunction is detected.</li> <li>• No further action is necessary.</li> </ul>	—
<p>SHIA0012E</p>	<ul style="list-style-type: none"> <li>• The system is malfunctioning and needs to be repaired as indicated.</li> </ul>	Go to <a href="#">SRC-179. "Diagnosis Description"</a> .

# DIAGNOSIS SYSTEM (AIRBAG)

< SYSTEM DESCRIPTION >

[FOR MEXICO]

"AIR BAG" warning lamp operation -User mode	SRS condition	Reference item
<p>SHIA0013E</p>	<ul style="list-style-type: none"> <li>Air bag is deployed.</li> <li>Seat belt pre-tensioner is deployed.</li> </ul>	Go to <a href="#">SRC-299, "Diagnosis Procedure"</a> or <a href="#">SRC-301, "Diagnosis Procedure"</a> .
	<ul style="list-style-type: none"> <li>Diagnosis sensor unit is malfunctioning.</li> <li>Air bag power supply circuit is malfunctioning.</li> <li>SRS air bag warning lamp circuit is malfunctioning.</li> </ul>	Go to <a href="#">SRC-316, "Diagnosis Procedure"</a> .
<p>SHIA0014E</p>	<ul style="list-style-type: none"> <li>Diagnosis sensor unit is malfunctioning.</li> <li>Air bag warning lamp circuit is malfunctioning.</li> </ul>	Go to <a href="#">SRC-316, "Diagnosis Procedure"</a> .

A  
B  
C  
D  
E  
F  
G

SRC

## DIAGNOSTIC PROCEDURE (With CONSULT-III)

Diagnostic Mode	Description
SELF-DIAG RESULT	The self-diagnosis result is displayed. (SELF-DIAG [CURRENT], [PAST], [RECORD])
ECU DISCRIMINATED No.	The part number of diagnosis sensor unit is displayed.

I  
J

## CONSULT-III Function

INFOID:000000005252846

### DIAGNOSIS MODE FOR CONSULT-III

- "SELF-DIAG [CURRENT]"  
A current self-diagnosis results (also indicated with the number of warning lamp blinks in diagnosis mode) are displayed on CONSULT-III screen in real time. This refers to a malfunctioning part requiring repairs.
- "SELF-DIAG [PAST]"  
Diagnosis results previously stored in the memory are displayed on CONSULT-III screen. The stored results are not erased until memory erasing is executed.
- "TROUBLE DIAG RECORD"  
With TROUBLE DIAG RECORD, diagnosis results previously erased by a reset operation can be displayed on CONSULT-III screen.
- "ECU DISCRIMINATED NO."  
Air bag diagnosis sensor unit ECU discriminated number (identification number) is displayed. Air bag diagnosis sensor unit has individual ECU discriminated number (identification number) based on model and equipment.

K  
L  
M  
N  
O

### HOW TO CHANGE SELF-DIAGNOSIS MODE WITH CONSULT-III

#### From User Mode to Diagnosis Mode

After selecting "AIR BAG" on the "SELECT SYSTEM" screen, User mode automatically changes to Diagnosis mode.

#### From Diagnosis Mode to User Mode

To return to User mode from Diagnosis mode, touch "BACK" key of CONSULT-III until "SELECT SYSTEM" appears, then diagnosis mode automatically changes to User mode.

P

# DIAGNOSIS SYSTEM (AIRBAG)

< SYSTEM DESCRIPTION >

[FOR MEXICO]

## SELF-DIAGNOSIS FUNCTION (Without CONSULT-III)

- The reading of these results is accomplished by “User mode” and “Diagnosis mode”.
- After a malfunction is repaired, turn ignition switch ON. Diagnosis mode returns to the user mode. At that time, the self-diagnosis result is cleared.

## HOW TO CHANGE SELF-DIAGNOSIS MODE WITHOUT CONSULT-III

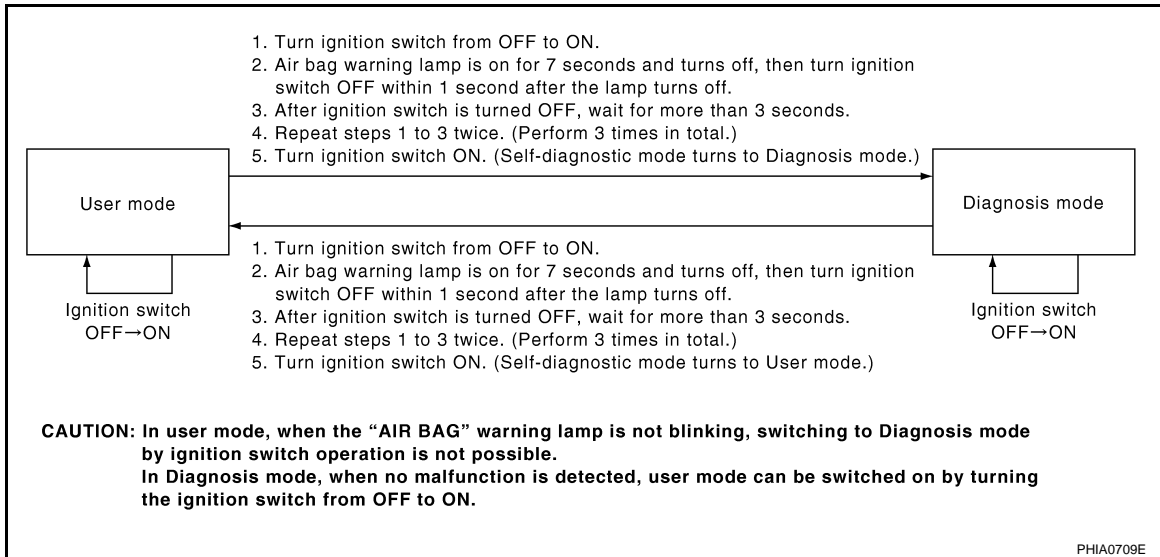

# B1001, B1002, B1003, B1004, B1005 DIAGNOSIS SENSOR UNIT

< DTC/CIRCUIT DIAGNOSIS >

[FOR MEXICO]

## DTC/CIRCUIT DIAGNOSIS

### B1001, B1002, B1003, B1004, B1005 DIAGNOSIS SENSOR UNIT

#### Description

INFOID:000000005252847

#### DTC B1001, B1002, B1003, B1004, B1005 DIAGNOSIS SENSOR UNIT

Detects the whole SRS electrical system and displays the malfunction either by illuminating or blinking the air bag warning lamp in the combination meter. Malfunctioning part can be detected by on board self-diagnosis system and electro-diagnosis tester CONSULT-III.

#### OPERATION

It detects a shock that exceeds specified level and monitors such systems as the driver and passenger air bag, side air bag, curtain air bag, pre-tensioner seat belts operate properly.

#### STRUCTURE

It contains the "G" sensors for both frontal and side collisions and spare battery function in case of main battery damage in collision.

#### INSTALLATION

SRS diagnosis sensor unit is installed under the center console with fixed bolts.

#### DTC Logic

INFOID:000000005252848

SRC

#### DTC DETECTION LOGIC

With CONSULT-III

DTC No. Index ("SELF-DIAG [CURRENT]"), ("SELF-DIAG [PAST]" or "TROUBLE DIAG RECORD")

DTC No.	Trouble diagnosis name	DTC detecting condition	Possible cause
B1001 B1002 B1003 B1004 B1005	CONTROL UNIT	Diagnosis sensor unit is out of order.	Internal breakdown in diagnosis sensor unit (ACU).

#### DTC CONFIRMATION PROCEDURE (With CONSULT-III)

##### 1.INSPECTION START

Turn ignition switch ON.

>> GO TO 2.

##### 2.CHECK SELF-DIAG RESULT

Check the screen of CONSULT-III.

Is malfunctioning part detected?

- YES >> Refer to [SRC-184, "Diagnosis Procedure"](#).
- NO >> **INSPECTION END.**

#### DTC CONFIRMATION PROCEDURE (Without CONSULT-III)

##### NOTE:

- SRS will not enter diagnosis mode if no malfunction is detected in user mode.

##### 1.INSPECTION START

Turn ignition switch ON.

# B1001, B1002, B1003, B1004, B1005 DIAGNOSIS SENSOR UNIT

[FOR MEXICO]

< DTC/CIRCUIT DIAGNOSIS >

---

>> GO TO 2.

## 2.CHECK AIR BAG WARNING LAMP

---

Check the warning lamp status.

Is malfunctioning part detected?

YES >> Refer to [SRC-303, "DTC Index"](#).

NO >> **INSPECTION END.**

## Diagnosis Procedure

INFOID:000000005252849

With CONSULT-III

### **WARNING:**

- Before servicing, turn ignition switch OFF, disconnect both battery terminals and wait at least 3 minutes. (To discharge backup capacitor.)
- Do not use unspecified tester or other measuring device.

## DIAGNOSTIC PROCEDURE

### 1.CHECK HARNESS CONNECTOR

---

Check the connection of harness connector.

Is the inspection result normal?

YES >> GO TO 2.

NO >> Repair or replace harness connectors.

### 2.CHECK WIRING HARNESS

---

Check the wiring harness externals.

Is the inspection result normal?

YES >> GO TO 3.

NO >> Repair or replace wiring harness.

### 3.CHECK DIAGNOSIS SENSOR UNIT

---

1. Replace diagnosis sensor unit (ACU).

2. Check the screen of CONSULT-III.

Is the inspection result normal?

YES >> **INSPECTION END.**

NO >> Check the intermittent incident. Refer to [GI-40, "Intermittent Incident"](#).



# B1006, B1007, B1008, B1009, B1010 DIAGNOSIS SENSOR UNIT

< DTC/CIRCUIT DIAGNOSIS >

[FOR MEXICO]

## B1006, B1007, B1008, B1009, B1010 DIAGNOSIS SENSOR UNIT

### Description

INFOID:000000005252850

#### DTC B1006, B1007, B1008, B1009, B1010 DIAGNOSIS SENSOR UNIT

Detects the whole SRS electrical system and displays the malfunction either by illuminating or blinking the air bag warning lamp in the combination meter. Malfunctioning part can be detected by on board self-diagnosis system and electro-diagnosis tester CONSULT-III.

### OPERATION

It detects a shock that exceeds specified level and monitors such systems as the driver and passenger air bag, side air bag, curtain air bag, pre-tensioner seat belts operate properly.

### STRUCTURE

It contains the "G" sensors for both frontal and side collisions and spare battery function in case of main battery damage in collision.

### INSTALLATION

SRS diagnosis sensor unit is installed under the center console with fixed bolts.

### DTC Logic

INFOID:000000005252851

#### DTC DETECTION LOGIC

With CONSULT-III

DTC No. Index ("SELF-DIAG [CURRENT]"), ("SELF-DIAG [PAST]" or "TROUBLE DIAG RECORD")

DTC No.	Trouble diagnosis name	DTC detecting condition	Possible cause
B1006 B1007 B1008 B1009 B1010	CONTROL UNIT	Diagnosis sensor unit is out of order.	Internal breakdown in diagnosis sensor unit (ACU).

#### DTC CONFIRMATION PROCEDURE (With CONSULT-III)

##### 1.INSPECTION START

Turn ignition switch ON.

>> GO TO 2.

##### 2.CHECK SELF-DIAG RESULT

Check the screen of CONSULT-III.

Is malfunctioning part detected?

YES >> Refer to [SRC-186, "Diagnosis Procedure"](#).

NO >> **INSPECTION END.**

#### DTC CONFIRMATION PROCEDURE (Without CONSULT-III)

##### NOTE:

- SRS will not enter diagnosis mode if no malfunction is detected in user mode.

##### 1.INSPECTION START

Turn ignition switch ON.

>> GO TO 2.

A  
B  
C  
D  
E  
F  
G  
I  
J  
K  
L  
M  
N  
O  
P

SRC

# B1006, B1007, B1008, B1009, B1010 DIAGNOSIS SENSOR UNIT

< DTC/CIRCUIT DIAGNOSIS >

[FOR MEXICO]

---

## 2.CHECK AIR BAG WARNING LAMP

---

Check the warning lamp status.

Is malfunctioning part detected?

YES >> Refer to [SRC-303, "DTC Index"](#).

NO >> **INSPECTION END.**

### Diagnosis Procedure

INFOID:000000005252852

With CONSULT-III

#### **WARNING:**

- **Before servicing, turn ignition switch OFF, disconnect both battery terminals and wait at least 3 minutes. (To discharge backup capacitor.)**
- **Do not use unspecified tester or other measuring device.**

### DIAGNOSTIC PROCEDURE

---

## 1.CHECK HARNESS CONNECTOR

---

Check the connection of harness connector.

Is the inspection result normal?

YES >> GO TO 2.

NO >> Repair or replace harness connectors.

---

## 2.CHECK WIRING HARNESS

---

Check the wiring harness externals.

Is the inspection result normal?

YES >> GO TO 3.

NO >> Repair or replace wiring harness.

---

## 3.CHECK DIAGNOSIS SENSOR UNIT

---

1. Replace diagnosis sensor unit (ACU).

2. Check the screen of CONSULT-III.

Is the inspection result normal?

YES >> **INSPECTION END.**

NO >> Check the intermittent incident. Refer to [GI-40, "Intermittent Incident"](#).

# B1011, B1012, B1013, B1014, B1015 DIAGNOSIS SENSOR UNIT

< DTC/CIRCUIT DIAGNOSIS >

[FOR MEXICO]

## B1011, B1012, B1013, B1014, B1015 DIAGNOSIS SENSOR UNIT

### Description

INFOID:000000005252853

### DTC B1011, B1012, B1013, B1014, B1015 DIAGNOSIS SENSOR UNIT

Detects the whole SRS electrical system and displays the malfunction either by illuminating or blinking the air bag warning lamp in the combination meter. Malfunctioning part can be detected by on board self-diagnosis system and electro-diagnosis tester CONSULT-III.

### OPERATION

It detects a shock that exceeds specified level and monitors such systems as the driver and passenger air bag, side air bag, curtain air bag, pre-tensioner seat belts operate properly.

### STRUCTURE

It contains the "G" sensors for both frontal and side collisions and spare battery function in case of main battery damage in collision.

### INSTALLATION

SRS diagnosis sensor unit is installed under the center console with fixed bolts.

### DTC Logic

INFOID:000000005252854

### DTC DETECTION LOGIC

With CONSULT-III

DTC No. Index ("SELF-DIAG [CURRENT]"), ("SELF-DIAG [PAST]" or "TROUBLE DIAG RECORD")

DTC No.	Trouble diagnosis name	DTC detecting condition	Possible cause
B1011 B1012 B1013 B1014 B1015	CONTROL UNIT	Diagnosis sensor unit is out of order.	Internal breakdown in diagnosis sensor unit (ACU).

### DTC CONFIRMATION PROCEDURE (With CONSULT-III)

#### 1.INSPECTION START

Turn ignition switch ON.

>> GO TO 2.

#### 2.CHECK SELF-DIAG RESULT

Check the screen of CONSULT-III.

Is malfunctioning part detected?

YES >> Refer to [SRC-188, "Diagnosis Procedure"](#).

NO >> **INSPECTION END.**

### DTC CONFIRMATION PROCEDURE (Without CONSULT-III)

#### NOTE:

- SRS will not enter diagnosis mode if no malfunction is detected in user mode.

#### 1.INSPECTION START

Turn ignition switch ON.

>> GO TO 2.

A

B

C

D

E

F

G

SRC

I

J

K

L

M

N

O

P

# B1011, B1012, B1013, B1014, B1015 DIAGNOSIS SENSOR UNIT

< DTC/CIRCUIT DIAGNOSIS >

[FOR MEXICO]

---

## 2.CHECK AIR BAG WARNING LAMP

---

Check the warning lamp status.

Is malfunctioning part detected?

YES >> Refer to [SRC-303, "DTC Index"](#).

NO >> **INSPECTION END.**

### Diagnosis Procedure

INFOID:000000005252855

With CONSULT-III

#### **WARNING:**

- Before servicing, turn ignition switch OFF, disconnect both battery terminals and wait at least 3 minutes. (To discharge backup capacitor.)
- Do not use unspecified tester or other measuring device.

### DIAGNOSTIC PROCEDURE

---

## 1.CHECK HARNESS CONNECTOR

---

Check the connection of harness connector.

Is the inspection result normal?

YES >> GO TO 2.

NO >> Repair or replace harness connectors.

---

## 2.CHECK WIRING HARNESS

---

Check the wiring harness externals.

Is the inspection result normal?

YES >> GO TO 3.

NO >> Repair or replace wiring harness.

---

## 3.CHECK DIAGNOSIS SENSOR UNIT

---

1. Replace diagnosis sensor unit (ACU).

2. Check the screen of CONSULT-III.

Is the inspection result normal?

YES >> **INSPECTION END.**

NO >> Check the intermittent incident. Refer to [GI-40, "Intermittent Incident"](#).

# B1026, B1027, B1028, B1029, B1030, B1031 DIAGNOSIS SENSOR UNIT

< DTC/CIRCUIT DIAGNOSIS >

[FOR MEXICO]

## B1026, B1027, B1028, B1029, B1030, B1031 DIAGNOSIS SENSOR UNIT

### Description

INFOID:000000005252856

### DTC B1026, B1027, B1028, B1029, B1030, B1031 DIAGNOSIS SENSOR UNIT

Detects the whole SRS electrical system and displays the malfunction either by illuminating or blinking the air bag warning lamp in the combination meter. Malfunctioning part can be detected by on board self-diagnosis system and electro-diagnosis tester CONSULT-III.

### OPERATION

It detects a shock that exceeds specified level and monitors such systems as the driver and passenger air bag, side air bag, curtain air bag, pre-tensioner seat belts operate properly.

### STRUCTURE

It contains the "G" sensors for both frontal and side collisions and spare battery function in case of main battery damage in collision.

### INSTALLATION

SRS diagnosis sensor unit is installed under the center console with fixed bolts.

### DTC Logic

INFOID:000000005252857

### DTC DETECTION LOGIC

With CONSULT-III

DTC No. Index ("SELF-DIAG [CURRENT]"), ("SELF-DIAG [PAST]" or "TROUBLE DIAG RECORD")

DTC No.	Trouble diagnosis name	DTC detecting condition	Possible cause
B1026 B1027 B1028 B1029 B1030 B1031	CONTROL UNIT	Diagnosis sensor unit is out of order.	Internal breakdown in diagnosis sensor unit (ACU).

### DTC CONFIRMATION PROCEDURE (With CONSULT-III)

#### 1.INSPECTION START

Turn ignition switch ON.

>> GO TO 2.

#### 2.CHECK SELF-DIAG RESULT

Check the screen of CONSULT-III.

Is malfunctioning part detected?

- YES >> Refer to [SRC-190. "Diagnosis Procedure"](#).
- NO >> **INSPECTION END.**

### DTC CONFIRMATION PROCEDURE (Without CONSULT-III)

#### NOTE:

- SRS will not enter diagnosis mode if no malfunction is detected in user mode.

#### 1.INSPECTION START

Turn ignition switch ON.

A  
B  
C  
D  
E  
F  
G  
I  
J  
K  
L  
M  
N  
O  
P

SRC

# B1026, B1027, B1028, B1029, B1030, B1031 DIAGNOSIS SENSOR UNIT

[FOR MEXICO]

< DTC/CIRCUIT DIAGNOSIS >

---

>> GO TO 2.

## 2.CHECK AIR BAG WARNING LAMP

---

Check the warning lamp status.

Is malfunctioning part detected?

YES >> Refer to [SRC-303, "DTC Index"](#).

NO >> **INSPECTION END.**

## Diagnosis Procedure

INFOID:000000005252858

With CONSULT-III

### **WARNING:**

- **Before servicing, turn ignition switch OFF, disconnect both battery terminals and wait at least 3 minutes. (To discharge backup capacitor.)**
- **Do not use unspecified tester or other measuring device.**

## DIAGNOSTIC PROCEDURE

### 1.CHECK HARNESS CONNECTOR

---

Check the connection of harness connector.

Is the inspection result normal?

YES >> GO TO 2.

NO >> Repair or replace harness connectors.

### 2.CHECK WIRING HARNESS

---

Check the wiring harness externals.

Is the inspection result normal?

YES >> GO TO 3.

NO >> Replace wiring harness.

### 3.CHECK DIAGNOSIS SENSOR UNIT

---

1. Replace diagnosis sensor unit (ACU).

2. Check the screen of CONSULT-III.

Is the inspection result normal?

YES >> **INSPECTION END.**

NO >> Check the intermittent incident. Refer to [GI-40, "Intermittent Incident"](#).

# B1033, B1034 CRASH ZONE SEN

< DTC/CIRCUIT DIAGNOSIS >

[FOR MEXICO]

## B1033, B1034 CRASH ZONE SEN

### Description

INFOID:000000005252859

### DTC B1033, B1034 [UNIT FAIL] CRASH ZONE SENSOR

Main "G" sensor generates signal voltage, when it detects deceleration beyond the specified level caused by vehicle frontal collision.

### OPERATION

When ACU define the both signal voltage of the "G" sensor and the safing sensor to be that of collision which exceeds specified level, the driving circuit switches on and feeds the electric ignitor of both driver and passenger air bags and pre-tensioner seat belt.

### STRUCTURE

Integrated type of the "G" sensor element for frontal collision with output terminals for signal voltage.

### INSTALLATION

Crash zone sensor is installed on the radiator core support assembly with fixed nuts.

### DTC Logic

INFOID:000000005252860

### DTC DETECTION LOGIC

With CONSULT-III

DTC No. Index ("SELF-DIAG [CURRENT]"), ("SELF-DIAG [PAST]" or "TROUBLE DIAG RECORD)

DTC No.	Trouble diagnosis name	DTC detecting condition	Possible cause
B1033 B1034	CRASH ZONE SENSOR [UNIT FAIL]	Crash zone sensor is out of order.	<ul style="list-style-type: none"><li>• Disconnection of wiring harness.</li><li>• Internal breakdown in crash zone sensor.</li><li>• Internal breakdown in diagnosis sensor unit (ACU).</li></ul>

### DTC CONFIRMATION PROCEDURE (With CONSULT-III)

#### 1.INSPECTION START

Turn ignition switch ON.

>> GO TO 2.

#### 2.CHECK SELF-DIAG RESULT

Check the screen of CONSULT-III.

Is malfunctioning part detected?

- YES >> Refer to [SRC-192, "Diagnosis Procedure"](#).
- NO >> **INSPECTION END.**

### DTC CONFIRMATION PROCEDURE (Without CONSULT-III)

#### NOTE:

- SRS will not enter diagnosis mode if no malfunction is detected in user mode.

#### 1.INSPECTION START

Turn ignition switch ON.

>> GO TO 2.

< DTC/CIRCUIT DIAGNOSIS >

---

## 2.CHECK AIR BAG WARNING LAMP-

---

Check the warning lamp status.

Is malfunctioning part detected?

- YES >> Refer to [SRC-303, "DTC Index"](#).  
NO >> **INSPECTION END.**

### Diagnosis Procedure

INFOID:000000005252861

With CONSULT-III

#### **WARNING:**

- Before servicing, turn ignition switch OFF, disconnect both battery terminals and wait at least 3 minutes. (To discharge backup capacitor.)
- Do not use unspecified tester or other measuring device.

### DIAGNOSTIC PROCEDURE

---

## 1.CHECK HARNESS CONNECTOR

---

Check the connection of harness connector.

Is the inspection result normal?

- YES >> GO TO 2.  
NO >> Repair or replace harness connectors.

---

## 2.CHECK WIRING HARNESS

---

Check the wiring harness externals.

Is the inspection result normal?

- YES >> GO TO 3.  
NO >> Repair or replace wiring harness.

---

## 3.CHECK CRASH ZONE SENSOR

---

1. Replace crash zone sensor.
2. Check the screen of CONSULT-III.

Is the inspection result normal?

- YES >> **INSPECTION END.**  
NO >> Check the intermittent incident. Refer to [GI-40, "Intermittent Incident"](#).



# B1035, B1036, B1038, B1040 CRASH ZONE SEN

< DTC/CIRCUIT DIAGNOSIS >

[FOR MEXICO]

## B1035, B1036, B1038, B1040 CRASH ZONE SEN

### Description

INFOID:000000005252862

### DTC B1035, B1036, B1038, B1040 [COMM FAIL] CRASH ZONE SENSOR

Main "G" sensor that generates signal voltage, when it detects deceleration beyond the specified level caused by vehicle frontal collision.

### OPERATION

When ACU defines both signal voltage of the "G" sensor and the safing sensor to be that of collision which exceeds specified level, the driving circuit switches on and feeds the electric ignitor of both driver and passenger air bags and pre-tensioner seat belt.

### STRUCTURE

Integrated type of the "G" sensor element for frontal collision with output terminals for signal voltage.

### INSTALLATION

Crash zone sensor is installed on the radiator core support assembly with fixed nuts.

### DTC Logic

INFOID:000000005252863

### DTC DETECTION LOGIC

With CONSULT-III

DTC No. Index ("SELF-DIAG [CURRENT]"), ("SELF-DIAG [PAST]" or "TROUBLE DIAG RECORD")

DTC No.	Trouble diagnosis name	DTC detecting condition	Possible cause
B1035	CRASH ZONE SENSOR [COMM FAIL]	Crash zone sensor is out of order.	<ul style="list-style-type: none"><li>• Disconnection of wiring harness and open/short.</li><li>• Internal breakdown in crash zone sensor.</li><li>• Internal breakdown in diagnosis sensor unit (ACU).</li></ul>
B1036	[UNMATCH]		
B1038	[OPEN/UPR-VB-SHORT]		
B1040	[SHORT/UPR-GND-SHORT]		

### DTC CONFIRMATION PROCEDURE (With CONSULT-III)

#### 1.INSPECTION START

Turn ignition switch ON.

>> GO TO 2.

#### 2.CHECK SELF-DIAG RESULT

Check the screen of CONSULT-III.

Is malfunctioning part detected?

- YES >> Refer to [SRC-194. "Diagnosis Procedure"](#).  
NO >> **INSPECTION END.**

### DTC CONFIRMATION PROCEDURE (Without CONSULT-III)

#### NOTE:

- SRS will not enter diagnosis mode if no malfunction is detected in user mode.

#### 1.INSPECTION START

Turn ignition switch ON.

>> GO TO 2.

## 2.CHECK AIR BAG WARNING LAMP

---

Check the warning lamp status.

Is malfunctioning part detected?

YES >> Refer to [SRC-303, "DTC Index"](#).

NO >> **INSPECTION END.**

## Diagnosis Procedure

INFOID:000000005252864

With CONSULT-III

### **WARNING:**

- Before servicing, turn ignition switch OFF, disconnect both battery terminals and wait at least 3 minutes. (To discharge backup capacitor.)
- Do not use unspecified tester or other measuring device.

## DIAGNOSTIC PROCEDURE

### 1.CHECK HARNESS CONNECTOR

---

Check the connection of harness connector.

Is the inspection result normal?

YES >> GO TO 2.

NO >> Repair or replace harness connectors.

### 2.CHECK WIRING HARNESS

---

Check the wiring harness externals.

Is the inspection result normal?

YES >> GO TO 3.

NO >> Repair or replace wiring harness.

### 3.CHECK CRASH ZONE SENSOR

---

1. Replace crash zone sensor.
2. Check the screen of CONSULT-III.

Is the inspection result normal?

YES >> **INSPECTION END.**

NO >> Check the intermittent incident. Refer to [GI-40, "Intermittent Incident"](#).

# B1042, B1043, B1044, B1045, B1046, B1047 DIAGNOSIS SENSOR UNIT

< DTC/CIRCUIT DIAGNOSIS >

[FOR MEXICO]

## B1042, B1043, B1044, B1045, B1046, B1047 DIAGNOSIS SENSOR UNIT

### Description

INFOID:000000005252865

#### DTC B1042, B1043, B1044, B1045, B1046, B1047 DIAGNOSIS SENSOR UNIT

Detects the whole SRS electrical system and displays the malfunction either by illuminating or blinking the air bag warning lamp in the combination meter. Malfunctioning part can be detected by on board self-diagnosis system and electro-diagnosis tester CONSULT-III.

### OPERATION

It detects a shock that exceeds specified level and monitors such systems as the driver and passenger air bag, side air bag, curtain air bag, pre-tensioner seat belts operate properly.

### STRUCTURE

It contains the "G" sensors for both for frontal and side collisions and spare battery function in case of main battery damage in collision.

### INSTALLATION

SRS diagnosis sensor unit is installed under the center console with fixed bolts.

### DTC Logic

INFOID:000000005252866

#### DTC DETECTION LOGIC

With CONSULT-III

DTC No. Index ("SELF-DIAG [CURRENT]"), ("SELF-DIAG [PAST]" or "TROUBLE DIAG RECORD")

DTC No.	Trouble diagnosis name	DTC detecting condition	Possible cause
B1042 B1043 B1044 B1045 B1046 B1047	CONTROL UNIT	Diagnosis sensor unit is out of order.	Internal breakdown in diagnosis sensor unit (ACU).

#### DTC CONFIRMATION PROCEDURE (With CONSULT-III)

##### 1.INSPECTION START

Turn ignition switch ON.

>> GO TO 2.

##### 2.CHECK SELF-DIAG RESULT

Check the screen of CONSULT-III.

Is malfunctioning part detected?

- YES >> Refer to [SRC-196. "Diagnosis Procedure"](#).
- NO >> **INSPECTION END.**

#### DTC CONFIRMATION PROCEDURE (Without CONSULT-III)

##### NOTE:

- SRS will not enter diagnosis mode if no malfunction is detected in user mode.

##### 1.INSPECTION START

Turn ignition switch ON.

A  
B  
C  
D  
E  
F  
G  
I  
J  
K  
L  
M  
N  
O  
P

SRC

# B1042, B1043, B1044, B1045, B1046, B1047 DIAGNOSIS SENSOR UNIT

< DTC/CIRCUIT DIAGNOSIS >

[FOR MEXICO]

>> GO TO 2.

## 2.CHECK AIR BAG WARNING LAMP

Check the warning lamp status.

Is malfunctioning part detected?

YES >> Refer to [SRC-303, "DTC Index"](#).

NO >> **INSPECTION END.**

## Diagnosis Procedure

INFOID:000000005252867

With CONSULT-III

### **WARNING:**

- **Before servicing, turn ignition switch OFF, disconnect both battery terminals and wait at least 3 minutes. (To discharge backup capacitor.)**
- **Do not use unspecified tester or other measuring device.**

## DIAGNOSTIC PROCEDURE

### 1.CHECK HARNESS CONNECTOR

Check the connection of harness connector.

Is the inspection result normal?

YES >> GO TO 2.

NO >> Repair or replace harness connectors.

### 2.CHECK WIRING HARNESS

Check the wiring harness externals.

Is the inspection result normal?

YES >> GO TO 3.

NO >> Repair or replace wiring harness.

### 3.CHECK DIAGNOSIS SENSOR UNIT

1. Replace diagnosis sensor unit (ACU).

2. Check the screen of CONSULT-III.

Is the inspection result normal?

YES >> **INSPECTION END.**

NO >> Check the intermittent incident. Refer to [GI-40, "Intermittent Incident"](#).

# B1049 DRIVER AIRBAG MODULE

< DTC/CIRCUIT DIAGNOSIS >

[FOR MEXICO]

## B1049 DRIVER AIRBAG MODULE

### Description

INFOID:000000005252868

### DTC B1049 [OPEN] DRIVER AIRBAG MODULE

For driver air bag module, crash is judged by main "G" sensor output signal and sub "G" sensor in front direction.

### OPERATION

In the case of a frontal collision whose acceleration exceeds the specified level, the ignition materials are ignited by electric ignition system. The system burns and introduces the chemical reaction of gas generating materials to generate hot gases that flow into the air bag through a filter and expand the bag.

### STRUCTURE

Driver air bag module mainly consists of air bag and inflator which inflates air bag.

### INSTALLATION

Driver air bag module is installed on the center of steering wheel with fixed bolts.

### DTC Logic

INFOID:000000005252869

### DTC DETECTION LOGIC

With CONSULT-III

DTC No. Index ("SELF-DIAG [CURRENT]"), ("SELF-DIAG [PAST]" or "TROUBLE DIAG RECORD")

DTC No.	Trouble diagnosis name	DTC detecting condition	Possible cause
B1049	DRIVER AIRBAG MODULE [OPEN]	Driver air bag module circuit is open. (including the spiral cable.)	<ul style="list-style-type: none"><li>• Disconnection of wiring harness and open.</li><li>• Internal breakdown in driver air bag module.</li><li>• Internal breakdown in spiral cable.</li><li>• Internal breakdown in diagnosis sensor unit (ACU).</li></ul>

### DTC CONFIRMATION PROCEDURE (With CONSULT-III)

#### 1.INSPECTION START

Turn ignition switch ON.

>> GO TO 2.

#### 2.CHECK SELF-DIAG RESULT

Check the screen of CONSULT-III.

Is malfunctioning part detected?

- YES >> Refer to [SRC-198. "Diagnosis Procedure"](#).  
NO >> **INSPECTION END.**

### DTC CONFIRMATION PROCEDURE (Without CONSULT-III)

#### NOTE:

- SRS will not enter diagnosis mode if no malfunction is detected in user mode.

#### 1.INSPECTION START

Turn ignition switch ON.

A

B

C

D

E

F

G

SRC

I

J

K

L

M

N

O

P

# B1049 DRIVER AIRBAG MODULE

[FOR MEXICO]

< DTC/CIRCUIT DIAGNOSIS >

>> GO TO 2.

## 2.CHECK AIR BAG WARNING LAMP

Check the warning lamp status.

Is malfunctioning part detected?

YES >> Refer to [SRC-303, "DTC Index"](#).

NO >> **INSPECTION END.**

## Diagnosis Procedure

INFOID:000000005252870

With CONSULT-III

### **WARNING:**

- **Before servicing, turn ignition switch OFF, disconnect both battery terminals and wait at least 3 minutes. (To discharge backup capacitor.)**
- **Do not use unspecified tester or other measuring device.**

## DIAGNOSTIC PROCEDURE

### 1.CHECK HARNESS CONNECTOR

Check the connection of harness connector.

Is the inspection result normal?

YES >> GO TO 2.

NO >> Repair or replace harness connector.

### 2.CHECK WIRING HARNESS

Check the wiring harness externals.

Is the inspection result normal?

YES >> GO TO 3.

NO >> Repair or replace wiring harness.

### 3.CHECK DRIVER AIR BAG MODULE

1. Replace driver air bag module.
2. Check the screen of CONSULT-III.

Is the inspection result normal?

YES >> **INSPECTION END.**

NO >> GO TO 4.

### 4.CHECK SPIRAL CABLE CIRCUIT

1. Turn ignition switch OFF.
2. Disconnect driver side air bag module harness connector and body side harness connector.
3. Check continuity between driver side air bag module harness connector and body side harness connector.

Driver side air bag module harness connector	Terminal	Body side harness connector	Terminal	Continuity
M350	10 11	M32	30 23	Existed

4. Check continuity between driver side air bag module harness connector and ground.

Driver side air bag module harness connector	Terminal	Ground	Continuity
M350	10 11	Ground	Not existed

Is the inspection result normal?

YES >> Check the intermittent incident. Refer to [GI-40, "Intermittent Incident"](#).

NO >> Replace spiral cable.

# B1050 DRIVER AIRBAG MODULE

< DTC/CIRCUIT DIAGNOSIS >

[FOR MEXICO]

## B1050 DRIVER AIRBAG MODULE

### Description

INFOID:000000005252871

### DTC B1050 [VB-SHORT] DRIVER AIRBAG MODULE

For driver air bag module, crash is judged by main “G” sensor output signal and sub “G” sensor in front direction.

### OPERATION

In the case of a frontal collision whose acceleration exceeds the specified level, the ignition materials are ignited by electric ignition system. The system burns and introduces the chemical reaction of gas generating materials to generate hot gases that flow into the air bag through a filter and expand the bag.

### STRUCTURE

Driver air bag module mainly consists of air bag and inflator which inflates air bag.

### INSTALLATION

Driver air bag module is installed on the center of steering wheel with fixed bolts.

### DTC Logic

INFOID:000000005252872

### DTC DETECTION LOGIC

With CONSULT-III

DTC No. Index (“SELF-DIAG [CURRENT]”), (“SELF-DIAG [PAST]” or “TROUBLE DIAG RECORD”)

DTC No.	Trouble diagnosis name	DTC detecting condition	Possible cause
B1050	DRIVER AIRBAG MODULE [VB-SHORT]	Driver air bag module circuit is shorted to some power supply circuit. (including the spiral cable.)	<ul style="list-style-type: none"><li>• Disconnection of wiring harness and short.</li><li>• Internal breakdown in driver air bag module.</li><li>• Internal breakdown in spiral cable.</li><li>• Internal breakdown in diagnosis sensor unit (ACU).</li></ul>

### DTC CONFIRMATION PROCEDURE (With CONSULT-III)

#### 1.INSPECTION START

Turn ignition switch ON.

>> GO TO 2.

#### 2.CHECK SELF-DIAG RESULT

Check the screen of CONSULT-III.

Is malfunctioning part detected?

YES >> Refer to [SRC-200. "Diagnosis Procedure"](#).

NO >> **INSPECTION END.**

### DTC CONFIRMATION PROCEDURE (Without CONSULT-III)

#### NOTE:

- SRS will not enter diagnosis mode if no malfunction is detected in user mode.

#### 1.INSPECTION START

Turn ignition switch ON.

# B1050 DRIVER AIRBAG MODULE

[FOR MEXICO]

< DTC/CIRCUIT DIAGNOSIS >

>> GO TO 2.

## 2.CHECK AIR BAG WARNING LAMP

Check the warning lamp status.

Is malfunctioning part detected?

YES >> Refer to [SRC-303, "DTC Index"](#).

NO >> **INSPECTION END.**

## Diagnosis Procedure

INFOID:000000005252873

With CONSULT-III

### **WARNING:**

- **Before servicing, turn ignition switch OFF, disconnect both battery terminals and wait at least 3 minutes. (To discharge backup capacitor.)**
- **Do not use unspecified tester or other measuring device.**

## DIAGNOSTIC PROCEDURE

### 1.CHECK HARNESS CONNECTOR

Check the connection of harness connector.

Is the inspection result normal?

YES >> GO TO 2.

NO >> Repair or replace harness connector.

### 2.CHECK WIRING HARNESS

Check the wiring harness externals.

Is the inspection result normal?

YES >> GO TO 3.

NO >> Repair or replace wiring harness.

### 3.CHECK DRIVER AIR BAG MODULE

1. Replace driver air bag module.
2. Check the screen of CONSULT-III.

Is the inspection result normal?

YES >> **INSPECTION END.**

NO >> GO TO 4.

### 4.CHECK SPIRAL CABLE CIRCUIT

1. Turn ignition switch OFF.
2. Disconnect driver side air bag module harness connector and body side harness connector.
3. Check continuity between driver side air bag module harness connector and body side harness connector.

Driver side air bag module harness connector	Terminal	Body side harness connector	Terminal	Continuity
M350	10 11	M32	30 23	Existed

4. Check continuity between driver side air bag module harness connector and ground.

Driver side air bag module harness connector	Terminal	Ground	Continuity
M350	10 11	Ground	Not existed

Is the inspection result normal?

YES >> Check the intermittent incident. Refer to [GI-40, "Intermittent Incident"](#).

NO >> Replace spiral cable.



# B1051 DRIVER AIRBAG MODULE

< DTC/CIRCUIT DIAGNOSIS >

[FOR MEXICO]

## B1051 DRIVER AIRBAG MODULE

### Description

INFOID:000000005252874

### DTC B1051 [GND-SHORT] DRIVER AIRBAG MODULE

For driver air bag module, crash is judged by main “G” sensor output signal and sub “G” sensor in front direction.

### OPERATION

In the case of a frontal collision whose acceleration exceeds the specified level, the ignition materials are ignited by electric ignition system. The system burns and introduces the chemical reaction of gas generating materials to generate hot gases that flow into the air bag through a filter and expand the bag.

### STRUCTURE

Driver air bag module mainly consists of air bag and inflator which inflates air bag.

### INSTALLATION

Driver air bag module is installed on the center of steering wheel with fixed bolts.

### DTC Logic

INFOID:000000005252875

### DTC DETECTION LOGIC

With CONSULT-III

DTC No. Index (“SELF-DIAG [CURRENT]”), (“SELF-DIAG [PAST]” or “TROUBLE DIAG RECORD”)

SRC

DTC No.	Trouble diagnosis name	DTC detecting condition	Possible cause
B1051	DRIVER AIRBAG MODULE [GND-SHORT]	Driver air bag module circuit is shorted to ground. (including the spiral cable.)	<ul style="list-style-type: none"><li>• Disconnection of wiring harness and short.</li><li>• Internal breakdown in driver air bag module.</li><li>• Internal breakdown in spiral cable.</li><li>• Internal breakdown in diagnosis sensor unit (ACU).</li></ul>

### DTC CONFIRMATION PROCEDURE (With CONSULT-III)

#### 1.INSPECTION START

Turn ignition switch ON.

>> GO TO 2.

#### 2.CHECK SELF-DIAG RESULT

Check the screen of CONSULT-III.

Is malfunctioning part detected?

YES >> Refer to [SRC-202. "Diagnosis Procedure"](#).

NO >> **INSPECTION END.**

### DTC CONFIRMATION PROCEDURE (Without CONSULT-III)

#### NOTE:

- SRS will not enter diagnosis mode if no malfunction is detected in user mode.

#### 1.INSPECTION START

Turn ignition switch ON.

# B1051 DRIVER AIRBAG MODULE

[FOR MEXICO]

< DTC/CIRCUIT DIAGNOSIS >

>> GO TO 2.

## 2.CHECK AIR BAG WARNING LAMP

Check the warning lamp status.

Is malfunctioning part detected?

YES >> Refer to [SRC-303, "DTC Index"](#).

NO >> **INSPECTION END.**

## Diagnosis Procedure

INFOID:000000005252876

With CONSULT-III

### **WARNING:**

- **Before servicing, turn ignition switch OFF, disconnect both battery terminals and wait at least 3 minutes. (To discharge backup capacitor.)**
- **Do not use unspecified tester or other measuring device.**

## DIAGNOSTIC PROCEDURE

### 1.CHECK HARNESS CONNECTOR

Check the connection of harness connector.

Is the inspection result normal?

YES >> GO TO 2.

NO >> Repair or replace harness connector.

### 2.CHECK WIRING HARNESS

Check the wiring harness externals.

Is the inspection result normal?

YES >> GO TO 3.

NO >> Repair or replace wiring harness.

### 3.CHECK DRIVER AIR BAG MODULE

1. Replace driver air bag module.
2. Check the screen of CONSULT-III.

Is the inspection result normal?

YES >> **INSPECTION END.**

NO >> GO TO 4.

### 4.CHECK SPIRAL CABLE CIRCUIT

1. Turn ignition switch OFF.
2. Disconnect driver side air bag module harness connector and body side harness connector.
3. Check continuity between driver side air bag module harness connector and body side harness connector.

Driver side air bag module harness connector	Terminal	Body side harness connector	Terminal	Continuity
M350	10 11	M32	30 23	Existed

4. Check continuity between driver side air bag module harness connector and ground.

Driver side air bag module harness connector	Terminal	Ground	Continuity
M350	10 11	Ground	Not existed

Is the inspection result normal?

YES >> Check the intermittent incident. Refer to [GI-40, "Intermittent Incident"](#).

NO >> Replace spiral cable.

# B1052 DRIVER AIRBAG MODULE

< DTC/CIRCUIT DIAGNOSIS >

[FOR MEXICO]

## B1052 DRIVER AIRBAG MODULE

### Description

INFOID:000000005252877

### DTC B1052 [SHORT] DRIVER AIRBAG MODULE

For driver air bag module, crash is judged by main “G” sensor output signal and sub “G” sensor in front direction.

### OPERATION

In the case of a frontal collision whose acceleration exceeds the specified level, the ignition materials are ignited by electric ignition system. The system burns and introduces the chemical reaction of gas generating materials to generate hot gases that flow into the air bag through a filter and expand the bag.

### STRUCTURE

Driver air bag module mainly consists of air bag and inflator which inflates air bag.

### INSTALLATION

Driver air bag module is installed on the center of steering wheel with fixed bolts.

### DTC Logic

INFOID:000000005252878

### DTC DETECTION LOGIC

With CONSULT-III

DTC No. Index (“SELF-DIAG [CURRENT]”), (“SELF-DIAG [PAST]” or “TROUBLE DIAG RECORD”)

SRC

DTC No.	Trouble diagnosis name	DTC detecting condition	Possible cause
B1052	DRIVER AIRBAG MODULE [SHORT]	Driver air bag module circuit are shorted to each other. (including the spiral cable.)	<ul style="list-style-type: none"><li>• Disconnection of wiring harness and short.</li><li>• Internal breakdown in driver air bag module.</li><li>• Internal breakdown in spiral cable.</li><li>• Internal breakdown in diagnosis sensor unit (ACU).</li></ul>

### DTC CONFIRMATION PROCEDURE (With CONSULT-III)

#### 1.INSPECTION START

Turn ignition switch ON.

>> GO TO 2.

#### 2.CHECK SELF-DIAG RESULT

Check the screen of CONSULT-III.

Is malfunctioning part detected?

YES >> Refer to [SRC-204. "Diagnosis Procedure"](#).

NO >> **INSPECTION END.**

### DTC CONFIRMATION PROCEDURE (Without CONSULT-III)

#### NOTE:

- SRS will not enter diagnosis mode if no malfunction is detected in user mode.

#### 1.INSPECTION START

Turn ignition switch ON.

# B1052 DRIVER AIRBAG MODULE

[FOR MEXICO]

< DTC/CIRCUIT DIAGNOSIS >

>> GO TO 2.

## 2.CHECK AIR BAG WARNING LAMP

Check the warning lamp status.

Is malfunctioning part detected?

YES >> Refer to [SRC-303, "DTC Index"](#).

NO >> **INSPECTION END.**

## Diagnosis Procedure

INFOID:000000005252879

With CONSULT-III

### **WARNING:**

- **Before servicing, turn ignition switch OFF, disconnect both battery terminals and wait at least 3 minutes. (To discharge backup capacitor.)**
- **Do not use unspecified tester or other measuring device.**

## DIAGNOSTIC PROCEDURE

### 1.CHECK HARNESS CONNECTOR

Check the connection of harness connector.

Is the inspection result normal?

YES >> GO TO 2.

NO >> Repair or replace harness connector.

### 2.CHECK WIRING HARNESS

Check the wiring harness externals.

Is the inspection result normal?

YES >> GO TO 3.

NO >> Repair or replace wiring harness.

### 3.CHECK DRIVER AIR BAG MODULE

1. Replace driver air bag module.
2. Check the screen of CONSULT-III.

Is the inspection result normal?

YES >> **INSPECTION END.**

NO >> GO TO 4.

### 4.CHECK SPIRAL CABLE CIRCUIT

1. Turn ignition switch OFF.
2. Disconnect driver side air bag module harness connector and body side harness connector.
3. Check continuity between driver side air bag module harness connector and body side harness connector.

Driver side air bag module harness connector	Terminal	Body side harness connector	Terminal	Continuity
M350	10 11	M32	30 23	Existed

4. Check continuity between driver side air bag module harness connector and ground.

Driver side air bag module harness connector	Terminal	Ground	Continuity
M350	10 11	Ground	Not existed

Is the inspection result normal?

YES >> Check the intermittent incident. Refer to [GI-40, "Intermittent Incident"](#).

NO >> Replace spiral cable.

# B1058, B1059, B1060, B1061, B1062, B1063 DIAGNOSIS SENSOR UNIT

< DTC/CIRCUIT DIAGNOSIS >

[FOR MEXICO]

## B1058, B1059, B1060, B1061, B1062, B1063 DIAGNOSIS SENSOR UNIT

### Description

INFOID:000000005252880

#### DTC B1058, B1059, B1060, B1061, B1062, B1063 DIAGNOSIS SENSOR UNIT

Detects the whole SRS electrical system and displays the malfunction either by illuminating or blinking the air bag warning lamp in the combination meter. Malfunctioning part can be detected by on board self-diagnosis system and electro-diagnosis tester CONSULT-III.

### OPERATION

It detects a shock that exceeds specified level and monitors such systems as the driver and passenger air bag, side air bag, curtain air bag, pre-tensioner seat belts operate properly.

### STRUCTURE

It contains the "G" sensors for both frontal and side collisions and spare battery function in case of main battery damage in collision.

### INSTALLATION

SRS diagnosis sensor unit is installed under the center console with fixed bolts.

### DTC Logic

INFOID:000000005252881

#### DTC DETECTION LOGIC

With CONSULT-III

DTC No. Index ("SELF-DIAG [CURRENT]"), ("SELF-DIAG [PAST]" or "TROUBLE DIAG RECORD")

DTC No.	Trouble diagnosis name	DTC detecting condition	Possible cause
B1058 B1059 B1060 B1061 B1062 B1063	CONTROL UNIT	Diagnosis sensor unit is out of order.	Internal breakdown in diagnosis sensor unit (ACU).

#### DTC CONFIRMATION PROCEDURE (With CONSULT-III)

##### 1.INSPECTION START

Turn ignition switch ON.

>> GO TO 2.

##### 2.CHECK SELF-DIAG RESULT

Check the screen of CONSULT-III.

Is malfunctioning part detected?

- YES >> Refer to [SRC-206. "Diagnosis Procedure"](#).
- NO >> **INSPECTION END.**

#### DTC CONFIRMATION PROCEDURE (Without CONSULT-III)

##### NOTE:

- SRS will not enter diagnosis mode if no malfunction is detected in user mode.

##### 1.INSPECTION START

Turn ignition switch ON.

A  
B  
C  
D  
E  
F  
G  
I  
J  
K  
L  
M  
N  
O  
P

SRC

# B1058, B1059, B1060, B1061, B1062, B1063 DIAGNOSIS SENSOR UNIT

[FOR MEXICO]

< DTC/CIRCUIT DIAGNOSIS >

---

>> GO TO 2.

## 2.CHECK AIR BAG WARNING LAMP

---

Check the warning lamp status.

Is malfunctioning part detected?

YES >> Refer to [SRC-303, "DTC Index"](#).

NO >> **INSPECTION END.**

## Diagnosis Procedure

INFOID:000000005252882

With CONSULT-III

### **WARNING:**

- **Before servicing, turn ignition switch OFF, disconnect both battery terminals and wait at least 3 minutes. (To discharge backup capacitor.)**
- **Do not use unspecified tester or other measuring device.**

## DIAGNOSTIC PROCEDURE

### 1.CHECK HARNESS CONNECTOR

---

Check the connection of harness connector.

Is the inspection result normal?

YES >> GO TO 2.

NO >> Repair or replace harness connectors.

### 2.CHECK WIRING HARNESS

---

Check the wiring harness externals.

Is the inspection result normal?

YES >> GO TO 3.

NO >> Replace wiring harness.

### 3.CHECK DIAGNOSIS SENSOR UNIT

---

1. Replace diagnosis sensor unit (ACU).

2. Check the screen of CONSULT-III.

Is the inspection result normal?

YES >> **INSPECTION END.**

NO >> Check the intermittent incident. Refer to [GI-40, "Intermittent Incident"](#).

B1065 ASSIST A/B MODULE

Description

INFOID:000000005252883

DTC B1065 [OPEN] ASSIST A/B MODULE

For front passenger air bag module, crash is judged by main "G" sensor output signal and sub "G" sensor in front direction.

OPERATION

In the case of a frontal collision whose acceleration exceeds the specified level, the ignition materials are ignited by electric ignition system. The system burns and introduces the chemical reaction of gas generating materials to generate hot gases that flow into the air bag through a filter and expand the bag.

STRUCTURE

Front passenger air bag module mainly consists of air bag and inflator which inflates air bag.

INSTALLATION

Front passenger air bag module is installed on the instrument panel with fixed bolts.

DTC Logic

INFOID:000000005252884

DTC DETECTION LOGIC

With CONSULT-III

DTC No. Index ("SELF-DIAG [CURRENT]"), ("SELF-DIAG [PAST]" or "TROUBLE DIAG RECORD")



DTC No.	Trouble diagnosis name	DTC detecting condition	Possible cause
B1065	ASSIST A/B MODULE [OPEN]	Front passenger air bag module circuit is open.	<ul style="list-style-type: none"> <li>Disconnection of wiring harness and open.</li> <li>Internal breakdown in front passenger air bag module.</li> <li>Internal breakdown in diagnosis sensor unit (ACU).</li> </ul>

DTC CONFIRMATION PROCEDURE (With CONSULT-III)

1.INSPECTION START

Turn ignition switch ON.

>> GO TO 2.

2.CHECK SELF-DIAG RESULT

Check the screen of CONSULT-III.

Is malfunctioning part detected?

- YES >> Refer to [SRC-208, "Diagnosis Procedure"](#).
- NO >> **INSPECTION END.**

DTC CONFIRMATION PROCEDURE (Without CONSULT-III)

NOTE:

- SRS will not enter diagnosis mode if no malfunction is detected in user mode.

1.INSPECTION START

Turn ignition switch ON.

>> GO TO 2.

< DTC/CIRCUIT DIAGNOSIS >

---

## 2.CHECK AIR BAG WARNING LAMP

---

Check the warning lamp status.

Is malfunctioning part detected?

- YES >> Refer to [SRC-303, "DTC Index"](#).  
NO >> **INSPECTION END.**

### Diagnosis Procedure

INFOID:000000005252885

With CONSULT-III

#### **WARNING:**

- Before servicing, turn ignition switch OFF, disconnect both battery terminals and wait at least 3 minutes. (To discharge backup capacitor.)
- Do not use unspecified tester or other measuring device.

### DIAGNOSTIC PROCEDURE

---

## 1.CHECK HARNESS CONNECTOR

---

Check the connection of harness connector.

Is the inspection result normal?

- YES >> GO TO 2.  
NO >> Repair or replace harness connector.

---

## 2.CHECK WIRING HARNESS

---

Check the wiring harness externals.

Is the inspection result normal?

- YES >> GO TO 3.  
NO >> Repair or replace wiring harness.

---

## 3.CHECK FRONT PASSENGER AIR BAG MODULE

---

1. Replace front passenger air bag module.
2. Check the screen of CONSULT-III.

Is the inspection result normal?

- YES >> **INSPECTION END.**  
NO >> Check the intermittent incident. Refer to [GI-40, "Intermittent Incident"](#).



**B1066 ASSIST A/B MODULE**

**Description**

INFOID:000000005252886

**DTC B1066 [VB-SHORT] ASSIST A/B MODULE**

For front passenger air bag module, crash is judged by main “G” sensor output signal and sub “G” sensor in front direction.

**OPERATION**

In the case of a frontal collision whose acceleration exceeds the specified level, the ignition materials are ignited by electric ignition system. The system burns and introduces the chemical reaction of gas generating materials to generate hot gases that flow into the air bag through a filter and expand the bag.

**STRUCTURE**

Front passenger air bag module mainly consists of air bag and inflator which inflates air bag.

**INSTALLATION**

Front passenger air bag module is installed on the instrument panel with fixed bolts.

**DTC Logic**

INFOID:000000005252887

**DTC DETECTION LOGIC**

With CONSULT-III

DTC No. Index (“SELF-DIAG [CURRENT]”), (“SELF-DIAG [PAST]” or “TROUBLE DIAG RECORD”)

**SRC**

DTC No.	Trouble diagnosis name	DTC detecting condition	Possible cause
B1066	ASSIST A/B MODULE [VB-SHORT]	Front passenger air bag module circuit is shorted to some power supply circuit.	<ul style="list-style-type: none"> <li>• Disconnection of wiring harness and short.</li> <li>• Internal breakdown in front passenger air bag module.</li> <li>• Internal breakdown in diagnosis sensor unit (ACU).</li> </ul>

**DTC CONFIRMATION PROCEDURE (With CONSULT-III)**

**1.INSPECTION START**

Turn ignition switch ON.

>> GO TO 2.

**2.CHECK SELF-DIAG RESULT**

Check the screen of CONSULT-III.

Is malfunctioning part detected?

- YES >> Refer to [SRC-210, "Diagnosis Procedure"](#).
- NO >> **INSPECTION END.**

**DTC CONFIRMATION PROCEDURE (Without CONSULT-III)**

**NOTE:**

- SRS will not enter diagnosis mode if no malfunction is detected in user mode.

**1.INSPECTION START**

Turn ignition switch ON.

>> GO TO 2.

< DTC/CIRCUIT DIAGNOSIS >

---

## 2.CHECK AIR BAG WARNING LAMP

---

Check the warning lamp status.

Is malfunctioning part detected?

- YES >> Refer to [SRC-303, "DTC Index"](#).  
NO >> **INSPECTION END.**

### Diagnosis Procedure

INFOID:000000005252888

With CONSULT-III

#### **WARNING:**

- Before servicing, turn ignition switch OFF, disconnect both battery terminals and wait at least 3 minutes. (To discharge backup capacitor.)
- Do not use unspecified tester or other measuring device.

### DIAGNOSTIC PROCEDURE

---

## 1.CHECK HARNESS CONNECTOR

---

Check the connection of harness connector.

Is the inspection result normal?

- YES >> GO TO 2.  
NO >> Repair or replace harness connector.

---

## 2.CHECK WIRING HARNESS

---

Check the wiring harness externals.

Is the inspection result normal?

- YES >> GO TO 3.  
NO >> Repair or replace wiring harness.

---

## 3.CHECK FRONT PASSENGER AIR BAG MODULE

---

1. Replace front passenger air bag module.
2. Check the screen of CONSULT-III.

Is the inspection result normal?

- YES >> **INSPECTION END.**  
NO >> Check the intermittent incident. Refer to [GI-40, "Intermittent Incident"](#).

**B1067 ASSIST A/B MODULE**

**Description**

INFOID:000000005252889

**DTC B1067 [GND-SHORT] ASSIST A/B MODULE**

For front passenger air bag module, crash is judged by main “G” sensor output signal and sub “G” sensor in front direction.

**OPERATION**

In the case of a frontal collision whose acceleration exceeds the specified level, the ignition materials are ignited by electric ignition system. The system burns and introduces the chemical reaction of gas generating materials to generate hot gases that flow into the air bag through a filter and expand the bag.

**STRUCTURE**

Front passenger air bag module mainly consists of air bag and inflator which inflates air bag.

**INSTALLATION**

Front passenger air bag module is installed on the instrument panel with fixed bolts.

**DTC Logic**

INFOID:000000005252890

**DTC DETECTION LOGIC**

With CONSULT-III

DTC No. Index (“SELF-DIAG [CURRENT]”), (“SELF-DIAG [PAST]” or “TROUBLE DIAG RECORD”)

**SRC**

DTC No.	Trouble diagnosis name	DTC detecting condition	Possible cause
B1067	ASSIST A/B MODULE [GND-SHORT]	Front passenger air bag module circuit is shorted to ground.	<ul style="list-style-type: none"> <li>• Disconnection of wiring harness and short.</li> <li>• Internal breakdown in front passenger air bag module.</li> <li>• Internal breakdown in diagnosis sensor unit (ACU).</li> </ul>

**DTC CONFIRMATION PROCEDURE (With CONSULT-III)**

**1.INSPECTION START**

Turn ignition switch ON.

>> GO TO 2.

**2.CHECK SELF-DIAG RESULT**

Check the screen of CONSULT-III.

Is malfunctioning part detected?

- YES >> Refer to [SRC-212, "Diagnosis Procedure"](#).
- NO >> **INSPECTION END.**

**DTC CONFIRMATION PROCEDURE (Without CONSULT-III)**

**NOTE:**

- SRS will not enter diagnosis mode if no malfunction is detected in user mode.

**1.INSPECTION START**

Turn ignition switch ON.

>> GO TO 2.

< DTC/CIRCUIT DIAGNOSIS >

---

## 2.CHECK AIR BAG WARNING LAMP

---

Check the warning lamp status.

Is malfunctioning part detected?

- YES >> Refer to [SRC-303, "DTC Index"](#).  
NO >> **INSPECTION END.**

### Diagnosis Procedure

INFOID:000000005252891

With CONSULT-III

#### **WARNING:**

- **Before servicing, turn ignition switch OFF, disconnect both battery terminals and wait at least 3 minutes. (To discharge backup capacitor.)**
- **Do not use unspecified tester or other measuring device.**

### DIAGNOSTIC PROCEDURE

---

## 1.CHECK HARNESS CONNECTOR

---

Check the connection of harness connector.

Is the inspection result normal?

- YES >> GO TO 2.  
NO >> Repair or replace harness connector.

---

## 2.CHECK WIRING HARNESS

---

Check the wiring harness externals.

Is the inspection result normal?

- YES >> GO TO 3.  
NO >> Replace wiring harness.

---

## 3.CHECK FRONT PASSENGER AIR BAG MODULE

---

1. Replace front passenger air bag module.
2. Check the screen of CONSULT-III.

Is the inspection result normal?

- YES >> **INSPECTION END.**  
NO >> Check the intermittent incident. Refer to [GI-40, "Intermittent Incident"](#).

**B1068 ASSIST A/B MODULE**

**Description**

INFOID:000000005252892

**DTC B1068 [SHORT] ASSIST A/B MODULE**

For front passenger air bag module, crash is judged by main “G” sensor output signal and sub “G” sensor in front direction.

**OPERATION**

In the case of a frontal collision whose acceleration exceeds the specified level, the ignition materials are ignited by electric ignition system. The system burns and introduces the chemical reaction of gas generating materials to generate hot gases that flow into the air bag through a filter and expand the bag.

**STRUCTURE**

Front passenger air bag module mainly consists of air bag and inflator which inflates air bag.

**INSTALLATION**

Front passenger air bag module is installed on the instrument panel with fixed bolts.

**DTC Logic**

INFOID:000000005252893

**DTC DETECTION LOGIC**

With CONSULT-III

DTC No. Index (“SELF-DIAG [CURRENT]”), (“SELF-DIAG [PAST]” or “TROUBLE DIAG RECORD”)

**SRC**

DTC No.	Trouble diagnosis name	DTC detecting condition	Possible cause
B1068	ASSIST A/B MODULE [SHORT]	Front passenger air bag module circuits are shorted to each other.	<ul style="list-style-type: none"> <li>• Disconnection of wiring harness and short.</li> <li>• Internal breakdown in front passenger air bag module.</li> <li>• Internal breakdown in diagnosis sensor unit (ACU).</li> </ul>

**DTC CONFIRMATION PROCEDURE (With CONSULT-III)**

**1.INSPECTION START**

Turn ignition switch ON.

>> GO TO 2.

**2.CHECK SELF-DIAG RESULT**

Check the screen of CONSULT-III.

Is malfunctioning part detected?

- YES >> Refer to [SRC-214, "Diagnosis Procedure"](#).
- NO >> **INSPECTION END.**

**DTC CONFIRMATION PROCEDURE (Without CONSULT-III)**

**NOTE:**

- SRS will not enter diagnosis mode if no malfunction is detected in user mode.

**1.INSPECTION START**

Turn ignition switch ON.

>> GO TO 2.

< DTC/CIRCUIT DIAGNOSIS >

---

## 2.CHECK AIR BAG WARNING LAMP

---

Check the warning lamp status.

Is malfunctioning part detected?

- YES >> Refer to [SRC-303, "DTC Index"](#).
- NO >> **INSPECTION END.**

### Diagnosis Procedure

INFOID:000000005252894

With CONSULT-III

#### **WARNING:**

- Before servicing, turn ignition switch OFF, disconnect both battery terminal and wait at least 3 minutes. (To discharge backup capacitor.)
- Do not use unspecified tester or other measuring device.

### DIAGNOSTIC PROCEDURE

---

## 1.CHECK HARNESS CONNECTOR

---

Check the connection of harness connector.

Is the inspection result normal?

- YES >> GO TO 2.
- NO >> Repair or replace harness connector.

---

## 2.CHECK WIRING HARNESS

---

Check the wiring harness externals.

Is the inspection result normal?

- YES >> GO TO 3.
- NO >> Repair or replace wiring harness.

---

## 3.CHECK FRONT PASSENGER AIR BAG MODULE

---

1. Replace front passenger air bag module.
2. Check the screen of CONSULT-III.

Is the inspection result normal?

- YES >> **INSPECTION END.**
- NO >> Check the intermittent incident. Refer to [GI-40, "Intermittent Incident"](#).

# B1074, B1075, B1076, B1077, B1078, B1079 DIAGNOSIS SENSOR UNIT

< DTC/CIRCUIT DIAGNOSIS >

[FOR MEXICO]

## B1074, B1075, B1076, B1077, B1078, B1079 DIAGNOSIS SENSOR UNIT

### Description

INFOID:000000005252895

#### DTC B1074, B1075, B1076, B1077, B1078, B1079 DIAGNOSIS SENSOR UNIT

Detects the whole SRS electrical system and displays the malfunction either by illuminating or blinking the air bag warning lamp in the combination meter. Malfunctioning part can be detected by on board self-diagnosis system and electro-diagnosis tester CONSULT-III.

### OPERATION

It detects a shock that exceeds specified level and monitors such systems as the driver and passenger air bag, side air bag, curtain air bag, pre-tensioner seat belts operate properly.

### STRUCTURE

It contains the "G" sensors for both frontal and side collisions and spare battery function in case of main battery damage in collision.

### INSTALLATION

SRS diagnosis sensor unit is installed under the center console with fixed bolts.

### DTC Logic

INFOID:000000005252896

#### DTC DETECTION LOGIC

With CONSULT-III

DTC No. Index ("SELF-DIAG [CURRENT]"), ("SELF-DIAG [PAST]" or "TROUBLE DIAG RECORD")

DTC No.	Trouble diagnosis name	DTC detecting condition	Possible cause
B1074 B1075 B1076 B1077 B1078 B1079	CONTROL UNIT	Diagnosis sensor unit is out of order.	Internal breakdown in diagnosis sensor unit (ACU).

#### DTC CONFIRMATION PROCEDURE (With CONSULT-III)

##### 1.INSPECTION START

Turn ignition switch ON.

>> GO TO 2.

##### 2.CHECK SELF-DIAG RESULT

Check the screen of CONSULT-III.

Is malfunctioning part detected?

- YES >> Refer to [SRC-216. "Diagnosis Procedure"](#).
- NO >> **INSPECTION END.**

#### DTC CONFIRMATION PROCEDURE (Without CONSULT-III)

##### NOTE:

- SRS will not enter diagnosis mode if no malfunction is detected in user mode.

##### 1.INSPECTION START

Turn ignition switch ON.

A  
B  
C  
D  
E  
F  
G  
I  
J  
K  
L  
M  
N  
O  
P

SRC

# B1074, B1075, B1076, B1077, B1078, B1079 DIAGNOSIS SENSOR UNIT

< DTC/CIRCUIT DIAGNOSIS >

[FOR MEXICO]

>> GO TO 2.

## 2.CHECK AIR BAG WARNING LAMP

Check the warning lamp status.

Is malfunctioning part detected?

YES >> Refer to [SRC-303, "DTC Index"](#).

NO >> **INSPECTION END.**

## Diagnosis Procedure

INFOID:000000005252897

With CONSULT-III

### **WARNING:**

- **Before servicing, turn ignition switch OFF, disconnect both battery terminals and wait at least 3 minutes. (To discharge backup capacitor.)**
- **Do not use unspecified tester or other measuring device.**

## DIAGNOSTIC PROCEDURE

### 1.CHECK HARNESS CONNECTOR

Check the connection of harness connector.

Is the inspection result normal?

YES >> GO TO 2.

NO >> Repair or replace harness connectors.

### 2.CHECK WIRING HARNESS

Check the wiring harness externals.

Is the inspection result normal?

YES >> GO TO 3.

NO >> Repair or replace wiring harness.

### 3.CHECK DIAGNOSIS SENSOR UNIT

1. Replace diagnosis sensor unit (ACU).

2. Check the screen of CONSULT-III.

Is the inspection result normal?

YES >> **INSPECTION END.**

NO >> Check the intermittent incident. Refer to [GI-40, "Intermittent Incident"](#).



# B1081 PRE-TEN FRONT RH

< DTC/CIRCUIT DIAGNOSIS >

[FOR MEXICO]

## B1081 PRE-TEN FRONT RH

### Description

INFOID:000000005252898

### DTC B1081 [OPEN] PRE-TEN FRONT RH

For front RH seat belt pre-tensioner, crash is judged by main "G" sensor output signal and sub "G" sensor in front direction.

### OPERATION

In the case of a frontal collision that exceeds specified impact level, the diagnosis sensor unit detects the deceleration caused by collision. If restrains the passenger with seat belt easing the stress on passengers chest with load limiter.

### STRUCTURE

The restraint system for front seat occupant consists of the pre-tensioner mechanism and load limiter mechanism.

### INSTALLATION

Front RH seat belt pre-tensioner is installed on the underside of center pillar with fixed nuts.

### DTC Logic

INFOID:000000005252899

### DTC DETECTION LOGIC

With CONSULT-III

DTC No. Index ("SELF-DIAG [CURRENT]"), ("SELF-DIAG [PAST]" or "TROUBLE DIAG RECORD")

DTC No.	Trouble diagnosis name	DTC detecting condition	Possible cause
B1081	PRE-TEN FRONT RH [OPEN]	Front RH seat belt pre-tensioner circuit is open.	<ul style="list-style-type: none"><li>• Disconnection of wiring harness and open.</li><li>• Internal breakdown in front RH seat belt pre-tensioner.</li><li>• Internal breakdown in diagnosis sensor unit (ACU).</li></ul>

### DTC CONFIRMATION PROCEDURE (With CONSULT-III)

#### 1.INSPECTION START

Turn ignition switch ON.

>> GO TO 2.

#### 2.CHECK SELF-DIAG RESULT

Check the screen of CONSULT-III.

Is malfunctioning part detected?

YES >> Refer to [SRC-218. "Diagnosis Procedure"](#).

NO >> **INSPECTION END.**

### DTC CONFIRMATION PROCEDURE (Without CONSULT-III)

#### NOTE:

- SRS will not enter diagnosis mode if no malfunction is detected in user mode.

#### 1.INSPECTION START

Turn ignition switch ON.

A

B

C

D

E

F

G

SRC

I

J

K

L

M

N

O

P

&lt; DTC/CIRCUIT DIAGNOSIS &gt;

&gt;&gt; GO TO 2.

**2.CHECK AIR BAG WARNING LAMP**

Check the warning lamp status.

Is malfunctioning part detected?YES >> Refer to [SRC-303, "DTC Index"](#).NO >> **INSPECTION END.**

## Diagnosis Procedure

INFOID:000000005252900

With CONSULT-III

**WARNING:**

- Before servicing, turn ignition switch OFF, disconnect both battery terminals and wait at least 3 minutes. (To discharge backup capacitor.)
- Do not use unspecified tester or other measuring device.

## DIAGNOSTIC PROCEDURE

**1.CHECK HARNESS CONNECTOR**

Check the connection of harness connector.

Is the inspection result normal?

YES &gt;&gt; GO TO 2.

NO &gt;&gt; Repair or replace harness connector.

**2.CHECK WIRING HARNESS**

Check the wiring harness externals.

Is the inspection result normal?

YES &gt;&gt; GO TO 3.

NO &gt;&gt; Repair or replace wiring harness.

**3.CHECK FRONT SEAT BELT PRE-TENSIONER**

1. Replace front RH seat belt pre-tensioner.

2. Check the screen of CONSULT-III.

Is the inspection result normal?YES >> **INSPECTION END.**NO >> Check the intermittent incident. Refer to [GI-40, "Intermittent Incident"](#).

**B1082 PRE-TEN FRONT RH**

**Description**

INFOID:000000005252901

**DTC B1082 [VB-SHORT] PRE-TEN FRONT RH**

For front RH seat belt pre-tensioner, crash is judged by main "G" sensor output signal and sub "G" sensor in front direction.

**OPERATION**

In the case of a frontal collision that exceeds specified impact level, the diagnosis sensor unit detects the deceleration caused by collision. If restrains the passenger with seat belt easing the stress on passengers chest with load limiter.

**STRUCTURE**

The restraint system for front seat occupant consists of the pre-tensioner mechanism and load limiter mechanism.

**INSTALLATION**

Front RH seat belt pre-tensioner is installed on the underside of center pillar with fixed nuts.

**DTC Logic**

INFOID:000000005252902

**DTC DETECTION LOGIC**

With CONSULT-III

DTC No. Index ("SELF-DIAG [CURRENT]"), ("SELF-DIAG [PAST]" or "TROUBLE DIAG RECORD")

**SRC**

DTC No.	Trouble diagnosis name	DTC detecting condition	Possible cause
B1082	PRE-TEN FRONT RH [VB-SHORT]	Front RH seat belt pre-tensioner circuit is shorted to some power supply circuit.	<ul style="list-style-type: none"> <li>• Disconnection of wiring harness and short.</li> <li>• Internal breakdown in front RH seat belt pre-tensioner.</li> <li>• Internal breakdown in diagnosis sensor unit (ACU).</li> </ul>

**DTC CONFIRMATION PROCEDURE (With CONSULT-III)**

**1.INSPECTION START**

Turn ignition switch ON.

>> GO TO 2.

**2.CHECK SELF-DIAG RESULT**

Check the screen of CONSULT-III.

Is malfunctioning part detected?

- YES >> Refer to [SRC-220. "Diagnosis Procedure"](#).
- NO >> **INSPECTION END.**

**DTC CONFIRMATION PROCEDURE (Without CONSULT-III)**

**NOTE:**

- SRS will not enter diagnosis mode if no malfunction is detected in user mode.

**1.INSPECTION START**

Turn ignition switch ON.

&lt; DTC/CIRCUIT DIAGNOSIS &gt;

&gt;&gt; GO TO 2.

**2.CHECK AIR BAG WARNING LAMP**

Check the warning lamp status.

Is malfunctioning part detected?YES >> Refer to [SRC-303, "DTC Index"](#).NO >> **INSPECTION END.**

## Diagnosis Procedure

INFOID:000000005252903

With CONSULT-III

**WARNING:**

- Before servicing, turn ignition switch OFF, disconnect both battery terminals and wait at least 3 minutes. (To discharge backup capacitor.)
- Do not use unspecified tester or other measuring device.

## DIAGNOSTIC PROCEDURE

**1.CHECK HARNESS CONNECTOR**

Check the connection of harness connector.

Is the inspection result normal?

YES &gt;&gt; GO TO 2.

NO &gt;&gt; Repair or replace harness connector.

**2.CHECK WIRING HARNESS**

Check the wiring harness externals.

Is the inspection result normal?

YES &gt;&gt; GO TO 3.

NO &gt;&gt; Repair or replace wiring harness.

**3.CHECK FRONT SEAT BELT PRE-TENSIONER**

1. Replace front RH seat belt pre-tensioner.

2. Check the screen of CONSULT-III.

Is the inspection result normal?YES >> **INSPECTION END.**NO >> Check the intermittent incident. Refer to [GI-40, "Intermittent Incident"](#).

**B1083 PRE-TEN FRONT RH**

**Description**

INFOID:000000005252904

**DTC B1083 [GND-SHORT] PRE-TEN FRONT RH**

For front RH seat belt pre-tensioner, crash is judged by main “G” sensor output signal and sub “G” sensor in front direction.

**OPERATION**

In case of frontal collision that exceeds specified impact level, the diagnosis sensor unit detects the deceleration caused by collision. If restrains the passenger with seat belt easing the stress on passengers chest with load limiter.

**STRUCTURE**

The restraint system for front seat occupant consists of the pre-tensioner mechanism and load limiter mechanism.

**INSTALLATION**

Front RH seat belt pre-tensioner is installed on the underside of center pillar with fixed nuts.

**DTC Logic**

INFOID:000000005252905

**DTC DETECTION LOGIC**

With CONSULT-III

DTC No. Index (“SELF-DIAG [CURRENT]”), (“SELF-DIAG [PAST]” or “TROUBLE DIAG RECORD”)

**SRC**

DTC No.	Trouble diagnosis name	DTC detecting condition	Possible cause
B1083	PRE-TEN FRONT RH [GND-SHORT]	Front RH seat belt pre-tensioner circuit is shorted to ground.	<ul style="list-style-type: none"> <li>• Disconnection of wiring harness and short.</li> <li>• Internal breakdown in front RH seat belt pre-tensioner.</li> <li>• Internal breakdown in diagnosis sensor unit (ACU).</li> </ul>

**DTC CONFIRMATION PROCEDURE (With CONSULT-III)**

**1.INSPECTION START**

Turn ignition switch ON.

>> GO TO 2.

**2.CHECK SELF-DIAG RESULT**

Check the screen of CONSULT-III.

Is malfunctioning part detected?

YES >> Refer to [SRC-222. "Diagnosis Procedure"](#).

NO >> **INSPECTION END.**

**DTC CONFIRMATION PROCEDURE (Without CONSULT-III)**

**NOTE:**

- SRS will not enter diagnosis mode if no malfunction is detected in user mode.

**1.INSPECTION START**

Turn ignition switch ON.

&lt; DTC/CIRCUIT DIAGNOSIS &gt;

&gt;&gt; GO TO 2.

**2.CHECK AIR BAG WARNING LAMP**

Check the warning lamp status.

Is malfunctioning part detected?YES >> Refer to [SRC-303, "DTC Index"](#).NO >> **INSPECTION END.**

## Diagnosis Procedure

INFOID:000000005252906

With CONSULT-III

**WARNING:**

- Before servicing, turn ignition switch OFF, disconnect both battery terminals and wait at least 3 minutes. (To discharge backup capacitor.)
- Do not use unspecified tester or other measuring device.

## DIAGNOSTIC PROCEDURE

**1.CHECK HARNESS CONNECTOR**

Check the connection of harness connector.

Is the inspection result normal?

YES &gt;&gt; GO TO 2.

NO &gt;&gt; Repair or replace harness connector.

**2.CHECK WIRING HARNESS**

Check the wiring harness externals.

Is the inspection result normal?

YES &gt;&gt; GO TO 3.

NO &gt;&gt; Repair or replace wiring harness.

**3.CHECK FRONT SEAT BELT PRE-TENSIONER**

1. Replace front RH seat belt pre-tensioner.

2. Check the screen of CONSULT-III.

Is the inspection result normal?YES >> **INSPECTION END.**NO >> Check the intermittent incident. Refer to [GI-40, "Intermittent Incident"](#).

# B1084 PRE-TEN FRONT RH

< DTC/CIRCUIT DIAGNOSIS >

[FOR MEXICO]

## B1084 PRE-TEN FRONT RH

### Description

INFOID:000000005252907

#### DTC B1084 [SHORT] PRE-TEN FRONT RH

For front RH seat belt pre-tensioner, crash is judged by main “G” sensor output signal and sub “G” sensor in front direction.

#### OPERATION

In the case of a frontal collision that exceeds specified impact level, the diagnosis sensor unit detects the deceleration caused by collision. If restrains the passenger with seat belt easing the stress on passengers chest with load limiter.

#### STRUCTURE

The restraint system for front seat occupant consists of the pre-tensioner mechanism and load limiter mechanism.

#### INSTALLATION

Front RH seat belt pre-tensioner is installed on the underside of center pillar with fixed nuts.

### DTC Logic

INFOID:000000005252908

#### DTC DETECTION LOGIC

With CONSULT-III

DTC No. Index (“SELF-DIAG [CURRENT]”), (“SELF-DIAG [PAST]” or “TROUBLE DIAG RECORD”)

DTC No.	Trouble diagnosis name	DTC detecting condition	Possible cause
B1084	PRE-TEN FRONT RH [SHORT]	Front RH seat belt pre-tensioner circuit are shorted to each other.	<ul style="list-style-type: none"><li>• Disconnection of wiring harness and short.</li><li>• Internal breakdown in front RH seat belt pre-tensioner.</li><li>• Internal breakdown in diagnosis sensor unit (ACU).</li></ul>

#### DTC CONFIRMATION PROCEDURE (With CONSULT-III)

##### 1.INSPECTION START

Turn ignition switch ON.

>> GO TO 2.

##### 2.CHECK SELF-DIAG RESULT

Check the screen of CONSULT-III.

Is malfunctioning part detected?

YES >> Refer to [SRC-224. "Diagnosis Procedure"](#).

NO >> **INSPECTION END.**

#### DTC CONFIRMATION PROCEDURE (Without CONSULT-III)

##### NOTE:

- SRS will not enter diagnosis mode if no malfunction is detected in user mode.

##### 1.INSPECTION START

Turn ignition switch ON.

A  
B  
C  
D  
E  
F  
G  
I  
J  
K  
L  
M  
N  
O  
P

SRC

&lt; DTC/CIRCUIT DIAGNOSIS &gt;

&gt;&gt; GO TO 2.

**2.CHECK AIR BAG WARNING LAMP**

Check the warning lamp status.

Is malfunctioning part detected?YES >> Refer to [SRC-303, "DTC Index"](#).NO >> **INSPECTION END.**

## Diagnosis Procedure

INFOID:000000005252909

With CONSULT-III

**WARNING:**

- Before servicing, turn ignition switch OFF, disconnect both battery terminals and wait at least 3 minutes. (To discharge backup capacitor.)
- Do not use unspecified tester or other measuring device.

## DIAGNOSTIC PROCEDURE

**1.CHECK HARNESS CONNECTOR**

Check the connection of harness connector.

Is the inspection result normal?

YES &gt;&gt; GO TO 2.

NO &gt;&gt; Repair or replace harness connector.

**2.CHECK WIRING HARNESS**

Check the wiring harness externals.

Is the inspection result normal?

YES &gt;&gt; GO TO 3.

NO &gt;&gt; Repair or replace wiring harness.

**3.CHECK FRONT SEAT BELT PRE-TENSIONER**

1. Replace front RH seat belt pre-tensioner.

2. Check the screen of CONSULT-III.

Is the inspection result normal?YES >> **INSPECTION END.**NO >> Check the intermittent incident. Refer to [GI-40, "Intermittent Incident"](#).



# B1086 PRE-TEN FRONT LH

< DTC/CIRCUIT DIAGNOSIS >

[FOR MEXICO]

## B1086 PRE-TEN FRONT LH

### Description

INFOID:000000005252910

### DTC B1086 [OPEN] PRE-TEN FRONT LH

For front LH seat belt pre-tensioner, crash is judged by main "G" sensor output signal and sub "G" sensor in front direction.

### OPERATION

In the case of a frontal collision that exceeds specified impact level, the diagnosis sensor unit detects the deceleration caused by collision. If restrains the passenger with seat belt easing the stress on passengers chest with load limiter.

### STRUCTURE

The restraint system for front seat occupant consists of the pre-tensioner mechanism and load limiter mechanism.

### INSTALLATION

Front LH seat belt pre-tensioner is installed on the underside of center pillar with fixed nuts.

### DTC Logic

INFOID:000000005252911

### DTC DETECTION LOGIC

With CONSULT-III

DTC No. Index ("SELF-DIAG [CURRENT]"), ("SELF-DIAG [PAST]" or "TROUBLE DIAG RECORD")

DTC No.	Trouble diagnosis name	DTC detecting condition	Possible cause
B1086	PRE-TEN FRONT LH [OPEN]	Front LH seat belt pre-tensioner circuit is open.	<ul style="list-style-type: none"> <li>Disconnection of wiring harness and open.</li> <li>Internal breakdown in front LH seat belt pre-tensioner.</li> <li>Internal breakdown in diagnosis sensor unit (ACU).</li> </ul>

### DTC CONFIRMATION PROCEDURE (With CONSULT-III)

#### 1.INSPECTION START

Turn ignition switch ON.

>> GO TO 2.

#### 2.CHECK SELF-DIAG RESULT

Check the screen of CONSULT-III.

Is malfunctioning part detected?

- YES >> Refer to [SRC-226. "Diagnosis Procedure"](#).
- NO >> **INSPECTION END.**

### DTC CONFIRMATION PROCEDURE (Without CONSULT-III)

#### NOTE:

- SRS will not enter diagnosis mode if no malfunction is detected in user mode.

#### 1.INSPECTION START

Turn ignition switch ON.

A  
B  
C  
D  
E  
F  
G  
I  
J  
K  
L  
M  
N  
O  
P

SRC

< DTC/CIRCUIT DIAGNOSIS >

---

>> GO TO 2.

## 2.CHECK AIR BAG WARNING LAMP

---

Check the warning lamp status.

Is malfunctioning part detected?

YES >> Refer to [SRC-303, "DTC Index"](#).

NO >> **INSPECTION END.**

## Diagnosis Procedure

INFOID:000000005252912

With CONSULT-III

### **WARNING:**

- **Before servicing, turn ignition switch OFF, disconnect both battery terminals and wait at least 3 minutes. (To discharge backup capacitor.)**
- **Do not use unspecified tester or other measuring device.**

## DIAGNOSTIC PROCEDURE

### 1.CHECK HARNESS CONNECTOR

---

Check the connection of harness connector.

Is the inspection result normal?

YES >> GO TO 2.

NO >> Repair or replace harness connector.

### 2.CHECK WIRING HARNESS

---

Check the wiring harness externals.

Is the inspection result normal?

YES >> GO TO 3.

NO >> Replace wiring harness.

### 3.CHECK FRONT SEAT BELT PRE-TENSIONER

---

1. Replace front LH seat belt pre-tensioner.

2. Check the screen of CONSULT-III.

Is the inspection result normal?

YES >> **INSPECTION END.**

NO >> Check the intermittent incident. Refer to [GI-40, "Intermittent Incident"](#).

# B1087 PRE-TEN FRONT LH

< DTC/CIRCUIT DIAGNOSIS >

[FOR MEXICO]

## B1087 PRE-TEN FRONT LH

### Description

INFOID:000000005252913

### DTC B1087 [VB-SHORT] PRE-TEN FRONT LH

For front LH seat belt pre-tensioner, crash is judged by main "G" sensor output signal and sub "G" sensor in front direction.

### OPERATION

In the case of a frontal collision that exceeds specified impact level, the diagnosis sensor unit detects the deceleration caused by collision. If restrains the passenger with seat belt easing the stress on passengers chest with load limiter.

### STRUCTURE

The restraint system for front seat occupant consists of the pre-tensioner mechanism and load limiter mechanism.

### INSTALLATION

Front LH seat belt pre-tensioner is installed on the underside of center pillar with fixed nuts.

### DTC Logic

INFOID:000000005252914

### DTC DETECTION LOGIC

With CONSULT-III

DTC No. Index ("SELF-DIAG [CURRENT]"), ("SELF-DIAG [PAST]" or "TROUBLE DIAG RECORD")

DTC No.	Trouble diagnosis name	DTC detecting condition	Possible cause
B1087	PRE-TEN FRONT LH [VB-SHORT]	Front LH seat belt pre-tensioner circuit is shorted to some power supply circuit.	<ul style="list-style-type: none"> <li>Disconnection of wiring harness and short.</li> <li>Internal breakdown in front LH seat belt pre-tensioner.</li> <li>Internal breakdown in diagnosis sensor unit (ACU).</li> </ul>

### DTC CONFIRMATION PROCEDURE (With CONSULT-III)

#### 1.INSPECTION START

Turn ignition switch ON.

>> GO TO 2.

#### 2.CHECK SELF-DIAG RESULT

Check the screen of CONSULT-III.

Is malfunctioning part detected?

- YES >> Refer to [SRC-228. "Diagnosis Procedure"](#).
- NO >> **INSPECTION END.**

### DTC CONFIRMATION PROCEDURE (Without CONSULT-III)

#### NOTE:

- SRS will not enter diagnosis mode if no malfunction is detected in user mode.

#### 1.INSPECTION START

Turn ignition switch ON.

A  
B  
C  
D  
E  
F  
G  
I  
J  
K  
L  
M  
N  
O  
P

SRC

< DTC/CIRCUIT DIAGNOSIS >

---

>> GO TO 2.

## 2.CHECK AIR BAG WARNING LAMP

---

Check the warning lamp status.

Is malfunctioning part detected?

YES >> Refer to [SRC-303, "DTC Index"](#).

NO >> **INSPECTION END.**

## Diagnosis Procedure

INFOID:000000005252915

With CONSULT-III

### **WARNING:**

- **Before servicing, turn ignition switch OFF, disconnect both battery terminals and wait at least 3 minutes. (To discharge backup capacitor.)**
- **Do not use unspecified tester or other measuring device.**

## DIAGNOSTIC PROCEDURE

### 1.CHECK HARNESS CONNECTOR

---

Check the connection of harness connector.

Is the inspection result normal?

YES >> GO TO 2.

NO >> Repair or replace harness connector.

### 2.CHECK WIRING HARNESS

---

Check the wiring harness externals.

Is the inspection result normal?

YES >> GO TO 3.

NO >> Repair or replace wiring harness.

### 3.CHECK FRONT SEAT BELT PRE-TENSIONER

---

1. Replace front LH seat belt pre-tensioner.

2. Check the screen of CONSULT-III.

Is the inspection result normal?

YES >> **INSPECTION END.**

NO >> Check the intermittent incident. Refer to [GI-40, "Intermittent Incident"](#).

# B1088 PRE-TEN FRONT LH

< DTC/CIRCUIT DIAGNOSIS >

[FOR MEXICO]

## B1088 PRE-TEN FRONT LH

### Description

INFOID:000000005252916

### DTC B1088 [GND-SHORT] PRE-TEN FRONT LH

For front LH seat belt pre-tensioner, crash is judged by main "G" sensor output signal and sub "G" sensor in front direction.

### OPERATION

In the case of a frontal collision that exceeds specified impact level, the diagnosis sensor unit detects the deceleration caused by collision. If restrains the passenger with seat belt easing the stress on passengers chest with load limiter.

### STRUCTURE

The restraint system for front seat occupant consists of the pre-tensioner mechanism and load limiter mechanism.

### INSTALLATION

Front LH seat belt pre-tensioner is installed on the underside of center pillar with fixed nuts.

### DTC Logic

INFOID:000000005252917

### DTC DETECTION LOGIC

With CONSULT-III

DTC No. Index ("SELF-DIAG [CURRENT]"), ("SELF-DIAG [PAST]" or "TROUBLE DIAG RECORD")

DTC No.	Trouble diagnosis name	DTC detecting condition	Possible cause
B1088	PRE-TEN FRONT LH [GND-SHORT]	Front LH seat belt pre-tensioner circuit is shorted to ground.	<ul style="list-style-type: none"> <li>Disconnection of wiring harness and short.</li> <li>Internal breakdown in front LH seat belt pre-tensioner.</li> <li>Internal breakdown in diagnosis sensor unit (ACU).</li> </ul>

### DTC CONFIRMATION PROCEDURE (With CONSULT-III)

#### 1.INSPECTION START

Turn ignition switch ON.

>> GO TO 2.

#### 2.CHECK SELF-DIAG RESULT

Check the screen of CONSULT-III.

Is malfunctioning part detected?

- YES >> Refer to [SRC-230. "Diagnosis Procedure"](#).
- NO >> **INSPECTION END.**

### DTC CONFIRMATION PROCEDURE (Without CONSULT-III)

#### NOTE:

- SRS will not enter diagnosis mode if no malfunction is detected in user mode.

#### 1.INSPECTION START

Turn ignition switch ON.

A  
B  
C  
D  
E  
F  
G  
I  
J  
K  
L  
M  
N  
O  
P

SRC

< DTC/CIRCUIT DIAGNOSIS >

---

>> GO TO 2.

## 2.CHECK AIR BAG WARNING LAMP

---

Check the warning lamp status.

Is malfunctioning part detected?

YES >> Refer to [SRC-303, "DTC Index"](#).

NO >> **INSPECTION END.**

## Diagnosis Procedure

INFOID:000000005252918

With CONSULT-III

### **WARNING:**

- **Before servicing, turn ignition switch OFF, disconnect both battery terminals and wait at least 3 minutes. (To discharge backup capacitor.)**
- **Do not use unspecified tester or other measuring device.**

## DIAGNOSTIC PROCEDURE

### 1.CHECK HARNESS CONNECTOR

---

Check the connection of harness connector.

Is the inspection result normal?

YES >> GO TO 2.

NO >> Repair or replace harness connector.

### 2.CHECK WIRING HARNESS

---

Check the wiring harness externals.

Is the inspection result normal?

YES >> GO TO 3.

NO >> Replace wiring harness.

### 3.CHECK FRONT SEAT BELT PRE-TENSIONER

---

1. Replace front LH seat belt pre-tensioner.

2. Check the screen of CONSULT-III.

Is the inspection result normal?

YES >> **INSPECTION END.**

NO >> Check the intermittent incident. Refer to [GI-40, "Intermittent Incident"](#).

# B1089 PRE-TEN FRONT LH

< DTC/CIRCUIT DIAGNOSIS >

[FOR MEXICO]

## B1089 PRE-TEN FRONT LH

### Description

INFOID:000000005252919

### DTC B1089 [SHORT] PRE-TEN FRONT LH

For front LH seat belt pre-tensioner, crash is judged by main "G" sensor output signal and sub "G" sensor in front direction.

### OPERATION

In the case of a frontal collision that exceeds specified impact level, the diagnosis sensor unit detects the deceleration caused by collision. If restrains the passenger with seat belt easing the stress on passengers chest with load limiter.

### STRUCTURE

The restraint system for front seat occupant consists of the pre-tensioner mechanism and load limiter mechanism.

### INSTALLATION

Front LH seat belt pre-tensioner is installed on the underside of center pillar with fixed nuts.

### DTC Logic

INFOID:000000005252920

### DTC DETECTION LOGIC

With CONSULT-III

DTC No. Index ("SELF-DIAG [CURRENT]"), ("SELF-DIAG [PAST]" or "TROUBLE DIAG RECORD")

DTC No.	Trouble diagnosis name	DTC detecting condition	Possible cause
B1089	PRE-TEN FRONT LH [SHORT]	Front LH seat belt pre-tensioner circuit are shorted to each other.	<ul style="list-style-type: none"><li>• Disconnection of wiring harness and short.</li><li>• Internal breakdown in front LH seat belt pre-tensioner.</li><li>• Internal breakdown in diagnosis sensor unit (ACU).</li></ul>

### DTC CONFIRMATION PROCEDURE (With CONSULT-III)

#### 1.INSPECTION START

Turn ignition switch ON.

>> GO TO 2.

#### 2.CHECK SELF-DIAG RESULT

Check the screen of CONSULT-III.

Is malfunctioning part detected?

- YES >> Refer to [SRC-232. "Diagnosis Procedure"](#).  
NO >> **INSPECTION END.**

### DTC CONFIRMATION PROCEDURE (Without CONSULT-III)

#### NOTE:

- SRS will not enter diagnosis mode if no malfunction is detected in user mode.

#### 1.INSPECTION START

Turn ignition switch ON.

A  
B  
C  
D  
E  
F  
G  
I  
J  
K  
L  
M  
N  
O  
P

SRC

< DTC/CIRCUIT DIAGNOSIS >

---

>> GO TO 2.

## 2.CHECK AIR BAG WARNING LAMP

---

Check the warning lamp status.

Is malfunctioning part detected?

YES >> Refer to [SRC-303, "DTC Index"](#).

NO >> **INSPECTION END.**

## Diagnosis Procedure

INFOID:000000005252921

With CONSULT-III

### **WARNING:**

- **Before servicing, turn ignition switch OFF, disconnect both battery terminals and wait at least 3 minutes. (To discharge backup capacitor.)**
- **Do not use unspecified tester or other measuring device.**

## DIAGNOSTIC PROCEDURE

### 1.CHECK HARNESS CONNECTOR

---

Check the connection of harness connector.

Is the inspection result normal?

YES >> GO TO 2.

NO >> Repair or replace harness connector.

### 2.CHECK WIRING HARNESS

---

Check the wiring harness externals.

Is the inspection result normal?

YES >> GO TO 3.

NO >> Replace wiring harness.

### 3.CHECK FRONT SEAT BELT PRE-TENSIONER

---

1. Replace front LH seat belt pre-tensioner.

2. Check the screen of CONSULT-III.

Is the inspection result normal?

YES >> **INSPECTION END.**

NO >> Check the intermittent incident. Refer to [GI-40, "Intermittent Incident"](#).



# B1106, B1107, B1108, B1109, B1110, B1111 DIAGNOSIS SENSOR UNIT

< DTC/CIRCUIT DIAGNOSIS >

[FOR MEXICO]

## B1106, B1107, B1108, B1109, B1110, B1111 DIAGNOSIS SENSOR UNIT

### Description

INFOID:000000005252922

### DTC B1106, B1107, B1108, B1109, B1110, B1111 DIAGNOSIS SENSOR UNIT

Detects the whole SRS electrical system and displays the malfunction either by illuminating or blinking the air bag warning lamp in the combination meter. Malfunctioning part can be detected by on board self-diagnosis system and electro-diagnosis tester CONSULT-III.

### OPERATION

It detects a shock that exceeds specified level and monitors such systems as the driver and passenger air bag, side air bag, curtain air bag, pre-tensioner seat belts operate properly.

### STRUCTURE

It contains the "G" sensors for both frontal and side collisions and spare battery function in case of main battery damage in collision.

### INSTALLATION

SRS diagnosis sensor unit is installed under the center console with fixed bolts.

### DTC Logic

INFOID:000000005252923

### DTC DETECTION LOGIC

With CONSULT-III

DTC No. Index ("SELF-DIAG [CURRENT]"), ("SELF-DIAG [PAST]" or "TROUBLE DIAG RECORD")

DTC No.	Trouble diagnosis name	DTC detecting condition	Possible cause
B1106 B1107 B1108 B1109 B1110 B1111	CONTROL UNIT	Diagnosis sensor unit is out of order.	Internal breakdown in diagnosis sensor unit (ACU).

### DTC CONFIRMATION PROCEDURE (With CONSULT-III)

#### 1.INSPECTION START

Turn ignition switch ON.

>> GO TO 2.

#### 2.CHECK SELF-DIAG RESULT

Check the screen of CONSULT-III.

Is malfunctioning part detected?

- YES >> Refer to [SRC-234. "Diagnosis Procedure"](#).
- NO >> **INSPECTION END.**

### DTC CONFIRMATION PROCEDURE (Without CONSULT-III)

#### NOTE:

- SRS will not enter diagnosis mode if no malfunction is detected in user mode.

#### 1.INSPECTION START

Turn ignition switch ON.

A  
B  
C  
D  
E  
F  
G  
I  
J  
K  
L  
M  
N  
O  
P

SRC

# B1106, B1107, B1108, B1109, B1110, B1111 DIAGNOSIS SENSOR UNIT

[FOR MEXICO]

< DTC/CIRCUIT DIAGNOSIS >

---

>> GO TO 2.

## 2.CHECK AIR BAG WARNING LAMP

---

Check the warning lamp status.

Is malfunctioning part detected?

YES >> Refer to [SRC-303, "DTC Index"](#).

NO >> **INSPECTION END.**

## Diagnosis Procedure

INFOID:000000005252924

With CONSULT-III

### **WARNING:**

- **Before servicing, turn ignition switch OFF, disconnect both battery terminals and wait at least 3 minutes. (To discharge backup capacitor.)**
- **Do not use unspecified tester or other measuring device.**

## DIAGNOSTIC PROCEDURE

### 1.CHECK HARNESS CONNECTOR

---

Check the connection of harness connector.

Is the inspection result normal?

YES >> GO TO 2.

NO >> Repair or replace harness connectors.

### 2.CHECK WIRING HARNESS

---

Check the wiring harness externals.

Is the inspection result normal?

YES >> GO TO 3.

NO >> Replace wiring harness.

### 3.CHECK DIAGNOSIS SENSOR UNIT

---

1. Replace diagnosis sensor unit (ACU).

2. Check the screen of CONSULT-III.

Is the inspection result normal?

YES >> **INSPECTION END.**

NO >> Check the intermittent incident. Refer to [GI-40, "Intermittent Incident"](#).

# B1113, B1114 SATELLITE SENS RH

< DTC/CIRCUIT DIAGNOSIS >

[FOR MEXICO]

## B1113, B1114 SATELLITE SENS RH

### Description

INFOID:000000005252925

### DTC B1113, B1114 [UNIT FAIL] SATELLITE SENS RH

Main "G" sensor generates signal voltage, when it detects deceleration beyond the specified level by vehicle side collision.

### OPERATION

When ACU define the both signal voltage of the "G" sensor and the Safing sensor to be that of collision which exceeds specified level, the driving circuit switches on and feeds the electric ignitor of both the side air bag and curtain air bag.

### STRUCTURE

Integrated type of the G sensor element for side collision with output terminals for signal voltage.

### INSTALLATION

RH satellite sensor is installed at the underside of center pillar with fixed nuts.

### DTC Logic

INFOID:000000005252926

### DTC DETECTION LOGIC

With CONSULT-III

DTC No. Index ("SELF-DIAG [CURRENT]"), ("SELF-DIAG [PAST]" or "TROUBLE DIAG RECORD")

DTC No.	Trouble diagnosis name	DTC detecting condition	Possible cause
B1113 B1114	SATELLITE SENS RH [UNIT FAIL]	RH satellite sensor is out of order.	<ul style="list-style-type: none"><li>• Disconnection of wiring harness.</li><li>• Internal breakdown in RH satellite sensor.</li><li>• Internal breakdown in diagnosis sensor unit (ACU).</li></ul>

### DTC CONFIRMATION PROCEDURE (With CONSULT-III)

#### 1.INSPECTION START

Turn ignition switch ON.

>> GO TO 2.

#### 2.CHECK SELF-DIAG RESULT

Check the screen of CONSULT-III.

Is malfunctioning part detected?

- YES >> Refer to [SRC-236, "Diagnosis Procedure"](#).
- NO >> **INSPECTION END.**

### DTC CONFIRMATION PROCEDURE (Without CONSULT-III)

#### NOTE:

- SRS will not enter diagnosis mode if no malfunction is detected in user mode.

#### 1.INSPECTION START

Turn ignition switch ON.

>> GO TO 2.

A  
B  
C  
D  
E  
F  
G  
I  
J  
K  
L  
M  
N  
O  
P

SRC

< DTC/CIRCUIT DIAGNOSIS >

---

## 2.CHECK AIR BAG WARNING LAMP

---

Check the warning lamp status.

Is malfunctioning part detected?

- YES >> Refer to [SRC-303, "DTC Index"](#).
- NO >> **INSPECTION END.**

### Diagnosis Procedure

INFOID:000000005252927

With CONSULT-III

#### **WARNING:**

- **Before servicing, turn ignition switch OFF, disconnect both battery terminals and wait at least 3 minutes. (To discharge backup capacitor.)**
- **Do not use unspecified tester or other measuring device.**

### DIAGNOSTIC PROCEDURE

---

#### 1.CHECK HARNESS CONNECTOR

---

Check the connection of harness connector.

Is the inspection result normal?

- YES >> GO TO 2.
- NO >> Repair or replace harness connector.

---

#### 2.CHECK WIRING HARNESS

---

Check the wiring harness externals.

Is the inspection result normal?

- YES >> GO TO 3.
- NO >> Repair or replace wiring harness.

---

#### 3.CHECK SATELLITE SENSOR

---

1. Replace RH satellite sensor.
2. Check the screen of CONSULT-III.

Is the inspection result normal?

- YES >> **INSPECTION END.**
- NO >> Check the intermittent incident. Refer to [GI-40, "Intermittent Incident"](#).

# B1115, B1116 SATELLITE SENS RH

< DTC/CIRCUIT DIAGNOSIS >

[FOR MEXICO]

## B1115, B1116 SATELLITE SENS RH

### Description

INFOID:000000005252928

### DTC B1115, B1116 [COMM FAIL] SATELLITE SENS RH

Main "G" sensor generates signal voltage, when it detects deceleration beyond the specified level by vehicle side collision.

### OPERATION

When ACU defines both signal voltage of the "G" sensor and the Safing sensor to be that of collision which exceeds specified level, the driving circuit switches on and feeds the electric ignitor of both the side air bag and curtain air bag.

### STRUCTURE

Integrated type of the G sensor element for side collision with output terminals for signal voltage.

### INSTALLATION

RH satellite sensor is installed at the underside of center pillar with fixed nuts.

### DTC Logic

INFOID:000000005252929

### DTC DETECTION LOGIC

With CONSULT-III

DTC No. Index ("SELF-DIAG [CURRENT]"), ("SELF-DIAG [PAST]" or "TROUBLE DIAG RECORD")

DTC No.	Trouble diagnosis name	DTC detecting condition	Possible cause
B1115 B1116	SATELLITE SENS RH [COMM FAIL] [UNMATCH]	RH satellite sensor is out of order.	<ul style="list-style-type: none"><li>• Disconnection of wiring harness.</li><li>• Internal breakdown in RH satellite sensor.</li><li>• Internal breakdown in diagnosis sensor unit (ACU).</li></ul>

### DTC CONFIRMATION PROCEDURE (With CONSULT-III)

#### 1.INSPECTION START

Turn ignition switch ON.

>> GO TO 2.

#### 2.CHECK SELF-DIAG RESULT

Check the screen of CONSULT-III.

Is malfunctioning part detected?

- YES >> Refer to [SRC-238, "Diagnosis Procedure"](#).  
NO >> **INSPECTION END.**

### DTC CONFIRMATION PROCEDURE (Without CONSULT-III)

#### NOTE:

- SRS will not enter diagnosis mode if no malfunction is detected in user mode.

#### 1.INSPECTION START

Turn ignition switch ON.

>> GO TO 2.

< DTC/CIRCUIT DIAGNOSIS >

---

## 2.CHECK AIR BAG WARNING LAMP

---

Check the warning lamp status.

Is malfunctioning part detected?

- YES >> Refer to [SRC-303, "DTC Index"](#).  
NO >> **INSPECTION END.**

### Diagnosis Procedure

INFOID:000000005252930

With CONSULT-III

#### **WARNING:**

- **Before servicing, turn ignition switch OFF, disconnect both battery terminals and wait at least 3 minutes. (To discharge backup capacitor.)**
- **Do not use unspecified tester or other measuring device.**

### DIAGNOSTIC PROCEDURE

---

#### 1.CHECK HARNESS CONNECTOR

---

Check the connection of harness connector.

Is the inspection result normal?

- YES >> GO TO 2.  
NO >> Repair or replace harness connector.

---

#### 2.CHECK WIRING HARNESS

---

Check the wiring harness externals.

Is the inspection result normal?

- YES >> GO TO 3.  
NO >> Repair or replace wiring harness.

---

#### 3.CHECK SATELLITE SENSOR

---

1. Replace RH satellite sensor.
2. Check the screen of CONSULT-III.

Is the inspection result normal?

- YES >> **INSPECTION END.**  
NO >> Check the intermittent incident. Refer to [GI-40, "Intermittent Incident"](#).

**B1118, B1119 SATELLITE SENS LH**

**Description**

INFOID:000000005252931

**DTC B1118, B1119 [UNIT FAIL] SATELLITE SENS LH**

Main “G” sensor generates signal voltage, when it detects deceleration beyond the specified level by vehicle side collision.

**OPERATION**

When ACU defines both signal voltage of the “G” sensor and the Safing sensor to be that of collision which exceeds specified level, the driving circuit switches on and feeds the electric ignitor of both the side air bag and curtain air bag.

**STRUCTURE**

Integrated type of the G sensor element for side collision with output terminals for signal voltage.

**INSTALLATION**

LH satellite sensor is installed at the underside of center pillar with fixed nuts.

**DTC Logic**

INFOID:000000005252932

**DTC DETECTION LOGIC**

With CONSULT-III

DTC No. Index (“SELF-DIAG [CURRENT]”), (“SELF-DIAG [PAST]” or “TROUBLE DIAG RECORD”)



DTC No.	Trouble diagnosis name	DTC detecting condition	Possible cause
B1118 B1119	SATELLITE SENS LH [UNIT FAIL]	LH satellite sensor is out of order.	<ul style="list-style-type: none"> <li>• Disconnection of wiring harness.</li> <li>• Internal breakdown in LH satellite sensor.</li> <li>• Internal breakdown in diagnosis sensor unit (ACU).</li> </ul>

**DTC CONFIRMATION PROCEDURE (With CONSULT-III)**

**1.INSPECTION START**

Turn ignition switch ON.

>> GO TO 2.

**2.CHECK SELF-DIAG RESULT**

Check the screen of CONSULT-III.

Is malfunctioning part detected?

- YES >> Refer to [SRC-240, "Diagnosis Procedure"](#).
- NO >> **INSPECTION END.**

**DTC CONFIRMATION PROCEDURE (Without CONSULT-III)**

**NOTE:**

- SRS will not enter diagnosis mode if no malfunction is detected in user mode.

**1.INSPECTION START**

Turn ignition switch ON.

>> GO TO 2.

< DTC/CIRCUIT DIAGNOSIS >

---

## 2.CHECK AIR BAG WARNING LAMP

---

Check the warning lamp status.

Is malfunctioning part detected?

- YES >> Refer to [SRC-303, "DTC Index"](#).  
NO >> **INSPECTION END.**

### Diagnosis Procedure

INFOID:000000005252933

With CONSULT-III

#### **WARNING:**

- Before servicing, turn ignition switch OFF, disconnect both battery terminals and wait at least 3 minutes. (To discharge backup capacitor.)
- Do not use unspecified tester or other measuring device.

### DIAGNOSTIC PROCEDURE

---

## 1.CHECK HARNESS CONNECTOR

---

Check the connection of harness connector.

Is the inspection result normal?

- YES >> GO TO 2.  
NO >> Repair or replace harness connector.

---

## 2.CHECK WIRING HARNESS

---

Check the wiring harness externals.

Is the inspection result normal?

- YES >> GO TO 3.  
NO >> Repair or replace wiring harness.

---

## 3.CHECK SATELLITE SENSOR

---

1. Replace LH satellite sensor.
2. Check the screen of CONSULT-III.

Is the inspection result normal?

- YES >> **INSPECTION END.**  
NO >> Check the intermittent incident. Refer to [GI-40, "Intermittent Incident"](#).



B1120, B1121 SATELLITE SENS LH

Description

INFOID:000000005252934

DTC B1120, B1121 [COMM FAIL] SATELLITE SENS LH

Main "G" sensor generates signal voltage, when it detects deceleration beyond the specified level by vehicle side collision.

OPERATION

When ACU defines both signal voltage of the "G" sensor and the Safing sensor to be that of collision which exceeds specified level, the driving circuit switches on and feeds the electric ignitor of both the side air bag and curtain air bag.

STRUCTURE

Integrated type of the G sensor element for side collision with output terminals for signal voltage.

INSTALLATION

LH satellite sensor is installed at the underside of center pillar with fixed nuts.

DTC Logic

INFOID:000000005252935

DTC DETECTION LOGIC

With CONSULT-III

DTC No. Index ("SELF-DIAG [CURRENT]"), ("SELF-DIAG [PAST]" or "TROUBLE DIAG RECORD")

SRC

DTC No.	Trouble diagnosis name	DTC detecting condition	Possible cause
B1120 B1121	SATELLITE SENS LH [COMM FAIL] [UNMATCH]	LH satellite sens is out of order.	<ul style="list-style-type: none"> <li>• Disconnection of wiring harness.</li> <li>• Internal breakdown in LH satellite sens.</li> <li>• Internal breakdown in diagnosis sensor unit (ACU).</li> </ul>

DTC CONFIRMATION PROCEDURE (With CONSULT-III)

1.INSPECTION START

Turn ignition switch ON.

>> GO TO 2.

2.CHECK SELF-DIAG RESULT

Check the screen of CONSULT-III.

Is malfunctioning part detected?

- YES >> Refer to [SRC-242, "Diagnosis Procedure"](#).
- NO >> **INSPECTION END.**

DTC CONFIRMATION PROCEDURE (Without CONSULT-III)

NOTE:

- SRS will not enter diagnosis mode if no malfunction is detected in user mode.

1.INSPECTION START

Turn ignition switch ON.

>> GO TO 2.

---

## 2.CHECK AIR BAG WARNING LAMP

---

Check the warning lamp status.

Is malfunctioning part detected?

- YES >> Refer to [SRC-303, "DTC Index"](#).  
NO >> **INSPECTION END.**

### Diagnosis Procedure

INFOID:000000005252936

With CONSULT-III

#### **WARNING:**

- Before servicing, turn ignition switch OFF, disconnect both battery terminals and wait at least 3 minutes. (To discharge backup capacitor.)
- Do not use unspecified tester or other measuring device.

### DIAGNOSTIC PROCEDURE

#### 1.CHECK HARNESS CONNECTOR

---

Check the connection of harness connector.

Is the inspection result normal?

- YES >> GO TO 2.  
NO >> Repair or replace harness connector.

#### 2.CHECK WIRING HARNESS

---

Check the wiring harness externals.

Is the inspection result normal?

- YES >> GO TO 3.  
NO >> Repair or replace wiring harness.

#### 3.CHECK SATELLITE SENSOR

---

1. Replace LH satellite sensor.
2. Check the screen of CONSULT-III.

Is the inspection result normal?

- YES >> **INSPECTION END.**  
NO >> Check the intermittent incident. Refer to [GI-40, "Intermittent Incident"](#).

# B1122, B1123, B1124, B1125, B1126, B1127 DIAGNOSIS SENSOR UNIT

< DTC/CIRCUIT DIAGNOSIS >

[FOR MEXICO]

## B1122, B1123, B1124, B1125, B1126, B1127 DIAGNOSIS SENSOR UNIT

### Description

INFOID:000000005252937

### DTC B1122, B1123, B1124, B1125, B1126, B1127 DIAGNOSIS SENSOR UNIT

Detects the whole SRS electrical system and displays the malfunction either by illuminating or blinking the air bag warning lamp in the combination meter. Malfunctioning part can be detected by on board self-diagnosis system and electro-diagnosis tester CONSULT-III.

### OPERATION

It detects a shock that exceeds specified level and monitors such systems as the driver and passenger air bag, side air bag, curtain air bag, pre-tensioner seat belts operate properly.

### STRUCTURE

It contains the "G" sensors for both frontal and side collisions and spare battery function in case of main battery damage in collision.

### INSTALLATION

SRS diagnosis sensor unit is installed under the center console with fixed bolts.

### DTC Logic

INFOID:000000005252938

### DTC DETECTION LOGIC

With CONSULT-III

DTC No. Index ("SELF-DIAG [CURRENT]"), ("SELF-DIAG [PAST]" or "TROUBLE DIAG RECORD")

DTC No.	Trouble diagnosis name	DTC detecting condition	Possible cause
B1122 B1123 B1124 B1125 B1126 B1127	CONTROL UNIT	Diagnosis sensor unit is out of order.	Internal breakdown in diagnosis sensor unit (ACU).

### DTC CONFIRMATION PROCEDURE (With CONSULT-III)

#### 1.INSPECTION START

Turn ignition switch ON.

>> GO TO 2.

#### 2.CHECK SELF-DIAG RESULT

Check the screen of CONSULT-III.

Is malfunctioning part detected?

- YES >> Refer to [SRC-244. "Diagnosis Procedure"](#).
- NO >> **INSPECTION END.**

### DTC CONFIRMATION PROCEDURE (Without CONSULT-III)

#### NOTE:

- SRS will not enter diagnosis mode if no malfunction is detected in user mode.

#### 1.INSPECTION START

Turn ignition switch ON.

A  
B  
C  
D  
E  
F  
G  
I  
J  
K  
L  
M  
N  
O  
P

SRC

# B1122, B1123, B1124, B1125, B1126, B1127 DIAGNOSIS SENSOR UNIT

< DTC/CIRCUIT DIAGNOSIS >

[FOR MEXICO]

>> GO TO 2.

## 2.CHECK AIR BAG WARNING LAMP

Check the warning lamp status.

Is malfunctioning part detected?

YES >> Refer to [SRC-303, "DTC Index"](#).

NO >> **INSPECTION END.**

## Diagnosis Procedure

INFOID:000000005252939

With CONSULT-III

### **WARNING:**

- **Before servicing, turn ignition switch OFF, disconnect both battery terminals and wait at least 3 minutes. (To discharge backup capacitor.)**
- **Do not use unspecified tester or other measuring device.**

## DIAGNOSTIC PROCEDURE

### 1.CHECK HARNESS CONNECTOR

Check the connection of harness connector.

Is the inspection result normal?

YES >> GO TO 2.

NO >> Repair or replace harness connectors.

### 2.CHECK WIRING HARNESS

Check the wiring harness externals.

Is the inspection result normal?

YES >> GO TO 3.

NO >> Repair or replace wiring harness.

### 3.CHECK DIAGNOSIS SENSOR UNIT

1. Replace diagnosis sensor unit (ACU).

2. Check the screen of CONSULT-III.

Is the inspection result normal?

YES >> **INSPECTION END.**

NO >> Check the intermittent incident. Refer to [GI-40, "Intermittent Incident"](#).

B1129 SIDE MODULE RH

Description

INFOID:000000005252940

DTC B1129 [OPEN] SIDE MODULE RH

For front RH side air bag module, crash is judged by main “G” sensor output signal (left side: left satellite sensor, right side: right satellite sensor) and sub “G” sensor (right and left GP in center unit).

OPERATION

In the case of a collision whose acceleration exceeds the specified level, the ignition materials are ignited by electric ignition system. The system burns and introduces the chemical reaction of gas generating materials to generate hot gases that flow into the air bag through a filter and expand the bag.

STRUCTURE

Front RH side air bag module mainly consists of air bag and inflator which inflates air bag.

INSTALLATION

Front RH side air bag module is installed on the side of front seat back with fixed nuts.

DTC Logic

INFOID:000000005252941

DTC DETECTION LOGIC

With CONSULT-III

DTC No. Index (“SELF-DIAG [CURRENT]”), (“SELF-DIAG [PAST]” or “TROUBLE DIAG RECORD”)

SRC

DTC No.	Trouble diagnosis name	DTC detecting condition	Possible cause
B1129	SIDE MODULE RH [OPEN]	Front RH side air bag module circuit is open.	<ul style="list-style-type: none"> <li>• Disconnection of wiring harness and open.</li> <li>• Internal breakdown in front RH side air bag module.</li> <li>• Internal breakdown in diagnosis sensor unit (ACU).</li> </ul>

DTC CONFIRMATION PROCEDURE (With CONSULT-III)

1.INSPECTION START

Turn ignition switch ON.

>> GO TO 2.

2.CHECK SELF-DIAG RESULT

Check the screen of CONSULT-III.

Is malfunctioning part detected?

- YES >> Refer to [SRC-246, "Diagnosis Procedure"](#).
- NO >> **INSPECTION END.**

DTC CONFIRMATION PROCEDURE (Without CONSULT-III)

**NOTE:**

- SRS will not enter diagnosis mode if no malfunction is detected in user mode.

1.INSPECTION START

Turn ignition switch ON.

>> GO TO 2.

&lt; DTC/CIRCUIT DIAGNOSIS &gt;

**2.CHECK AIR BAG WARNING LAMP**

Check the warning lamp status.

Is malfunctioning part detected?

- YES >> Refer to [SRC-303, "DTC Index"](#).  
 NO >> **INSPECTION END.**

## Diagnosis Procedure

INFOID:000000005252942

With CONSULT-III

**WARNING:**

- Before servicing, turn ignition switch OFF, disconnect both battery terminals and wait at least 3 minutes. (To discharge backup capacitor.)
- Do not use unspecified tester or other measuring device.

## DIAGNOSTIC PROCEDURE

**1.CHECK HARNESS CONNECTOR**

Check the connection of harness connector.

Is the inspection result normal?

- YES >> GO TO 2.  
 NO >> Repair or replace harness connector.

**2.CHECK WIRING HARNESS**

Check the wiring harness externals.

Is the inspection result normal?

- YES >> GO TO 3.  
 NO >> Repair or replace wiring harness.

**3.CHECK FRONT SIDE AIR BAG MODULE**

1. Replace front RH side air bag module.
2. Check the screen of CONSULT-III.

Is the inspection result normal?

- YES >> **INSPECTION END.**  
 NO >> Check the intermittent incident. Refer to [GI-40, "Intermittent Incident"](#).

B1130 SIDE MODULE RH

Description

INFOID:000000005252943

DTC B1130 [VB-SHORT] SIDE MODULE RH

For front RH side air bag module, crash is judged by main “G” sensor output signal (left side: left satellite sensor, right side: right satellite sensor) and sub “G” sensor (right and left GP in center unit).

OPERATION

In the case of a collision whose acceleration exceeds the specified level, the ignition materials are ignited by electric ignition system. The system burns and introduces the chemical reaction of gas generating materials to generate hot gases that flow into the air bag through a filter and expand the bag.

STRUCTURE

Front RH side air bag module mainly consists of air bag and inflator which inflates air bag.

INSTALLATION

Front RH side air bag module is installed on the side of front seatback with fixed nuts.

DTC Logic

INFOID:000000005252944

DTC DETECTION LOGIC

With CONSULT-III

DTC No. Index (“SELF-DIAG [CURRENT]”), (“SELF-DIAG [PAST]” or “TROUBLE DIAG RECORD”)

SRC

DTC No.	Trouble diagnosis name	DTC detecting condition	Possible cause
B1130	SIDE MODULE RH [VB-SHORT]	Front RH side air bag module circuit is shorted to some power supply circuit.	<ul style="list-style-type: none"> <li>• Disconnection of wiring harness and short.</li> <li>• Internal breakdown in front RH side air bag module.</li> <li>• Internal breakdown in diagnosis sensor unit (ACU).</li> </ul>

DTC CONFIRMATION PROCEDURE (With CONSULT-III)

1.INSPECTION START

Turn ignition switch ON.

>> GO TO 2.

2.CHECK SELF-DIAG RESULT

Check the screen of CONSULT-III.

Is malfunctioning part detected?

- YES >> Refer to [SRC-248, "Diagnosis Procedure"](#).
- NO >> **INSPECTION END.**

DTC CONFIRMATION PROCEDURE (Without CONSULT-III)

**NOTE:**

- SRS will not enter diagnosis mode if no malfunction is detected in user mode.

1.INSPECTION START

Turn ignition switch ON.

>> GO TO 2.

< DTC/CIRCUIT DIAGNOSIS >

---

## 2.CHECK AIR BAG WARNING LAMP

---

Check the warning lamp status.

Is malfunctioning part detected?

- YES >> Refer to [SRC-303, "DTC Index"](#).
- NO >> **INSPECTION END.**

### Diagnosis Procedure

INFOID:000000005252945

With CONSULT-III

#### **WARNING:**

- **Before servicing, turn ignition switch OFF, disconnect both battery terminals and wait at least 3 minutes. (To discharge backup capacitor.)**
- **Do not use unspecified tester or other measuring device.**

### DIAGNOSTIC PROCEDURE

---

#### 1.CHECK HARNESS CONNECTOR

---

Check the connection of harness connector.

Is the inspection result normal?

- YES >> GO TO 2.
- NO >> Repair or replace harness connector.

---

#### 2.CHECK WIRING HARNESS

---

Check the wiring harness externals.

Is the inspection result normal?

- YES >> GO TO 3.
- NO >> Repair or replace wiring harness.

---

#### 3.CHECK FRONT SIDE AIR BAG MODULE

---

1. Replace front RH side air bag module.
2. Check the screen of CONSULT-III.

Is the inspection result normal?

- YES >> **INSPECTION END.**
- NO >> Check the intermittent incident. Refer to [GI-40, "Intermittent Incident"](#).



B1131 SIDE MODULE RH

Description

INFOID:000000005252946

DTC B1131 [GND-SHORT] SIDE MODULE RH

For front RH side air bag module, crash is judged by main “G” sensor output signal (left side: left satellite sensor, right side: right satellite sensor) and sub “G” sensor (right and left GP in center unit).

OPERATION

In the case of a collision whose acceleration exceeds the specified level, the ignition materials are ignited by electric ignition system. The system burns and introduces the chemical reaction of gas generating materials to generate hot gases that flow into the air bag through a filter and expand the bag.

STRUCTURE

Front RH side air bag module mainly consists of air bag and inflator which inflates air bag.

INSTALLATION

Front RH side air bag module is installed on the side of front seatback with fixed nuts.

DTC Logic

INFOID:000000005252947

DTC DETECTION LOGIC

With CONSULT-III

DTC No. Index (“SELF-DIAG [CURRENT]”), (“SELF-DIAG [PAST]” or “TROUBLE DIAG RECORD”)

SRC

DTC No.	Trouble diagnosis name	DTC detecting condition	Possible cause
B1131	SIDE MODULE RH [GND-SHORT]	Front RH side air bag module circuit is shorted to ground.	<ul style="list-style-type: none"> <li>• Disconnection of wiring harness and short.</li> <li>• Internal breakdown in front RH side air bag module.</li> <li>• Internal breakdown in diagnosis sensor unit (ACU).</li> </ul>

DTC CONFIRMATION PROCEDURE (With CONSULT-III)

1.INSPECTION START

Turn ignition switch ON.

>> GO TO 2.

2.CHECK SELF-DIAG RESULT

Check the screen of CONSULT-III.

Is malfunctioning part detected?

YES >> Refer to [SRC-250, "Diagnosis Procedure"](#).

NO >> **INSPECTION END.**

DTC CONFIRMATION PROCEDURE (Without CONSULT-III)

**NOTE:**

- SRS will not enter diagnosis mode if no malfunction is detected in user mode.

1.INSPECTION START

Turn ignition switch ON.

>> GO TO 2.

&lt; DTC/CIRCUIT DIAGNOSIS &gt;

**2.CHECK AIR BAG WARNING LAMP**

Check the warning lamp status.

Is malfunctioning part detected?

- YES >> Refer to [SRC-303, "DTC Index"](#).  
 NO >> **INSPECTION END.**

## Diagnosis Procedure

INFOID:000000005252948

With CONSULT-III

**WARNING:**

- Before servicing, turn ignition switch OFF, disconnect both battery terminals and wait at least 3 minutes. (To discharge backup capacitor.)
- Do not use unspecified tester or other measuring device.

## DIAGNOSTIC PROCEDURE

**1.CHECK HARNESS CONNECTOR**

Check the connection of harness connector.

Is the inspection result normal?

- YES >> GO TO 2.  
 NO >> Repair or replace harness connector.

**2.CHECK WIRING HARNESS**

Check the wiring harness externals.

Is the inspection result normal?

- YES >> GO TO 3.  
 NO >> Repair or replace wiring harness.

**3.CHECK FRONT SIDE AIR BAG MODULE**

1. Replace front RH side air bag module.
2. Check the screen of CONSULT-III.

Is the inspection result normal?

- YES >> **INSPECTION END.**  
 NO >> Check the intermittent incident. Refer to [GI-40, "Intermittent Incident"](#).

B1132 SIDE MODULE RH

Description

INFOID:000000005252949

DTC B1132 [SHORT] SIDE MODULE RH

For front RH side air bag module, crash is judged by main “G” sensor output signal (left side: left satellite sensor, right side: right satellite sensor) and sub “G” sensor (right and left GP in center unit).

OPERATION

In the case of a collision whose acceleration exceeds the specified level, the ignition materials are ignited by electric ignition system. The system burns and introduces the chemical reaction of gas generating materials to generate hot gases that flow into the air bag through a filter and expand the bag.

STRUCTURE

Front RH side air bag module mainly consists of air bag and inflator which inflates air bag.

INSTALLATION

Front RH side air bag module is installed on the side of front seatback with fixed nuts.

DTC Logic

INFOID:000000005252950

DTC DETECTION LOGIC

With CONSULT-III

DTC No. Index (“SELF-DIAG [CURRENT]”), (“SELF-DIAG [PAST]” or “TROUBLE DIAG RECORD”)

SRC

DTC No.	Trouble diagnosis name	DTC detecting condition	Possible cause
B1132	SIDE MODULE RH [SHORT]	Front RH side air bag module circuit are shorted to each other.	<ul style="list-style-type: none"> <li>• Disconnection of wiring harness and short.</li> <li>• Internal breakdown in front RH side air bag module.</li> <li>• Internal breakdown in diagnosis sensor unit (ACU).</li> </ul>

DTC CONFIRMATION PROCEDURE (With CONSULT-III)

1.INSPECTION START

Turn ignition switch ON.

>> GO TO 2.

2.CHECK SELF-DIAG RESULT

Check the screen of CONSULT-III.

Is malfunctioning part detected?

YES >> Refer to [SRC-252, "Diagnosis Procedure"](#).

NO >> **INSPECTION END.**

DTC CONFIRMATION PROCEDURE (Without CONSULT-III)

**NOTE:**

- SRS will not enter diagnosis mode if no malfunction is detected in user mode.

1.INSPECTION START

Turn ignition switch ON.

>> GO TO 2.

&lt; DTC/CIRCUIT DIAGNOSIS &gt;

**2.CHECK AIR BAG WARNING LAMP**

Check the warning lamp status.

Is malfunctioning part detected?

- YES >> Refer to [SRC-303, "DTC Index"](#).  
 NO >> **INSPECTION END.**

## Diagnosis Procedure

INFOID:000000005252951

With CONSULT-III

**WARNING:**

- Before servicing, turn ignition switch OFF, disconnect both battery terminals and wait at least 3 minutes. (To discharge backup capacitor.)
- Do not use unspecified tester or other measuring device.

## DIAGNOSTIC PROCEDURE

**1.CHECK HARNESS CONNECTOR**

Check the connection of harness connector.

Is the inspection result normal?

- YES >> GO TO 2.  
 NO >> Repair or replace harness connector.

**2.CHECK WIRING HARNESS**

Check the wiring harness externals.

Is the inspection result normal?

- YES >> GO TO 3.  
 NO >> Repair or replace wiring harness.

**3.CHECK FRONT SIDE AIR BAG MODULE**

1. Replace front RH side air bag module.
2. Check the screen of CONSULT-III.

Is the inspection result normal?

- YES >> **INSPECTION END.**  
 NO >> Check the intermittent incident. Refer to [GI-40, "Intermittent Incident"](#).

B1134 SIDE MODULE LH

Description

INFOID:000000005252952

DTC B1134 [OPEN] SIDE MODULE LH

For front LH side air bag module, crash is judged by main “G” sensor output signal (left side: left satellite sensor, right side: right satellite sensor) and sub “G” sensor (right and left GP in center unit).

OPERATION

In the case of a collision whose acceleration exceeds the specified level, the ignition materials are ignited by electric ignition system. The system burns and introduces the chemical reaction of gas generating materials to generate hot gases that flow into the air bag through a filter and expand the bag.

STRUCTURE

Front LH side air bag module mainly consists of air bag and inflator which inflates air bag.

INSTALLATION

Front LH side air bag module is installed on the side of front seatback with fixed nuts.

DTC Logic

INFOID:000000005252953

DTC DETECTION LOGIC

With CONSULT-III

DTC No. Index (“SELF-DIAG [CURRENT]”), (“SELF-DIAG [PAST]” or “TROUBLE DIAG RECORD”)

SRC

DTC No.	Trouble diagnosis name	DTC detecting condition	Possible cause
B1134	SIDE MODULE LH [OPEN]	Front LH side air bag module circuit is open.	<ul style="list-style-type: none"> <li>• Disconnection of wiring harness and open.</li> <li>• Internal breakdown in front LH side air bag module.</li> <li>• Internal breakdown in diagnosis sensor unit (ACU).</li> </ul>

DTC CONFIRMATION PROCEDURE (With CONSULT-III)

1.INSPECTION START

Turn ignition switch ON.

>> GO TO 2.

2.CHECK SELF-DIAG RESULT

Check the screen of CONSULT-III.

Is malfunctioning part detected?

YES >> Refer to [SRC-254, "Diagnosis Procedure"](#).

NO >> **INSPECTION END.**

DTC CONFIRMATION PROCEDURE (Without CONSULT-III)

**NOTE:**

- SRS will not enter diagnosis mode if no malfunction is detected in user mode.

1.INSPECTION START

Turn ignition switch ON.

>> GO TO 2.

&lt; DTC/CIRCUIT DIAGNOSIS &gt;

**2.CHECK AIR BAG WARNING LAMP**

Check the warning lamp status.

Is malfunctioning part detected?YES >> Refer to [SRC-303, "DTC Index"](#).NO >> **INSPECTION END.**

## Diagnosis Procedure

INFOID:000000005252954

With CONSULT-III

**WARNING:**

- Before servicing, turn ignition switch OFF, disconnect both battery terminals and wait at least 3 minutes. (To discharge backup capacitor.)
- Do not use unspecified tester or other measuring device.

## DIAGNOSTIC PROCEDURE

**1.CHECK HARNESS CONNECTOR**

Check the connection of harness connector.

Is the inspection result normal?

YES &gt;&gt; GO TO 2.

NO &gt;&gt; Repair or replace harness connector.

**2.CHECK WIRING HARNESS**

Check the wiring harness externals.

Is the inspection result normal?

YES &gt;&gt; GO TO 3.

NO &gt;&gt; Replace wiring harness.

**3.CHECK FRONT SIDE AIR BAG MODULE**

1. Replace front LH side air bag module.

2. Check the screen of CONSULT-III.

Is the inspection result normal?YES >> **INSPECTION END.**NO >> Check the intermittent incident. Refer to [GI-40, "Intermittent Incident"](#).

# B1135 SIDE MODULE LH

< DTC/CIRCUIT DIAGNOSIS >

[FOR MEXICO]

## B1135 SIDE MODULE LH

### Description

INFOID:000000005252955

### DTC B1135 [VB-SHORT] SIDE MODULE LH

For front LH side air bag module, crash is judged by main "G" sensor output signal (left side: left satellite sensor, right side: right satellite sensor) and sub "G" sensor (right and left GP in center unit).

### OPERATION

In the case of a collision whose acceleration exceeds the specified level, the ignition materials are ignited by electric ignition system. The system burns and introduces the chemical reaction of gas generating materials to generate hot gases that flow into the air bag through a filter and expand the bag.

### STRUCTURE

Front LH side air bag module mainly consists of air bag and inflator which inflates air bag.

### INSTALLATION

Front LH side air bag module is installed on the side of front seatback with fixed nuts.

### DTC Logic

INFOID:000000005252956

### DTC DETECTION LOGIC

With CONSULT-III

DTC No. Index ("SELF-DIAG [CURRENT]"), ("SELF-DIAG [PAST]" or "TROUBLE DIAG RECORD")

DTC No.	Trouble diagnosis name	DTC detecting condition	Possible cause
B1135	SIDE MODULE LH [VB-SHORT]	Front LH side air bag module circuit is shorted to some power supply circuit.	<ul style="list-style-type: none"><li>• Disconnection of wiring harness and short.</li><li>• Internal breakdown in front LH side air bag module.</li><li>• Internal breakdown in diagnosis sensor unit (ACU).</li></ul>

### DTC CONFIRMATION PROCEDURE (With CONSULT-III)

#### 1.INSPECTION START

Turn ignition switch ON.

>> GO TO 2.

#### 2.CHECK SELF-DIAG RESULT

Check the screen of CONSULT-III.

Is malfunctioning part detected?

YES >> Refer to [SRC-256, "Diagnosis Procedure"](#).

NO >> **INSPECTION END.**

### DTC CONFIRMATION PROCEDURE (Without CONSULT-III)

#### NOTE:

- SRS will not enter diagnosis mode if no malfunction is detected in user mode.

#### 1.INSPECTION START

Turn ignition switch ON.

>> GO TO 2.

&lt; DTC/CIRCUIT DIAGNOSIS &gt;

---

**2.CHECK AIR BAG WARNING LAMP**

---

Check the warning lamp status.

Is malfunctioning part detected?YES >> Refer to [SRC-303, "DTC Index"](#).NO >> **INSPECTION END.**

## Diagnosis Procedure

INFOID:000000005252957

With CONSULT-III

**WARNING:**

- Before servicing, turn ignition switch OFF, disconnect both battery terminals and wait at least 3 minutes. (To discharge backup capacitor.)
- Do not use unspecified tester or other measuring device.

## DIAGNOSTIC PROCEDURE

**1.CHECK HARNESS CONNECTOR**

---

Check the connection of harness connector.

Is the inspection result normal?

YES &gt;&gt; GO TO 2.

NO &gt;&gt; Repair or replace harness connector.

**2.CHECK WIRING HARNESS**

---

Check the wiring harness externals.

Is the inspection result normal?

YES &gt;&gt; GO TO 3.

NO &gt;&gt; Repair or replace wiring harness.

**3.CHECK FRONT SIDE AIR BAG MODULE**

---

1. Replace front LH side air bag module.
2. Check the screen of CONSULT-III.

Is the inspection result normal?YES >> **INSPECTION END.**NO >> Check the intermittent incident. Refer to [GI-40, "Intermittent Incident"](#).



B1136 SIDE MODULE LH

Description

INFOID:000000005252958

DTC B1136 [GND-SHORT] SIDE MODULE LH

For front LH side air bag module, crash is judged by main “G” sensor output signal (left side: left satellite sensor, right side: right satellite sensor) and sub “G” sensor (right and left GP in center unit).

OPERATION

In the case of a collision whose acceleration exceeds the specified level, the ignition materials are ignited by electric ignition system. The system burns and introduces the chemical reaction of gas generating materials to generate hot gases that flow into the air bag through a filter and expand the bag.

STRUCTURE

Front LH side air bag module mainly consists of air bag and inflator which inflates air bag.

INSTALLATION

Front LH side air bag module is installed on the side of front seatback with fixed nuts.

DTC Logic

INFOID:000000005252959

DTC DETECTION LOGIC

With CONSULT-III

DTC No. Index (“SELF-DIAG [CURRENT]”), (“SELF-DIAG [PAST]” or “TROUBLE DIAG RECORD”)

SRC

DTC No.	Trouble diagnosis name	DTC detecting condition	Possible cause
B1136	SIDE MODULE LH [GND-SHORT]	Front LH side air bag module circuit is shorted to ground.	<ul style="list-style-type: none"> <li>• Disconnection of wiring harness and short.</li> <li>• Internal breakdown in front LH side air bag module.</li> <li>• Internal breakdown in diagnosis sensor unit (ACU).</li> </ul>

DTC CONFIRMATION PROCEDURE (With CONSULT-III)

1.INSPECTION START

Turn ignition switch ON.

>> GO TO 2.

2.CHECK SELF-DIAG RESULT

Check the screen of CONSULT-III.

Is malfunctioning part detected?

- YES >> Refer to [SRC-258, "Diagnosis Procedure"](#).
- NO >> **INSPECTION END.**

DTC CONFIRMATION PROCEDURE (Without CONSULT-III)

**NOTE:**

- SRS will not enter diagnosis mode if no malfunction is detected in user mode.

1.INSPECTION START

Turn ignition switch ON.

>> GO TO 2.

&lt; DTC/CIRCUIT DIAGNOSIS &gt;

---

**2.CHECK AIR BAG WARNING LAMP**

---

Check the warning lamp status.

Is malfunctioning part detected?YES >> Refer to [SRC-303, "DTC Index"](#).NO >> **INSPECTION END.**

## Diagnosis Procedure

INFOID:000000005252960

With CONSULT-III

**WARNING:**

- Before servicing, turn ignition switch OFF, disconnect both battery terminals and wait at least 3 minutes. (To discharge backup capacitor.)
- Do not use unspecified tester or other measuring device.

## DIAGNOSTIC PROCEDURE

**1.CHECK HARNESS CONNECTOR**

---

Check the connection of harness connector.

Is the inspection result normal?

YES &gt;&gt; GO TO 2.

NO &gt;&gt; Repair or replace harness connector.

**2.CHECK WIRING HARNESS**

---

Check the wiring harness externals.

Is the inspection result normal?

YES &gt;&gt; GO TO 3.

NO &gt;&gt; Repair or replace wiring harness.

**3.CHECK FRONT SIDE AIR BAG MODULE**

---

1. Replace front LH side air bag module.
2. Check the screen of CONSULT-III.

Is the inspection result normal?YES >> **INSPECTION END.**NO >> Check the intermittent incident. Refer to [GI-40, "Intermittent Incident"](#).

B1137 SIDE MODULE LH

Description

INFOID:000000005252961

DTC B1137 [SHORT] SIDE MODULE LH

For front LH side air bag module, crash is judged by main “G” sensor output signal (left side: left satellite sensor, right side: right satellite sensor) and sub “G” sensor (right and left GP in center unit).

OPERATION

In the case of a collision whose acceleration exceeds the specified level, the ignition materials are ignited by electric ignition system. The system burns and introduces the chemical reaction of gas generating materials to generate hot gases that flow into the air bag through a filter and expand the bag.

STRUCTURE

Front LH side air bag module mainly consists of air bag and inflator which inflates air bag.

INSTALLATION

Front LH side air bag module is installed on the side of front seatback with fixed nuts.

DTC Logic

INFOID:000000005252962

DTC DETECTION LOGIC

With CONSULT-III

DTC No. Index (“SELF-DIAG [CURRENT]”), (“SELF-DIAG [PAST]” or “TROUBLE DIAG RECORD”)

SRC

DTC No.	Trouble diagnosis name	DTC detecting condition	Possible cause
B1137	SIDE MODULE LH [SHORT]	Front LH side air bag module circuit are shorted to each other.	<ul style="list-style-type: none"> <li>• Disconnection of wiring harness and short.</li> <li>• Internal breakdown in front LH side air bag module.</li> <li>• Internal breakdown in diagnosis sensor unit (ACU).</li> </ul>

DTC CONFIRMATION PROCEDURE (With CONSULT-III)

1.INSPECTION START

Turn ignition switch ON.

>> GO TO 2.

2.CHECK SELF-DIAG RESULT

Check the screen of CONSULT-III.

Is malfunctioning part detected?

YES >> Refer to [SRC-260, "Diagnosis Procedure"](#).

NO >> **INSPECTION END.**

DTC CONFIRMATION PROCEDURE (Without CONSULT-III)

**NOTE:**

- SRS will not enter diagnosis mode if no malfunction is detected in user mode.

1.INSPECTION START

Turn ignition switch ON.

>> GO TO 2.

&lt; DTC/CIRCUIT DIAGNOSIS &gt;

**2.**CHECK AIR BAG WARNING LAMP

Check the warning lamp status.

Is malfunctioning part detected?YES >> Refer to [SRC-303, "DTC Index"](#).NO >> **INSPECTION END.**

## Diagnosis Procedure

INFOID:000000005252963

With CONSULT-III

**WARNING:**

- Before servicing, turn ignition switch OFF, disconnect both battery terminal and wait at least 3 minutes. (To discharge backup capacitor.)
- Do not use un specified tester or other measuring device.

## DIAGNOSTIC PROCEDURE

**1.**CHECK HARNESS CONNECTOR

Check the connection of harness connector.

Is the inspection result normal?

YES &gt;&gt; GO TO 2.

NO &gt;&gt; Repair or replace harness connector.

**2.**CHECK WIRING HARNESS

Check the wiring harness externals.

Is the inspection result normal?

YES &gt;&gt; GO TO 3.

NO &gt;&gt; Repair or replace wiring harness.

**3.**CHECK FRONT SIDE AIR BAG MODULE

1. Replace front LH side air bag module.

2. Check the screen of CONSULT-III.

Is the inspection result normal?YES >> **INSPECTION END.**NO >> Check the intermittent incident. Refer to [GI-40, "Intermittent Incident"](#).

# B1138, B1139, B1140, B1141, B1142, B1143 DIAGNOSIS SENSOR UNIT

< DTC/CIRCUIT DIAGNOSIS >

[FOR MEXICO]

## B1138, B1139, B1140, B1141, B1142, B1143 DIAGNOSIS SENSOR UNIT

### Description

INFOID:000000005252964

#### DTC B1138, B1139, B1140, B1141, B1142, B1143 DIAGNOSIS SENSOR UNIT

Detects the whole SRS electrical system and displays the malfunction either by illuminating or blinking the air bag warning lamp in the combination meter. Malfunctioning part can be detected by on board self-diagnosis system and electro-diagnosis tester CONSULT-III.

### OPERATION

It detects a shock that exceeds specified level and monitors such systems as the driver and passenger air bag, side air bag, curtain air bag, pre-tensioner seat belts operate properly.

### STRUCTURE

It contains the "G" sensors for both frontal and side collisions and spare battery function in case of main battery damage in collision.

### INSTALLATION

SRS diagnosis sensor unit is installed under the center console with fixed bolts.

### DTC Logic

INFOID:000000005252965

#### DTC DETECTION LOGIC

With CONSULT-III

DTC No. Index ("SELF-DIAG [CURRENT]"), ("SELF-DIAG [PAST]" or "TROUBLE DIAG RECORD")

DTC No.	Trouble diagnosis name	DTC detecting condition	Possible cause
B1138 B1139 B1140 B1141 B1142 B1143	CONTROL UNIT	Diagnosis sensor unit is out of order.	Internal breakdown in diagnosis sensor unit (ACU).

#### DTC CONFIRMATION PROCEDURE (With CONSULT-III)

##### 1.INSPECTION START

Turn ignition switch ON.

>> GO TO 2.

##### 2.CHECK SELF-DIAG RESULT

Check the screen of CONSULT-III.

Is malfunctioning part detected?

- YES >> Refer to [SRC-262. "Diagnosis Procedure"](#).
- NO >> **INSPECTION END.**

#### DTC CONFIRMATION PROCEDURE (Without CONSULT-III)

##### NOTE:

- SRS will not enter diagnosis mode if no malfunction is detected in user mode.

##### 1.INSPECTION START

Turn ignition switch ON.

A  
B  
C  
D  
E  
F  
G  
I  
J  
K  
L  
M  
N  
O  
P

SRC

# B1138, B1139, B1140, B1141, B1142, B1143 DIAGNOSIS SENSOR UNIT

[FOR MEXICO]

< DTC/CIRCUIT DIAGNOSIS >

---

>> GO TO 2.

## 2.CHECK AIR BAG WARNING LAMP

---

Check the warning lamp status.

Is malfunctioning part detected?

YES >> Refer to [SRC-303, "DTC Index"](#).

NO >> **INSPECTION END.**

## Diagnosis Procedure

INFOID:000000005252966

With CONSULT-III

### **WARNING:**

- **Before servicing, turn ignition switch OFF, disconnect both battery terminals and wait at least 3 minutes. (To discharge backup capacitor.)**
- **Do not use unspecified tester or other measuring device.**

## DIAGNOSTIC PROCEDURE

### 1.CHECK HARNESS CONNECTOR

---

Check the connection of harness connector.

Is the inspection result normal?

YES >> GO TO 2.

NO >> Repair or replace harness connectors.

### 2.CHECK WIRING HARNESS

---

Check the wiring harness externals.

Is the inspection result normal?

YES >> GO TO 3.

NO >> Replace wiring harness.

### 3.CHECK DIAGNOSIS SENSOR UNIT

---

1. Replace diagnosis sensor unit (ACU).

2. Check the screen of CONSULT-III.

Is the inspection result normal?

YES >> **INSPECTION END.**

NO >> Check the intermittent incident. Refer to [GI-40, "Intermittent Incident"](#).

# B1145 CURTAIN MODULE RH

< DTC/CIRCUIT DIAGNOSIS >

[FOR MEXICO]

## B1145 CURTAIN MODULE RH

### Description

INFOID:000000005252967

### DTC B1145 [OPEN] CURTAIN MODULE RH

For RH side curtain air bag module, crash is judged by main "G" sensor output signal (left side: left satellite sensor, right side: right satellite sensor) and sub "G" sensor (right and left GP in center unit).

### OPERATION

In case of collision whose acceleration exceeds the specified level, the ignition materials are ignited by electric ignition system. The system burns and introduces the chemical reaction of gas generating materials to generate hot gases that flow into the air bag through a filter and expand the bag.

### STRUCTURE

RH side curtain air bag module mainly consists of air bag and inflator which inflates air bag.

### INSTALLATION

RH side curtain air bag module is installed on the roof side with fixed bolts.

### DTC Logic

INFOID:000000005252968

### DTC DETECTION LOGIC

With CONSULT-III

DTC No. Index ("SELF-DIAG [CURRENT]"), ("SELF-DIAG [PAST]" or "TROUBLE DIAG RECORD")

SRC

DTC No.	Trouble diagnosis name	DTC detecting condition	Possible cause
B1145	CURTAIN MODULE RH [OPEN]	RH side curtain air bag module circuit is open.	<ul style="list-style-type: none"> <li>• Disconnection of wiring harness and open.</li> <li>• Internal breakdown in RH side curtain air bag module.</li> <li>• Replace diagnosis sensor unit (ACU).</li> </ul>

### DTC CONFIRMATION PROCEDURE (With CONSULT-III)

#### 1.INSPECTION START

Turn ignition switch ON.

>> GO TO 2.

#### 2.CHECK SELF-DIAG RESULT

Check the screen of CONSULT-III.

Is malfunctioning part detected?

YES >> Refer to [SRC-264, "Diagnosis Procedure"](#).

NO >> **INSPECTION END.**

### DTC CONFIRMATION PROCEDURE (Without CONSULT-III)

#### NOTE:

- SRS will not enter diagnosis mode if no malfunction is detected in user mode.

#### 1.INSPECTION START

Turn ignition switch ON.

>> GO TO 2.

< DTC/CIRCUIT DIAGNOSIS >

---

## 2.CHECK AIR BAG WARNING LAMP

---

Check the warning lamp status.

Is malfunctioning part detected?

- YES >> Refer to [SRC-303, "DTC Index"](#).  
NO >> **INSPECTION END.**

### Diagnosis Procedure

INFOID:000000005252969

With CONSULT-III

#### **WARNING:**

- Before servicing, turn ignition switch OFF, disconnect both battery terminals and wait at least 3 minutes. (To discharge backup capacitor.)
- Do not use unspecified tester or other measuring device.

### DIAGNOSTIC PROCEDURE

---

## 1.CHECK HARNESS CONNECTOR

---

Check the connection of harness connector.

Is the inspection result normal?

- YES >> GO TO 2.  
NO >> Repair or replace harness connector.

---

## 2.CHECK WIRING HARNESS

---

Check the wiring harness externals.

Is the inspection result normal?

- YES >> GO TO 3.  
NO >> Repair or replace wiring harness.

---

## 3.CHECK SIDE CURTAIN AIR BAG MODULE

---

1. Replace RH side curtain air bag module.
2. Check the screen of CONSULT-III.

Is the inspection result normal?

- YES >> **INSPECTION END.**  
NO >> Check the intermittent incident. Refer to [GI-40, "Intermittent Incident"](#).



# B1146 CURTAIN MODULE RH

< DTC/CIRCUIT DIAGNOSIS >

[FOR MEXICO]

## B1146 CURTAIN MODULE RH

### Description

INFOID:000000005252970

### DTC B1146 [VB-SHORT] CURTAIN MODULE RH

For RH side curtain air bag module, crash is judged by main "G" sensor output signal (left side: left satellite sensor, right side: right satellite sensor) and sub "G" sensor (right and left GP in center unit).

### OPERATION

In case of collision whose acceleration exceeds the specified level, the ignition materials are ignited by electric ignition system. The system burns and introduces the chemical reaction of gas generating materials to generate hot gases that flow into the air bag through a filter and expand the bag.

### STRUCTURE

RH side curtain air bag module mainly consists of air bag and inflator which inflates air bag.

### INSTALLATION

RH side curtain air bag module is installed on the roof side with fixed bolts.

### DTC Logic

INFOID:000000005252971

### DTC DETECTION LOGIC

With CONSULT-III

DTC No. Index ("SELF-DIAG [CURRENT]"), ("SELF-DIAG [PAST]" or "TROUBLE DIAG RECORD")

DTC No.	Trouble diagnosis name	DTC detecting condition	Possible cause
B1146	CURTAIN MODULE RH [VB-SHORT]	RH side curtain air bag module circuit is shorted to some power supply circuit.	<ul style="list-style-type: none"> <li>Disconnection of wiring harness and short.</li> <li>Internal breakdown in RH side curtain air bag module.</li> <li>Internal breakdown in diagnosis sensor unit (ACU).</li> </ul>

### DTC CONFIRMATION PROCEDURE (With CONSULT-III)

#### 1.INSPECTION START

Turn ignition switch ON.

>> GO TO 2.

#### 2.CHECK SELF-DIAG RESULT

Check the screen of CONSULT-III.

Is malfunctioning part detected?

YES >> Refer to [SRC-266, "Diagnosis Procedure"](#).

NO >> **INSPECTION END.**

### DTC CONFIRMATION PROCEDURE (Without CONSULT-III)

#### NOTE:

- SRS will not enter diagnosis mode if no malfunction is detected in user mode.

#### 1.INSPECTION START

Turn ignition switch ON.

>> GO TO 2.

A  
B  
C  
D  
E  
F  
G  
I  
J  
K  
L  
M  
N  
O  
P

SRC

< DTC/CIRCUIT DIAGNOSIS >

---

## 2.CHECK AIR BAG WARNING LAMP

---

Check the warning lamp status.

Is malfunctioning part detected?

- YES >> Refer to [SRC-303, "DTC Index"](#).
- NO >> **INSPECTION END.**

### Diagnosis Procedure

INFOID:000000005252972

With CONSULT-III

#### **WARNING:**

- **Before servicing, turn ignition switch OFF, disconnect both battery terminals and wait at least 3 minutes. (To discharge backup capacitor.)**
- **Do not use unspecified tester or other measuring device.**

### DIAGNOSTIC PROCEDURE

---

## 1.CHECK HARNESS CONNECTOR

---

Check the connection of harness connector.

Is the inspection result normal?

- YES >> GO TO 2.
- NO >> Repair or replace harness connector.

---

## 2.CHECK WIRING HARNESS

---

Check the wiring harness externals.

Is the inspection result normal?

- YES >> GO TO 3.
- NO >> Repair or replace wiring harness.

---

## 3.CHECK SIDE CURTAIN AIR BAG MODULE

---

1. Replace RH side curtain air bag module.
2. Check the screen of CONSULT-III.

Is the inspection result normal?

- YES >> **INSPECTION END.**
- NO >> Check the intermittent incident. Refer to [GI-40, "Intermittent Incident"](#).

# B1147 CURTAIN MODULE RH

< DTC/CIRCUIT DIAGNOSIS >

[FOR MEXICO]

## B1147 CURTAIN MODULE RH

### Description

INFOID:000000005252973

### DTC B1147 [GND-SHORT] CURTAIN MODULE RH

For RH side curtain air bag module, crash is judged by main "G" sensor output signal (left side: left satellite sensor, right side: right satellite sensor) and sub "G" sensor (right and left GP in center unit).

### OPERATION

In case of collision whose acceleration exceeds the specified level, the ignition materials are ignited by electric ignition system. The system burns and introduces the chemical reaction of gas generating materials to generate hot gases that flow into the air bag through a filter and expand the bag.

### STRUCTURE

RH side curtain air bag module mainly consists of air bag and inflator which inflates air bag.

### INSTALLATION

RH side curtain air bag module is installed on the roof side with fixed bolts.

### DTC Logic

INFOID:000000005252974

### DTC DETECTION LOGIC

With CONSULT-III

DTC No. Index ("SELF-DIAG [CURRENT]"), ("SELF-DIAG [PAST]" or "TROUBLE DIAG RECORD")

DTC No.	Trouble diagnosis name	DTC detecting condition	Possible cause
B1147	CURTAIN MODULE RH [GND-SHORT]	RH side curtain air bag module circuit is shorted to ground.	<ul style="list-style-type: none"> <li>Disconnection of wiring harness and short.</li> <li>Internal breakdown in RH side curtain air bag module.</li> <li>Replace diagnosis sensor unit (ACU).</li> </ul>

### DTC CONFIRMATION PROCEDURE (With CONSULT-III)

#### 1.INSPECTION START

Turn ignition switch ON.

>> GO TO 2.

#### 2.CHECK SELF-DIAG RESULT

Check the screen of CONSULT-III.

Is malfunctioning part detected?

YES >> Refer to [SRC-268, "Diagnosis Procedure"](#).

NO >> **INSPECTION END.**

### DTC CONFIRMATION PROCEDURE (Without CONSULT-III)

#### NOTE:

- SRS will not enter diagnosis mode if no malfunction is detected in user mode.

#### 1.INSPECTION START

Turn ignition switch ON.

>> GO TO 2.

&lt; DTC/CIRCUIT DIAGNOSIS &gt;

**2.CHECK AIR BAG WARNING LAMP**

Check the warning lamp status.

Is malfunctioning part detected?

- YES >> Refer to [SRC-303, "DTC Index"](#).  
 NO >> **INSPECTION END.**

## Diagnosis Procedure

INFOID:000000005252975

With CONSULT-III

**WARNING:**

- Before servicing, turn ignition switch OFF, disconnect both battery terminals and wait at least 3 minutes. (To discharge backup capacitor.)
- Do not use unspecified tester or other measuring device.

## DIAGNOSTIC PROCEDURE

**1.CHECK HARNESS CONNECTOR**

Check the connection of harness connector.

Is the inspection result normal?

- YES >> GO TO 2.  
 NO >> Repair or replace harness connector.

**2.CHECK WIRING HARNESS**

Check the wiring harness externals.

Is the inspection result normal?

- YES >> GO TO 3.  
 NO >> Repair or replace wiring harness.

**3.CHECK SIDE CURTAIN AIR BAG MODULE**

1. Replace RH side curtain air bag module.
2. Check the screen of CONSULT-III.

Is the inspection result normal?

- YES >> **INSPECTION END.**  
 NO >> Check the intermittent incident. Refer to [GI-40, "Intermittent Incident"](#).

# B1148 CURTAIN MODULE RH

< DTC/CIRCUIT DIAGNOSIS >

[FOR MEXICO]

## B1148 CURTAIN MODULE RH

### Description

INFOID:000000005252976

### DTC B1148 [SHORT] CURTAIN MODULE RH

For RH side curtain air bag module, crash is judged by main "G" sensor output signal (left side: left satellite sensor, right side: right satellite sensor) and sub "G" sensor (right and left GP in center unit).

### OPERATION

In case of collision whose acceleration exceeds the specified level, the ignition materials are ignited by electric ignition system. The system burns and introduces the chemical reaction of gas generating materials to generate hot gases that flow into the air bag through a filter and expand the bag.

### STRUCTURE

RH side curtain air bag module mainly consists of air bag and inflator which inflates air bag.

### INSTALLATION

RH side curtain air bag module is installed on the roof side with fixed bolts.

### DTC Logic

INFOID:000000005252977

### DTC DETECTION LOGIC

With CONSULT-III

DTC No. Index ("SELF-DIAG [CURRENT]"), ("SELF-DIAG [PAST]" or "TROUBLE DIAG RECORD")

DTC No.	Trouble diagnosis name	DTC detecting condition	Possible cause
B1148	CURTAIN MODULE RH [SHORT]	RH side curtain air bag module circuit are shorted to each other.	<ul style="list-style-type: none"> <li>• Disconnection of wiring harness and short.</li> <li>• Internal breakdown in RH side curtain air bag module.</li> <li>• Internal breakdown in diagnosis sensor unit (ACU).</li> </ul>

### DTC CONFIRMATION PROCEDURE (With CONSULT-III)

#### 1.INSPECTION START

Turn ignition switch ON.

>> GO TO 2.

#### 2.CHECK SELF-DIAG RESULT

Check the screen of CONSULT-III.

Is malfunctioning part detected?

YES >> Refer to [SRC-270, "Diagnosis Procedure"](#).

NO >> **INSPECTION END.**

### DTC CONFIRMATION PROCEDURE (Without CONSULT-III)

#### NOTE:

- SRS will not enter diagnosis mode if no malfunction is detected in user mode.

#### 1.INSPECTION START

Turn ignition switch ON.

>> GO TO 2.

A  
B  
C  
D  
E  
F  
G  
I  
J  
K  
L  
M  
N  
O  
P

SRC

< DTC/CIRCUIT DIAGNOSIS >

---

## 2.CHECK AIR BAG WARNING LAMP

---

Check the warning lamp status.

Is malfunctioning part detected?

- YES >> Refer to [SRC-303, "DTC Index"](#).  
NO >> **INSPECTION END.**

### Diagnosis Procedure

INFOID:000000005252978

With CONSULT-III

#### **WARNING:**

- Before servicing, turn ignition switch OFF, disconnect both battery terminals and wait at least 3 minutes. (To discharge backup capacitor.)
- Do not use unspecified tester or other measuring device.

### DIAGNOSTIC PROCEDURE

---

## 1.CHECK HARNESS CONNECTOR

---

Check the connection of harness connector.

Is the inspection result normal?

- YES >> GO TO 2.  
NO >> Repair or replace harness connector.

---

## 2.CHECK WIRING HARNESS

---

Check the wiring harness externals.

Is the inspection result normal?

- YES >> GO TO 3.  
NO >> Repair or replace wiring harness.

---

## 3.CHECK SIDE CURTAIN AIR BAG MODULE

---

1. Replace RH side curtain air bag module.
2. Check the screen of CONSULT-III.

Is the inspection result normal?

- YES >> **INSPECTION END.**  
NO >> Check the intermittent incident. Refer to [GI-40, "Intermittent Incident"](#).

# B1150 CURTAIN MODULE LH

< DTC/CIRCUIT DIAGNOSIS >

[FOR MEXICO]

## B1150 CURTAIN MODULE LH

### Description

INFOID:000000005252979

### DTC B1150 [OPEN] CURTAIN MODULE LH

For LH side curtain air bag module, crash is judged by main "G" sensor output signal (left side: left satellite sensor, right side: right satellite sensor) and sub "G" sensor (right and left GP in center unit).

### OPERATION

In case of collision whose acceleration exceeds the specified level, the ignition materials are ignited by electric ignition system. The system burns and introduces the chemical reaction of gas generating materials to generate hot gases that flow into the air bag through a filter and expand the bag.

### STRUCTURE

LH side curtain air bag module mainly consists of air bag and inflator which inflates air bag.

### INSTALLATION

LH side curtain air bag module is installed on the roof side with fixed bolts.

### DTC Logic

INFOID:000000005252980

### DTC DETECTION LOGIC

With CONSULT-III

DTC No. Index ("SELF-DIAG [CURRENT]"), ("SELF-DIAG [PAST]" or "TROUBLE DIAG RECORD")

SRC

DTC No.	Trouble diagnosis name	DTC detecting condition	Possible cause
B1150	CURTAIN MODULE LH [OPEN]	LH side curtain air bag module circuit is open.	<ul style="list-style-type: none"> <li>• Disconnection of wiring harness and open.</li> <li>• Internal breakdown in LH side curtain air bag module.</li> <li>• Internal breakdown in diagnosis sensor unit (ACU).</li> </ul>

### DTC CONFIRMATION PROCEDURE (With CONSULT-III)

#### 1.INSPECTION START

Turn ignition switch ON.

>> GO TO 2.

#### 2.CHECK SELF-DIAG RESULT

Check the screen of CONSULT-III.

Is malfunctioning part detected?

YES >> Refer to [SRC-272, "Diagnosis Procedure"](#).

NO >> **INSPECTION END.**

### DTC CONFIRMATION PROCEDURE (Without CONSULT-III)

#### NOTE:

- SRS will not enter diagnosis mode if no malfunction is detected in user mode.

#### 1.INSPECTION START

Turn ignition switch ON.

>> GO TO 2.

< DTC/CIRCUIT DIAGNOSIS >

---

## 2.CHECK AIR BAG WARNING LAMP

---

Check the warning lamp status.

Is malfunctioning part detected?

YES >> Refer to [SRC-303, "DTC Index"](#).

NO >> **INSPECTION END.**

### Diagnosis Procedure

INFOID:000000005252981

With CONSULT-III

#### **WARNING:**

- Before servicing, turn ignition switch OFF, disconnect both battery terminals and wait at least 3 minutes. (To discharge backup capacitor.)
- Do not use unspecified tester or other measuring device.

### DIAGNOSTIC PROCEDURE

#### 1.CHECK HARNESS CONNECTOR

---

Check the connection of harness connector.

Is the inspection result normal?

YES >> GO TO 2.

NO >> Repair or replace harness connector.

#### 2.CHECK WIRING HARNESS

---

Check the wiring harness externals.

Is the inspection result normal?

YES >> GO TO 3.

NO >> Repair or replace wiring harness.

#### 3.CHECK SIDE CURTAIN AIR BAG MODULE

---

1. Replace LH side curtain air bag module.
2. Check the screen of CONSULT-III.

Is the inspection result normal?

YES >> **INSPECTION END.**

NO >> Check the intermittent incident. Refer to [GI-40, "Intermittent Incident"](#).



# B1151 CURTAIN MODULE LH

< DTC/CIRCUIT DIAGNOSIS >

[FOR MEXICO]

## B1151 CURTAIN MODULE LH

### Description

INFOID:000000005252982

### DTC B1151 [VB-SHORT] CURTAIN MODULE LH

For LH side curtain air bag module, crash is judged by main "G" sensor output signal (left side: left satellite sensor, right side: right satellite sensor) and sub "G" sensor (right and left GP in center unit).

### OPERATION

In case of collision whose acceleration exceeds the specified level, the ignition materials are ignited by electric ignition system. The system burns and introduces the chemical reaction of gas generating materials to generate hot gases that flow into the air bag through a filter and expand the bag.

### STRUCTURE

LH side curtain air bag module mainly consists of air bag and inflator which inflates air bag.

### INSTALLATION

LH side curtain air bag module is installed on the roof side with fixed bolts.

### DTC Logic

INFOID:000000005252983

### DTC DETECTION LOGIC

With CONSULT-III

DTC No. Index ("SELF-DIAG [CURRENT]"), ("SELF-DIAG [PAST]" or "TROUBLE DIAG RECORD")

DTC No.	Trouble diagnosis name	DTC detecting condition	Possible cause
B1151	CURTAIN MODULE LH [VB-SHORT]	LH side curtain air bag module circuit is shorted to some power supply circuit.	<ul style="list-style-type: none"><li>• Disconnection of wiring harness and short.</li><li>• Internal breakdown in LH side curtain air bag module.</li><li>• Internal breakdown in diagnosis sensor unit (ACU).</li></ul>

### DTC CONFIRMATION PROCEDURE (With CONSULT-III)

#### 1.INSPECTION START

Turn ignition switch ON.

>> GO TO 2.

#### 2.CHECK SELF-DIAG RESULT

Check the screen of CONSULT-III.

Is malfunctioning part detected?

YES >> Refer to [SRC-274, "Diagnosis Procedure"](#).

NO >> **INSPECTION END.**

### DTC CONFIRMATION PROCEDURE (Without CONSULT-III)

#### NOTE:

- SRS will not enter diagnosis mode if no malfunction is detected in user mode.

#### 1.INSPECTION START

Turn ignition switch ON.

>> GO TO 2.

A

B

C

D

E

F

G

SRC

I

J

K

L

M

N

O

P

< DTC/CIRCUIT DIAGNOSIS >

---

## 2.CHECK AIR BAG WARNING LAMP

---

Check the warning lamp status.

Is malfunctioning part detected?

YES >> Refer to [SRC-303, "DTC Index"](#).

NO >> **INSPECTION END.**

### Diagnosis Procedure

INFOID:000000005252984

With CONSULT-III

#### **WARNING:**

- Before servicing, turn ignition switch OFF, disconnect both battery terminals and wait at least 3 minutes. (To discharge backup capacitor.)
- Do not use unspecified tester or other measuring device.

### DIAGNOSTIC PROCEDURE

---

## 1.CHECK HARNESS CONNECTOR

---

Check the connection of harness connector.

Is the inspection result normal?

YES >> GO TO 2.

NO >> Repair or replace harness connector.

---

## 2.CHECK WIRING HARNESS

---

Check the wiring harness externals.

Is the inspection result normal?

YES >> GO TO 3.

NO >> Repair or replace wiring harness.

---

## 3.CHECK SIDE CURTAIN AIR BAG MODULE

---

1. Replace LH side curtain air bag module.
2. Check the screen of CONSULT-III.

Is the inspection result normal?

YES >> **INSPECTION END.**

NO >> Check the intermittent incident. Refer to [GI-40, "Intermittent Incident"](#).

# B1152 CURTAIN MODULE LH

< DTC/CIRCUIT DIAGNOSIS >

[FOR MEXICO]

## B1152 CURTAIN MODULE LH

### Description

INFOID:000000005252985

### DTC B1152 [GND-SHORT] CURTAIN MODULE LH

For LH side curtain air bag module, crash is judged by main "G" sensor output signal (left side: left satellite sensor, right side: right satellite sensor) and sub "G" sensor (right and left GP in center unit).

### OPERATION

In case of collision whose acceleration exceeds the specified level, the ignition materials are ignited by electric ignition system. The system burns and introduces the chemical reaction of gas generating materials to generate hot gases that flow into the air bag through a filter and expand the bag.

### STRUCTURE

LH side curtain air bag module mainly consists of air bag and inflator which inflates air bag.

### INSTALLATION

LH side curtain air bag module is installed on the roof side with fixed bolts.

### DTC Logic

INFOID:000000005252986

### DTC DETECTION LOGIC

With CONSULT-III

DTC No. Index ("SELF-DIAG [CURRENT]"), ("SELF-DIAG [PAST]" or "TROUBLE DIAG RECORD")

DTC No.	Trouble diagnosis name	DTC detecting condition	Possible cause
B1152	CURTAIN MODULE LH [GND-SHORT]	LH side curtain air bag module circuit is shorted to ground.	<ul style="list-style-type: none"><li>• Disconnection of wiring harness and short.</li><li>• Internal breakdown in LH side curtain airbag module.</li><li>• Internal breakdown in diagnosis sensor unit (ACU).</li></ul>

### DTC CONFIRMATION PROCEDURE (With CONSULT-III)

#### 1.INSPECTION START

Turn ignition switch ON.

>> GO TO 2.

#### 2.CHECK SELF-DIAG RESULT

Check the screen of CONSULT-III.

Is malfunctioning part detected?

YES >> Refer to [SRC-276, "Diagnosis Procedure"](#).

NO >> **INSPECTION END.**

### DTC CONFIRMATION PROCEDURE (Without CONSULT-III)

#### NOTE:

- SRS will not enter diagnosis mode if no malfunction is detected in user mode.

#### 1.INSPECTION START

Turn ignition switch ON.

>> GO TO 2.

< DTC/CIRCUIT DIAGNOSIS >

## 2.CHECK AIR BAG WARNING LAMP

Check the warning lamp status.

Is malfunctioning part detected?

YES >> Refer to [SRC-303, "DTC Index"](#).

NO >> **INSPECTION END.**

### Diagnosis Procedure

INFOID:000000005252987

With CONSULT-III

#### **WARNING:**

- Before servicing, turn ignition switch OFF, disconnect both battery terminals and wait at least 3 minutes. (To discharge backup capacitor.)
- Do not use unspecified tester or other measuring device.

### DIAGNOSTIC PROCEDURE

#### 1.CHECK HARNESS CONNECTOR

Check the connection of harness connector.

Is the inspection result normal?

YES >> GO TO 2.

NO >> Repair or replace harness connector.

#### 2.CHECK WIRING HARNESS

Check the wiring harness externals.

Is the inspection result normal?

YES >> GO TO 3.

NO >> Repair or replace wiring harness.

#### 3.CHECK SIDE CURTAIN AIR BAG MODULE

1. Replace LH side curtain air bag module.

2. Check the screen of CONSULT-III.

Is the inspection result normal?

YES >> **INSPECTION END.**

NO >> Check the intermittent incident. Refer to [GI-40, "Intermittent Incident"](#).

# B1153 CURTAIN MODULE LH

< DTC/CIRCUIT DIAGNOSIS >

[FOR MEXICO]

## B1153 CURTAIN MODULE LH

### Description

INFOID:000000005252988

### DTC B1153 [SHORT] CURTAIN MODULE LH

For LH side curtain air bag module, crash is judged by main "G" sensor output signal (left side: left satellite sensor, right side: right satellite sensor) and sub "G" sensor (right and left GP in center unit).

### OPERATION

In case of collision whose acceleration exceeds the specified level, the ignition materials are ignited by electric ignition system. The system burns and introduces the chemical reaction of gas generating materials to generate hot gases that flow into the air bag through a filter and expand the bag.

### STRUCTURE

LH side curtain air bag module mainly consists of air bag and inflator which inflates air bag.

### INSTALLATION

LH side curtain air bag module is installed on the roof side with fixed bolts.

### DTC Logic

INFOID:000000005252989

### DTC DETECTION LOGIC

With CONSULT-III

DTC No. Index ("SELF-DIAG [CURRENT]"), ("SELF-DIAG [PAST]" or "TROUBLE DIAG RECORD")

DTC No.	Trouble diagnosis name	DTC detecting condition	Possible cause
B1153	CURTAIN MODULE LH [SHORT]	LH side curtain air bag module circuit are shorted to each other.	<ul style="list-style-type: none"> <li>• Disconnection of wiring harness and short.</li> <li>• Internal breakdown in LH side curtain air bag module.</li> <li>• Internal breakdown in diagnosis sensor unit (ACU).</li> </ul>

### DTC CONFIRMATION PROCEDURE (With CONSULT-III)

#### 1.INSPECTION START

Turn ignition switch ON.

>> GO TO 2.

#### 2.CHECK SELF-DIAG RESULT

Check the screen of CONSULT-III.

Is malfunctioning part detected?

YES >> Refer to [SRC-278, "Diagnosis Procedure"](#).

NO >> **INSPECTION END.**

### DTC CONFIRMATION PROCEDURE (Without CONSULT-III)

#### NOTE:

- SRS will not enter diagnosis mode if no malfunction is detected in user mode.

#### 1.INSPECTION START

Turn ignition switch ON.

>> GO TO 2.

A  
B  
C  
D  
E  
F  
G  
I  
J  
K  
L  
M  
N  
O  
P

SRC

< DTC/CIRCUIT DIAGNOSIS >

---

## 2.CHECK AIR BAG WARNING LAMP

---

Check the warning lamp status.

Is malfunctioning part detected?

YES >> Refer to [SRC-303, "DTC Index"](#).

NO >> **INSPECTION END.**

### Diagnosis Procedure

INFOID:000000005252990

With CONSULT-III

#### **WARNING:**

- Before servicing, turn ignition switch OFF, disconnect both battery terminals and wait at least 3 minutes. (To discharge backup capacitor.)
- Do not use unspecified tester or other measuring device.

### DIAGNOSTIC PROCEDURE

#### 1.CHECK HARNESS CONNECTOR

---

Check the connection of harness connector.

Is the inspection result normal?

YES >> GO TO 2.

NO >> Repair or replace harness connector.

#### 2.CHECK WIRING HARNESS

---

Check the wiring harness externals.

Is the inspection result normal?

YES >> GO TO 3.

NO >> Repair or replace wiring harness.

#### 3.CHECK SIDE CURTAIN AIR BAG MODULE

---

1. Replace LH side curtain air bag module.

2. Check the screen of CONSULT-III.

Is the inspection result normal?

YES >> **INSPECTION END.**

NO >> Check the intermittent incident. Refer to [GI-40, "Intermittent Incident"](#).

# B1170, B1171, B1172, B1173, B1174, B1175 DIAGNOSIS SENSOR UNIT

< DTC/CIRCUIT DIAGNOSIS >

[FOR MEXICO]

## B1170, B1171, B1172, B1173, B1174, B1175 DIAGNOSIS SENSOR UNIT

### Description

INFOID:000000005252991

#### DTC B1170, B1171, B1172, B1173, B1174, B1175 DIAGNOSIS SENSOR UNIT

Detects the whole SRS electrical system and displays the malfunction either by illuminating or blinking the air bag warning lamp in the combination meter. Malfunctioning part can be detected by on board self-diagnosis system and electro-diagnosis tester CONSULT-III.

### OPERATION

It detects a shock that exceeds specified level and monitors such systems as the driver and passenger air bag, side air bag, curtain air bag, pre-tensioner seat belts operate properly.

### STRUCTURE

It contains the "G" sensors for both frontal and side collisions and spare battery function in case of main battery damage in collision.

### INSTALLATION

SRS diagnosis sensor unit is installed under the center console with fixed bolts.

### DTC Logic

INFOID:000000005252992

#### DTC DETECTION LOGIC

With CONSULT-III

DTC No. Index ("SELF-DIAG [CURRENT]"), ("SELF-DIAG [PAST]" or "TROUBLE DIAG RECORD")

DTC No.	Trouble diagnosis name	DTC detecting condition	Possible cause
B1170 B1171 B1172 B1173 B1174 B1175	CONTROL UNIT	Diagnosis sensor unit is out of order.	Internal breakdown in diagnosis sensor unit (ACU).

#### DTC CONFIRMATION PROCEDURE (With CONSULT-III)

##### 1.INSPECTION START

Turn ignition switch ON.

>> GO TO 2.

##### 2.CHECK SELF-DIAG RESULT

Check the screen of CONSULT-III.

Is malfunctioning part detected?

YES >> Refer to [SRC-280. "Diagnosis Procedure"](#).

NO >> **INSPECTION END.**

#### DTC CONFIRMATION PROCEDURE (Without CONSULT-III)

##### NOTE:

SRS will not enter diagnosis mode if no malfunction is detected in user mode.

##### 1.INSPECTION START

Turn ignition switch ON.

A  
B  
C  
D  
E  
F  
G  
I  
J  
K  
L  
M  
N  
O  
P

SRC

# B1170, B1171, B1172, B1173, B1174, B1175 DIAGNOSIS SENSOR UNIT

[FOR MEXICO]

< DTC/CIRCUIT DIAGNOSIS >

---

>> GO TO 2.

## 2.CHECK AIR BAG WARNING LAMP

---

Check the warning lamp status.

Is malfunctioning part detected?

YES >> Refer to [SRC-303, "DTC Index"](#).

NO >> **INSPECTION END.**

## Diagnosis Procedure

INFOID:000000005252993

With CONSULT-III

### **WARNING:**

- **Before servicing, turn ignition switch OFF, disconnect both battery terminals and wait at least 3 minutes. (To discharge backup capacitor.)**
- **Do not use unspecified tester or other measuring device.**

## DIAGNOSTIC PROCEDURE

### 1.CHECK HARNESS CONNECTOR

---

Check the connection of harness connector.

Is the inspection result normal?

YES >> GO TO 2.

NO >> Repair or replace harness connectors.

### 2.CHECK WIRING HARNESS

---

Check the wiring harness externals.

Is the inspection result normal?

YES >> GO TO 3.

NO >> Repair or replace wiring harness.

### 3.CHECK DIAGNOSIS SENSOR UNIT

---

1. Replace diagnosis sensor unit (ACU).

2. Check the screen of CONSULT-III.

Is the inspection result normal?

YES >> **INSPECTION END.**

NO >> Check the intermittent incident. Refer to [GI-40, "Intermittent Incident"](#).



# B1177 PRE-TEN2 FRONT RH

< DTC/CIRCUIT DIAGNOSIS >

[FOR MEXICO]

## B1177 PRE-TEN2 FRONT RH

### Description

INFOID:000000005252994

### DTC B1177 [OPEN] PRE-TEN2 FRONT RH

For front RH seat belt pre-tensioner 2, crash is judged by main "G" sensor output signal and sub "G" sensor in front direction.

### OPERATION

In the case of a frontal collision that exceeds specified impact level, the diagnosis sensor unit detects the deceleration caused by collision. If restrains the passenger with seat belt easing the stress on passengers chest with load limiter.

### STRUCTURE

The restraint system for front seat occupant consists of the pre-tensioner mechanism and load limiter mechanism.

### INSTALLATION

Front RH seat belt pre-tensioner 2 is installed on the underside of center pillar with fixed nuts.

### DTC Logic

INFOID:000000005252995

### DTC DETECTION LOGIC

With CONSULT-III

DTC No. Index ("SELF-DIAG [CURRENT]"), ("SELF-DIAG [PAST]" or "TROUBLE DIAG RECORD")

DTC No.	Trouble diagnosis name	DTC detecting condition	Possible cause
B1177	PRE-TEN2 FRONT RH [OPEN]	Front RH seat belt pre-tensioner 2 circuit is open.	<ul style="list-style-type: none"> <li>Disconnection of wiring harness and open.</li> <li>Internal breakdown in front RH seat belt pre-tensioner 2.</li> <li>Internal breakdown in diagnosis sensor unit (ACU).</li> </ul>

### DTC CONFIRMATION PROCEDURE (With CONSULT-III)

#### 1.INSPECTION START

Turn ignition switch ON.

>> GO TO 2.

#### 2.CHECK SELF-DIAG RESULT

Check the screen of CONSULT-III.

Is malfunctioning part detected?

- YES >> Refer to [SRC-282. "Diagnosis Procedure"](#).
- NO >> **INSPECTION END.**

### DTC CONFIRMATION PROCEDURE (Without CONSULT-III)

#### NOTE:

- SRS will not enter diagnosis mode if no malfunction is detected in user mode.

#### 1.INSPECTION START

Turn ignition switch ON.

A  
B  
C  
D  
E  
F  
G  
I  
J  
K  
L  
M  
N  
O  
P

SRC

< DTC/CIRCUIT DIAGNOSIS >

---

>> GO TO 2.

## 2.CHECK AIR BAG WARNING LAMP

---

Check the warning lamp status.

Is malfunctioning part detected?

YES >> Refer to [SRC-303, "DTC Index"](#).

NO >> **INSPECTION END.**

## Diagnosis Procedure

INFOID:000000005252996

With CONSULT-III

### **WARNING:**

- **Before servicing, turn ignition switch OFF, disconnect both battery terminals and wait at least 3 minutes. (To discharge backup capacitor.)**
- **Do not use unspecified tester or other measuring device.**

## DIAGNOSTIC PROCEDURE

### 1.CHECK HARNESS CONNECTOR

---

Check the connection of harness connector.

Is the inspection result normal?

YES >> GO TO 2.

NO >> Repair or replace harness connector.

### 2.CHECK WIRING HARNESS

---

Check the wiring harness externals.

Is the inspection result normal?

YES >> GO TO 3.

NO >> Repair or replace wiring harness.

### 3.CHECK FRONT SEAT BELT PRE-TENSIONER 2

---

1. Replace front RH seat belt pre-tensioner 2.

2. Check the screen of CONSULT-III.

Is the inspection result normal?

YES >> **INSPECTION END.**

NO >> Check the intermittent incident. Refer to [GI-40, "Intermittent Incident"](#).

# B1178 PRE-TEN2 FRONT RH

< DTC/CIRCUIT DIAGNOSIS >

[FOR MEXICO]

## B1178 PRE-TEN2 FRONT RH

### Description

INFOID:000000005252997

### DTC B1178 [VB-SHORT] PRE-TEN2 FRONT RH

For front RH seat belt pre-tensioner 2, crash is judged by main "G" sensor output signal and sub "G" sensor in front direction.

### OPERATION

In the case of a frontal collision that exceeds specified impact level, the diagnosis sensor unit detects the deceleration caused by collision. If restrains the passenger with seat belt easing the stress on passengers chest with load limiter.

### STRUCTURE

The restraint system for front seat occupant consists of the pre-tensioner mechanism and load limiter mechanism.

### INSTALLATION

Front RH seat belt pre-tensioner 2 is installed on the underside of center pillar with fixed nuts.

### DTC Logic

INFOID:000000005252998

### DTC DETECTION LOGIC

With CONSULT-III

DTC No. Index ("SELF-DIAG [CURRENT]"), ("SELF-DIAG [PAST]" or "TROUBLE DIAG RECORD")

DTC No.	Trouble diagnosis name	DTC detecting condition	Possible cause
B1178	PRE-TEN2 FRONT RH [VB-SHORT]	Front RH seat belt pre-tensioner 2 circuit is shorted to some power supply circuit.	<ul style="list-style-type: none"> <li>Disconnection of wiring harness and short.</li> <li>Internal breakdown in front RH seat belt pre-tensioner 2.</li> <li>Internal breakdown in diagnosis sensor unit (ACU).</li> </ul>

### DTC CONFIRMATION PROCEDURE (With CONSULT-III)

#### 1.INSPECTION START

Turn ignition switch ON.

>> GO TO 2.

#### 2.CHECK SELF-DIAG RESULT

Check the screen of CONSULT-III.

Is malfunctioning part detected?

- YES >> Refer to [SRC-284, "Diagnosis Procedure"](#).
- NO >> **INSPECTION END.**

### DTC CONFIRMATION PROCEDURE (Without CONSULT-III)

#### NOTE:

- SRS will not enter diagnosis mode if no malfunction is detected in user mode.

#### 1.INSPECTION START

Turn ignition switch ON.

A  
B  
C  
D  
E  
F  
G  
I  
J  
K  
L  
M  
N  
O  
P

SRC

< DTC/CIRCUIT DIAGNOSIS >

---

>> GO TO 2.

## 2.CHECK AIR BAG WARNING LAMP

---

Check the warning lamp status.

Is malfunctioning part detected?

YES >> Refer to [SRC-303, "DTC Index"](#).

NO >> **INSPECTION END.**

## Diagnosis Procedure

INFOID:000000005252999

With CONSULT-III

### **WARNING:**

- **Before servicing, turn ignition switch OFF, disconnect both battery terminals and wait at least 3 minutes. (To discharge backup capacitor.)**
- **Do not use unspecified tester or other measuring device.**

## DIAGNOSTIC PROCEDURE

### 1.CHECK HARNESS CONNECTOR

---

Check the connection of harness connector.

Is the inspection result normal?

YES >> GO TO 2.

NO >> Repair or replace harness connector.

### 2.CHECK WIRING HARNESS

---

Check the wiring harness externals.

Is the inspection result normal?

YES >> GO TO 3.

NO >> Repair or replace wiring harness.

### 3.CHECK FRONT SEAT BELT PRE-TENSIONER 2

---

1. Replace front RH seat belt pre-tensioner 2.

2. Check the screen of CONSULT-III.

Is the inspection result normal?

YES >> **INSPECTION END.**

NO >> Check the intermittent incident. Refer to [GI-40, "Intermittent Incident"](#).

# B1179 PRE-TEN2 FRONT RH

< DTC/CIRCUIT DIAGNOSIS >

[FOR MEXICO]

## B1179 PRE-TEN2 FRONT RH

### Description

INFOID:000000005253000

### DTC B1179 [GND-SHORT] PRE-TEN2 FRONT RH

For front RH seat belt pre-tensioner 2, crash is judged by main "G" sensor output signal and sub "G" sensor in front direction.

### OPERATION

In the case of a frontal collision that exceeds specified impact level, the diagnosis sensor unit detects the deceleration caused by collision. If restrains the passenger with seat belt easing the stress on passengers chest with load limiter.

### STRUCTURE

The restraint system for front seat occupant consists of the pre-tensioner mechanism and load limiter mechanism.

### INSTALLATION

Front RH seat belt pre-tensioner 2 is installed on the underside of center pillar with fixed nuts.

### DTC Logic

INFOID:000000005253001

### DTC DETECTION LOGIC

With CONSULT-III

DTC No. Index ("SELF-DIAG [CURRENT]"), ("SELF-DIAG [PAST]" or "TROUBLE DIAG RECORD")

DTC No.	Trouble diagnosis name	DTC detecting condition	Possible cause
B1179	PRE-TEN2 FRONT RH [GND-SHORT]	Front RH seat belt pre-tensioner 2 circuit is shorted to ground.	<ul style="list-style-type: none"> <li>Disconnection of wiring harness and short.</li> <li>Internal breakdown in front RH seat belt pre-tensioner 2.</li> <li>Internal breakdown in diagnosis sensor unit (ACU).</li> </ul>

### DTC CONFIRMATION PROCEDURE (With CONSULT-III)

#### 1.INSPECTION START

Turn ignition switch ON.

>> GO TO 2.

#### 2.CHECK SELF-DIAG RESULT

Check the screen of CONSULT-III.

Is malfunctioning part detected?

- YES >> Refer to [SRC-286. "Diagnosis Procedure"](#).
- NO >> **INSPECTION END.**

### DTC CONFIRMATION PROCEDURE (Without CONSULT-III)

#### NOTE:

- SRS will not enter diagnosis mode if no malfunction is detected in user mode.

#### 1.INSPECTION START

Turn ignition switch ON.

A  
B  
C  
D  
E  
F  
G  
I  
J  
K  
L  
M  
N  
O  
P

SRC

&lt; DTC/CIRCUIT DIAGNOSIS &gt;

&gt;&gt; GO TO 2.

**2.CHECK AIR BAG WARNING LAMP**

Check the warning lamp status.

Is malfunctioning part detected?YES >> Refer to [SRC-303, "DTC Index"](#).NO >> **INSPECTION END.**

## Diagnosis Procedure

INFOID:000000005253002

With CONSULT-III

**WARNING:**

- **Before servicing, turn ignition switch OFF, disconnect both battery terminals and wait at least 3 minutes. (To discharge backup capacitor.)**
- **Do not use unspecified tester or other measuring device.**

## DIAGNOSTIC PROCEDURE

**1.CHECK HARNESS CONNECTOR**

Check the connection of harness connector.

Is the inspection result normal?

YES &gt;&gt; GO TO 2.

NO &gt;&gt; Repair or replace harness connector.

**2.CHECK WIRING HARNESS**

Check the wiring harness externals.

Is the inspection result normal?

YES &gt;&gt; GO TO 3.

NO &gt;&gt; Repair or replace wiring harness.

**3.CHECK FRONT SEAT BELT PRE-TENSIONER 2**

1. Replace front RH seat belt pre-tensioner 2.

2. Check the screen of CONSULT-III.

Is the inspection result normal?YES >> **INSPECTION END.**NO >> Check the intermittent incident. Refer to [GI-40, "Intermittent Incident"](#).

# B1180 PRE-TEN2 FRONT RH

< DTC/CIRCUIT DIAGNOSIS >

[FOR MEXICO]

## B1180 PRE-TEN2 FRONT RH

### Description

INFOID:000000005253003

#### DTC B1180 [SHORT] PRE-TEN2 FRONT RH

For front RH seat belt pre-tensioner 2, crash is judged by main "G" sensor output signal and sub "G" sensor in front direction.

### OPERATION

In the case of a frontal collision that exceeds specified impact level, the diagnosis sensor unit detects the deceleration caused by collision. If restrains the passenger with seat belt easing the stress on passengers chest with load limiter.

### STRUCTURE

The restraint system for front seat occupant consists of the pre-tensioner mechanism and load limiter mechanism.

### INSTALLATION

Front RH seat belt pre-tensioner 2 is installed on the underside of center pillar with fixed nuts.

### DTC Logic

INFOID:000000005253004

#### DTC DETECTION LOGIC

With CONSULT-III

DTC No. Index ("SELF-DIAG [CURRENT]"), ("SELF-DIAG [PAST]" or "TROUBLE DIAG RECORD")

DTC No.	Trouble diagnosis name	DTC detecting condition	Possible cause
B1180	PRE-TEN2 FRONT RH [SHORT]	Front RH seat belt pre-tensioner 2 circuit are shorted to each other.	<ul style="list-style-type: none"> <li>Disconnection of wiring harness and short.</li> <li>Internal breakdown in front RH seat belt pre-tensioner 2.</li> <li>Internal breakdown in diagnosis sensor unit (ACU).</li> </ul>

#### DTC CONFIRMATION PROCEDURE (With CONSULT-III)

##### 1.INSPECTION START

Turn ignition switch ON.

>> GO TO 2.

##### 2.CHECK SELF-DIAG RESULT

Check the screen of CONSULT-III.

Is malfunctioning part detected?

YES >> Refer to [SRC-288, "Diagnosis Procedure"](#).

NO >> **INSPECTION END.**

#### DTC CONFIRMATION PROCEDURE (Without CONSULT-III)

##### NOTE:

- SRS will not enter diagnosis mode if no malfunction is detected in user mode.

##### 1.INSPECTION START

Turn ignition switch ON.

A  
B  
C  
D  
E  
F  
G  
I  
J  
K  
L  
M  
N  
O  
P

SRC

< DTC/CIRCUIT DIAGNOSIS >

---

>> GO TO 2.

## 2.CHECK AIR BAG WARNING LAMP

---

Check the warning lamp status.

Is malfunctioning part detected?

YES >> Refer to [SRC-303, "DTC Index"](#).

NO >> **INSPECTION END.**

## Diagnosis Procedure

INFOID:000000005253005

With CONSULT-III

### **WARNING:**

- **Before servicing, turn ignition switch OFF, disconnect both battery terminals and wait at least 3 minutes. (To discharge backup capacitor.)**
- **Do not use unspecified tester or other measuring device.**

## DIAGNOSTIC PROCEDURE

### 1.CHECK HARNESS CONNECTOR

---

Check the connection of harness connector.

Is the inspectiion result normal?

YES >> GO TO 2.

NO >> Repair or replace harness connector.

### 2.CHECK WIRING HARNESS

---

Check the wiring harness externals.

Is the inspection result normal?

YES >> GO TO 3.

NO >> Repair or replace wiring harness.

### 3.CHECK FRONT SEAT BELT PRE-TENSIONER 2

---

1. Replace front RH seat belt pre-tensioner 2.

2. Check the screen of CONSULT-III.

Is the inspection result normal?

YES >> **INSPECTION END.**

NO >> Check the intermittent incident. Refer to [GI-40, "Intermittent Incident"](#).



# B1182 PRE-TEN2 FRONT LH

< DTC/CIRCUIT DIAGNOSIS >

[FOR MEXICO]

## B1182 PRE-TEN2 FRONT LH

### Description

INFOID:000000005253006

### DTC B1182 [OPEN] PRE-TEN2 FRONT LH

For front LH seat belt pre-tensioner 2, crash is judged by main "G" sensor output signal and sub "G" sensor in front direction.

### OPERATION

In the case of a frontal collision that exceeds specified impact level, the diagnosis sensor unit detects the deceleration caused by collision. If restrains the passenger with seat belt easing the stress on passengers chest with load limiter.

### STRUCTURE

The restraint system for front seat occupant consists of the pre-tensioner mechanism and load limiter mechanism.

### INSTALLATION

Front LH seat belt pre-tensioner 2 is installed on the underside of center pillar with fixed nuts.

### DTC Logic

INFOID:000000005253007

### DTC DETECTION LOGIC

With CONSULT-III

DTC No. Index ("SELF-DIAG [CURRENT]"), ("SELF-DIAG [PAST]" or "TROUBLE DIAG RECORD")

DTC No.	Trouble diagnosis name	DTC detecting condition	Possible cause
B1182	PRE-TEN2 FRONT LH [OPEN]	Front LH seat belt pre-tensioner 2 circuit is open.	<ul style="list-style-type: none"> <li>Disconnection of wiring harness and open.</li> <li>Internal breakdown in front LH seat belt pre-tensioner 2.</li> <li>Internal breakdown in diagnosis sensor unit (ACU).</li> </ul>

### DTC CONFIRMATION PROCEDURE (With CONSULT-III)

#### 1.INSPECTION START

Turn ignition switch ON.

>> GO TO 2.

#### 2.CHECK SELF-DIAG RESULT

Check the screen of CONSULT-III.

Is malfunctioning part detected?

- YES >> Refer to [SRC-290. "Diagnosis Procedure"](#).
- NO >> **INSPECTION END.**

### DTC CONFIRMATION PROCEDURE (Without CONSULT-III)

#### NOTE:

- SRS will not enter diagnosis mode if no malfunction is detected in user mode.

#### 1.INSPECTION START

Turn ignition switch ON.

A  
B  
C  
D  
E  
F  
G  
I  
J  
K  
L  
M  
N  
O  
P

SRC

< DTC/CIRCUIT DIAGNOSIS >

---

>> GO TO 2.

## 2.CHECK AIR BAG WARNING LAMP

---

Check the warning lamp status.

Is malfunctioning part detected?

YES >> Refer to [SRC-303, "DTC Index"](#).

NO >> **INSPECTION END.**

## Diagnosis Procedure

INFOID:000000005253008

With CONSULT-III

### **WARNING:**

- **Before servicing, turn ignition switch OFF, disconnect both battery terminals and wait at least 3 minutes. (To discharge backup capacitor.)**
- **Do not use unspecified tester or other measuring device.**

## DIAGNOSTIC PROCEDURE

### 1.CHECK HARNESS CONNECTOR

---

Check the connection of harness connector.

Is the inspection result normal?

YES >> GO TO 2.

NO >> Repair or replace harness connector.

### 2.CHECK WIRING HARNESS

---

Check the wiring harness externals.

Is the inspection result normal?

YES >> GO TO 3.

NO >> Replace wiring harness.

### 3.CHECK FRONT SEAT BELT PRE-TENSIONER 2

---

1. Replace front LH seat belt pre-tensioner 2.

2. Check the screen of CONSULT-III.

Is the inspection result normal?

YES >> **INSPECTION END.**

NO >> Check the intermittent incident. Refer to [GI-40, "Intermittent Incident"](#).

# B1183 PRE-TEN2 FRONT LH

< DTC/CIRCUIT DIAGNOSIS >

[FOR MEXICO]

## B1183 PRE-TEN2 FRONT LH

### Description

INFOID:000000005253009

### DTC B1183 [VB-SHORT] PRE-TEN2 FRONT LH

For front LH seat belt pre-tensioner 2, crash is judged by main "G" sensor output signal and sub "G" sensor in front direction.

### OPERATION

In the case of a frontal collision that exceeds specified impact level, the diagnosis sensor unit detects the deceleration caused by collision. If restrains the passenger with seat belt easing the stress on passengers chest with load limiter.

### STRUCTURE

The restraint system for front seat occupant consists of the pre-tensioner mechanism and load limiter mechanism.

### INSTALLATION

Front LH seat belt pre-tensioner 2 is installed on the underside of center pillar with fixed nuts.

### DTC Logic

INFOID:000000005253010

### DTC DETECTION LOGIC

With CONSULT-III

DTC No. Index ("SELF-DIAG [CURRENT]"), ("SELF-DIAG [PAST]" or "TROUBLE DIAG RECORD")

DTC No.	Trouble diagnosis name	DTC detecting condition	Possible cause
B1183	PRE-TEN2 FRONT LH [VB-SHORT]	Front LH seat belt pre-tensioner 2 circuit is shorted to some power supply circuit.	<ul style="list-style-type: none"><li>• Disconnection of wiring harness and short.</li><li>• Internal breakdown in front LH seat belt pre-tensioner 2.</li><li>• Internal breakdown in diagnosis sensor unit (ACU).</li></ul>

### DTC CONFIRMATION PROCEDURE (With CONSULT-III)

#### 1.INSPECTION START

Turn ignition switch ON.

>> GO TO 2.

#### 2.CHECK SELF-DIAG RESULT

Check the screen of CONSULT-III.

Is malfunctioning part detected?

- YES >> Refer to [SRC-292. "Diagnosis Procedure"](#).  
NO >> **INSPECTION END.**

### DTC CONFIRMATION PROCEDURE (Without CONSULT-III)

#### NOTE:

- SRS will not enter diagnosis mode if no malfunction is detected in user mode.

#### 1.INSPECTION START

Turn ignition switch ON.

A  
B  
C  
D  
E  
F  
G  
I  
J  
K  
L  
M  
N  
O  
P

SRC

&lt; DTC/CIRCUIT DIAGNOSIS &gt;

&gt;&gt; GO TO 2.

**2.CHECK AIR BAG WARNING LAMP**

Check the warning lamp status.

Is malfunctioning part detected?YES >> Refer to [SRC-303, "DTC Index"](#).NO >> **INSPECTION END.**

## Diagnosis Procedure

INFOID:000000005253011

With CONSULT-III

**WARNING:**

- **Before servicing, turn ignition switch OFF, disconnect both battery terminals and wait at least 3 minutes. (To discharge backup capacitor.)**
- **Do not use unspecified tester or other measuring device.**

## DIAGNOSTIC PROCEDURE

**1.CHECK HARNESS CONNECTOR**

Check the connection of harness connector.

Is the inspection result normal?

YES &gt;&gt; GO TO 2.

NO &gt;&gt; Repair or replace harness connector.

**2.CHECK WIRING HARNESS**

Check the wiring harness externals.

Is the inspection result normal?

YES &gt;&gt; GO TO 3.

NO &gt;&gt; Repair or replace wiring harness.

**3.CHECK FRONT SEAT BELT PRE-TENSIONER 2**

1. Replace front LH seat belt pre-tensioner 2.

2. Check the screen of CONSULT-III.

Is the inspection result normal?YES >> **INSPECTION END.**NO >> Check the intermittent incident. Refer to [GI-40, "Intermittent Incident"](#).

# B1184 PRE-TEN2 FRONT LH

< DTC/CIRCUIT DIAGNOSIS >

[FOR MEXICO]

## B1184 PRE-TEN2 FRONT LH

### Description

INFOID:000000005253012

### DTC B1184 [GND-SHORT] PRE-TEN2 FRONT LH

For front LH seat belt pre-tensioner 2, crash is judged by main "G" sensor output signal and sub "G" sensor in front direction.

### OPERATION

In the case of a frontal collision that exceeds specified impact level, the diagnosis sensor unit detects the deceleration caused by collision. If restrains the passenger with seat belt easing the stress on passengers chest with load limiter.

### STRUCTURE

The restraint system for front seat occupant consists of the pre-tensioner mechanism and load limiter mechanism.

### INSTALLATION

Front LH seat belt pre-tensioner 2 is installed on the underside of center pillar with fixed nuts.

### DTC Logic

INFOID:000000005253013

### DTC DETECTION LOGIC

With CONSULT-III

DTC No. Index ("SELF-DIAG [CURRENT]"), ("SELF-DIAG [PAST]" or "TROUBLE DIAG RECORD")

DTC No.	Trouble diagnosis name	DTC detecting condition	Possible cause
B1184	PRE-TEN2 FRONT LH [GND-SHORT]	Front LH seat belt pre-tensioner 2 circuit is shorted to ground.	<ul style="list-style-type: none"><li>• Disconnection of wiring harness and short.</li><li>• Internal breakdown in front LH seat belt pre-tensioner 2.</li><li>• Internal breakdown in diagnosis sensor unit (ACU).</li></ul>

### DTC CONFIRMATION PROCEDURE (With CONSULT-III)

#### 1.INSPECTION START

Turn ignition switch ON.

>> GO TO 2.

#### 2.CHECK SELF-DIAG RESULT

Check the screen of CONSULT-III.

Is malfunctioning part detected?

- YES >> Refer to [SRC-294, "Diagnosis Procedure"](#).  
NO >> **INSPECTION END.**

### DTC CONFIRMATION PROCEDURE (Without CONSULT-III)

#### NOTE:

- SRS will not enter diagnosis mode if no malfunction is detected in user mode.

#### 1.INSPECTION START

Turn ignition switch ON.

A  
B  
C  
D  
E  
F  
G  
I  
J  
K  
L  
M  
N  
O  
P

SRC

&lt; DTC/CIRCUIT DIAGNOSIS &gt;

&gt;&gt; GO TO 2.

**2.CHECK AIR BAG WARNING LAMP**

Check the warning lamp status.

Is malfunctioning part detected?YES >> Refer to [SRC-303, "DTC Index"](#).NO >> **INSPECTION END.**

## Diagnosis Procedure

INFOID:000000005253014

With CONSULT-III

**WARNING:**

- **Before servicing, turn ignition switch OFF, disconnect both battery terminals and wait at least 3 minutes. (To discharge backup capacitor.)**
- **Do not use unspecified tester or other measuring device.**

## DIAGNOSTIC PROCEDURE

**1.CHECK HARNESS CONNECTOR**

Check the connection of harness connector.

Is the inspection result normal?

YES &gt;&gt; GO TO 2.

NO &gt;&gt; Repair or replace harness connector.

**2.CHECK WIRING HARNESS**

Check the wiring harness externals.

Is the inspection result normal?

YES &gt;&gt; GO TO 3.

NO &gt;&gt; Replace wiring harness.

**3.CHECK FRONT SEAT BELT PRE-TENSIONER 2**

1. Replace front LH seat belt pre-tensioner 2.

2. Check the screen of CONSULT-III.

Is the inspection result normal?YES >> **INSPECTION END.**NO >> Check the intermittent incident. Refer to [GI-40, "Intermittent Incident"](#).

# B1185 PRE-TEN2 FRONT LH

< DTC/CIRCUIT DIAGNOSIS >

[FOR MEXICO]

## B1185 PRE-TEN2 FRONT LH

### Description

INFOID:000000005253015

### DTC B1185 [SHORT] PRE-TEN2 FRONT LH

For front LH seat belt pre-tensioner 2, crash is judged by main "G" sensor output signal and sub "G" sensor in front direction.

### OPERATION

In the case of a frontal collision that exceeds specified impact level, the diagnosis sensor unit detects the deceleration caused by collision. If restrains the passenger with seat belt easing the stress on passengers chest with load limiter.

### STRUCTURE

The restraint system for front seat occupant consists of the pre-tensioner mechanism and load limiter mechanism.

### INSTALLATION

Front LH seat belt pre-tensioner 2 is installed on the underside of center pillar with fixed nuts.

### DTC Logic

INFOID:000000005253016

### DTC DETECTION LOGIC

With CONSULT-III

DTC No. Index ("SELF-DIAG [CURRENT]"), ("SELF-DIAG [PAST]" or "TROUBLE DIAG RECORD")

DTC No.	Trouble diagnosis name	DTC detecting condition	Possible cause
B1185	PRE-TEN2 FRONT LH [SHORT]	Front LH seat belt pre-tensioner 2 circuit are shorted to each other.	<ul style="list-style-type: none"> <li>Disconnection of wiring harness and short.</li> <li>Internal breakdown in front LH seat belt pre-tensioner 2.</li> <li>Internal breakdown in diagnosis sensor unit (ACU).</li> </ul>

### DTC CONFIRMATION PROCEDURE (With CONSULT-III)

#### 1.INSPECTION START

Turn ignition switch ON.

>> GO TO 2.

#### 2.CHECK SELF-DIAG RESULT

Check the screen of CONSULT-III.

Is malfunctioning part detected?

YES >> Refer to [SRC-296. "Diagnosis Procedure"](#).

NO >> **INSPECTION END.**

### DTC CONFIRMATION PROCEDURE (Without CONSULT-III)

#### NOTE:

- SRS will not enter diagnosis mode if no malfunction is detected in user mode.

#### 1.INSPECTION START

Turn ignition switch ON.

A  
B  
C  
D  
E  
F  
G  
I  
J  
K  
L  
M  
N  
O  
P

SRC

< DTC/CIRCUIT DIAGNOSIS >

---

>> GO TO 2.

## 2.CHECK AIR BAG WARNING LAMP

---

Check the warning lamp status.

Is malfunctioning part detected?

YES >> Refer to [SRC-303, "DTC Index"](#).

NO >> **INSPECTION END.**

## Diagnosis Procedure

INFOID:000000005253017

With CONSULT-III

### **WARNING:**

- **Before servicing, turn ignition switch OFF, disconnect both battery terminals and wait at least 3 minutes. (To discharge backup capacitor.)**
- **Do not use unspecified tester or other measuring device.**

## DIAGNOSTIC PROCEDURE

### 1.CHECK HARNESS CONNECTOR

---

Check the connection of harness connector.

Is the inspection result normal?

YES >> GO TO 2.

NO >> Repair or replace harness connector.

### 2.CHECK WIRING HARNESS

---

Check the wiring harness externals.

Is the inspection result normal?

YES >> GO TO 3.

NO >> Replace wiring harness.

### 3.CHECK FRONT SEAT BELT PRE-TENSIONER 2

---

1. Replace front LH seat belt pre-tensioner 2.

2. Check the screen of CONSULT-III.

Is the inspection result normal?

YES >> **INSPECTION END.**

NO >> Check the intermittent incident. Refer to [GI-40, "Intermittent Incident"](#).



# B1202, B1203, B1204, B1205, B1206, B1207 DIAGNOSIS SENSOR UNIT

< DTC/CIRCUIT DIAGNOSIS >

[FOR MEXICO]

## B1202, B1203, B1204, B1205, B1206, B1207 DIAGNOSIS SENSOR UNIT

### Description

INFOID:000000005253018

#### DTC B1202, B1203, B1204, B1205, B1206, B1207 DIAGNOSIS SENSOR UNIT

Detects the whole SRS electrical system and displays the malfunction either by illuminating or blinking the air bag warning lamp in the combination meter. Malfunctioning part can be detected by on board self-diagnosis system and electro-diagnosis tester CONSULT-III.

#### OPERATION

It detects a shock that exceeds specified level and monitors such systems as the driver and passenger air bag, side air bag, curtain air bag, pre-tensioner seat belts operate properly.

#### STRUCTURE

It contains the "G" sensors for both frontal and side collisions and spare battery function in case of main battery damage in collision.

#### INSTALLATION

SRS diagnosis sensor unit is installed under the center console with fixed bolts.

### DTC Logic

INFOID:000000005253019

#### DTC DETECTION LOGIC

With CONSULT-III

DTC No. Index ("SELF-DIAG [CURRENT]"), ("SELF-DIAG [PAST]" or "TROUBLE DIAG RECORD")

DTC No.	Trouble diagnosis name	DTC detecting condition	Possible cause
B1202 B1203 B1204 B1205 B1206 B1207	CONTROL UNIT	Diagnosis sensor unit is out of order.	Internal breakdown in diagnosis sensor unit (ACU).

#### DTC CONFIRMATION PROCEDURE (With CONSULT-III)

##### 1.INSPECTION START

Turn ignition switch ON.

>> GO TO 2.

##### 2.CHECK SELF-DIAG RESULT

Check the screen of CONSULT-III.

Is malfunctioning part detected?

YES >> Refer to [SRC-298. "Diagnosis Procedure"](#).

NO >> **INSPECTION END.**

#### DTC CONFIRMATION PROCEDURE (Without CONSULT-III)

##### NOTE:

- SRS will not enter diagnosis mode if no malfunction is detected in user mode.

##### 1.INSPECTION START

Turn ignition switch ON.

A  
B  
C  
D  
E  
F  
G  
I  
J  
K  
L  
M  
N  
O  
P

SRC

# B1202, B1203, B1204, B1205, B1206, B1207 DIAGNOSIS SENSOR UNIT

< DTC/CIRCUIT DIAGNOSIS >

[FOR MEXICO]

>> GO TO 2.

## 2.CHECK AIR BAG WARNING LAMP

Check the warning lamp status.

Is malfunctioning part detected?

YES >> Refer to [SRC-303, "DTC Index"](#).

NO >> **INSPECTION END.**

## Diagnosis Procedure

INFOID:000000005253020

With CONSULT-III

### **WARNING:**

- **Before servicing, turn ignition switch OFF, disconnect both battery terminals and wait at least 3 minutes. (To discharge backup capacitor.)**
- **Do not use unspecified tester or other measuring device.**

## DIAGNOSTIC PROCEDURE

### 1.CHECK HARNESS CONNECTOR

Check the connection of harness connector.

Is the inspection result normal?

YES >> GO TO 2.

NO >> Repair or replace harness connectors.

### 2.CHECK WIRING HARNESS

Check the wiring harness externals.

Is the inspection result normal?

YES >> GO TO 3.

NO >> Repair or replace wiring harness.

### 3.CHECK DIAGNOSIS SENSOR UNIT

1. Replace diagnosis sensor unit (ACU).

2. Check the screen of CONSULT-III.

Is the inspection result normal?

YES >> **INSPECTION END.**

NO >> Check the intermittent incident. Refer to [GI-40, "Intermittent Incident"](#).

# B1209 FRONTAL COLLISION DETECTION

< DTC/CIRCUIT DIAGNOSIS >

[FOR MEXICO]

## B1209 FRONTAL COLLISION DETECTION

### Description

INFOID:000000005253021

### DTC B1209 FRONTAL COLLISION DETECTION

Detects component damage resulting from a front collision, blinks or illuminates the air bag warning lamp to inform the driver. Malfunctioning part can be detected by the CONSULT-III.

### OPERATION

The air bag and seat belt pre-tensioners for driver and front seat passenger are operated by the decision of the diagnosis sensor unit (ACU) out signal transmitted because of the frontal collision.

### STRUCTURE

It consists of crash zone sensor, diagnosis sensor unit (ACU), air bags and seat belt pre-tensioners for driver and front passenger.

### INSTALLATION

Refer to [SR-36, "Removal and Installation"](#), [SR-41, "Removal and Installation"](#), [SB-7, "SEAT BELT RETRAC-TOR : Removal and Installation"](#), [SR-39, "Removal and Installation"](#), [SR-49, "Removal and Installation"](#).

### DTC Logic

INFOID:000000005253022

### DTC DETECTION LOGIC

With CONSULT-III

DTC No. Index ("SELF-DIAG [CURRENT]"), ("SELF-DIAG [PAST]" or "TROUBLE DIAG RECORD")

DTC No.	Trouble diagnosis name	DTC detecting condition	Possible cause
B1209	FRONTAL COLLISION DETECTION	Front seat belt pre-tensioner, front air bag is deployed.	—

### DTC CONFIRMATION PROCEDURE (With CONSULT-III)

#### 1.INSPECTION START

Turn ignition switch ON.

>> GO TO 2.

#### 2.CHECK SELF-DIAG RESULT

Check the screen of CONSULT-III.

Is malfunctioning part detected?

- YES >> Refer to [SRC-299, "Diagnosis Procedure"](#).
- NO >> **INSPECTION END.**

### Diagnosis Procedure

INFOID:000000005511350

#### **WARNING:**

- Before servicing, turn ignition switch OFF, disconnect battery negative terminal, and wait at least 3 minutes or more. (To discharge backup capacitor.)
- Never use unspecified tester or other measuring device.

#### 1.PERFORM COLLISION DIAGNOSIS

Perform collision diagnosis.Refer to [SR-30, "FOR FRONTAL COLLISION : When SRS is activated in a collision"](#) or [SR-31, "FOR FRONTAL COLLISION : When SRS is not activated in a collision"](#).

Is collision diagnosis complete?

- YES >> GO TO 2.

## B1209 FRONTAL COLLISION DETECTION

[FOR MEXICO]

< DTC/CIRCUIT DIAGNOSIS >

---

NO >> INSPECTION END

### 2.FINAL INSPECTION

---

Perform "AIR BAG" Self Diagnostic Result.

Is the inspection result normal?

YES >> INSPECTION END

NO >> Perform diagnosis of applicable DTC.Refer to [SRC-303, "DTC Index"](#).

# B1210 SIDE COLLISION DETECTION

< DTC/CIRCUIT DIAGNOSIS >

[FOR MEXICO]

## B1210 SIDE COLLISION DETECTION

### Description

INFOID:000000005253024

### DTC B1210 SIDE COLLISION DETECTION

Detects component damage resulting from a side collision, brinks or illuminates the air bag warning lamp to inform the driver. Malfunctioning part can be detected by the CONSULT-III.

### OPERATION

The side air bag and curtain air bag are operated by the decision of the diagnosis sensor unit (ACU) signal of the side collision.

### STRUCTURE

It consists of satellite sensor, diagnosis sensor unit (ACU), front side air bag and side curtain air bag.

### INSTALLATION

Refer to [SE-28. "Removal and Installation"](#), [SR-43. "Removal and Installation"](#), [SR-47. "Removal and Installation"](#).

### DTC Logic

INFOID:000000005253025

### DTC DETECTION LOGIC

With CONSULT-III

DTC No. Index ("SELF-DIAG [CURRENT]"), ("SELF-DIAG [PAST]" or "TROUBLE DIAG RECORD")

DTC No.	Trouble diagnosis name	DTC detecting condition	Possible cause
B1210	SIDE COLLISION DETECTION	Front side air bag, side curtain air bag is deployed.	—

### DTC CONFIRMATION PROCEDURE (With CONSULT-III)

#### 1.INSPECTION START

Turn ignition switch ON.

>> GO TO 2.

#### 2.CHECK SELF-DIAG RESULT

Check the screen of CONSULT-III.

Is malfunctioning part detected?

YES >> Refer to [SRC-301. "Diagnosis Procedure"](#).

NO >> **INSPECTION END.**

### Diagnosis Procedure

INFOID:000000005511351

#### **WARNING:**

- Before servicing, turn ignition switch OFF, disconnect battery negative terminal, and wait at least 3 minutes or more. (To discharge backup capacitor.)
- Never use unspecified tester or other measuring device.

#### 1.PERFORM COLLISION DIAGNOSIS

Perform collision diagnosis.Refer to [SR-32. "FOR SIDE AND ROLLOVER COLLISION : When SRS is activated in a collision"](#) or [SR-33. "FOR SIDE AND ROLLOVER COLLISION : When SRS is not activated in a collision"](#).

Is collision diagnosis complete?

YES >> GO TO 2.

NO >> **INSPECTION END**

## B1210 SIDE COLLISION DETECTION

< DTC/CIRCUIT DIAGNOSIS >

[FOR MEXICO]

---

### 2.FINAL INSPECTION

---

Perform "AIR BAG" Self Diagnostic Result.

Is the inspection result normal?

YES >> INSPECTION END

NO >> Perform diagnosis of applicable DTC.Refer to [SRC-303, "DTC Index"](#).

# DIAGNOSIS SENSOR UNIT

< ECU DIAGNOSIS INFORMATION >

[FOR MEXICO]

## ECU DIAGNOSIS INFORMATION

### DIAGNOSIS SENSOR UNIT

#### DTC Index

INFOID:000000005253027

#### DTC No. Index (With CONSULT-III)

("SELF-DIAG [CURRENT]"), ("SELF-DIAG [PAST]" or "TROUBLE DIAG RECORD")

#### NOTE:

Follow the procedures in numerical order when repairing malfunctioning parts. Confirm whether malfunction is eliminated using air bag warning lamp or CONSULT-III each time repair is completed. If malfunction is still observed, proceed to the next step. When malfunction is eliminated, further repair work is not required.

Diagnostic item	Explanation	Repair order "Recheck SRS at each replacement"
NO DTC IS DETECTED.	When malfunction is indicated by the "AIR BAG" warning lamp in User mode.	Low battery voltage (Less than 9 V) <ul style="list-style-type: none"> <li>Self-diagnosis result "SELF-DIAG [PAST]" (previously stored in the memory) might not be erased after repair.</li> <li>Intermittent malfunction has been detected in the past.</li> </ul>
	No malfunction is detected.	—
CONTROL UNIT [B1001-B1015] [B1026-B1031]	Diagnosis sensor is out of order.	Replace diagnosis sensor unit (ACU).
CRASH ZONE SEN [UNIT FAIL] [B1033] [B1034] CRASH ZONE SEN [COMM FAIL] [B1035] [UNMATCH] [B1036]  [OPEN/UPR-VB-SHORT] [B1038]  [SHORT/UPR-GND-SHORT] [B1040]	Crash zone sensor is out of order.	<ol style="list-style-type: none"> <li>Repair or replace wiring harness / harness connector.</li> <li>Replace crash zone sensor.</li> <li>Replace diagnosis sensor unit (ACU).</li> </ol>
CONTROL UNIT [B1042-B1047]	Diagnosis sensor is out of order.	Replace diagnosis sensor unit (ACU).

A  
B  
C  
D  
E  
F  
G  
I  
J  
K  
L  
M  
N  
O  
P

SRC

# DIAGNOSIS SENSOR UNIT

< ECU DIAGNOSIS INFORMATION >

[FOR MEXICO]

Diagnostic item	Explanation	Repair order "Recheck SRS at each replacement"
DRIVER AIRBAG MODULE [OPEN] [B1049]	Driver air bag module circuit is open. (including the spiral cable.)	<ol style="list-style-type: none"> <li>1. Repair or replace wiring harness/harness connector.</li> <li>2. Replace driver air bag module.</li> <li>3. Replace spiral cable. Refer to <a href="#">SRC-198, "Diagnosis Procedure"</a>.</li> <li>4. Replace diagnosis sensor unit (ACU).</li> </ol>
DRIVER AIRBAG MODULE [VB-SHORT] [B1050]	Driver air bag module circuit is shorted to some power supply circuit. (including the spiral cable.)	
DRIVER AIRBAG MODULE [GND-SHORT] [B1051]	Driver air bag module circuit is shorted to ground. (including the spiral cable.)	
DRIVER AIRBAG MODULE [SHORT] [B1052]	<ul style="list-style-type: none"> <li>• Driver air bag module circuits are shorted to each other. (including spiral cable.)</li> <li>• Driver air bag module circuit is shorted to itself.</li> </ul>	
CONTROL UNIT [B1058-B1063]	Diagnosis sensor is out of order.	Replace diagnosis sensor unit (ACU).
ASSIST A/B MODULE [OPEN] [B1065]	Front passenger air bag module circuit is open.	<ol style="list-style-type: none"> <li>1. Repair or replace wiring harness/harness connector.</li> <li>2. Replace front passenger air bag module.</li> <li>3. Replace diagnosis sensor unit (ACU).</li> </ol>
ASSIST A/B MODULE [VB-SHORT] [B1066]	Front passenger air bag module circuit is shorted to some power supply circuit.	
ASSIST A/B MODULE [GND-SHORT] [B1067]	Front passenger air bag module circuit is shorted to ground.	
ASSIST A/B MODULE [SHORT] [B1068]	<ul style="list-style-type: none"> <li>• Front passenger air bag module circuits are shorted to each other.</li> <li>• Front passenger air bag module circuit is shorted to itself.</li> </ul>	
CONTROL UNIT [B1074-B1079]	Diagnosis sensor is out of order.	Replace diagnosis sensor unit (ACU).
PRE-TEN FRONT RH [OPEN] [B1081]	Front RH seat belt pre-tensioner circuit is open.	<ol style="list-style-type: none"> <li>1. Repair or replace wiring harness/harness connector.</li> <li>2. Replace front RH seat belt pre-tensioner.</li> <li>3. Replace diagnosis sensor unit (ACU).</li> </ol>
PRE-TEN FRONT RH [VB-SHORT] [B1082]	Front RH seat belt pre-tensioner circuit is shorted to some power supply circuit.	
PRE-TEN FRONT RH [GND-SHORT] [B1083]	Front RH seat belt pre-tensioner circuit is shorted to ground.	
PRE-TEN FRONT RH [SHORT] [B1084]	<ul style="list-style-type: none"> <li>• Front RH seat belt pre-tensioner circuits are shorted to each other.</li> <li>• Front RH seat belt pre-tensioner circuit is shorted to itself.</li> </ul>	



# DIAGNOSIS SENSOR UNIT

< ECU DIAGNOSIS INFORMATION >

[FOR MEXICO]

Diagnostic item	Explanation	Repair order "Recheck SRS at each replacement"	A
PRE-TEN FRONT LH [OPEN] [B1086]	Front LH seat belt pre-tensioner circuit is open.	<ol style="list-style-type: none"> <li>1. Repair or replace wiring harness/harness connector.</li> <li>2. Replace front LH seat belt pre-tensioner.</li> <li>3. Replace diagnosis sensor unit (ACU).</li> </ol>	A
PRE-TEN FRONT LH [VB-SHORT] [B1087]	Front LH seat belt pre-tensioner circuit is shorted to some power supply circuit.		B
PRE-TEN FRONT LH [GND-SHORT] [B1088]	Front LH seat belt pre-tensioner circuit is shorted to ground.		C
PRE-TEN FRONT LH [SHORT] [B1089]	<ul style="list-style-type: none"> <li>• Front LH seat belt pre-tensioner circuits are shorted to each other.</li> <li>• Front LH seat belt pre-tensioner circuit is shorted to itself.</li> </ul>		D
CONTROL UNIT [B1106-B1111]	Diagnosis sensor is out of order.	Replace diagnosis sensor unit (ACU).	E
SATELLITE SENS RH [UNIT FAIL] [B1113] [B1114] SATELLITE SENS RH [COMM FAIL] [B1115] [UNMATCH] [B1116]	RH satellite sensor is out of order.	<ol style="list-style-type: none"> <li>1. Repair or replace wiring harness/harness connector.</li> <li>2. Replace RH satellite sensor.</li> <li>3. Replace diagnosis sensor unit (ACU).</li> </ol>	F
SATELLITE SENS LH [UNIT FAIL] [B1118] [B1119] SATELLITE SENS LH [COMM FAIL] [B1120] [UNMATCH] [B1121]	LH satellite sensor is out of order.		G
SATELLITE SENS LH [UNIT FAIL] [B1118] [B1119] SATELLITE SENS LH [COMM FAIL] [B1120] [UNMATCH] [B1121]	LH satellite sensor is out of order.	<ol style="list-style-type: none"> <li>1. Repair or replace wiring harness/harness connector.</li> <li>2. Replace LH satellite sensor.</li> <li>3. Replace diagnosis sensor unit (ACU).</li> </ol>	I
CONTROL UNIT [B1122-B1127]	Diagnosis sensor is out of order.		J
SIDE MODULE RH [OPEN] [B1129]	Front RH side air bag module circuit is open.	<ol style="list-style-type: none"> <li>1. Repair or replace wiring harness/harness connector.</li> <li>2. Replace front RH side air bag module.</li> <li>3. Replace diagnosis sensor unit (ACU).</li> </ol>	K
SIDE MODULE RH [VB-SHORT] [B1130]	Front RH side air bag module circuit is shorted to some power supply circuit.		L
SIDE MODULE RH [GND-SHORT] [B1131]	Front RH side air bag module circuit is shorted to ground.		M
SIDE MODULE RH [SHORT] [B1132]	<ul style="list-style-type: none"> <li>• Front LH seat belt pre-tensioner circuits are shorted to each other.</li> <li>• Front LH seat belt pre-tensioner circuit is shorted to itself.</li> </ul>		N
			O
			P

SRC

# DIAGNOSIS SENSOR UNIT

< ECU DIAGNOSIS INFORMATION >

[FOR MEXICO]

Diagnostic item	Explanation	Repair order "Recheck SRS at each replacement"
SIDE MODULE LH [OPEN] [B1134]	Front LH side air bag module circuit is open.	<ol style="list-style-type: none"> <li>1. Repair or replace wiring harness/harness connector.</li> <li>2. Replace front LH side air bag module.</li> <li>3. Replace diagnosis sensor unit (ACU).</li> </ol>
SIDE MODULE LH [VB-SHORT] [B1135]	Front LH side air bag module circuit is shorted to some power supply circuit.	
SIDE MODULE LH [GND-SHORT] [B1136]	Front LH side air bag module circuit is shorted to ground.	
SIDE MODULE LH [SHORT] [B1137]	<ul style="list-style-type: none"> <li>• Front LH side air bag module circuits are shorted to each other.</li> <li>• Front LH side air bag module circuit is shorted to itself.</li> </ul>	
CONTROL UNIT [B1138-B1143]	Diagnosis sensor is out of order.	Replace diagnosis sensor unit (ACU).
CURTAIN MODULE RH [OPEN] [B1145]	RH side curtain air bag module circuit is open.	<ol style="list-style-type: none"> <li>1. Repair or replace wiring harness/harness connector.</li> <li>2. Replace RH side curtain air bag module.</li> <li>3. Replace diagnosis sensor unit (ACU).</li> </ol>
CURTAIN MODULE RH [VB-SHORT] [B1146]	RH side curtain air bag module circuit is shorted to some power supply circuit.	
CURTAIN MODULE RH [GND-SHORT] [B1147]	RH side curtain air bag module circuit is shorted to ground.	
CURTAIN MODULE RH [SHORT] [B1148]	<ul style="list-style-type: none"> <li>• RH side curtain air bag module circuits are shorted to each other.</li> <li>• RH side curtain air bag module circuit is shorted to itself.</li> </ul>	
CURTAIN MODULE LH [OPEN] [B1150]	LH side curtain air bag module circuit is open.	<ol style="list-style-type: none"> <li>1. Repair or replace wiring harness/harness connector.</li> <li>2. Replace LH side curtain air bag module.</li> <li>3. Replace diagnosis sensor unit (ACU).</li> </ol>
CURTAIN MODULE LH [VB-SHORT] [B1151]	LH side curtain air bag module circuit is shorted to some power supply circuits.	
CURTAIN MODULE LH [GND-SHORT] [B1152]	LH side curtain air bag module circuit is shorted to ground.	
CURTAIN MODULE LH [SHORT] [B1153]	<ul style="list-style-type: none"> <li>• LH side curtain air bag module circuits are shorted to each other.</li> <li>• LH side curtain air bag module circuit is shorted to itself.</li> </ul>	
CONTROL UNIT [B1170-B1175]	Diagnosis sensor is out of order.	Replace diagnosis sensor unit (ACU).
PRE-TEN2 FRONT RH [OPEN] [B1177]	Front RH seat belt pre-tensioner 2 circuit is open.	<ol style="list-style-type: none"> <li>1. Repair or replace wiring harness/harness connector.</li> <li>2. Replace front RH seat belt pre-tensioner 2.</li> <li>3. Replace diagnosis sensor unit (ACU).</li> </ol>
PRE-TEN2 FRONT RH [VB-SHORT] [B1178]	Front RH seat belt pre-tensioner 2 circuit is shorted to some power supply circuit.	
PRE-TEN2 FRONT RH [GND-SHORT] [B1179]	Front RH seat belt pre-tensioner 2 circuit is shorted to ground.	
PRE-TEN2 FRONT RH [SHORT] [B1180]	<ul style="list-style-type: none"> <li>• Front RH seat belt pre-tensioner 2 circuits are shorted to each other.</li> <li>• Front RH seat belt pre-tensioner 2 circuit is shorted to itself.</li> </ul>	

# DIAGNOSIS SENSOR UNIT

< ECU DIAGNOSIS INFORMATION >

[FOR MEXICO]

Diagnostic item	Explanation	Repair order "Recheck SRS at each replacement"
PRE-TEN2 FRONT LH [OPEN] [B1182]	Front LH seat belt pre-tensioner 2 circuit is open.	<ol style="list-style-type: none"> <li>1. Repair or replace wiring harness/harness connector.</li> <li>2. Replace front LH seat belt pre-tensioner 2.</li> <li>3. Replace diagnosis sensor unit (ACU).</li> </ol>
PRE-TEN2 FRONT LH [VB-SHORT] [B1183]	Front LH seat belt pre-tensioner 2 circuit is shorted to some power supply circuit.	
PRE-TEN2 FRONT LH [GND-SHORT] [B1184]	Front LH seat belt pre-tensioner 2 circuit is shorted to ground.	
PRE-TEN2 FRONT LH [SHORT] [B1185]	<ul style="list-style-type: none"> <li>• Front LH seat belt pre-tensioner 2 circuits are shorted to each other.</li> <li>• Front LH seat belt pre-tensioner 2 circuit is shorted to itself.</li> </ul>	
CONTROL UNIT [B1202-B1207]	Diagnosis sensor is out of order.	Replace diagnosis sensor unit (ACU).
FRONTAL COLLISION DETECTION [B1209]	Seat belt pre-tensioner and front air bags is deployed.	Go to <a href="#">SRC-299, "Diagnosis Procedure"</a> .
SIDE COLLISION DETECTION [B1210]	Side and curtain air bag is deployed.	Go to <a href="#">SRC-301, "Diagnosis Procedure"</a> .

## WARNING LAMP FLASH CODE CHART (Without CONSULT-III)

### NOTE:

Follow the procedures in numerical order when repairing malfunctioning parts. Confirm whether malfunction is eliminated using air bag warning lamp or CONSULT-III each time repair is completed. If malfunction is still observed, proceed to the next step. When malfunction is eliminated, further repair work is not required.

<Diagnosis results (previously stored in the memory) might not be erased after repair or intermittent malfunctions have been detected in the past.>

Flash pattern	Repair order
<p>a through b are repeated.</p> <p>IGN ON</p>	<ol style="list-style-type: none"> <li>1. Erase memory. (Once key switch is turned from OFF to ON, TROUBLE DIAG RECORD will be erased.)</li> </ol>

PHIA0532E

<Diagnosis sensor unit>

Flash pattern	Repair order
<p>a through d are repeated.</p> <p>d: Seven flashes indicate malfunctioning diagnosis sensor unit circuit.</p>	<ol style="list-style-type: none"> <li>1. Replace the diagnosis sensor unit (ACU).</li> </ol>

JMHA0034GB

# DIAGNOSIS SENSOR UNIT

< ECU DIAGNOSIS INFORMATION >

[FOR MEXICO]

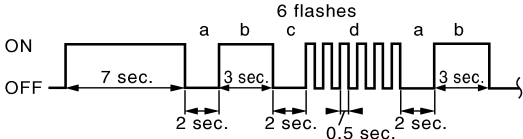
<Crash zone sensor>	
Flash pattern	Repair order
<p>a through d are repeated. d: Six flashes indicate malfunctioning crash zone sensor circuit.</p> 	<ol style="list-style-type: none"> <li>1. Visually check the wiring harness connection.</li> <li>2. Replace the harness if it has visible damage.</li> <li>3. Replace the crash zone sensor.</li> <li>4. Replace the diagnosis sensor unit.</li> </ol>

JMHIA0036GB

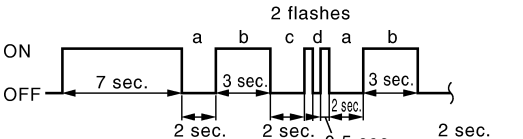
<Driver air bag module>	
Flash pattern	Repair order
<p>a through d are repeated. d: Two flashes indicate malfunctioning driver air bag module circuit.</p> 	<ol style="list-style-type: none"> <li>1. Visually check the wiring harness connection.</li> <li>2. Replace the harness if it has visible damage.</li> <li>3. Replace the driver air bag module.</li> <li>4. Replace the spiral cable.</li> <li>5. Replace the diagnosis sensor unit (ACU).</li> </ol>

JMHIA0033GB

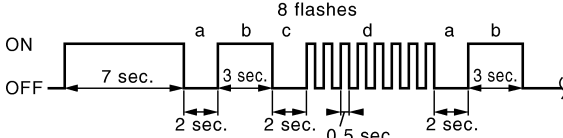
<Front passenger air bag module>	
Flash pattern	Repair order
<p>a through d are repeated. d: Eight flashes indicate malfunctioning front passenger air bag module circuit.</p> 	<ol style="list-style-type: none"> <li>1. Visually check the wiring harness connection.</li> <li>2. Replace the harness if it has visible damage.</li> <li>3. Replace the front passenger air bag module.</li> <li>4. Replace the diagnosis sensor unit (ACU).</li> </ol>

JMHIA0035GB

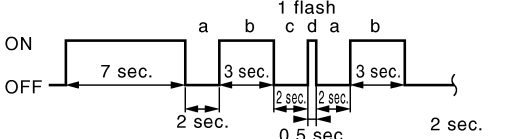
<Front RH seat belt pre-tensioner>	
Flash pattern	Repair order
<p>a through d are repeated. d: One flash indicates malfunctioning front RH seat belt pre-tensioner circuit.</p> 	<ol style="list-style-type: none"> <li>1. Visually check the wiring harness connections.</li> <li>2. Replace the harness if it has visible damage.</li> <li>3. Replace the front RH seat belt.</li> <li>4. Replace the diagnosis sensor unit (ACU).</li> </ol>

JMHIA0037GB

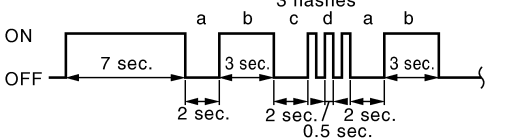
<Front LH seat belt pre-tensioner>	
Flash pattern	Repair order
<p>a through d are repeated. d: Three flashes indicate malfunctioning front LH seat belt pre-tensioner circuit.</p> 	<ol style="list-style-type: none"> <li>1. Visually check the wiring harness connections.</li> <li>2. Replace the harness if it has visible damage.</li> <li>3. Replace the front LH seat belt.</li> <li>4. Replace the diagnosis sensor unit (ACU).</li> </ol>

JMHIA0038GB

# DIAGNOSIS SENSOR UNIT

< ECU DIAGNOSIS INFORMATION >

[FOR MEXICO]

<RH side air bag (Satellite) sensor>	
Flash pattern	Repair order
<p>a through f are repeated. f: Three flashes indicate malfunctioning RH side air bag (Satellite) sensor circuit.</p>	<ol style="list-style-type: none"> <li>1. Visually check the wiring harness connection.</li> <li>2. Replace the harness if it has visible damage.</li> <li>3. Replace the RH side air bag (Satellite) sensor.</li> <li>4. Replace the diagnosis sensor unit.</li> </ol>

JMHIA0039GB

<LH side air bag (Satellite) sensor>	
Flash pattern	Repair order
<p>a through f are repeated. f: Four flashes indicate malfunctioning LH side air bag (Satellite) sensor.</p>	<ol style="list-style-type: none"> <li>1. Visually check the wiring harness connection.</li> <li>2. Replace the harness if it has visible damage.</li> <li>3. Replace the LH side air bag (Satellite) sensor.</li> <li>4. Replace the diagnosis sensor unit.</li> </ol>

JMHIA0040GB

<Front RH side air bag module>	
Flash pattern	Repair order
<p>a through f are repeated. f: One flash indicates malfunctioning front RH side air bag module circuit.</p>	<ol style="list-style-type: none"> <li>1. Visually check the wiring harness connection.</li> <li>2. Replace the harness if it has visible damage.</li> <li>3. Replace the front RH side air bag module.</li> <li>4. Replace the diagnosis sensor unit (ACU).</li> </ol>

JMHIA0041GB

<Front LH side air bag module>	
Flash pattern	Repair order
<p>a through f are repeated. f: Two flashes indicate malfunctioning front LH side air bag module circuit.</p>	<ol style="list-style-type: none"> <li>1. Visually check the wiring harness connection.</li> <li>2. Replace the harness if it has visible damage.</li> <li>3. Replace the front LH side air bag module.</li> <li>4. Replace the diagnosis sensor unit (ACU).</li> </ol>

JMHIA0042GB

<RH side curtain air bag module>	
Flash pattern	Repair order
<p>a through f are repeated. f: Five flashes indicate malfunctioning RH side curtain air bag module circuit.</p>	<ol style="list-style-type: none"> <li>1. Visually check the wiring harness connection.</li> <li>2. Replace the harness if it has visible damage.</li> <li>3. Replace the RH side curtain air bag module.</li> <li>4. Replace the diagnosis sensor unit (ACU).</li> </ol>

JMHIA0043GB

A

B

C

D

E

F

G

SRC

I

J

K

L

M

N

O

P

# DIAGNOSIS SENSOR UNIT

< ECU DIAGNOSIS INFORMATION >

[FOR MEXICO]

<LH side curtain air bag module>	
Flash pattern	Repair order
<p>a through f are repeated. f: Six flashes indicate malfunctioning LH side curtain air bag module circuit.</p> <p style="text-align: center;">6 flashes</p>	<ol style="list-style-type: none"> <li>1. Visually check the wiring harness connection.</li> <li>2. Replace the harness if it has visible damage.</li> <li>3. Replace the LH side curtain air bag module.</li> <li>4. Replace the diagnosis sensor unit (ACU).</li> </ol>

JMHIA0044GB

<Front RH seat belt pre-tensioner 2>	
Flash pattern	Repair order
<p>a through d are repeated. d: Twelve flashes indicates malfunctioning front RH seat belt pre-tensioner 2 circuit.</p> <p style="text-align: center;">12 flashes</p>	<ol style="list-style-type: none"> <li>1. Visually check the wiring harness connections.</li> <li>2. Replace the harness if it has visible damage.</li> <li>3. Replace the front RH seat belt pre-tensioner 2.</li> <li>4. Replace the diagnosis sensor unit (ACU).</li> </ol>

JMHIA0223GB

<Front LH seat belt pre-tensioner 2>	
Flash pattern	Repair order
<p>a through d are repeated. d: Thirteen flashes indicate malfunctioning front LH seat belt pre-tensioner 2 circuit.</p> <p style="text-align: center;">13 flashes</p>	<ol style="list-style-type: none"> <li>1. Visually check the wiring harness connections.</li> <li>2. Replace the harness if it has visible damage.</li> <li>3. Replace the front LH seat belt pre-tensioner 2.</li> <li>4. Replace the diagnosis sensor unit (ACU).</li> </ol>

JMHIA0222GB



# DIAGNOSIS SENSOR UNIT

< ECU DIAGNOSIS INFORMATION >

[FOR MEXICO]

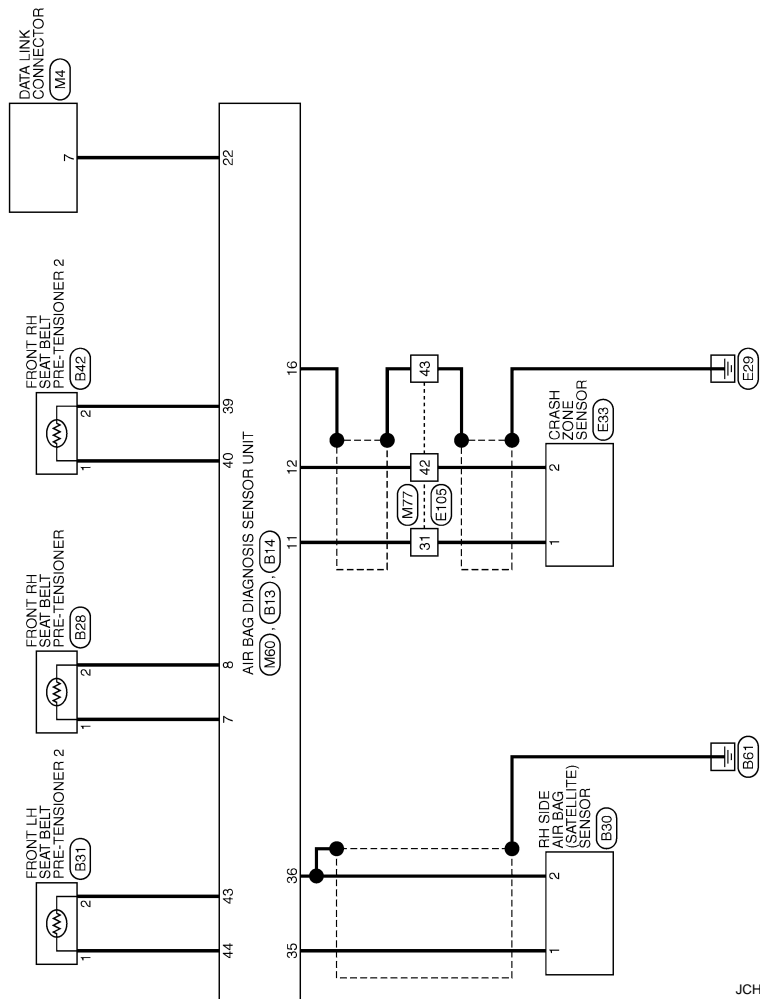

JCHWA0375GE



# DIAGNOSIS SENSOR UNIT

< ECU DIAGNOSIS INFORMATION >

[FOR MEXICO]

## SRS AIR BAG CONTROL SYSTEM (WITHOUT ADVANCED AIR BAG)

Connector No.	B13
Connector Name	AIR BAG DIAGNOSIS SENSOR UNIT
Connector Type	TK02FY-1V-EX

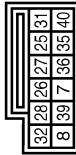

Terminal No.	Color of Wire	Signal Name [Specification]
7	O	ELR RH+
8	V	ELR RH-
27	R	INF CURTAIN RR RH+
28	W	INF CURTAIN RR RH-
31	W	SIDE INF RH+
32	L	SIDE INF RH-
35	BR	SIDE SENS RH+
36	Y	SIDE SENS RH-
38	GR	ELR2 RH-
40	P	ELR2 RH+ [Except for North America]

Connector No.	B14
Connector Name	AIR BAG DIAGNOSIS SENSOR UNIT
Connector Type	TK13FY-2V-EX

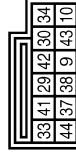

Terminal No.	Color of Wire	Signal Name [Specification]
9	Y	ELR LH+
10	SS	ELR LH-
29	LG	INF CURTAIN RR LH+
30	V	INF CURTAIN RR LH-
33	W	SIDE INF LH+
34	L	SIDE INF LH-
37	G	SIDE SENS LH+
38	R	SIDE SENS LH-
43	O	ELR2 LH-
44	P	ELR2 LH+ [Except for North America]

Connector No.	B18
Connector Name	FRONT LH SIDE AIR BAG MODULE
Connector Type	TK02FY-EX-1V



Terminal No.	Color of Wire	Signal Name [Specification]
1	W	-
2	L	-

Connector No.	B17
Connector Name	WIRE TO WIRE
Connector Type	TK04MY-BD



Terminal No.	Color of Wire	Signal Name [Specification]
2	V	-
4	LG	-

Connector No.	B18
Connector Name	FRONT RH SIDE AIR BAG MODULE
Connector Type	TK02FY-EX-1V



Terminal No.	Color of Wire	Signal Name [Specification]
1	W	-
2	L	-

Connector No.	B28
Connector Name	FRONT RH SEAT BELT PRE-TENSIONER
Connector Type	ACA02FY-2V



Terminal No.	Color of Wire	Signal Name [Specification]
1	O	-
2	V	-

Connector No.	B30
Connector Name	RH SIDE AIR BAG (SATELLITE) SENSOR
Connector Type	HK02FY-1V-EX



Terminal No.	Color of Wire	Signal Name [Specification]
1	BR	-
2	Y	-

Connector No.	B31
Connector Name	FRONT LH SEAT BELT PRE-TENSIONER
Connector Type	ACA02FOR



Terminal No.	Color of Wire	Signal Name [Specification]
1	P	-
2	O	-

A  
B  
C  
D  
E  
F  
G  
SRC  
I  
J  
K  
L  
M  
N  
O  
P

# DIAGNOSIS SENSOR UNIT

< ECU DIAGNOSIS INFORMATION >

[FOR MEXICO]

## SRS AIR BAG CONTROL SYSTEM (WITHOUT ADVANCED AIR BAG)

Connector No.	B35
Connector Name	FRONT LH SEAT BELT PRE-TENSIONER
Connector Type	ACA02FY-2V



Terminal No.	Color of Wire	Signal Name [Specification]
1	Y	-
2	SB	-

Connector No.	B37
Connector Name	LH SIDE AIR BAG (SATELLITE) SENSOR
Connector Type	HK02FY-1V-EX



Terminal No.	Color of Wire	Signal Name [Specification]
1	G	-
2	R	-

Connector No.	B42
Connector Name	FRONT RH SEAT BELT PRE-TENSIONER
Connector Type	ACA02FGR



Terminal No.	Color of Wire	Signal Name [Specification]
1	P	-
2	GR	-

Connector No.	B36
Connector Name	RH SIDE CURTAIN AIR BAG MODULE
Connector Type	ACA02FY-2V



Terminal No.	Color of Wire	Signal Name [Specification]
1	R	-
2	W	-

Connector No.	B88
Connector Name	WIRE TO WIRE
Connector Type	TK04FY



Terminal No.	Color of Wire	Signal Name [Specification]
2	V	-
4	LG	-

Connector No.	B72
Connector Name	LH SIDE CURTAIN AIR BAG MODULE
Connector Type	ACA02FY-2V



Terminal No.	Color of Wire	Signal Name [Specification]
1	LG	-
2	V	-

Connector No.	E33
Connector Name	CRASH ZONE SENSOR
Connector Type	HK02FY-1V-EX



Terminal No.	Color of Wire	Signal Name [Specification]
1	BR	-
2	Y	-

Connector No.	E105
Connector Name	WIRE TO WIRE
Connector Type	TH80FW-CS16-TM4



Terminal No.	Color of Wire	Signal Name [Specification]
31	BR	-
42	Y	-
43	SHIELD	-

# DIAGNOSIS SENSOR UNIT

< ECU DIAGNOSIS INFORMATION >

[FOR MEXICO]

## SRS AIR BAG CONTROL SYSTEM (WITHOUT ADVANCED AIR BAG)

Connector No.	M4
Connector Name	DATA LINK CONNECTOR
Connector Type	BD16FW

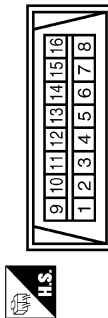

Terminal No.	Color of Wire	Signal Name [Specification]
7	O	-

Connector No.	M32
Connector Name	COMBINATION SWITCH (SPIRAL CABLE)
Connector Type	TK03FY-EX-1V



Terminal No.	Color of Wire	Signal Name [Specification]
23	Y/R	-
30	Y	-

Connector No.	M34
Connector Name	COMBINATION METER
Connector Type	SAB-40FW

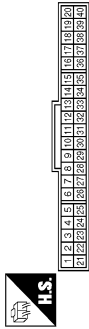

Terminal No.	Color of Wire	Signal Name [Specification]
2	O	IGN
3	B	GND(POWER)
15	LG	AIR BAG
23	B	GND(CIRCUIT)

Connector No.	M60
Connector Name	AIR BAG DIAGNOSIS SENSOR UNIT (WITHOUT ADVANCED AIR BAG)
Connector Type	TK20FY-EX-SC

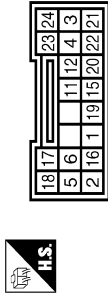

Terminal No.	Color of Wire	Signal Name [Specification]
1	R	IGN
2	B	GND
3	Y	INFLATOR DR+
4	Y/R	INFLATOR DR-
5	Y/G	INFLATOR AS+
6	Y/B	INFLATOR AS-
11	W	EGZS+
12	O	EGZS-
15	LG	A/B W/L
16	SHIELD	GND
22	Y	K-LINE

Connector No.	M70
Connector Name	FRONT PASSENGER AIR BAG MODULE (WITHOUT ADVANCED AIR BAG)
Connector Type	TK02FY-EX-1V

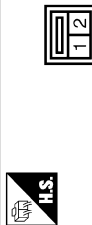

Terminal No.	Color of Wire	Signal Name [Specification]
1	Y/G	-
2	Y/B	-

Connector No.	M77
Connector Name	WIRE TO WIRE
Connector Type	TH80MW-CS16-TM4



Terminal No.	Color of Wire	Signal Name [Specification]
31	W	-
42	O	-
43	SHIELD	-

Connector No.	M350
Connector Name	DRIVER AIR BAG MODULE
Connector Type	ACA02FY-2V

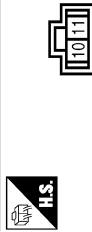

Terminal No.	Color of Wire	Signal Name [Specification]
10	-	-
11	-	-

A  
B  
C  
D  
E  
F  
G  
H  
I  
J  
K  
L  
M  
N  
O  
P

SRC

# SRS AIR BAG WARNING LAMP DOES NOT TURN OFF

< SYMPTOM DIAGNOSIS >

[FOR MEXICO]

## SYMPTOM DIAGNOSIS

### SRS AIR BAG WARNING LAMP DOES NOT TURN OFF

#### Diagnosis Procedure

INFOID:000000005253029

#### 1. CHECK AIR BAG MODULE

Check the deployment of air bag module.

Is air bag module deployed?

YES >> Refer to [SR-30. "FOR FRONTAL COLLISION : When SRS is activated in a collision"](#) or [SR-32. "FOR SIDE AND ROLLOVER COLLISION : When SRS is activated in a collision"](#).

NO >> GO TO 2.

#### 2. CHECK AIR BAG FUSE

Check the air bag fuse. Refer to [PG-90. "Fuse and Fusible Link Arrangement"](#).

Is 10A fuse [No.2, located in fuse block (J/B)] normal?

YES >> GO TO 4.

NO >> GO TO 3.

#### 3. CHECK AIR BAG FUSE AGAIN

Replace air bag fuse and turn ignition switch ON.

Did the air bag fuse blow again?

YES >> Repair or replace main harness.

NO >> **INSPECTION END**

#### 4. CHECK DIAGNOSIS SENSOR UNIT

Check the screen of CONSULT-III.

Is the inspection result normal?

YES >> GO TO 5.

NO >> Replace diagnosis sensor unit (ACU). Refer to [SR-49. "Removal and Installation"](#).

#### 5. CHECK HARNESS CONNECTION

Check harness connection between air bag warning lamp and diagnosis sensor unit.

Is the inspection result normal?

YES >> Check the intermittent incident. Refer to [GI-40. "Intermittent Incident"](#).

NO >> Replace wiring harness connector.

# SRS AIR BAG WARNING LAMP DOES NOT TURN ON

< SYMPTOM DIAGNOSIS >

[FOR MEXICO]

## SRS AIR BAG WARNING LAMP DOES NOT TURN ON

### Diagnosis Procedure

INFOID:000000005253030

"SRS AIR BAG" Warning Lamp Does Not Turn ON

#### 1.CHECK METER FUSE

Check the meter fuse. Refer to [PG-90, "Fuse and Fusible Link Arrangement"](#).

Is 10A fuse [No.4, located in fuse block (J/B)] normal?

YES >> GO TO 3.

NO >> GO TO 2.

#### 2.CHECK METER FUSE AGAIN

Replace 10A fuse [No.4, located in fuse block (J/B)] and turn ignition switch ON.

Did the meter fuse blow again?

YES >> Repair or replace the related harness.

NO >> **INSPECTION END**

#### 3.CHECK HARNESS CONNECTION

1. Check harness connection between diagnosis sensor unit and combination meter.

2. Disconnect diagnosis sensor unit connector and turn ignition switch ON.

Did air bag warning lamp turn ON?

YES >> Replace diagnosis sensor unit (ACU). Refer to [SR-49, "Removal and Installation"](#).

NO >> Replace combination meter assembly. Refer to [MWI-87, "Exploded View"](#).

A  
B  
C  
D  
E  
F  
G  
I  
J  
K  
L  
M  
N  
O  
P

SRC

**PRECAUTION****PRECAUTIONS****Precaution for Supplemental Restraint System (SRS) "AIR BAG" and "SEAT BELT PRE-TENSIONER"**

INFOID:000000005253031

The Supplemental Restraint System such as "AIR BAG" and "SEAT BELT PRE-TENSIONER", used along with a front seat belt, helps to reduce the risk or severity of injury to the driver and front passenger for certain types of collision. Information necessary to service the system safely is included in the "SRS AIR BAG" and "SEAT BELT" of this Service Manual.

**WARNING:**

- To avoid rendering the SRS inoperative, which could increase the risk of personal injury or death in the event of a collision which would result in air bag inflation, all maintenance must be performed by an authorized NISSAN/INFINITI dealer.
- Improper maintenance, including incorrect removal and installation of the SRS, can lead to personal injury caused by unintentional activation of the system. For removal of Spiral Cable and Air Bag Module, see the "SRS AIR BAG".
- Do not use electrical test equipment on any circuit related to the SRS unless instructed to in this Service Manual. SRS wiring harnesses can be identified by yellow and/or orange harnesses or harness connectors.

**PRECAUTIONS WHEN USING POWER TOOLS (AIR OR ELECTRIC) AND HAMMERS****WARNING:**

- When working near the Air Bag Diagnosis Sensor Unit or other Air Bag System sensors with the ignition ON or engine running, DO NOT use air or electric power tools or strike near the sensor(s) with a hammer. Heavy vibration could activate the sensor(s) and deploy the air bag(s), possibly causing serious injury.
- When using air or electric power tools or hammers, always switch the ignition OFF, disconnect the battery, and wait at least 3 minutes before performing any service.

**Service**

INFOID:000000005253032

- Do not use electrical test equipment to check SRS circuits unless instructed to in this Service Manual.
- Before servicing the SRS, turn ignition switch OFF, disconnect both battery cables and wait at least 3 minutes. For approximately 3 minutes after the cables are removed, it is still possible for the air bag and seat belt pretensioner to deploy. Therefore, do not work on any SRS connectors or wires until at least 3 minutes have elapsed.
- Diagnosis sensor unit must always be installed with their arrow marks "←" pointing towards the front of the vehicle for proper operation. Also check diagnosis sensor unit for cracks, deformities or rust before installation and replace as required.
- The spiral cable must be aligned in the neutral position since its rotations are limited. Do not turn steering wheel and column after removal of steering gear.
- Handle air bag module carefully. Always place driver and front passenger air bag modules with the pad side facing upward and seat mounted front side air bag module standing with the stud bolt side facing down.
- Conduct self-diagnosis to check entire SRS for proper functioning after replacing any components.
- After air bag inflates, the front instrument panel assembly should be replaced if damaged.
- Always replace instrument panel pad following front passenger air bag deployment.