

SECTION **FSU**
FRONT SUSPENSION

A
B
C
D

FSU

CONTENTS

SYMPTOM DIAGNOSIS	2	FRONT SUSPENSION ASSEMBLY	7	F
NOISE, VIBRATION AND HARSHNESS (NVH) TROUBLESHOOTING	2	Inspection	7	
NVH Troubleshooting Chart	2	WHEEL ALIGNMENT	8	G
PRECAUTION	3	Inspection	8	
PRECAUTIONS	3	REMOVAL AND INSTALLATION	9	H
FOR USA AND CANADA	3	FRONT COIL SPRING AND STRUT	9	
FOR USA AND CANADA : Precaution for Supplemental Restraint System (SRS) "AIR BAG" and "SEAT BELT PRE-TENSIONER"	3	Exploded View	9	I
FOR USA AND CANADA : Precaution Necessary for Steering Wheel Rotation After Battery Disconnect	3	Removal and Installation	10	
FOR USA AND CANADA : Precaution for Procedure without Cowl Top Cover	4	Disassembly and Assembly	10	J
FOR USA AND CANADA : Precautions for Suspension	4	Inspection	11	
FOR MEXICO	4	Disposal	12	K
FOR MEXICO : Precaution for Supplemental Restraint System (SRS) "AIR BAG" and "SEAT BELT PRE-TENSIONER"	4	TRANSVERSE LINK	13	
FOR MEXICO : Precaution Necessary for Steering Wheel Rotation After Battery Disconnect	4	Exploded View	13	L
FOR MEXICO : Precaution for Procedure without Cowl Top Cover	5	Removal and Installation	14	
FOR MEXICO : Precautions for Suspension	5	Inspection	14	M
PREPARATION	6	FRONT STABILIZER	16	
PREPARATION	6	Exploded View	16	N
Special Service Tool	6	Removal and Installation	17	
Commercial Service Tool	6	Inspection	17	O
PERIODIC MAINTENANCE	7	UNIT REMOVAL AND INSTALLATION	18	
		FRONT SUSPENSION MEMBER	18	P
		Exploded View	18	
		Removal and Installation	19	
		Inspection	19	
		SERVICE DATA AND SPECIFICATIONS (SDS)	20	
		SERVICE DATA AND SPECIFICATIONS (SDS)	20	
		Wheel Alignment	20	
		Ball Joint	20	
		Wheelarch Height	21	

NOISE, VIBRATION AND HARSHNESS (NVH) TROUBLESHOOTING

< SYMPTOM DIAGNOSIS >

SYMPTOM DIAGNOSIS

NOISE, VIBRATION AND HARSHNESS (NVH) TROUBLESHOOTING

NVH Troubleshooting Chart

INFOID:000000006203161

Use chart below to find the cause of the symptom. If necessary, repair or replace these parts.

Symptom		Possible cause and SUSPECTED PARTS													Reference page			
		Improper installation, looseness	Shock absorber deformation, damage or deflection	Bushing or mounting deterioration	Parts interference	Spring fatigue	Suspension looseness	Incorrect wheel alignment	Stabilizer bar fatigue	PROPELLER SHAFT (AWD)	DIFFERENTIAL (AWD)	FRONT AXLE AND FRONT SUSPENSION	TIRE	ROAD WHEEL	DRIVE SHAFT	BRAKE	STEERING	FSU-9, FSU-13, FSU-16 FSU-11
Symptom	FRONT SUSPENSION	Noise	x	x	x	x	x	x			x	x	x	x	x	x	x	
		Shake	x	x	x	x		x			x		x	x	x	x	x	x
		Vibration	x	x	x	x	x				x		x	x		x		x
		Shimmy	x	x	x	x			x				x	x	x		x	x
		Judder	x	x	x								x	x	x		x	x
		Poor quality ride or handling	x	x	x	x	x		x	x			x	x	x			

x: Applicable

PRECAUTIONS

< PRECAUTION >

PRECAUTION

PRECAUTIONS

FOR USA AND CANADA

FOR USA AND CANADA : Precaution for Supplemental Restraint System (SRS) "AIR BAG" and "SEAT BELT PRE-TENSIONER"

INFOID:000000006448843

The Supplemental Restraint System such as "AIR BAG" and "SEAT BELT PRE-TENSIONER", used along with a front seat belt, helps to reduce the risk or severity of injury to the driver and front passenger for certain types of collision. This system includes seat belt switch inputs and dual stage front air bag modules. The SRS system uses the seat belt switches to determine the front air bag deployment, and may only deploy one front air bag, depending on the severity of a collision and whether the front occupants are belted or unbelted. Information necessary to service the system safely is included in the "SRS AIR BAG" and "SEAT BELT" of this Service Manual.

WARNING:

- To avoid rendering the SRS inoperative, which could increase the risk of personal injury or death in the event of a collision that would result in air bag inflation, all maintenance must be performed by an authorized NISSAN/INFINITI dealer.
- Improper maintenance, including incorrect removal and installation of the SRS, can lead to personal injury caused by unintentional activation of the system. For removal of Spiral Cable and Air Bag Module, see "SRS AIR BAG".
- Never use electrical test equipment on any circuit related to the SRS unless instructed to in this Service Manual. SRS wiring harnesses can be identified by yellow and/or orange harnesses or harness connectors.

PRECAUTIONS WHEN USING POWER TOOLS (AIR OR ELECTRIC) AND HAMMERS

WARNING:

- When working near the Air Bag Diagnosis Sensor Unit or other Air Bag System sensors with the ignition ON or engine running, never use air or electric power tools or strike near the sensor(s) with a hammer. Heavy vibration could activate the sensor(s) and deploy the air bag(s), possibly causing serious injury.
- When using air or electric power tools or hammers, always switch the ignition OFF, disconnect the battery, and wait at least 3 minutes before performing any service.

FOR USA AND CANADA : Precaution Necessary for Steering Wheel Rotation After Battery Disconnect

INFOID:000000006448845

NOTE:

- This Procedure is applied only to models with Intelligent Key system and NATS (NISSAN ANTI-THEFT SYSTEM).
- Remove and install all control units after disconnecting both battery cables with the ignition switch in the "LOCK" position.
- Always use CONSULT-III to perform self-diagnosis as a part of each function inspection after finishing work. If DTC is detected, perform trouble diagnosis according to self-diagnostic results.

For models equipped with the Intelligent Key system and NATS, an electrically controlled steering lock mechanism is adopted on the key cylinder.

For this reason, if the battery is disconnected or if the battery is discharged, the steering wheel will lock and steering wheel rotation will become impossible.

If steering wheel rotation is required when battery power is interrupted, follow the procedure below before starting the repair operation.

OPERATION PROCEDURE

1. Connect both battery cables.

NOTE:

Supply power using jumper cables if battery is discharged.

2. Use the Intelligent Key or mechanical key to turn the ignition switch to the "ACC" position. At this time, the steering lock will be released.

A
B
C
D
FSU
F
G
H
I
J
K
L
M
N
O
P

PRECAUTIONS

< PRECAUTION >

3. Disconnect both battery cables. The steering lock will remain released and the steering wheel can be rotated.
4. Perform the necessary repair operation.
5. When the repair work is completed, return the ignition switch to the "LOCK" position before connecting the battery cables. (At this time, the steering lock mechanism will engage.)
6. Perform a self-diagnosis check of all control units using CONSULT-III.

FOR USA AND CANADA : Precaution for Procedure without Cowl Top Cover

INFOID:000000006448847

When performing the procedure after removing cowl top cover, cover the lower end of windshield with urethane, etc.

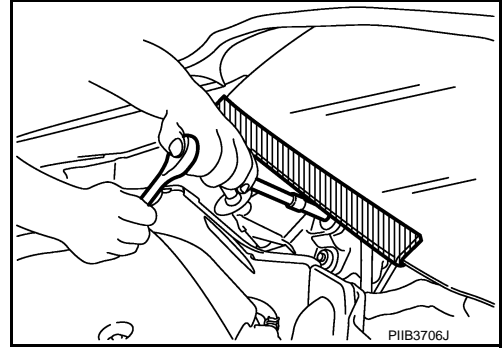

FOR USA AND CANADA : Precautions for Suspension

INFOID:000000006203165

- When installing rubber bushings, the final tightening must be carried out under unladen conditions with tires on ground. Spilled oil might shorten the life of rubber bushings. Be sure to wipe off any spilled oil.
- Unladen conditions mean that fuel, engine coolant and lubricant are full. Spare tire, jack, hand tools and mats are in designated positions.
- After servicing suspension parts, be sure to check wheel alignment.
- Self-lock nuts are not reusable. Always use new ones when installing. Since new self-lock nuts are pre-oiled, tighten as they are.

FOR MEXICO

FOR MEXICO : Precaution for Supplemental Restraint System (SRS) "AIR BAG" and "SEAT BELT PRE-TENSIONER"

INFOID:000000006448844

The Supplemental Restraint System such as "AIR BAG" and "SEAT BELT PRE-TENSIONER", used along with a front seat belt, helps to reduce the risk or severity of injury to the driver and front passenger for certain types of collision. Information necessary to service the system safely is included in the "SRS AIR BAG" and "SEAT BELT" of this Service Manual.

WARNING:

- **To avoid rendering the SRS inoperative, which could increase the risk of personal injury or death in the event of a collision which would result in air bag inflation, all maintenance must be performed by an authorized NISSAN/INFINITI dealer.**
- **Improper maintenance, including incorrect removal and installation of the SRS, can lead to personal injury caused by unintentional activation of the system. For removal of Spiral Cable and Air Bag Module, see "SRS AIR BAG".**
- **Never use electrical test equipment on any circuit related to the SRS unless instructed to in this Service Manual. SRS wiring harnesses can be identified by yellow and/or orange harnesses or harness connectors.**

PRECAUTIONS WHEN USING POWER TOOLS (AIR OR ELECTRIC) AND HAMMERS

WARNING:

- **When working near the Air Bag Diagnosis Sensor Unit or other Air Bag System sensors with the ignition ON or engine running, never use air or electric power tools or strike near the sensor(s) with a hammer. Heavy vibration could activate the sensor(s) and deploy the air bag(s), possibly causing serious injury.**
- **When using air or electric power tools or hammers, always switch the ignition OFF, disconnect the battery, and wait at least 3 minutes before performing any service.**

FOR MEXICO : Precaution Necessary for Steering Wheel Rotation After Battery Dis-

PRECAUTIONS

< PRECAUTION >

connect

INFOID:000000006448846

NOTE:

- This Procedure is applied only to models with Intelligent Key system and NATS (NISSAN ANTI-THEFT SYSTEM).
- Remove and install all control units after disconnecting both battery cables with the ignition switch in the "LOCK" position.
- Always use CONSULT-III to perform self-diagnosis as a part of each function inspection after finishing work. If DTC is detected, perform trouble diagnosis according to self-diagnostic results.

For models equipped with the Intelligent Key system and NATS, an electrically controlled steering lock mechanism is adopted on the key cylinder.

For this reason, if the battery is disconnected or if the battery is discharged, the steering wheel will lock and steering wheel rotation will become impossible.

If steering wheel rotation is required when battery power is interrupted, follow the procedure below before starting the repair operation.

OPERATION PROCEDURE

1. Connect both battery cables.

NOTE:

Supply power using jumper cables if battery is discharged.

2. Use the Intelligent Key or mechanical key to turn the ignition switch to the "ACC" position. At this time, the steering lock will be released.
3. Disconnect both battery cables. The steering lock will remain released and the steering wheel can be rotated.
4. Perform the necessary repair operation.
5. When the repair work is completed, return the ignition switch to the "LOCK" position before connecting the battery cables. (At this time, the steering lock mechanism will engage.)
6. Perform a self-diagnosis check of all control units using CONSULT-III.

FOR MEXICO : Precaution for Procedure without Cowl Top Cover

INFOID:000000006448848

When performing the procedure after removing cowl top cover, cover the lower end of windshield with urethane, etc.

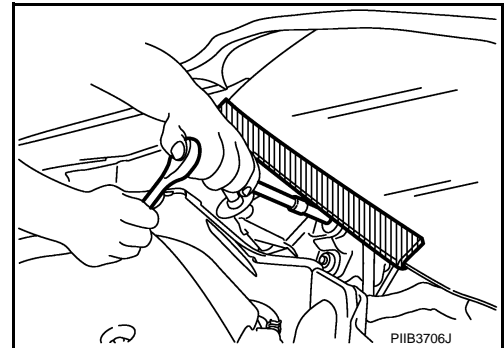

FOR MEXICO : Precautions for Suspension

INFOID:000000006203169

- When installing rubber bushings, the final tightening must be carried out under unladen conditions with tires on ground. Spilled oil might shorten the life of rubber bushings. Be sure to wipe off any spilled oil.
- Unladen conditions mean that fuel, engine coolant and lubricant are full. Spare tire, jack, hand tools and mats are in designated positions.
- After servicing suspension parts, be sure to check wheel alignment.
- Self-lock nuts are not reusable. Always use new ones when installing. Since new self-lock nuts are pre-oiled, tighten as they are.

PREPARATION

< PREPARATION >

PREPARATION

PREPARATION

Special Service Tool

INFOID:000000006203170

The actual shapes of Kent-More tools may differ from those of special service tools illustrated here.

Tool number (Kent-More No.) Tool name	Description
ST35652000 (—) Strut attachment	Disassembling and assembling strut

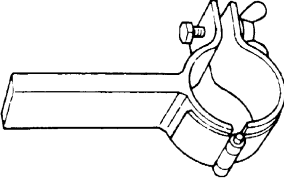

ZZA0807D

Commercial Service Tool

INFOID:000000006203171

Tool name	Description
Spring compressor	Removing and installing coil spring
Power tool	Loosening bolts and nuts

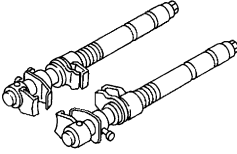

S-NT717

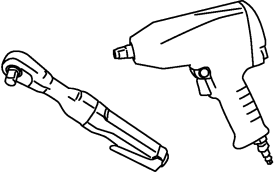

PBIC0190E

FRONT SUSPENSION ASSEMBLY

< PERIODIC MAINTENANCE >

PERIODIC MAINTENANCE

FRONT SUSPENSION ASSEMBLY

Inspection

INFOID:000000006203172

MOUNTING INSPECTION

Make sure the mounting conditions (looseness, backlash) of each component and component conditions (wear, damage) are normal.

BALL JOINT AXIAL END PLAY

1. Set front wheels in a straight-ahead position.

CAUTION:

Never depress brake pedal when measuring.

2. Place an iron bar or equivalent between transverse link and steering knuckle.
3. Measure axial end play by prying it up and down.

Standard

End play : Refer to [FSU-20, "Ball Joint"](#).

CAUTION:

Be careful not to damage ball joint boot. Never damage the installation position by applying excessive force.

STRUT ASSEMBLY

Check for oil leakage and damage, and replace if necessary.

A
B
C
D
E
F
G
H
I
J
K
L
M
N
O
P

FSU

WHEEL ALIGNMENT

< PERIODIC MAINTENANCE >

WHEEL ALIGNMENT

Inspection

INFOID:000000006203173

DESCRIPTION

CAUTION:

- **Camber, caster, kingpin inclination angles cannot be adjusted.**
- **If camber, caster, or kingpin inclination angle is outside the standard, check front suspension parts for wear and damage. Replace suspect parts if a malfunction is detected.**
- **Kingpin inclination angle is reference value, no inspection is required.**
- Measure wheel alignment under unladen conditions.

NOTE:

“Unladen conditions” means that fuel, engine coolant, and lubricant are full. Spare tire, jack, hand tools and mats are in designated positions.

PRELIMINARY CHECK

Check the following:

- Tires for improper air pressure and wear.
- Road wheels for runout. Refer to [WT-46, "Inspection"](#).
- Wheel bearing axial end play. Refer to [FAX-11, "Inspection"](#) (2WD), [FAX-35, "Inspection"](#) (AWD).
- Transverse link ball joint axial end play. Refer to [FSU-14, "Inspection"](#).
- Shock absorber operation.
- Each mounting part of axle and suspension for looseness and deformation.
- Each of suspension member, shock absorber and transverse link for cracks, deformation and other damage.
- Vehicle height (posture).

GENERAL INFORMATION AND RECOMMENDATIONS

- A four-wheel thrust alignment should be performed.
- This type of alignment is recommended for any NISSAN/INFINITI vehicle.
- The four-wheel “thrust” process helps ensure that the vehicle is properly aligned and the steering wheel is centered.
- The alignment rack itself should be capable of accepting any NISSAN/INFINITI vehicle.
- The rack should be checked to ensure that it is level.
- Make sure the machine is properly calibrated.
- Your alignment equipment should be regularly calibrated in order to give correct information.
- Check with the manufacturer of your specific equipment for their recommended Service/Calibration Schedule.

ALIGNMENT PROCESS

IMPORTANT:

Use only the alignment specifications listed in this Service Manual.

- When displaying the alignment settings, many alignment machines use “indicators”: (Green/red, plus or minus, Go/No Go). **Do not use these indicators.**
- The alignment specifications programmed into your machine that operate these indicators may not be correct.
- This may result in an ERROR.
- Some newer alignment machines are equipped with an “optional Rolling Compensation” method to “compensate” the sensors (alignment targets or head units). **Do not use this “Rolling Compensation” method.**
- Use the “Jacking Compensation Method”. After installing the alignment targets or head units, raise the vehicle and rotate the wheels 1/2 turn both ways.
- See Instructions in the alignment machine you're using for more information on this.

FRONT COIL SPRING AND STRUT

< REMOVAL AND INSTALLATION >

REMOVAL AND INSTALLATION

FRONT COIL SPRING AND STRUT

Exploded View

INFOID:000000006203174

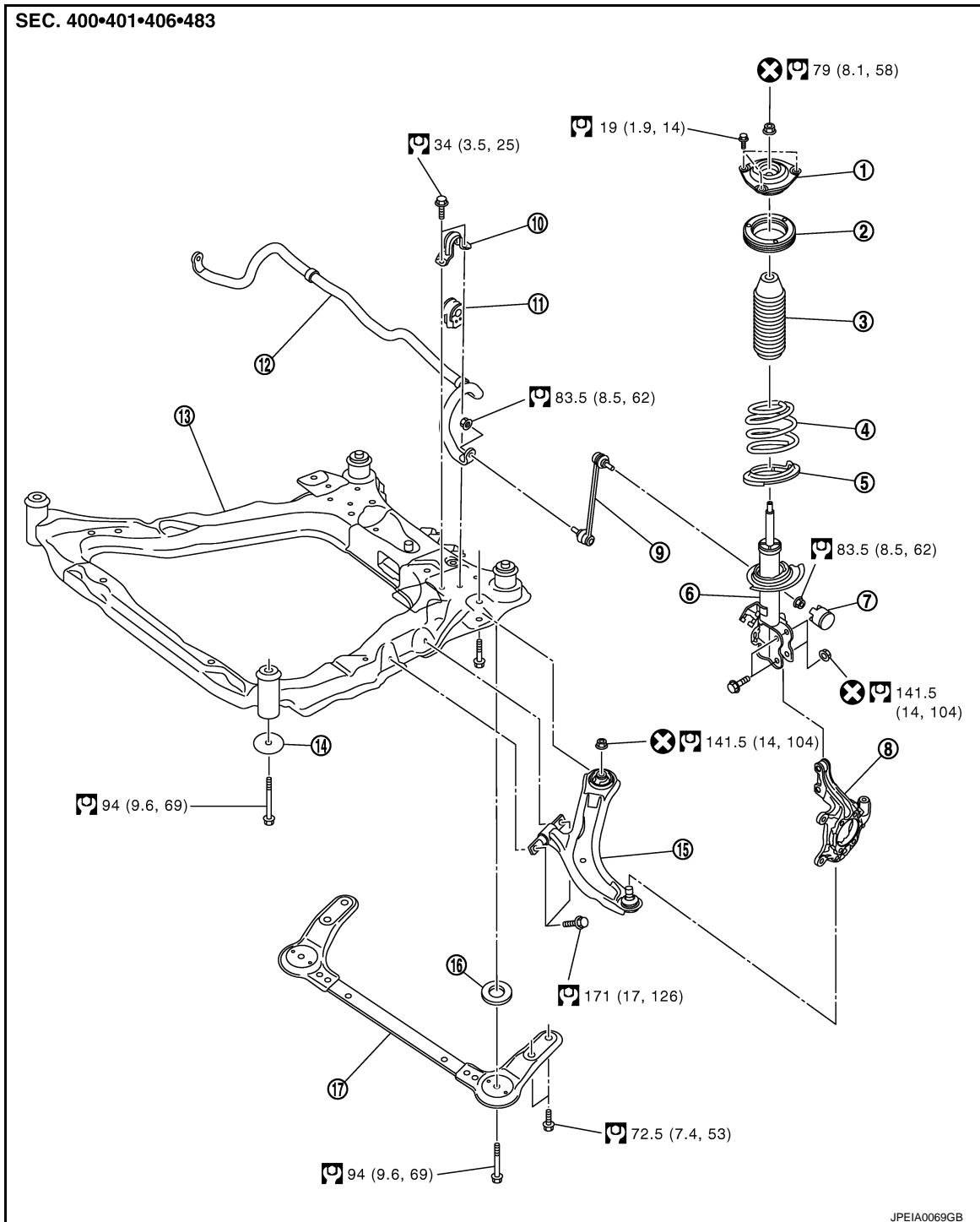

- | | | |
|-----------------------------|-------------------------------|------------------------------|
| 1. Strut mounting insulator | 2. Strut mounting bearing | 3. Bound bumper |
| 4. Coil spring | 5. Lower rubber seat | 6. Strut |
| 7. Cap | 8. Steering knuckle | 9. Stabilizer connecting rod |
| 10. Stabilizer clamp | 11. Stabilizer bushing | 12. Stabilizer bar |
| 13. Front suspension member | 14. Rebound stopper insulator | 15. Transverse link |

A
B
C
D
E
F
G
H
I
J
K
L
M
N
O
P

FSU

FRONT COIL SPRING AND STRUT

< REMOVAL AND INSTALLATION >

16. Rebound stopper
17. Front suspension member stay
- Refer to [GI-4, "Components"](#) for symbols in the figure.

Removal and Installation

INFOID:000000006203175

REMOVAL

1. Remove tires with power tool.
2. Remove lock plat. Refer to [BR-22, "FRONT : Exploded View"](#).
3. Remove cap and mounting nut on the upper side of stabilizer connecting rod, and then remove stabilizer connecting rod from strut assembly with power tool.
4. Separate steering knuckle from strut assembly.
5. Remove mounting bolts of strut mounting insulator, and then remove strut assembly with power tool.

INSTALLATION

Note the following, and install in the reverse order of removal.

- Become it in arrow mark (B) for identification mark (A) an illustration to the body outside.

⇐ : Vehicle front

- Perform final tightening of bolts and nuts, under unladen conditions with tires on level ground.

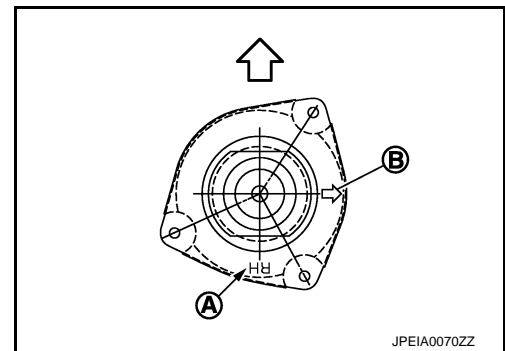

Disassembly and Assembly

INFOID:000000006203176

DISASSEMBLY

CAUTION:

Never damage strut assembly piston rod when removing components from strut assembly.

1. Install strut attachment (A) [SST: ST35652000 (—)] to strut assembly and secure it in a vise.

CAUTION:

When installing the strut attachment to strut assembly, wrap a shop cloth around strut to protect from damage.

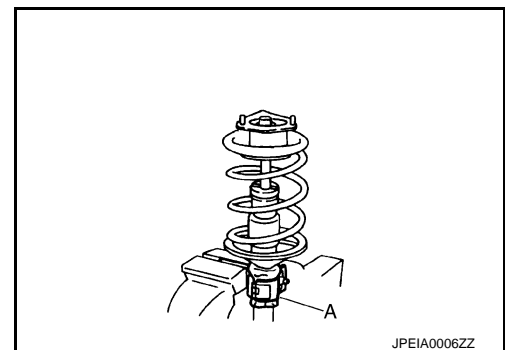

2. Using a spring compressor (A) (commercial service tool), compress coil spring between strut mounting bearing and lower rubber seat (on strut assembly) until coil spring with a spring compressor is free.

CAUTION:

Be sure a spring compressor is securely attached to coil spring. Compress coil spring.

3. Make sure coil spring with a spring compressor between strut mounting bearing and lower rubber seat (strut assembly) is free. And then remove piston rod lock nut while securing the piston rod tip so that piston rod does not turn.

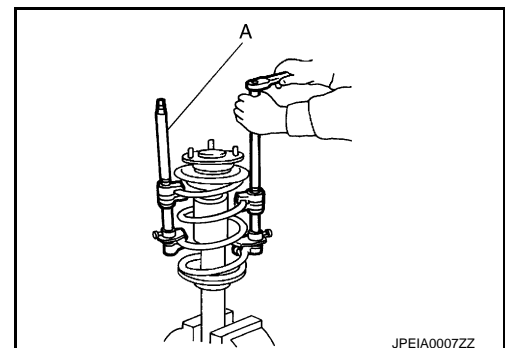

4. Remove strut mounting insulator and strut mounting bearing, and bound bumper from strut.

5. After remove coil spring with a spring compressor, and then gradually release a spring compressor.

FRONT COIL SPRING AND STRUT

< REMOVAL AND INSTALLATION >

CAUTION:

Loosen while making sure coil spring attachment position does not move.

6. Remove lower rubber seat from strut.
7. Remove the strut attachment [SST: ST35652000 (—)] from strut.

ASSEMBLY

1. Install strut attachment [SST: ST35652000 (—)] to strut and secure it in a vise.

CAUTION:

When installing the strut attachment to strut assembly, wrap a shop cloth around strut to protect from damage.

2. Install lower rubber seat.
3. Install bound bumper onto strut mounting insulator.
4. Compress coil spring using a spring compressor (commercial service tool), and install it onto strut assembly.

CAUTION:

- Face tube side of coil spring (1) downward. Align the lower end (A) to lower rubber seat (2).
- Be sure a compressor is securely attached to coil spring. Compress coil spring.
- Set coil spring so that its paint marks are aligned with the positions of 1.75 turns and 2.75 turns from the bottom end of the coil spring.

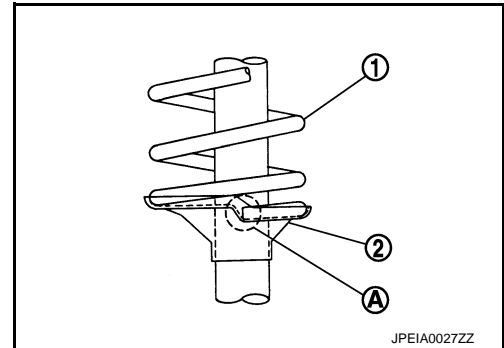

5. Install strut mounting bearing and strut mounting insulator with bound bumper to strut.
 - Installation position of strut mounting insulator is shown in the figure.

A : Identification mark

B : Arrow mark

⇐ : Vehicle front

6. Secure piston rod tip so that piston rod does not turn, then tighten piston rod lock nut with specified torque.

CAUTION:

Never reuse piston rod lock nut.

7. Gradually release a spring compressor, and remove coil spring.

CAUTION:

Loosen while making sure coil spring attachment position does not move.

8. Remove the strut attachment from strut assembly.

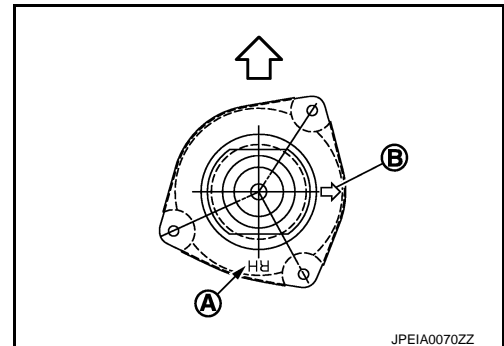

Inspection

INFOID:000000006203177

INSPECTION AFTER INSTALLATION

1. Check wheel alignment. Refer to [FSU-8. "Inspection"](#).
2. Adjust neutral position of steering angle sensor. Refer to [BRC-76. "ADJUSTMENT OF STEERING ANGLE SENSOR NEUTRAL POSITION : Special Repair Requirement"](#) (with VDC).

INSPECTION AFTER DISASSEMBLY

Strut

Check the following items, and replace the parts if necessary.

- Strut for deformation, cracks or damage
- Piston rod for damage, uneven wear or distortion
- Oil leakage

FRONT COIL SPRING AND STRUT

< REMOVAL AND INSTALLATION >

Strut Mounting Insulator and Rubber Parts Inspection

Check strut mounting insulator for cracks and rubber parts for wear. Replace it if necessary.

Coil Spring

Check coil spring for cracks, wear or damage. Replace it if necessary.

Disposal

INFOID:000000006203178

1. Set strut assembly horizontally to the ground with the piston rod fully extracted.
2. Drill 2 – 3 mm (0.08 – 0.12 in) hole at the position (●) from top as shown in the figure to release gas gradually.

CAUTION:

- Wear eye protection (safety glasse).
- Wear gloves.
- Be careful with metal chips or oil blown out by the compressed gas.

NOTE:

- Drill vertically in this direction (←).
- Directly to the outer tube avoiding brackets.
- The gas is clear, colorless, odorless, and harmless.

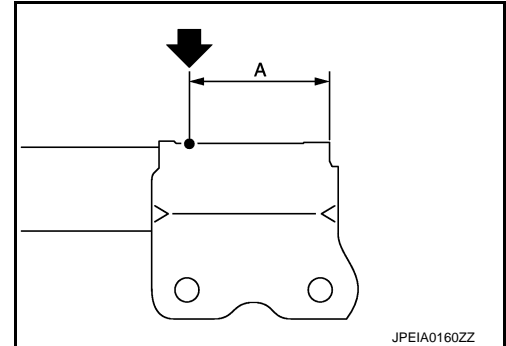

JPEIA0160ZZ

A: 20 – 30 mm (0.79 – 1.18 in)

3. Position the drilled hole downward and drain oil by moving the piston rod several times.

CAUTION:

Dispose of drained oil according to the law and local regulations.

TRANSVERSE LINK

< REMOVAL AND INSTALLATION >

TRANSVERSE LINK

Exploded View

INFOID:000000006203179

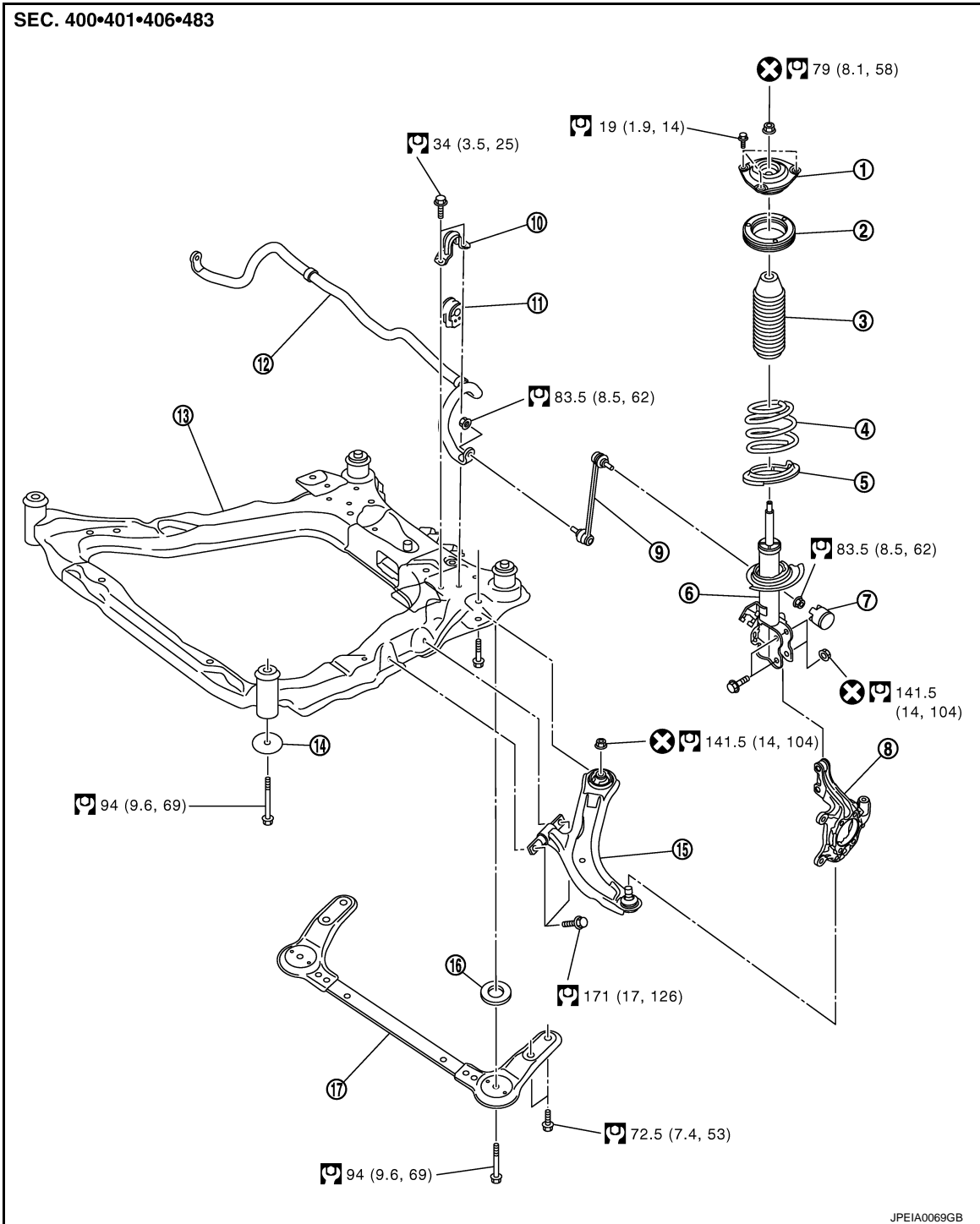

- | | | |
|-----------------------------|----------------------------------|------------------------------|
| 1. Strut mounting insulator | 2. Strut mounting bearing | 3. Bound bumper |
| 4. Coil spring | 5. Lower rubber seat | 6. Strut |
| 7. Cap | 8. Steering knuckle | 9. Stabilizer connecting rod |
| 10. Stabilizer clamp | 11. Stabilizer bushing | 12. Stabilizer bar |
| 13. Front suspension member | 14. Rebound stopper insulator | 15. Transverse link |
| 16. Rebound stopper | 17. Front suspension member stay | |

Refer to [GI-4, "Components"](#) for symbols in the figure.

TRANSVERSE LINK

< REMOVAL AND INSTALLATION >

Removal and Installation

INFOID:000000006203180

REMOVAL

1. Remove tires with power tool.
2. Remove transverse link from steering knuckle. Refer to [FAX-10, "Exploded View"](#) (2WD), [FAX-34, "Exploded View"](#) (AWD).
3. Remove transverse link from suspension member.

NOTE:

Transverse link cannot be pulled out because the mounting bolt (←) of transverse link at the rear of the mounting area located on the front side of vehicle hits against the stabilizer bar. Therefore, get stabilizer bar out of the way to remove the transverse link.

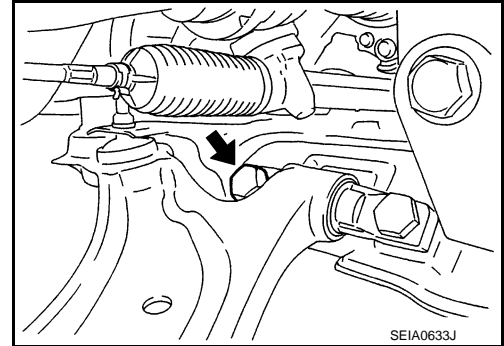

INSTALLATION

Note the following, and install in the reverse order of removal.

- Perform final tightening of bolts and nuts at the front suspension member, under unladen conditions with tires on level ground.

Inspection

INFOID:000000006203181

INSPECTION AFTER REMOVAL

Visual Inspection

Check the following:

- Transverse link and bushing for deformation, cracks or damage. Replace it if necessary.
- Ball joint boot for cracks or other damage, and also for grease leakage. Replace it if necessary.

Ball Joint Inspection

Manually move ball stud to confirm it moves smoothly with no binding.

Swing Torque Inspection

NOTE:

Before measurement, move ball stud at least ten times by hand to check for smooth movement.

- Hook a spring balance (A) at cutout (B) on ball stud. Confirm spring balance measurement value is within specifications when ball stud begins moving.

Standard

Swing torque :Refer to [FSU-20, "Ball Joint"](#).

Spring balance measurement :Refer to [FSU-20, "Ball Joint"](#).

- If swing torque exceeds standard range, replace transverse link assembly.

Axial End Play Inspection

- Move tip of ball stud in axial direction to check for looseness.

Standard

Axial end play :Refer to [FSU-20, "Ball Joint"](#).

- If axial end play exceeds the standard value, replace transverse link assembly.

INSPECTION AFTER INSTALLATION

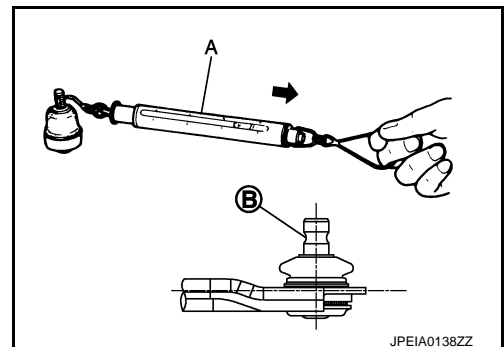

TRANSVERSE LINK

< REMOVAL AND INSTALLATION >

1. Check wheel alignment. Refer to [FSU-8. "Inspection"](#).
2. Adjust neutral position of steering angle sensor. Refer to [BRC-76. "ADJUSTMENT OF STEERING ANGLE SENSOR NEUTRAL POSITION : Special Repair Requirement"](#) (with VDC).

A

B

C

D

FSU

F

G

H

I

J

K

L

M

N

O

P

FRONT STABILIZER

< REMOVAL AND INSTALLATION >

Removal and Installation

INFOID:000000006203183

REMOVAL

1. Remove tires power tool.
2. Remove under cover from vehicle.
3. Remove steering outer socket from steering knuckle. Refer to [ST-15. "Exploded View"](#).
4. Remove stabilizer connecting rod.
5. Remove rear torque rod. Refer to [EM-62. "Exploded View"](#).
6. Separate intermediate shaft from steering gear. Refer to [ST-12. "Exploded View"](#).
7. Set suitable jack under front suspension member.
8. Remove front suspension member stay from vehicle.
9. Gradually lower jack front suspension member in order to remove stabilizer mounting bolts.

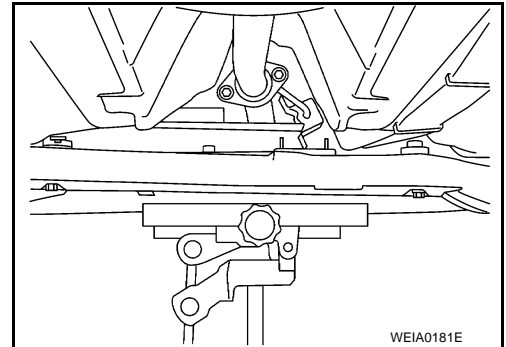

10. Remove mounting bolts (↔) of stabilizer clamp, and then remove stabilizer clamp and stabilizer bushing from front suspension member.
11. Remove stabilizer bar.

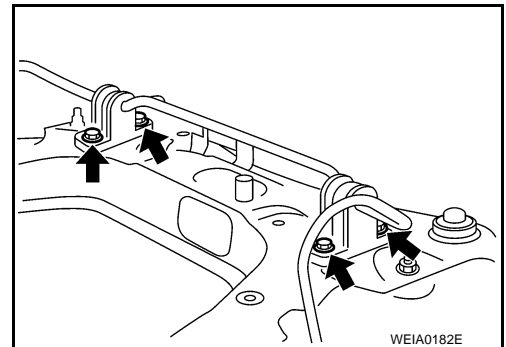

INSTALLATION

Note the following, and install in the reverse order of removal.

- Install stabilizer clamp that notch (A) becomes vehicle front side (↔).
- Install stabilizer bushing that slit (B) becomes vehicle front side (↔).

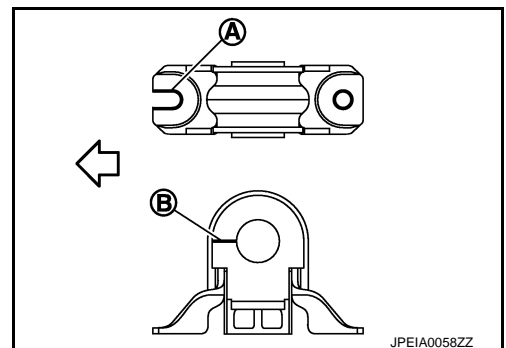

Inspection

INFOID:000000006203184

INSPECTION AFTER REMOVAL

Check stabilizer bar, stabilizer connecting rod, stabilizer bushing and stabilizer clamp for deformation, cracks or damage. Replace it if necessary.

FRONT SUSPENSION MEMBER

< UNIT REMOVAL AND INSTALLATION >

16. Rebound stopper

17. Front suspension member stay

Refer to [GI-4, "Components"](#) for symbols in the figure.

Removal and Installation

INFOID:000000006203186

REMOVAL

1. Remove tires with power tool.
2. Remove under cover from vehicle.
3. Remove wheel sensor from steering knuckle. Refer to [BRC-66, "FRONT WHEEL SENSOR : Exploded View"](#) (without VDC), [BRC-175, "FRONT WHEEL SENSOR : Exploded View"](#) (with VDC).
CAUTION:
Never pull on wheel sensor harness.
4. Remove upper side of stabilizer connecting rod from strut assembly.
5. Remove steering outer socket from steering knuckle. Refer to [ST-15, "Exploded View"](#).
6. Separate intermediate shaft from steering gear. Refer to [ST-12, "Exploded View"](#).
7. Remove transverse link from steering knuckle. Refer to [FAX-10, "Exploded View"](#) (2WD), [FAX-34, "Exploded View"](#) (AWD).
8. Remove rear torque rod. Refer to [EM-62, "Exploded View"](#).
9. Set suitable jack front suspension member.
10. Remove front suspension member stay from vehicle.
11. Remove mounting bolts and nuts of front suspension member.
12. Gradually lower jack to remove front suspension assembly from vehicle.
CAUTION:
Secure suspension assembly to suitable jack while removing it.
13. Remove mounting bolts and nuts, and then remove transverse link, stabilizer bar from front suspension member.

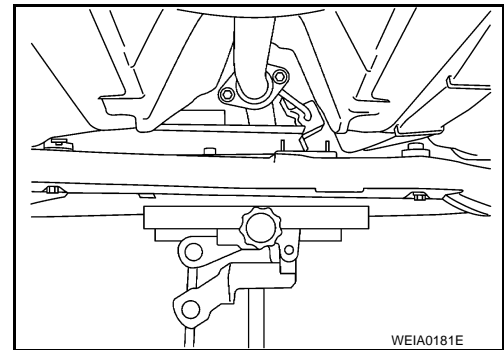

INSTALLATION

Note the following, and install in the reverse order of removal.

- Perform final tightening of installation position between front suspension member and transverse links (rubber bushing) under unladen condition with tires on level ground.
- Check wheel sensor harness for proper connection. Refer to [BRC-66, "FRONT WHEEL SENSOR : Exploded View"](#) (without VDC), [BRC-175, "FRONT WHEEL SENSOR : Exploded View"](#) (with VDC).

Inspection

INFOID:000000006203187

INSPECTION AFTER REMOVAL

Check the front suspension member for significant deformation, cracks, or damages. Replace it if necessary.

INSPECTION AFTER INSTALLATION

1. Check wheel alignment. Refer to [FSU-8, "Inspection"](#).
2. Adjust the neutral position of the steering angle sensor. Refer to [BRC-76, "ADJUSTMENT OF STEERING ANGLE SENSOR NEUTRAL POSITION : Special Repair Requirement"](#) (with VDC).

SERVICE DATA AND SPECIFICATIONS (SDS)

< SERVICE DATA AND SPECIFICATIONS (SDS)

SERVICE DATA AND SPECIFICATIONS (SDS)

SERVICE DATA AND SPECIFICATIONS (SDS)

Wheel Alignment

INFOID:000000006203188

Item		Standard					
		2WD			AWD		
Wheel size		16 inch	17 inch	18 inch	16 inch	17 inch	18 inch
Camber Degree minute (Decimal degree)	Mini- mum	Left side	-1° 00' (-1.00°)				
		Right side	-1° 15' (-1.25°)				
	Nomi- nal	Left side	-0° 15' (-0.25°)				
		Right side	-0° 30' (-0.50°)				
	Maxi- mum	Left side	0° 30' (0.50°)				
		Right side	0° 15' (0.25°)				
Left and right differ- ence		0° 33' (0.55°) or less					
Caster Degree minute (Decimal degree)	Minimum	3° 55' (3.92°)	4° 00' (4.00°)				
	Nominal	4° 40' (4.67°)	4° 45' (4.75°)				
	Maximum	5° 25' (5.41°)	5° 30' (5.50°)				
	Left and right differ- ence	0° 36' (0.60°) or less					
Kingpin inclination Degree minute (Decimal degree)	Minimum	9° 45' (9.75°)					
	Nominal	10° 30' (10.50°)					
	Maximum	11° 15' (11.25°)					
Toe- in	Total toe-in Distance	Minimum	In 1 mm (0.04 in)				
		Nominal	In 2 mm (0.08 in)				
		Maximum	In 3 mm (0.12 in)				
	Toe angle (left wheel or right wheel) Degree minute (Decimal degree)	Minimum	In 0° 02' 30" (0.05°)				
		Nominal	In 0° 05' (0.08°)				
		Maximum	In 0° 07' 30" (0.12°)				

Measure value under unladen* conditions.

*: Fuel, engine coolant and lubricant are full. Spare tire, jack, hand tools and mats are in designated positions.

Ball Joint

INFOID:000000006203189

Item		Standard
Swing torque	Transverse link	0.5 – 3.4 N·m (0.06 – 0.34 kg-m, 5 – 30 in-lb)
Measurement on spring balance	Transverse link	13.5 – 91.9 N (1.4 – 9.3 kg, 3 – 21 lb)
Axial end play		0 mm (0 in)

SERVICE DATA AND SPECIFICATIONS (SDS)

< SERVICE DATA AND SPECIFICATIONS (SDS)

Wheelarch Height

INFOID:000000006203190

Wheel size	Front (Hf)	Rear (Hr)
16 inch	789 mm (31.06 in)	811 mm (31.93 in)
17 inch	788 mm (31.02 in)	810 mm (31.89 in)
18 inch	792 mm (31.18 in)	813 mm (32.01 in)

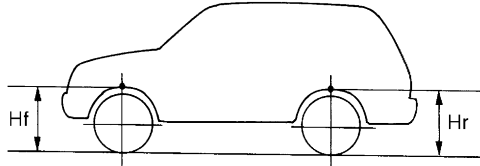

SFA746B

Measure value under unladen* conditions.

*: Fuel, engine coolant and lubricant are full. Spare tire, jack, hand tools and mats are in designated positions.

A
B
C
D
FSU
F
G
H
I
J
K
L
M
N
O
P