

SECTION **INT**  
INTERIOR

A  
B  
C  
D  
E  
F  
G  
H  
I  
INT  
K  
L  
M  
N  
O  
P

CONTENTS

<b>SYMPTOM DIAGNOSIS</b> .....	2	<b>REMOVAL AND INSTALLATION</b> .....	13
<b>SQUEAK AND RATTLE TROUBLE DIAG- NOSES</b> .....	2	<b>DOOR FINISHER</b> .....	13
Work Flow .....	2	<b>FRONT DOOR FINISHER</b> .....	13
Inspection Procedure .....	4	FRONT DOOR FINISHER : Exploded View .....	13
Diagnostic Worksheet .....	6	FRONT DOOR FINISHER : Removal and Installa- tion .....	13
<b>PRECAUTION</b> .....	8	<b>REAR DOOR FINISHER</b> .....	15
<b>PRECAUTIONS</b> .....	8	REAR DOOR FINISHER : Exploded View .....	16
<b>FOR MEXICO</b> .....	8	REAR DOOR FINISHER : Removal and Installa- tion .....	16
FOR MEXICO : Precaution for Supplemental Re- straint System (SRS) "AIR BAG" and "SEAT BELT PRE-TENSIONER" .....	8	<b>BODY SIDE TRIM</b> .....	19
FOR MEXICO : Precaution Necessary for Steer- ing Wheel Rotation After Battery Disconnect .....	8	Exploded View .....	19
FOR MEXICO : Precaution for Work .....	9	Removal and Installation .....	19
<b>FOR USA AND CANADA</b> .....	9	<b>FLOOR TRIM</b> .....	23
FOR USA AND CANADA : Precaution for Supple- mental Restraint System (SRS) "AIR BAG" and "SEAT BELT PRE-TENSIONER" .....	9	Exploded View .....	23
FOR USA AND CANADA : Precaution Necessary for Steering Wheel Rotation After Battery Discon- nect .....	9	Removal and Installation .....	23
FOR USA AND CANADA : Precaution for Work ....	10	<b>HEADLINING</b> .....	25
<b>PREPARATION</b> .....	11	<b>NORMAL ROOF</b> .....	25
<b>PREPARATION</b> .....	11	NORMAL ROOF : Exploded View .....	25
Special Service Tools .....	11	NORMAL ROOF : Removal and Installation .....	25
Commercial Service Tools .....	11	<b>SUNROOF</b> .....	27
<b>CLIP LIST</b> .....	12	SUNROOF : Exploded View .....	28
Clip List .....	12	SUNROOF : Removal and Installation .....	28
		<b>LUGGAGE FLOOR TRIM</b> .....	32
		Exploded View .....	32
		Removal and Installation .....	33
		<b>BACK DOOR TRIM</b> .....	35
		Exploded View .....	35
		Removal and Installation .....	35

# SQUEAK AND RATTLE TROUBLE DIAGNOSES

< SYMPTOM DIAGNOSIS >

## SYMPTOM DIAGNOSIS

### SQUEAK AND RATTLE TROUBLE DIAGNOSES

#### Work Flow

INFOID:000000006201279

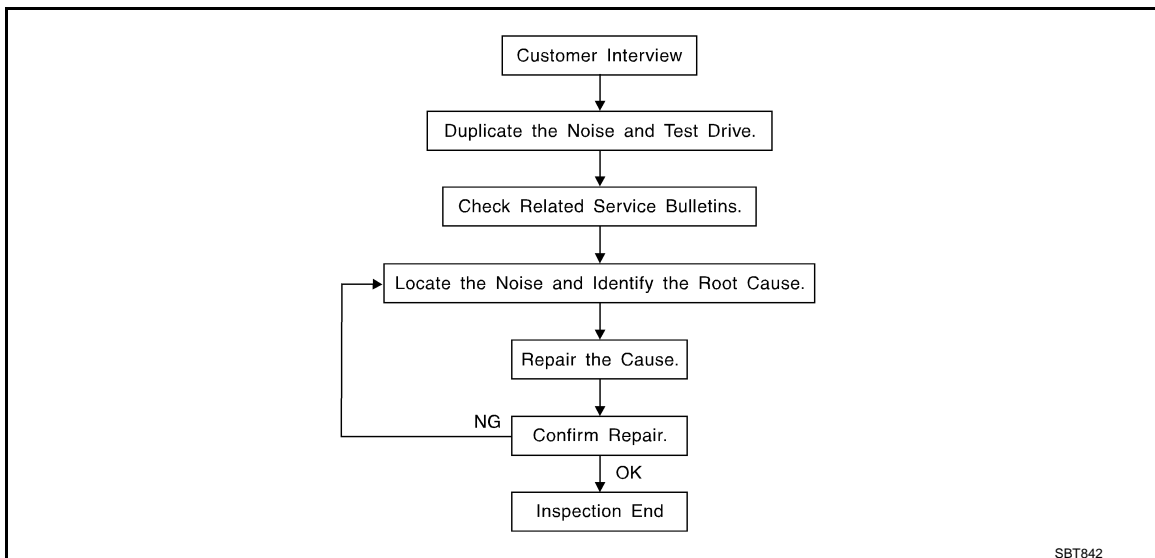

#### CUSTOMER INTERVIEW

Interview the customer if possible, to determine the conditions that exist when the noise occurs. Use the Diagnostic Worksheet during the interview to document the facts and conditions when the noise occurs and any of customer's comments; refer to [INT-6. "Diagnostic Worksheet"](#). This information is necessary to duplicate the conditions that exist when the noise occurs.

- The customer may not be able to provide a detailed description or the location of the noise. Attempt to obtain all the facts and conditions that exist when the noise occurs (or does not occur).
- If there is more than one noise in the vehicle, perform a diagnosis and repair the noise that the customer is concerned about. This can be accomplished by performing a cruise test on the vehicle with the customer.
- After identifying the type of noise, isolate the noise in terms of its characteristics. The noise characteristics are provided so the customer, service adviser and technician are all speaking the same language when defining the noise.
- Squeak – (Like tennis shoes on a clean floor)  
Squeak characteristics include the light contact/fast movement/brought on by road conditions/hard surfaces = higher pitch noise/softer surfaces = lower pitch noises/edge to surface = chirping
- Creak – (Like walking on an old wooden floor)  
Creak characteristics include firm contact/slow movement/twisting with a rotational movement/pitch dependent on materials/often brought on by activity.
- Rattle – (Like shaking a baby rattle)  
Rattle characteristics include the fast repeated contact/vibration or similar movement/loose parts/missing clip or fastener/incorrect clearance.
- Knock – (Like a knock on a door)  
Knock characteristics include hollow sounding/sometimes repeating/often brought on by driver action.
- Tick – (Like a clock second hand)  
Tick characteristics include gentle contacting of light materials/loose components/can be caused by driver action or road conditions.
- Thump – (Heavy, muffled knock noise)  
Thump characteristics include softer knock/dead sound often brought on by activity.
- Buzz – (Like a bumblebee)  
Buzz characteristics include high frequency rattle/firm contact.
- Often the degree of acceptable noise level will vary depending up on the person. A noise that a technician may judge as acceptable may be very irritating to the customer.
- Weather conditions, especially humidity and temperature, may have a great effect on noise level.

#### DUPLICATE THE NOISE AND TEST DRIVE

# SQUEAK AND RATTLE TROUBLE DIAGNOSES

## < SYMPTOM DIAGNOSIS >

If possible, drive the vehicle with the customer until the noise is duplicated. Note any additional information on the Diagnostic Worksheet regarding the conditions or location of the noise. This information can be used to duplicate the same conditions when the repair is reconfirmed.

If the noise can be duplicated easily during the test drive, to help identify the source of the noise, try to duplicate the noise with the vehicle stopped by doing one or all of the following:

- 1) Close a door.
  - 2) Tap or push/pull around the area where the noise appears to be coming from.
  - 3) Rev the engine.
  - 4) Use a floor jack to recreate vehicle "twist".
  - 5) At idle, apply engine load (electrical load, half-clutch on M/T models, drive position on A/T models).
  - 6) Raise the vehicle on a hoist and hit a tire with a rubber hammer.
- Drive the vehicle and attempt to duplicate the conditions the customer states exist when the noise occurs.
  - If it is difficult to duplicate the noise, drive the vehicle slowly on an undulating or rough road to stress the vehicle body.

## CHECK RELATED SERVICE BULLETINS

After verifying the customer concern or symptom, check ASIST for Technical Service Bulletins (TSBs) related to that concern or symptom.

If a TSB relates to the symptom, follow the procedure to repair the noise.

## LOCATE THE NOISE AND IDENTIFY THE ROOT CAUSE

1. Narrow down the noise to a general area. To help pinpoint the source of the noise, use a listening tool (Chassis ear: J-39570, Engine ear and mechanics stethoscope).
2. Narrow down the noise to a more specific area and identify the cause of the noise by:
  - Removing the components in the area that is are suspected to be the cause of the noise.  
Do not use too much force when removing clips and fasteners, otherwise clips and fastener can be broken or lost during the repair, resulting in the creation of new noise.
  - Tapping or pushing/pulling the component that is are suspected to be the cause of the noise.  
Do not tap or push/pull the component with excessive force, otherwise the noise will be eliminated only temporarily.
  - Feeling for a vibration by hand by touching the component(s) that is are suspected to be the cause of the noise.
  - Placing a piece of paper between components that are suspected to be the cause of the noise.
  - Looking for loose components and contact marks.  
Refer to [INT-4, "Inspection Procedure"](#).

## REPAIR THE CAUSE

- If the cause is a loose component, tighten the component securely.
- If the cause is insufficient clearance between components:
  - Separate components by repositioning or loosening and retightening the component, if possible.
  - Insulate components with a suitable insulator such as urethane pads, foam blocks, felt cloth tape or urethane tape. A Nissan Squeak and Rattle Kit (J-43980) is available through the authorized Nissan Parts Department.

### **CAUTION:**

**Never use excessive force as many components are constructed of plastic and may be damaged.**

### **NOTE:**

Always check with the Parts Department for the latest parts information.

The following materials are contained in the Nissan Squeak and Rattle Kit (J-43980). Each item can be ordered separately as needed.

URETHANE PADS [1.5 mm (0.059 in) thick]

Insulates connectors, harness, etc.

- 76268-9E005: 100 × 135 mm (3.937 × 5.315 in)
- 76884-71L01: 60 × 85 mm (2.362 × 3.346 in)
- 76884-71L02: 15 × 25 mm (0.591 × 0.984 in)

INSULATOR (Foam blocks)

Insulates components from contact. Can be used to fill space behind a panel.

- 73982-9E000: 45 mm (1.772 in) thick, 50 × 50 mm (1.969 × 1.969 in)
- 73982-50Y00: 10 mm (0.394 in) thick, 50 × 50 mm (1.969 × 1.969 in)

INSULATOR (Light foam block)

80845-71L00: 30 mm (1.18 in) thick, 30 × 50 mm (1.181 × 1.969in)

FELT CLOTHTAPE

# SQUEAK AND RATTLE TROUBLE DIAGNOSES

## < SYMPTOM DIAGNOSIS >

---

Used to insulate where movement does not occur. Ideal for instrument panel applications.

- 68370-4B000: 15 × 25 mm (0.591 × 0.984 in) pad
- 68239-13E00: 5 mm (0.197 in) wide tape roll

The following materials, not found in the kit, can also be used to repair squeaks and rattles.

### UHMW (TEFLON) TAPE

Insulates where slight movement is present. Ideal for instrument panel applications.

### SILICONE GREASE

Used in place of UHMW tape that is be visible or does not fit. Will only last a few months.

### SILICONE SPRAY

Used when grease cannot be applied.

### DUCT TAPE

Used to eliminate movement.

## CONFIRM THE REPAIR

Confirm that the cause of a noise is repaired by test driving the vehicle. Operate the vehicle under the same conditions as when the noise originally occurred. Refer to the notes on the Diagnostic Worksheet.

## Inspection Procedure

INFOID:000000006201280

Refer to Table of Contents for specific component removal and installation information.

## INSTRUMENT PANEL

Most incidents are caused by contact and movement between:

1. The cluster lid A and instrument panel
2. Acrylic lens and combination meter housing
3. Instrument panel to front pillar garnish
4. Instrument panel to windshield
5. Instrument panel mounting pins
6. Wiring harnesses behind the combination meter
7. A/C defroster duct and duct joint

These incidents can usually be located by tapping or moving the components to duplicate the noise or by pressing on the components while driving to stop the noise. Most of these incidents can be repaired by applying felt cloth tape or silicon spray (in hard to reach areas). Urethane pads can be used to insulate wiring harness.

### **CAUTION:**

**Never use silicone spray to isolate a squeak or rattle. If the area is saturated with silicone, the recheck of repair becomes impossible.**

## CENTER CONSOLE

Components to pay attention to include:

1. Shifter assembly cover to finisher
2. A/C control unit and cluster lid C
3. Wiring harnesses behind audio and A/C control unit

The instrument panel repair and isolation procedures also apply to the center console.

## DOORS

Pay attention to the following:

1. Finisher and inner panel making a slapping noise
2. Inside handle escutcheon to door finisher
3. Wiring harnesses tapping
4. Door striker out of alignment causing a popping noise on starts and stops

Tapping or moving the components or pressing on them while driving to duplicate the conditions can isolate many of these incidents. The areas can usually be insulated with felt cloth tape or insulator foam blocks from the Nissan Squeak and Rattle Kit (J-43980) to repair the noise.

## TRUNK

Trunk noises are often caused by a loose jack or loose items put into the trunk by the customer.

In addition look for the following:

1. Trunk lid dumpers out of adjustment

# SQUEAK AND RATTLE TROUBLE DIAGNOSES

## < SYMPTOM DIAGNOSIS >

---

2. Trunk lid striker out of adjustment
3. The trunk lid torsion bars knocking together
4. A loose license plate or bracket

Most of these incidents can be repaired by adjusting, securing or insulating the item(s) or component(s) causing the noise.

## SUNROOF/HEADLINING

Noises in the sunroof/headlining area can often be traced to one of the following:

1. Sunroof lid, rail, linkage or seals making a rattle or light knocking noise
2. Sunvisor shaft shaking in the holder
3. Front or rear windshield touching headlining and squeaking

Again, pressing on the components to stop the noise while duplicating the conditions can isolate most of these incidents. Repairs usually consist of insulating with felt cloth tape.

## SEATS

When isolating seat noise it's important to note the position the seats in and the load placed on the seat when the noise occurs. These conditions should be duplicated when verifying and isolating the cause of the noise.

Cause of seat noise include:

1. Headrest rods and holder
2. A squeak between the seat pad cushion and frame
3. The rear seatback lock and bracket

These noises can be isolated by moving or pressing on the suspected components while duplicating the conditions under which the noise occurs. Most of these incidents can be repaired by repositioning the component or applying urethane tape to the contact area.

## UNDERHOOD

Some interior noise may be caused by components under the hood or on the engine wall. The noise is then transmitted into the passenger compartment.

Causes of transmitted underhood noise include:

1. Any component mounted to the engine wall
2. Components that pass through the engine wall
3. Engine wall mounts and connectors
4. Loose radiator mounting pins
5. Hood bumpers out of adjustment
6. Hood striker out of adjustment

These noises can be difficult to isolate since they cannot be reached from the interior of the vehicle. The best method is to secure, move or insulate one component at a time and test drive the vehicle. Also, engine RPM or load can be changed to isolate the noise. Repairs can usually be made by moving, adjusting, securing, or insulating the component causing the noise.

A  
B  
C  
D  
E  
F  
G  
H  
I  
K  
L  
M  
N  
O  
P

INT

# SQUEAK AND RATTLE TROUBLE DIAGNOSES

< SYMPTOM DIAGNOSIS >

## Diagnostic Worksheet

INFOID:000000006201281



### SQUEAK & RATTLE DIAGNOSTIC WORKSHEET

Dear Nissan Customer:

We are concerned about your satisfaction with your Nissan vehicle. Repairing a squeak or rattle sometimes can be very difficult. To help us fix your Nissan right the first time, please take a moment to note the area of the vehicle where the squeak or rattle occurs and under what conditions. You may be asked to take a test drive with a service advisor or technician to ensure we confirm the noise you are hearing.

#### I. WHERE DOES THE NOISE COME FROM? (circle the area of the vehicle)

The illustrations are for reference only, and may not reflect the actual configuration of your vehicle.

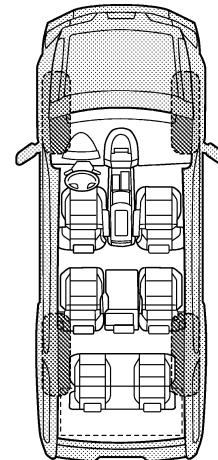
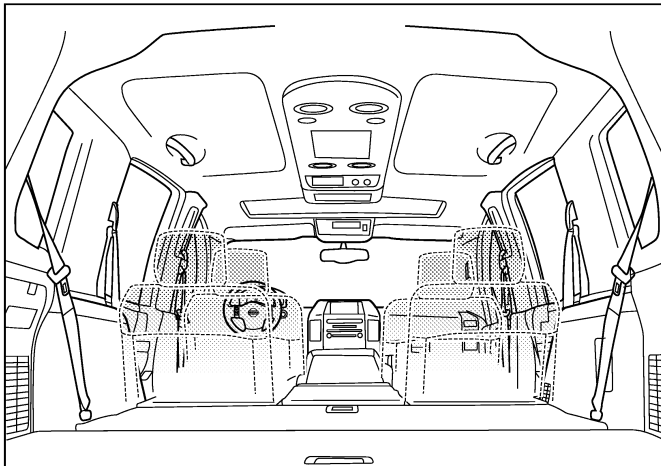
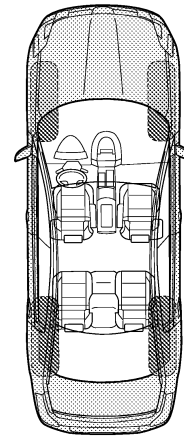
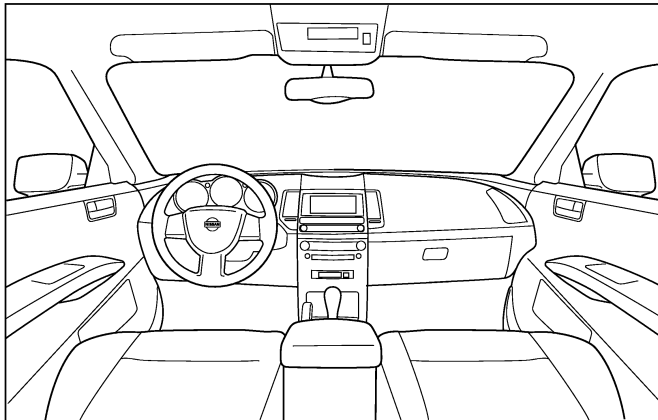

Continue to page 2 of the worksheet and briefly describe the location of the noise or rattle. In addition, please indicate the conditions which are present when the noise occurs.

PIIB8740E

# SQUEAK AND RATTLE TROUBLE DIAGNOSES

< SYMPTOM DIAGNOSIS >

## SQUEAK & RATTLE DIAGNOSTIC WORKSHEET - page 2

Briefly describe the location where the noise occurs:

---

---

### II. WHEN DOES IT OCCUR? (please check the boxes that apply)

- |   |  |
|---|--|
| <input type="checkbox"/> anytime                      | <input type="checkbox"/> after sitting out in the rain |
| <input type="checkbox"/> 1st time in the morning      | <input type="checkbox"/> when it is raining or wet     |
| <input type="checkbox"/> only when it is cold outside | <input type="checkbox"/> dry or dusty conditions       |
| <input type="checkbox"/> only when it is hot outside  | <input type="checkbox"/> other:                        |

### III. WHEN DRIVING:

- through driveways
- over rough roads
- over speed bumps
- only about \_\_\_\_ mph
- on acceleration
- coming to a stop
- on turns: left, right or either (circle)
- with passengers or cargo
- other: \_\_\_\_\_
- after driving \_\_\_\_ miles or \_\_\_\_ minutes

### IV. WHAT TYPE OF NOISE

- squeak (like tennis shoes on a clean floor)
- creak (like walking on an old wooden floor)
- rattle (like shaking a baby rattle)
- knock (like a knock at the door)
- tick (like a clock second hand)
- thump (heavy, muffled knock noise)
- buzz (like a bumble bee)

### TO BE COMPLETED BY DEALERSHIP PERSONNEL

#### Test Drive Notes:

---

---

---

	YES	NO	Initials of person performing
Vehicle test driven with customer	<input type="checkbox"/>	<input type="checkbox"/>	_____
- Noise verified on test drive	<input type="checkbox"/>	<input type="checkbox"/>	_____
- Noise source located and repaired	<input type="checkbox"/>	<input type="checkbox"/>	_____
- Follow up test drive performed to confirm repair	<input type="checkbox"/>	<input type="checkbox"/>	_____

VIN: \_\_\_\_\_ Customer Name: \_\_\_\_\_  
W.O.# \_\_\_\_\_ Date: \_\_\_\_\_

This form must be attached to Work Order

PIIB8742E

A  
B  
C  
D  
E  
F  
G  
H  
I  
INT  
K  
L  
M  
N  
O  
P

# PRECAUTIONS

< PRECAUTION >

## PRECAUTION

### PRECAUTIONS FOR MEXICO

#### FOR MEXICO : Precaution for Supplemental Restraint System (SRS) "AIR BAG" and "SEAT BELT PRE-TENSIONER"

INFOID:000000006201282

The Supplemental Restraint System such as "AIR BAG" and "SEAT BELT PRE-TENSIONER", used along with a front seat belt, helps to reduce the risk or severity of injury to the driver and front passenger for certain types of collision. Information necessary to service the system safely is included in the "SRS AIR BAG" and "SEAT BELT" of this Service Manual.

#### **WARNING:**

- To avoid rendering the SRS inoperative, which could increase the risk of personal injury or death in the event of a collision which would result in air bag inflation, all maintenance must be performed by an authorized NISSAN/INFINITI dealer.
- Improper maintenance, including incorrect removal and installation of the SRS, can lead to personal injury caused by unintentional activation of the system. For removal of Spiral Cable and Air Bag Module, see "SRS AIR BAG".
- Never use electrical test equipment on any circuit related to the SRS unless instructed to in this Service Manual. SRS wiring harnesses can be identified by yellow and/or orange harnesses or harness connectors.

#### PRECAUTIONS WHEN USING POWER TOOLS (AIR OR ELECTRIC) AND HAMMERS

#### **WARNING:**

- When working near the Air Bag Diagnosis Sensor Unit or other Air Bag System sensors with the ignition ON or engine running, never use air or electric power tools or strike near the sensor(s) with a hammer. Heavy vibration could activate the sensor(s) and deploy the air bag(s), possibly causing serious injury.
- When using air or electric power tools or hammers, always switch the ignition OFF, disconnect the battery, and wait at least 3 minutes before performing any service.

#### FOR MEXICO : Precaution Necessary for Steering Wheel Rotation After Battery Disconnect

INFOID:000000006201283

#### **NOTE:**

- This Procedure is applied only to models with Intelligent Key system and NVIS/IVIS (NISSAN/INFINITI VEHICLE IMMOBILIZER SYSTEM - NATS).
- Remove and install all control units after disconnecting both battery cables with the ignition switch in the "LOCK" position.
- Always use CONSULT-III to perform self-diagnosis as a part of each function inspection after finishing work. If DTC is detected, perform trouble diagnosis according to self-diagnostic results.

For models equipped with the Intelligent Key system and NVIS/IVIS, an electrically controlled steering lock mechanism is adopted on the key cylinder.

For this reason, if the battery is disconnected or if the battery is discharged, the steering wheel will lock and steering wheel rotation will become impossible.

If steering wheel rotation is required when battery power is interrupted, follow the procedure below before starting the repair operation.

#### OPERATION PROCEDURE

1. Connect both battery cables.

#### **NOTE:**

Supply power using jumper cables if battery is discharged.

2. Use the Intelligent Key or mechanical key to turn the ignition switch to the "ACC" position. At this time, the steering lock will be released.
3. Disconnect both battery cables. The steering lock will remain released and the steering wheel can be rotated.
4. Perform the necessary repair operation.



# PRECAUTIONS

## < PRECAUTION >

5. When the repair work is completed, return the ignition switch to the "LOCK" position before connecting the battery cables. (At this time, the steering lock mechanism will engage.)
6. Perform a self-diagnosis check of all control units using CONSULT-III.

### FOR MEXICO : Precaution for Work

INFOID:000000006201284

- After removing and installing the opening/closing parts, be sure to carry out fitting adjustments to check their operation.
- Check the lubrication level, damage, and wear of each part. If necessary, grease or replace it.

### FOR USA AND CANADA

### FOR USA AND CANADA : Precaution for Supplemental Restraint System (SRS) "AIR BAG" and "SEAT BELT PRE-TENSIONER"

INFOID:000000006201285

The Supplemental Restraint System such as "AIR BAG" and "SEAT BELT PRE-TENSIONER", used along with a front seat belt, helps to reduce the risk or severity of injury to the driver and front passenger for certain types of collision. This system includes seat belt switch inputs and dual stage front air bag modules. The SRS system uses the seat belt switches to determine the front air bag deployment, and may only deploy one front air bag, depending on the severity of a collision and whether the front occupants are belted or unbelted. Information necessary to service the system safely is included in the "SRS AIR BAG" and "SEAT BELT" of this Service Manual.

#### **WARNING:**

- **To avoid rendering the SRS inoperative, which could increase the risk of personal injury or death in the event of a collision that would result in air bag inflation, all maintenance must be performed by an authorized NISSAN/INFINITI dealer.**
- **Improper maintenance, including incorrect removal and installation of the SRS, can lead to personal injury caused by unintentional activation of the system. For removal of Spiral Cable and Air Bag Module, see "SRS AIR BAG".**
- **Never use electrical test equipment on any circuit related to the SRS unless instructed to in this Service Manual. SRS wiring harnesses can be identified by yellow and/or orange harnesses or harness connectors.**

### PRECAUTIONS WHEN USING POWER TOOLS (AIR OR ELECTRIC) AND HAMMERS

#### **WARNING:**

- **When working near the Air Bag Diagnosis Sensor Unit or other Air Bag System sensors with the ignition ON or engine running, never use air or electric power tools or strike near the sensor(s) with a hammer. Heavy vibration could activate the sensor(s) and deploy the air bag(s), possibly causing serious injury.**
- **When using air or electric power tools or hammers, always switch the ignition OFF, disconnect the battery, and wait at least 3 minutes before performing any service.**

### FOR USA AND CANADA : Precaution Necessary for Steering Wheel Rotation After Battery Disconnect

INFOID:000000006201286

#### **NOTE:**

- This Procedure is applied only to models with Intelligent Key system and NVIS/IVIS (NISSAN/INFINITI VEHICLE IMMOBILIZER SYSTEM - NATS).
- Remove and install all control units after disconnecting both battery cables with the ignition switch in the "LOCK" position.
- Always use CONSULT-III to perform self-diagnosis as a part of each function inspection after finishing work. If DTC is detected, perform trouble diagnosis according to self-diagnostic results.

For models equipped with the Intelligent Key system and NVIS/IVIS, an electrically controlled steering lock mechanism is adopted on the key cylinder.

For this reason, if the battery is disconnected or if the battery is discharged, the steering wheel will lock and steering wheel rotation will become impossible.

If steering wheel rotation is required when battery power is interrupted, follow the procedure below before starting the repair operation.

### OPERATION PROCEDURE

1. Connect both battery cables.

#### **NOTE:**

A  
B  
C  
D  
E  
F  
G  
H  
I  
INT  
K  
L  
M  
N  
O  
P

## PRECAUTIONS

### < PRECAUTION >

---

- Supply power using jumper cables if battery is discharged.
2. Use the Intelligent Key or mechanical key to turn the ignition switch to the "ACC" position. At this time, the steering lock will be released.
3. Disconnect both battery cables. The steering lock will remain released and the steering wheel can be rotated.
4. Perform the necessary repair operation.
5. When the repair work is completed, return the ignition switch to the "LOCK" position before connecting the battery cables. (At this time, the steering lock mechanism will engage.)
6. Perform a self-diagnosis check of all control units using CONSULT-III.

### FOR USA AND CANADA : Precaution for Work

INFOID:000000006201287

- After removing and installing the opening/closing parts, be sure to carry out fitting adjustments to check their operation.
- Check the lubrication level, damage, and wear of each part. If necessary, grease or replace it.

# PREPARATION

< PREPARATION >

## PREPARATION

### PREPARATION

#### Special Service Tools

INFOID:000000006201288

The actual shapes of Kent-Moore tools may differ from those of special service tools illustrated here.

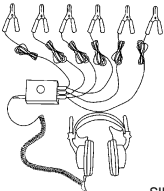
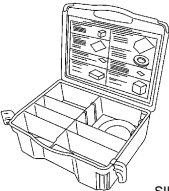
Tool number (Kent-Moore No.) Tool name	Description
(J-39570) Chassis ear   SIIA0993E	Locates the noise
(J-43980) NISSAN Squeak and Rattle Kit   SIIA0994E	Repairs the cause of noise

#### Commercial Service Tools

INFOID:000000006201289

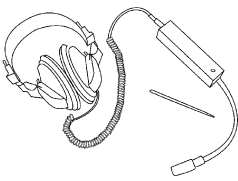
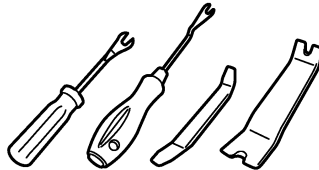
Tool name	Description
Engine ear   SIIA0995E	Locates the noise
Remover tool   JMKIA3050ZZ	Removes clips, pawls and metal clips

# CLIP LIST

< PREPARATION >

## CLIP LIST

### Clip List

INFOID:000000006288774

Shapes	Removal & Installation	Shapes	Removal & Installation
	<p><b>Removal:</b> Remove by bending up with flat-bladed screwdrivers or clip remover.</p>		<p><b>Removal:</b></p>
	<p><b>Removal:</b> Remove with a clip remover.</p>		<p><b>Removal:</b></p>
	<p><b>Removal:</b> Push center pin to catching position. (Do not remove center pin by hitting it.)</p> <p><b>Installation:</b></p>		<p><b>Removal:</b> Holder portion of clip must be spread out to remove rod.</p>
	<p><b>Removal:</b> Remove by bending up with flat-bladed screwdrivers or clip remover.</p>		<p><b>Removal:</b></p> <ol style="list-style-type: none"> <li>Screw out with a Phillips screwdriver.</li> <li>Remove female portion with flat-bladed screwdriver.</li> </ol>
	<p><b>Removal:</b></p>		<p><b>Removal:</b></p> <p>Rotate 45° to remove.</p> <p><b>Installation:</b></p>
	<p><b>Removal:</b></p>		<p><b>Removal:</b></p>

JMJIA3734GB

# DOOR FINISHER

< REMOVAL AND INSTALLATION >

## REMOVAL AND INSTALLATION

### DOOR FINISHER



### FRONT DOOR FINISHER

### FRONT DOOR FINISHER : Exploded View

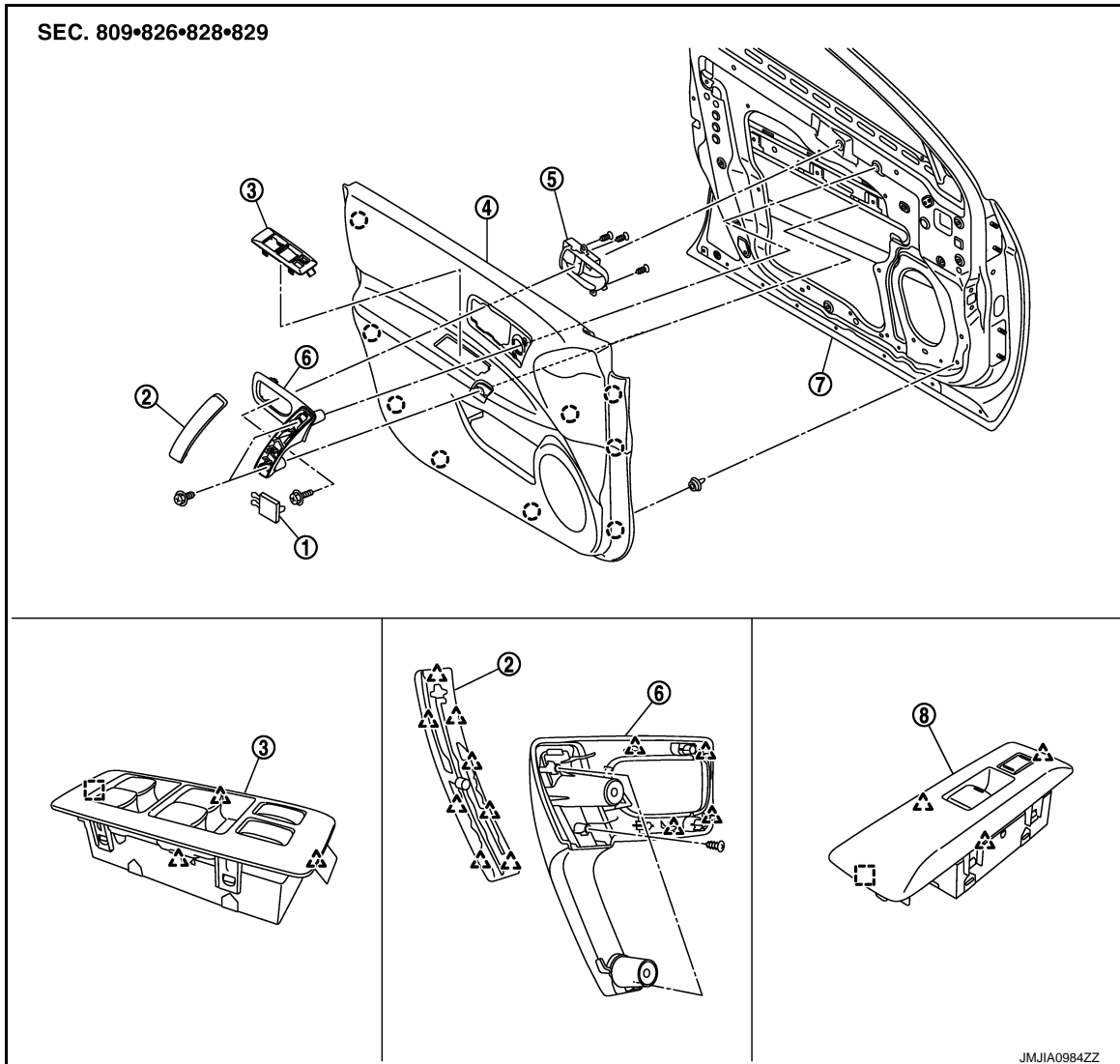
INFOID:000000006201290



- |                            |                                    |                                    |
|----------------------------|------------------------------------|------------------------------------|
| 1. Front door finisher cap | 2. Front door grip cap (LH)        | 3. Power window switch finisher LH |
| 4. Front door finisher     | 5. Front door inside handle        | 6. Front door grip                 |
| 7. Front door panel        | 8. Power window switch finisher RH |                                    |

-  : Clip
-  : Pawl
-  : Metal clip

### FRONT DOOR FINISHER : Removal and Installation

INFOID:000000006201291

#### CAUTION:

- Wrap the tip of flat-bladed screwdriver with a cloth before removal.
- When removing, always use a remover tool that is made of plastic.

#### REMOVAL

A  
B  
C  
D  
E  
F  
G  
H  
I  
INT  
K  
L  
M  
N  
O  
P

# DOOR FINISHER

## < REMOVAL AND INSTALLATION >

1. Fully open front door window.
2. Remove front door finisher cap (1) with wrapped flat-bladed screwdriver (A).

 : Pawl

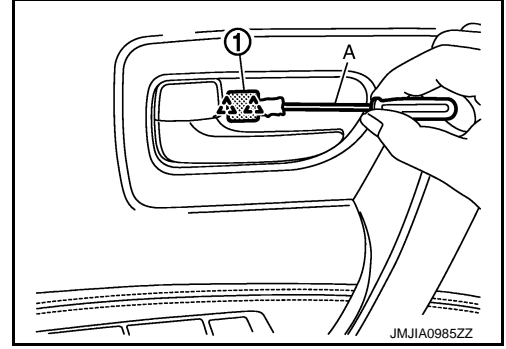

3. Remove bolt (A) located on the back side of door finisher cap using a socket wrench (B).

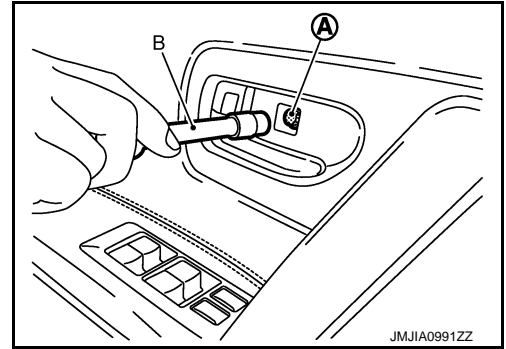

4. Insert a remover tool (A) at the bottom edge of front door grip cap (1) to remove the front door grip cap.

 : Pawl

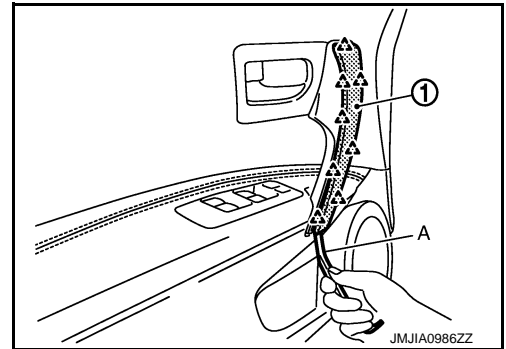

5. Remove both screws (A) holding front door grip in place.

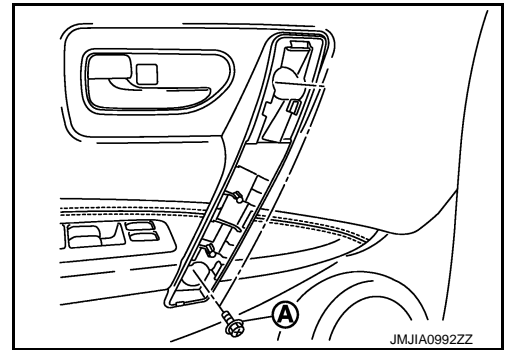

# DOOR FINISHER

## < REMOVAL AND INSTALLATION >

6. Pull up power window switch finisher (1) with remover tool (A).

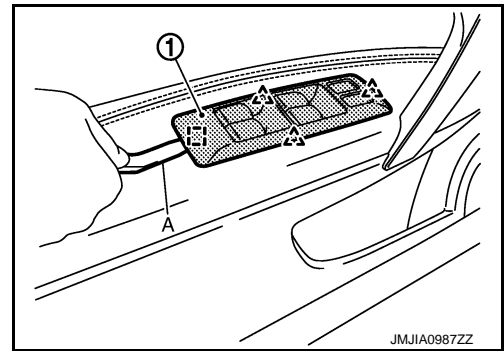
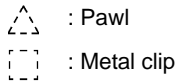

7. Disconnect power window switch connector, and then remove power window switch finisher.  
8. Insert remover tool (A) between door finisher and door panel to disengage door finisher mounting clips, starting from the bottom and working to the top.

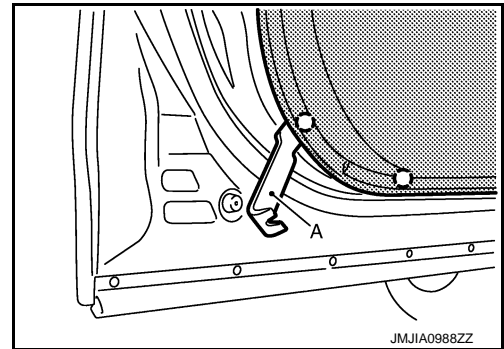
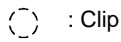

9. Pull up front door finisher and pull out.  
10. Disconnect lock knob cable (1) and inside handle cable (2) from front door inside handle (3).

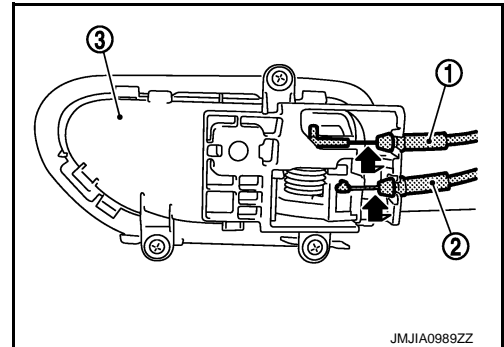

11. Remove front door finisher.  
12. Remove the following parts after removing front door finisher.  
• Inside handle. Refer to [DLK-255, "INSIDE HANDLE : Exploded View"](#).  
• Front door grip.

## INSTALLATION

Install in the reverse order of removal.

### CAUTION:

**When installing door finisher, check that clips are securely fitted in panel holes on body, and then press them in.**

## REAR DOOR FINISHER

A  
B  
C  
D  
E  
F  
G  
H  
I  
INT  
K  
L  
M  
N  
O  
P

# DOOR FINISHER

< REMOVAL AND INSTALLATION >

## REAR DOOR FINISHER : Exploded View

INFOID:000000006201292

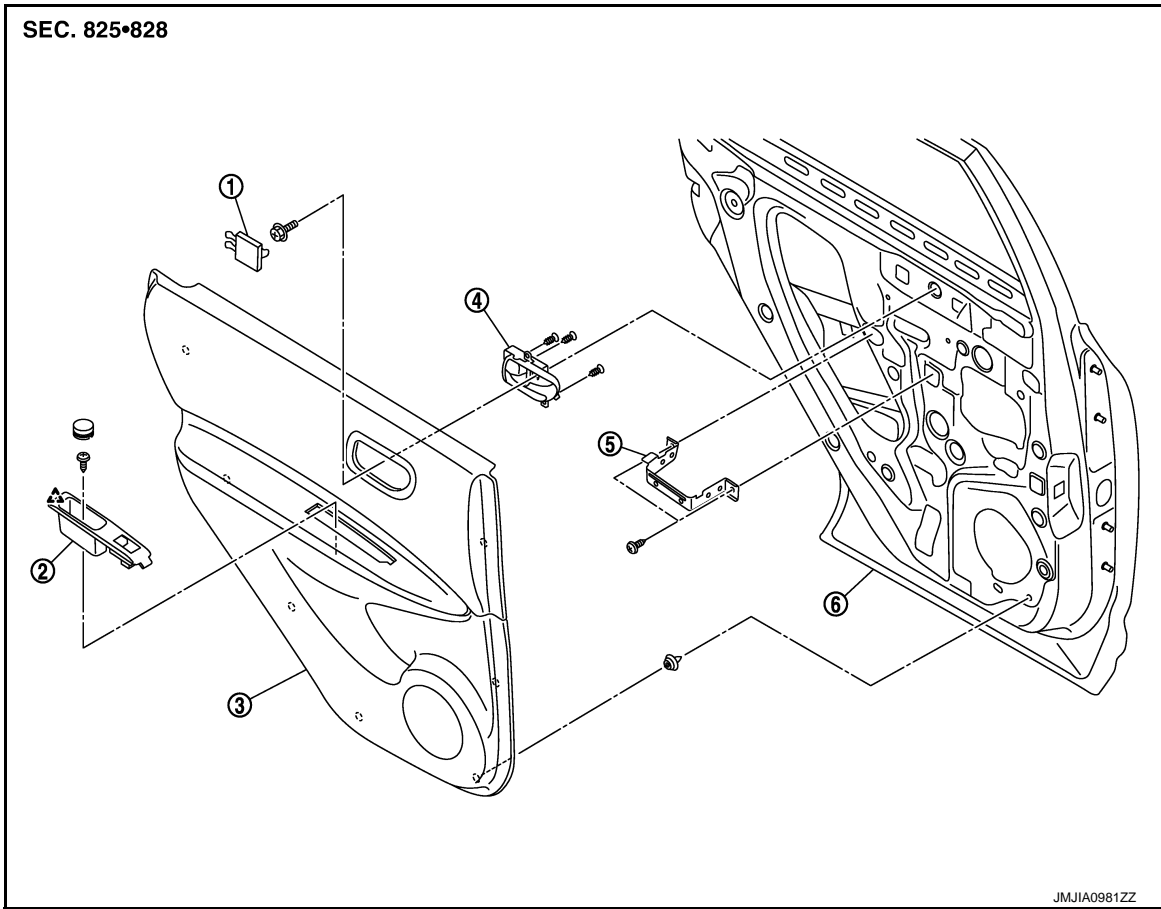

- |                            |                                 |                       |
|----------------------------|---------------------------------|-----------------------|
| 1. Rear door finisher cap  | 2. Power window switch finisher | 3. Rear door finisher |
| 4. Rear door inside handle | 5. Pull handle bracket          | 6. Rear door panel    |

- : Clip  
△ : Pawl

## REAR DOOR FINISHER : Removal and Installation

INFOID:000000006201293

### CAUTION:

- Wrap the tip of flat-bladed screwdriver with a cloth before removal.
- When removing, always use a remover tool that is made of plastic.

### REMOVAL

1. Fully open rear door window.
2. Remove rear door finisher cap (1).

- △ : Pawl

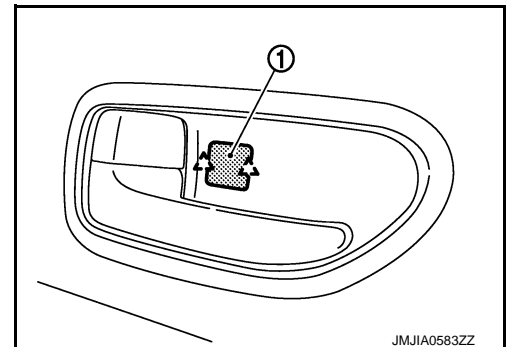



# DOOR FINISHER

## < REMOVAL AND INSTALLATION >

3. Remove bolt (A) located on the back side of door finisher cap using socket wrench (B).

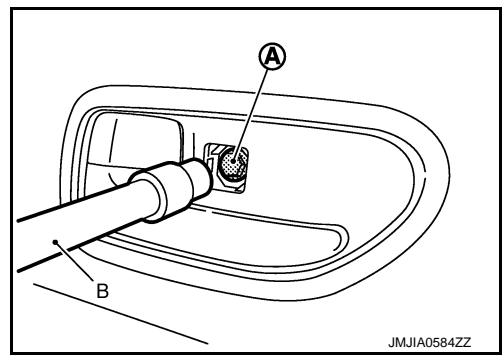

4. Remove screw cap (1) with wrapped flat-bladed screwdriver (A).

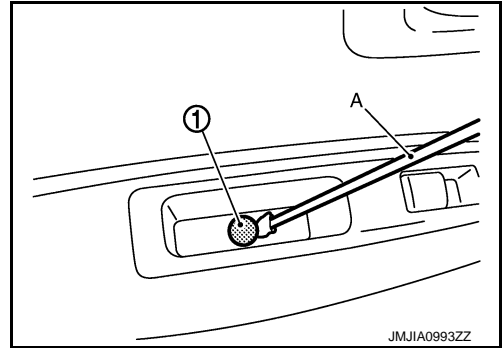

5. Remove TORX screw (A) with tool (B).

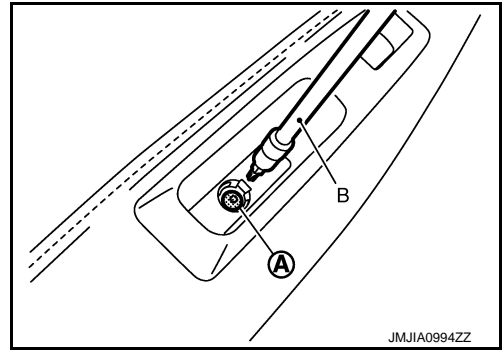

6. Pull up power window switch finisher (1) with remover tool (A).

 : Pawl

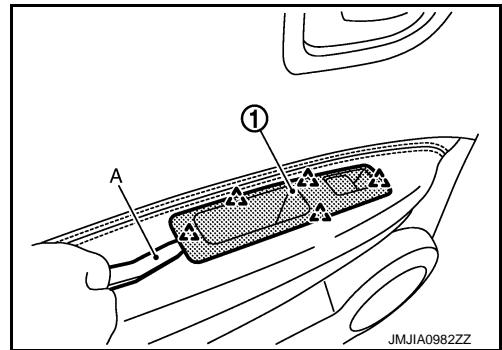

7. Disconnect power window switch connector, and then remove power window switch finisher.

A  
B  
C  
D  
E  
F  
G  
H  
I  
INT  
K  
L  
M  
N  
O  
P

# DOOR FINISHER

## < REMOVAL AND INSTALLATION >

8. Insert remover tool (A) between door finisher and door panel to disengage door finisher mounting clips, starting from the bottom and working to the top.

 : Clip

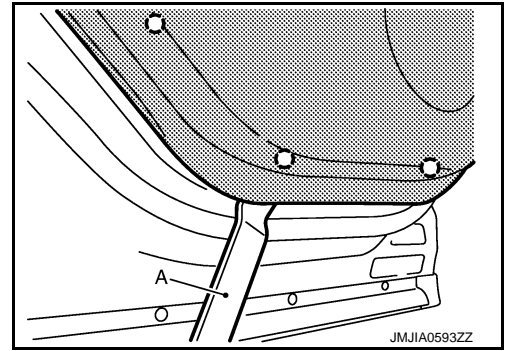

9. Pull up rear door finisher and pull out.
10. Disconnect lock knob cable (1) and inside handle cable (2) from rear door inside handle (3).

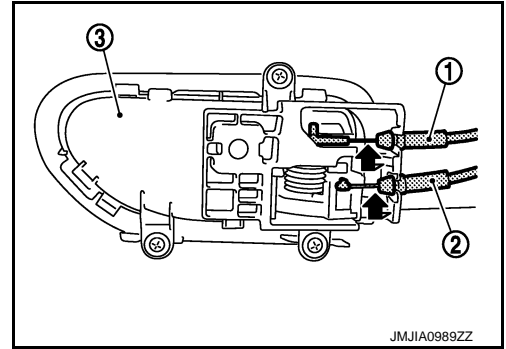

11. Remove rear door finisher.
12. Remove the following parts after removing rear door finisher.
  - Rear door inside handle. Refer to [DLK-261, "INSIDE HANDLE : Exploded View"](#).
  - Pull handle bracket

## INSTALLATION

Install in the reverse order of removal.

### **CAUTION:**

**When installing door finisher, check that clips are securely fitted in panel holes on body, and then press them in.**

# BODY SIDE TRIM

< REMOVAL AND INSTALLATION >

## BODY SIDE TRIM

Exploded View

INFOID:000000006201294

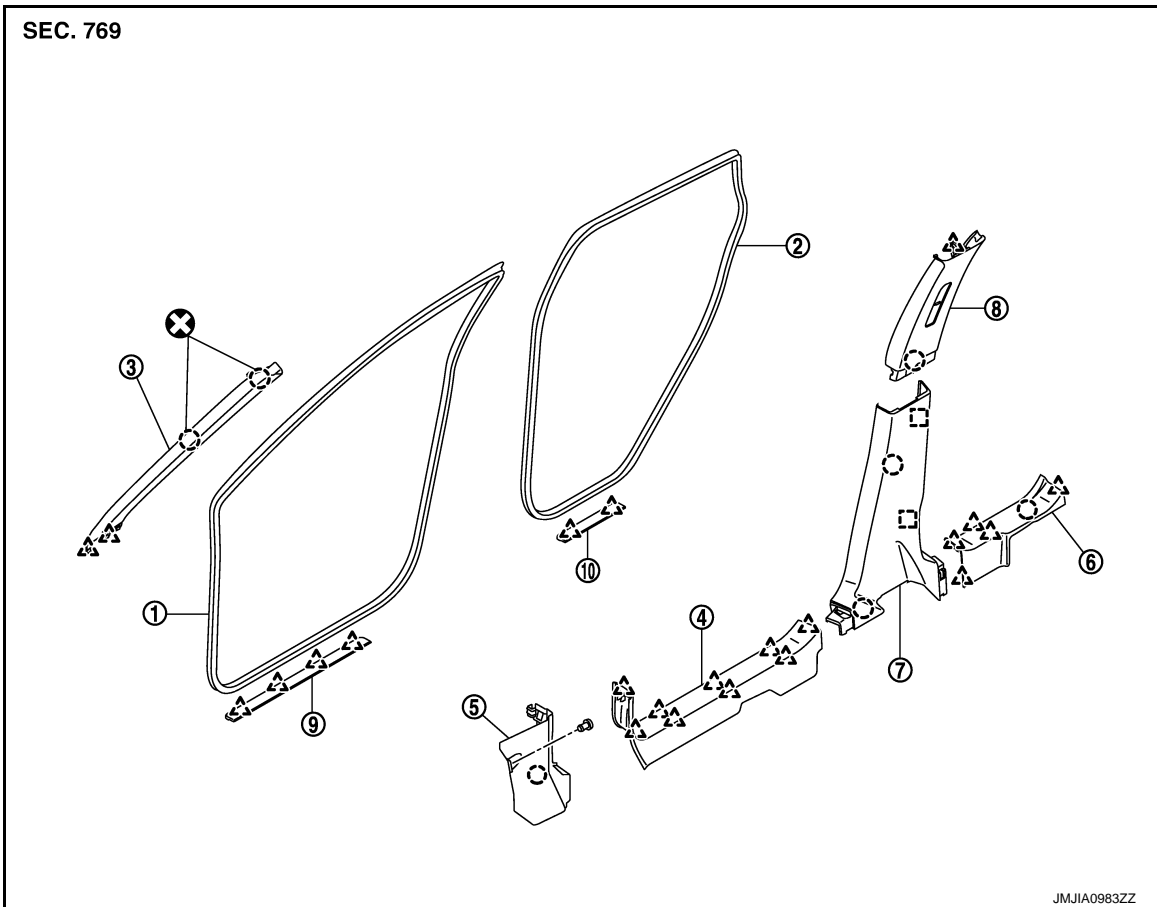

- |                                |                                |                                |
|--------------------------------|--------------------------------|--------------------------------|
| 1. Front body side welt        | 2. Rear body side welt         | 3. Front pillar garnish        |
| 4. Front kicking plate (inner) | 5. Dash side finisher          | 6. Rear kicking plate (inner)  |
| 7. Center pillar lower garnish | 8. Center pillar upper garnish | 9. Front kicking plate (outer) |
| 10. Rear kicking plate (outer) |                                |                                |

○ : Clip

△ : Pawl

□ : Metal clip

Refer to [GI-3, "Contents"](#) for symbols in the figure.

### Removal and Installation

INFOID:000000006201295

#### CAUTION:

- Wrap the tip of flat-bladed screwdriver with a cloth when removing metal clips from garnishes.
- When removing, always use a remover tool that is made of plastic.

#### REMOVAL

##### FRONT PILLAR GARNISH

1. Remove front body side welt partially.

A  
B  
C  
D  
E  
F  
G  
H  
I  
INT  
K  
L  
M  
N  
O  
P

## BODY SIDE TRIM

### < REMOVAL AND INSTALLATION >

2. Disengage front pillar garnish (1) fixing clip using remover tool (A).

 : Clip

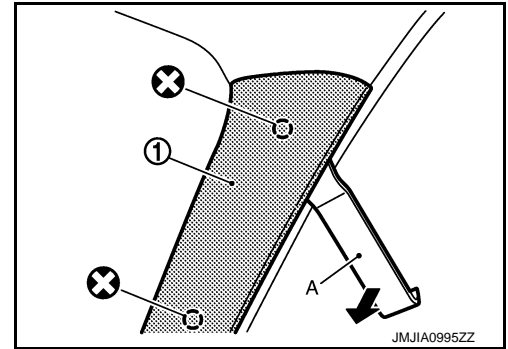

3. Pull the front pillar garnish partially toward the vehicle.
4. Insert the remover tool (A) between the front pillar garnish bottom side and body side to disengage the clip.

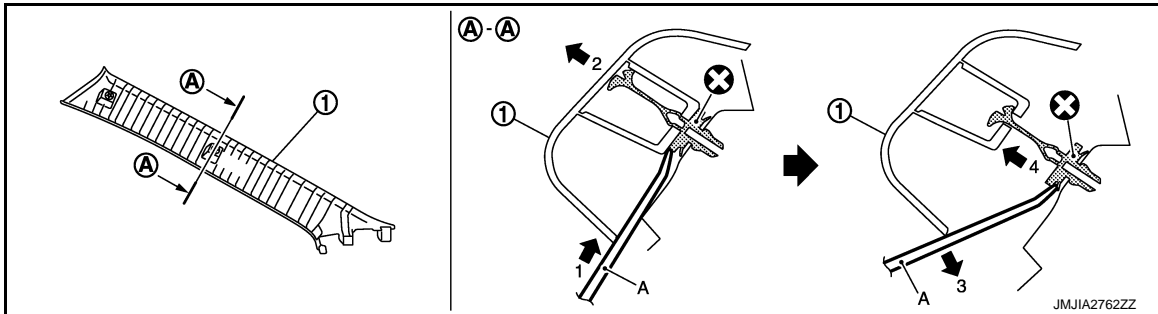

5. Once free, pull front pillar garnish upwards and use a cutter knife to cut both clips.
6. Remove front pillar garnish (1).

### FRONT KICKING PLATE INNER

1. Disengage the pawls with remover tool (A) from the body.
2. Remove front kicking plate inner (1).

 : Pawl

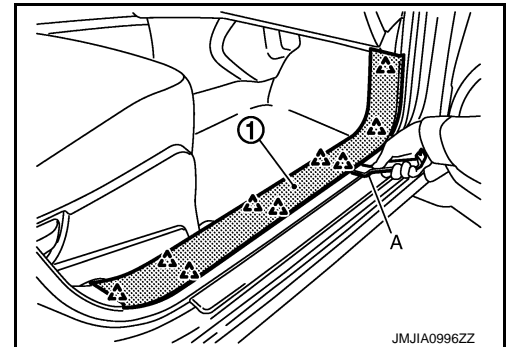

### FRONT KICKING PLATE OUTER

1. Disengage the pawls from the body with remover tool (A).
2. Remove front kicking plate outer (1)

 : Pawl

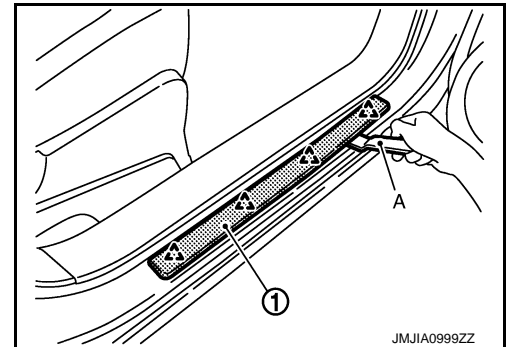

### DASH SIDE FINISHER

1. Remove front kicking plate inner.
2. Remove dash side finisher fixing nut.

## BODY SIDE TRIM

### < REMOVAL AND INSTALLATION >

3. Disengage dash side finisher (1) mounting clip using remover tool (A).
4. Remove dash side finisher.

○ : Clip

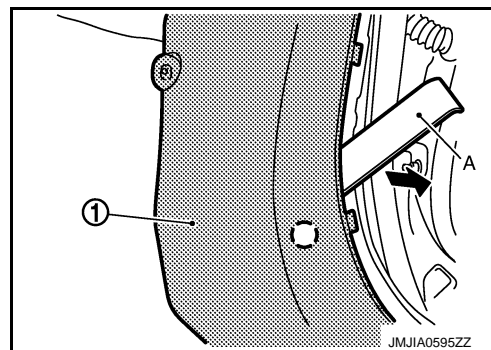

### REAR KICKING PLATE INNER

1. Disengage the pawls and clip from the body with remover tool (A).
2. Remove rear kicking plate inner (1).

○ : Clip

△ : Pawl

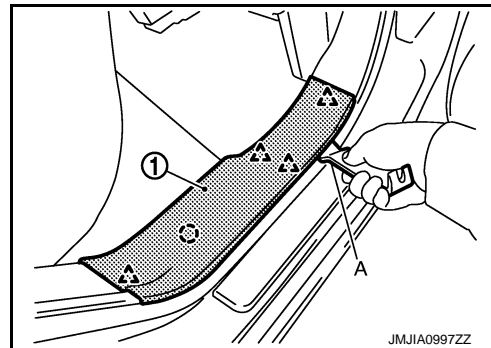

### REAR KICKING PLATE OUTER

1. Disengage the pawls from the body with remover tool (A).
2. Remove rear kicking plate outer (1).

△ : Pawl

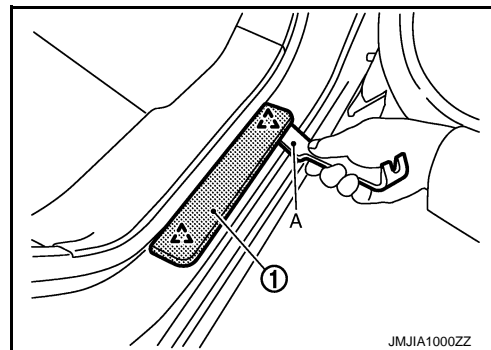

### CENTER PILLAR LOWER GARNISH

1. Remove front kicking plate inner and rear kicking plate inner.
2. Insert remover tool (A) between center pillar lower garnish (1) and body side panel to disengage clips.
3. Remove center pillar lower garnish.

○ : Clip

□ : Metal clip

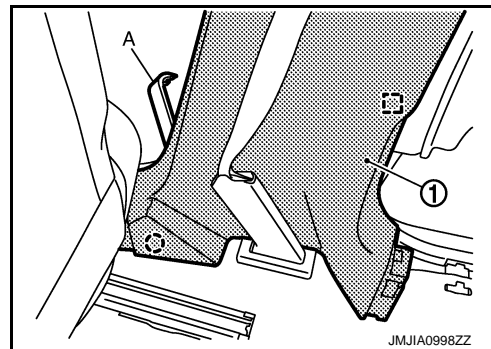

### CENTER PILLAR UPPER GARNISH

1. Remove partially front and rear body side welt.
2. Remove front kicking plate inner and rear kicking plate inner.
3. Remove center pillar lower garnish.

A  
B  
C  
D  
E  
F  
G  
H  
I  
INT  
K  
L  
M  
N  
O  
P

## BODY SIDE TRIM

### < REMOVAL AND INSTALLATION >

4. Remove front seat belt shoulder anchor. Refer to [SB-7. "SEAT BELT RETRACTOR : Removal and Installation"](#).
5. Pull center pillar upper garnish from inside passenger room, disengage clips as shown in the figure, and remove garnish from vehicle.

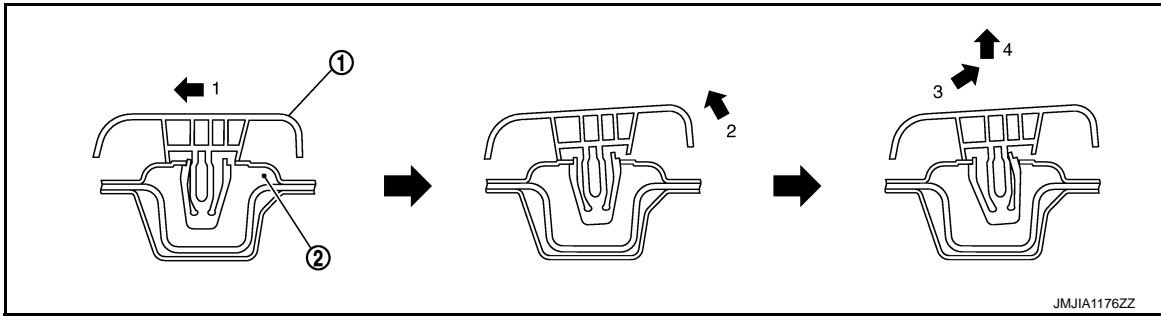

1. Center pillar upper garnish

2. Center pillar panel

### INSTALLATION

Install in the reverse order of removal.

#### **CAUTION:**

**When installing body side trim, check that clips are securely fitted in panel holes on body, and then press them in.**

# FLOOR TRIM

< REMOVAL AND INSTALLATION >

## FLOOR TRIM

Exploded View

INFOID:000000006201296

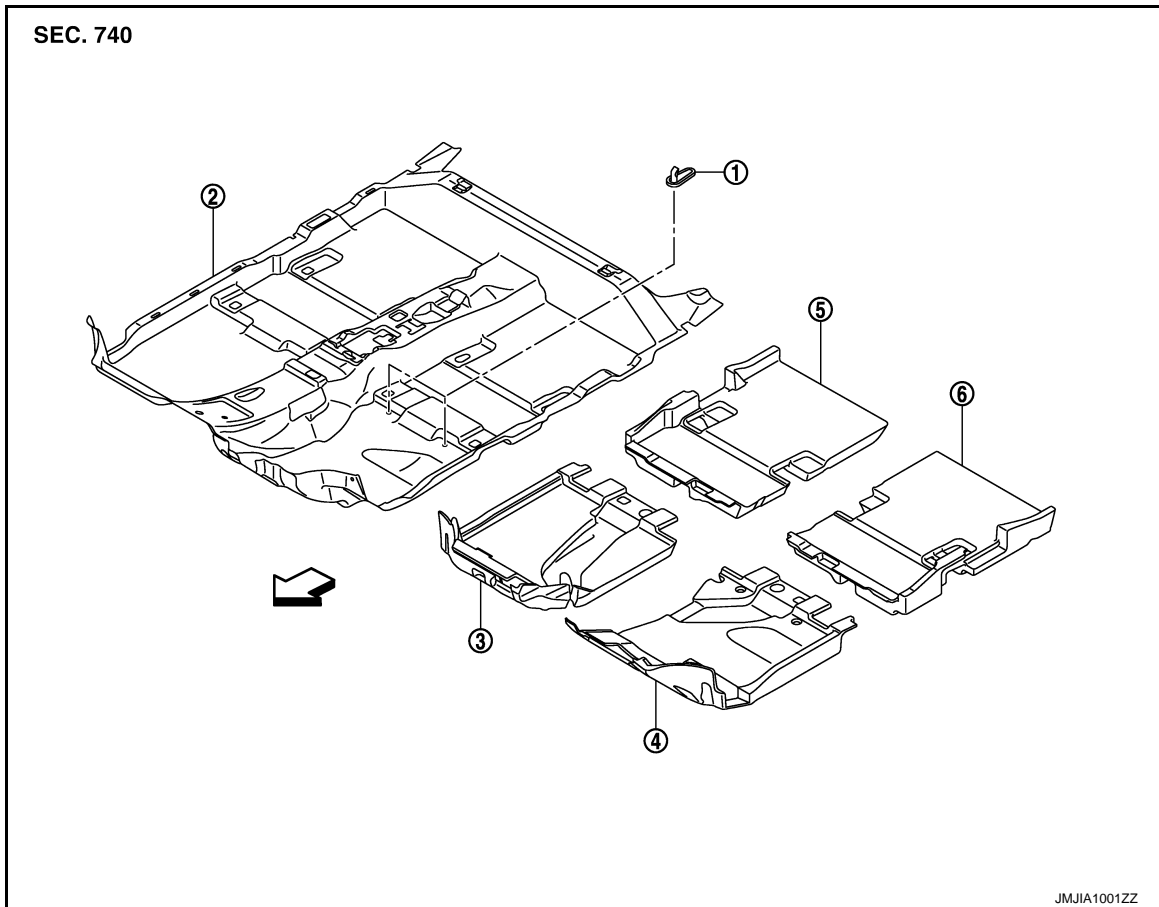

- |                          |                          |                          |
|--------------------------|--------------------------|--------------------------|
| 1. Floor hook            | 2. Floor carpet assembly | 3. Front floor spacer RH |
| 4. Front floor spacer LH | 5. Rear floor spacer RH  | 6. Rear floor spacer LH  |

↔ : Vehicle front

## Removal and Installation

INFOID:000000006201297

### REMOVAL

1. Remove front seat assembly (LH/RH). Refer to [SE-30, "Removal and Installation"](#).
2. Remove rear seat cushion assembly. Refer to [SE-38, "Removal and Installation"](#).
3. Remove dash side finisher (LH/RH), front kicking plate inner (LH/RH), center pillar lower garnish (LH/RH), and rear kicking plate inner. Refer to [INT-19, "Removal and Installation"](#).
4. Remove center console assembly. Refer to [IP-22, "Removal and Installation"](#).
5. Remove console bracket mounting nuts (A), and then remove console bracket LH (1).
6. Remove front foot duct LH (2) (with rear foot duct). Refer to [VTL-14, "FRONT FOOT DUCT : Removal and Installation"](#).

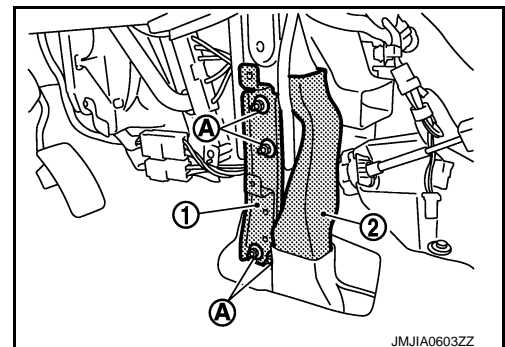

# FLOOR TRIM

## < REMOVAL AND INSTALLATION >

7. Remove screw (A), and then remove front foot duct RH (1) (with rear foot duct model).  
Refer to [VTL-15. "REAR FOOT DUCT 1 : Removal and Installation"](#).

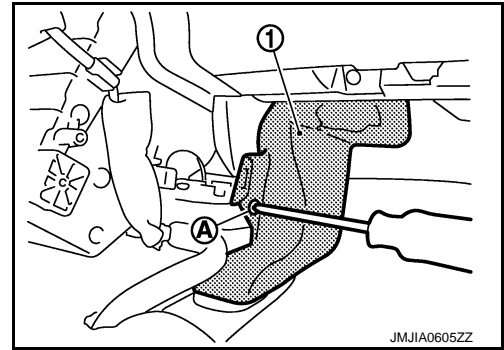

8. Disconnect harness connectors (A).  
Remove floor harness mounting clips (B).

 : Clip

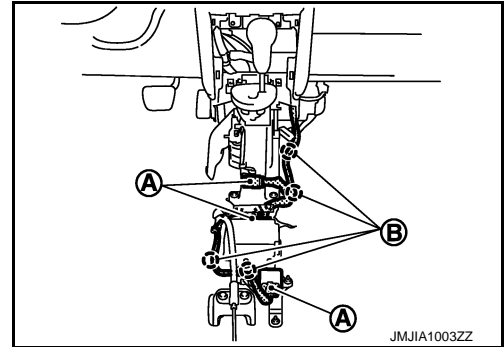

9. Remove CVT shift selector assembly.  
Without manual mode: Refer to [TM-175. "WITHOUT MANUAL MODE : Removal and Installation"](#).  
With manual mode: Refer to [TM-178. "WITH MANUAL MODE : Removal and Installation"](#).
10. Remove parking brake control cable. Refer to [PB-6. "Removal and Installation"](#).
11. Remove diagnosis sensor unit. Refer to [SR-24. "Removal and Installation"](#).
12. Remove floor carpet from fixing clips (A), and then remove floor carpet.

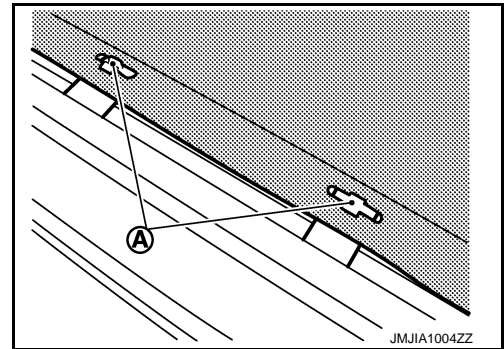

13. Remove the following part after removing floor carpet.
- Floor hooks (1) with remover tool (A).
  - Front floor spacer (LH/RH)
  - Rear floor spacer (LH/RH)

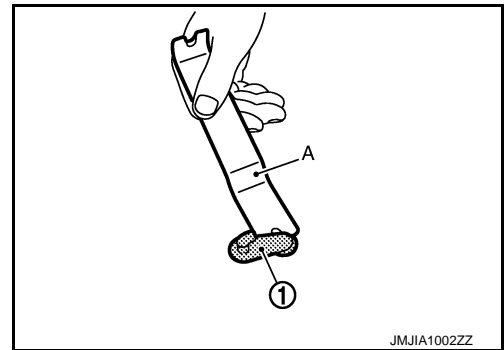

## INSTALLATION

Install in the reverse order of removal.



# HEADLINING

< REMOVAL AND INSTALLATION >

## HEADLINING NORMAL ROOF

### NORMAL ROOF : Exploded View

INFOID:000000006201298

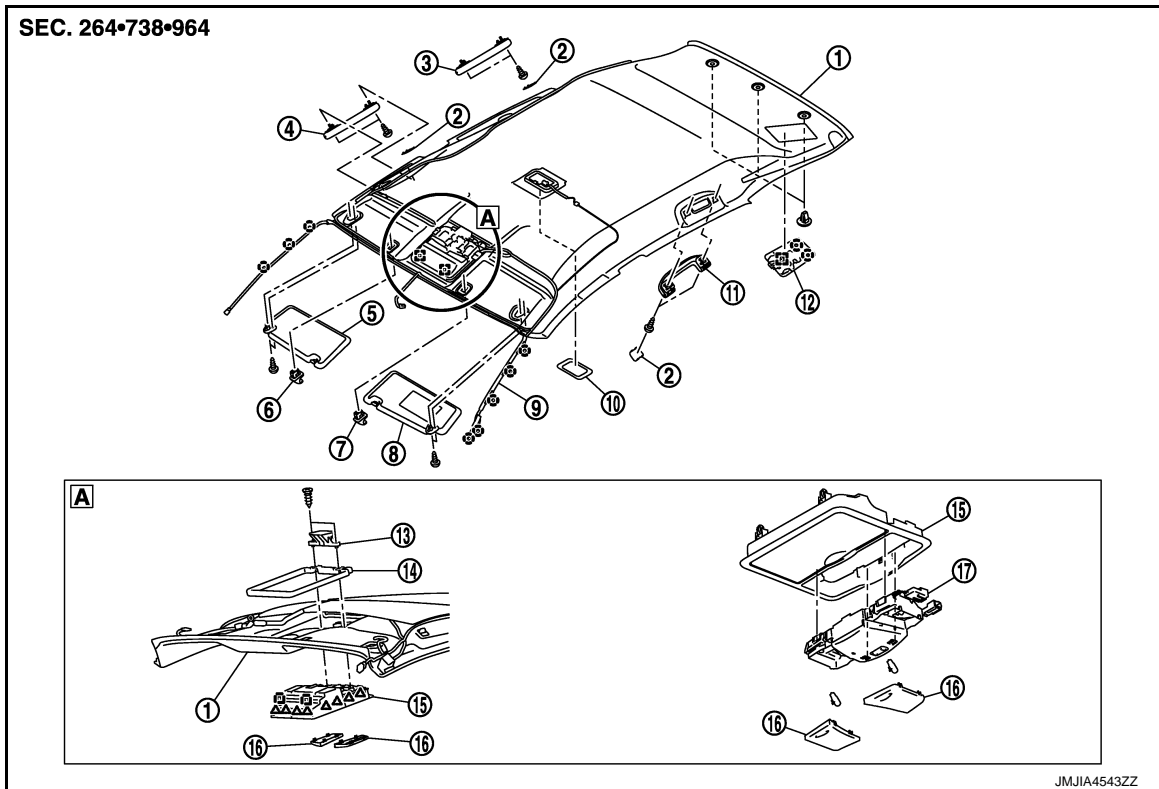

JMJIA4543ZZ

- |                         |                         |                                 |
|-------------------------|-------------------------|---------------------------------|
| 1. Headlining assembly  | 2. Assist grip cap      | 3. Rear assist grip RH          |
| 4. Front assist grip RH | 5. Sun-visor RH         | 6. Sun-visor holder RH          |
| 7. Sun-visor holder LH  | 8. Sun-visor LH         | 9. Roof harness                 |
| 10. Room lamp           | 11. Rear assist grip LH | 12. Rear center seat belt cover |
| 13. Map lamp bracket    | 14. Roof plate assembly | 15. Roof console assembly       |
| 16. Map lamp lens       | 17. Map lamp assembly   |                                 |

 : Clip

 : Pawl

 : Metal clip

### NORMAL ROOF : Removal and Installation

INFOID:000000006201299

#### REMOVAL

1. Remove rear seat cushion and seat back. Refer to [SE-38, "Removal and Installation"](#).
2. Remove rear seat belt anchor bolt (LH/RH). Refer to [SB-12, "SEAT BELT RETRACTOR : Exploded View"](#).
3. Remove front seat belt anchor bolt (LH/RH). Refer to [SB-7, "SEAT BELT RETRACTOR : Exploded View"](#).
4. Remove luggage side lower finisher (LH/RH), luggage side upper finisher (LH/RH). Refer to [INT-33, "Removal and Installation"](#).
5. Remove front pillar garnish (LH/RH), front kicking plate (LH/RH), center pillar lower garnish (LH/RH), center pillar upper garnish (LH/RH), front body side welt (LH/RH), rear body side welt (LH/RH), rear kicking plate (LH/RH). Refer to [INT-19, "Removal and Installation"](#).

# HEADLINING

## < REMOVAL AND INSTALLATION >

6. Disconnect roof harness connectors (A) (LH/RH).
7. Remove harness clips (B) of roof harness (1) (LH/RH).

 : Clip

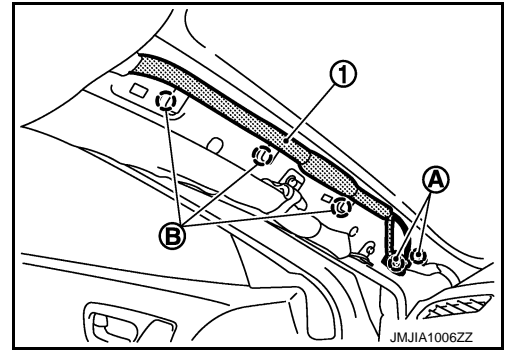

8. Remove sun-visor (LH/RH).
  - Remove mounting screws.
  - Disconnect vanity mirror lamp harness connector. (with Vanity mirror lamp)
9. Rotate 45 degrees and remove sun-visor holder (1) (LH/RH).

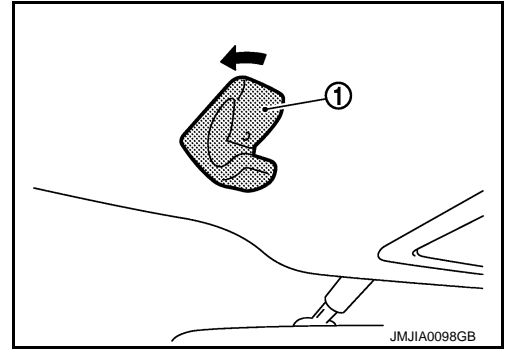

10. Remove front assist grip and rear assist grip (2).
  - Remove assist grip cap (1).
  - Remove assist grip mounting bolts (A).

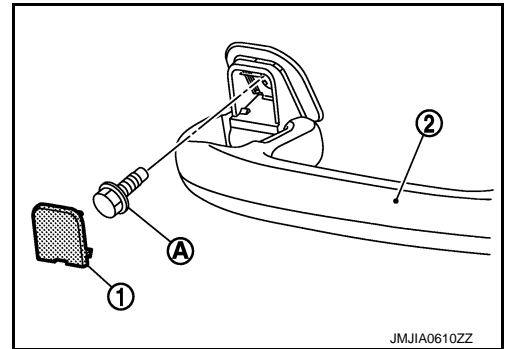

- Remove assist grip (1) with remover tool (A) and then pull back assist grip.

 : Pawl

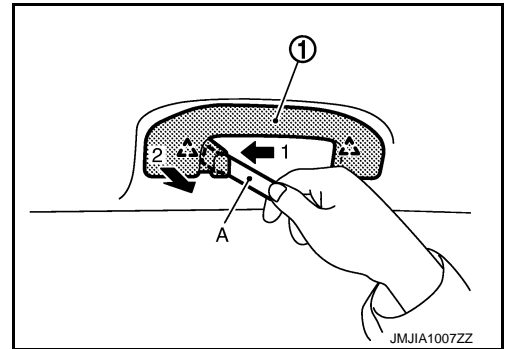

11. Recline front seat back to facilitate the headlining removal.

# HEADLINING

## < REMOVAL AND INSTALLATION >

12. Pull roof console assembly toward vehicle lower, and disengage dual-lock fastener (A) and metal clips (B).

**CAUTION:**

Roof console assembly is crimped from back of headlining. Remove it by disengaging the crimped area of back of roof console assembly after removing headlining from the vehicle.

 : Metal clip

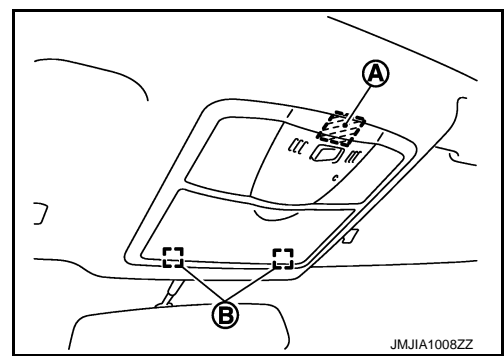

13. Disengage rear center seat belt cover clips and metal clip with remover tool (A), then remove rear center seat belt cover (1).

 : Clip

 : Metal clip

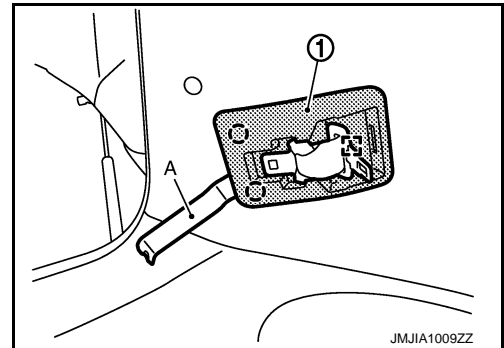

14. Using remover tool, remove headlining clips at the back side of headlining.

15. Remove headlining (1) from back door.

**CAUTION:**

- When removing, 2 workers are required.
- Never bend headlining when removing.
- Be careful not to scratch or damage any part of the body while taking out the headlining.

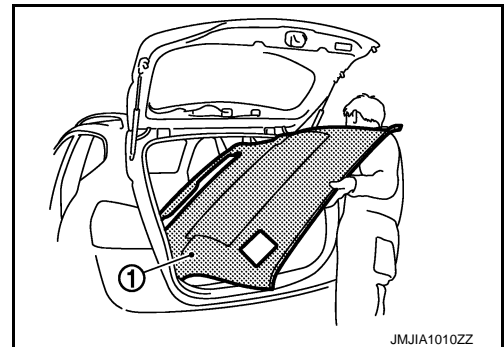

16. Remove the following parts after removing headlining.
- Room lamp assembly. Refer to [INL-70, "Removal and Installation"](#).
  - Roof console assembly.
  - Sunglasses holder assembly.
  - Roof harness assembly.

## INSTALLATION

Install in the reverse order of removal.

**CAUTION:**

- As for guide, install sun-visor holder (LH/RH) then headlining hidden clips at the back side of headlining.
- Be careful not to bend the headlining when installing.

## SUNROOF

A  
B  
C  
D  
E  
F  
G  
H  
I  
INT  
K  
L  
M  
N  
O  
P

# HEADLINING

< REMOVAL AND INSTALLATION >

## SUNROOF : Exploded View

INFOID:000000006201300

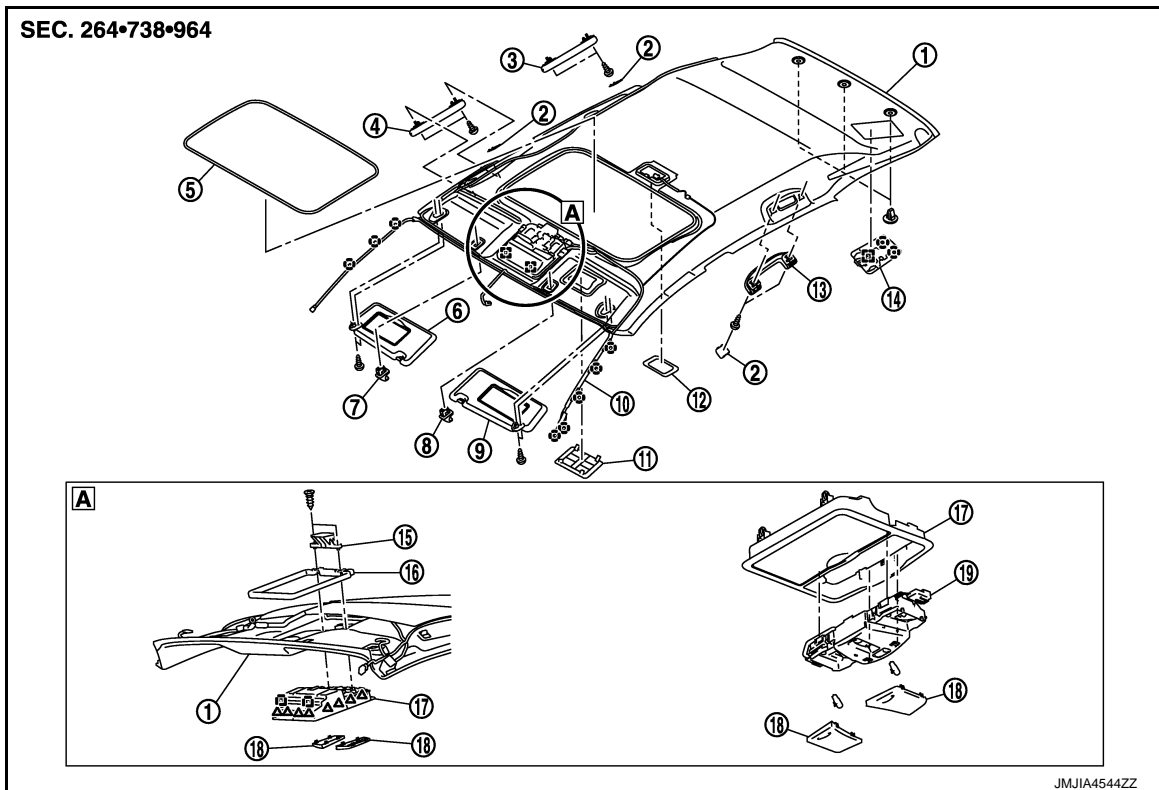

- |                         |                                 |                        |
|-------------------------|---------------------------------|------------------------|
| 1. Headlining assembly  | 2. Assist grip cap              | 3. Rear assist grip RH |
| 4. Front assist grip RH | 5. Sunroof welt                 | 6. Sun-visor RH        |
| 7. Sun-visor holder RH  | 8. Sun-visor holder LH          | 9. Sun-visor LH        |
| 10. Roof harness        | 11. Roof finisher               | 12. Room lamp          |
| 13. Rear assist grip LH | 14. Rear center seat belt cover | 15. Map lamp bracket   |
| 16. Roof plate assembly | 17. Roof console assembly       | 18. Map lamp lens      |
| 19. Map lamp assembly   |                                 |                        |

- : Clip  
△ : Pawl  
□ : Metal clip

## SUNROOF : Removal and Installation

INFOID:000000006201301

### REMOVAL

1. Remove rear seat cushion and seat back. Refer to [SE-38. "Removal and Installation"](#).
2. Remove rear seat belt anchor bolt (LH/RH). Refer to [SB-12. "SEAT BELT RETRACTOR : Exploded View"](#).
3. Remove front seat belt anchor bolt (LH/RH). Refer to [SB-7. "SEAT BELT RETRACTOR : Exploded View"](#).
4. Remove luggage side lower finisher (LH/RH), luggage side upper finisher (LH/RH). Refer to [INT-33. "Removal and Installation"](#).
5. Remove front pillar garnish (LH/RH), front kicking plate inner (LH/RH), center pillar lower garnish (LH/RH), center pillar upper garnish (LH/RH), front body side welt (LH/RH), rear body side welt (LH/RH), rear kicking plate inner (LH/RH). Refer to [INT-19. "Removal and Installation"](#).

# HEADLINING

## < REMOVAL AND INSTALLATION >

6. Disconnect roof harness connectors (A) (LH/RH).
7. Remove harness clips (B) of roof harness (1) (LH/RH).

 : Clip

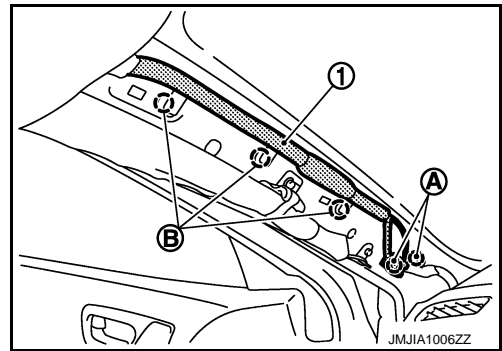

8. Remove roof finisher (1) with remover tool (A).

 : Pawl

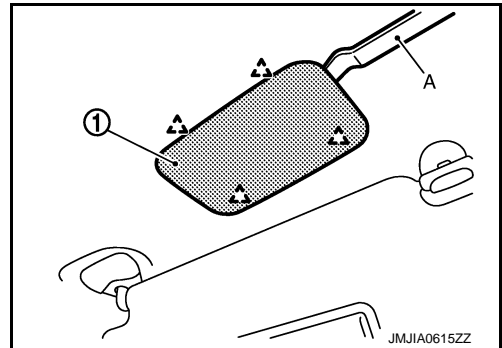

9. Disconnect roof harness connector (A).

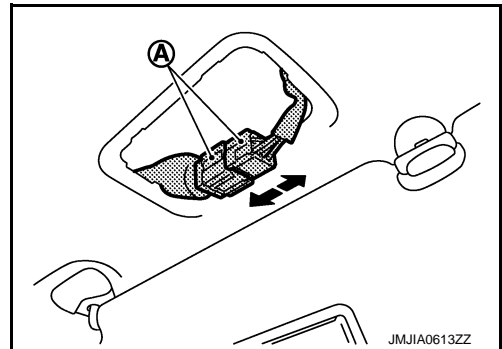

10. Remove sun-visor (LH/RH).
  - Remove mounting screws.
  - Disconnect vanity mirror lamp harness connector. (with Vanity mirror lamp)
11. Rotate 45 degrees and remove sun-visor holder (1) (LH/RH).

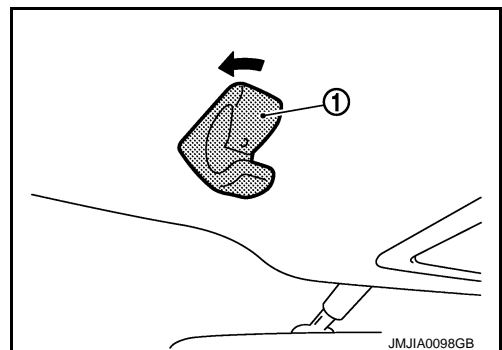

A  
B  
C  
D  
E  
F  
G  
H  
I  
INT  
K  
L  
M  
N  
O  
P

# HEADLINING

## < REMOVAL AND INSTALLATION >

12. Remove front assist grip and rear assist grip (2).

- Remove assist grip cap (1).
- Remove assist grip mounting bolts (A).

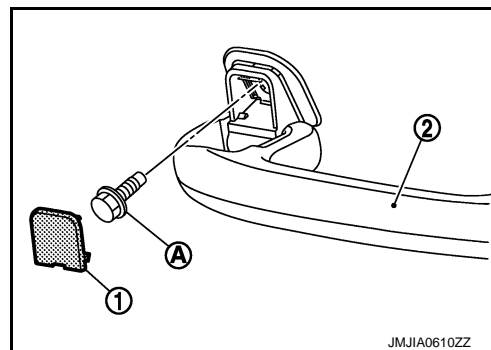

- Remove assist grip (1) with remover tool (A) and then pull back assist grip.

 : Pawl

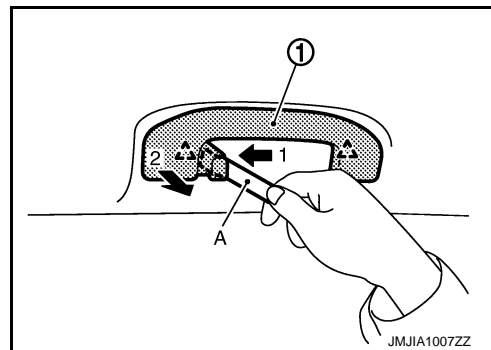

13. Recline front seat back to facilitate the headlining removal.

14. Pull roof console assembly toward vehicle lower, and disengage dual-lock fastener (A) and metal clips (B).

**CAUTION:**

**Roof console assembly is crimped from back of headlining. Remove it by disengaging the crimped area of back of roof console assembly after removing headlining from the vehicle.**

 : Metal clip

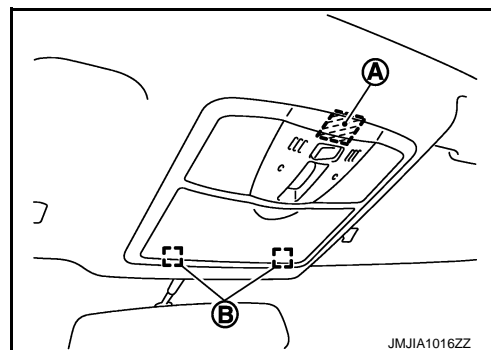

15. Disengage rear center seat belt cover clips and metal clip using remover tool (A), then remove rear center seat belt cover (1).

 : Metal clip

 : Clip

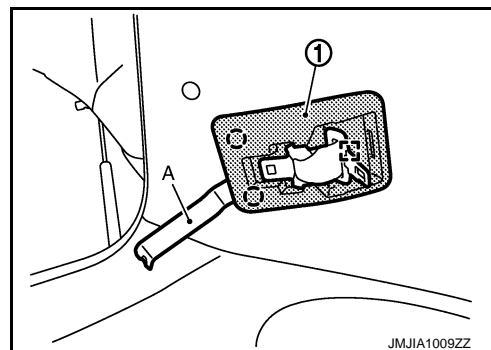

16. Using remover tool, remove headlining clips at the back side of headlining.

# HEADLINING

## < REMOVAL AND INSTALLATION >

17. Remove headlining (1) from back door.

**CAUTION:**

- When removing, 2 workers are required.
- Do not bend headlining when removing.
- Be careful not to scratch or damage any part of the body while taking out the headlining.

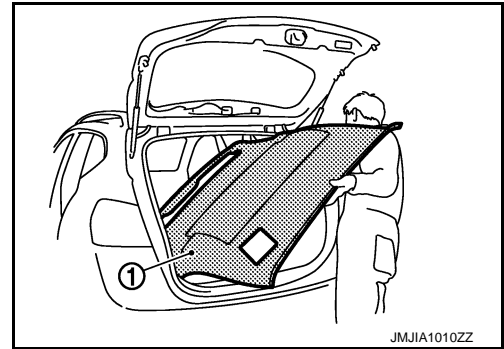

18. Remove the following parts after removing headlining.

- Room lamp assembly. Refer to [INL-70, "Removal and Installation"](#).
- Roof console assembly.
- Sunglasses holder assembly.
- Sunroof welt.
- Roof harness assembly.

## INSTALLATION

Install in the reverse order of removal.

**CAUTION:**

- As for guide, install sun-visor holder (LH/RH) then headlining hidden clips at the back side of headlining.
- Be careful not to bend the headlining when installing.

A  
B  
C  
D  
E  
F  
G  
H  
I  
K  
L  
M  
N  
O  
P

INT

# LUGGAGE FLOOR TRIM

< REMOVAL AND INSTALLATION >

## LUGGAGE FLOOR TRIM

Exploded View

INFOID:00000006201302

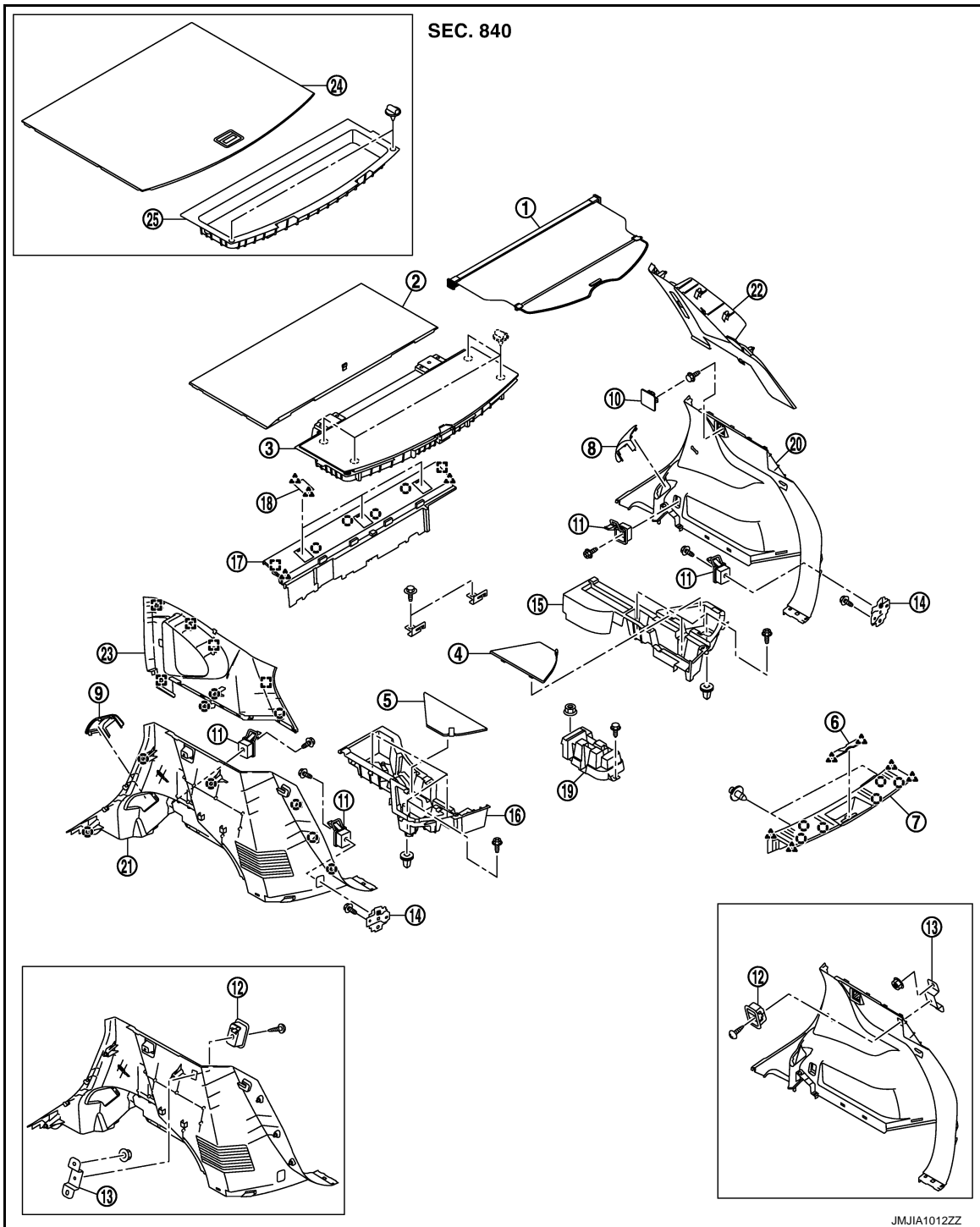

- |                                |  |   |
|--------------------------------|--|---|
| 1. Tonneau cover assembly      | 2. Luggage floor center board (for SL) | 3. Luggage floor box (for SL)             |
| 4. Luggage floor side board RH | 5. Luggage floor side board LH         | 6. Luggage rear plate mask                |
| 7. Luggage rear plate          | 8. Luggage finisher mask RH            | 9. Luggage finisher mask LH               |
| 10. Tonneau cap RH             | 11. Rope hook                          | 12. Rear door hook                        |
| 13. Luggage trim bracket       | 14. Luggage side lower bracket         | 15. Luggage floor spacer assembly (FR/RH) |

JMJIA1012ZZ



# LUGGAGE FLOOR TRIM

## < REMOVAL AND INSTALLATION >

- |   |                                    |  |
|---|------------------------------------|--|
| 16. Luggage floor spacer assembly (FR/LH) | 17. Luggage floor center finisher  | 18. Child anchor cover                 |
| 19. Luggage floor spacer RH               | 20. Luggage side lower finisher RH | 21. Luggage side lower finisher LH     |
| 22. Luggage side upper finisher RH        | 23. Luggage side upper finisher LH | 24. Luggage floor center board (for S) |
| 25. Luggage floor box (for S)             |                                    |  |

 : Clip

 : Pawl

 : Metal clip

## Removal and Installation

INFOID:000000006201303

### REMOVAL

#### LUGGAGE REAR PLATE

1. Fully open back door.
2. Remove tonneau cover assembly (with tonneau cover assembly).
3. Remove luggage floor center board.
4. Turn the clips to disengage luggage floor box, then remove luggage floor box.

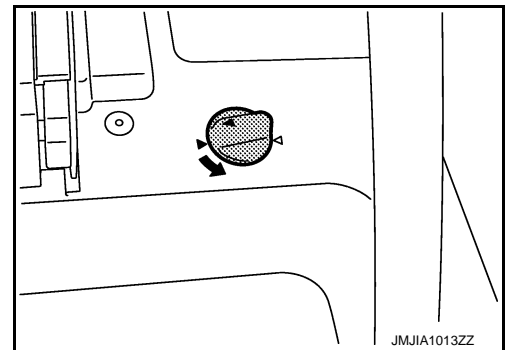

5. Remove back door weather strip. Refer to [DLK-251. "BACK DOOR WEATHER-STRIP : Removal and Installation"](#).
6. Remove luggage rear plate mask with remover tool.
7. Remove luggage rear plate (1) fixing clips with remover tool (B).

 : Clip

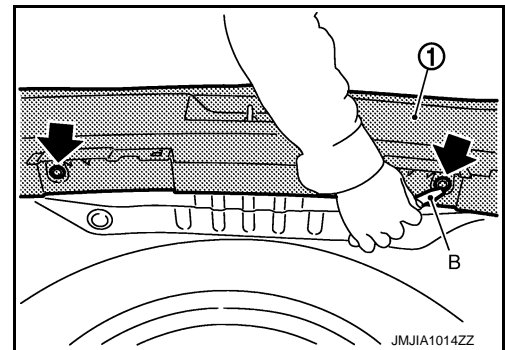

8. Hold both sides of luggage rear plate, pull upwards to remove.

#### LUGGAGE SIDE LOWER FINISHER

1. Remove tonneau cover assembly then remove tonneau cap and bolt (with tonneau cover assembly).
2. Remove rear kicking plate inner and rear body side welt. Refer to [INT-19. "Removal and Installation"](#).
3. Remove rear seat back and rear seat cushion. Refer to [SE-38. "Removal and Installation"](#).
4. Remove luggage floor center board.
5. Remove luggage floor box.
6. Remove luggage rear plate.
7. Remove luggage floor side board.
8. Remove luggage floor spacer assembly (FR).

## LUGGAGE FLOOR TRIM

### < REMOVAL AND INSTALLATION >

9. Remove luggage floor center finisher.
10. Disengage rope hook mounting bolt caps, and remove rope hook mounting bolts with socket wrench (A), and then remove rope hooks (1) (front/rear).

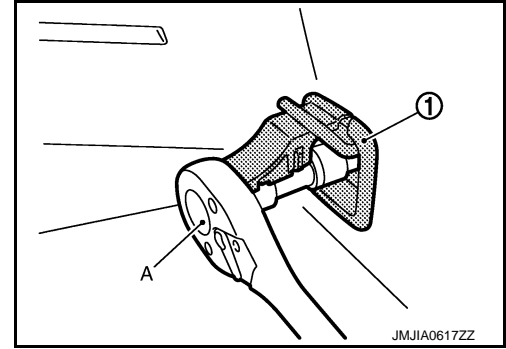

11. Remove rear door hook (with rear door hook).
12. Remove luggage side lower finisher fixing clips and metal clips with remover tool.
13. Remove luggage side lower finisher.

### LUGGAGE SIDE UPPER FINISHER

1. Remove luggage side lower finisher.
2. Remove rear seat belt anchor bolt (upper). Refer to [SB-12. "SEAT BELT RETRACTOR : Exploded View"](#).
3. Remove luggage side upper finisher clips and metal clips with remover tool.

- : Clip  
□ : Metal clip

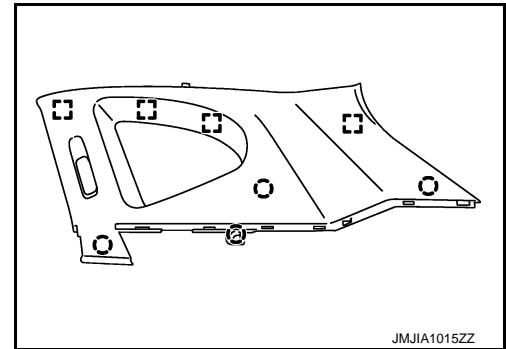

4. Remove luggage side upper finisher.

### INSTALLATION

Install in the reverse order of removal.

#### **CAUTION:**

**Check that clips, pawls, metal clips are securely fitted in panel holes on body when installing, and then press them in.**

# BACK DOOR TRIM

< REMOVAL AND INSTALLATION >



## BACK DOOR TRIM

Exploded View

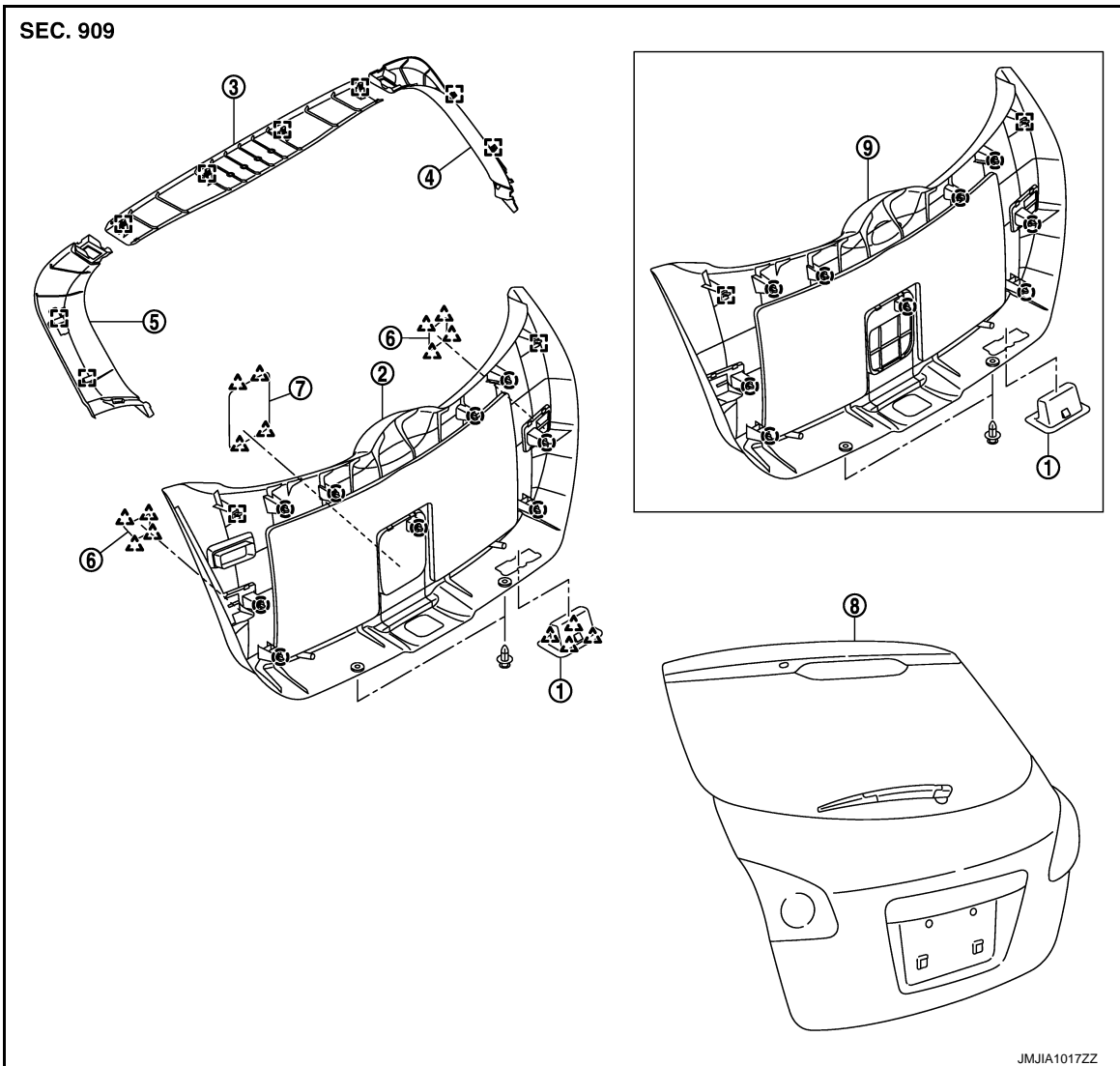
INFOID:000000006201304



- |                                     |  |   |
|-------------------------------------|--|---|
| 1. Pull handle                      | 2. Back door lower finisher inner (for SL) | 3. Back door upper finisher inner         |
| 4. Back door side finisher inner RH | 5. Back door side finisher inner LH        | 6. Lid                                    |
| 7. Emergency lid                    | 8. Back door assembly                      | 9. Back door lower finisher inner (for S) |

-  : Clip
-  : Pawl
-  : Metal clip

## Removal and Installation

INFOID:000000006201305

### REMOVAL

#### BACK DOOR LOWER FINISHER INNER

1. Fully open back door.

A  
B  
C  
D  
E  
F  
G  
H  
I  
INT  
K  
L  
M  
N  
O  
P

# BACK DOOR TRIM

## < REMOVAL AND INSTALLATION >

2. Disengage pull handle (1) fixing pawls with remover tool (A).

 : Pawl

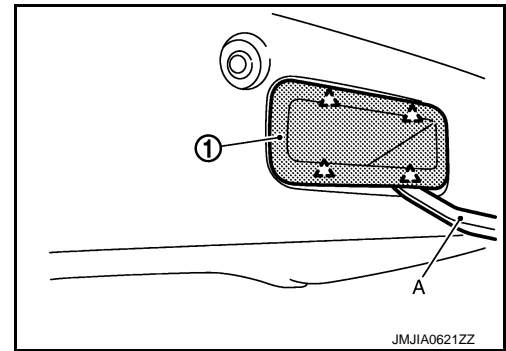

3. Push the clip center with a wrapped flat-blade screwdriver (B), the remove clip (A).

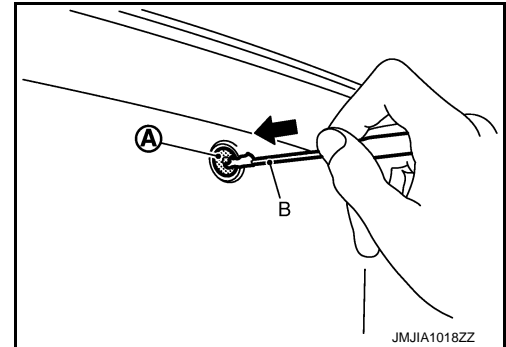

4. Insert remover tool (A) between back door lower finisher inner (1) and back door panel to disengage clips.

**NOTE:**

Starting from the lower downwards and works around the edges and up to the sides.

 : Clip

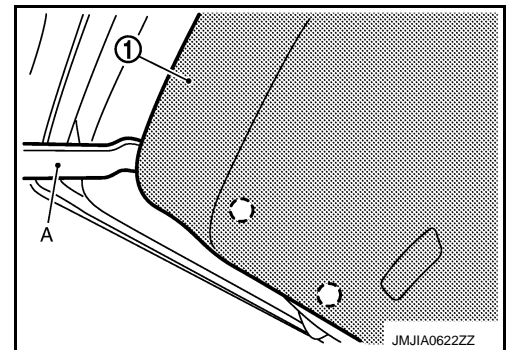

5. Pull out back door lower finisher inner.
6. Disconnect luggage room lamp connector (with luggage room lamp).
7. Remove back door lower finisher inner.
8. Remove the following parts after removing back door lower finisher inner.
  - Luggage room lamp assembly (with luggage room lamp). Refer to [INL-72, "Removal and Installation"](#).
  - Back door lids.

### BACK DOOR UPPER FINISHER INNER

1. Fully open back door.
2. Insert remover tool (A) between back door upper finisher inner (1) and back door panel to disengage clips.

 : Metal clip

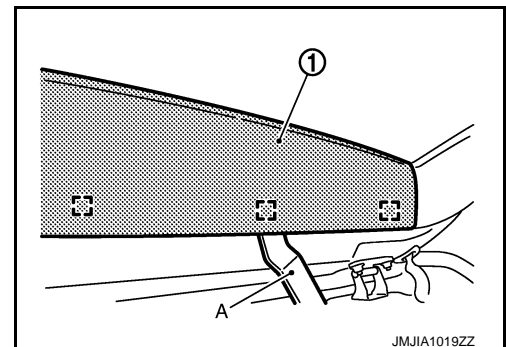

3. Remove back door upper finisher inner.

## BACK DOOR TRIM

### < REMOVAL AND INSTALLATION >

#### BACK DOOR SIDE FINISHER INNER

1. Fully open back door.
2. Remove back door lower finisher inner.
3. Remove back door upper finisher inner.
4. Insert remover tool (A) between back door side finisher inner (1) and back door panel to disengage metal clips.

 : Metal clip

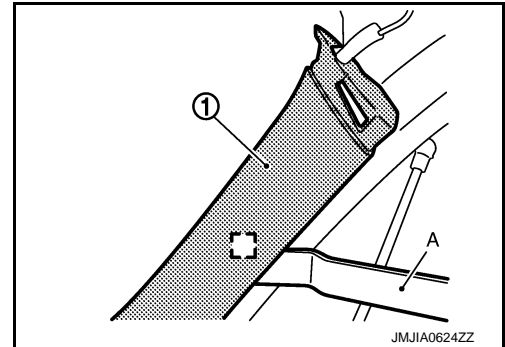

5. Remove back door side finisher inner.

#### INSTALLATION

Install in the reverse order of removal.

#### **CAUTION:**

**When installing back door trim, check that clips are securely fitted in panel holes on body, and then press them in.**

A  
B  
C  
D  
E  
F  
G  
H  
I  
INT  
K  
L  
M  
N  
O  
P