

A
B
C

SECTION **PB**

PARKING BRAKE SYSTEM

CONTENTS

<p>PREPARATION 2</p> <p>PREPARATION 2 Commercial Service Tool2</p> <p>PERIODIC MAINTENANCE 3</p> <p>PARKING BRAKE SYSTEM 3 Inspection and Adjustment3</p> <p>PARKING BRAKE SHOE 5 Inspection5</p> <p>REMOVAL AND INSTALLATION 6</p> <p>PARKING BRAKE CONTROL 6 Exploded View6</p>	<p>Removal and Installation 6 Adjustment 7</p> <p>PARKING BRAKE SHOE 8 Exploded View 8 Removal and Installation 8 Inspection and Adjustment 9</p> <p>SERVICE DATA AND SPECIFICATIONS (SDS)11</p> <p>SERVICE DATA AND SPECIFICATIONS (SDS)11 Parking Drum Brake11 Parking Brake Control11</p>	<p>PB</p> <p>G</p> <p>H</p> <p>I</p> <p>J</p> <p>K</p> <p>L</p> <p>M</p> <p>N</p> <p>O</p> <p>P</p>
--------------------------------------------------------------------------------------------------------------------------------------------------------------------------------------------------------------------------------------------------------------------------------------------------------------------------------------------------------------------------------------------------------------------------------------------------------------------------	-------------------------------------------------------------------------------------------------------------------------------------------------------------------------------------------------------------------------------------------------------------------------------------------------------------------------------------------------------------------------------------------------------------------------------------------------------------------------------------	------------------------------------------------------------------------------------------------------------

PREPARATION

< PREPARATION >

PREPARATION

PREPARATION

Commercial Service Tool

INFOID:000000007350190

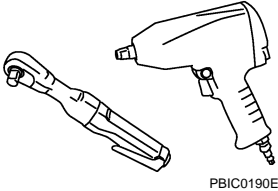
Tool name	Description
Power tool 	Loosening bolts and nuts

PARKING BRAKE SYSTEM

< PERIODIC MAINTENANCE >

PERIODIC MAINTENANCE

PARKING BRAKE SYSTEM

Inspection and Adjustment

INFOID:000000007350191

INSPECTION

Pedal Stroke

- Operate the parking brake pedal with a force of 196 N (20 kg, 44 lb). Check that the pedal stroke is within the specified number of notches. (Check it by listening to the clicks of the ratchet.)

Standard

Number of notches : Refer to [PB-11, "Parking Brake Control"](#).

- When brake warning lamp turns ON, check that the pedal stroke is within the specified number of notches. (Check it by listening to the clicks of the ratchet.)

Standard

Number of notches : Refer to [PB-11, "Parking Brake Control"](#).

Inspect Components

- Check each component for installation condition such as looseness.
- Check the parking brake pedal assembly for bend, damage and cracks. Replace if necessary.
- Check the cables for wear, damage and cracks. Replace if necessary.
- Check the parking brake switch, and replace it if necessary. Refer to [BRC-50, "Component Inspection"](#) (with-out VDC), [BRC-151, "Component Inspection"](#) (with VDC).

ADJUSTMENT

- To perform adjustment operations, remove rear tires with power tool.

1. Fix the disc rotor using wheel nuts.
2. Release the parking brake pedal (1) by turning the adjusting nut (2) with a deep socket wrench and loosening the cable.

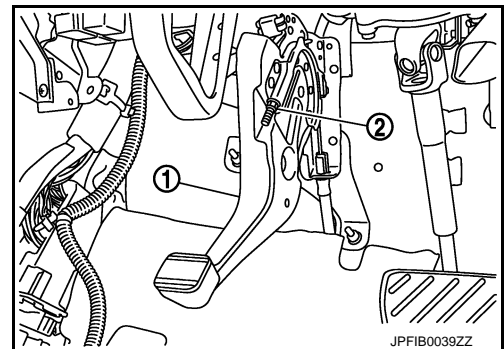

3. Remove the adjusting hole plug from the disc rotor. Turn the adjuster (1) in the direction (A) as shown in the figure using a suitable tool until the disc rotor is locked.
4. Turn back the adjuster 7 notches from the locked position.
5. Rotate the disc rotor to check that there is no drag. Install the adjusting hole plug.
6. Adjust the cable with the following procedure.
 - a. Operate the parking brake pedal with a force of 490 N (50 kg, 110 lb) for 10 strokes or more.
 - b. Adjust the parking brake pedal stroke by turning the adjusting nut with a deep socket wrench.

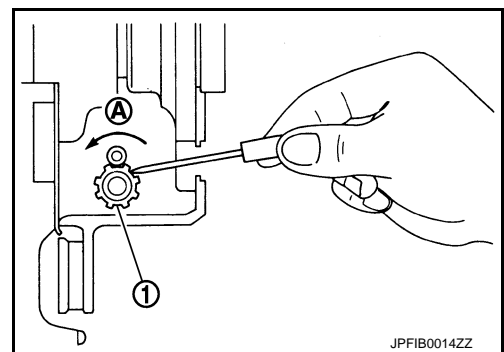

CAUTION:

Never reuse the adjusting nut if the nut is removed.

- c. Operate the parking brake pedal with a force of 196 N (20 kg, 44 lb). Check that the pedal stroke is within the specified number of notches. (Check it by listening to the clicks of the ratchet.)

PARKING BRAKE SYSTEM

< PERIODIC MAINTENANCE >

Standard

Number of notches : Refer to [PB-11, "Parking Brake Control"](#).

- d. Rotate the disc rotor with the parking brake pedal released and check that there is no drag.

PARKING BRAKE SHOE

< PERIODIC MAINTENANCE >

PARKING BRAKE SHOE

Inspection

INFOID:000000007350192

Rotate the disc rotor and check for any drag.

A

B

C

D

E

PB

G

H

I

J

K

L

M

N

O

P

PARKING BRAKE CONTROL

< REMOVAL AND INSTALLATION >

REMOVAL AND INSTALLATION

PARKING BRAKE CONTROL

Exploded View

INFOID:000000007350193

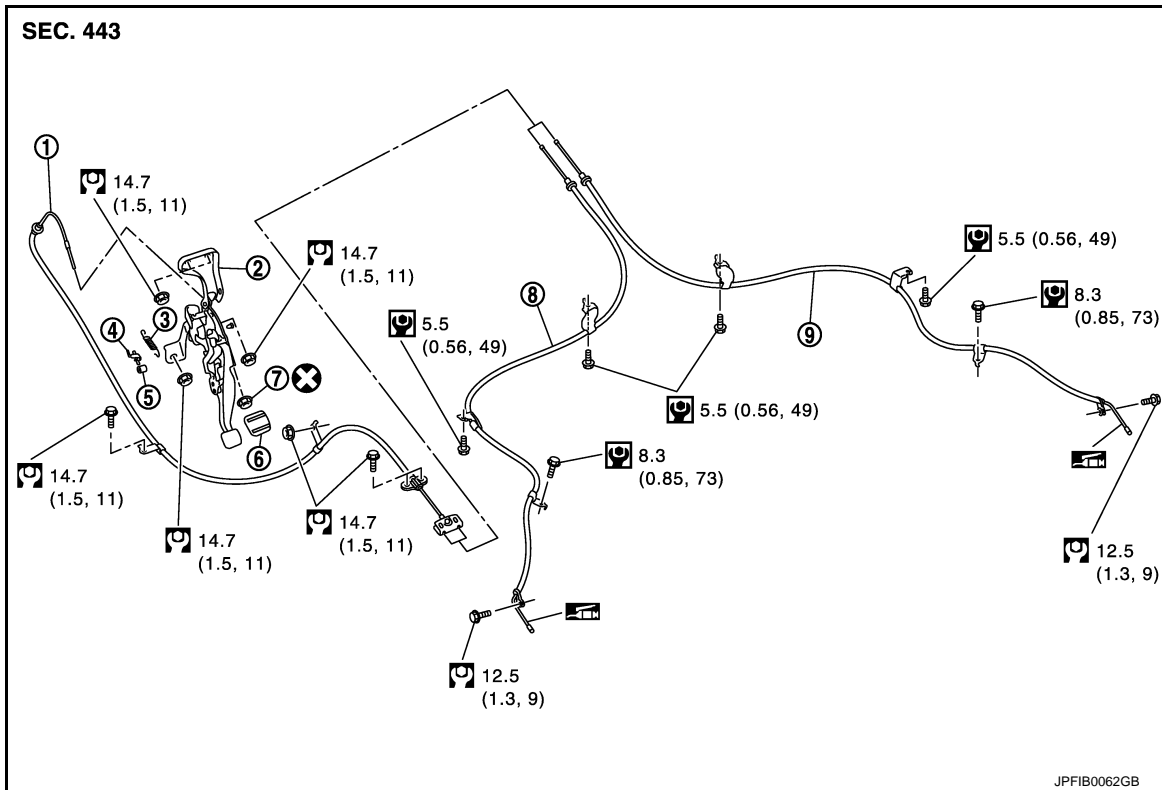

- | | | |
|-------------------------|---------------------------------|--------------------|
| 1. Front cable | 2. Parking brake pedal assembly | 3. Return spring |
| 4. Parking brake switch | 5. Stopper rubber | 6. Pedal pad |
| 7. Adjusting nut | 8. Rear cable (LH) | 9. Rear cable (RH) |

 Apply multi-purpose grease.

Refer to [GI-4, "Components"](#) for symbols not described on the above.

Removal and Installation

INFOID:000000007350194

REMOVAL

1. Remove rear tires with power tool.
2. Remove instrument driver lower cover. Refer to [IP-13, "Exploded View"](#).
3. Disconnect parking brake switch harness connector.
4. Remove adjusting nut and loosen front cable.
5. Remove parking brake pedal assembly.
6. Remove center console. Refer to [IP-22, "Exploded View"](#).
7. Remove the exhaust center tube and muffler assembly. Refer to [EX-4, "Exploded View"](#).
8. Separate front cable from rear cable, and remove front cable.
9. Remove parking brake shoe, and remove rear cable from toggle lever. Refer to [PB-8, "Exploded View"](#).
10. Remove rear cable mounting bolts pull out rear cable from vehicle.

INSTALLATION

Installation is the reverse order of the removal.

PARKING BRAKE CONTROL

< REMOVAL AND INSTALLATION >

Adjustment

INFOID:000000007350195

ADJUSTMENT AFTER INSTALLATION

Adjust the parking brake lever stroke. Refer to [PB-3. "Inspection and Adjustment"](#).

- A
- B
- C
- D
- E
- PB**
- G
- H
- I
- J
- K
- L
- M
- N
- O
- P

PARKING BRAKE SHOE

< REMOVAL AND INSTALLATION >

PARKING BRAKE SHOE

Exploded View

INFOID:000000007350196

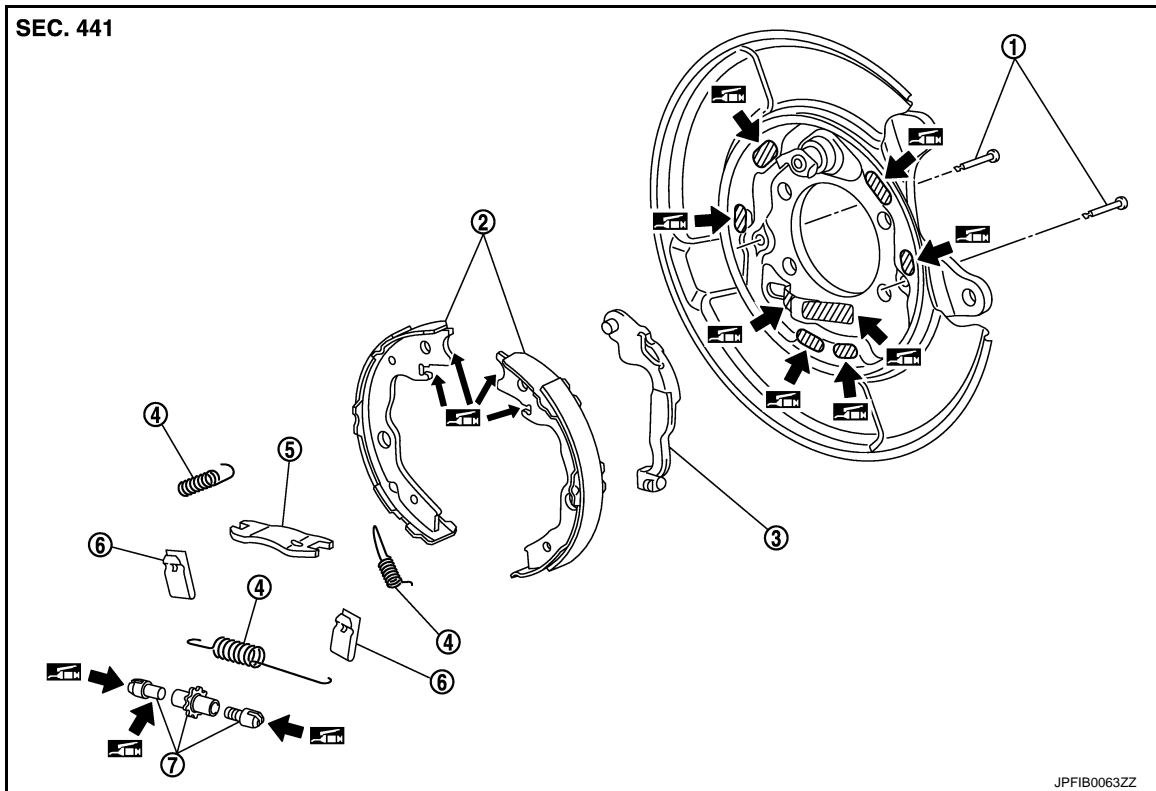

- | | | |
|--------------------|-----------------------|-----------------|
| 1. Anti-rattle pin | 2. Parking brake shoe | 3. Toggle lever |
| 4. Return spring | 5. Brake strut | 6. Spring |
| 7. Adjuster | | |

 Apply PBC (Poly Butyl Cuprysil) grease or silicone-based grease.

Removal and Installation

INFOID:000000007350197

REMOVAL

WARNING:

Since dust covering the parking brake has an affect on human body, the dust must be removed with a dust collector. Never splatter the dust with an air blow gun.

1. Remove rear tires with power tool.
2. Remove disc rotor with parking brake completely in the released position. Refer to [BR-43, "BRAKE CALI-PER ASSEMBLY : Removal and Installation"](#).

CAUTION:

- Put matching marks on the disc rotor and the wheel hub and bearing assembly when reusing the disc rotor.
 - Never drop disc rotor.
3. If disc rotor cannot be removed, remove as follows:
 - a. Fix the disc rotor with wheel nuts and remove the adjusting hole plug.

PARKING BRAKE SHOE

< REMOVAL AND INSTALLATION >

- b. Using suitable tool, rotate adjuster (1) in direction (B) to retract and loosen parking brake shoe.
4. Remove anti-rattle pins, springs, and return springs.

CAUTION:

Never drop the removed parts.

5. Remove brake strut, adjuster, parking brake shoes and toggle lever.

CAUTION:

- The parking brake shoes for the front side are made of different materials from those for the rear side. Never misidentify them when removing.
- Never drop the removed parts.

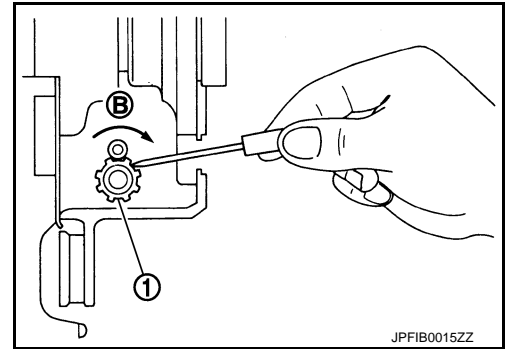

6. For the removal of back plate, refer to [RAX-5, "Exploded View"](#) (2WD), [RAX-13, "Exploded View"](#) (AWD).

INSTALLATION

Note the following, and install in the reverse order of removal.

- Apply PBC (Poly Butyl Cuprysil) grease or silicone-based grease to the back plate and brake shoe.

CAUTION:

The parking brake shoes for the front side are made of different materials from those for the rear side. Never misidentify them when removing and replacing.

- Assemble adjusters so that threaded part is expanded when rotating it in the direction shown by arrow.

A: For RH brake

B: For LH brake

↔: Vehicle front

←: Adjuster expands

- Shorten adjuster by rotating it.
- When disassembling, apply PBC (Poly Butyl Cuprysil) grease or silicone-based grease to threads.
- Check parking brake shoe sliding surface and drum inner surface for grease. Wipe it off if it adhere on the surfaces.

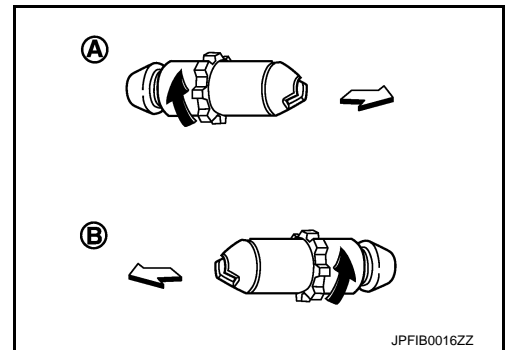

Inspection and Adjustment

INFOID:000000007350198

INSPECTION AFTER REMOVAL

Brake Lining Thickness Inspection

- Check thickness (A) of brake lining.

Standard thickness

: Refer to [PB-11, "Parking Drum Brake"](#).

Wear limit

: Refer to [PB-11, "Parking Drum Brake"](#).

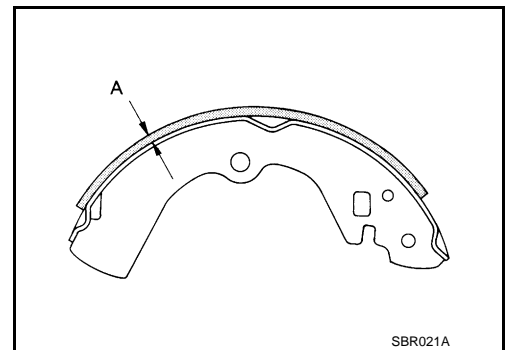

Drum Inner Diameter Inspection

PARKING BRAKE SHOE

< REMOVAL AND INSTALLATION >

- Check inner diameter (B) of drum.

Standard inner diameter : Refer to [PB-11, "Parking Drum Brake"](#).

Wear limit of inner diameter : Refer to [PB-11, "Parking Drum Brake"](#).

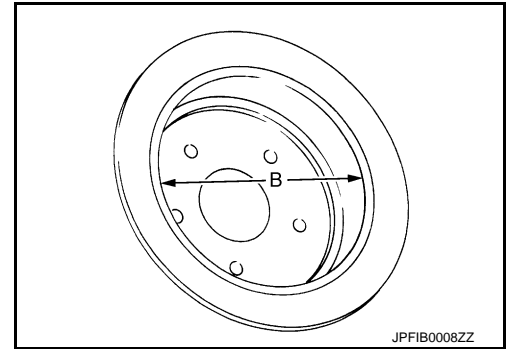

Other Inspections

- Check brake lining for excessive wear, damage, and peeling. Replace if necessary.
- Check parking brake shoe sliding surface for excessive wear and damage. Replace if necessary.
- Check anti-rattle pin for excessive wear, damage and rust. Replace if necessary.
- Check spring and return springs for settling, excessive wear, damage, and rust. Replace if necessary.
- Check brake strut for excessive wear, damage and rust. Replace if necessary.
- Check adjuster for smoothness. Replace if necessary.
- Check toggle lever for excessive wear, damage and rust. Replace if necessary.
- Visually check inside of the drum for excessive wear, cracks, and damage with a pair of vernier calipers. Replace if necessary.

ADJUSTMENT AFTER INSTALLATION

- Adjust the parking brake pedal stroke. Refer to [PB-3, "Inspection and Adjustment"](#).
- Perform break-in operation as follows after replacing parking brake shoe and/or disc rotor, or if brakes do not function well.

1. Adjust parking pedal stroke to the specified amount. Refer to [PB-3, "Inspection and Adjustment"](#).
2. Perform parking brake break-in (drag on) operation by driving vehicle under the following conditions:

Drive forward

- Vehicle speed : Approx. 40 km/h (25 MPH) set (constant and forward)
- Parking brake operating force : Approx. 130 N (13.3 kg, 29 lb) set constant
- Time : Approx. 10 sec.

CAUTION:

To prevent lining from getting too hot, allow a cool off period of approximately 5 minutes after every break-in operation.

3. After the break-in procedure, check parking pedal stroke of parking brake. If it is out of the specification, adjust again. Refer to [PB-3, "Inspection and Adjustment"](#).

SERVICE DATA AND SPECIFICATIONS (SDS)

< SERVICE DATA AND SPECIFICATIONS (SDS)

SERVICE DATA AND SPECIFICATIONS (SDS)

SERVICE DATA AND SPECIFICATIONS (SDS)

Parking Drum Brake

INFOID:000000007350199

Unit: mm (in)

Item		Limit
Brake lining	Wear limit	1.5 (0.059)
Drum (disc)	Wear limit of inner diameter	173 (6.81)

Parking Brake Control

INFOID:000000007350200

Item		Standard
Number of notches [under force of 196 N (20 kg, 44 lb)]		6 – 7 notches
Number of notches when brake warning lamp turns ON		1 notch

A
B
C
D
E
PB
G
H
I
J
K
L
M
N
O
P