

SECTION PCS

POWER CONTROL SYSTEM

A
B
C
D
E
F
G
H
I
J
K
L
N
O
P

CONTENTS

<p>IPDM E/R</p> <p>SYSTEM DESCRIPTION 2</p> <p>RELAY CONTROL SYSTEM 2</p> <p> System Diagram 2</p> <p> System Description 2</p> <p> Component Parts Location 4</p> <p>SIGNAL BUFFER SYSTEM 5</p> <p> System Diagram 5</p> <p> System Description 5</p> <p> Component Parts Location 5</p> <p>POWER CONSUMPTION CONTROL SYSTEM 6</p> <p> System Diagram 6</p> <p> System Description 6</p> <p> Component Parts Location 7</p> <p>DIAGNOSIS SYSTEM (IPDM E/R) 8</p> <p> Diagnosis Description 8</p> <p> CONSULT Function (IPDM E/R) 10</p> <p>DTC/CIRCUIT DIAGNOSIS 13</p> <p>U1000 CAN COMM CIRCUIT 13</p> <p> Description 13</p> <p> DTC Logic 13</p> <p> Diagnosis Procedure 13</p> <p>B2099 IGNITION RELAY OFF STUCK 14</p> <p> Description 14</p> <p> DTC Logic 14</p>	<p> Diagnosis Procedure 14</p> <p>POWER SUPPLY AND GROUND CIRCUIT 15</p> <p> Diagnosis Procedure 15</p> <p>ECU DIAGNOSIS INFORMATION 16</p> <p>IPDM E/R (INTELLIGENT POWER DISTRIBUTION MODULE ENGINE ROOM) 16</p> <p> Reference Value 16</p> <p> Wiring Diagram - IPDM E/R - 21</p> <p> Fail-safe 23</p> <p> DTC Index 25</p> <p>PRECAUTION 26</p> <p>PRECAUTIONS 26</p> <p>FOR USA AND CANADA 26</p> <p> FOR USA AND CANADA : Precaution for Supplemental Restraint System (SRS) "AIR BAG" and "SEAT BELT PRE-TENSIONER" 26</p> <p>FOR MEXICO 26</p> <p> FOR MEXICO : Precaution for Supplemental Restraint System (SRS) "AIR BAG" and "SEAT BELT PRE-TENSIONER" 26</p> <p>REMOVAL AND INSTALLATION 28</p> <p>IPDM E/R (INTELLIGENT POWER DISTRIBUTION MODULE ENGINE ROOM) 28</p> <p> Exploded View 28</p> <p> Removal and Installation 28</p>
--	--

PCS

RELAY CONTROL SYSTEM

< SYSTEM DESCRIPTION >

[IPDM E/R]

SYSTEM DESCRIPTION

RELAY CONTROL SYSTEM

System Diagram

INFOID:000000007353656

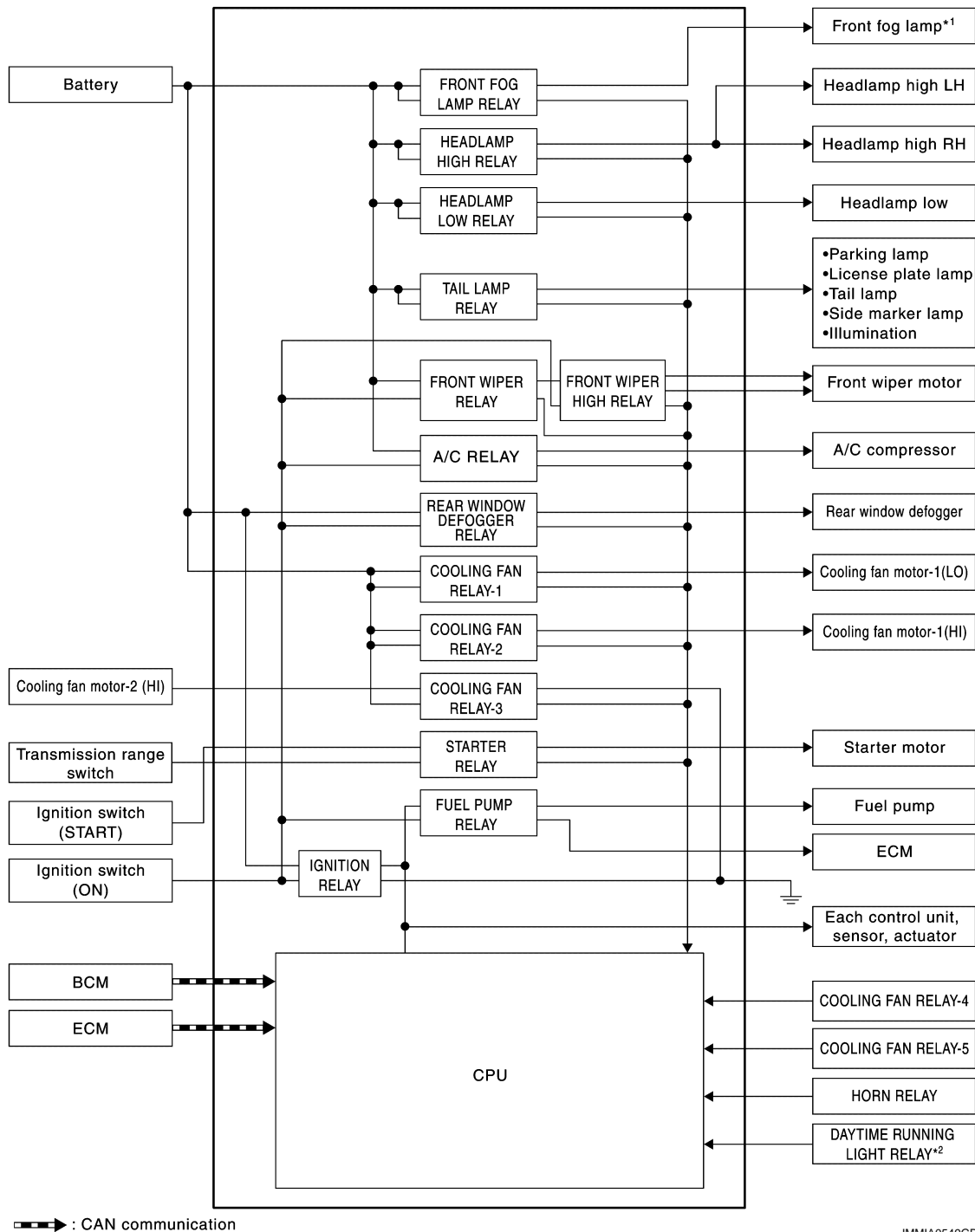

JMMIA0549GB

NOTE:

- *1: With front fog lamp system
- *2: With daytime running light system

System Description

INFOID:000000007353657

IPDM E/R activates the internal control circuit to perform the relay ON-OFF control according to the input signals from various sensors and the request signals received from control units via CAN communication.

CAUTION:

RELAY CONTROL SYSTEM

< SYSTEM DESCRIPTION >

[IPDM E/R]

IPDM E/R integrated relays cannot be removed.

Control relay	Input/output	Transmit unit	Control part	Reference page
Headlamp low relay	Low beam request signal	BCM (CAN)	<ul style="list-style-type: none"> Headlamp low Aiming motor (With xenon headlamp) 	<ul style="list-style-type: none"> EXL-9 (Xenon headlamp) EXL-125 (Halogen headlamp)
Headlamp high relay	High beam request signal		Headlamp high	
Front fog lamp relay	Front fog light request signal	BCM (CAN)	Front fog lamp NOTE: With front fog lamp system	EXL-13
Tail lamp relay	Position light request signal	BCM (CAN)	<ul style="list-style-type: none"> Parking lamp License plate lamp Tail lamp Side marker lamp 	<ul style="list-style-type: none"> EXL-17 (Xenon headlamp) EXL-136 "System Diagram" (Halogen headlamp)
			Illuminations	INL-13
<ul style="list-style-type: none"> Front wiper relay Front wiper high relay 	Front wiper request signal	BCM (CAN)	Front wiper	WWV-6
	Front wiper stop position signal	Front wiper motor		
Rear window defogger relay	Rear window defogger switch signal	BCM (CAN)	Rear window defogger	DEF-4
Starter relay	<ul style="list-style-type: none"> Ignition switch START signal Transmission range switch signal 	<ul style="list-style-type: none"> Ignition switch Transmission range switch 	Starter motor	<ul style="list-style-type: none"> SEC-10 (With Intelligent Key) SEC-130 (Without Intelligent Key)
<ul style="list-style-type: none"> Cooling fan relay-1 Cooling fan relay-2 Cooling fan relay-3 Cooling fan relay-4 Cooling fan relay-5 	Cooling fan speed request signal	ECM (CAN)	Cooling fan	<ul style="list-style-type: none"> EC-73 (Except for Mexico) EC-514 (For Mexico)
A/C relay	A/C compressor request signal	ECM (CAN)	A/C compressor (Magnet clutch)	HAC-118
Ignition relay	Ignition switch ON signal	Ignition switch	Each control unit, sensor, actuator and relay (Ignition power supply)	PCS-14
Horn relay	Horn request signal	BCM (CAN)	Horn	<ul style="list-style-type: none"> Vehicle security system <ul style="list-style-type: none"> - SEC-20 (With Intelligent Key) - SEC-134 (Without Intelligent Key) Panic alarm <ul style="list-style-type: none"> - DLK-20 (With Intelligent Key) - DLK-260 (Without Intelligent Key) Horn reminder <ul style="list-style-type: none"> - DLK-20 (With Intelligent Key) - DLK-260 (Without Intelligent Key)
Daytime running light relay NOTE: With daytime running light system	Daytime running light request signal	BCM (CAN)	Headlamp HI (Daytime running light operation)	EXL-129 , "System Diagram"

A
B
C
D
E
F
G
H
I
J
K
L
PCS
N
O
P

PCS

RELAY CONTROL SYSTEM

[IPDM E/R]

< SYSTEM DESCRIPTION >

Component Parts Location

INFOID:000000007353658

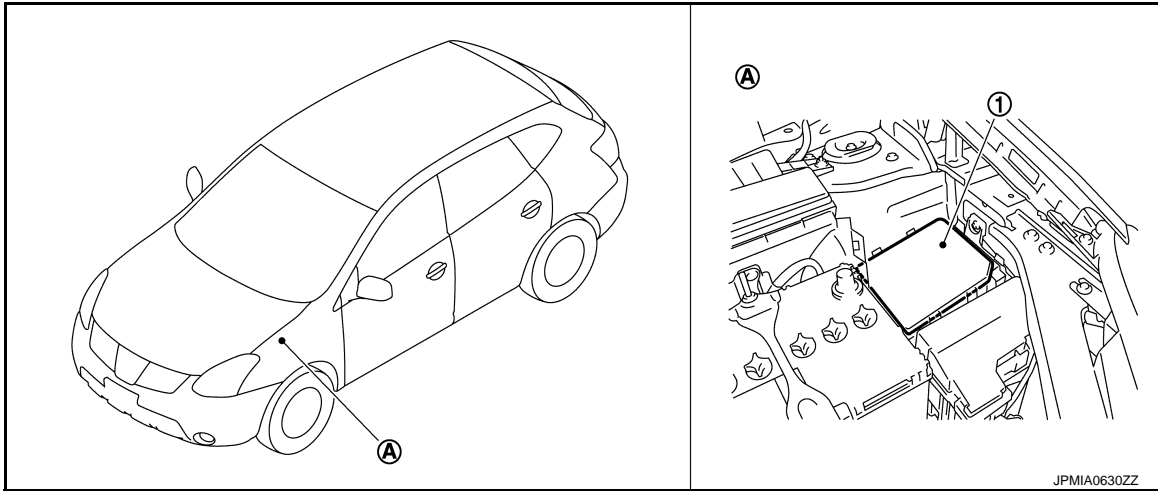

- 1. IPDM E/R
- A. Engine room (LH)

SIGNAL BUFFER SYSTEM

< SYSTEM DESCRIPTION >

[IPDM E/R]

SIGNAL BUFFER SYSTEM

System Diagram

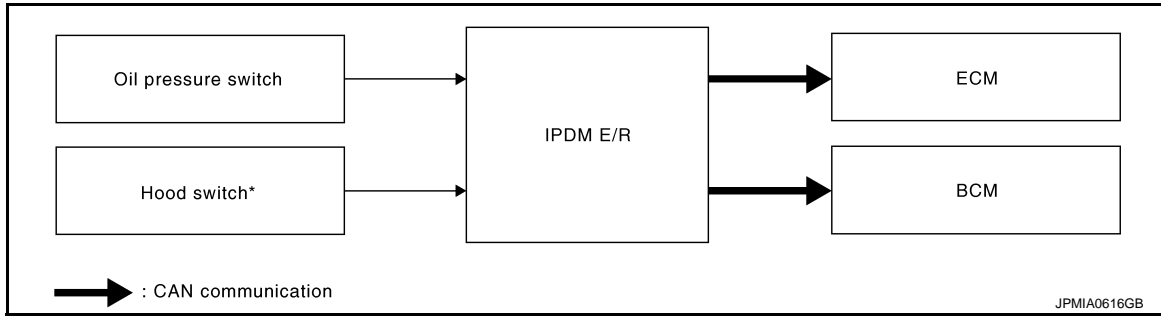

NOTE:

*: For Mexico

System Description

INFOID:000000007353660

- IPDM E/R reads the status of the oil pressure switch and transmits the oil pressure switch signal to BCM and ECM via CAN communication. Refer to [MWI-13. "OIL PRESSURE WARNING LAMP : System Diagram"](#).
- IPDM E/R reads the status of the hood switch and transmits the hood switch signal to BCM via CAN communication. Refer to [SEC-20. "System Diagram"](#) (With Intelligent Key) or [SEC-134. "System Diagram"](#) (Without Intelligent Key).

Component Parts Location

INFOID:000000007563083

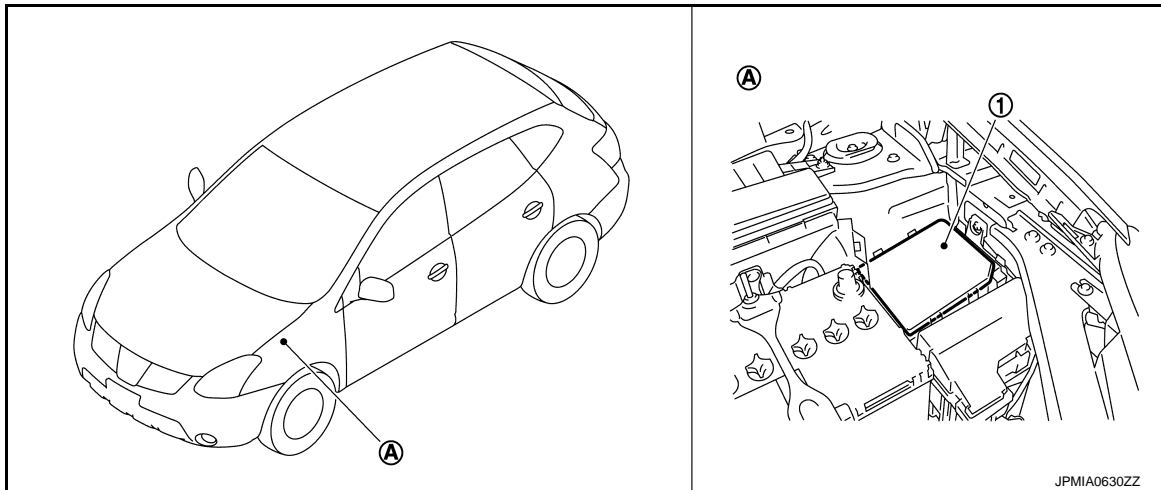

1. IPDM E/R
- A. Engine room (LH)

PCS

POWER CONSUMPTION CONTROL SYSTEM

System Diagram

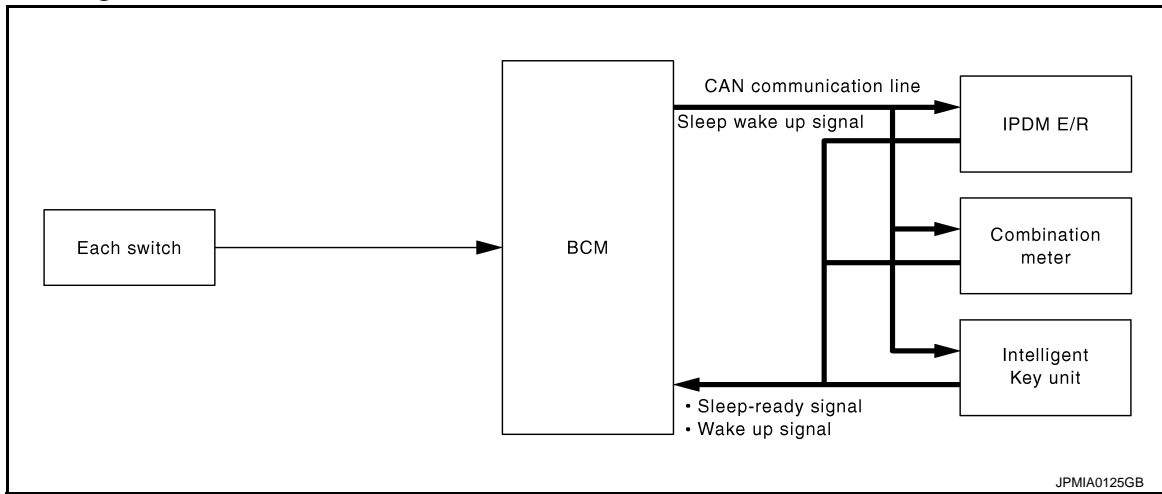

System Description

INFOID:000000007353663

OUTLINE

- IPDM E/R incorporates a power consumption control function that reduces the power consumption according to the vehicle status.
- IPDM E/R changes its status (control mode) with the sleep wake up signal received from BCM via CAN communication.

Normal mode (wake-up)

- CAN communication is normally performed with other control units.
- Individual unit control by IPDM E/R is normally performed.

Low power consumption mode (sleep)

- Low power consumption control is active.
- CAN transmission is stopped.

Sleep mode activation

- IPDM E/R judges that the sleep-ready conditions are fulfilled when the ignition switch is OFF and none of the conditions below are present. Then it transmits a sleep-ready signal (ready) to BCM via CAN communication.
 - Front wiper fail-safe operation
 - Ignition relay ON or OFF stuck detection
 - Outputting signals to actuators
 - Switches or relays operating
 - Auto active test is starting
 - Communicating with CONSULT
 - Hood switch status is changed (For Mexico)
 - Output requests are being received from control units via CAN communication.
- IPDM E/R stops CAN communication and enters the low power consumption mode when it receives a sleep wake up signal (sleep) from BCM and the sleep-ready conditions are fulfilled.

Wake-up operation

- IPDM E/R changes from the low power consumption mode to the normal mode when it receives a sleep wake-up signal (wake up) from BCM or any of the following conditions is fulfilled. In addition, it transmits a sleep-ready signal (not-ready) to BCM via CAN communication to report the CAN communication start.
 - Ignition switch ON
 - The hood switch status changes. (For Mexico)
 - An output request is received from a control unit via CAN communication.

POWER CONSUMPTION CONTROL SYSTEM

< SYSTEM DESCRIPTION >

[IPDM E/R]

Component Parts Location

INFOID:000000007353664

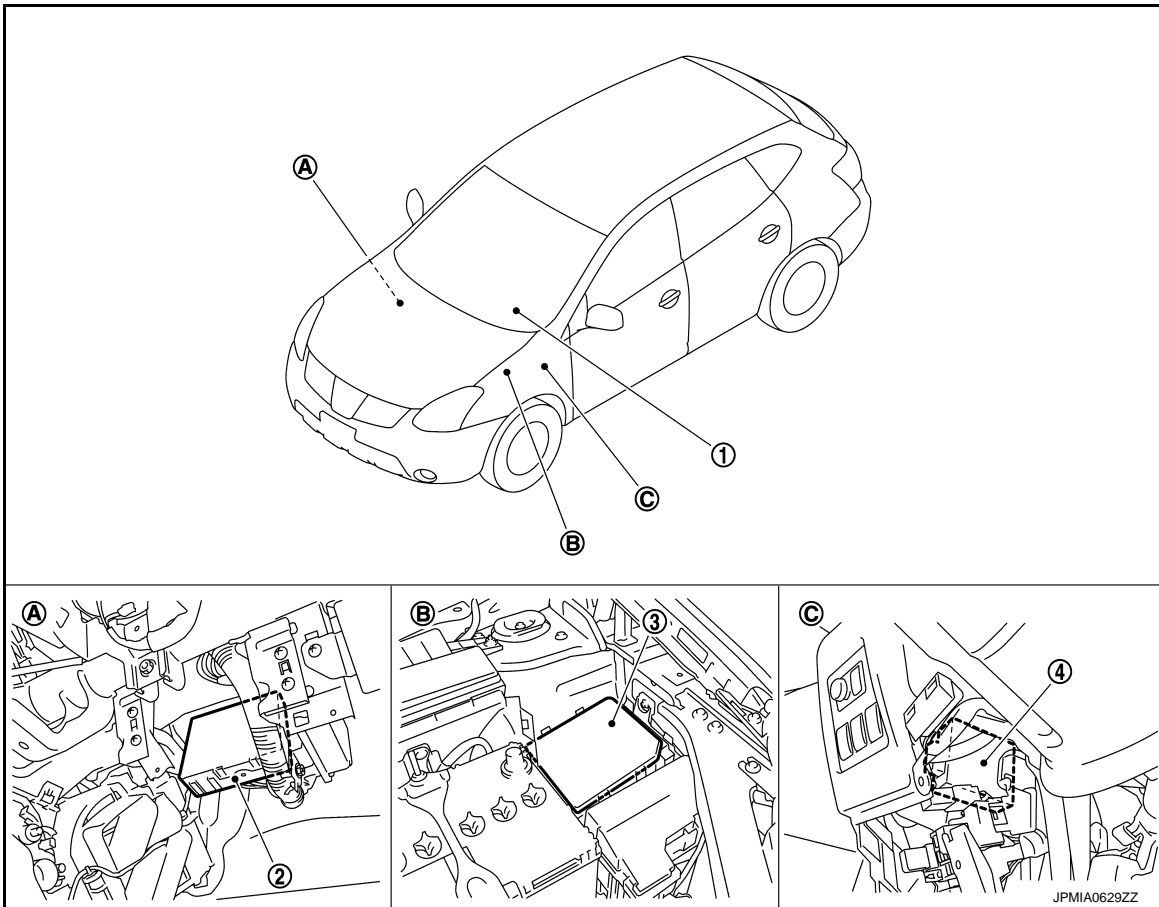

- 1. Combination meter
- 4. Intelligent Key unit
- A. Over the glove box

- 2. BCM
- B. Engine room (LH)

- 3. IPDM E/R
- C. Over the instrument lower panel (driver side)

A
B
C
D
E
F
G
H
I
J
K
L

PCS

N
O
P

DIAGNOSIS SYSTEM (IPDM E/R)

Diagnosis Description

INFOID:000000007353665

Auto active test

Description

In auto active test mode, the IPDM E/R sends a drive signal to the following systems to check their operation.

- Oil pressure warning lamp
- Rear window defogger
- Front wiper (LO, HI)
- Parking lamp
- License plate lamp
- Tail lamp
- Side marker lamp
- Front fog lamp
- Headlamp (LO, HI)
- A/C compressor (magnet clutch)
- Cooling fan (LO, MID, HI)

Operation procedure

1. Close the hood and lift the wiper arms from the windshield. (Prevent windshield damage due to wiper operation)

NOTE:

When auto active test is performed with hood opened, sprinkle water on windshield beforehand.

2. Turn the ignition switch OFF.
3. Turn the ignition switch ON, and within 20 seconds, press the driver door switch 10 times. Then turn the ignition switch OFF.

CAUTION:

Close passenger door.

4. Turn the ignition switch ON within 10 seconds. Then the horn sounds once and the auto active test starts.

NOTE:

Only a vehicle with the vehicle security system, the horn sounds.

5. The oil pressure warning lamp starts blinking when the auto active test starts.
6. After a series of the following operations is repeated 3 times, auto active test is completed.

NOTE:

When auto active test mode has to be cancelled halfway through test, turn the ignition switch OFF.

CAUTION:

- **If auto active test mode cannot be actuated, check door switch system.**
- **Never start the engine.**

Inspection in auto active test mode

When auto active test mode is actuated, the following 6 steps are repeated 3 times.

Operation sequence	Inspection location	Operation
A	Oil pressure warning lamp	Blinks continuously during operation of auto active test.
1	Rear window defogger	10 seconds
2	Front wiper motor	LO for 5 seconds → HI for 5 seconds
3	<ul style="list-style-type: none"> • Parking lamp • License plate lamp • Tail lamp • Side marker lamp • Front fog lamp • Headlamps HI (daytime running light operation)* 	10 seconds
4	Headlamp	LO 10 seconds → ↔ OFF 5 times
5	A/C compressor (magnet clutch)	ON ↔ OFF 5 times
6	Cooling fan	LO for 5 seconds → MID for 3 seconds → HI for 2 seconds

DIAGNOSIS SYSTEM (IPDM E/R)

[IPDM E/R]

< SYSTEM DESCRIPTION >

NOTE:

*: With daytime running light system

Concept of auto active test

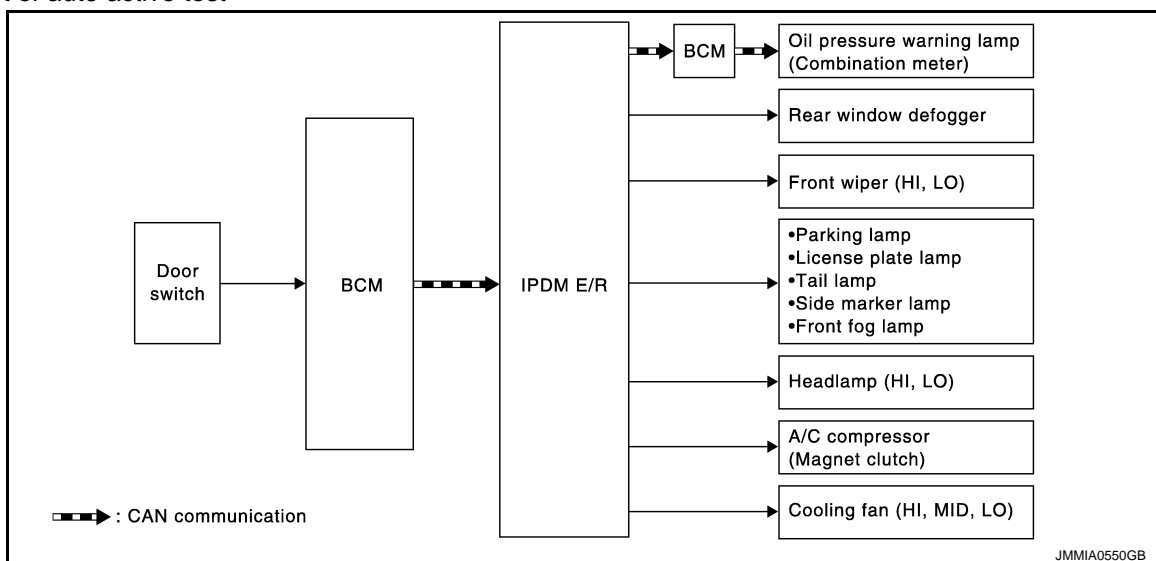

- IPDM E/R starts the auto active test with the door switch signals transmitted by BCM via CAN communication. Therefore, the CAN communication line between IPDM E/R and BCM is considered normal if the auto active test starts successfully.
- The auto active test facilitates troubleshooting if any systems controlled by IPDM E/R cannot be operated.

Diagnosis chart in auto active test mode

Symptom	Inspection contents	Possible cause
Rear window defogger does not operate	Perform auto active test. Does the rear window defogger operate?	YES BCM signal input circuit
		NO <ul style="list-style-type: none"> • Rear window defogger • Rear window defogger ground circuit • Harness or connector between IPDM E/R and rear window defogger • IPDM E/R
Any of the following components do not operate • Parking lamp • License plate lamp • Tail lamp • Side marker lamp • Front fog lamp • Headlamp (HI, LO) • Front wiper motor (HI, LO)	Perform auto active test. Does the applicable system operate?	YES BCM signal input circuit
		NO <ul style="list-style-type: none"> • Lamp or motor • Lamp or motor ground circuit • Harness or connector between IPDM E/R and applicable system • IPDM E/R
Headlamps HI (daytime running light operation) do not operate	Perform auto active test. Do headlamps HI (daytime running light operation) operate?	YES <ul style="list-style-type: none"> • CAN communication signal between ECM and BCM • CAN communication signal between combination meter and BCM • BCM signal input circuit
		NO <ul style="list-style-type: none"> • Daytime running light relay power supply circuit • Harness or connector between IPDM E/R and daytime running light relay • Daytime running light relay

DIAGNOSIS SYSTEM (IPDM E/R)

< SYSTEM DESCRIPTION >

[IPDM E/R]

Symptom	Inspection contents	Possible cause
A/C compressor does not operate	Perform auto active test. Does the magnet clutch operate?	YES <ul style="list-style-type: none"> • BCM signal input circuit • CAN communication signal between BCM and ECM • CAN communication signal between ECM and IPDM E/R
		NO <ul style="list-style-type: none"> • Magnet clutch • Harness or connector between IPDM E/R and magnet clutch • IPDM E/R
Oil pressure warning lamp does not operate	Perform auto active test. Does the oil pressure warning lamp blink?	YES <ul style="list-style-type: none"> • Harness or connector between IPDM E/R and oil pressure switch • Oil pressure switch • IPDM E/R
		NO <ul style="list-style-type: none"> • CAN communication signal between IPDM E/R and BCM • CAN communication signal between BCM and combination meter • Combination meter
Cooling fan does not operate	Perform auto active test. Does the cooling fan operate?	YES <ul style="list-style-type: none"> • ECM signal input circuit • CAN communication signal between ECM and IPDM E/R
		NO <ul style="list-style-type: none"> • Cooling fan motor-2 power supply circuit • Cooling fan motor-1 ground circuit • Cooling fan relay-4 or cooling fan relay-5 power supply circuit • Cooling fan relay-5 ground circuit • Harness or connector between IPDM E/R and cooling fan motor • Harness or connector between IPDM E/R, and cooling fan relay-4 or cooling fan relay-5 • Harness or connector between cooling fan motor-2, and cooling fan relay-4 or cooling fan relay-5 • Cooling fan relay-4 or cooling fan relay-5 • Cooling fan motor • IPDM E/R

CONSULT Function (IPDM E/R)

INFOID:000000007353666

APPLICATION ITEM

CONSULT performs the following functions via CAN communication with IPDM E/R.

Diagnosis mode	Description
Self Diagnostic Result	Displays the diagnosis results judged by IPDM E/R.
Data Monitor	Displays the real-time input/output data from IPDM E/R input/output data.
Active Test	IPDM E/R can provide a drive signal to electronic components to check their operations.
CAN Diag Support Monitor	The results of transmit/receive diagnosis of CAN communication can be read.

SELF DIAGNOSTIC

Refer to [PCS-25. "DTC Index"](#).

DATA MONITOR

Monitor item

DIAGNOSIS SYSTEM (IPDM E/R)

< SYSTEM DESCRIPTION >

[IPDM E/R]

Monitor Item [Unit]	MAIN SIGNALS	Description	
MOTOR FAN REQ [1 - 4]	×	Displays the value of the cooling fan speed signal received from ECM via CAN communication.	A
AC COMP REQ [Off/On]	×	Displays the status of the A/C compressor request signal received from ECM via CAN communication.	B
TAIL&CLR REQ [Off/On]	×	Displays the status of the position light request signal received from BCM via CAN communication.	C
HL LO REQ [Off/On]	×	Displays the status of the low beam request signal received from BCM via CAN communication.	D
HL HI REQ [Off/On]	×	Displays the status of the high beam request signal received from BCM via CAN communication.	E
FR FOG REQ [Off/On]	×	Displays the status of the front fog light request signal received from BCM via CAN communication. NOTE: This item is monitored only the vehicle with front fog lamp system.	E
FR WIP REQ [Stop/1LOW/Low/Hi]	×	Displays the status of the front wiper request signal received from BCM via CAN communication.	F
WIP AUTO STOP [STOP P/ACT P]	×	Displays the status of the front wiper stop position signal judged by IPDM E/R.	G
WIP PROT [Off/BLOCK]	×	Displays the status of the front wiper fail-safe operation judged by IPDM E/R.	H
ST RLY REQ [Off/On]		Displays the status of the starter request signal.	H
IGN RLY [Off/On]	×	Displays the status of the ignition relay judged by IPDM E/R.	I
RR DEF REQ [Off/On]	×	Displays the status of the rear defogger request signal received from BCM via CAN communication.	I
OIL P SW [Open/Close]		Displays the status of the oil pressure switch judged by IPDM E/R.	J
DTRL REQ [Off/On]		Displays the status of the daytime running light request signal received from BCM via CAN communication. NOTE: This item is monitored only the vehicle with daytime running light system.	K
HOOD SW [Off/On]		Displays the status of the hood switch judged by IPDM E/R. NOTE: This item is monitored only the vehicle for Mexico.	L
THFT HRN REQ [Off/On]		Displays the status of the horn request signal by vehicle security system or panic alarm system received from BCM via CAN communication.	PCS
HORN CHIRP [Off/On]		Displays the status of the horn request signal by key fob LOCK operation received from BCM via CAN communication.	PCS

ACTIVE TEST

Test item

Test item	Operation	Description	
REAR DEFOGGER	Off	OFF	O
	On	Operates the rear window defogger relay.	P
FRONT WIPER	Off	OFF	
	Lo	Operates the front wiper relay.	
	Hi	Operates the front wiper relay and front wiper high relay.	

DIAGNOSIS SYSTEM (IPDM E/R)

< SYSTEM DESCRIPTION >

[IPDM E/R]

Test item	Operation	Description
MOTOR FAN	1	OFF
	2	Operates the cooling fan relay (LO operation).
	3	Operates the cooling fan relay (MID operation).
	4	Operates the cooling fan relay (HI operation).
EXTERNAL LAMPS	Off	OFF
	TAIL	Operates the tail lamp relay and the daytime running light relay. NOTE: Daytime running light relay is with daytime running light system only.
	Lo	Operates the headlamp low relay.
	Hi	Operates the headlamp low relay and ON/OFF the headlamp high relay at 4 seconds intervals.
	Fog	Operates the front fog lamp relay. NOTE: This item can test only the vehicle with front fog lamp system.
HORN	On	Operates horn relay for 20 ms.

DTC/CIRCUIT DIAGNOSIS

U1000 CAN COMM CIRCUIT

Description

INFOID:000000007353667

CAN (Controller Area Network) is a serial communication line for real time applications. It is an on-vehicle multiplex communication line with high data communication speed and excellent error detection ability. Modern vehicle is equipped with many electronic control unit, and each control unit shares information and links with other control units during operation (not independent). In CAN communication, control units are connected with 2 communication lines (CAN-H, CAN-L) allowing a high rate of information transmission with less wiring. Each control unit transmits/receives data but selectively reads required data only.

CAN Communication Signal Chart. Refer to [LAN-25, "CAN Communication Signal Chart"](#).

DTC Logic

INFOID:000000007353668

DTC DETECTION LOGIC

DTC	CONSULT display description	DTC Detection Condition	Possible cause
U1000	CAN COMM CIRCUIT	When IPDM E/R cannot communicate CAN communication signal continuously for 2 seconds or more.	CAN communication system

Diagnosis Procedure

INFOID:000000007353669

1. PERFORM SELF DIAGNOSTIC

1. Turn the ignition switch ON and wait for 2 seconds or more.
2. Check "Self Diagnostic Result".

Is DTC "U1000" displayed?

- YES >> Refer to [LAN-16, "Trouble Diagnosis Flow Chart"](#).
- NO >> Refer to [GI-45, "Intermittent Incident"](#).

PCS

B2099 IGNITION RELAY OFF STUCK

< DTC/CIRCUIT DIAGNOSIS >

[IPDM E/R]

B2099 IGNITION RELAY OFF STUCK

Description

INFOID:000000007353670

The ignition relay integrated in IPDM E/R is operated with ignition switch ON signal from the ignition switch.

DTC Logic

INFOID:000000007353671

DTC DETECTION LOGIC

DTC	CONSULT display description	DTC Detection Condition	Possible causes
B2099	IGN RELAY OFF	When CPU detects the ignition relay is OFF, it is received the ignition relay signal (ON) by CAN communication more than 1 second from BCM.	Ignition relay

Diagnosis Procedure

INFOID:000000007353672

1. PERFORM SELF DIAGNOSIS

1. Turn the ignition switch ON.
2. Select "Self Diagnostic Result" of "IPDM E/R". Erase DTC.
3. Turn the ignition switch OFF.
4. Turn the ignition switch ON. Check "Self Diagnostic Result" again.

Is DTC "B2099" displayed?

- YES >> Replace IPDM E/R.
NO >> Refer to [GI-45, "Intermittent Incident"](#).

POWER SUPPLY AND GROUND CIRCUIT

< DTC/CIRCUIT DIAGNOSIS >

[IPDM E/R]

POWER SUPPLY AND GROUND CIRCUIT

Diagnosis Procedure

INFOID:000000007353673

1. CHECK FUSIBLE LINK

Check that the following IPDM E/R fusible link is not blown.

Signal name	Fusible link No.
Battery power supply	C
	E
	K

Is the fusible link fusing?

- YES >> Replace the blown fusible link after repairing the affected circuit if a fusible link is blown.
NO >> GO TO 2.

2. CHECK POWER SUPPLY CIRCUIT

1. Turn the ignition switch OFF.
2. Disconnect IPDM E/R connectors.
3. Check voltage between IPDM E/R harness connectors and the ground.

Terminals		Voltage (Approx.)
(+)	(-)	
IPDM E/R		Battery voltage
Connector	Terminal	
E9	1	
	2	
E10	6	

Is the measurement value normal?

- YES >> GO TO 3.
NO >> Repair the harness or connector.

3. CHECK GROUND CIRCUIT

Check continuity between IPDM E/R harness connectors and the ground.

IPDM E/R		Ground	Continuity
Connector	Terminal		
E11	11		Exist
E13	25		

Does continuity exist?

- YES >> INSPECTION END
NO >> Repair the harness or connector.

A
B
C
D
E
F
G
H
I
J
K
L
N
O
P

PCS

IPDM E/R (INTELLIGENT POWER DISTRIBUTION MODULE ENGINE ROOM)

< ECU DIAGNOSIS INFORMATION >

[IPDM E/R]

ECU DIAGNOSIS INFORMATION

IPDM E/R (INTELLIGENT POWER DISTRIBUTION MODULE ENGINE ROOM)

Reference Value

INFOID:000000007353674

VALUES ON THE DIAGNOSIS TOOL

Monitor Item	Condition		Value/Status
MOTOR FAN REQ	Engine idle speed	Changes depending on engine coolant temperature, air conditioner operation status, vehicle speed, etc.	1 - 4
AC COMP REQ	Engine running	A/C switch OFF	Off
		A/C switch ON (Compressor is operating)	On
TAIL&CLR REQ	Lighting switch OFF		Off
	Lighting switch 1ST or 2ND		On
HL LO REQ	Lighting switch OFF		Off
	Lighting switch 2ND		On
HL HI REQ	Lighting switch OFF		Off
	Lighting switch HI (Light is illuminated)		On
FR FOG REQ NOTE: This item is monitored only on the vehicle with front fog lamp.	Lighting switch 2ND	Front fog lamp switch OFF	Off
		Front fog lamp switch ON	On
FR WIP REQ	Ignition switch ON	Front wiper switch OFF	Stop
		Front wiper switch INT	1LOW
		Front wiper switch LO	Low
		Front wiper switch HI	Hi
WIP AUTO STOP	Ignition switch ON	Front wiper stop position	STOP P
		Any position other than front wiper stop position	ACT P
WIP PROT	Ignition switch ON	Front wiper operates normally	Off
		Front wiper stops at fail-safe operation	BLOCK
ST RLY REQ NOTE: Vehicle without Intelligent Key system indicates only "ON", and it does not change.	When Intelligent Key is outside the vehicle, and the push switch is pushed		Off
	When Intelligent Key is inside the vehicle, and the push switch is pushed		On
IGN RLY	Ignition switch OFF or ACC		Off
	Ignition switch ON		On
RR DEF REQ	Ignition switch ON	Rear window defogger switch OFF	Off
		Rear window defogger switch ON (Rear window defogger is operating)	On
OIL P SW	Ignition switch OFF, ACC or engine running		Open
	Ignition switch ON		Close

IPDM E/R (INTELLIGENT POWER DISTRIBUTION MODULE ENGINE ROOM)

< ECU DIAGNOSIS INFORMATION >

[IPDM E/R]

Monitor Item	Condition	Value/Status
DTRL REQ NOTE: This item is monitored only on the vehicle with the daytime running light system.	Daytime running light system is not operated.	Off
	Daytime running light system is operated.	On
HOOD SW NOTE: This item is monitored only the vehicle for Mexico.	Close the hood	Off
	Open the hood	On
THFT HRN REQ	Not operation	Off
	Horn is activated with vehicle security system or panic alarm system.	On
HORN CHIRP	Not operation	Off
	Horn is activated with key fob LOCK operation.	On

TERMINAL LAYOUT

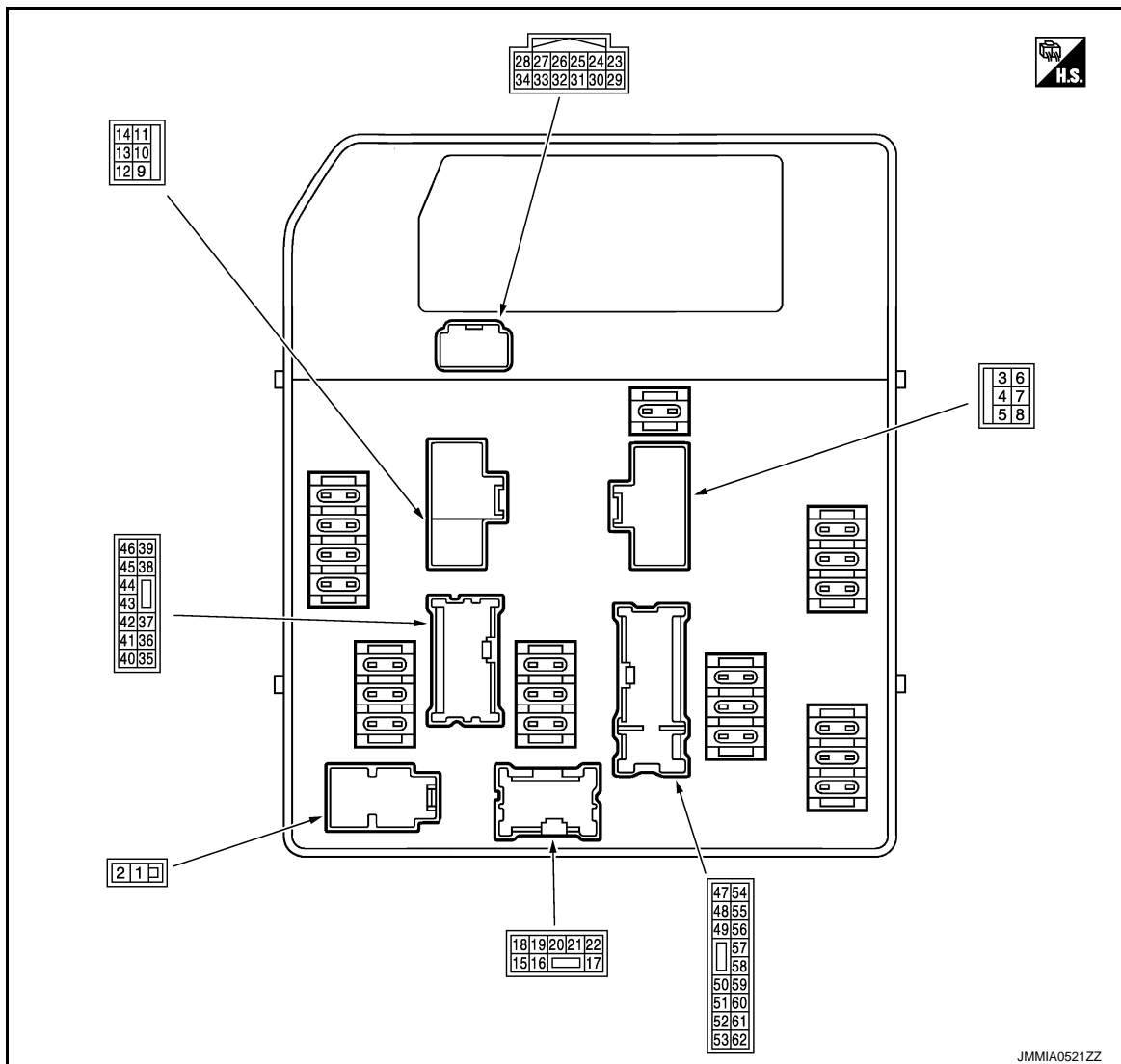

PHYSICAL VALUES

IPDM E/R (INTELLIGENT POWER DISTRIBUTION MODULE ENGINE ROOM)

< ECU DIAGNOSIS INFORMATION >

[IPDM E/R]

Terminal No. (Wire color)		Description		Condition		Value (Approx.)
+	-					
1 (R)	Ground	Battery power supply	Input	Ignition switch OFF		Battery voltage
2 (G)	Ground	Battery power supply	Input	Ignition switch OFF		Battery voltage
3 (L)	Ground	Starter relay power supply	Output	When engine is clanking		Battery voltage
				When engine is not clanking		0 V
4 (W)	Ground	Cooling fan relay-1 power supply	Output	Cooling fan operation	OFF	0 V
					MID or HI	Battery voltage
5 (R)	Ground	Ignition switch START	Input	Ignition switch OFF, ACC or ON		0 V
				Ignition switch START		Battery voltage
6 (BR)	Ground	Battery power supply (Cooling fan relay)	Input	Ignition switch OFF		Battery voltage
7 (P)	Ground	Cooling fan motor-2 (HI) ground	—	Cooling fan operation	OFF	Battery voltage
					HI	0 V
8 (G)	Ground	Cooling fan relay-2 power supply	Output	Cooling fan operation	OFF	0 V
					HI	Battery voltage
11 (B)	Ground	Ground	—	Ignition switch ON		0 V
12 (G)	Ground	Rear window defogger relay power supply	Output	Ignition switch ON	Rear window defogger switch OFF	0 V
					Rear window defogger switch ON	Battery voltage
15*1 (SB)	Ground	Daytime running light relay control	Output	Daytime running light system	Not operated	Battery voltage
					Operated	0 V
16*2 (Y)	Ground	Front fog lamp (LH)	Output	Lighting switch 2ND	Front fog lamp switch OFF	0 V
					Front fog lamp switch ON	Battery voltage
17*2 (W)	Ground	Front fog lamp (RH)	Output	Lighting switch 2ND	Front fog lamp switch OFF	0 V
					Front fog lamp switch ON	Battery voltage
18 (L)	Ground	Headlamp LO (LH)	Output	Lighting switch OFF		0 V
				Lighting switch 2ND		Battery voltage
20 (SB)	Ground	Headlamp LO (RH)	Output	Lighting switch OFF		0 V
				Lighting switch 2ND		Battery voltage
21 (G)	Ground	Headlamp HI (LH)	Output	Lighting switch OFF		0 V
				<ul style="list-style-type: none"> • Lighting switch 2ND and HI • Lighting switch PASS 		Battery voltage
				Daytime running light system Operated*1		7.0 V
22 (LG)	Ground	Headlamp HI (RH)	Output	Lighting switch OFF		0 V
				<ul style="list-style-type: none"> • Lighting switch 2ND and HI • Lighting switch PASS 		Battery voltage
				Daytime running light system Operated*1		7.0 V
23 (W)	Ground	Oil pressure switch	Input	Ignition switch ON	Engine stopped	0 V
					Engine running	Battery voltage
24 (Y)	Ground	Front wiper auto stop	Input	Ignition switch ON	Front wiper stop position	0 V
					Any position other than front wiper stop position	Battery voltage

IPDM E/R (INTELLIGENT POWER DISTRIBUTION MODULE ENGINE ROOM)

< ECU DIAGNOSIS INFORMATION >

[IPDM E/R]

Terminal No. (Wire color)		Description		Condition	Value (Approx.)	
		Signal name	Input/ Output			
+	-					
25 (B)	Ground	Ground	—	Ignition switch ON	0 V	
26 (P)	—	CAN-L	Input/ Output	—	—	
27 (L)	—	CAN-H	Input/ Output	—	—	
31 (LG)	Ground	Cooling fan relay-4 control	Output	Cooling fan operation	OFF LO	Battery voltage 0 - 1.0 V
32 (V)	Ground	Throttle control motor relay control	Input	After passing approximately 2 seconds or more after turning the ignition switch from ON to OFF		Battery voltage
				<ul style="list-style-type: none"> • Ignition switch ON • For approximately 2 seconds after turning ignition switch from ON to OFF 		0 - 1.0 V
33 (GR)	Ground	Fuel pump relay control	Input	Ignition switch OFF		0 V
				Ignition switch ON	Engine stopped	Battery voltage
					Engine running	0.8 V
34*3 (W)	Ground	Hood switch	Input	Close the hood		Battery voltage
				Open the hood		0 V
37 (R)	Ground	Tail, license plate lamps and illuminations	Output	Lighting switch OFF		0 V
				Lighting switch 1ST		Battery voltage
38 (R)	Ground	Parking lamp (LH)	Output	Lighting switch OFF		0 V
				Lighting switch 1ST		Battery voltage
39 (GR)	Ground	Parking lamp (RH)	Output	Lighting switch OFF		0 V
				Lighting switch 1ST		Battery voltage
40 (BR)	Ground	Ignition relay power supply	Output	Ignition switch OFF or ACC		0 V
				Ignition switch ON		Battery voltage
41 (W)	Ground	Ignition relay power supply	Output	Ignition switch OFF or ACC		0 V
				Ignition switch ON		Battery voltage
42 (L)	Ground	Front wiper HI	Output	Ignition switch ON	Front wiper switch OFF	0 V
					Front wiper switch HI	Battery voltage
43 (G)	Ground	Front wiper LO	Output	Ignition switch ON	Front wiper switch OFF	0 V
					Front wiper switch LO	Battery voltage
45 (Y)	Ground	Starter relay power supply	Input	Ignition switch ON	Selector lever "P" or "N"	Battery voltage
					Selector lever in any position other than "P" or "N"	0 V
46 (W)	Ground	Fuel pump relay power supply	Output	<ul style="list-style-type: none"> • Ignition switch OFF or ACC • After passing approximately 1 second or more after turning the ignition switch ON 		0 V
				<ul style="list-style-type: none"> • For approximately 1 second after turning the ignition switch ON • Engine running 		Battery voltage
47 (BR)	Ground	ECM relay power supply	Output	After passing approximately 4 seconds or more after turning the ignition switch from ON to OFF		0 V
				<ul style="list-style-type: none"> • Ignition switch ON • For approximately 4 seconds after turning ignition switch from ON to OFF 		Battery voltage

A
B
C
D
E
F
G
H
I
J
K
L
N
O
P

PCS

IPDM E/R (INTELLIGENT POWER DISTRIBUTION MODULE ENGINE ROOM)

< ECU DIAGNOSIS INFORMATION >

[IPDM E/R]

Terminal No. (Wire color)		Description		Condition	Value (Approx.)	
		Signal name	Input/ Output			
+	-					
48 (R)	Ground	ECM relay power supply	Output	After passing approximately 4 seconds or more after turning the ignition switch from ON to OFF	0 V	
				<ul style="list-style-type: none"> • Ignition switch ON • For approximately 4 seconds after turning ignition switch from ON to OFF 	Battery voltage	
50 (G)	Ground	Cooling fan relay-5 control	Output	Cooling fan operation	Battery voltage	
					OFF MID or HI	0 - 1.0 V
51 (L)	Ground	ECM relay control	Output	After passing approximately 4 seconds or more after turning the ignition switch from ON to OFF	Battery voltage	
				<ul style="list-style-type: none"> • Ignition switch ON • For approximately 4 seconds after turning ignition switch from ON to OFF 	0 - 1.0 V	
52 (P)	Ground	Throttle control motor relay power supply	Output	After passing approximately 2 seconds or more after turning the ignition switch from ON to OFF	0 V	
				<ul style="list-style-type: none"> • Ignition switch ON • For approximately 2 seconds after turning ignition switch from ON to OFF 	Battery voltage	
55 (BG)	Ground	A/C relay power supply	Output	Engine stopped	0 V	
				Engine running	A/C switch OFF	0 V
					A/C switch ON (A/C compressor is operating)	Battery voltage
56 (SB)	Ground	Ignition switch ON	Input	Ignition switch OFF or ACC	0 V	
				Ignition switch ON	Battery voltage	
57 (V)	Ground	Horn relay control	Output	The horn is not activated	Battery voltage	
				The horn is activated	0 V	
58 (LG)	Ground	Ignition relay power supply	Output	Ignition switch OFF or ACC	0 V	
				Ignition switch ON	Battery voltage	
59 (BR)	Ground	Ignition relay power supply	Output	Ignition switch OFF or ACC	0 V	
				Ignition switch ON	Battery voltage	
60 (SB)	Ground	Ignition relay power supply	Output	Ignition switch OFF or ACC	0 V	
				Ignition switch ON	Battery voltage	
61 (R)	Ground	ECM power supply	Output	Ignition switch OFF	Battery voltage	

*1: With daytime running light system

*2: With front fog lamp system

*3: For Mexico

IPDM E/R (INTELLIGENT POWER DISTRIBUTION MODULE ENGINE ROOM)

< ECU DIAGNOSIS INFORMATION >

[IPDM E/R]

Wiring Diagram - IPDM E/R -

INFOID:000000007353675

For connector terminal arrangements, harness layouts, and alphabets in a  (option abbreviation; if not described in wiring diagram), refer to [GI-12, "Connector Information"](#).

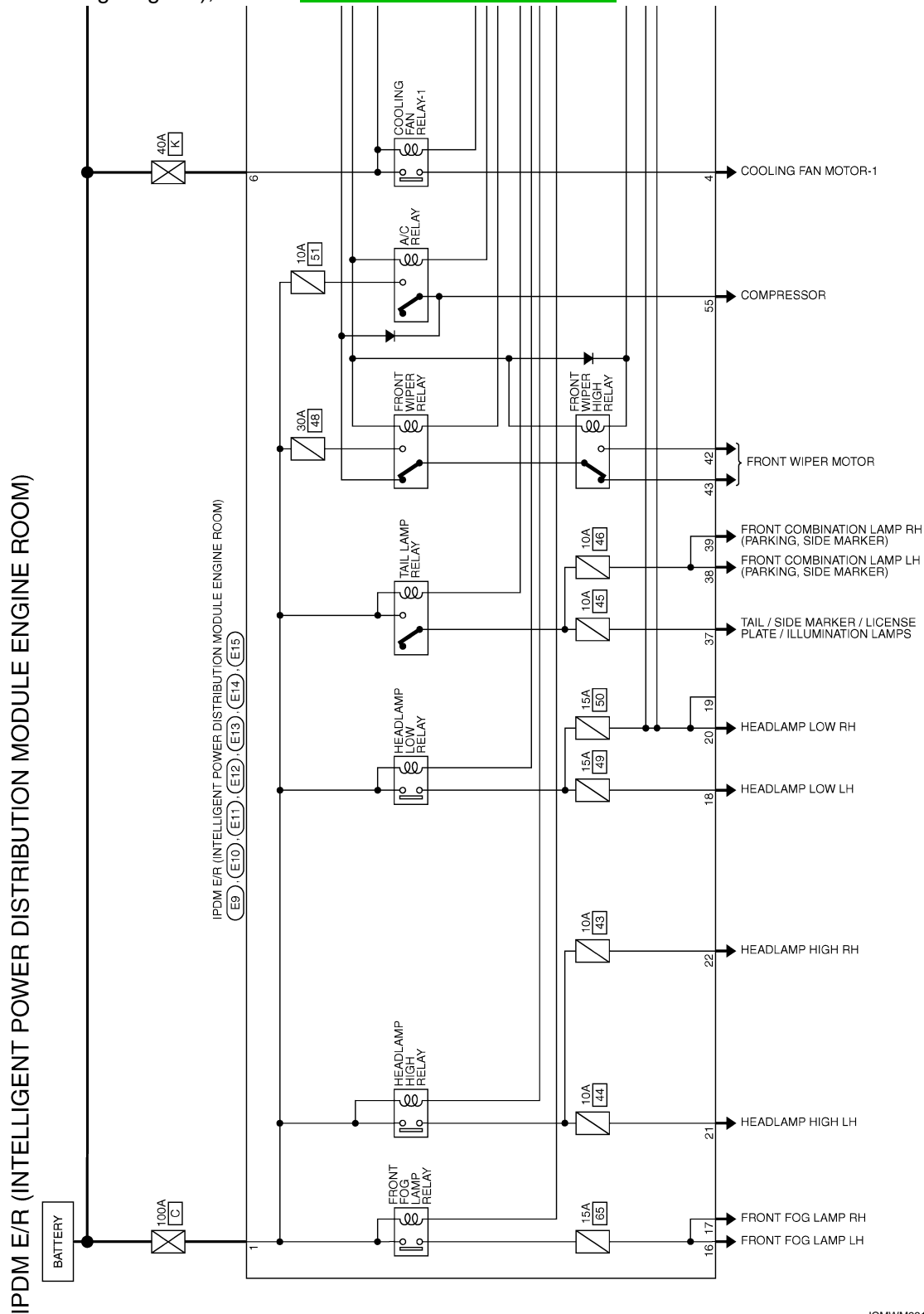

A
B
C
D
E
F
G
H
I
J
K
L
N
O
P

PCS

2010/06/18

JCMWM9312GB

IPDM E/R (INTELLIGENT POWER DISTRIBUTION MODULE ENGINE ROOM)

< ECU DIAGNOSIS INFORMATION >

[IPDM E/R]

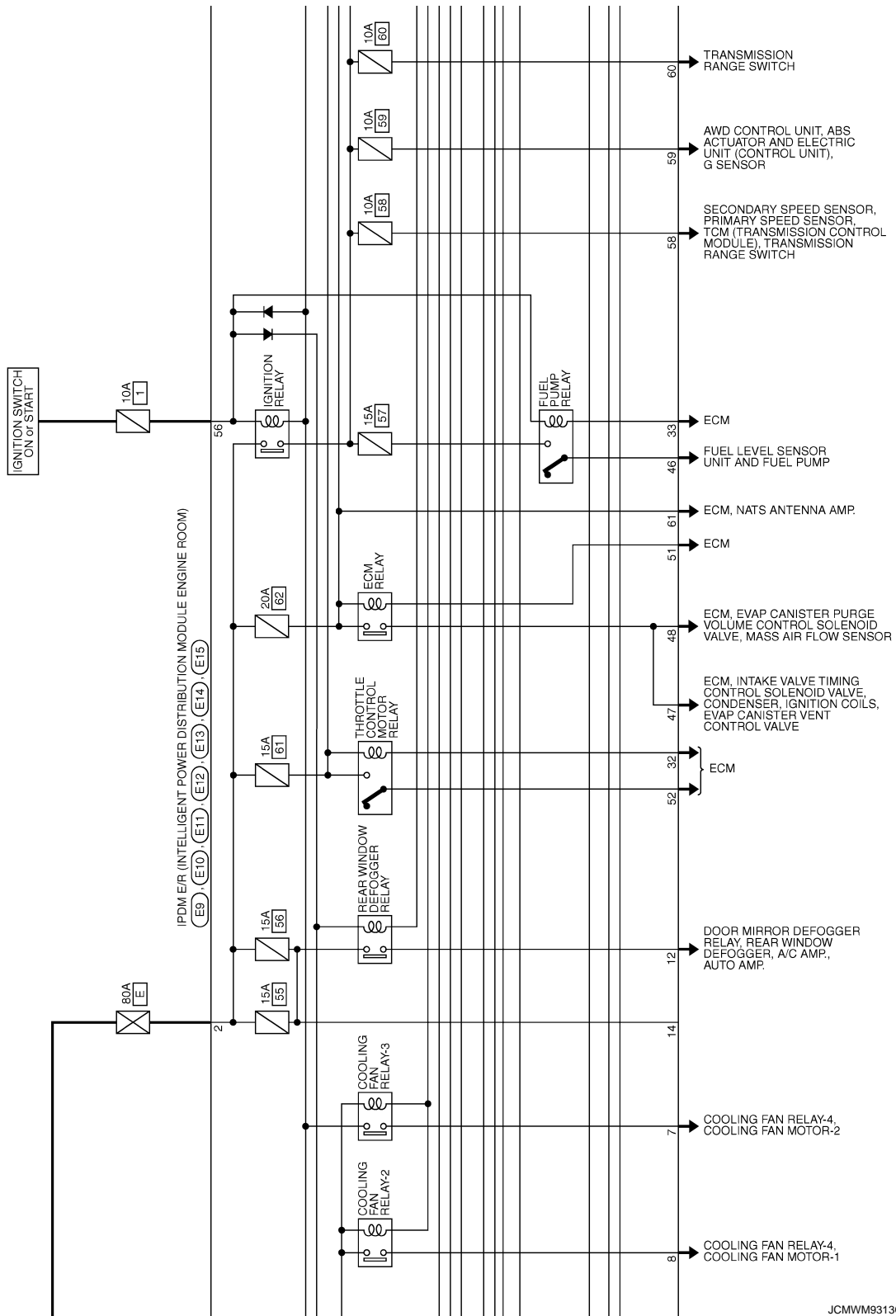

JCMWM9313GB

A
B
C
D
E
F
G
H
I
J
K
L
M
N
O
P

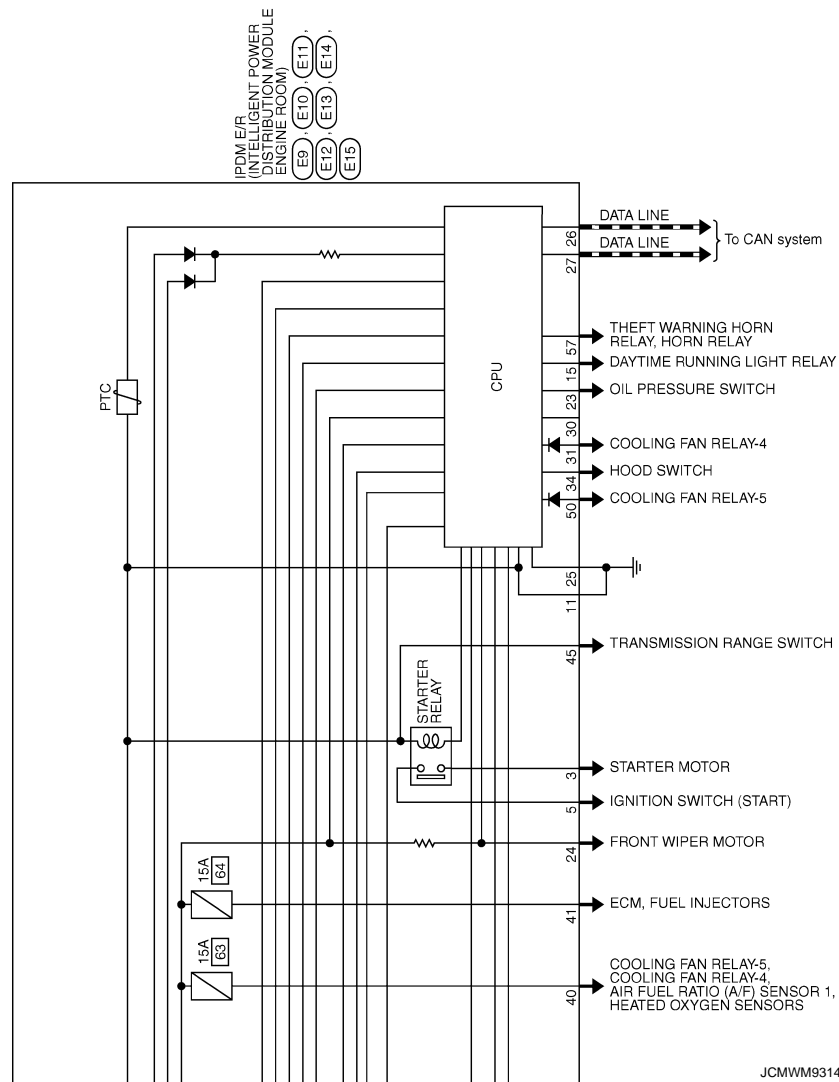

PCS

Fail-safe

INFOID:000000007353676

CAN COMMUNICATION CONTROL

When CAN communication with ECM and BCM is impossible, IPDM E/R performs fail-safe control. After CAN communication recovers normally, it also returns to normal control.

If no CAN communication is available with ECM

IPDM E/R (INTELLIGENT POWER DISTRIBUTION MODULE ENGINE ROOM)

< ECU DIAGNOSIS INFORMATION >

[IPDM E/R]

Control part	Fail-safe in operation
Cooling fan	<ul style="list-style-type: none"> The cooling fan relay-1, the cooling fan relay-2, the cooling fan relay-3 and the cooling fan relay-5 turn ON when the ignition switch is turned ON The cooling fan relay-1, the cooling fan relay-2, the cooling fan relay-3 and the cooling fan relay-5 turn OFF when the ignition switch is turned OFF Cooling fan relay-4 OFF
A/C compressor	A/C relay OFF

If no CAN communication is available with BCM

Control part	Fail-safe in operation
Headlamp	<ul style="list-style-type: none"> The headlamp low relay turns ON when the ignition switch is turned ON The headlamp low relay turns OFF when the ignition switch is turned OFF Headlamp high relay OFF
<ul style="list-style-type: none"> Parking lamps License plate lamps Tail lamps Illuminations 	<ul style="list-style-type: none"> The tail lamp relay and the daytime running light relay* turn ON when the ignition switch is turned ON The tail lamp relay and the daytime running light relay* turn OFF when the ignition switch is turned OFF
Front wiper	<ul style="list-style-type: none"> The status just before activation of fail-safe control is maintained until the ignition switch is turned OFF while the front wiper is operating at LO or HI speed. The front wiper is operated at LO speed until the ignition switch is turned OFF if the fail-safe control is activated while the front wiper is set in the INT mode and the front wiper motor is operating.
Front fog lamps	Front fog lamp relay OFF
Starter motor	Starter relay OFF
Rear window defogger	Rear window defogger relay OFF
Horn	Horn relay OFF

NOTE:

*: With daytime running light system

IGNITION RELAY MALFUNCTION DETECTION FUNCTION

- IPDM E/R monitors status of ignition relay by the voltage at ignition relay contact circuit inside it.
- IPDM E/R judges that the ignition relay is error, if status of the ignition relay and ignition switch ON signal (CAN).
- If the ignition relay cannot turn OFF due to contact seizure, it activates the tail lamp relay and daytime running light relay* for 10 minutes to alert the user to the ignition relay malfunction when the ignition switch is turned OFF.

Detection		IPDM E/R judgment	Operation
Ignition switch ON signal	Ignition relay		
ON	ON	Ignition relay normal	—
OFF	OFF	Ignition relay normal	—
OFF	ON	Ignition relay ON stuck	Turn on the tail lamp relay and daytime running light relay* for 10 minutes
ON	OFF	Ignition relay OFF stuck	Detect DTC "B2099: IGN RELAY OFF"

NOTE:

*: With daytime running light system

FRONT WIPER CONTROL

IPDM E/R detects the front wiper stop position with the front wiper stop position signal.

When the front wiper stop position signal is in the conditions listed below, IPDM E/R repeats a front wiper 10 seconds operation and 20 seconds stop five times.

IPDM E/R (INTELLIGENT POWER DISTRIBUTION MODULE ENGINE ROOM)

< ECU DIAGNOSIS INFORMATION >

[IPDM E/R]

Ignition switch	Front wiper switch	Front wiper stop position signal
ON	OFF	The front wiper stop position signal (stop position) cannot be input for 10 seconds.
	ON	The front wiper stop position signal does not change for 10 seconds.

NOTE:

This operation status can be confirmed on the IPDM E/R “Data Monitor” that displays “BLOCK” for the item “WIP PROT” while the wiper is stopped.

DTC Index

INFOID:000000007353677

CONSULT display	Fail-safe	Timing ^{NOTE}		Reference page
No DTC is detected. further testing may be required.	—	—	—	—
U1000: CAN COMM CIRCUIT	×	CRNT	PAST	PCS-13
B2099: IGN RELAY OFF	—	CRNT	PAST	PCS-14

NOTE:

The details of time display are as follows.

- CRNT: The malfunctions that are detected now.
- PAST: The number is indicated when it is normal at present and a malfunction was detected in the past.

A
B
C
D
E
F
G
H
I
J
K
L
N
O
P

PCS

< PRECAUTION >

PRECAUTION**PRECAUTIONS****FOR USA AND CANADA****FOR USA AND CANADA : Precaution for Supplemental Restraint System (SRS) "AIR BAG" and "SEAT BELT PRE-TENSIONER"**

INFOID:000000007353678

The Supplemental Restraint System such as "AIR BAG" and "SEAT BELT PRE-TENSIONER", used along with a front seat belt, helps to reduce the risk or severity of injury to the driver and front passenger for certain types of collision. This system includes seat belt switch inputs and dual stage front air bag modules. The SRS system uses the seat belt switches to determine the front air bag deployment, and may only deploy one front air bag, depending on the severity of a collision and whether the front occupants are belted or unbelted.

Information necessary to service the system safely is included in the "SRS AIR BAG" and "SEAT BELT" of this Service Manual.

WARNING:

- To avoid rendering the SRS inoperative, which could increase the risk of personal injury or death in the event of a collision that would result in air bag inflation, all maintenance must be performed by an authorized NISSAN/INFINITI dealer.
- Improper maintenance, including incorrect removal and installation of the SRS, can lead to personal injury caused by unintentional activation of the system. For removal of Spiral Cable and Air Bag Module, see the "SRS AIR BAG".
- Do not use electrical test equipment on any circuit related to the SRS unless instructed to in this Service Manual. SRS wiring harnesses can be identified by yellow and/or orange harnesses or harness connectors.

PRECAUTIONS WHEN USING POWER TOOLS (AIR OR ELECTRIC) AND HAMMERS**WARNING:**

- When working near the Air Bag Diagnosis Sensor Unit or other Air Bag System sensors with the ignition ON or engine running, DO NOT use air or electric power tools or strike near the sensor(s) with a hammer. Heavy vibration could activate the sensor(s) and deploy the air bag(s), possibly causing serious injury.
- When using air or electric power tools or hammers, always switch the ignition OFF, disconnect the battery, and wait at least 3 minutes before performing any service.

FOR MEXICO**FOR MEXICO : Precaution for Supplemental Restraint System (SRS) "AIR BAG" and "SEAT BELT PRE-TENSIONER"**

INFOID:000000007353679

The Supplemental Restraint System such as "AIR BAG" and "SEAT BELT PRE-TENSIONER", used along with a front seat belt, helps to reduce the risk or severity of injury to the driver and front passenger for certain types of collision. Information necessary to service the system safely is included in the "SRS AIR BAG" and "SEAT BELT" of this Service Manual.

WARNING:

- To avoid rendering the SRS inoperative, which could increase the risk of personal injury or death in the event of a collision which would result in air bag inflation, all maintenance must be performed by an authorized NISSAN/INFINITI dealer.
- Improper maintenance, including incorrect removal and installation of the SRS, can lead to personal injury caused by unintentional activation of the system. For removal of Spiral Cable and Air Bag Module, see the "SRS AIR BAG".
- Do not use electrical test equipment on any circuit related to the SRS unless instructed to in this Service Manual. SRS wiring harnesses can be identified by yellow and/or orange harnesses or harness connectors.

PRECAUTIONS WHEN USING POWER TOOLS (AIR OR ELECTRIC) AND HAMMERS**WARNING:**

- When working near the Air Bag Diagnosis Sensor Unit or other Air Bag System sensors with the ignition ON or engine running, DO NOT use air or electric power tools or strike near the sensor(s)

PRECAUTIONS

[IPDM E/R]

< PRECAUTION >

- with a hammer. Heavy vibration could activate the sensor(s) and deploy the air bag(s), possibly causing serious injury.
- When using air or electric power tools or hammers, always switch the ignition OFF, disconnect the battery, and wait at least 3 minutes before performing any service.

A

B

C

D

E

F

G

H

I

J

K

L

PCS

N

O

P

REMOVAL AND INSTALLATION

IPDM E/R (INTELLIGENT POWER DISTRIBUTION MODULE ENGINE ROOM)

Exploded View

INFOID:000000007353680

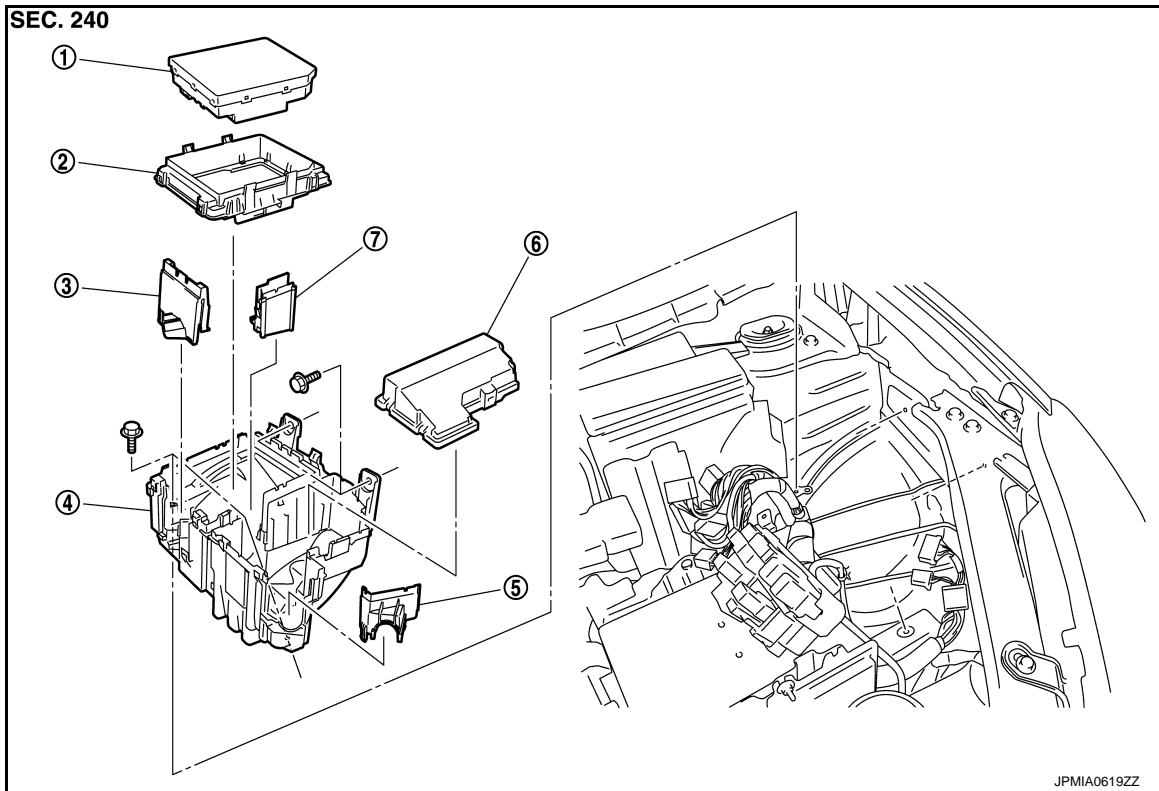

- | | | |
|---------------------|---------------------|--------------------------------------|
| 1. IPDM E/R | 2. IPDM E/R bracket | 3. IPDM E/R cover A |
| 4. IPDM E/R cover B | 5. Harness cover A | 6. Fuse and fusible link block cover |
| 7. Harness cover B | | |

Removal and Installation

INFOID:000000007353681

CAUTION:

IPDM E/R integrated relays are not serviceable parts, and must not be removed from the unit.

REMOVAL

1. Remove air duct (inlet). Refer to [EM-29, "Exploded View"](#).
2. Remove battery. Refer to [PG-102, "Exploded View"](#).
3. Remove IPDM E/R (1) while pushing and opening pawls (A).
4. Disconnect connectors from IPDM E/R.

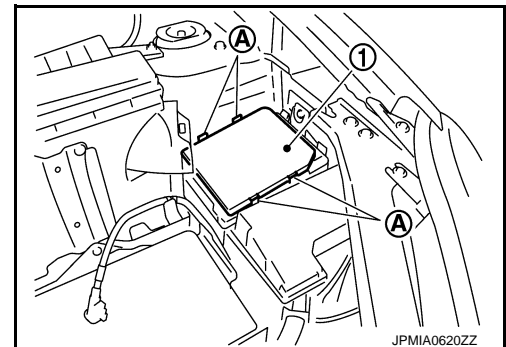

5. Remove fuse and fusible link block cover.

IPDM E/R (INTELLIGENT POWER DISTRIBUTION MODULE ENGINE ROOM)

< REMOVAL AND INSTALLATION >

[IPDM E/R]

6. Unlock all pawls (A) of IPDM E/R bracket, and remove IPDM E/R bracket (1).

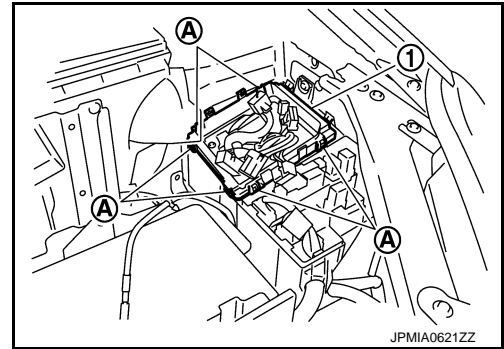

7. Unlock pawls of IPDM E/R cover A, harness cover A and harness cover B, remove them.
8. Disconnect connectors connected to fuse and fusible link block upper side, and remove fuse and fusible link block.
9. Remove IPDM E/R cover B mounting bolts (A) and battery cable fixed clip (B), and remove IPDM E/R cover B (1).

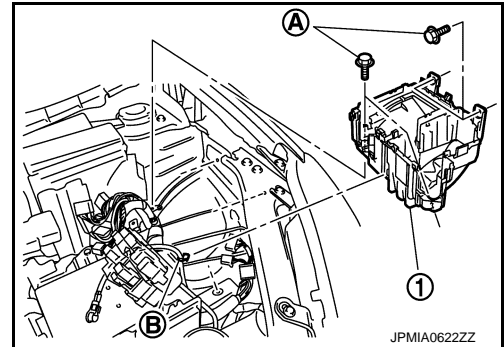

INSTALLATION

Install in the reverse order of removal.

A
B
C
D
E
F
G
H
I
J
K
L
N
O
P

PCS