

SECTION **DEF**
DEFOGGER

A
B
C
D
E
F
G
H
I
J
K
DEF
M
N
O
P

CONTENTS

BASIC INSPECTION	3	DOOR MIRROR DEFOGGER RELAY	18
DIAGNOSIS AND REPAIR WORK FLOW	3	Component Function Check	18
Work Flow	3	Diagnosis Procedure	18
SYSTEM DESCRIPTION	4	Component Inspection	19
REAR WINDOW DEFOGGER SYSTEM	4	REAR WINDOW DEFOGGER	20
System Diagram	4	Component Function Check	20
System Description	4	Diagnosis Procedure	20
Component Parts Location	5	DRIVER SIDE DOOR MIRROR DEFOGGER ...	22
Component Description	5	Component Function Check	22
DIAGNOSIS SYSTEM (BCM)	7	Diagnosis Procedure	22
COMMON ITEM	7	PASSENGER SIDE DOOR MIRROR DEFOGGER	24
COMMON ITEM : CONSULT Function (BCM -		Component Function Check	24
COMMON ITEM)	7	Diagnosis Procedure	24
REAR WINDOW DEFOGGER	7	REAR WINDOW DEFOGGER FEEDBACK	
REAR WINDOW DEFOGGER : CONSULT Func-		SIGNAL	26
tion (BCM - REAR DEFOGGER)	8	WITH AUTO A/C	26
DIAGNOSIS SYSTEM (IPDM E/R)	9	WITH AUTO A/C : Component Function Check	26
Diagnosis Description	9	WITH AUTO A/C : Diagnosis Procedure	26
CONSULT Function (IPDM E/R)	11	WITH MANUAL A/C	26
DTC/CIRCUIT DIAGNOSIS	14	WITH MANUAL A/C : Component Function Check	27
REAR WINDOW DEFOGGER SWITCH	14	27
WITH AUTO A/C	14	WITH MANUAL A/C : Diagnosis Procedure	27
WITH AUTO A/C : Component Function Check	14	REAR WINDOW DEFOGGER SYSTEM	28
WITH AUTO A/C : Diagnosis Procedure	14	Wiring Diagram - REAR WINDOW DEFOGGER	
WITH MANUAL A/C	15	SYSTEM -	28
WITH MANUAL A/C : Component Function Check	15	ECU DIAGNOSIS INFORMATION	29
.....	15	BCM, IPDM E/R	29
WITH MANUAL A/C : Diagnosis Procedure	15	List of ECU Reference	29
REAR WINDOW DEFOGGER RELAY	17	SYMPTOM DIAGNOSIS	30
Component Function Check	17	REAR WINDOW DEFOGGER DOES NOT	
Diagnosis Procedure	17	OPERATE	30

Description	30	REAR WINDOW DEFOGGER INDICATOR	
Diagnosis Procedure	30	DOES NOT ILLUMINATE	35
		Diagnosis Procedure	35
REAR WINDOW DEFOGGER AND DOOR		PRECAUTION	36
MIRROR DEFOGGERS DO NOT OPERATE ...	31	PRECAUTIONS	36
Description	31	FOR USA AND CANADA	36
Diagnosis Procedure	31	FOR USA AND CANADA : Precaution for Supplemental Restraint System (SRS) "AIR BAG" and "SEAT BELT PRE-TENSIONER"	36
		FOR USA AND CANADA : Precaution for Procedure without Cowl Top Cover	36
REAR WINDOW DEFOGGER DOES NOT OPERATE BUT BOTH DOOR MIRROR DEFOGGERS OPERATE	32	FOR USA AND CANADA : Precautions For Xenon Headlamp Service	36
Description	32	FOR MEXICO	37
Diagnosis Procedure	32	FOR MEXICO : Precaution for Supplemental Restraint System (SRS) "AIR BAG" and "SEAT BELT PRE-TENSIONER"	37
		FOR MEXICO : Precaution for Procedure without Cowl Top Cover	37
DOOR MIRROR DEFOGGER DOES NOT OPERATE	33	FOR MEXICO : Precautions For Xenon Headlamp Service	37
BOTH SIDE	33	REMOVAL AND INSTALLATION	39
BOTH SIDE : Description	33	FILAMENT	39
BOTH SIDE : Diagnosis Procedure	33	Inspection and Repair	39
DRIVER SIDE	33		
DRIVER SIDE : Description	33		
DRIVER SIDE : Diagnosis Procedure	33		
PASSENGER SIDE	33		
PASSENGER SIDE : Description	33		
PASSENGER SIDE : Diagnosis Procedure	33		

DIAGNOSIS AND REPAIR WORK FLOW

< BASIC INSPECTION >

BASIC INSPECTION

DIAGNOSIS AND REPAIR WORK FLOW

Work Flow

INFOID:000000008278350

DETAILED FLOW

1.OBTAIN INFORMATION ABOUT SYMPTOM

Interview the customer to obtain the malfunction information (conditions and environment when the malfunction occurred) as much as possible when the customer brings the vehicle in.

>> GO TO 2.

2.CHECK DTC

Perform self diagnosis with CONSULT

Is any DTC detected?

YES >> Refer to [BCS-61, "DTC Index"](#).

NO >> GO TO 3.

3.REPRODUCE THE MALFUNCTION INFORMATION

Check the malfunction on the vehicle that the customer describes.
Inspect the relation of the symptoms and the condition when the symptoms occur.

>> GO TO 4.

4.IDENTIFY THE MALFUNCTIONING SYSTEM WITH "SYMPTOM DIAGNOSIS"

Use "Symptom diagnosis" from the symptom inspection result in step 3. Then identify where to start performing the diagnosis based on possible causes and symptoms.

>> GO TO 5.

5.IDENTIFY THE MALFUNCTIONING PARTS WITH "COMPONENT DIAGNOSIS"

Perform the diagnosis with "Component diagnosis" of the applicable system.

>> GO TO 6.

6.REPAIR OR REPLACE THE MALFUNCTIONING PARTS

Repair or replace the specified malfunctioning parts.

>> GO TO 7.

7.FINAL CHECK

Check that malfunctions are not reproduced when obtaining the malfunction information from the customer, referring to the symptom inspection result in step 3.

Are all malfunctions corrected?

YES >> INSPECTION END

NO >> GO TO 4.

A
B
C
D
E
F
G
H
I
J
K
DEF
M
N
O
P

REAR WINDOW DEFOGGER SYSTEM

< SYSTEM DESCRIPTION >

SYSTEM DESCRIPTION

REAR WINDOW DEFOGGER SYSTEM

System Diagram

INFOID:000000008278351

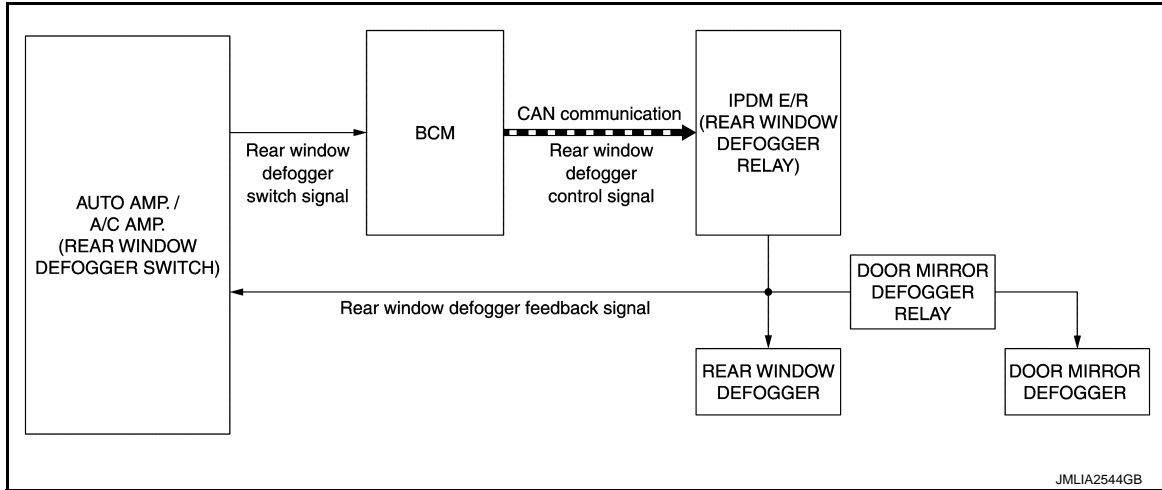

System Description

INFOID:000000008278352

OPERATION DESCRIPTION

- BCM detects that rear window defogger switch is turned ON while ignition switch is ON, and then transmits rear window defogger control signal to IPDM E/R via CAN communication for approximately 15 minutes.
- IPDM E/R turns rear window defogger relay ON when it receives the rear window defogger control signal.
- The power is supplied to the rear window defogger and door mirror defogger relay (with door mirror defogger) when the rear window defogger relay is turned ON.

TIMER FUNCTION

- BCM transmits the rear window defogger control signal to IPDM E/R for approximately 15 minutes when rear window defogger switch is turned ON with ignition switch ON. Then, IPDM E/R operates the rear window defogger and door mirror defogger (with door mirror defogger).
- The timer is cancelled if the rear window defogger switch is pressed again during timer operation. Then BCM stops the output of rear window defogger control signal. The same reaction also occurs during timer operation if the ignition switch is turned OFF.

REAR WINDOW DEFOGGER SYSTEM

< SYSTEM DESCRIPTION >

Component Parts Location

INFOID:000000008278353

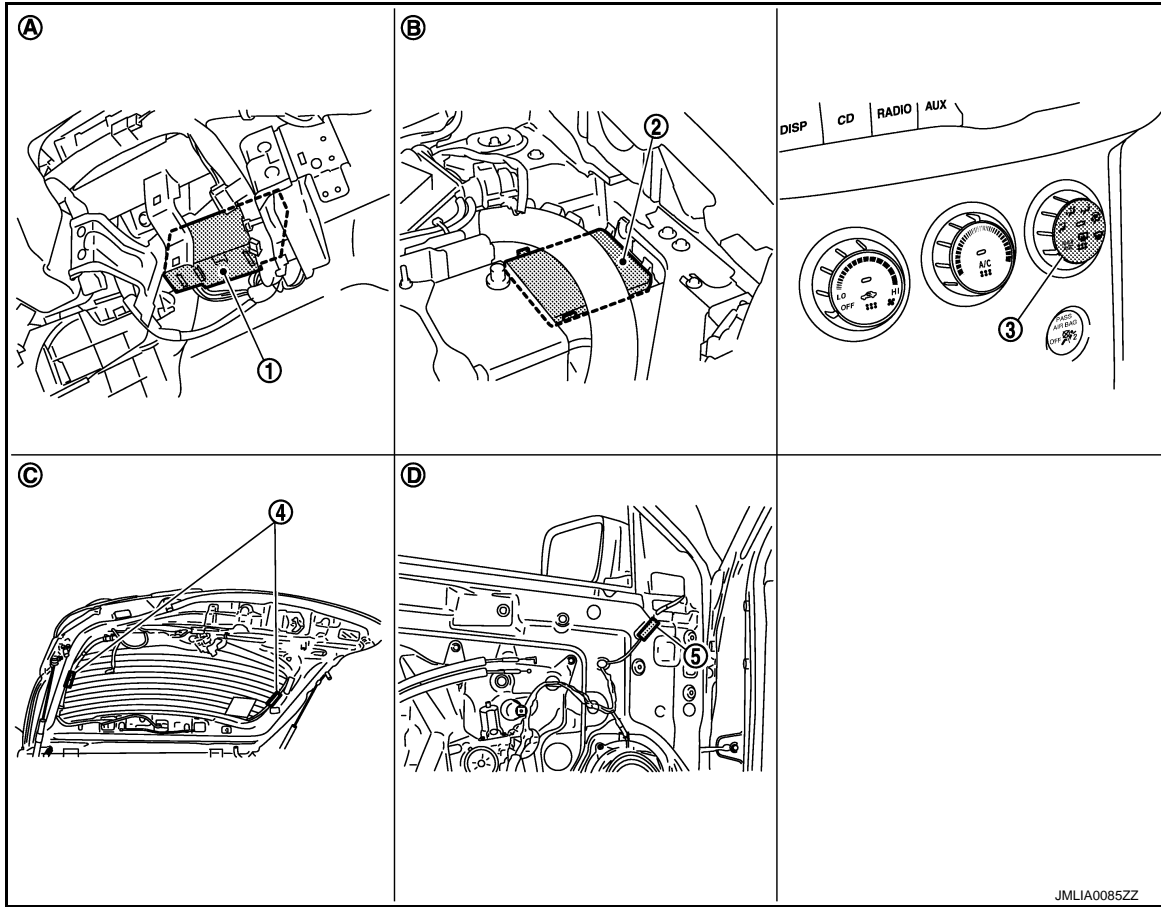

- | | | |
|-------------------------------|-------------------------|---|
| 1. BCM | 2. IPDM E/R | 3. Rear window defogger switch
(built in AUTO amp.)* ¹
(built in A/C amp.)* ² |
| 4. Rear window defogger | 5. Door mirror defogger | |
| A. Behind glove box | B. Engine room (LH) | C. Behind back door side finisher |
| D. Behind front door finisher | | |

*1: For models with auto A/C

*2: For models with manual A/C

Component Description

INFOID:000000008278354

BCM	<ul style="list-style-type: none"> • Detects rear window defogger switch signal and transmits rear window defogger control signal to IPDM E/R. • Performs the timer control of rear window defogger.
Rear window defogger relay	Operates the rear window defogger and the door mirror defogger relay with IPDM E/R control.
Door mirror defogger relay	Operates the door mirror defogger with IPDM E/R (rear window defogger relay) control.
IPDM E/R	<ul style="list-style-type: none"> • Rear window defogger relay is installed. • Receives rear window defogger control signal from BCM via CAN communication. • Controls rear window defogger relay and door mirror defogger relay.
AUTO amp.* ¹ A/C amp.* ² (Rear window defogger switch)	<ul style="list-style-type: none"> • The rear window defogger switch is installed. • Turns the indicator lamp ON when detecting the operation of rear window defogger.

A
B
C
D
E
F
G
H
I
J
K

DEF

M
N
O
P

REAR WINDOW DEFOGGER SYSTEM

< SYSTEM DESCRIPTION >

Rear window defogger	Heats the heating wire with the power supply from the rear window defogger relay to prevent the rear window from fogging up.
Door mirror defogger	Heats the heating wire with the power supply from the rear window defogger relay to prevent the door mirror from fogging up.

*1: For models with auto A/C

*2: For models with manual A/C

DIAGNOSIS SYSTEM (BCM)

< SYSTEM DESCRIPTION >

DIAGNOSIS SYSTEM (BCM)

COMMON ITEM

COMMON ITEM : CONSULT Function (BCM - COMMON ITEM)

INFOID:000000008278355

APPLICATION ITEM

CONSULT can display each diagnostic item using the diagnostic test modes shown following.

Diagnosis mode	Function description
ECU Identification	BCM part number is displayed.
Self-Diagnostic Result	Displays the diagnosis results judged by BCM. Refer to BCS-61, "DTC Index" .
Data Monitor	BCM input/output signals are displayed.
Active Test	The signals used to activate each device are forcibly supplied from BCM.
Work Support	Changes the setting for each system function.
Configuration	<ul style="list-style-type: none"> Read and save the vehicle specification. Write the vehicle specification when replacing BCM.
CAN Diag Support Monitor	Monitors the reception status of CAN communication viewed from BCM.

SYSTEM APPLICATION

BCM can perform the following functions for each system.

NOTE:

It can perform the diagnosis modes except the following for all sub system selection items.

×: Applicable item

System	CONSULT sub system selection item	Diagnosis mode		
		Work Support	Data Monitor	Active Test
Door lock	DOOR LOCK	×	×	×
Rear window defogger	REAR DEFOGGER		×	×
Warning chime	BUZZER		×	×
Interior room lamp control	INT LAMP	×	×	×
Remote keyless entry system	MULTI REMOTE ENT	×	×	×
Exterior lamp	HEAD LAMP	×	×	×
Wiper and washer	WIPER	×	×	×
Turn signal and hazard warning lamps	FLASHER		×	×
<ul style="list-style-type: none"> Auto air conditioning system Manual air conditioning system 	AIR CONDITONER		×	
Intelligent Key system	INTELLIGENT KEY		×	
Combination switch	COMB SW		×	
Body control system	BCM	×		
Immobilizer	IMMU		×	×
Interior room lamp battery saver	BATTERY SAVER	×	×	×
Back door open	TRUNK		×	×
Vehicle security system	THEFT ALM	×	×	×
RAP system	RETAINED PWR	×	×	×
Signal buffer system	SIGNAL BUFFER		×	×
—	FUEL LID*			
TPMS	AIR PRESSURE MONITOR	×	×	×
Panic alarm system	PANIC ALARM			×

*: This item is displayed, but is not function.

REAR WINDOW DEFOGGER

DIAGNOSIS SYSTEM (BCM)

< SYSTEM DESCRIPTION >

REAR WINDOW DEFOGGER : CONSULT Function (BCM - REAR DEFOGGER)

INFOID:000000008278356

Data monitor

Monitor Item	Description
REAR DEF SW	Displays "Press (ON)/other (OFF)" status determined with the rear window defogger switch.
IGN ON SW	Indicates [ON/OFF] condition of ignition switch in ON position.
ACC ON SW	Indicates [ON/OFF] condition of ignition switch in ACC position.

ACTIVE TEST

Test Item	Description
REAR DEFOGGER	This test is able to check rear window defogger operation.

DIAGNOSIS SYSTEM (IPDM E/R)

< SYSTEM DESCRIPTION >

DIAGNOSIS SYSTEM (IPDM E/R)

Diagnosis Description

INFOID:000000008278357

Auto active test

Description

In auto active test mode, the IPDM E/R sends a drive signal to the following systems to check their operation.

- Oil pressure warning lamp
- Rear window defogger
- Front wiper (LO, HI)
- Parking lamp
- License plate lamp
- Tail lamp
- Side marker lamp
- Front fog lamp
- Headlamp (LO, HI)
- A/C compressor (magnet clutch)
- Cooling fan (LO, MID, HI)

Operation procedure

1. Close the hood and lift the wiper arms from the windshield. (Prevent windshield damage due to wiper operation)

NOTE:

When auto active test is performed with hood opened, sprinkle water on windshield beforehand.

2. Turn the ignition switch OFF.
3. Turn the ignition switch ON, and within 20 seconds, press the driver door switch 10 times. Then turn the ignition switch OFF.

CAUTION:

Close passenger door.

4. Turn the ignition switch ON within 10 seconds. Then the horn sounds once and the auto active test starts.

NOTE:

Only a vehicle with the vehicle security system, the horn sounds.

5. The oil pressure warning lamp starts blinking when the auto active test starts.
6. After a series of the following operations is repeated 3 times, auto active test is completed.

NOTE:

When auto active test mode has to be cancelled halfway through test, turn the ignition switch OFF.

CAUTION:

- **If auto active test mode cannot be actuated, check door switch system.**
- **Never start the engine.**

Inspection in auto active test mode

When auto active test mode is actuated, the following 6 steps are repeated 3 times.

Operation sequence	Inspection location	Operation
A	Oil pressure warning lamp	Blinks continuously during operation of auto active test.
1	Rear window defogger	10 seconds
2	Front wiper motor	LO for 5 seconds → HI for 5 seconds
3	<ul style="list-style-type: none">• Parking lamp• License plate lamp• Tail lamp• Side marker lamp• Front fog lamp• Headlamps HI (daytime running light operation)*	10 seconds
4	Headlamp	LO 10 seconds → ⇔ OFF 5 times
5	A/C compressor (magnet clutch)	ON ⇔ OFF 5 times
6	Cooling fan	LO for 5 seconds → MID for 3 seconds → HI for 2 seconds

DIAGNOSIS SYSTEM (IPDM E/R)

< SYSTEM DESCRIPTION >

NOTE:

*: With daytime running light system

Concept of auto active test

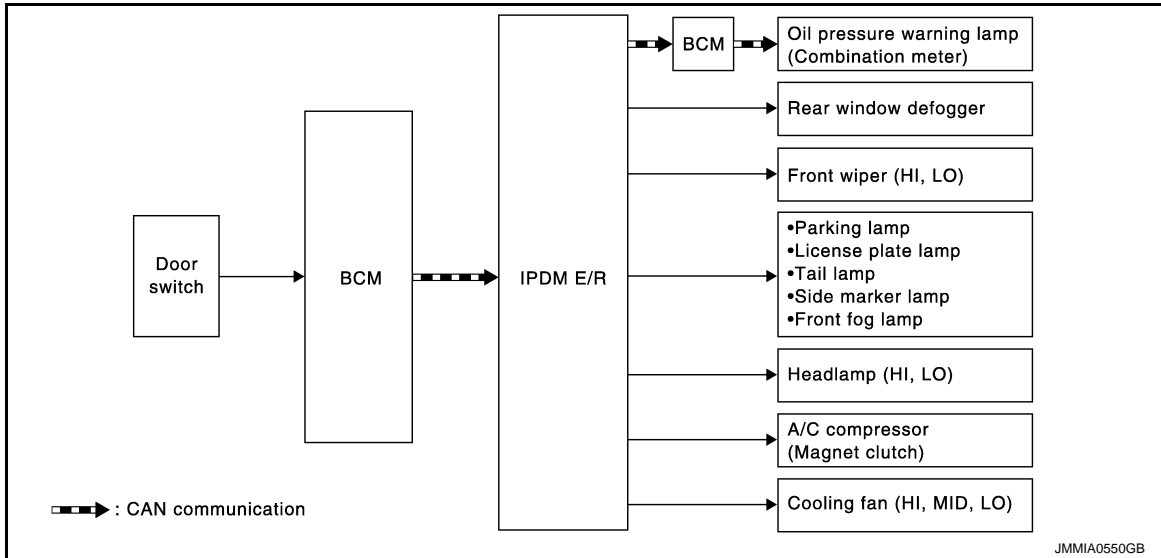

- IPDM E/R starts the auto active test with the door switch signals transmitted by BCM via CAN communication. Therefore, the CAN communication line between IPDM E/R and BCM is considered normal if the auto active test starts successfully.
- The auto active test facilitates troubleshooting if any systems controlled by IPDM E/R cannot be operated.

Diagnosis chart in auto active test mode

Symptom	Inspection contents	Possible cause
Rear window defogger does not operate	Perform auto active test. Does the rear window defogger operate?	YES BCM signal input circuit
		NO <ul style="list-style-type: none"> • Rear window defogger • Rear window defogger ground circuit • Harness or connector between IPDM E/R and rear window defogger • IPDM E/R
Any of the following components do not operate <ul style="list-style-type: none"> • Parking lamp • License plate lamp • Tail lamp • Side marker lamp • Front fog lamp • Headlamp (HI, LO) • Front wiper motor (HI, LO) 	Perform auto active test. Does the applicable system operate?	YES BCM signal input circuit
		NO <ul style="list-style-type: none"> • Lamp or motor • Lamp or motor ground circuit • Harness or connector between IPDM E/R and applicable system • IPDM E/R
Headlamps HI (daytime running light operation) do not operate	Perform auto active test. Do headlamps HI (daytime running light operation) operate?	YES <ul style="list-style-type: none"> • CAN communication signal between ECM and BCM • CAN communication signal between combination meter and BCM • BCM signal input circuit
		NO <ul style="list-style-type: none"> • Daytime running light relay power supply circuit • Harness or connector between IPDM E/R and daytime running light relay • Daytime running light relay

DIAGNOSIS SYSTEM (IPDM E/R)

< SYSTEM DESCRIPTION >

Symptom	Inspection contents		Possible cause
A/C compressor does not operate	Perform auto active test. Does the magnet clutch operate?	YES	<ul style="list-style-type: none"> • BCM signal input circuit • CAN communication signal between BCM and ECM • CAN communication signal between ECM and IPDM E/R
		NO	<ul style="list-style-type: none"> • Magnet clutch • Harness or connector between IPDM E/R and magnet clutch • IPDM E/R
Oil pressure warning lamp does not operate	Perform auto active test. Does the oil pressure warning lamp blink?	YES	<ul style="list-style-type: none"> • Harness or connector between IPDM E/R and oil pressure switch • Oil pressure switch • IPDM E/R
		NO	<ul style="list-style-type: none"> • CAN communication signal between IPDM E/R and BCM • CAN communication signal between BCM and combination meter • Combination meter
Cooling fan does not operate	Perform auto active test. Does the cooling fan operate?	YES	<ul style="list-style-type: none"> • ECM signal input circuit • CAN communication signal between ECM and IPDM E/R
		NO	<ul style="list-style-type: none"> • Cooling fan motor-2 power supply circuit • Cooling fan motor-1 ground circuit • Cooling fan relay-4 or cooling fan relay-5 power supply circuit • Cooling fan relay-5 ground circuit • Harness or connector between IPDM E/R and cooling fan motor • Harness or connector between IPDM E/R, and cooling fan relay-4 or cooling fan relay-5 • Harness or connector between cooling fan motor-2, and cooling fan relay-4 or cooling fan relay-5 • Cooling fan relay-4 or cooling fan relay-5 • Cooling fan motor • IPDM E/R

A
B
C
D
E
F
G
H
I
J
K
DEF

CONSULT Function (IPDM E/R)

INFOID:000000008278358

APPLICATION ITEM

CONSULT performs the following functions via CAN communication with IPDM E/R.

Diagnosis mode	Description
Self Diagnostic Result	Displays the diagnosis results judged by IPDM E/R.
Data Monitor	Displays the real-time input/output data from IPDM E/R input/output data.
Active Test	IPDM E/R can provide a drive signal to electronic components to check their operations.
CAN Diag Support Monitor	The results of transmit/receive diagnosis of CAN communication can be read.

SELF DIAGNOSTIC

Refer to [PCS-25. "DTC Index"](#).

DATA MONITOR

Monitor item

M
N
O
P

DIAGNOSIS SYSTEM (IPDM E/R)

< SYSTEM DESCRIPTION >

Monitor Item [Unit]	MAIN SIGNALS	Description
MOTOR FAN REQ [1 - 4]	×	Displays the value of the cooling fan speed signal received from ECM via CAN communication.
AC COMP REQ [Off/On]	×	Displays the status of the A/C compressor request signal received from ECM via CAN communication.
TAIL&CLR REQ [Off/On]	×	Displays the status of the position light request signal received from BCM via CAN communication.
HL LO REQ [Off/On]	×	Displays the status of the low beam request signal received from BCM via CAN communication.
HL HI REQ [Off/On]	×	Displays the status of the high beam request signal received from BCM via CAN communication.
FR FOG REQ [Off/On]	×	Displays the status of the front fog light request signal received from BCM via CAN communication. NOTE: This item is monitored only the vehicle with front fog lamp system.
FR WIP REQ [Stop/1LOW/Low/Hi]	×	Displays the status of the front wiper request signal received from BCM via CAN communication.
WIP AUTO STOP [STOP P/ACT P]	×	Displays the status of the front wiper stop position signal judged by IPDM E/R.
WIP PROT [Off/BLOCK]	×	Displays the status of the front wiper fail-safe operation judged by IPDM E/R.
ST RLY REQ [Off/On]		Displays the status of the starter request signal.
IGN RLY [Off/On]	×	Displays the status of the ignition relay judged by IPDM E/R.
RR DEF REQ [Off/On]	×	Displays the status of the rear defogger request signal received from BCM via CAN communication.
OIL P SW [Open/Close]		Displays the status of the oil pressure switch judged by IPDM E/R.
DTRL REQ [Off/On]		Displays the status of the daytime running light request signal received from BCM via CAN communication. NOTE: This item is monitored only the vehicle with daytime running light system.
HOOD SW [Off/On]		Displays the status of the hood switch judged by IPDM E/R. NOTE: This item is monitored only the vehicle for Mexico.
THFT HRN REQ [Off/On]		Displays the status of the horn request signal by vehicle security system or panic alarm system received from BCM via CAN communication.
HORN CHIRP [Off/On]		Displays the status of the horn request signal by key fob LOCK operation received from BCM via CAN communication.

ACTIVE TEST

Test item

Test item	Operation	Description
REAR DEFOGGER	Off	OFF
	On	Operates the rear window defogger relay.
FRONT WIPER	Off	OFF
	Lo	Operates the front wiper relay.
	Hi	Operates the front wiper relay and front wiper high relay.

DIAGNOSIS SYSTEM (IPDM E/R)

< SYSTEM DESCRIPTION >

Test item	Operation	Description
MOTOR FAN	1	OFF
	2	Operates the cooling fan relay (LO operation).
	3	Operates the cooling fan relay (MID operation).
	4	Operates the cooling fan relay (HI operation).
EXTERNAL LAMPS	Off	OFF
	TAIL	Operates the tail lamp relay and the daytime running light relay. NOTE: Daytime running light relay is with daytime running light system only.
	Lo	Operates the headlamp low relay.
	Hi	Operates the headlamp low relay and ON/OFF the headlamp high relay at 4 seconds intervals.
	Fog	Operates the front fog lamp relay. NOTE: This item can test only the vehicle with front fog lamp system.
HORN	On	Operates horn relay for 20 ms.

A
B
C
D
E
F
G
H
I
J
K
DEF
M
N
O
P

DEF

REAR WINDOW DEFOGGER SWITCH

< DTC/CIRCUIT DIAGNOSIS >

DTC/CIRCUIT DIAGNOSIS

REAR WINDOW DEFOGGER SWITCH WITH AUTO A/C

WITH AUTO A/C : Component Function Check

INFOID:000000008278359

1. CHECK REAR WINDOW DEFOGGER SWITCH FUNCTION

1. Perform ("REAR DEF SW") in BCM - REAR DEFOGGER "DATA MONITOR" mode by using CONSULT.
2. Operate rear window defogger switch and check Monitor Status on CONSULT screen.

Monitor Item	Condition		Monitor Status
REAR DEF SW	rear window defogger switch	Pressed	On
		Released	Off

Is the inspection result normal?

- YES >> Rear window defogger switch function is OK.
NO >> Refer to [DEF-14, "WITH AUTO A/C : Diagnosis Procedure"](#).

WITH AUTO A/C : Diagnosis Procedure

INFOID:000000008278360

1. CHECK AUTO A/C

Check the operating condition of auto A/C

Does auto A/C operate normally?

- YES >> GO TO 2.
NO >> Perform auto A/C diagnosis. Refer to [HAC-5, "Work Flow"](#).

2. CHECK BCM OUTPUT SIGNAL

1. Turn ignition switch OFF.
2. Disconnect AUTO amp. connector.
3. Check voltage between AUTO amp. harness connector and ground.

(+)		(-)	Waveform (Approx.)
AUTO amp.			
Connector	Terminal	Ground	Battery voltage
M55	22		

Is the inspection result normal?

- YES >> GO TO 4.
NO >> GO TO 3.

3. CHECK REAR WINDOW DEFOGGER SWITCH CIRCUIT

1. Disconnect BCM connector.
2. Check continuity between BCM harness connector and AUTO amp. harness connector.

BCM		AUTO amp.		Continuity
Connector	Terminal	Connector	Terminal	
M65	10	M55	22	Existed

Is the inspection result normal?

- YES >> Replace BCM. Refer to [BCS-65, "Removal and Installation"](#).
NO >> Repair or replace harness.

4. REPLACE AUTO AMP.

1. Turn ignition switch OFF.
2. Replace AUTO amp.
3. Turn ignition switch ON.

REAR WINDOW DEFOGGER SWITCH

< DTC/CIRCUIT DIAGNOSIS >

4. Operate rear window defogger switch and check the operating condition.

Is the inspection result normal?

- YES >> INSPECTION END.
- NO >> GO TO 5.

5.CHECK INTERMITTENT INCIDENT

Refer to [GI-46, "Intermittent Incident"](#).

Is the inspection result normal?

- >> INSPECTION END.

WITH MANUAL A/C

WITH MANUAL A/C : Component Function Check

INFOID:000000008278361

1.CHECK REAR WINDOW DEFOGGER SWITCH FUNCTION

1. Perform ("REAR DEF SW") in BCM - REAR DEFOGGER "DATA MONITOR" mode by using CONSULT.
2. Operate rear window defogger switch and check Monitor Status on CONSULT screen.

Monitor Item	Condition	Monitor Status
REAR DEF SW	rear window defogger switch Pressed	On
	Released	Off

Is the inspection result normal?

- YES >> Rear window defogger switch function is OK.
- NO >> Refer to [DEF-15, "WITH MANUAL A/C : Diagnosis Procedure"](#).

WITH MANUAL A/C : Diagnosis Procedure

INFOID:000000008278362

1.CHECK MANUNAL A/C

Check the operating condition of manual A/C

Does manual A/C operate normally?

- YES >> GO TO 2.
- NO >> Perform manual A/C diagnosis. Refer to [HAC-121, "Work Flow"](#).

2.CHECK BCM OUTPUT SIGNAL

1. Turn ignition switch OFF.
2. Disconnect A/C amp. connector.
3. Check voltage between A/C amp. harness connector and ground.

(+)		(-)	Waveform (Approx.)
A/C amp.			
Connector	Terminal	Ground	Battery voltage
M50	38		

Is the inspection result normal?

- YES >> GO TO 4.
- NO >> GO TO 3.

3.CHECK REAR WINDOW DEFOGGER SWITCH CIRCUIT

1. Disconnect BCM connector.
2. Check continuity between BCM harness connector and A/C amp. harness connector.

BCM		A/C amp.		Continuity
Connector	Terminal	Connector	Terminal	
M65	10	M50	38	Existed

Is the inspection result normal?

- YES >> Replace BCM. Refer to [BCS-65, "Removal and Installation"](#).

A
B
C
D
E
F
G
H
I
J
K
M
N
O
P

DEF

REAR WINDOW DEFOGGER SWITCH

< DTC/CIRCUIT DIAGNOSIS >

NO >> Repair or replace harness.

4. REPLACE A/C AMP.

1. Turn ignition switch OFF.
2. Replace A/C amp.
3. Turn ignition switch ON.
4. Operate rear window defogger switch and check the operating condition.

Is the inspection result normal?

YES >> INSPECTION END.

NO >> GO TO 5.

5. CHECK INTERMITTENT INCIDENT

Refer to [GI-46. "Intermittent Incident"](#).

Is the inspection result normal?

>> INSPECTION END.

REAR WINDOW DEFOGGER RELAY

< DTC/CIRCUIT DIAGNOSIS >

REAR WINDOW DEFOGGER RELAY

Component Function Check

INFOID:000000008278363

1.CHECK REAR WINDOW DEFOGGER RELAY

1. Select "REAR DEFOGGER" in "Active Test" (IPDM E/R) mode with CONSULT.
2. Check rear window defogger relay operation.

Test item		Description	
REAR DEFOGGER	ON	Rear window defogger relay	ON
	OFF		OFF

Is the inspection result normal?

- YES >> Rear window defogger relay is OK.
 NO >> Refer to [DEF-17, "Diagnosis Procedure"](#).

Diagnosis Procedure

INFOID:000000008278364

1.CHECK FUSE

1. Turn ignition switch OFF.
2. Check the following.
 - 15A fuse (No. 55, located in IPDM E/R)
 - 15A fuse (No. 56, located in IPDM E/R)

Is the inspection result normal?

- YES >> GO TO 2.
 NO >> Replace the blown fuse after repairing the affected circuit if a fuse is blown.

2.CHECK IPDM E/R OUTPUT SIGNAL

1. Turn ignition switch ON.
2. Check voltage between IPDM E/R harness connector and ground.

(+)		(-)	Condition	Voltage (V) (Approx.)
IPDM E/R				
Connector	Terminal	Ground	Rear window de-fogger	Battery voltage
E11	12			
		OFF	0	

Is the inspection result normal?

- YES >> GO TO 3.
 NO >> Replace IPDM E/R.

3.CHECK INTERMITTENT INCIDENT

Refer to [GI-46, "Intermittent Incident"](#).

>> INSPECTION END

A
B
C
D
E
F
G
H
I
J
K
L
M
N
O
P

DEF

DOOR MIRROR DEFOGGER RELAY

< DTC/CIRCUIT DIAGNOSIS >

DOOR MIRROR DEFOGGER RELAY

Component Function Check

INFOID:000000008278365

1. CHECK REAR WINDOW DEFOGGER

Check that the heating wire of door mirror defogger is heated when turning the rear window defogger switch ON.

Is the inspection result normal?

- YES >> Door mirror defogger relay is OK.
- NO >> Refer to [DEF-18, "Diagnosis Procedure"](#).

Diagnosis Procedure

INFOID:000000008278366

1. CHECK DOOR MIRROR DEFOGGER RELAY CIRCUIT 1

1. Turn ignition switch ON.
2. Check voltage between door mirror defogger relay harness connector and ground.

(+)		(-)	Condition	Voltage (V) (Approx.)	
Connector	Terminal				
M10	3	Ground	Rear window defogger switch	ON	Battery voltage
				OFF	0

Is the inspection result normal?

- YES >> GO TO 3.
- NO >> GO TO 2.

2. CHECK DOOR MIRROR DEFOGGER RELAY CIRCUIT 2

1. Turn ignition switch OFF.
2. Disconnect door mirror defogger relay and IPDM E/R connector.
3. Check continuity between door mirror defogger relay harness connector and IPDM E/R harness connector.

Door mirror defogger relay		IPDM E/R		Continuity
Connector	Terminal	Connector	Terminal	
M10	3	E11	12	Existed

Is the inspection result normal?

- YES >> GO TO 7.
- NO >> Repair or replace harness.

3. CHECK FUSE

1. Turn ignition switch OFF.
2. Check 10 A fuse (No. 7).

Is the inspection result normal?

- YES >> GO TO 4.
- NO >> Replace the blown fuse after repairing the affected circuit if a fuse is blown.

4. CHECK DOOR MIRROR DEFOGGER RELAY CIRCUIT 2

Check voltage between door mirror defogger relay harness connector and ground.

(+)		(-)	Voltage (V) (Approx.)
Connector	Terminal		
M10	1	Ground	Battery voltage

DOOR MIRROR DEFOGGER RELAY

< DTC/CIRCUIT DIAGNOSIS >

Is the inspection result normal?

- YES >> GO TO 5.
- NO >> Repair or replace harness.

5.CHECK DOOR MIRROR DEFOGGER RELAY GROUND CIRCUIT

1. Turn ignition switch OFF.
2. Disconnect door mirror defogger relay connector.
3. Check continuity between door mirror defogger relay harness connector and ground.

Door mirror defogger relay		Ground	Continuity
Connector	Terminal		
M10	4		Existed

Is the inspection result normal?

- YES >> GO TO 6.
- NO >> Repair or replace harness.

6.CHECK DOOR MIRROR DEFOGGER RELAY

Check door mirror defogger relay.
Refer to [DEF-19, "Component Inspection"](#).

Is the inspection result normal?

- YES >> GO TO 7.
- NO >> Replace door mirror defogger relay.

7.CHECK INTERMITTENT INCIDENT

Check intermittent incident.
Refer to [GI-46, "Intermittent Incident"](#).

>> INSPECTION END

Component Inspection

INFOID:000000008278367

1.CHECK DOOR MIRROR DEFOGGER RELAY

Check continuity between door mirror defogger relay terminals.

Door mirror defogger relay		Condition	Continuity
Terminal			
1	2	Battery voltage direct current supply between terminals 3 and 4	Existed
		Other than above	Does not existed

Is the inspection result normal?

- YES >> Door mirror defogger relay is OK.
- NO >> Replace door mirror defogger relay.

A
B
C
D
E
F
G
H
I
J
K
M
N
O
P

DEF

REAR WINDOW DEFOGGER

< DTC/CIRCUIT DIAGNOSIS >

REAR WINDOW DEFOGGER

Component Function Check

INFOID:000000008278368

1. CHECK REAR WINDOW DEFOGGER

Check that the heating wire of rear window defogger is heated when turning the rear window defogger switch ON.

Is the inspection result normal?

- YES >> Rear window defogger is OK.
- NO >> Refer to [DEF-20, "Diagnosis Procedure"](#).

Diagnosis Procedure

INFOID:000000008278369

1. CHECK REAR WINDOW DEFOGGER POWER SUPPLY CIRCUIT

1. Turn ignition switch OFF.
2. Disconnect rear window defogger connector.
3. Turn ignition switch ON.
4. Check voltage between rear window defogger harness connector and ground.

(+)		(-)	Condition		Voltage (V) (Approx.)
Connector	Terminal				
D160	1	Ground	Rear window defogger switch	ON	Battery voltage
				OFF	0

Is the inspection result normal?

- YES >> GO TO 2.
- NO >> GO TO 4.

2. CHECK REAR WINDOW DEFOGGER GROUND CIRCUIT

1. Turn ignition switch OFF.
2. Check continuity between rear window defogger harness connector and ground.

Rear window defogger		Ground	Continuity
Connector	Terminal		
D185	2		Existed

Is the inspection result normal?

- YES >> GO TO 3.
- NO >> Repair or replace harness.

3. CHECK FILAMENT

Check filament.

Refer to [DEF-39, "Inspection and Repair"](#).

Is the inspection result normal?

- YES >> GO TO 5.
- NO >> Repair filament.

4. CHECK REAR WINDOW DEFOGGER POWER SUPPLY CIRCUIT

1. Turn ignition switch OFF.
2. Disconnect IPDM E/R and rear window defogger connectors.
3. Check continuity between IPDM E/R harness connector and rear window defogger harness connector.

REAR WINDOW DEFOGGER

< DTC/CIRCUIT DIAGNOSIS >

IPDM E/R		Rear window defogger		Continuity
Connector	Terminal	Connector	Terminal	
E11	12	D160	1	Existed

Is the inspection result normal?

YES >> GO TO 5.

NO >> Repair or replace harness.

5.CHECK INTERMITTENT INCIDENT

Refer to [GI-46. "Intermittent Incident"](#)

>> INSPECTION END

A
B
C
D
E
F
G
H
I
J
K
DEF
M
N
O
P

DEF

DRIVER SIDE DOOR MIRROR DEFOGGER

< DTC/CIRCUIT DIAGNOSIS >

DRIVER SIDE DOOR MIRROR DEFOGGER

Component Function Check

INFOID:000000008278370

1. CHECK DRIVER SIDE DOOR MIRROR DEFOGGER

Check that heating wire of driver side door mirror defogger is heated when turning the rear window defogger switch ON.

Is the inspection result normal?

- YES >> Driver side door mirror defogger is OK.
- NO >> Refer to [DEF-22, "Diagnosis Procedure"](#).

Diagnosis Procedure

INFOID:000000008278371

1. CHECK DOOR MIRROR DEFOGGER POWER SUPPLY CIRCUIT

1. Turn ignition switch OFF.
2. Disconnect door mirror (driver side) connector.
3. Turn ignition switch ON.
4. Check voltage between door mirror (driver side) harness connector and ground.

Without around view monitor

(+)		(-)	Condition	Voltage (V) (Approx.)
Door mirror (driver side) Connector	Terminal			
D3	1	Ground	Rear window defogger switch	ON Battery voltage
			OFF 0	

With around view monitor

(+)		(-)	Condition	Voltage (V) (Approx.)
Door mirror (driver side) Connector	Terminal			
D35	6	Ground	Rear window defogger switch	ON Battery voltage
			OFF 0	

Is the inspection result normal?

- YES >> GO TO 2.
- NO >> GO TO 3.

2. CHECK DOOR MIRROR DEFOGGER GROUND CIRCUIT

1. Turn ignition switch OFF.
2. Check continuity between door mirror (driver side) harness connector and ground.

Without around view monitor

Door mirror (driver side)		Ground	Continuity
Connector	Terminal		
D3	5		Existed

With around view monitor

Door mirror (driver side)		Ground	Continuity
Connector	Terminal		
D35	12		Existed

Is the inspection result normal?

- YES >> Replace glass mirror (driver side).
- NO >> Repair or replace harness.

3. CHECK DOOR MIRROR CIRCUIT

1. Turn ignition switch OFF.
2. Disconnect door mirror defogger relay connector and door mirror (driver side) connector.

DRIVER SIDE DOOR MIRROR DEFOGGER

< DTC/CIRCUIT DIAGNOSIS >

3. Check continuity between door mirror (driver side) harness connector and door mirror defogger relay harness connector.

Without around view monitor

Door mirror (driver side)		Door mirror defogger relay		Continuity
Connector	Terminal	Connector	Terminal	
D3	1	M10	2	Existed

With around view monitor

Door mirror (driver side)		Door mirror defogger relay		Continuity
Connector	Terminal	Connector	Terminal	
D35	6	M10	2	Existed

Is the inspection result normal?

YES >> GO TO 4.

NO >> Repair or replace harness.

4. CHECK INTERMITTENT

Refer to [GI-46, "Intermittent Incident"](#).

>> INSPECTION END

A
B
C
D
E
F
G
H
I
J
K
M
N
O
P

DEF

PASSENGER SIDE DOOR MIRROR DEFOGGER

< DTC/CIRCUIT DIAGNOSIS >

PASSENGER SIDE DOOR MIRROR DEFOGGER

Component Function Check

INFOID:000000008278372

1. CHECK PASSENGER SIDE DOOR MIRROR DEFOGGER

Check that heating wire of passenger side door mirror defogger is heated when turning the rear window defogger switch ON.

Is the inspection result normal?

- YES >> Passenger side door mirror defogger is OK.
- NO >> Refer to [DEF-24, "Diagnosis Procedure"](#).

Diagnosis Procedure

INFOID:000000008278373

1. CHECK DOOR MIRROR DEFOGGER POWER SUPPLY CIRCUIT

1. Turn ignition switch OFF.
2. Disconnect door mirror (passenger side) connector.
3. Turn ignition switch ON.
4. Check voltage between door mirror (passenger side) harness connector and ground.

Without around view monitor

(+)		(-)	Condition	Voltage (V) (Approx.)	
Door mirror (passenger side) Connector	Terminal				
D43	1	Ground	Rear window defogger switch	ON	Battery voltage
			OFF	0	

With around view monitor

(+)		(-)	Condition	Voltage (V) (Approx.)	
Door mirror (passenger side) Connector	Terminal				
D34	6	Ground	Rear window defogger switch	ON	Battery voltage
			OFF	0	

Is the inspection result normal?

- YES >> GO TO 2.
- NO >> GO TO 3.

2. CHECK DOOR MIRROR DEFOGGER GROUND CIRCUIT

1. Turn ignition switch OFF.
2. Check continuity between door mirror (passenger side) harness connector and ground.

Without around view monitor

Door mirror (passenger side)		Ground	Continuity
Connector	Terminal		
D43	5		Existed

With around view monitor

Door mirror (passenger side)		Ground	Continuity
Connector	Terminal		
D34	12		Existed

Is the inspection result normal?

- YES >> Replace glass mirror (passenger side).
- NO >> Repair or replace harness.

3. CHECK DOOR MIRROR CIRCUIT

1. Turn ignition switch OFF.
2. Disconnect door mirror defogger relay connector and door mirror (passenger side) connector.

PASSENGER SIDE DOOR MIRROR DEFOGGER

< DTC/CIRCUIT DIAGNOSIS >

3. Check continuity between door mirror (passenger side) harness connector and door mirror defogger relay harness connector.

Without around view monitor

Door mirror (passenger side)		Door mirror defogger relay		Continuity
Connector	Terminal	Connector	Terminal	
D43	1	M10	2	Existed

With around view monitor

Door mirror (passenger side)		Door mirror defogger relay		Continuity
Connector	Terminal	Connector	Terminal	
D34	6	M10	2	Existed

Is the inspection result normal?

YES >> GO TO 4.

NO >> Repair or replace harness.

4.CHECK INTERMITTENT

Refer to [GI-46, "Intermittent Incident"](#).

>> INSPECTION END

A
B
C
D
E
F
G
H
I
J
K
DEF
M
N
O
P

REAR WINDOW DEFOGGER FEEDBACK SIGNAL

< DTC/CIRCUIT DIAGNOSIS >

REAR WINDOW DEFOGGER FEEDBACK SIGNAL WITH AUTO A/C

WITH AUTO A/C : Component Function Check

INFOID:000000008278374

1. CHECK REAR WINDOW DEFOGGER ON SIGNAL

Check that the indicator lamps of rear window defogger switch are illuminated when turning the rear window defogger switch ON.

Is the inspection result normal?

- OK >> Rear window defogger feedback signal is OK.
- NG >> Refer to [DEF-26, "WITH AUTO A/C : Diagnosis Procedure"](#).

WITH AUTO A/C : Diagnosis Procedure

INFOID:000000008278375

1. CHECK FUSE

1. Turn ignition switch OFF.
2. Check the following.
 - 10A fuse (No. 5)

Is the inspection result normal?

- YES >> GO TO 2.
- NO >> Replace the blown fuse after repairing the affected circuit if a fuse is blown.

2. CHECK REAR WINDOW DEFOGGER FEEDBACK SIGNAL

1. Turn ignition switch ON.
2. Check voltage between AUTO amp. connector and ground.

(+)		(-)	Condition		Voltage (V) (Approx.)
AUTO amp.					
Connector	Terminal				
M55	23	Ground	Rear window defogger switch	ON	Battery voltage
				OFF	0

Is the inspection result normal?

- YES >> Replace AUTO amp. Refer to [HAC-207, "Removal and Installation"](#).
- NO >> GO TO 3.

3. CHECK REAR WINDOW DEFOGGER INDICATOR LAMPS CIRCUIT

1. Turn ignition switch OFF.
2. Disconnect IPDM E/R connector and AUTO amp. connector.
3. Check continuity between IPDM E/R harness connector and AUTO amp. harness connector.

IPDM E/R		AUTO amp.		Continuity
Connector	Terminal	Connector	Terminal	
E11	12	M55	23	Existed

Is the inspection result normal?

- YES >> GO TO 4.
- NO >> Repair or replace harness.

4. CHECK INTERMITTENT INCIDENT

Refer to [GI-46, "Intermittent Incident"](#).

>> INSPECTION END
WITH MANUAL A/C

REAR WINDOW DEFOGGER FEEDBACK SIGNAL

< DTC/CIRCUIT DIAGNOSIS >

WITH MANUAL A/C : Component Function Check

INFOID:000000008278376

1.CHECK REAR WINDOW DEFOGGER ON SIGNAL

Check that the indicator lamps of rear window defogger switch are illuminated when turning the rear window defogger switch ON.

Is the inspection result normal?

- OK >> Rear window defogger feedback signal is OK.
- NG >> Refer to [DEF-27, "WITH MANUAL A/C : Diagnosis Procedure"](#).

WITH MANUAL A/C : Diagnosis Procedure

INFOID:000000008278377

1.CHECK FUSE

1. Turn ignition switch OFF.
2. Check the following.
 - 10A fuse (No. 5)

Is the inspection result normal?

- YES >> GO TO 2.
- NO >> Replace the blown fuse after repairing the affected circuit if a fuse is blown.

2.CHECK REAR WINDOW DEFOGGER FEEDBACK SIGNAL

1. Turn ignition switch ON.
2. Check voltage between A/C amp. connector and ground.

(+)		(-)	Condition	Voltage (V) (Approx.)
A/C amp.				
Connector	Terminal			
M50	20	Ground	Rear window defogger switch	Battery voltage
				0

Is the inspection result normal?

- YES >> Replace A/C amp.
- NO >> GO TO 3.

3.CHECK REAR WINDOW DEFOGGER INDICATOR LAMPS CIRCUIT

1. Turn ignition switch OFF.
2. Disconnect IPDM E/R connector and A/C amp. connector.
3. Check continuity between IPDM E/R harness connector and A/C amp. harness connector.

IPDM E/R		A/C amp.		Continuity
Connector	Terminal	Connector	Terminal	
E11	12	M50	20	Existed

Is the inspection result normal?

- YES >> GO TO 4.
- NO >> Repair or replace harness.

4.CHECK INTERMITTENT INCIDENT

Refer to [GI-46, "Intermittent Incident"](#).

>> INSPECTION END

A
B
C
D
E
F
G
H
I
J
K
M
N
O
P

DEF

REAR WINDOW DEFOGGER SYSTEM

< DTC/CIRCUIT DIAGNOSIS >

REAR WINDOW DEFOGGER SYSTEM

Wiring Diagram - REAR WINDOW DEFOGGER SYSTEM -

INFOID:000000008278378

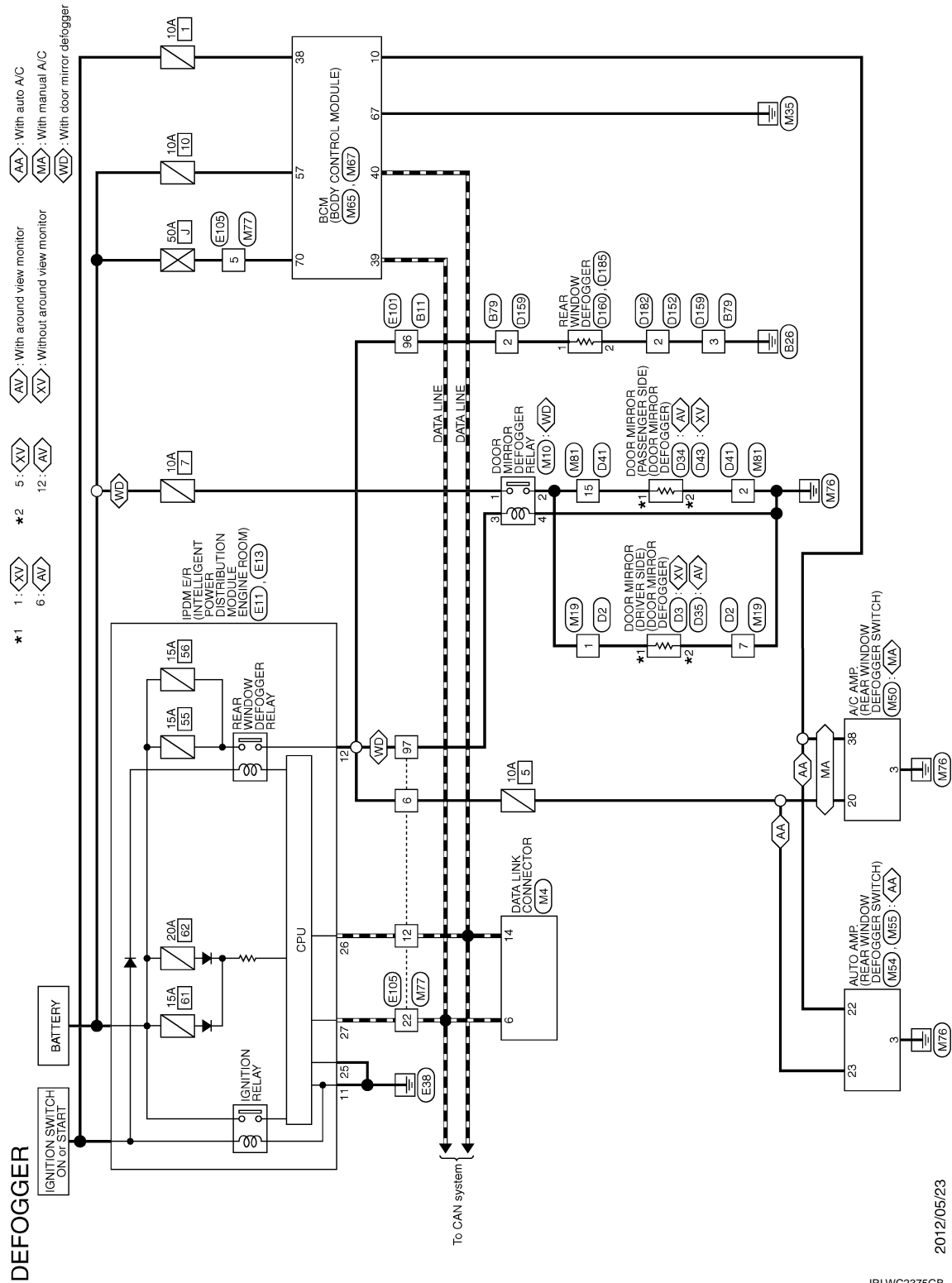

BCM, IPDM E/R

< ECU DIAGNOSIS INFORMATION >

ECU DIAGNOSIS INFORMATION

BCM, IPDM E/R

List of ECU Reference

INFOID:000000008278379

ECU	Reference
BCM	BCS-42, "Reference Value"
	BCS-60, "Fail-safe"
	BCS-61, "DTC Inspection Priority Chart"
	BCS-61, "DTC Index"
IPDM E/R	PCS-16, "Reference Value"
	PCS-23, "Fail-safe"
	PCS-25, "DTC Index"

A
B
C
D
E
F
G
H
I
J
K
DEF
M
N
O
P

DEF

REAR WINDOW DEFOGGER DOES NOT OPERATE

< SYMPTOM DIAGNOSIS >

SYMPTOM DIAGNOSIS

REAR WINDOW DEFOGGER DOES NOT OPERATE

Description

INFOID:000000008278380

For models without door mirror defogger.

Diagnosis Procedure

INFOID:000000008278381

1. CHECK REAR WINDOW DEFOGGER SWITCH

Check rear window defogger switch.

Refer to [DEF-14, "WITH AUTO A/C : Component Function Check"](#) (For models with auto A/C) or [DEF-15, "WITH MANUAL A/C : Component Function Check"](#) (For models with manual A/C).

Is the inspection result normal?

YES >> GO TO 2.

NO >> Repair or replace the malfunctioning parts.

2. CHECK REAR WINDOW DEFOGGER RELAY

Check rear window defogger relay.

Refer to [DEF-17, "Component Function Check"](#).

Is the inspection result normal?

YES >> GO TO 3.

NO >> Repair or replace the malfunctioning parts.

3. CHECK REAR WINDOW DEFOGGER

Check rear window defogger.

Refer to [DEF-20, "Component Function Check"](#).

Is the inspection result normal?

YES >> GO TO 4.

NO >> Repair or replace the malfunctioning parts.

4. CONFIRM THE OPERATION

Confirm the operation again.

Is the result normal?

YES >> Check intermittent incident. Refer to [GI-46, "Intermittent Incident"](#).

NO >> GO TO 1.

REAR WINDOW DEFOGGER AND DOOR MIRROR DEFOGGER DO NOT OPERATE

< SYMPTOM DIAGNOSIS >

REAR WINDOW DEFOGGER AND DOOR MIRROR DEFOGGER DO NOT OPERATE

Description

INFOID:000000008278382

For models with door mirror defogger.

Diagnosis Procedure

INFOID:000000008278383

1. CHECK REAR WINDOW DEFOGGER SWITCH

Check rear window defogger switch.

Refer to [DEF-14. "WITH AUTO A/C : Component Function Check"](#) (For models with auto A/C) or [DEF-15. "WITH MANUAL A/C : Component Function Check"](#) (For models with manual A/C).

Is the inspection result normal?

YES >> GO TO 2.

NO >> Repair or replace the malfunctioning parts.

2. CHECK REAR WINDOW DEFOGGER RELAY

Check rear window defogger relay.

Refer to [DEF-17. "Component Function Check"](#).

Is the inspection result normal?

YES >> GO TO 3.

NO >> Repair or replace the malfunctioning parts.

3. CHECK DOOR MIRROR DEFOGGER RELAY

Check door mirror defogger relay.

Refer to [DEF-18. "Component Function Check"](#).

Is the inspection result normal?

YES >> GO TO 4.

NO >> Repair or replace the malfunctioning parts.

4. CONFIRM THE OPERATION

Confirm the operation again.

Is the result normal?

YES >> Check intermittent incident. Refer to [GI-46. "Intermittent Incident"](#).

NO >> GO TO 1.

A
B
C
D
E
F
G
H
I
J
K
DEF
M
N
O
P

REAR WINDOW DEFOGGER DOES NOT OPERATE BUT BOTH DOOR MIRROR DEFOGGER OPERATE

< SYMPTOM DIAGNOSIS >

REAR WINDOW DEFOGGER DOES NOT OPERATE BUT BOTH DOOR MIRROR DEFOGGER OPERATE

Description

INFOID:000000008278384

For models with door mirror defogger.

Diagnosis Procedure

INFOID:000000008278385

1. CHECK REAR WINDOW DEFOGGER

Check rear window defogger.

Refer to [DEF-20. "Component Function Check"](#).

Is the inspection result normal?

YES >> GO TO 2.

NO >> Repair or replace the malfunctioning parts.

2. CONFIRM THE OPERATION

Confirm the operation again.

Is the result normal?

YES >> Check intermittent incident. Refer to [GI-46. "Intermittent Incident"](#).

NO >> GO TO 1.

DOOR MIRROR DEFOGGER DOES NOT OPERATE

< SYMPTOM DIAGNOSIS >

DOOR MIRROR DEFOGGER DOES NOT OPERATE BOTH SIDE

BOTH SIDE : Description

INFOID:000000008278386

Both side door mirror defoggers do not operate.

BOTH SIDE : Diagnosis Procedure

INFOID:000000008278387

1.CHECK DOOR MIRROR DEFOGGER RELAY

Check door mirror defogger relay.
Refer to [DEF-18, "Component Function Check"](#).

Is the inspection result normal?

- YES >> GO TO 2.
- NO >> Repair or replace the malfunctioning parts.

2.CONFIRM THE OPERATION

Confirm the operation again.

Is the result normal?

- YES >> Check intermittent incident. Refer to [GI-46, "Intermittent Incident"](#).
- NO >> GO TO 1.

DRIVER SIDE

DRIVER SIDE : Description

INFOID:000000008278388

Driver side door mirror defogger does not operate but passenger side door mirror defogger operates.

DRIVER SIDE : Diagnosis Procedure

INFOID:000000008278389

1.CHECK DRIVER SIDE DOOR MIRROR DEFOGGER

Check driver side door mirror defogger.
Refer to [DEF-22, "Component Function Check"](#).

Is the inspection result normal?

- YES >> GO TO 2.
- NO >> Repair or replace the malfunctioning parts.

2.CONFIRM THE OPERATION

Confirm the operation again.

Is the result normal?

- YES >> Check intermittent incident. Refer to [GI-46, "Intermittent Incident"](#).
- NO >> GO TO 1.

PASSENGER SIDE

PASSENGER SIDE : Description

INFOID:000000008278390

Passenger side door mirror defogger does not operate but driver side door mirror defogger operates.

PASSENGER SIDE : Diagnosis Procedure

INFOID:000000008278391

1.CHECK PASSENGER SIDE DOOR MIRROR DEFOGGER.

Check passenger side door mirror defogger.
Refer to [DEF-24, "Component Function Check"](#).

Is the inspection result normal?

- YES >> GO TO 2.
- NO >> Repair or replace the malfunctioning parts.

2.CONFIRM THE OPERATION

A
B
C
D
E
F
G
H
I
J
K
DEF
M
N
O
P

DOOR MIRROR DEFOGGER DOES NOT OPERATE

< SYMPTOM DIAGNOSIS >

Confirm the operation again.

Is the result normal?

YES >> Check intermittent incident. Refer to [GI-46. "Intermittent Incident"](#).

NO >> GO TO 1.

REAR WINDOW DEFOGGER INDICATOR DOES NOT ILLUMINATE

< SYMPTOM DIAGNOSIS >

REAR WINDOW DEFOGGER INDICATOR DOES NOT ILLUMINATE

Diagnosis Procedure

INFOID:000000008278392

1. CHECK REAR WINDOW DEFOGGER INDICATOR

Check rear window defogger feedback signal.

Refer to [DEF-26, "WITH AUTO A/C : Component Function Check"](#) (For models with auto A/C) or [DEF-27, "WITH MANUAL A/C : Component Function Check"](#) (For models with manual A/C).

Is the inspection result normal?

YES >> GO TO 2.

NO >> Repair or replace the malfunctioning parts.

2. CONFIRM THE OPERATION

Confirm the operation again.

Is the result normal?

YES >> Check intermittent incident. Refer to [GI-46, "Intermittent Incident"](#).

NO >> GO TO 1.

A
B
C
D
E
F
G
H
I
J
K
DEF
M
N
O
P

PRECAUTIONS

< PRECAUTION >

PRECAUTION

PRECAUTIONS

FOR USA AND CANADA

FOR USA AND CANADA : Precaution for Supplemental Restraint System (SRS) "AIR BAG" and "SEAT BELT PRE-TENSIONER"

INFOID:000000008278393

The Supplemental Restraint System such as "AIR BAG" and "SEAT BELT PRE-TENSIONER", used along with a front seat belt, helps to reduce the risk or severity of injury to the driver and front passenger for certain types of collision. This system includes seat belt switch inputs and dual stage front air bag modules. The SRS system uses the seat belt switches to determine the front air bag deployment, and may only deploy one front air bag, depending on the severity of a collision and whether the front occupants are belted or unbelted. Information necessary to service the system safely is included in the "SRS AIR BAG" and "SEAT BELT" of this Service Manual.

WARNING:

Always observe the following items for preventing accidental activation.

- To avoid rendering the SRS inoperative, which could increase the risk of personal injury or death in the event of a collision that would result in air bag inflation, all maintenance must be performed by an authorized NISSAN/INFINITI dealer.
- Improper maintenance, including incorrect removal and installation of the SRS, can lead to personal injury caused by unintentional activation of the system. For removal of Spiral Cable and Air Bag Module, see "SRS AIR BAG".
- Never use electrical test equipment on any circuit related to the SRS unless instructed to in this Service Manual. SRS wiring harnesses can be identified by yellow and/or orange harnesses or harness connectors.

PRECAUTIONS WHEN USING POWER TOOLS (AIR OR ELECTRIC) AND HAMMERS

WARNING:

Always observe the following items for preventing accidental activation.

- When working near the Air Bag Diagnosis Sensor Unit or other Air Bag System sensors with the ignition ON or engine running, never use air or electric power tools or strike near the sensor(s) with a hammer. Heavy vibration could activate the sensor(s) and deploy the air bag(s), possibly causing serious injury.
- When using air or electric power tools or hammers, always switch the ignition OFF, disconnect the battery, and wait at least 3 minutes before performing any service.

FOR USA AND CANADA : Precaution for Procedure without Cowl Top Cover

INFOID:000000008278394

When performing the procedure after removing cowl top cover, cover the lower end of windshield with urethane, etc to prevent damage to windshield.

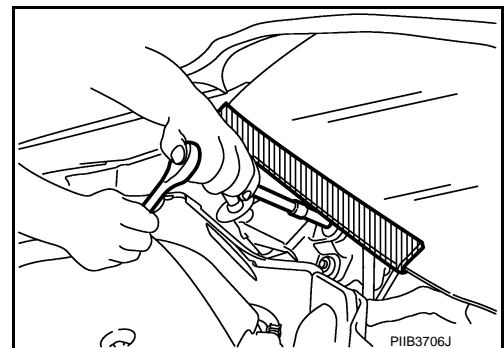

FOR USA AND CANADA : Precautions For Xenon Headlamp Service

INFOID:000000008278395

WARNING:

Comply with the following warnings to prevent any serious accident.

- Disconnect the battery cable (negative terminal) or the power supply fuse before installing, removing, or touching the xenon headlamp (bulb included). The xenon headlamp contains high-voltage generated parts.
- Never work with wet hands.

PRECAUTIONS

< PRECAUTION >

- Check the xenon headlamp ON-OFF status after assembling it to the vehicle. Never turn the xenon headlamp ON in other conditions. Connect the power supply to the vehicle-side connector. (Turning it ON outside the lamp case may cause fire or visual impairments.)
- Never touch the bulb glass immediately after turning it OFF. It is extremely hot.

CAUTION:

Comply with the following cautions to prevent any error and malfunction.

- Install the xenon bulb securely. (Insufficient bulb socket installation may melt the bulb, the connector, the housing, etc. by high-voltage leakage or corona discharge.)
- Never perform HID circuit inspection with a tester.
- Never touch the xenon bulb glass with hands. Never put oil and grease on it.
- Dispose of the used xenon bulb after packing it in thick vinyl without breaking it.
- Never wipe out dirt and contamination with organic solvent (thinner, gasoline, etc.).

FOR MEXICO

FOR MEXICO : Precaution for Supplemental Restraint System (SRS) "AIR BAG" and "SEAT BELT PRE-TENSIONER"

INFOID:000000008278396

The Supplemental Restraint System such as "AIR BAG" and "SEAT BELT PRE-TENSIONER", used along with a front seat belt, helps to reduce the risk or severity of injury to the driver and front passenger for certain types of collision. Information necessary to service the system safely is included in the "SRS AIR BAG" and "SEAT BELT" of this Service Manual.

WARNING:

Always observe the following items for preventing accidental activation.

- To avoid rendering the SRS inoperative, which could increase the risk of personal injury or death in the event of a collision that would result in air bag inflation, all maintenance must be performed by an authorized NISSAN/INFINITI dealer.
- Improper maintenance, including incorrect removal and installation of the SRS, can lead to personal injury caused by unintentional activation of the system. For removal of Spiral Cable and Air Bag Module, see "SRS AIR BAG".
- Never use electrical test equipment on any circuit related to the SRS unless instructed to in this Service Manual. SRS wiring harnesses can be identified by yellow and/or orange harnesses or harness connectors.

PRECAUTIONS WHEN USING POWER TOOLS (AIR OR ELECTRIC) AND HAMMERS

WARNING:

Always observe the following items for preventing accidental activation.

- When working near the Air Bag Diagnosis Sensor Unit or other Air Bag System sensors with the ignition ON or engine running, never use air or electric power tools or strike near the sensor(s) with a hammer. Heavy vibration could activate the sensor(s) and deploy the air bag(s), possibly causing serious injury.
- When using air or electric power tools or hammers, always switch the ignition OFF, disconnect the battery, and wait at least 3 minutes before performing any service.

FOR MEXICO : Precaution for Procedure without Cowl Top Cover

INFOID:000000008278397

When performing the procedure after removing cowl top cover, cover the lower end of windshield with urethane, etc to prevent damage to windshield.

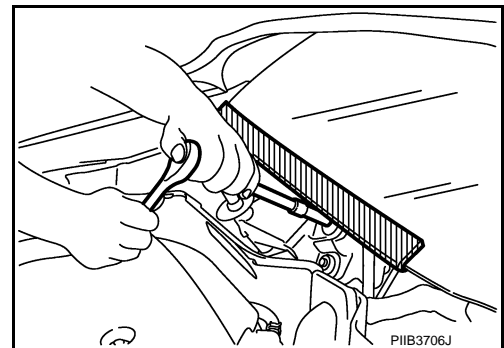

FOR MEXICO : Precautions For Xenon Headlamp Service

INFOID:000000008278398

WARNING:

PRECAUTIONS

< PRECAUTION >

Comply with the following warnings to prevent any serious accident.

- Disconnect the battery cable (negative terminal) or the power supply fuse before installing, removing, or touching the xenon headlamp (bulb included). The xenon headlamp contains high-voltage generated parts.
- Never work with wet hands.
- Check the xenon headlamp ON-OFF status after assembling it to the vehicle. Never turn the xenon headlamp ON in other conditions. Connect the power supply to the vehicle-side connector. (Turning it ON outside the lamp case may cause fire or visual impairments.)
- Never touch the bulb glass immediately after turning it OFF. It is extremely hot.

CAUTION:

Comply with the following cautions to prevent any error and malfunction.

- Install the xenon bulb securely. (Insufficient bulb socket installation may melt the bulb, the connector, the housing, etc. by high-voltage leakage or corona discharge.)
- Never perform HID circuit inspection with a tester.
- Never touch the xenon bulb glass with hands. Never put oil and grease on it.
- Dispose of the used xenon bulb after packing it in thick vinyl without breaking it.
- Never wipe out dirt and contamination with organic solvent (thinner, gasoline, etc.).

FILAMENT

< REMOVAL AND INSTALLATION >

REMOVAL AND INSTALLATION

FILAMENT

Inspection and Repair

INFOID:000000008278399

INSPECTION

1. When measuring voltage, wrap tin foil around the top of the negative probe. Then press the foil against the wire with your finger.

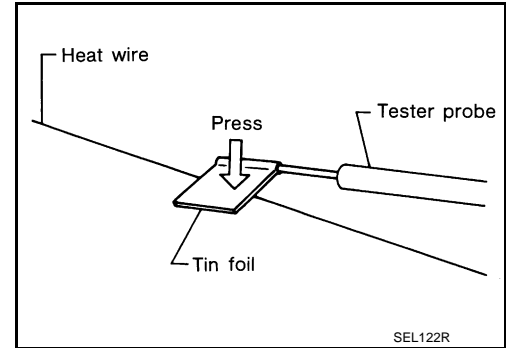

2. Attach probe circuit tester (in Volt range) to middle portion of each filament.

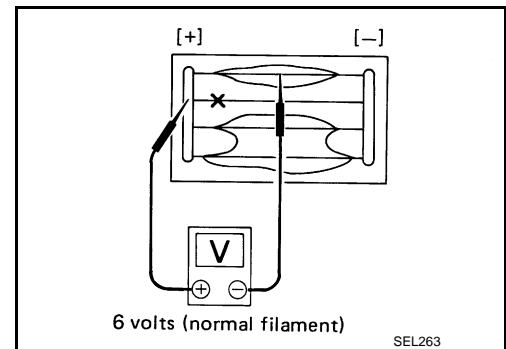

3. If a filament is burned out, circuit tester registers 0 or battery voltage.
4. To locate burned out point, move probe to left and right along filament. Test needle will swing abruptly when probe passes the point.

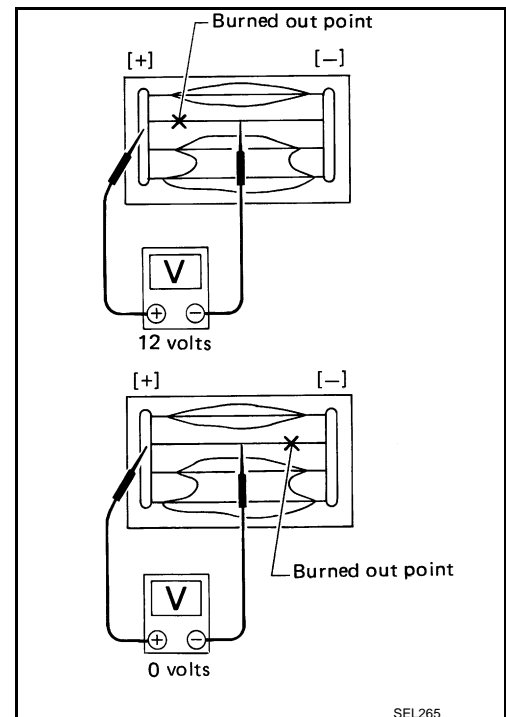

REPAIR

REPAIR EQUIPMENT

- Conductive silver composition (Dupont No. 4817 or equivalent)

A
B
C
D
E
F
G
H
I
J
K
DEF
M
N
O
P

FILAMENT

< REMOVAL AND INSTALLATION >

- Ruler 30 cm (11.8 in) long
- Drawing pen
- Heat gun
- Alcohol
- Cloth

REPAIRING PROCEDURE

1. Wipe broken heat wire and its surrounding area clean with a cloth dampened in alcohol.
2. Apply a small amount of conductive silver composition to tip of drawing pen. Shake silver composition container before use.
3. Place ruler on glass along broken line. Deposit conductive silver composition on break with drawing pen. Slightly overlap existing heat wire on both sides [preferably 5 mm (0.20 in)] of the break.

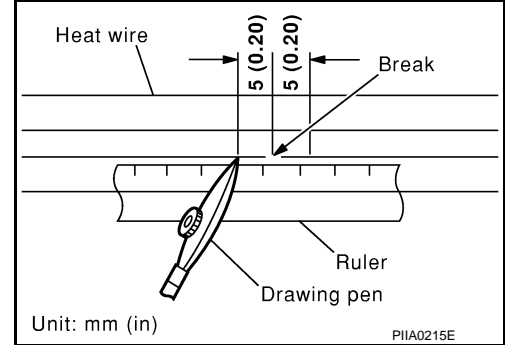

4. After repair has been completed, check repaired wire for continuity. This check should be conducted 10 minutes after silver composition is deposited. Do not touch repaired area while test is being conducted.

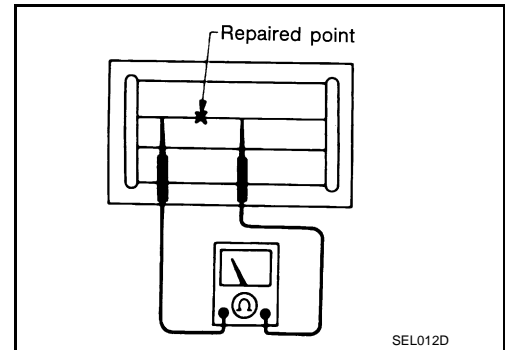

5. Apply a constant stream of hot air directly to the repaired area for approximately 20 minutes with a heat gun. A minimum distance of 3 cm (1.2 in) should be kept between repaired area and hot air outlet. If a heat gun is not available, let the repaired area dry for 24 hours.

