

SECTION **FSU**
FRONT SUSPENSION

A
B
C
D

FSU

CONTENTS

| | | | | |
|---|---|--|----|---|
| SYMPTOM DIAGNOSIS | 2 | WHEEL ALIGNMENT | 7 | F |
| NOISE, VIBRATION AND HARSHNESS (NVH) TROUBLESHOOTING | 2 | Inspection | 7 | |
| NVH Troubleshooting Chart | 2 | Adjustment | 7 | |
| PRECAUTION | 3 | REMOVAL AND INSTALLATION | 9 | G |
| PRECAUTIONS | 3 | FRONT COIL SPRING AND STRUT | 9 | H |
| FOR USA AND CANADA | 3 | Exploded View | 9 | |
| FOR USA AND CANADA : Precaution for Supplemental Restraint System (SRS) "AIR BAG" and "SEAT BELT PRE-TENSIONER" | 3 | Removal and Installation | 10 | |
| FOR USA AND CANADA : Precaution for Procedure without Cowl Top Cover | 3 | Disassembly and Assembly | 10 | |
| FOR USA AND CANADA : Precautions for Suspension | 3 | Inspection | 11 | I |
| FOR MEXICO | 4 | Disposal | 12 | |
| FOR MEXICO : Precaution for Supplemental Restraint System (SRS) "AIR BAG" and "SEAT BELT PRE-TENSIONER" | 4 | TRANSVERSE LINK | 13 | J |
| FOR MEXICO : Precaution for Procedure without Cowl Top Cover | 4 | Exploded View | 13 | |
| FOR MEXICO : Precautions for Suspension | 4 | Removal and Installation | 14 | |
| PREPARATION | 5 | Inspection | 14 | K |
| PREPARATION | 5 | FRONT STABILIZER | 16 | L |
| Special Service Tool | 5 | Exploded View | 16 | |
| Commercial Service Tool | 5 | Removal and Installation | 17 | |
| PERIODIC MAINTENANCE | 6 | Inspection | 17 | |
| FRONT SUSPENSION ASSEMBLY | 6 | UNIT REMOVAL AND INSTALLATION | 18 | M |
| Inspection | 6 | FRONT SUSPENSION MEMBER | 18 | N |
| | | Exploded View | 18 | |
| | | Removal and Installation | 19 | |
| | | Inspection | 19 | |
| | | SERVICE DATA AND SPECIFICATIONS (SDS) | 20 | O |
| | | SERVICE DATA AND SPECIFICATIONS (SDS) | 20 | P |
| | | Wheel Alignment | 20 | |
| | | Ball Joint | 20 | |
| | | Wheelarch Height | 20 | |

NOISE, VIBRATION AND HARSHNESS (NVH) TROUBLESHOOTING

< SYMPTOM DIAGNOSIS >

SYMPTOM DIAGNOSIS

NOISE, VIBRATION AND HARSHNESS (NVH) TROUBLESHOOTING

NVH Troubleshooting Chart

INFOID:000000008280191

Use chart below to find the cause of the symptom. If necessary, repair or replace these parts.

| Symptom | | Possible cause and SUSPECTED PARTS | | | | | | | | | | | | | | | | | Reference |
|------------------|-------------------------------|------------------------------------|--|-----------------------------------|--------------------|----------------|----------------------|---------------------------|------------------------|-----------------------|--------------------|---------------------------------|------|------------|-------------|-------|----------|-------------------------------|-----------|
| | | Improper installation, looseness | Shock absorber deformation, damage or deflection | Bushing or mounting deterioration | Parts interference | Spring fatigue | Suspension looseness | Incorrect wheel alignment | Stabilizer bar fatigue | PROPELLER SHAFT (AWD) | DIFFERENTIAL (AWD) | FRONT AXLE AND FRONT SUSPENSION | TIRE | ROAD WHEEL | DRIVE SHAFT | BRAKE | STEERING | | |
| FRONT SUSPENSION | Noise | x | x | x | x | x | x | | | x | x | x | x | x | x | x | x | FSU-9, FSU-13, FSU-16, FSU-18 | |
| | Shake | x | x | x | x | | x | | | x | | x | x | x | x | | | FSU-11 | |
| | Vibration | x | x | x | x | x | | | | x | | x | x | | x | | | — | |
| | Shimmy | x | x | x | x | | | x | | | | x | x | x | | x | | — | |
| | Judder | x | x | x | | | | | | | | x | x | x | | x | | FSU-11 | |
| | Poor quality ride or handling | x | x | x | x | x | | x | x | | | x | x | x | | | | FSU-9, FSU-13, FSU-16, FSU-18 | |
| | | | | | | | | | | | | | | | | | | FSU-20 | |
| | | | | | | | | | | | | | | | | | | FSU-17 | |
| | | | | | | | | | | | | | | | | | | NVH in DLN section | |
| | | | | | | | | | | | | | | | | | | NVH in DLN section | |
| | | | | | | | | | | | | | | | | | | NVH in FAX and FSU sections | |
| | | | | | | | | | | | | | | | | | | NVH in WT section | |
| | | | | | | | | | | | | | | | | | | NVH in WT section | |
| | | | | | | | | | | | | | | | | | | NVH in FAX section | |
| | | | | | | | | | | | | | | | | | | NVH in BR section | |
| | | | | | | | | | | | | | | | | | | NVH in ST section | |

x: Applicable

PRECAUTIONS

< PRECAUTION >

PRECAUTION

PRECAUTIONS FOR USA AND CANADA

FOR USA AND CANADA : Precaution for Supplemental Restraint System (SRS) "AIR BAG" and "SEAT BELT PRE-TENSIONER"

INFOID:000000008280192

The Supplemental Restraint System such as "AIR BAG" and "SEAT BELT PRE-TENSIONER", used along with a front seat belt, helps to reduce the risk or severity of injury to the driver and front passenger for certain types of collision. This system includes seat belt switch inputs and dual stage front air bag modules. The SRS system uses the seat belt switches to determine the front air bag deployment, and may only deploy one front air bag, depending on the severity of a collision and whether the front occupants are belted or unbelted. Information necessary to service the system safely is included in the "SRS AIR BAG" and "SEAT BELT" of this Service Manual.

WARNING:

Always observe the following items for preventing accidental activation.

- To avoid rendering the SRS inoperative, which could increase the risk of personal injury or death in the event of a collision that would result in air bag inflation, all maintenance must be performed by an authorized NISSAN/INFINITI dealer.
- Improper maintenance, including incorrect removal and installation of the SRS, can lead to personal injury caused by unintentional activation of the system. For removal of Spiral Cable and Air Bag Module, see "SRS AIR BAG".
- Never use electrical test equipment on any circuit related to the SRS unless instructed to in this Service Manual. SRS wiring harnesses can be identified by yellow and/or orange harnesses or harness connectors.

PRECAUTIONS WHEN USING POWER TOOLS (AIR OR ELECTRIC) AND HAMMERS

WARNING:

Always observe the following items for preventing accidental activation.

- When working near the Air Bag Diagnosis Sensor Unit or other Air Bag System sensors with the ignition ON or engine running, never use air or electric power tools or strike near the sensor(s) with a hammer. Heavy vibration could activate the sensor(s) and deploy the air bag(s), possibly causing serious injury.
- When using air or electric power tools or hammers, always switch the ignition OFF, disconnect the battery, and wait at least 3 minutes before performing any service.

FOR USA AND CANADA : Precaution for Procedure without Cowl Top Cover

INFOID:000000008280193

When performing the procedure after removing cowl top cover, cover the lower end of windshield with urethane, etc to prevent damage to windshield.

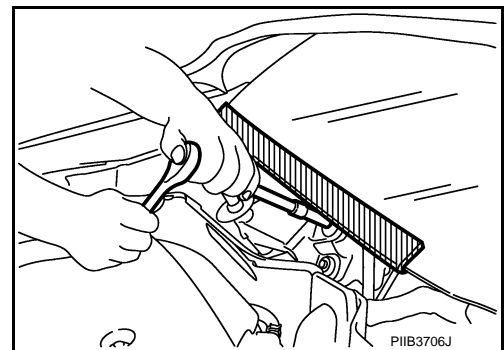

FOR USA AND CANADA : Precautions for Suspension

INFOID:000000008280194

- When installing rubber bushings, the final tightening must be carried out under unladen conditions with tires on ground. Spilled oil might shorten the life of rubber bushings. Be sure to wipe off any spilled oil.
- Unladen conditions mean that fuel, engine coolant and lubricant are full. Spare tire, jack, hand tools and mats are in designated positions.
- After servicing suspension parts, be sure to check wheel alignment.
- Self-lock nuts are not reusable. Always use new ones when installing. Since new self-lock nuts are pre-oiled, tighten as they are.

A
B
C
D
FSU
F
G
H
I
J
K
L
M
N
O
P

PRECAUTIONS

< PRECAUTION >

FOR MEXICO

FOR MEXICO : Precaution for Supplemental Restraint System (SRS) "AIR BAG" and "SEAT BELT PRE-TENSIONER"

INFOID:000000008280195

The Supplemental Restraint System such as "AIR BAG" and "SEAT BELT PRE-TENSIONER", used along with a front seat belt, helps to reduce the risk or severity of injury to the driver and front passenger for certain types of collision. Information necessary to service the system safely is included in the "SRS AIR BAG" and "SEAT BELT" of this Service Manual.

WARNING:

Always observe the following items for preventing accidental activation.

- To avoid rendering the SRS inoperative, which could increase the risk of personal injury or death in the event of a collision that would result in air bag inflation, all maintenance must be performed by an authorized NISSAN/INFINITI dealer.
- Improper maintenance, including incorrect removal and installation of the SRS, can lead to personal injury caused by unintentional activation of the system. For removal of Spiral Cable and Air Bag Module, see "SRS AIR BAG".
- Never use electrical test equipment on any circuit related to the SRS unless instructed to in this Service Manual. SRS wiring harnesses can be identified by yellow and/or orange harnesses or harness connectors.

PRECAUTIONS WHEN USING POWER TOOLS (AIR OR ELECTRIC) AND HAMMERS

WARNING:

Always observe the following items for preventing accidental activation.

- When working near the Air Bag Diagnosis Sensor Unit or other Air Bag System sensors with the ignition ON or engine running, never use air or electric power tools or strike near the sensor(s) with a hammer. Heavy vibration could activate the sensor(s) and deploy the air bag(s), possibly causing serious injury.
- When using air or electric power tools or hammers, always switch the ignition OFF, disconnect the battery, and wait at least 3 minutes before performing any service.

FOR MEXICO : Precaution for Procedure without Cowl Top Cover

INFOID:000000008280196

When performing the procedure after removing cowl top cover, cover the lower end of windshield with urethane, etc to prevent damage to windshield.

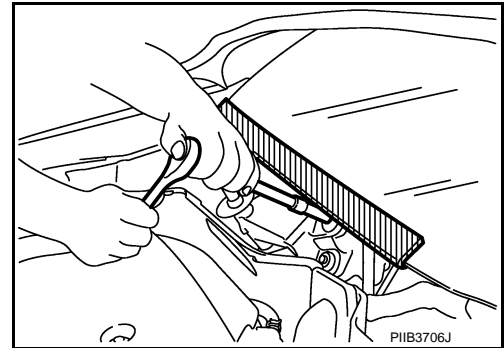

FOR MEXICO : Precautions for Suspension

INFOID:000000008280197

- When installing rubber bushings, the final tightening must be carried out under unladen conditions with tires on ground. Spilled oil might shorten the life of rubber bushings. Be sure to wipe off any spilled oil.
- Unladen conditions mean that fuel, engine coolant and lubricant are full. Spare tire, jack, hand tools and mats are in designated positions.
- After servicing suspension parts, be sure to check wheel alignment.
- Self-lock nuts are not reusable. Always use new ones when installing. Since new self-lock nuts are pre-oiled, tighten as they are.

PREPARATION

< PREPARATION >

PREPARATION

PREPARATION

Special Service Tool

INFOID:0000000008280198

The actual shapes of Kent-More tools may differ from those of special service tools illustrated here.

| Tool number (Kent-More No.) Tool name | Description |
|---|------------------------------------|
| ST35652000 (—) Strut attachment | Disassembling and assembling strut |

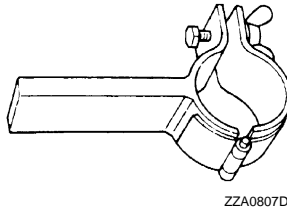

A
B
C
D
FSU

Commercial Service Tool

INFOID:0000000008280199

| Tool name | Description |
|-------------------|-------------------------------------|
| Spring compressor | Removing and installing coil spring |
| Power tool | Loosening bolts and nuts |

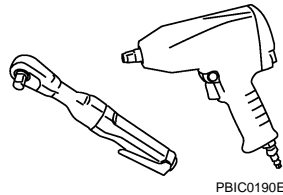
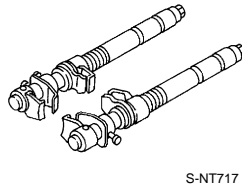

F
G
H
I
J
K
L
M
N
O
P

FRONT SUSPENSION ASSEMBLY

< PERIODIC MAINTENANCE >

PERIODIC MAINTENANCE

FRONT SUSPENSION ASSEMBLY

Inspection

INFOID:000000008280200

COMPONENT PART

Check the mounting conditions (looseness, backlash) of each component and component conditions (wear, damage) are normal.

Ball Joint Axial End Play

1. Set front wheels in a straight-ahead position.
2. Move axle side of transverse link in the axial direction by hand. Check there is no end play.

Standard

End play : Refer to [FSU-20, "Ball Joint"](#).

CAUTION:

- Never depress brake pedal when measuring.
- Never perform with tires on level ground.
- Be careful not to damage ball joint boot. Never damage the installation position by applying excessive force.

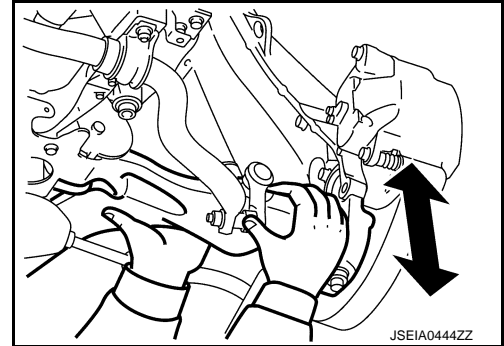

STRUT ASSEMBLY

Check for oil leakage and damage, and replace if necessary.

WHEEL ALIGNMENT

< PERIODIC MAINTENANCE >

WHEEL ALIGNMENT

Inspection

INFOID:000000008280201

DESCRIPTION

CAUTION:

- **Camber, caster, kingpin inclination angles cannot be adjusted.**
- **If camber, caster, or kingpin inclination angle is outside the standard, check front suspension parts for wear and damage. Replace suspect parts if a malfunction is detected.**
- **Kingpin inclination angle is reference value, no inspection is required.**
- Measure wheel alignment under unladen conditions.

NOTE:

“Unladen conditions” means that fuel, engine coolant, and lubricant are full. Spare tire, jack, hand tools and mats are in designated positions.

PRELIMINARY CHECK

Check the following:

- Tires for improper air pressure and wear. Refer to [WT-50, "Tire Air Pressure"](#).
- Road wheels for runout.
- Wheel bearing axial end play. Refer to [FAX-11, "Inspection"](#) (2WD), [FAX-37, "Inspection"](#) (AWD).
- Transverse link ball joint axial end play. Refer to [FSU-6, "Inspection"](#).
- Shock absorber operation.
- Each mounting part of axle and suspension for looseness and deformation.
- Each of suspension member, shock absorber and transverse link for cracks, deformation and other damage.
- Vehicle height (posture).

GENERAL INFORMATION AND RECOMMENDATIONS

- A four-wheel thrust alignment should be performed.
- This type of alignment is recommended for any NISSAN/INFINITI vehicle.
- The four-wheel “thrust” process helps ensure that the vehicle is properly aligned and the steering wheel is centered.
- The alignment rack itself should be capable of accepting any NISSAN/INFINITI vehicle.
- The rack should be checked to ensure that it is level.
- Make sure the machine is properly calibrated.
- Your alignment equipment should be regularly calibrated in order to give correct information.
- Check with the manufacturer of your specific equipment for their recommended Service/Calibration Schedule.

ALIGNMENT PROCESS

IMPORTANT:

Use only the alignment specifications listed in this Service Manual.

- When displaying the alignment settings, many alignment machines use “indicators”: (Green/red, plus or minus, Go/No Go). **Do not use these indicators.**
- The alignment specifications programmed into your machine that operate these indicators may not be correct.
- This may result in an ERROR.
- Most camera-type alignment machines are equipped with both “Rolling Compensation” method and optional “Jacking Compensation” method to “compensate” the alignment targets or head units. “Rolling Compensation” is the preferred method.
- If using the “Rolling Compensation” method, after installing the alignment targets or head units, push or pull on the rear wheel to move the vehicle. **Do not push or pull on the vehicle body.**
- If using the “Jacking Compensation” method, after installing the alignment targets or head units, raise the vehicle and rotate the wheels 1/2 turn both ways.

NOTE:

- Do not use the “Rolling Compensation” method if you are using sensor-type alignment equipment.
- Follow all instructions for the alignment machine you're using for more information.

Adjustment

INFOID:000000008280202

TOE-IN

- Loosen the steering outer socket, and then adjust the length using steering inner socket.

WHEEL ALIGNMENT

< PERIODIC MAINTENANCE >

Standard

Toe-in : Refer to [FSU-20, "Wheel Alignment"](#).

CAUTION:

- Always evenly adjust both toe-in alternately and adjust the difference between the left and right to the standard.
- Always fix the steering inner socket when tightening the steering outer socket.
- After toe-in adjustment, adjust neutral position of steering angle sensor. (With VDC) Refer to [BRC-76, "ADJUSTMENT OF STEERING ANGLE SENSOR NEUTRAL POSITION : Special Repair Requirement"](#).

FRONT COIL SPRING AND STRUT

< REMOVAL AND INSTALLATION >

REMOVAL AND INSTALLATION

FRONT COIL SPRING AND STRUT

Exploded View

INFOID:000000008280203

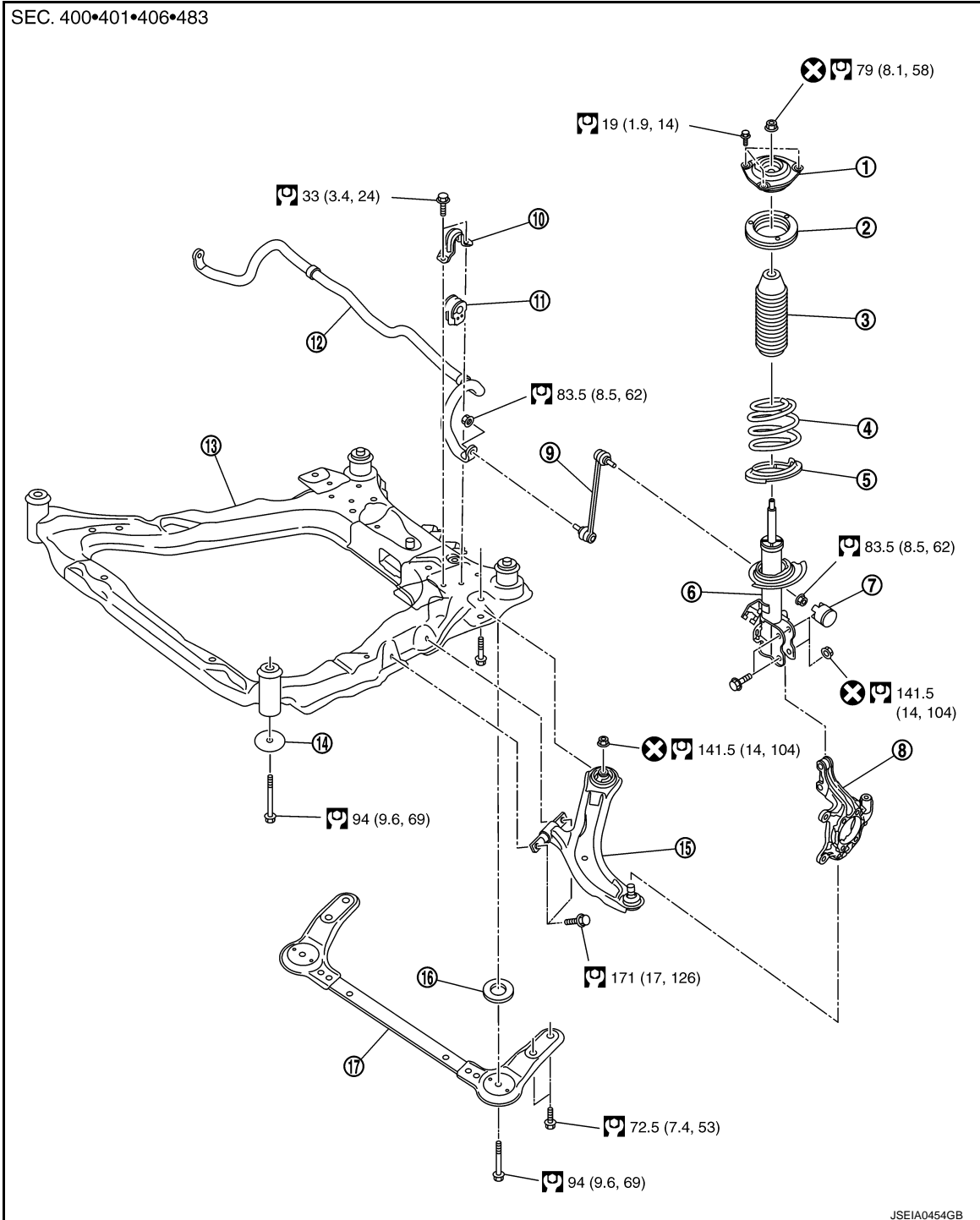

- | | | |
|-----------------------------|-------------------------------|------------------------------|
| 1. Strut mounting insulator | 2. Strut mounting bearing | 3. Bound bumper |
| 4. Coil spring | 5. Lower rubber seat | 6. Strut |
| 7. Cap | 8. Steering knuckle | 9. Stabilizer connecting rod |
| 10. Stabilizer clamp | 11. Stabilizer bushing | 12. Stabilizer bar |
| 13. Front suspension member | 14. Rebound stopper insulator | 15. Transverse link |

A
B
C
D
E
F
G
H
I
J
K
L
M
N
O
P

FSU

FRONT COIL SPRING AND STRUT

< REMOVAL AND INSTALLATION >

16. Rebound stopper
17. Front suspension member stay
- Refer to [GI-4, "Components"](#) for symbols in the figure.

Removal and Installation

INFOID:000000008280204

REMOVAL

1. Remove tires with power tool.
2. Remove lock plat. Refer to [BR-21, "FRONT : Exploded View"](#).
3. Remove cap and mounting nut on the upper side of stabilizer connecting rod, and then remove stabilizer connecting rod from strut assembly with power tool.
4. Separate steering knuckle from strut assembly.
5. Remove mounting bolts of strut mounting insulator, and then remove strut assembly with power tool.

INSTALLATION

Note the following, and install in the reverse order of removal.

- Become it in arrow mark (B) for identification mark (A) an illustration to the body outside.

⇐ : Vehicle front

- Perform final tightening of bolts and nuts, under unladen conditions with tires on level ground.

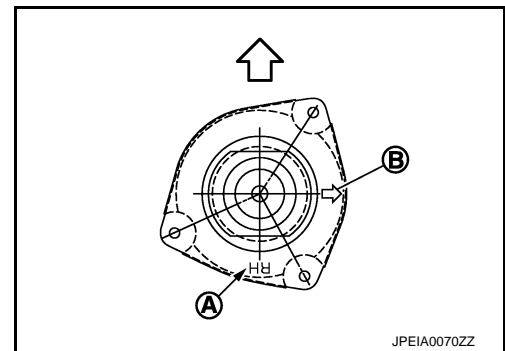

Disassembly and Assembly

INFOID:000000008280205

DISASSEMBLY

CAUTION:

Never damage strut assembly piston rod when removing components from strut assembly.

1. Install strut attachment (A) [SST: ST35652000 (—)] to strut assembly and secure it in a vise.

CAUTION:

When installing the strut attachment to strut assembly, wrap a shop cloth around strut to protect from damage.

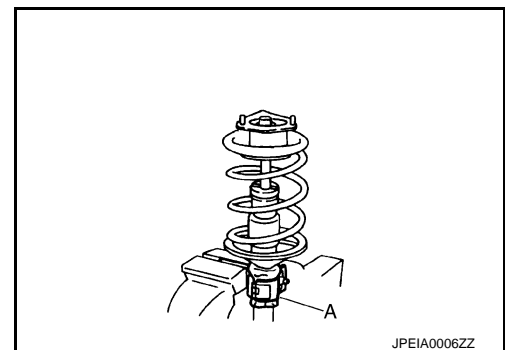

2. Using a spring compressor (A) (commercial service tool), compress coil spring between strut mounting bearing and lower rubber seat (on strut assembly) until coil spring with a spring compressor is free.

CAUTION:

Be sure a spring compressor is securely attached to coil spring. Compress coil spring.

3. Make sure coil spring with a spring compressor between strut mounting bearing and lower rubber seat (strut assembly) is free. And then remove piston rod lock nut while securing the piston rod tip so that piston rod does not turn.
4. Remove strut mounting insulator and strut mounting bearing, and bound bumper from strut.

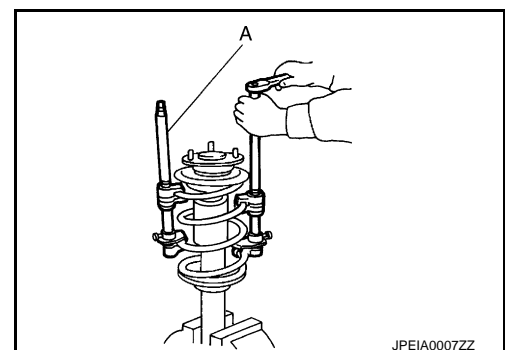

FRONT COIL SPRING AND STRUT

< REMOVAL AND INSTALLATION >

- After remove coil spring with a spring compressor (commercial service tool), and then gradually release a spring compressor.
CAUTION:
Loosen while making sure coil spring attachment position does not move.
- Remove lower rubber seat from strut.
- Remove the strut attachment [SST: ST35652000 (—)] from strut.

ASSEMBLY

- Install strut attachment [SST: ST35652000 (—)] to strut and secure it in a vise.
CAUTION:
When installing the strut attachment to strut assembly, wrap a shop cloth around strut to protect from damage.
- Install lower rubber seat.
- Install bound bumper onto strut mounting insulator.
- Compress coil spring using a spring compressor (commercial service tool), and install it onto strut assembly.
CAUTION:
 - Face tube side of coil spring (1) downward. Align the lower end (A) to lower rubber seat (2).
 - Be sure a compressor is securely attached to coil spring. Compress coil spring.
 - Set coil spring so that its paint marks are aligned with the positions of 1.75 turns and 2.75 turns from the bottom end of the coil spring.

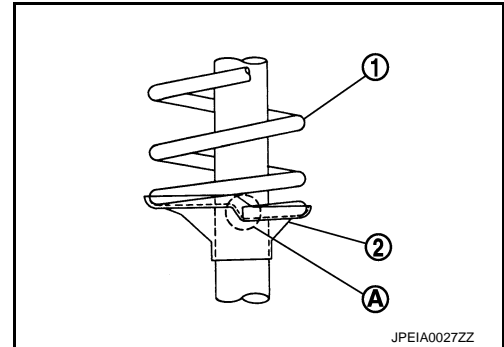

- Install strut mounting bearing and strut mounting insulator with bound bumper to strut.
 - Installation position of strut mounting insulator is shown in the figure.

- A : Identification mark
B : Arrow mark
⇐ : Vehicle front

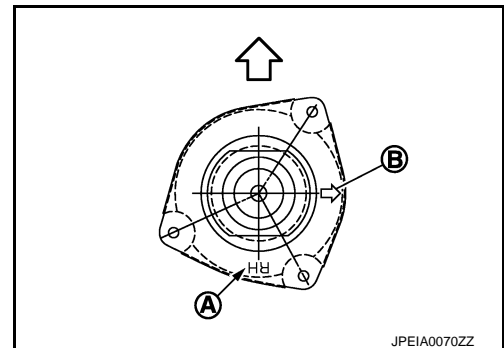

- Secure piston rod tip so that piston rod does not turn, then tighten piston rod lock nut with specified torque.
CAUTION:
Never reuse piston rod lock nut.
- Gradually release a spring compressor (commercial service tool), and remove coil spring.
CAUTION:
Loosen while making sure coil spring attachment position does not move.
- Remove the strut attachment [SST: ST35652000 (—)] from strut assembly.

Inspection

INFOID:000000008280206

INSPECTION AFTER INSTALLATION

Check wheel alignment. Refer to [FSU-7, "Inspection"](#).

INSPECTION AFTER DISASSEMBLY

Strut

Check the following items, and replace the parts if necessary.

- Strut for deformation, cracks or damage
- Piston rod for damage, uneven wear or distortion
- Oil leakage

FRONT COIL SPRING AND STRUT

< REMOVAL AND INSTALLATION >

Strut Mounting Insulator and Rubber Parts Inspection

Check strut mounting insulator for cracks and rubber parts for wear. Replace it if necessary.

Coil Spring

Check coil spring for cracks, wear or damage. Replace it if necessary.

Disposal

INFOID:000000008280207

1. Set strut assembly horizontally to the ground with the piston rod fully extracted.
2. Drill 2 – 3 mm (0.08 – 0.12 in) hole at the position (●) from top as shown in the figure to release gas gradually.

CAUTION:

- Wear eye protection (safety glasses).
- Wear gloves.
- Be careful with metal chips or oil blown out by the compressed gas.

NOTE:

- Drill vertically in this direction (←).
- Directly to the outer tube avoiding brackets.
- The gas is clear, colorless, odorless, and harmless.

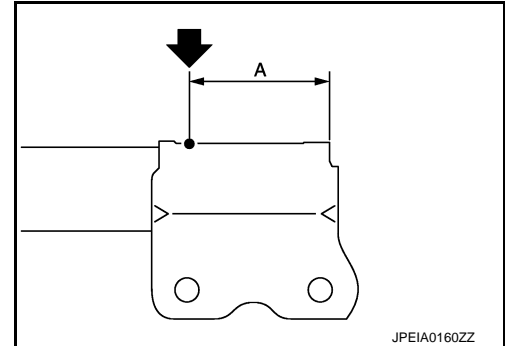

A: 20 – 30 mm (0.79 – 1.18 in)

3. Position the drilled hole downward and drain oil by moving the piston rod several times.

CAUTION:

Dispose of drained oil according to the law and local regulations.

TRANSVERSE LINK

< REMOVAL AND INSTALLATION >

TRANSVERSE LINK

Exploded View

INFOID:000000008280208

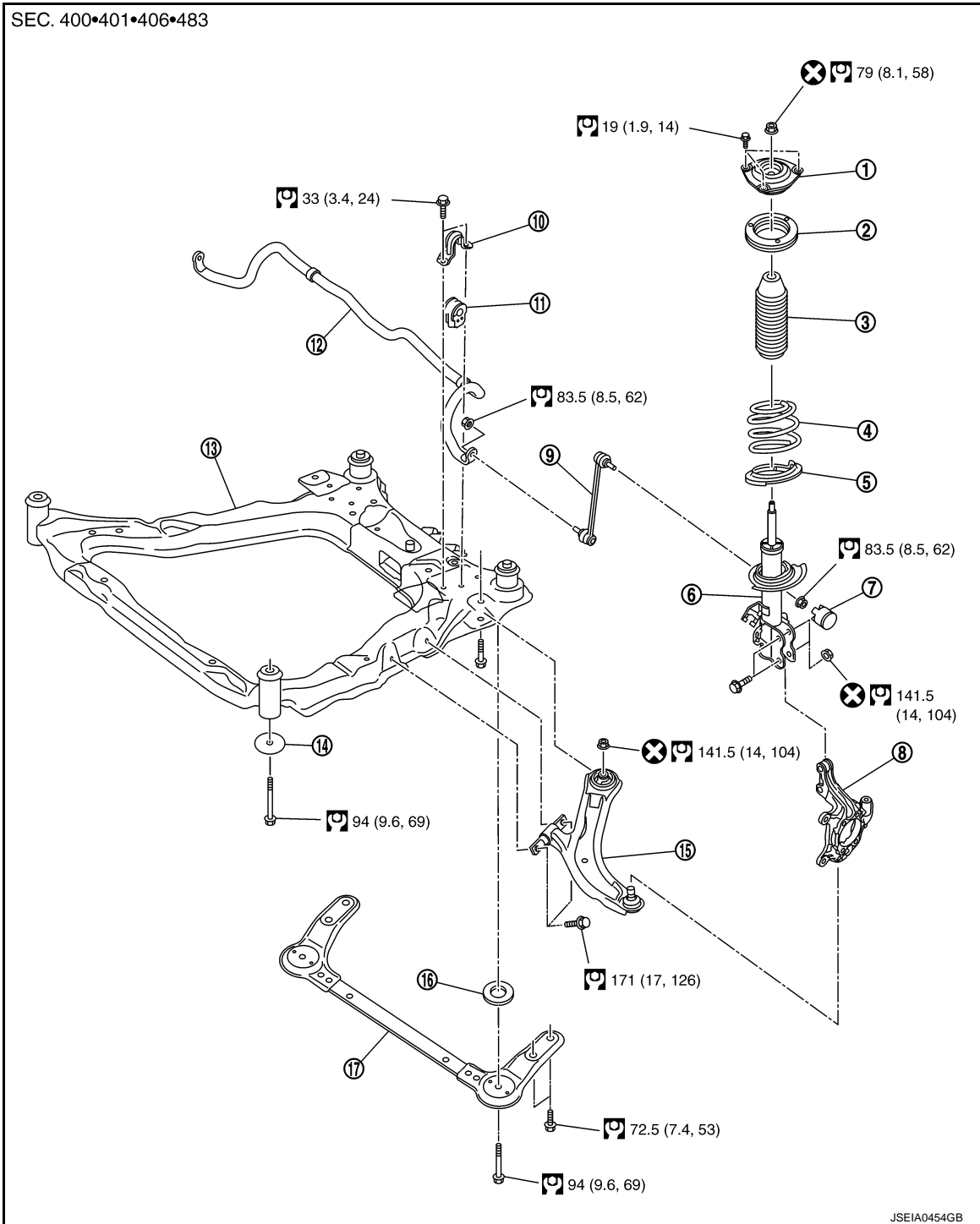

- | | | |
|-----------------------------|----------------------------------|------------------------------|
| 1. Strut mounting insulator | 2. Strut mounting bearing | 3. Bound bumper |
| 4. Coil spring | 5. Lower rubber seat | 6. Strut |
| 7. Cap | 8. Steering knuckle | 9. Stabilizer connecting rod |
| 10. Stabilizer clamp | 11. Stabilizer bushing | 12. Stabilizer bar |
| 13. Front suspension member | 14. Rebound stopper insulator | 15. Transverse link |
| 16. Rebound stopper | 17. Front suspension member stay | |

Refer to [GI-4, "Components"](#) for symbols in the figure.

TRANSVERSE LINK

< REMOVAL AND INSTALLATION >

Removal and Installation

INFOID:000000008280209

REMOVAL

1. Remove tires with power tool.
2. Remove transverse link from steering knuckle. Refer to [FAX-9, "Exploded View"](#) (2WD), [FAX-35, "Exploded View"](#) (AWD).
3. Remove transverse link from suspension member.

NOTE:

Transverse link cannot be pulled out because the mounting bolt (←) of transverse link at the rear of the mounting area located on the front side of vehicle hits against the stabilizer bar. Therefore, get stabilizer bar out of the way to remove the transverse link.

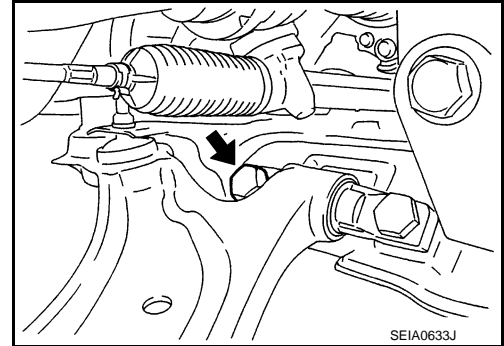

INSTALLATION

Note the following, and install in the reverse order of removal.

- Perform final tightening of bolts and nuts at the front suspension member, under unladen conditions with tires on level ground.

Inspection

INFOID:000000008280210

INSPECTION AFTER REMOVAL

Visual Inspection

Check the following:

- Transverse link and bushing for deformation, cracks or damage. Replace it if necessary.
- Ball joint boot for cracks or other damage, and also for grease leakage. Replace it if necessary.

Ball Joint Inspection

Manually move ball stud to confirm it moves smoothly with no binding.

Swing Torque Inspection

NOTE:

Before measurement, move ball stud at least ten times by hand to check for smooth movement.

- Hook a spring balance (A) at cutout (B) on ball stud. Confirm spring balance measurement value is within specifications when ball stud begins moving.

Standard

Swing torque :Refer to [FSU-20, "Ball Joint"](#).

Spring balance measurement :Refer to [FSU-20, "Ball Joint"](#).

- If swing torque exceeds standard range, replace transverse link assembly.

Axial End Play Inspection

- Move tip of ball stud in axial direction to check for looseness.

Standard

Axial end play :Refer to [FSU-20, "Ball Joint"](#).

- If axial end play exceeds the standard value, replace transverse link assembly.

INSPECTION AFTER INSTALLATION

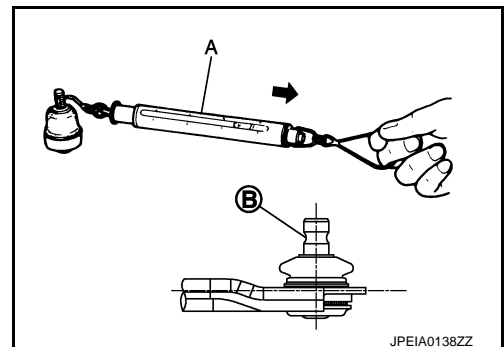

TRANSVERSE LINK

< REMOVAL AND INSTALLATION >

Check wheel alignment. Refer to [FSU-7, "Inspection"](#).

A

B

C

D

FSU

F

G

H

I

J

K

L

M

N

O

P

FRONT STABILIZER

< REMOVAL AND INSTALLATION >

FRONT STABILIZER

Exploded View

INFOID:000000008280211

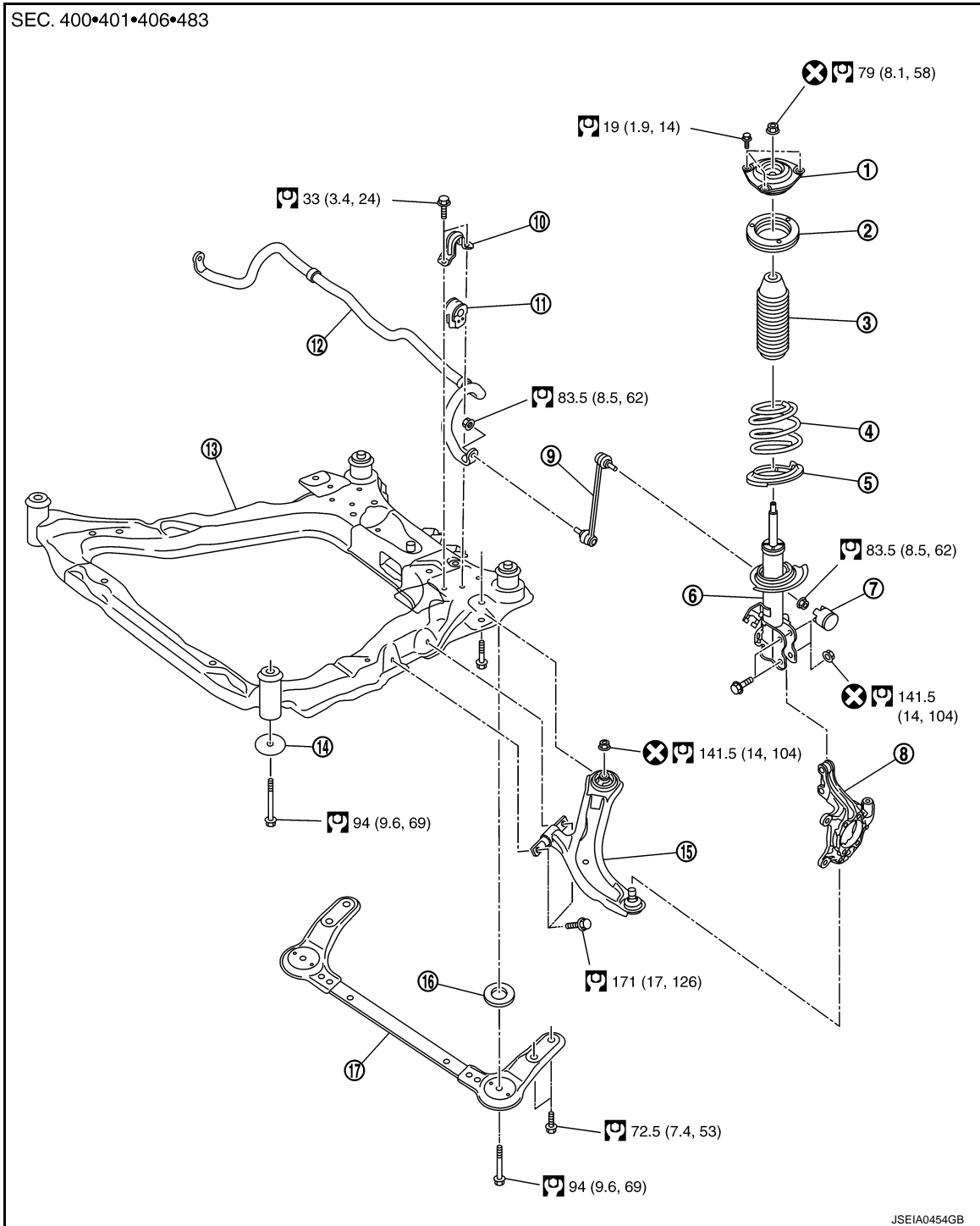

- | | | |
|-----------------------------|----------------------------------|------------------------------|
| 1. Strut mounting insulator | 2. Strut mounting bearing | 3. Bound bumper |
| 4. Coil spring | 5. Lower rubber seat | 6. Strut |
| 7. Cap | 8. Steering knuckle | 9. Stabilizer connecting rod |
| 10. Stabilizer clamp | 11. Stabilizer bushing | 12. Stabilizer bar |
| 13. Front suspension member | 14. Rebound stopper insulator | 15. Transverse link |
| 16. Rebound stopper | 17. Front suspension member stay | |

Refer to [GI-4. "Components"](#) for symbols in the figure.

FRONT STABILIZER

< REMOVAL AND INSTALLATION >

Removal and Installation

INFOID:000000008280212

REMOVAL

1. Remove tires power tool.
2. Remove under cover from vehicle.
3. Remove steering outer socket from steering knuckle. Refer to [ST-13. "Exploded View"](#).
4. Remove stabilizer connecting rod.
5. Remove rear torque rod. Refer to [EM-62. "Exploded View"](#).
6. Separate intermediate shaft from steering gear. Refer to [ST-10. "Exploded View"](#).
7. Set suitable jack under front suspension member.
8. Remove front suspension member stay from vehicle.
9. Gradually lower jack front suspension member in order to remove stabilizer mounting bolts.

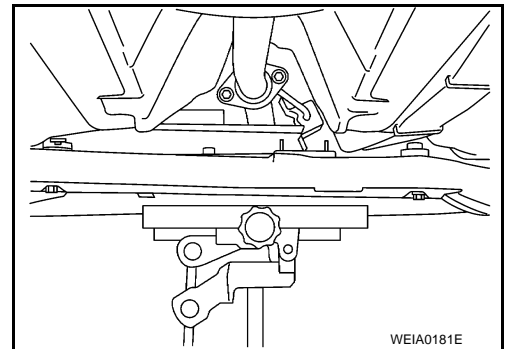

10. Remove mounting bolts (←) of stabilizer clamp, and then remove stabilizer clamp and stabilizer bushing from front suspension member.
11. Remove stabilizer bar.

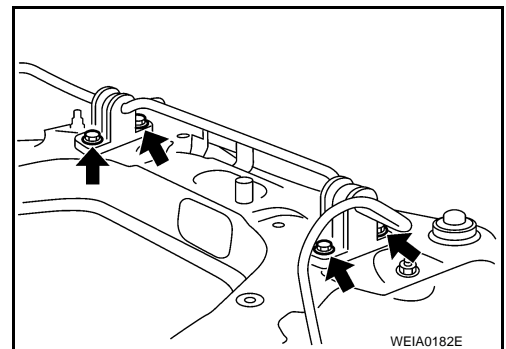

INSTALLATION

Note the following, and install in the reverse order of removal.

- Install stabilizer clamp that notch (A) becomes vehicle front side (←).
- Install stabilizer bushing that slit (B) becomes vehicle front side (←).

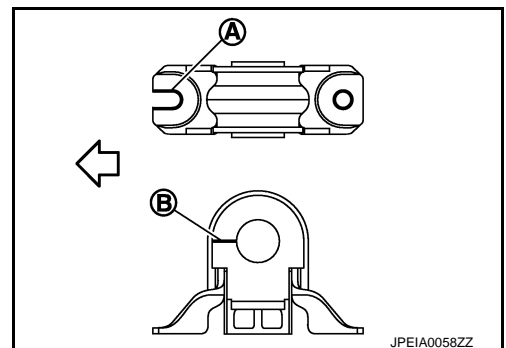

Inspection

INFOID:000000008280213

INSPECTION AFTER REMOVAL

Check stabilizer bar, stabilizer connecting rod, stabilizer bushing and stabilizer clamp for deformation, cracks or damage. Replace it if necessary.

FRONT SUSPENSION MEMBER

< UNIT REMOVAL AND INSTALLATION >

UNIT REMOVAL AND INSTALLATION

FRONT SUSPENSION MEMBER

Exploded View

INFOID:000000008280214

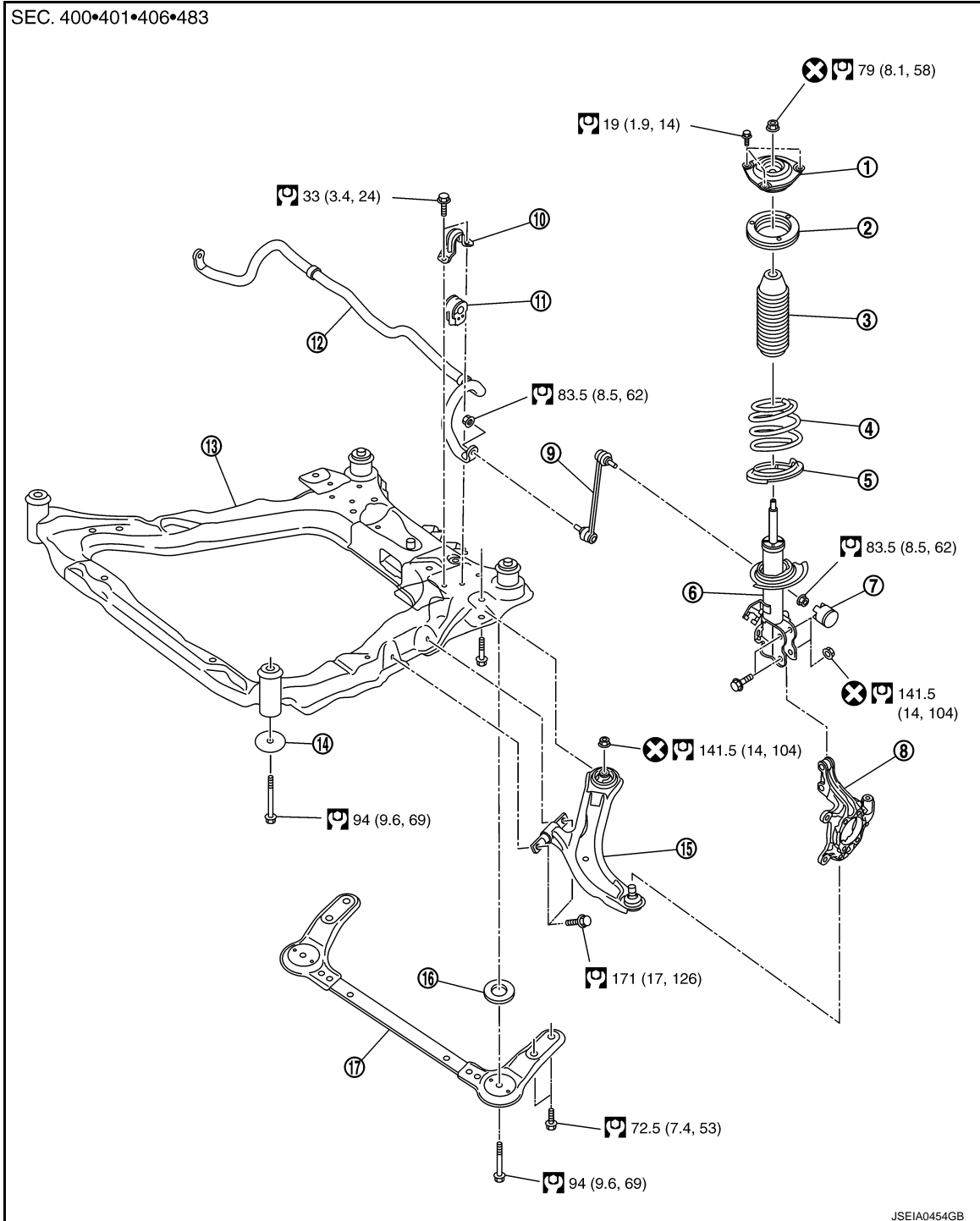

- | | | |
|-----------------------------|-------------------------------|------------------------------|
| 1. Strut mounting insulator | 2. Strut mounting bearing | 3. Bound bumper |
| 4. Coil spring | 5. Lower rubber seat | 6. Strut |
| 7. Cap | 8. Steering knuckle | 9. Stabilizer connecting rod |
| 10. Stabilizer clamp | 11. Stabilizer bushing | 12. Stabilizer bar |
| 13. Front suspension member | 14. Rebound stopper insulator | 15. Transverse link |

FRONT SUSPENSION MEMBER

< UNIT REMOVAL AND INSTALLATION >

16. Rebound stopper
17. Front suspension member stay
- Refer to [GI-4, "Components"](#) for symbols in the figure.

Removal and Installation

INFOID:000000008280215

REMOVAL

1. Remove tires with power tool.
2. Remove under cover from vehicle.
3. Remove wheel sensor from steering knuckle. Refer to [BRC-66, "FRONT WHEEL SENSOR : Exploded View"](#) (without VDC), [BRC-177, "FRONT WHEEL SENSOR : Exploded View"](#) (with VDC).
CAUTION:
Never pull on wheel sensor harness.
4. Remove upper side of stabilizer connecting rod from strut assembly.
5. Remove steering outer socket from steering knuckle. Refer to [ST-13, "Exploded View"](#).
6. Separate intermediate shaft from steering gear. Refer to [ST-10, "Exploded View"](#).
7. Remove transverse link from steering knuckle. Refer to [FAX-9, "Exploded View"](#) (2WD), [FAX-35, "Exploded View"](#) (AWD).
8. Remove rear torque rod. Refer to [EM-62, "Exploded View"](#).
9. Set suitable jack front suspension member.
10. Remove front suspension member stay from vehicle.
11. Remove mounting bolts and nuts of front suspension member.
12. Gradually lower jack to remove front suspension assembly from vehicle.
CAUTION:
Secure suspension assembly to suitable jack while removing it.
13. Remove mounting bolts and nuts, and then remove transverse link, stabilizer bar from front suspension member.

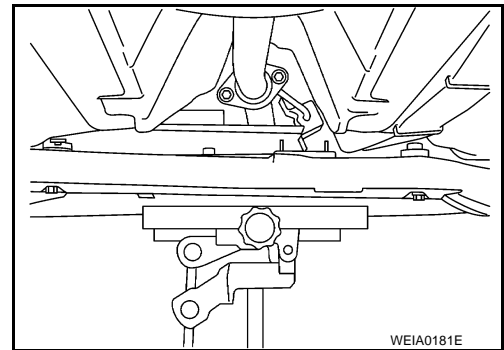

INSTALLATION

Note the following, and install in the reverse order of removal.

- Perform final tightening of installation position between front suspension member and transverse links (rubber bushing) under unladen condition with tires on level ground.
- Check wheel sensor harness for proper connection. Refer to [BRC-66, "FRONT WHEEL SENSOR : Exploded View"](#) (without VDC), [BRC-177, "FRONT WHEEL SENSOR : Exploded View"](#) (with VDC).

Inspection

INFOID:000000008280216

INSPECTION AFTER REMOVAL

Check the front suspension member for significant deformation, cracks, or damages. Replace it if necessary.

INSPECTION AFTER INSTALLATION

Check wheel alignment. Refer to [FSU-7, "Inspection"](#).

SERVICE DATA AND SPECIFICATIONS (SDS)

< SERVICE DATA AND SPECIFICATIONS (SDS)

SERVICE DATA AND SPECIFICATIONS (SDS)

SERVICE DATA AND SPECIFICATIONS (SDS)

Wheel Alignment

INFOID:0000000008280217

| Item | | Standard | | | | | |
|---|---|------------------------|--------------------------|---------|---------|---------|---------|
| Axle type | | 2WD | | | AWD | | |
| Wheel size | | 16 inch | 17 inch | 18 inch | 16 inch | 17 inch | 18 inch |
| Camber Degree minute (Decimal degree) | Minimum | Left side | -1° 00' (-1.00°) | | | | |
| | | Right side | -1° 15' (-1.25°) | | | | |
| | Nominal | Left side | -0° 15' (-0.25°) | | | | |
| | | Right side | -0° 30' (-0.50°) | | | | |
| | Maximum | Left side | 0° 30' (0.50°) | | | | |
| | | Right side | 0° 15' (0.25°) | | | | |
| Left and right difference | | 0° 33' (0.55°) or less | | | | | |
| Caster Degree minute (Decimal degree) | Minimum | 3° 55' (3.92°) | 4° 00' (4.00°) | | | | |
| | Nominal | 4° 40' (4.67°) | 4° 45' (4.75°) | | | | |
| | Maximum | 5° 25' (5.41°) | 5° 30' (5.50°) | | | | |
| | Left and right difference | 0° 36' (0.60°) or less | | | | | |
| Kingpin inclination Degree minute (Decimal degree) | Minimum | 9° 45' (9.75°) | | | | | |
| | Nominal | 10° 30' (10.50°) | | | | | |
| | Maximum | 11° 15' (11.25°) | | | | | |
| Toe-in | Total toe-in Distance | Minimum | 0 mm (0.00 in) | | | | |
| | | Nominal | In 2 mm (In 0.08 in) | | | | |
| | | Maximum | In 4 mm (In 0.15 in) | | | | |
| | Total toe-angle Degree minute (Decimal degree) | Minimum | 0° 00' 00" (0.00°) | | | | |
| | | Nominal | In 0° 09' 36" (In 0.16°) | | | | |
| | | Maximum | In 0° 19' 48" (In 0.33°) | | | | |

Measure value under unladen* conditions.

*: Fuel, engine coolant and lubricant are full. Spare tire, jack, hand tools and mats are in designated positions.

Ball Joint

INFOID:0000000008280218

| Item | | Standard |
|-------------------------------|-----------------|--|
| Swing torque | Transverse link | 0.5 – 3.4 N·m (0.06 – 0.34 kg·m, 5 – 30 in-lb) |
| Measurement on spring balance | Transverse link | 13.5 – 91.9 N (1.4 – 9.3 kg, 3 – 21 lb) |
| Axial end play | | 0 mm (0 in) |

Wheelarch Height

INFOID:0000000008280219

| Wheel size | Front (Hf) | Rear (Hr) |
|------------|-------------------|-------------------|
| 16 inch | 789 mm (31.06 in) | 811 mm (31.93 in) |
| 17 inch | 788 mm (31.02 in) | 810 mm (31.89 in) |

SERVICE DATA AND SPECIFICATIONS (SDS)

< SERVICE DATA AND SPECIFICATIONS (SDS)

| Wheel size | Front (Hf) | Rear (Hr) |
|------------|-------------------|-------------------|
| 18 inch | 792 mm (31.18 in) | 813 mm (32.01 in) |

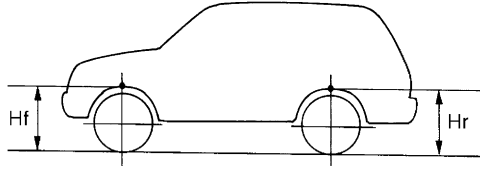

SFA746B

Measure value under unladen* conditions.

*: Fuel, engine coolant and lubricant are full. Spare tire, jack, hand tools and mats are in designated positions.

A
B
C
D
F
G
H
I
J
K
L
M
N
O
P

FSU