

SECTION **EXT**
EXTERIOR

A
B
C
D
E
F
G
H
I
J
EXT
L
M
N
O
P

CONTENTS

PRECAUTION	3	FENDER PROTECTOR	28
PRECAUTIONS	3	FENDER PROTECTOR	28
Precaution for Supplemental Restraint System (SRS) "AIR BAG" and "SEAT BELT PRE-TENSIONER"	3	FENDER PROTECTOR : Exploded View	28
Precaution for Procedure without Cowl Top Cover.....	3	FENDER PROTECTOR : Removal and Installation	28
Precaution for Work	3	REAR WHEEL HOUSE PROTECTOR	29
PREPARATION	5	REAR WHEEL HOUSE PROTECTOR : Exploded View	29
PREPARATION	5	REAR WHEEL HOUSE PROTECTOR : Removal and Installation	29
Special Service Tool	5	OVER FENDER	30
Commercial Service Tool	5	FRONT OVER FENDER	30
CLIP LIST	6	FRONT OVER FENDER : Exploded View	30
Descriptions for Clips	6	FRONT OVER FENDER : Removal and Installation	30
SYMPTOM DIAGNOSIS	10	REAR OVER FENDER	31
SQUEAK AND RATTLE TROUBLE DIAGNOSES	10	REAR OVER FENDER : Exploded View	32
Work Flow	10	REAR OVER FENDER : Removal and Installation.....	32
Generic Squeak and Rattle Troubleshooting	11	MUDGUARD	34
Diagnostic Worksheet	14	Exploded View	34
REMOVAL AND INSTALLATION	16	Removal and Installation	34
FRONT BUMPER	16	Exploded View - Center Mudguard	35
Exploded View	16	Removal and Installation - Center Mudguard	35
Removal and Installation	17	UNDER COVER	37
REAR BUMPER	20	Exploded View	37
Exploded View	20	ENGINE UNDER COVER	37
Removal and Installation	20	ENGINE UNDER COVER : Removal and Installation	37
FRONT GRILLE	23	FLOOR UNDER COVER	37
Exploded View	23	FLOOR UNDER COVER : Removal and Installation	37
Removal and Installation	23	ROOF SIDE MOLDING	39
COWL TOP	25	Exploded View	39
Exploded View	25		
Removal and Installation	25		

Removal and Installation	39	DOOR OUTSIDE LOWER MOLDING	45
DOOR SASH MOLDING	40	Exploded View	45
Exploded View	40	Removal and Installation	45
Removal and Installation	40	REAR SPOILER	47
DOOR OUTSIDE MOLDING	42	Removal and Installation	47
Exploded View	42	SIDE AIR SPOILER	48
Removal and Installation	42	Exploded View	48
ROOF RACK	44	Removal and Installation	48
Exploded View	44	BACK DOOR OUTER FINISHER	50
Removal and Installation	44	Exploded View	50
		Removal and Installation	50

PRECAUTIONS

< PRECAUTION >

PRECAUTION

PRECAUTIONS

Precaution for Supplemental Restraint System (SRS) "AIR BAG" and "SEAT BELT PRE-TENSIONER"

INFOID:000000010249311

The Supplemental Restraint System such as "AIR BAG" and "SEAT BELT PRE-TENSIONER", used along with a front seat belt, helps to reduce the risk or severity of injury to the driver and front passenger for certain types of collision. Information necessary to service the system safely is included in the SR and SB section of this Service Manual.

WARNING:

- To avoid rendering the SRS inoperative, which could increase the risk of personal injury or death in the event of a collision which would result in air bag inflation, all maintenance must be performed by an authorized NISSAN/INFINITI dealer.
- Improper maintenance, including incorrect removal and installation of the SRS, can lead to personal injury caused by unintentional activation of the system. For removal of Spiral Cable and Air Bag Module, see the SR section.
- Do not use electrical test equipment on any circuit related to the SRS unless instructed to in this Service Manual. SRS wiring harnesses can be identified by yellow and/or orange harnesses or harness connectors.

PRECAUTIONS WHEN USING POWER TOOLS (AIR OR ELECTRIC) AND HAMMERS

WARNING:

- When working near the Airbag Diagnosis Sensor Unit or other Airbag System sensors with the Ignition ON or engine running, DO NOT use air or electric power tools or strike near the sensor(s) with a hammer. Heavy vibration could activate the sensor(s) and deploy the air bag(s), possibly causing serious injury.
- When using air or electric power tools or hammers, always switch the Ignition OFF, disconnect the battery and wait at least three minutes before performing any service.

Precaution for Procedure without Cowl Top Cover

INFOID:000000010249312

When performing the procedure after removing cowl top cover, cover the lower end of windshield with urethane, etc to prevent damage to windshield.

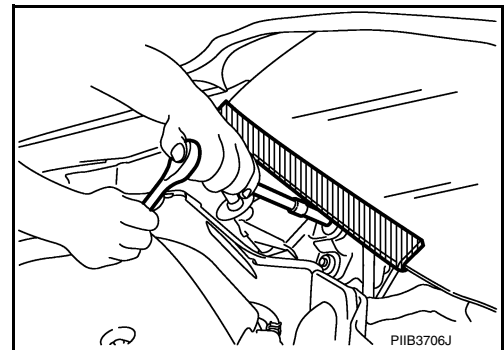

Precaution for Work

INFOID:000000010249313

- When removing or disassembling each component, be careful not to damage or deform it. If a component may be subject to interference, be sure to protect it with a shop cloth.
- When removing (disengaging) components with a screwdriver or similar tool, be sure to wrap the component with a shop cloth or vinyl tape to protect it.
- Protect the removed parts with a shop cloth and prevent them from being dropped.
- Replace a deformed or damaged clip.
- If a part is specified as a non-reusable part, always replace it with a new one.
- Be sure to tighten bolts and nuts securely to the specified torque.
- After installation is complete, be sure to check that each part works properly.
- Follow the steps below to clean components:
 - Water soluble dirt:
 - Dip a soft cloth into lukewarm water, wring the water out of the cloth and wipe the dirty area.
 - Then rub with a soft, dry cloth.
 - Oily dirt:

A

B

C

D

E

F

G

H

I

J

EXT

L

M

N

O

P

PRECAUTIONS

< PRECAUTION >

- Dip a soft cloth into lukewarm water with mild detergent (concentration: within 2 to 3%) and wipe the dirty area.
- Then dip a cloth into fresh water, wring the water out of the cloth and wipe the detergent off.
- Then rub with a soft, dry cloth.
- Do not use organic solvent such as thinner, benzene, alcohol or gasoline.
- For genuine leather seats, use a genuine leather seat cleaner.

PREPARATION

< PREPARATION >

PREPARATION

PREPARATION

Special Service Tool

INFOID:000000010249322

The actual shape of the tools may differ from those illustrated here.

Tool number (TechMate No.) Tool name	Description
— (J-39570) Chassis Ear	Locating the noise
— (J-50397) NISSAN Squeak and Rattle Kit	Repairing the cause of noise
— (J-46534) Trim Tool Set	Removing trim components

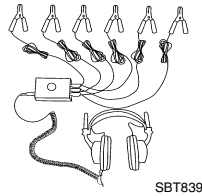

SBT839



ALJIA1232ZZ

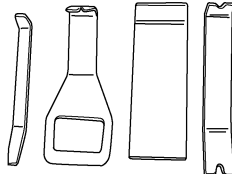

AWJIA0483ZZ

Commercial Service Tool

INFOID:000000010249323

(TechMate No.) Tool name	Description
(J-39565) Engine Ear	Locating the noise

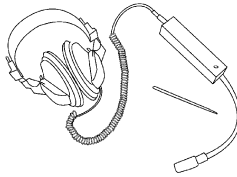

SIIA0995E

A
B
C
D
E
F
G
H
I
J
EXT
L
M
N
O
P

CLIP LIST







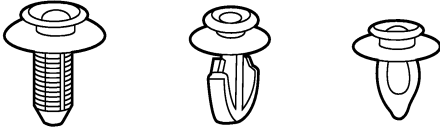

< PREPARATION >

CLIP LIST

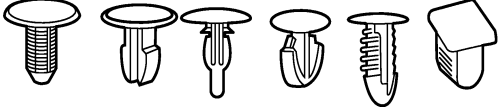
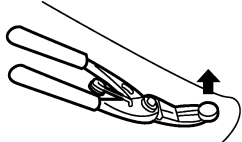
Descriptions for Clips

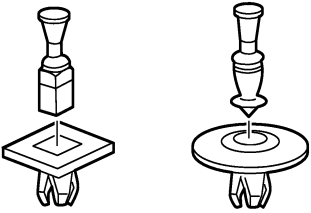
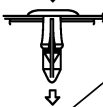
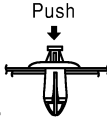
INFOID:000000010249324

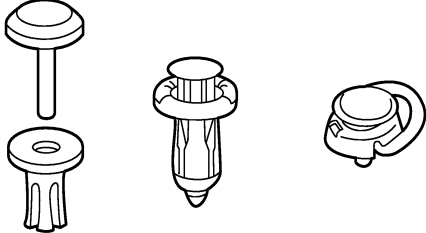
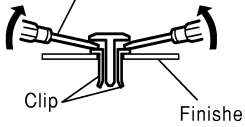

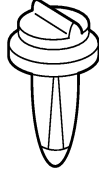
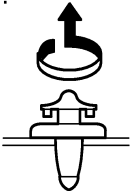





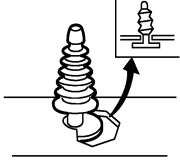
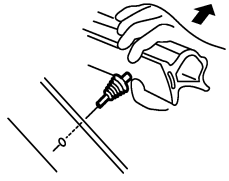

Replace any clips which are damaged during removal or installation.

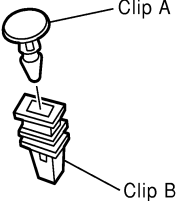
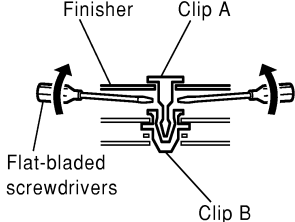
Symbol No.	Shapes	Removal & Installation
C101 		<p>Removal: Remove by bending up with flat-bladed screwdrivers or clip remover.</p> 
C103 		 <p>Removal: Remove with a clip remover.</p>
C203 		<p>Removal: Push center pin to catching position. (Do not remove center pin by hitting it.)</p> <p>Push</p>  <p>Installation:</p> <p>Push</p> 
C205 		<p>Removal:</p>  <p>Flat-bladed screwdriver</p> <p>Clip</p> <p>Finisher</p>
C206 		<p>Removal:</p> 

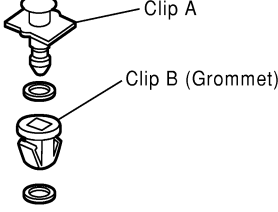
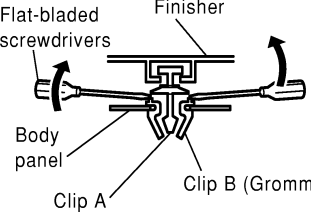
SIIA0315E

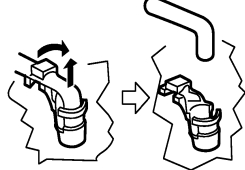
CLIP LIST

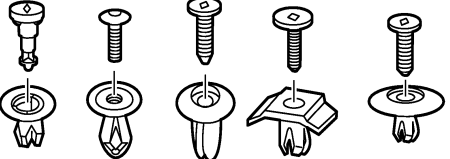
< PREPARATION >









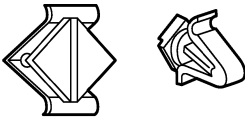

Symbol No.	Shapes	Removal & Installation
<p>CE103</p> 		<p>Removal:</p> 
<p>CF110</p> 		<p>Removal:</p> 
<p>CF118</p> 		<p>Removal:</p> 
<p>CR103</p> 		<p>Removal: Holder portion of clip must be spread out to remove rod.</p> 
<p>CS101</p> 		<p>Removal:</p> <ol style="list-style-type: none"> 1. Screw out with a Phillips screwdriver. 2. Remove female portion with flat-bladed screwdriver. 

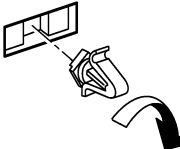
SIIA0316E

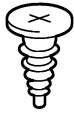
A
B
C
D
E
F
G
H
I
J
EXT
L
M
N
O
P

CLIP LIST

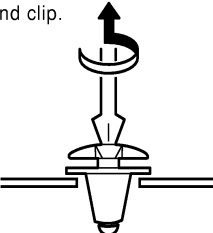

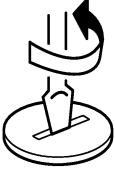
< PREPARATION >

Symbol No.	Shapes	Removal & Installation	
CG101 		Removal:  Rotate 45° to remove	Installation: 
CS102 			
CS113 		Removal: Disconnect upper connection of clip with a flat-bladed screwdriver, then remove clip while inserting a flat-bladed screwdriver between body panel and clip. 	
C111 			

SIIA0317E

CLIP LIST

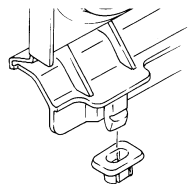
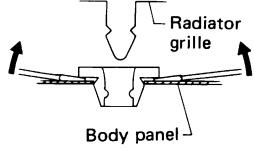
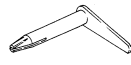
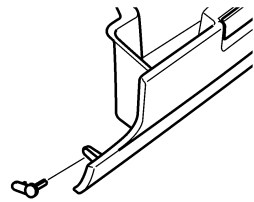
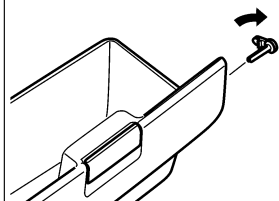
< PREPARATION >

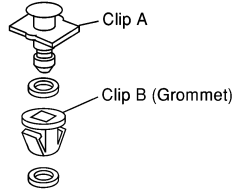
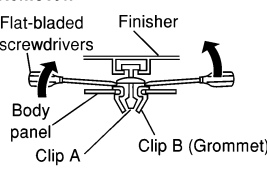
Symbol No.	Shapes	Removal & Installation
<p>CG104</p> 		<p>Removal: Remove by bending up with flat-bladed screwdrivers.</p> 
<p>CE114</p> 		
<p>CF118</p> 		<p>Removal: Flat-bladed screwdrivers</p> 

ALJIA0564GB

A
B
C
D
E
F
G
H
I
J
L
M
N
O
P

EXT

SQUEAK AND RATTLE TROUBLE DIAGNOSES

< SYMPTOM DIAGNOSIS >

SYMPTOM DIAGNOSIS

SQUEAK AND RATTLE TROUBLE DIAGNOSES

Work Flow

INFOID:000000010249314

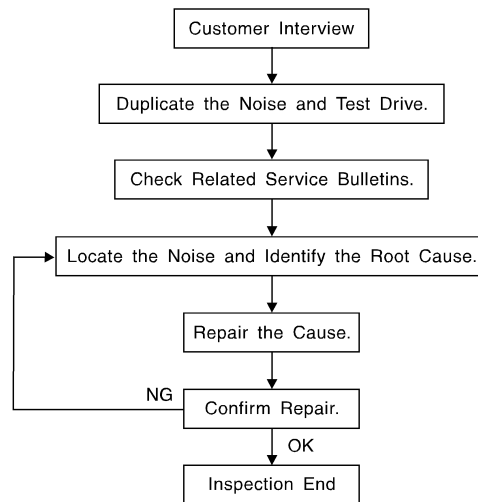

SBT842

CUSTOMER INTERVIEW

Interview the customer if possible, to determine the conditions that exist when the noise occurs. Use the Diagnostic Worksheet during the interview to document the facts and conditions when the noise occurs and any customer's comments; refer to [EXT-14, "Diagnostic Worksheet"](#). This information is necessary to duplicate the conditions that exist when the noise occurs.

- The customer may not be able to provide a detailed description or the location of the noise. Attempt to obtain all the facts and conditions that exist when the noise occurs (or does not occur).
- If there is more than one noise in the vehicle, be sure to diagnose and repair the noise that the customer is concerned about. This can be accomplished by test driving the vehicle with the customer.
- After identifying the type of noise, isolate the noise in terms of its characteristics. The noise characteristics are provided so the customer, service adviser and technician are all speaking the same language when defining the noise.
- Squeak —(Like tennis shoes on a clean floor)
Squeak characteristics include the light contact/fast movement/brought on by road conditions/hard surfaces = higher pitch noise/softer surfaces = lower pitch noises/edge to surface = chirping.
- Creak—(Like walking on an old wooden floor)
Creak characteristics include firm contact/slow movement/twisting with a rotational movement/pitch dependent on materials/often brought on by activity.
- Rattle—(Like shaking a baby rattle)
Rattle characteristics include the fast repeated contact/vibration or similar movement/loose parts/missing clip or fastener/incorrect clearance.
- Knock —(Like a knock on a door)
Knock characteristics include hollow sounding/sometimes repeating/often brought on by driver action.
- Tick—(Like a clock second hand)
Tick characteristics include gentle contacting of light materials/loose components/can be caused by driver action or road conditions.
- Thump—(Heavy, muffled knock noise)
Thump characteristics include softer knock/dead sound often brought on by activity.
- Buzz—(Like a bumble bee)
Buzz characteristics include high frequency rattle/firm contact.
- Often the degree of acceptable noise level will vary depending upon the person. A noise that you may judge as acceptable may be very irritating to the customer.
- Weather conditions, especially humidity and temperature, may have a great effect on noise level.

DUPLICATE THE NOISE AND TEST DRIVE

SQUEAK AND RATTLE TROUBLE DIAGNOSES

< SYMPTOM DIAGNOSIS >

If possible, drive the vehicle with the customer until the noise is duplicated. Note any additional information on the Diagnostic Worksheet regarding the conditions or location of the noise. This information can be used to duplicate the same conditions when you confirm the repair.

If the noise can be duplicated easily during the test drive, to help identify the source of the noise, try to duplicate the noise with the vehicle stopped by doing one or all of the following:

- 1) Close a door.
 - 2) Tap or push/pull around the area where the noise appears to be coming from.
 - 3) Rev the engine.
 - 4) Use a floor jack to recreate vehicle "twist".
 - 5) At idle, apply engine load (electrical load, half-clutch on M/T model, drive position on CVT and A/T models).
 - 6) Raise the vehicle on a hoist and hit a tire with a rubber hammer.
- Drive the vehicle and attempt to duplicate the conditions the customer states exist when the noise occurs.
 - If it is difficult to duplicate the noise, drive the vehicle slowly on an undulating or rough road to stress the vehicle body.

CHECK RELATED SERVICE BULLETINS

After verifying the customer concern or symptom, check ASIST for Technical Service Bulletins (TSBs) related to that concern or symptom.

If a TSB relates to the symptom, follow the procedure to repair the noise.

LOCATE THE NOISE AND IDENTIFY THE ROOT CAUSE

1. Narrow down the noise to a general area. To help pinpoint the source of the noise, use a listening tool (Chassis Ear: J-39570, Engine Ear: J-39565 and mechanic's stethoscope).
2. Narrow down the noise to a more specific area and identify the cause of the noise by:
 - removing the components in the area that you suspect the noise is coming from.
Do not use too much force when removing clips and fasteners, otherwise clips and fasteners can be broken or lost during the repair, resulting in the creation of new noise.
 - tapping or pushing/pulling the component that you suspect is causing the noise.
Do not tap or push/pull the component with excessive force, otherwise the noise will be eliminated only temporarily.
 - feeling for a vibration with your hand by touching the component(s) that you suspect is (are) causing the noise.
 - placing a piece of paper between components that you suspect are causing the noise.
 - looking for loose components and contact marks.Refer to [EXT-11. "Generic Squeak and Rattle Troubleshooting"](#).

REPAIR THE CAUSE

- If the cause is a loose component, tighten the component securely.
- If the cause is insufficient clearance between components:
 - separate components by repositioning or loosening and retightening the component, if possible.
 - insulate components with a suitable insulator such as urethane pads, foam blocks, felt cloth tape or urethane tape. A NISSAN Squeak and Rattle Kit (J-50397) is available through your authorized NISSAN Parts Department.

CAUTION:

Do not use excessive force as many components are constructed of plastic and may be damaged.

NOTE:

- Always check with the Parts Department for the latest parts information.
- The materials contained in the NISSAN Squeak and Rattle Kit (J-50397) are listed on the inside cover of the kit; and can each be ordered separately as needed.
- The following materials not found in the kit can also be used to repair squeaks and rattles.
 - SILICONE GREASE: Use instead of UHMW tape that will be visible or does not fit. The silicone grease will only last a few months.
 - SILICONE SPRAY: Use when grease cannot be applied.
 - DUCT TAPE: Use to eliminate movement.

CONFIRM THE REPAIR

Confirm that the cause of a noise is repaired by test driving the vehicle. Operate the vehicle under the same conditions as when the noise originally occurred. Refer to the notes on the Diagnostic Worksheet.

Generic Squeak and Rattle Troubleshooting

INFOID:000000010249315

Refer to Table of Contents for specific component removal and installation information.

SQUEAK AND RATTLE TROUBLE DIAGNOSES

< SYMPTOM DIAGNOSIS >

INSTRUMENT PANEL

Most incidents are caused by contact and movement between:

1. Cluster lid A and the instrument panel
2. Acrylic lens and combination meter housing
3. Instrument panel to front pillar finisher
4. Instrument panel to windshield
5. Instrument panel pins
6. Wiring harnesses behind the combination meter
7. A/C defroster duct and duct joint

These incidents can usually be located by tapping or moving the components to duplicate the noise or by pressing on the components while driving to stop the noise. Most of these incidents can be repaired by applying felt cloth tape or silicone spray (in hard to reach areas). Urethane pads can be used to insulate wiring harness.

CAUTION:

Do not use silicone spray to isolate a squeak or rattle. If you saturate the area with silicone, you will not be able to recheck the repair.

CENTER CONSOLE

Components to pay attention to include:

1. Shift selector assembly cover to finisher
2. A/C control unit and cluster lid C
3. Wiring harnesses behind audio and A/C control unit

The instrument panel repair and isolation procedures also apply to the center console.

DOORS

Pay attention to the:

1. Finisher and inner panel making a slapping noise
2. Inside handle escutcheon to door finisher
3. Wiring harnesses tapping
4. Door striker out of alignment causing a popping noise on starts and stops

Tapping or moving the components or pressing on them while driving to duplicate the conditions can isolate many of these incidents. You can usually insulate the areas with felt cloth tape or insulator foam blocks from the NISSAN Squeak and Rattle Kit (J-50397) to repair the noise.

TRUNK

Trunk noises are often caused by a loose jack or loose items put into the trunk by the owner.

In addition look for:

1. Trunk lid bumpers out of adjustment
2. Trunk lid striker out of adjustment
3. The trunk lid torsion bars knocking together
4. A loose license plate or bracket

Most of these incidents can be repaired by adjusting, securing or insulating the item(s) or component(s) causing the noise.

SUNROOF/HEADLINING

Noises in the sunroof/headlining area can often be traced to one of the following:

1. Sunroof lid, rail, linkage or seals making a rattle or light knocking noise
2. Sun visor shaft shaking in the holder
3. Front or rear windshield touching headlining and squeaking

Again, pressing on the components to stop the noise while duplicating the conditions can isolate most of these incidents. Repairs usually consist of insulating with felt cloth tape.

OVERHEAD CONSOLE (FRONT AND REAR)

Overhead console noises are often caused by the console panel clips not being engaged correctly. Most of these incidents are repaired by pushing up on the console at the clip locations until the clips engage.

In addition look for:

SQUEAK AND RATTLE TROUBLE DIAGNOSES

< SYMPTOM DIAGNOSIS >

1. Loose harness or harness connectors.
2. Front console map/reading lamp lens loose.
3. Loose screws at console attachment points.

A

SEATS

When isolating seat noise it's important to note the position the seat is in and the load placed on the seat when the noise is present. These conditions should be duplicated when verifying and isolating the cause of the noise.

B

Cause of seat noise include:

C

1. Headrest rods and holder
2. A squeak between the seat pad cushion and frame
3. The rear seatback lock and bracket

D

These noises can be isolated by moving or pressing on the suspected components while duplicating the conditions under which the noise occurs. Most of these incidents can be repaired by repositioning the component or applying urethane tape to the contact area.

E

UNDERHOOD

Some interior noise may be caused by components under the hood or on the engine wall. The noise is then transmitted into the passenger compartment.

F

Causes of transmitted underhood noise include:

1. Any component installed to the engine wall
2. Components that pass through the engine wall
3. Engine wall mounts and connectors
4. Loose radiator installation pins
5. Hood bumpers out of adjustment
6. Hood striker out of adjustment

G

H

These noises can be difficult to isolate since they cannot be reached from the interior of the vehicle. The best method is to secure, move or insulate one component at a time and test drive the vehicle. Also, engine rpm or load can be changed to isolate the noise. Repairs can usually be made by moving, adjusting, securing, or insulating the component causing the noise.

I

J

EXT

L

M

N

O

P

SQUEAK AND RATTLE TROUBLE DIAGNOSES

< SYMPTOM DIAGNOSIS >

Diagnostic Worksheet

INFOID:000000010249316

Dear Customer:

We are concerned about your satisfaction with your vehicle. Repairing a squeak or rattle sometimes can be very difficult. To help us fix your vehicle right the first time, please take a moment to note the area of the vehicle where the squeak or rattle occurs and under what conditions. You may be asked to take a test drive with a service advisor or technician to ensure we confirm the noise you are hearing.

SQUEAK & RATTLE DIAGNOSTIC WORKSHEET

I. WHERE DOES THE NOISE COME FROM? (circle the area of the vehicle)

The illustrations are for reference only, and may not reflect the actual configuration of your vehicle.



Continue to page 2 of the worksheet and briefly describe the location of the noise or rattle. In addition, please indicate the conditions which are present when the noise occurs.

SQUEAK AND RATTLE TROUBLE DIAGNOSES

< SYMPTOM DIAGNOSIS >

SQUEAK & RATTLE DIAGNOSTIC WORKSHEET - page 2

Briefly describe the location where the noise occurs:

II. WHEN DOES IT OCCUR? (please check the boxes that apply)

- | | |
|---|--|
| <input type="checkbox"/> Anytime | <input type="checkbox"/> After sitting out in the rain |
| <input type="checkbox"/> 1st time in the morning | <input type="checkbox"/> When it is raining or wet |
| <input type="checkbox"/> Only when it is cold outside | <input type="checkbox"/> Dry or dusty conditions |
| <input type="checkbox"/> Only when it is hot outside | <input type="checkbox"/> Other: |

III. WHEN DRIVING:

- Through driveways
- Over rough roads
- Over speed bumps
- Only about ____ mph
- On acceleration
- Coming to a stop
- On turns: left, right or either (circle)
- With passengers or cargo
- Other: _____
- After driving ____ miles or ____ minutes

IV. WHAT TYPE OF NOISE

- Squeak (like tennis shoes on a clean floor)
- Creak (like walking on an old wooden floor)
- Rattle (like shaking a baby rattle)
- Knock (like a knock at the door)
- Tick (like a clock second hand)
- Thump (heavy muffled knock noise)
- Buzz (like a bumble bee)

TO BE COMPLETED BY DEALERSHIP PERSONNEL

Test Drive Notes:

	YES	NO	Initials of person performing
Vehicle test driven with customer	<input type="checkbox"/>	<input type="checkbox"/>	_____
- Noise verified on test drive	<input type="checkbox"/>	<input type="checkbox"/>	_____
- Noise source located and repaired	<input type="checkbox"/>	<input type="checkbox"/>	_____
- Follow up test drive performed to confirm repair	<input type="checkbox"/>	<input type="checkbox"/>	_____

VIN: _____ Customer Name _____

W.O.# _____ Date: _____

This form must be attached to Work Order

LAI/A0071E

A
B
C
D
E
F
G
H
I
J
L
M
N
O
P

EXT

FRONT BUMPER

< REMOVAL AND INSTALLATION >

REMOVAL AND INSTALLATION

FRONT BUMPER

Exploded View

INFOID:000000009795091

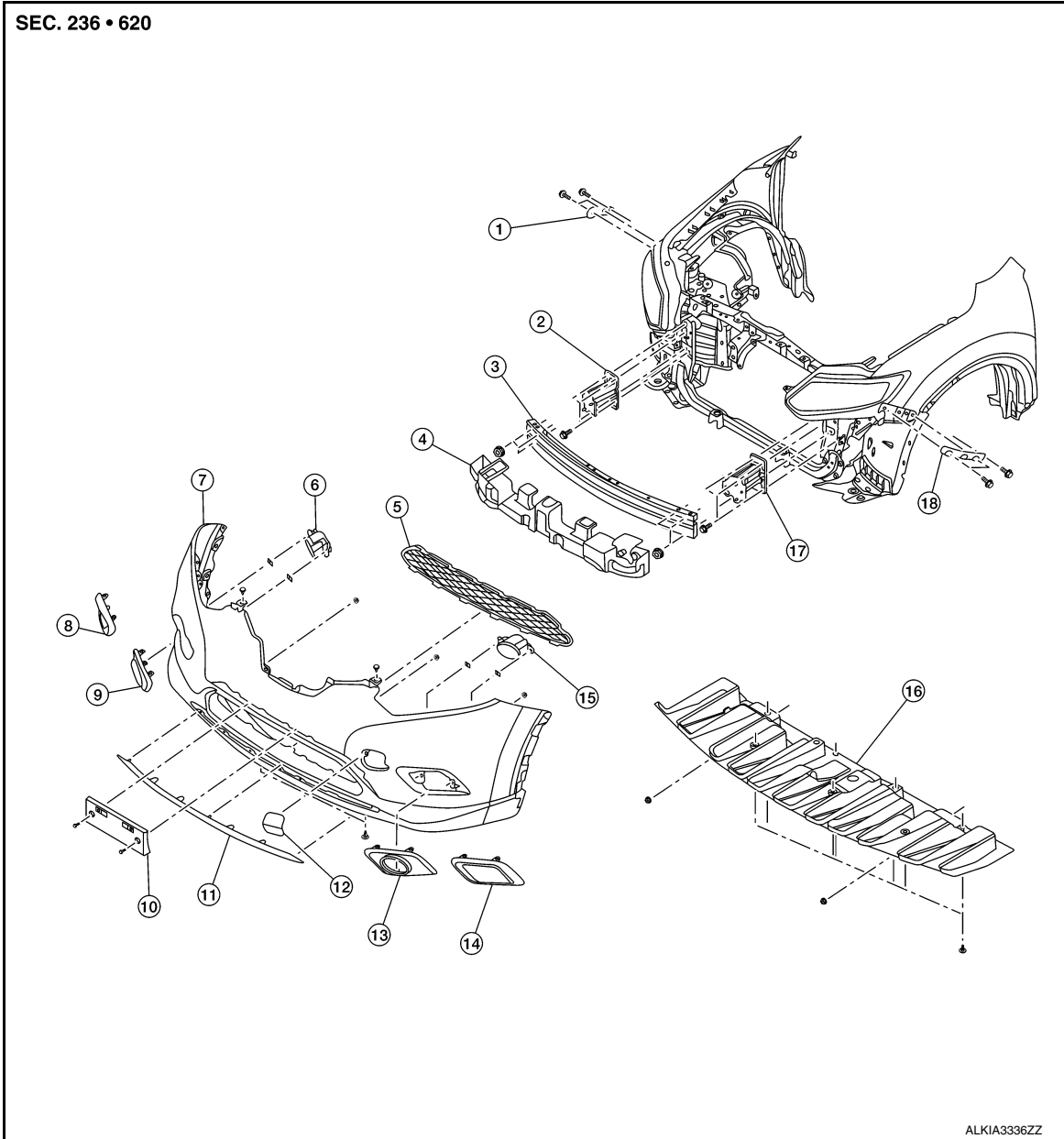

- | | | |
|--|---|---|
| 1. Front bumper fascia side bracket (RH) | 2. Front bumper reinforcement support (RH) | 3. Front bumper reinforcement |
| 4. Front energy absorber | 5. Front lower grille | 6. Front fog lamp (RH) (if equipped) |
| 7. Front bumper fascia | 8. Front bumper fascia finisher (RH) (if equipped) | 9. Front fog lamp finisher (RH) (if equipped) |
| 10. Front license plate bracket | 11. Front air spoiler | 12. Tow cover |
| 13. Front fog lamp finisher (LH) (if equipped) | 14. Front bumper fascia finisher (LH) (if equipped) | 15. Front fog lamp (LH) (if equipped) |
| 16. Front under cover | 17. Front bumper reinforcement support (LH) | 18. Front bumper fascia side bracket (LH) |

FRONT BUMPER

< REMOVAL AND INSTALLATION >

Removal and Installation

INFOID:000000009795092

REMOVAL

CAUTION:

Bumper fascia is made of resin. Use care when handling to prevent damage. Avoid contact with oily substances.

1. Remove front grille. Refer to [EXT-23. "Removal and Installation"](#).
2. Remove front bumper fascia clips (A).

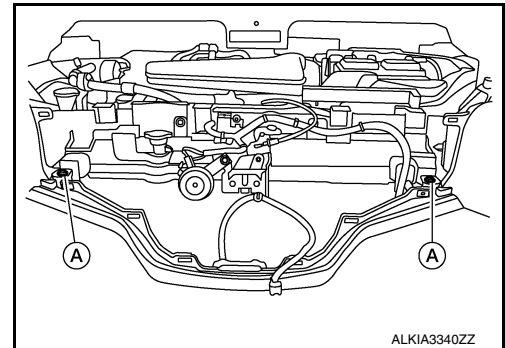

3. Remove front bumper fascia clips (A) and screws (B).

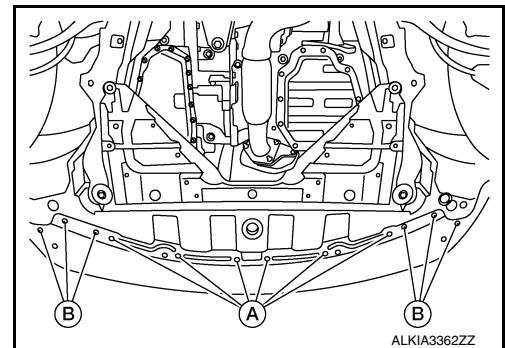

4. Partially remove front fender protectors (LH/RH). Refer to [EXT-28. "FENDER PROTECTOR : Exploded View"](#).
5. Partially remove front over fender molding. Refer to [EXT-30. "FRONT OVER FENDER : Removal and Installation"](#).
6. Remove front bumper fascia screws (A) (LH/RH).
(1): Front bumper fascia
(2): Front over fender molding

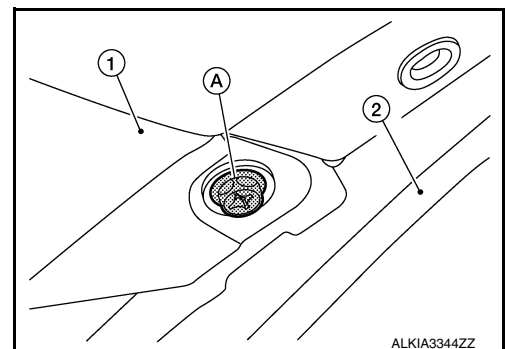

7. Disconnect fog lamp harness connectors (LH/RH) (if equipped).
8. Release front bumper fascia pawls from front bumper fascia side brackets (LH/RH) and remove.

CAUTION:

When removing front bumper fascia, two people are required to avoid damaging.

FRONT BUMPER

< REMOVAL AND INSTALLATION >

9. Remove front bumper fascia bolts (A) and the front bumper side bracket (1) (LH/RH) (if necessary).

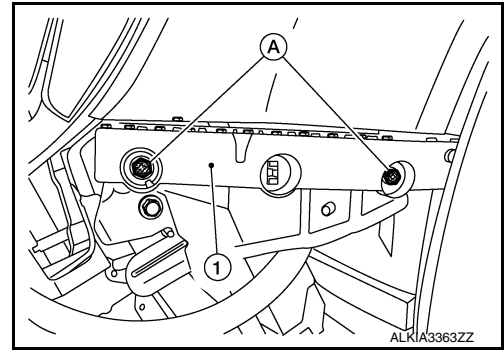

10. Remove intelligent key warning buzzer. Refer to [DLK-273, "Removal and Installation"](#).
11. Release harness connector clips from bumper reinforcement, then remove bumper reinforcement nuts (A) and bumper reinforcement (1) (LH/RH).

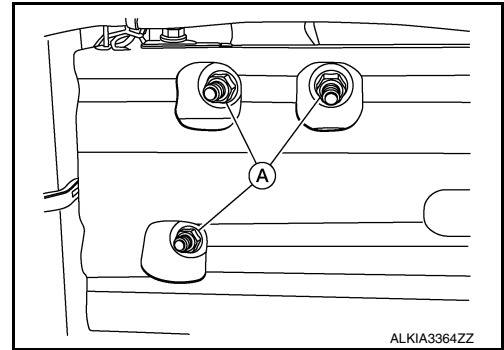

12. Remove front bumper reinforcement support bolts (A) and front bumper reinforcement supports (1) (LH/RH).

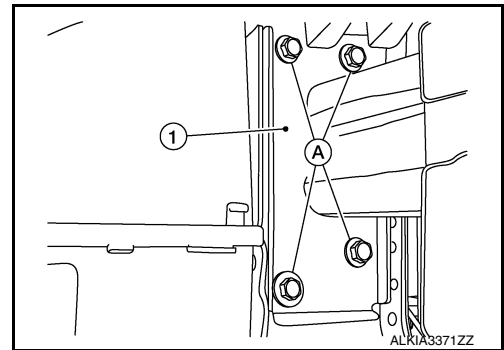

13. Remove the following parts (if necessary) after removing front bumper fascia assembly.
- Front fog lamps (if equipped). Refer to [EXL-121, "Removal and Installation"](#).
 - Front fog lamp finishers
 - Front fascia grille
 - Front license plate bracket

INSTALLATION

Installation in the reverse order of removal.

- The following table shows the specified values for checking normal installation status.

FRONT BUMPER

< REMOVAL AND INSTALLATION >

- Fitting adjustment cannot be performed.

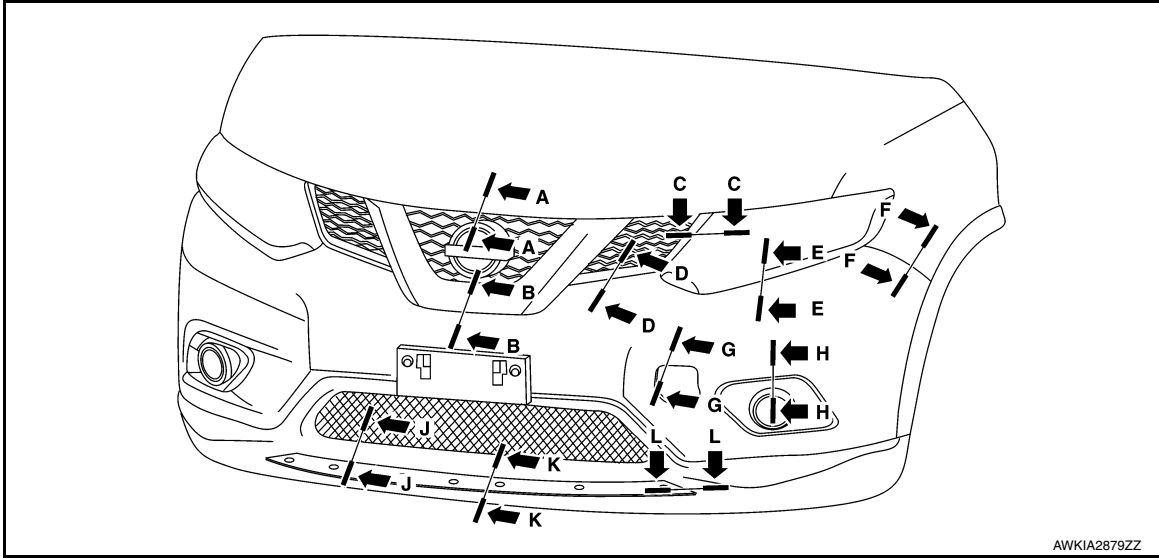

mm (in)

Section	Measurement	Minimum	Target Value	Maximum
A-A	Clearance	6.9 (0.27)	8.9 (0.35)	10.9 (0.43)
B-B	Clearance	0.1 (0.004)	1.5 (0.06)	3.0 (0.12)
C-C	Clearance	0.0 (0.00)	0.0 (0.00)	0.0 (0.00)
D-D	Clearance	0.1 (0.004)	1.5 (0.06)	3.0 (0.12)
E-E	Clearance	0.1 (0.004)	1.5 (0.06)	3.0 (0.12)
F-F	Clearance	0.1 (0.004)	0.3 (0.01)	1.0 (0.04)
F-F	Surface height	-0.3 (0.01)	0.7 (0.03)	1.7 (0.07)
G-G	Clearance	0.0 (0.00)	0.5 (0.02)	1.0 (0.04)
G-G	Surface height	0.0 (0.00)	0.5 (0.02)	1.0 (0.04)
H-H	Clearance	0.5 (0.02)	1.5 (0.06)	2.5 (0.10)
J-J	Clearance	0.0 (0.00)	1.0 (0.04)	2.0 (0.08)
K-K	Clearance	0.0 (0.00)	1.0 (0.04)	2.0 (0.08)
K-K	Surface height	0.0 (0.00)	1.0 (0.04)	2.0 (0.08)
L-L	Clearance	0.5 (0.02)	2.0 (0.08)	3.5 (0.14)
L-L	Surface height	0.0 (0.00)	1.0 (0.04)	2.0 (0.08)

REAR BUMPER

< REMOVAL AND INSTALLATION >

REAR BUMPER

Exploded View

INFOID:000000009795093

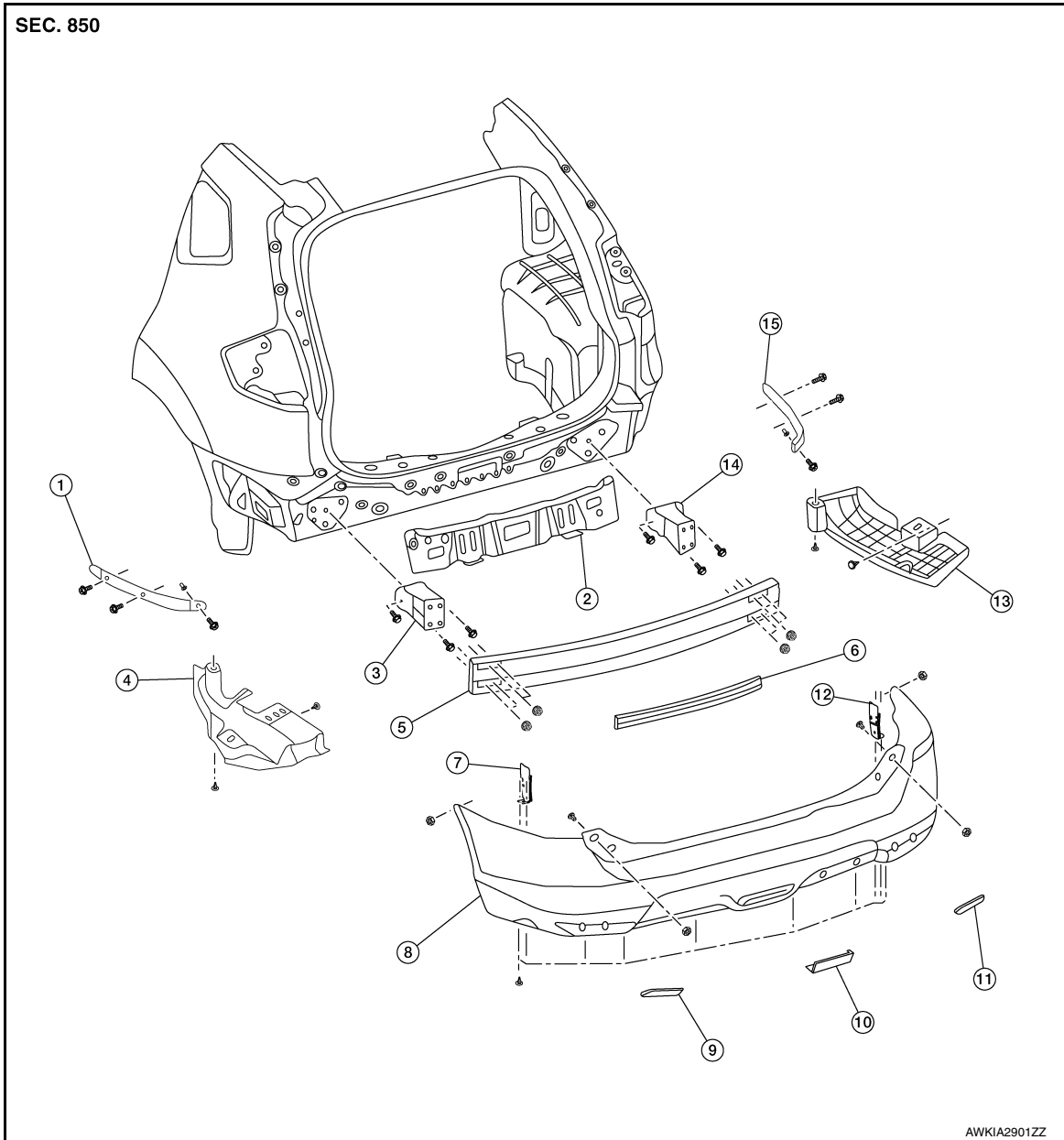

- | | | |
|---|--|---|
| 1. Rear bumper fascia side bracket (LH) | 2. Rear mud protector | 3. Rear bumper reinforcement support (LH) |
| 4. Rear bumper fascia undercover (LH) | 5. Rear bumper reinforcement | 6. Rear energy absorber |
| 7. Rear bumper bracket (LH) | 8. Rear bumper fascia | 9. Rear bumper fascia reflector (LH) |
| 10. Rear bumper finisher | 11. Rear bumper fascia reflector (RH) | 12. Rear bumper bracket (RH) |
| 13. Rear bumper fascia undercover (RH) | 14. Rear bumper reinforcement support (RH) | 15. Rear bumper fascia side bracket (RH) |

Removal and Installation

INFOID:000000009795094

REMOVAL

Revision: November 2013

EXT-20

2014 Rogue NAM

REAR BUMPER

< REMOVAL AND INSTALLATION >

CAUTION:

Bumper fascia is made of resin. Use care when handling to prevent damage. Avoid contact with oily substances.

1. Partially remove rear over fender molding. Refer to [EXT-32, "REAR OVER FENDER : Exploded View"](#).
2. Partially remove rear wheel house protector. Refer to [EXT-29, "REAR WHEEL HOUSE PROTECTOR : Removal and Installation"](#).
3. Remove clips and remove rear bumper fascia undercover (LH/RH) then remove rear mud guard (LH/RH). Refer to [EXT-34, "Removal and Installation"](#).
4. Remove rear bumper fascia upper screws (A).

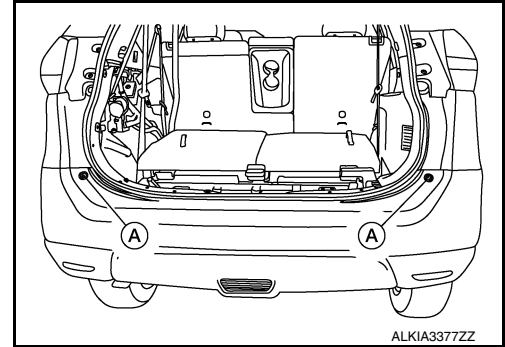

5. Remove rear bumper fascia screw (A) (LH/RH).

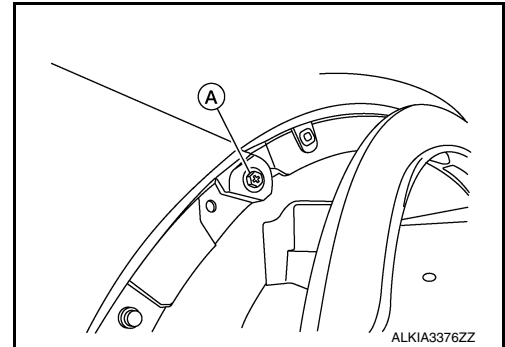

6. Disconnect harness connector from rear sonar sensors (if equipped).
7. Release pawls (LH/RH) using a suitable tool and remove rear bumper fascia.

○: Pawl

CAUTION:

When removing rear bumper fascia, two people are required to avoid damaging.

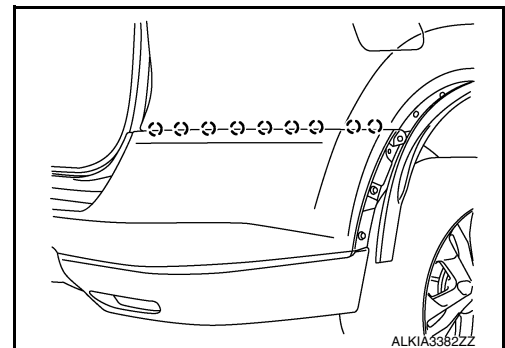

8. Remove energy absorber.
9. Remove bolts (A) and remove rear bumper side bracket (LH/RH) (if necessary).

REAR BUMPER

< REMOVAL AND INSTALLATION >

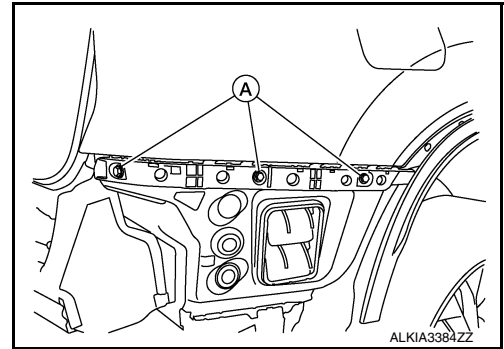

10. Remove rear bumper reinforcement nuts (LH/RH), then remove rear bumper reinforcement (if necessary).
11. Remove bumper stay bolts, then remove bumper stay (if necessary).
12. Remove rear bump reinforce support bolts and rear bumper reinforcement (LH/RH).

INSTALLATION

Installation is in the reverse order of removal.

NOTE:

- The following table shows the specified values for checking normal installation status.
- Fitting adjustment cannot be performed.

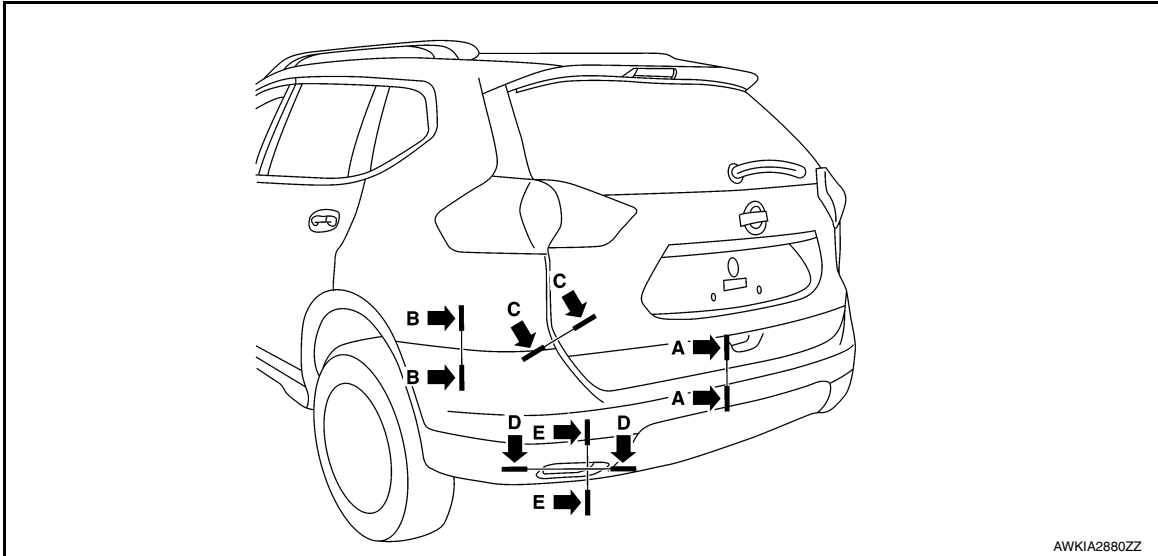

Unit: mm (in)

Section	Measurement	Minimum	Target Value	Maximum
A-A	Clearance	6.0 (0.24)	8.0 (0.31)	10.0 (0.39)
B-B	Clearance	0.1 (0.004)	0.3 (0.04)	1.0 (0.04)
B-B	Surface height	-0.3 (0.01)	0.7 (0.06)	1.7 (0.07)
C-C	Clearance	3.0 (0.12)	5.0 (0.20)	7.0 (0.28)
C-C	Surface height	-2.2 (-0.09)	0.3 (0.00)	2.4 (0.09)
D-D	Clearance	0.0 (0.00)	1.0 (0.04)	2.0 (0.08)
E-E	Clearance	0.6 (0.02)	1.6 (0.04)	2.6 (0.10)
E-E	Clearance	0.0 (0.00)	1.0 (0.04)	2.0 (0.08)

FRONT GRILLE

< REMOVAL AND INSTALLATION >

FRONT GRILLE

Exploded View

INFOID:000000009795095

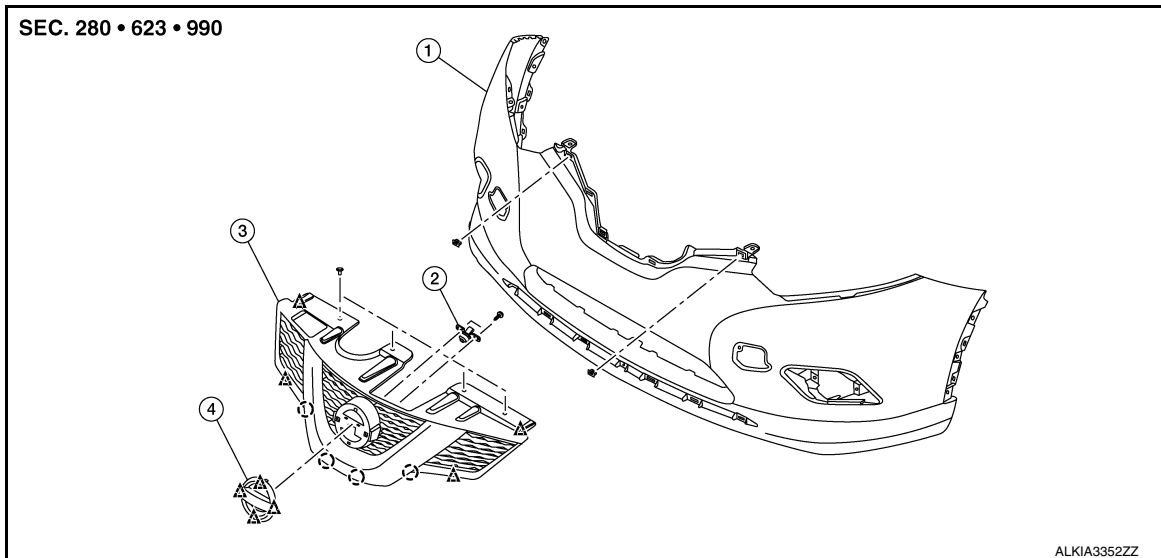

- 1. Front bumper fascia
 - 2. Front camera (if equipped)
 - 3. Front grille
 - 4. Front emblem
- Pawl △ Clip

Removal and Installation

INFOID:000000009795096

REMOVAL

1. Remove front grille upper clip (A) (LH/RH).

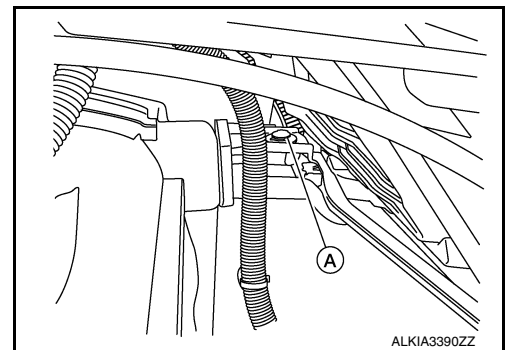

2. Release clips and pawls, then remove front grille.

- △ Clip
- Pawl

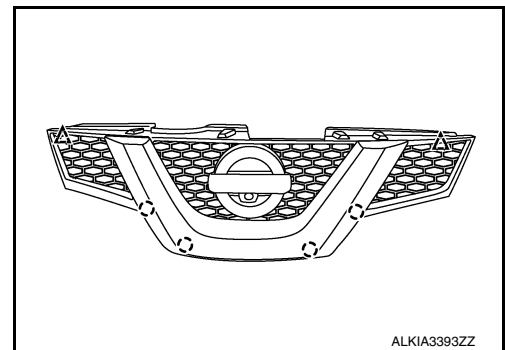

A
B
C
D
E
F
G
H
I
J
EXT
L
M
N
O
P

FRONT GRILLE

< REMOVAL AND INSTALLATION >

3. Disconnect harness connector (A) from front camera (if equipped).

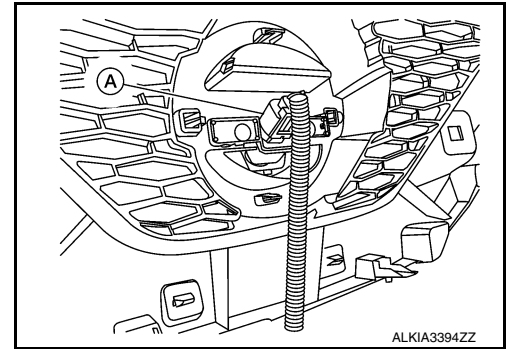

4. Remove the following parts after removing front grille (if necessary).
 - Front camera (if equipped). Refer to [AV-388, "Removal and Installation"](#).
 - Front emblem

INSTALLATION

Installation is in the reverse order of removal.

NOTE:

Calibration must be performed after removing/replacing the front camera (if equipped). Refer to [AV-292, "CALIBRATING CAMERA IMAGE \(AROUND VIEW MONITOR\) : Work Procedure"](#).

COWL TOP

< REMOVAL AND INSTALLATION >

COWL TOP

Exploded View

INFOID:000000009795097

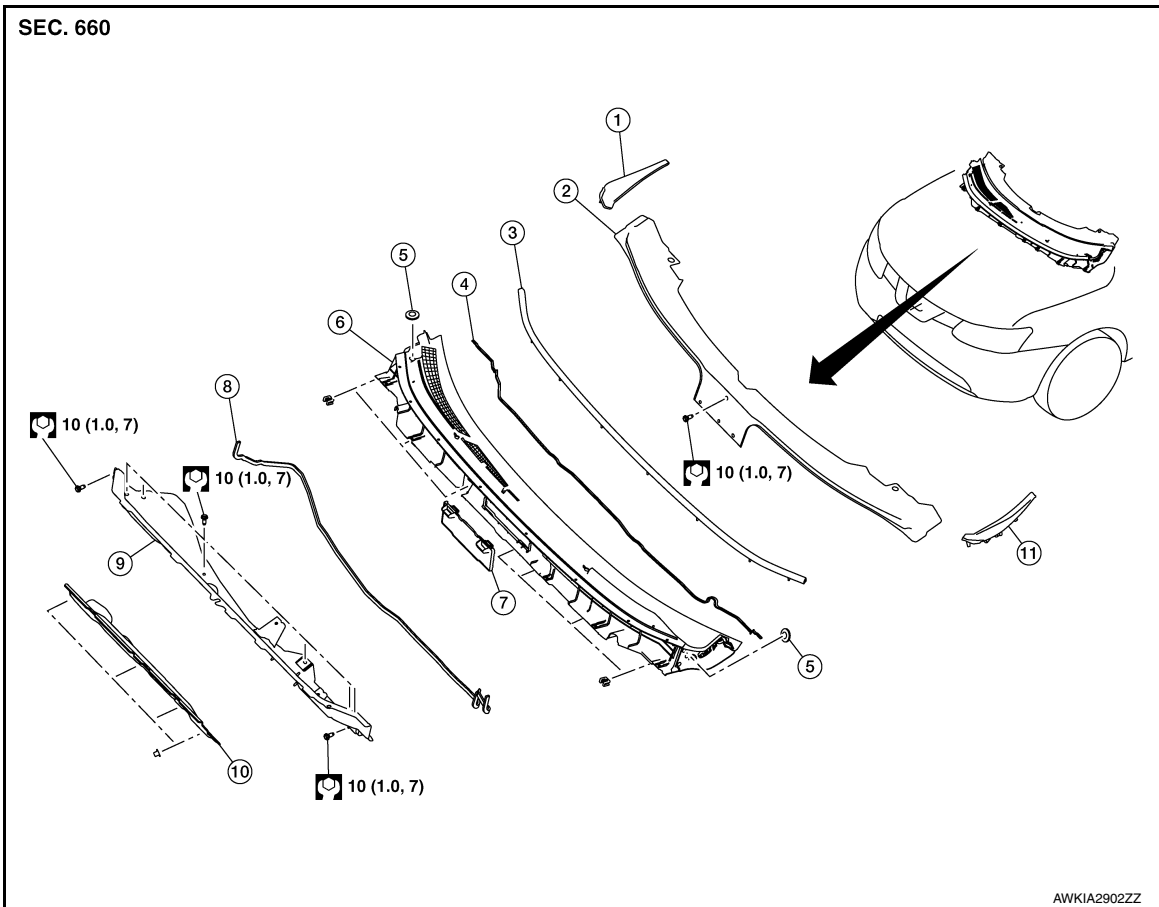

- | | | |
|----------------------------------|-----------------------------------|------------------------|
| 1. Cowl top side trim cover (RH) | 2. Cowl top cover screen | 3. Cowl top cover seal |
| 4. EPT seal | 5. Cowl top cover plug | 6. Cowl top cover |
| 7. Cowl top cover mask | 8. Cowl top extension seal | 9. Cowl top extension |
| 10. Cowl top insulation | 11. Cowl top side trim cover (LH) | |

Removal and Installation

INFOID:000000009795098

COWL TOP COVER

Removal

1. Remove front wiper arms (LH/RH). Refer to [WW-63. "Removal and Installation"](#).
2. Release pawls using suitable tool (A) and remove cowl top side trim cover (1) (LH/RH).

○: Pawl

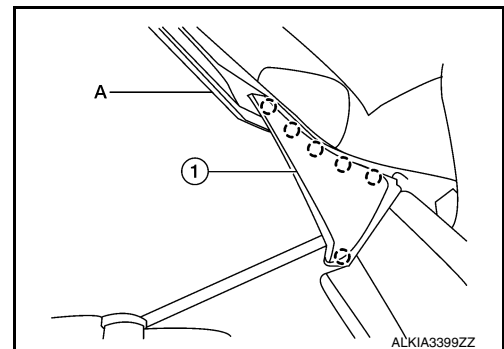

A
B
C
D
E
F
G
H
I
J
EXT
L
M
N
O
P

COWL TOP

< REMOVAL AND INSTALLATION >

3. Disconnect front washer tube connector.

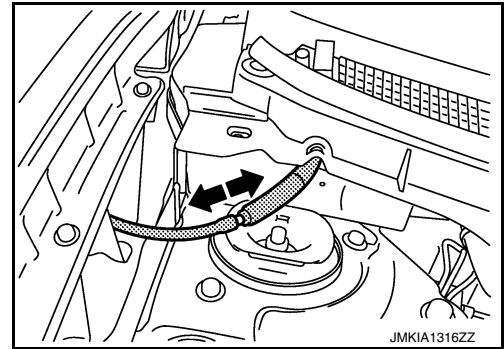

4. Remove cowl top cover clips, then pull forward to release cowl top cover and remove.

CAUTION:

When performing the procedure after removing cowl top cover, cover the lower end of windshield glass with urethane etc.

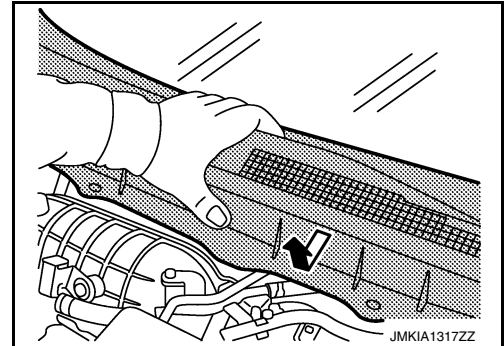

5. Remove the following parts after removing cowl top cover (if necessary).
 - Cowl top seal
 - Cowl top cover plug
 - Washer nozzle, Refer to [WW-60, "Removal and Installation - Front Washer Nozzle"](#).
 - Washer tube, [WW-60, "Removal and Installation - Front Washer Nozzle"](#).
 - EPT sealer

Installation

Installation is in the reverse order of removal.

CAUTION:

When installing cowl top cover, check that clips are securely fitted in body panel holes and then press them in.

COWL TOP EXTENSION

Removal

1. Remove the front wiper drive assembly. Refer to [WW-66, "Removal and Installation"](#).
2. Remove the cowl top extension bolts and the cowl top extension.

INSTALLATION

Installation is in the reverse order of removal.

CAUTION:

When installing cowl top cover, check that clips are securely placed in panel holes on body and then pressed in.

NOTE:

COWL TOP

< REMOVAL AND INSTALLATION >

When installing the cowl top extension, tighten the bolts to specification in the order shown.

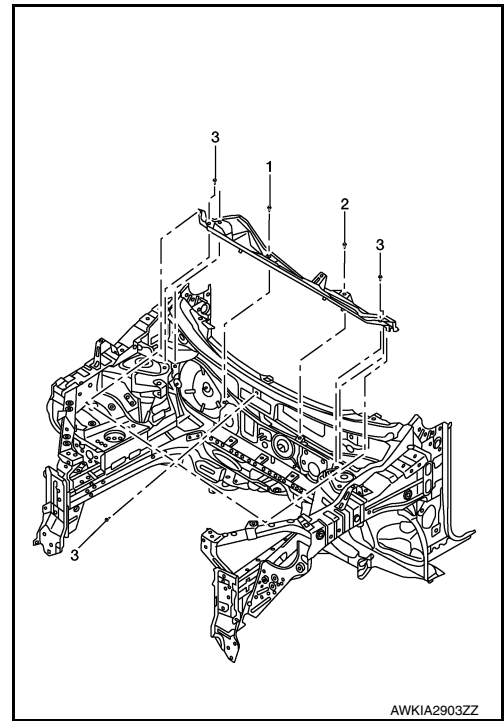

A
B
C
D
E
F
G
H
I
J
L
M
N
O
P

EXT

FENDER PROTECTOR

< REMOVAL AND INSTALLATION >

FENDER PROTECTOR

FENDER PROTECTOR

FENDER PROTECTOR : Exploded View

INFOID:000000010249307

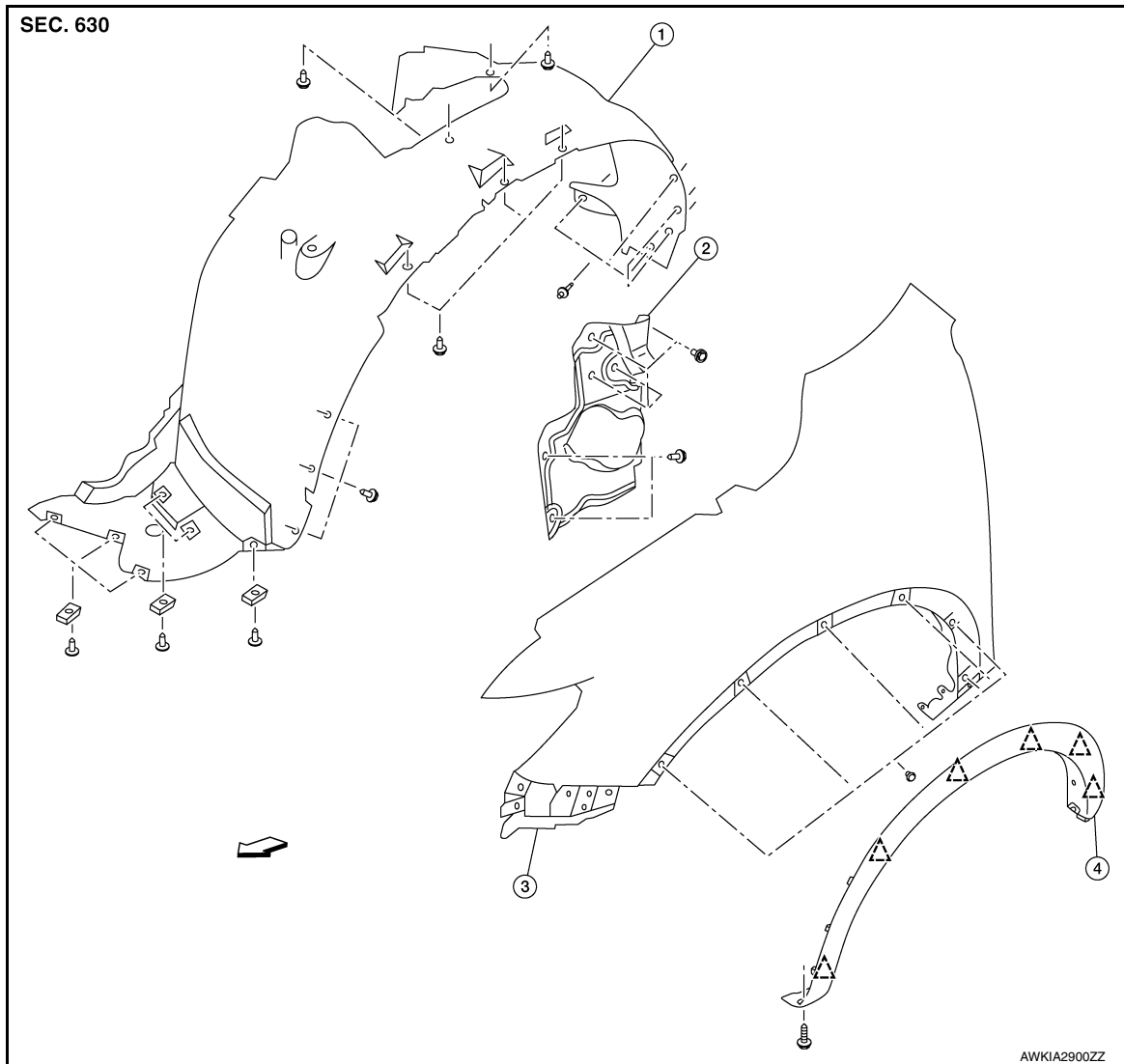

- 1. Front fender protector
- 4. Over fender

- 2. Engine side cover
- △ Clip

- 3. Front fender
- ⇐ Front

FENDER PROTECTOR : Removal and Installation

INFOID:000000010249308

REMOVAL

1. Remove wheel and tire using power tool. Refer to [WT-60, "Removal and Installation"](#).
2. Remove front over fender molding. Refer to [EXT-30, "FRONT OVER FENDER : Removal and Installation"](#).
3. Remove front under cover. Refer to [EXT-16, "Exploded View"](#).
4. Remove sill molding screw. Refer to [EXT-35, "Exploded View - Center Mudguard"](#).
5. Remove engine side cover.
6. Release front fender protector clips and remove front fender protector.

INSTALLATION

Installation is in the reverse order of removal.

FENDER PROTECTOR

< REMOVAL AND INSTALLATION >

REAR WHEEL HOUSE PROTECTOR

REAR WHEEL HOUSE PROTECTOR : Exploded View

INFOID:000000010249309

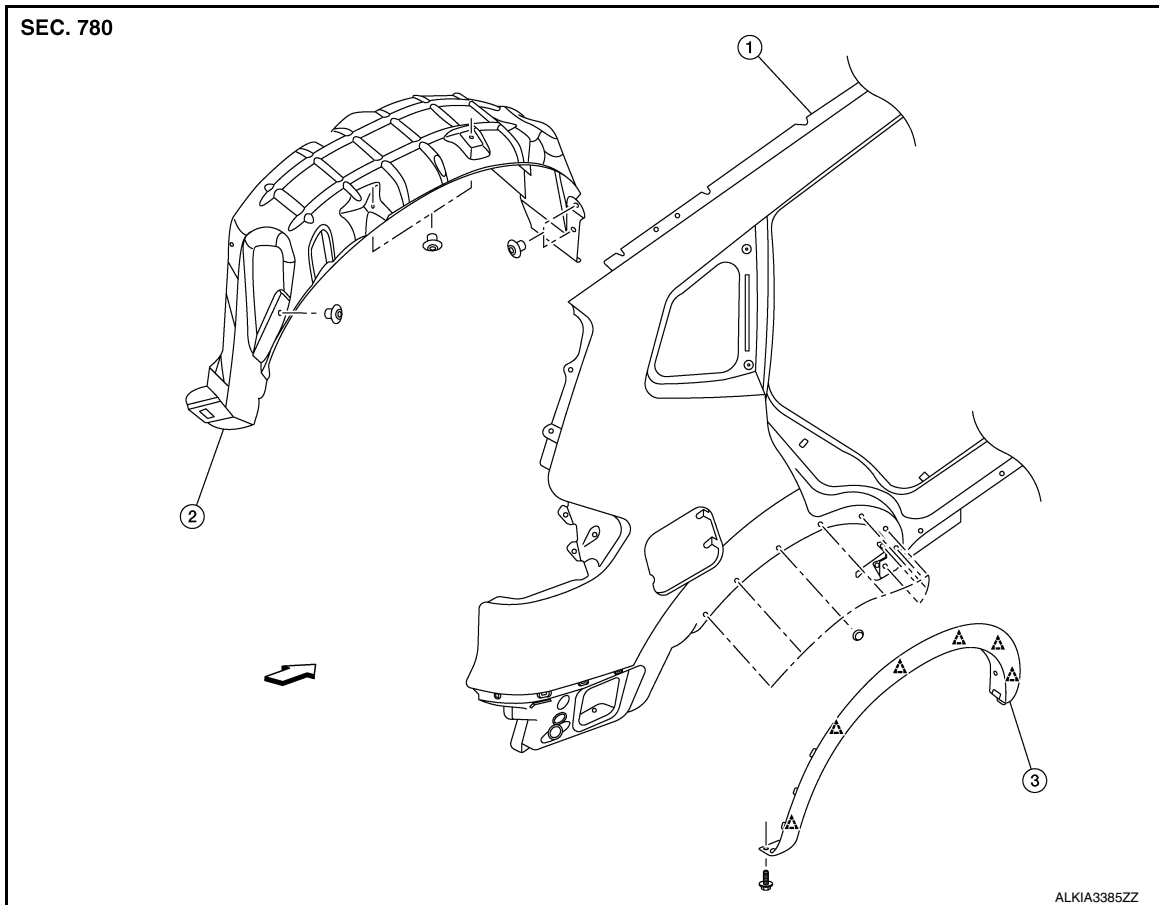

1. Rear fender

2. Rear wheel house protector

3. rear over fender molding

△ Clip

← Front

REAR WHEEL HOUSE PROTECTOR : Removal and Installation

INFOID:000000010249310

REMOVAL

1. Remove rear wheel house protector clip and screws.
2. Remove rear wheel house protector nuts and rear wheel house protector.

INSTALLATION

Installation is in the reverse order of removal.

OVER FENDER

< REMOVAL AND INSTALLATION >

OVER FENDER

FRONT OVER FENDER

FRONT OVER FENDER : Exploded View

INFOID:000000010250287

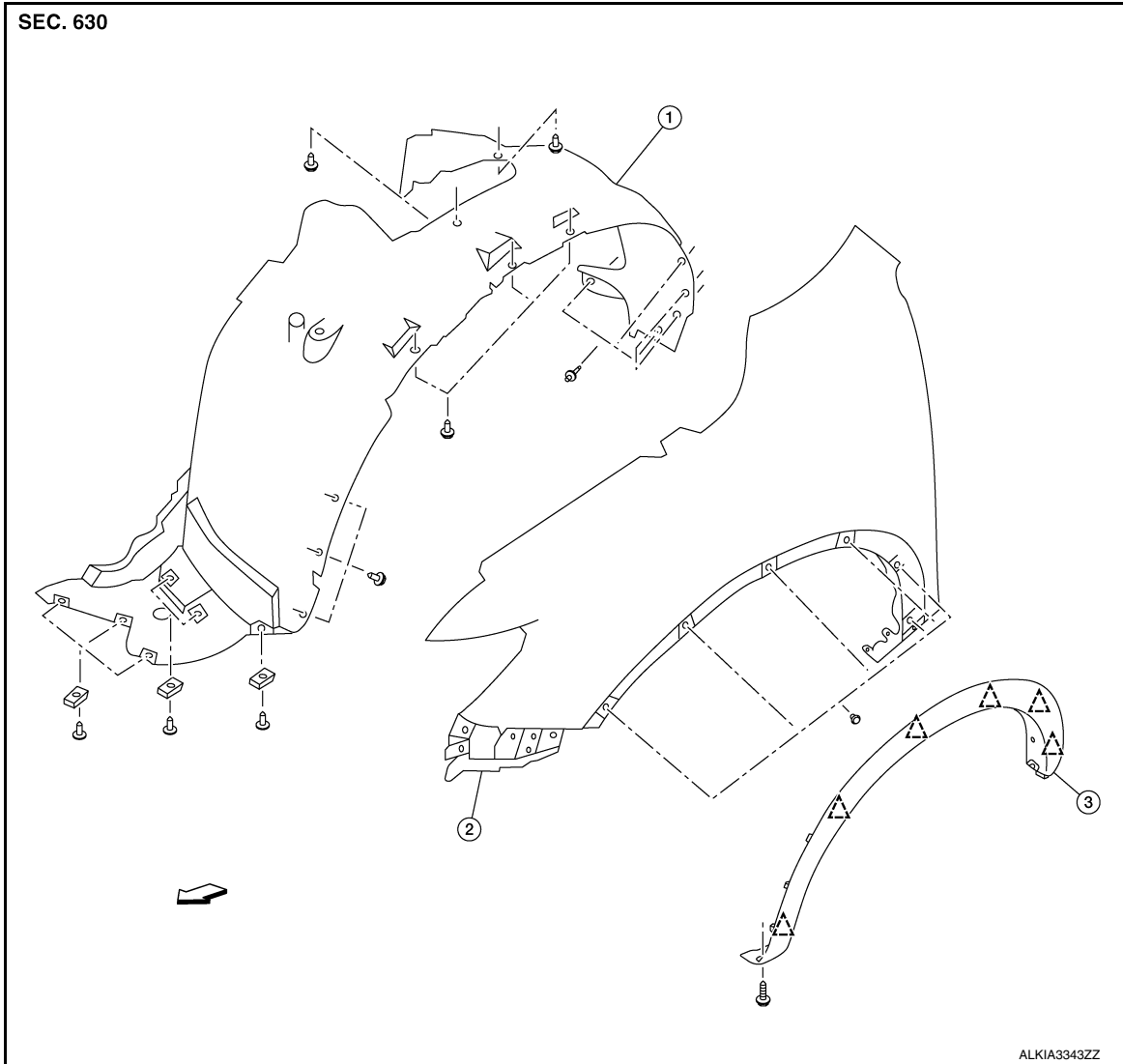

1. Front fender protector

2. Front fender

3. Front over fender molding

△ Clip

FRONT OVER FENDER : Removal and Installation

INFOID:000000010250288

REMOVAL

OVER FENDER

< REMOVAL AND INSTALLATION >

1. Remove front and rear screw (A).
1: Front over fender
2: Sill molding
⇐: Front

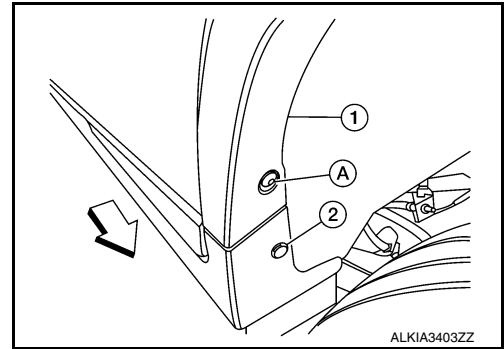

2. Release clips using suitable tool (A) and remove front over fender (1).
△: Clips

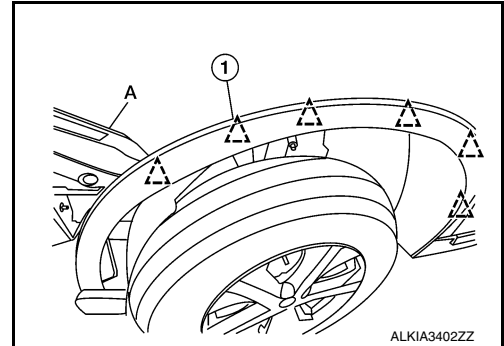

INSTALLATION

Installation is in the reverse order of removal.

CAUTION:

- Visually check the clips for deformation and damage during installation. Replace with new ones if necessary.
- When installing front over fender molding, check that clips are securely placed in body panel holes.

REAR OVER FENDER

A
B
C
D
E
F
G
H
I
J
L
M
N
O
P

EXT

OVER FENDER

< REMOVAL AND INSTALLATION >

REAR OVER FENDER : Exploded View

INFOID:000000010262930

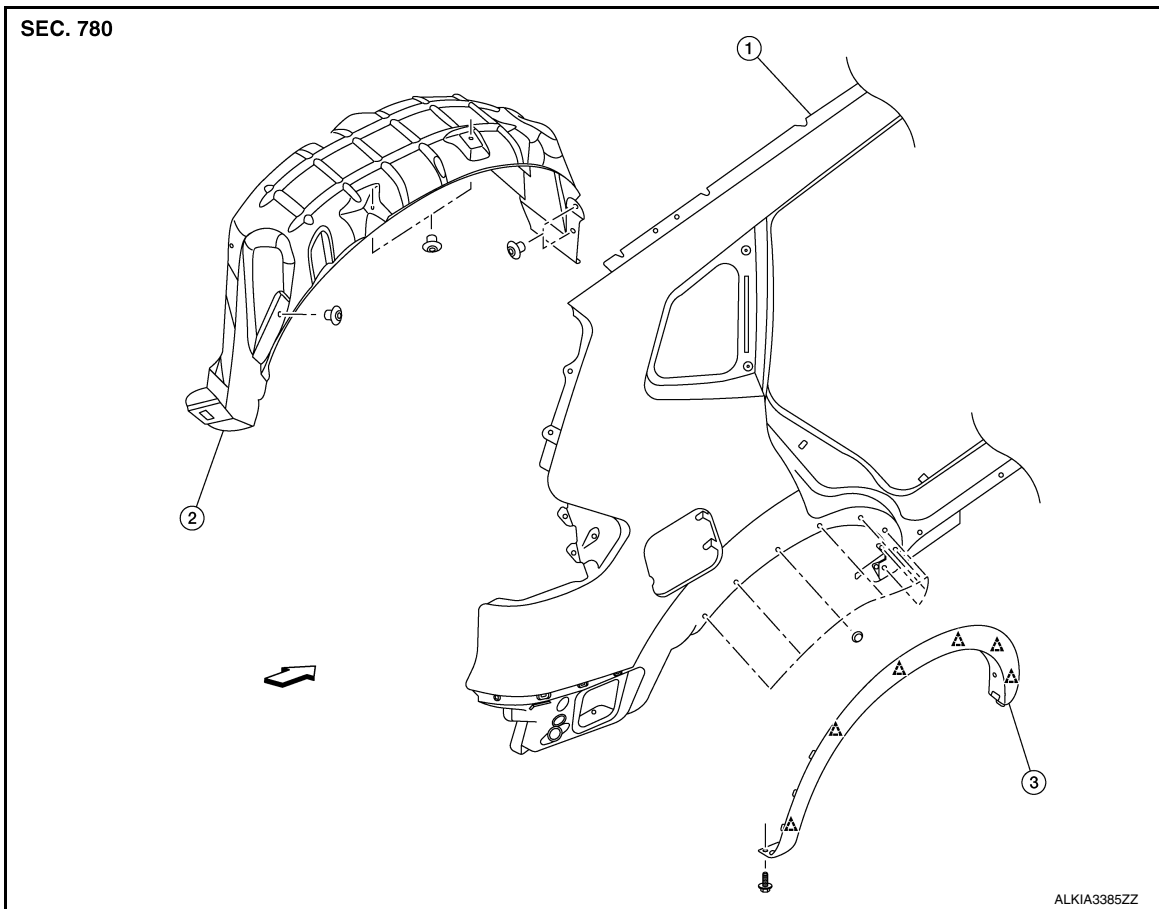

1. Rear fender

2. Rear wheel house protector

3. Rear over fender molding

△ Clip

⇐ Front

REAR OVER FENDER : Removal and Installation

INFOID:000000010262931

REMOVAL

1. Remove rear over fender molding screws (A).

1: Rear over fender

2: Rear bumper

⇐ Front

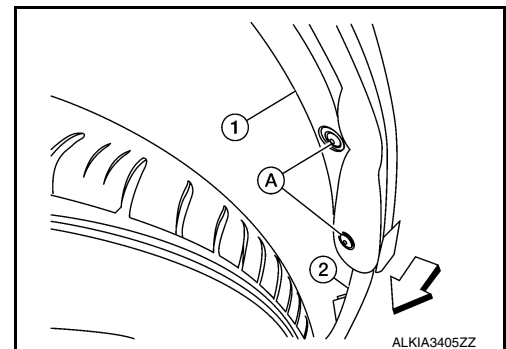

OVER FENDER

< REMOVAL AND INSTALLATION >

2. Release clips using suitable tool (A) and remove rear over fender (1).

△: Clips

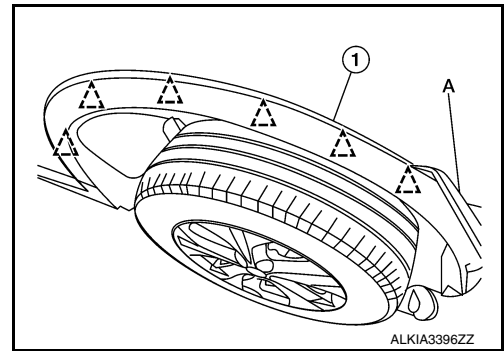

INSTALLATION

Installation is in the reverse order of removal.

CAUTION:

- Visually check the clips for deformation and damage during installation. Replace with new ones if necessary.
- When installing over fender molding, check that clips are securely placed in body panel holes.

A
B
C
D
E
F
G
H
I
J
L
M
N
O
P

EXT

MUDGUARD

< REMOVAL AND INSTALLATION >

MUDGUARD

Exploded View

INFOID:000000009795101

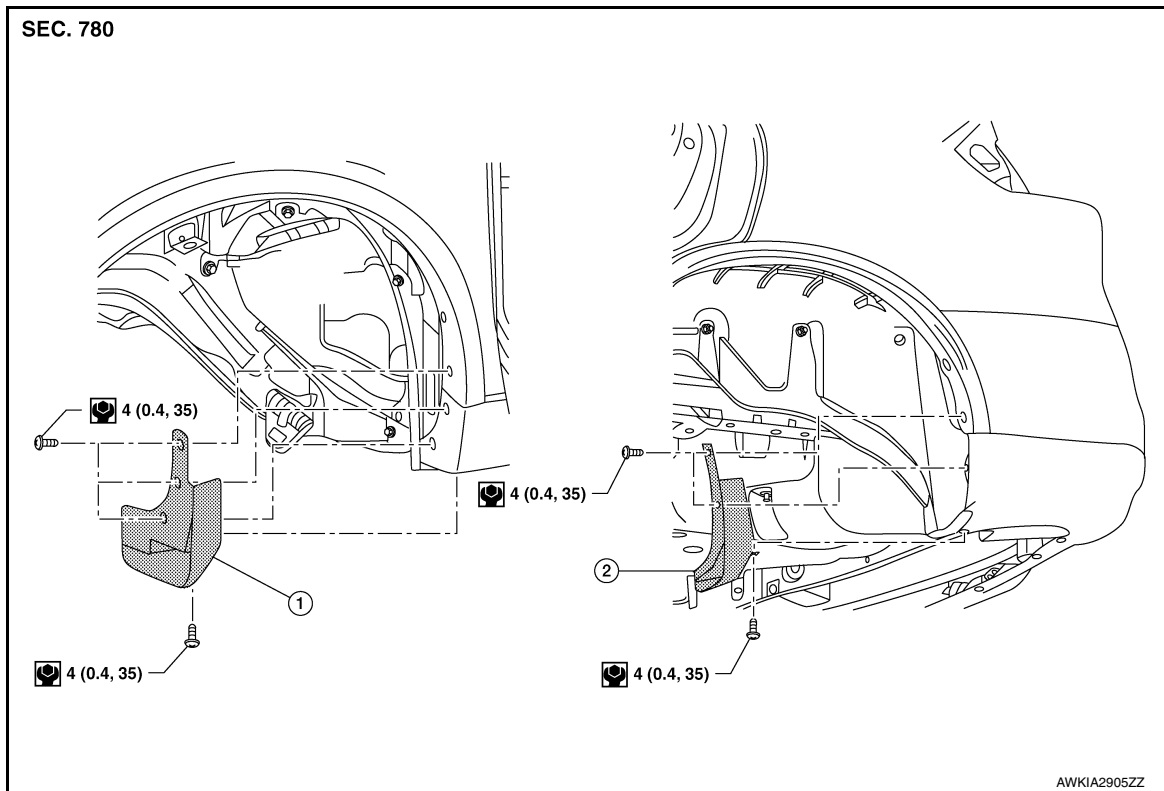

1. Front mud guard

2. Rear mud guard

Removal and Installation

INFOID:000000009795102

FRONT MUD GUARD

Removal

Remove front mud guard screws and remove front mud guard.

Installation

Installation is in the reverse order of removal.

REAR MUD GUARD

Removal

Remove rear mud guard screws and remove rear mud guard.

Installation

Installation is in the reverse order of removal.

MUDGUARD

< REMOVAL AND INSTALLATION >

Exploded View - Center Mudguard

INFOID:000000010249320

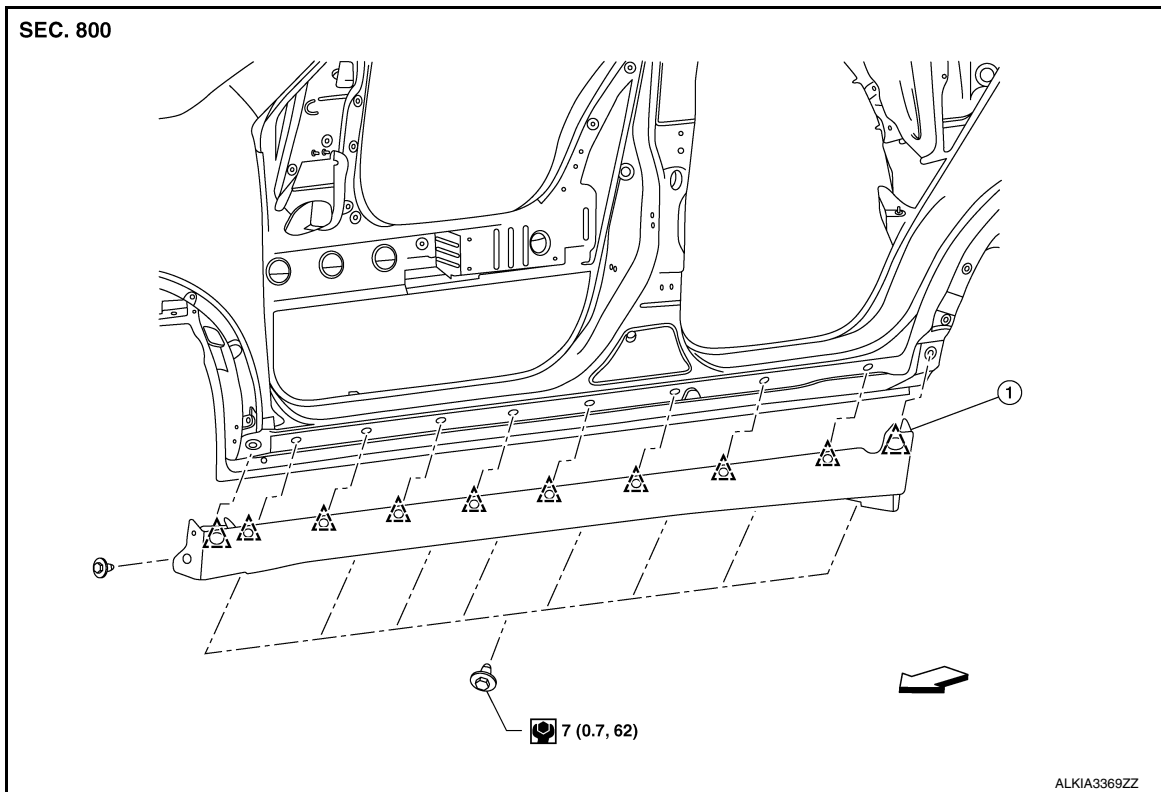

1. Center mudguard

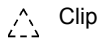

Clip

← Front

Removal and Installation - Center Mudguard

INFOID:000000010249321

REMOVAL

1. Partially remove over fender moldings. Refer to [EXT-30, "FRONT OVER FENDER : Exploded View"](#).
2. Remove screws (A) from center mudguard (1).

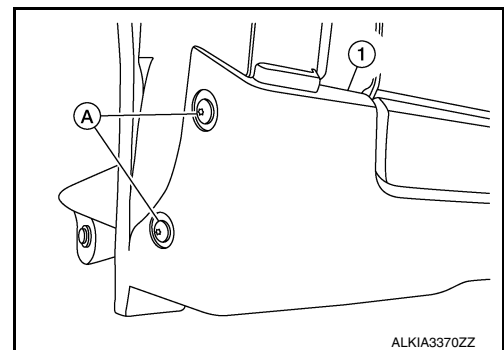

3. Remove center mudguard center mudguard bolts (A) from center mudguard (1).

MUDGUARD

< REMOVAL AND INSTALLATION >

↔: Front

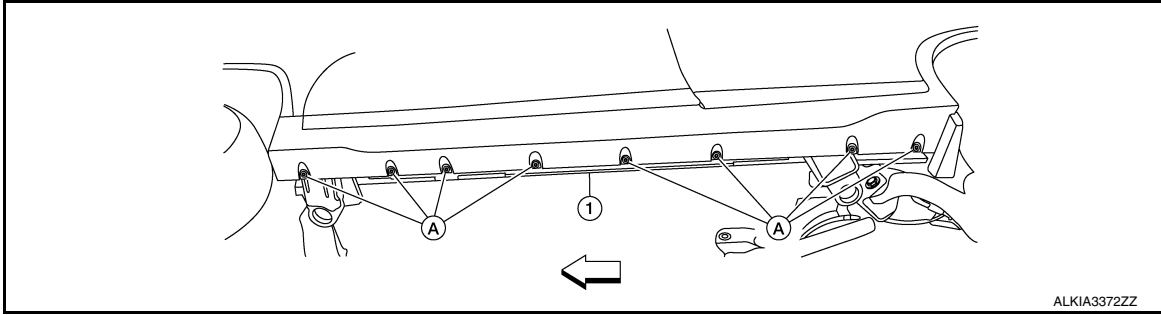

4. Release center mudguard clips with a suitable tool (A) and remove the center mudguard (1).

△: Clip

CAUTION:

Release clips slowly and carefully.

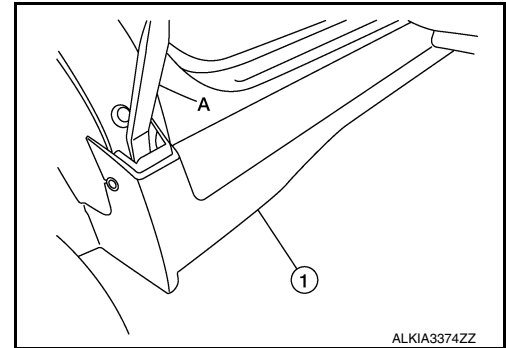

INSTALLATION

Installation is in the reverse order of removal.

CAUTION:

- **Visually check the clips for deformation and damage during installation. Replace with new ones if necessary.**
- **When installing center mudguard, check that clips are securely placed in body panel holes.**

UNDER COVER

< REMOVAL AND INSTALLATION >

UNDER COVER

Exploded View

INFOID:000000009795103

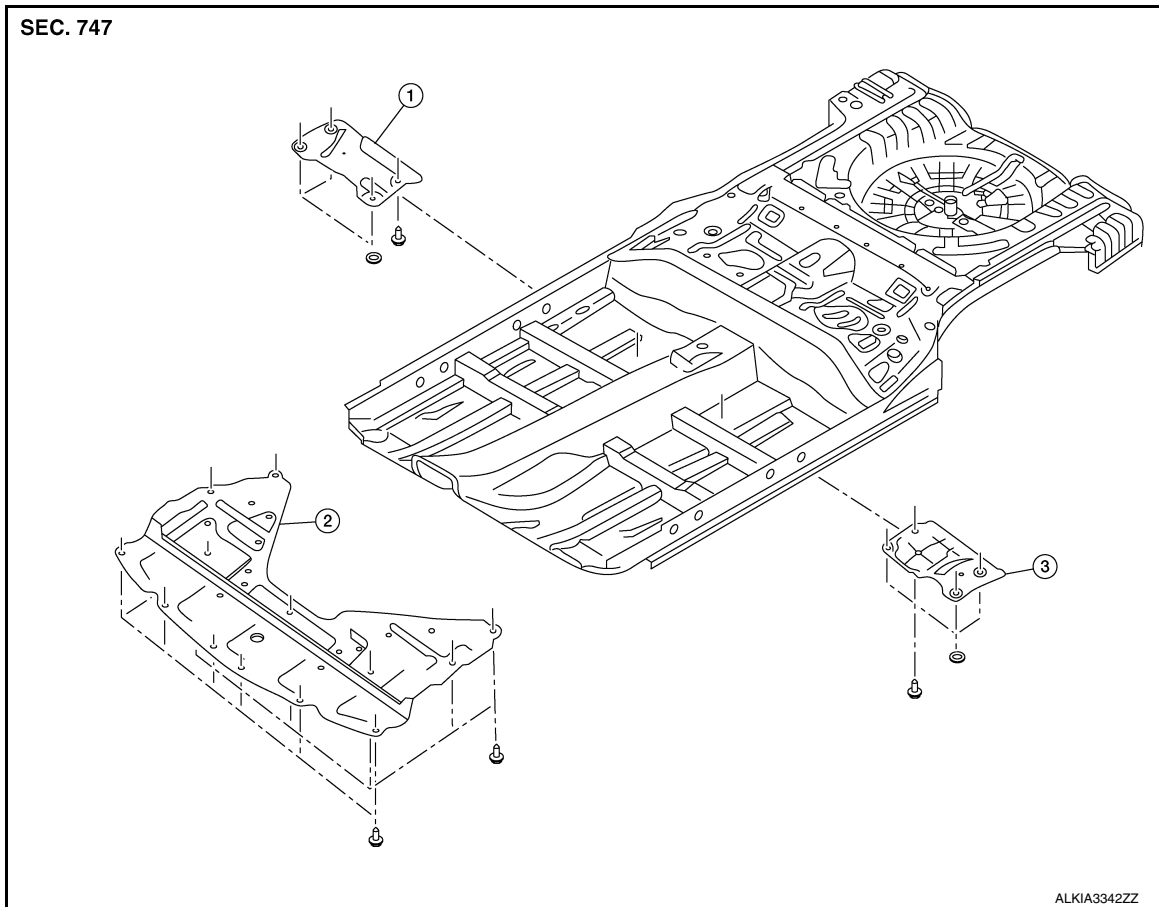

1. Floor under cover (RH)

2. Engine under cover

3. Floor under cover (LH)

ENGINE UNDER COVER

ENGINE UNDER COVER : Removal and Installation

INFOID:000000009795104

REMOVAL

1. Remove engine under cover clips.
2. Remove engine under cover.

INSTALLATION

Installation is in the reverse order of removal.

CAUTION:

When installing engine under covers, check that clips are securely placed in body panel holes.

FLOOR UNDER COVER

FLOOR UNDER COVER : Removal and Installation

INFOID:000000010269485

REMOVAL

A
B
C
D
E
F
G
H
I
J

EXT

L
M
N
O
P

UNDER COVER

< REMOVAL AND INSTALLATION >

1. Remove floor under cover clip (B) and nuts (A).
2. Remove floor under cover (1).

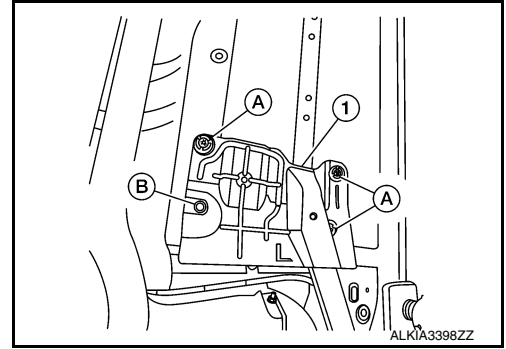

INSTALLATION

Install in the reverse order of removal.

CAUTION:

When installing floor under covers, check that clips are securely placed in body panel holes.

ROOF SIDE MOLDING

< REMOVAL AND INSTALLATION >

ROOF SIDE MOLDING

Exploded View

INFOID:000000009795105

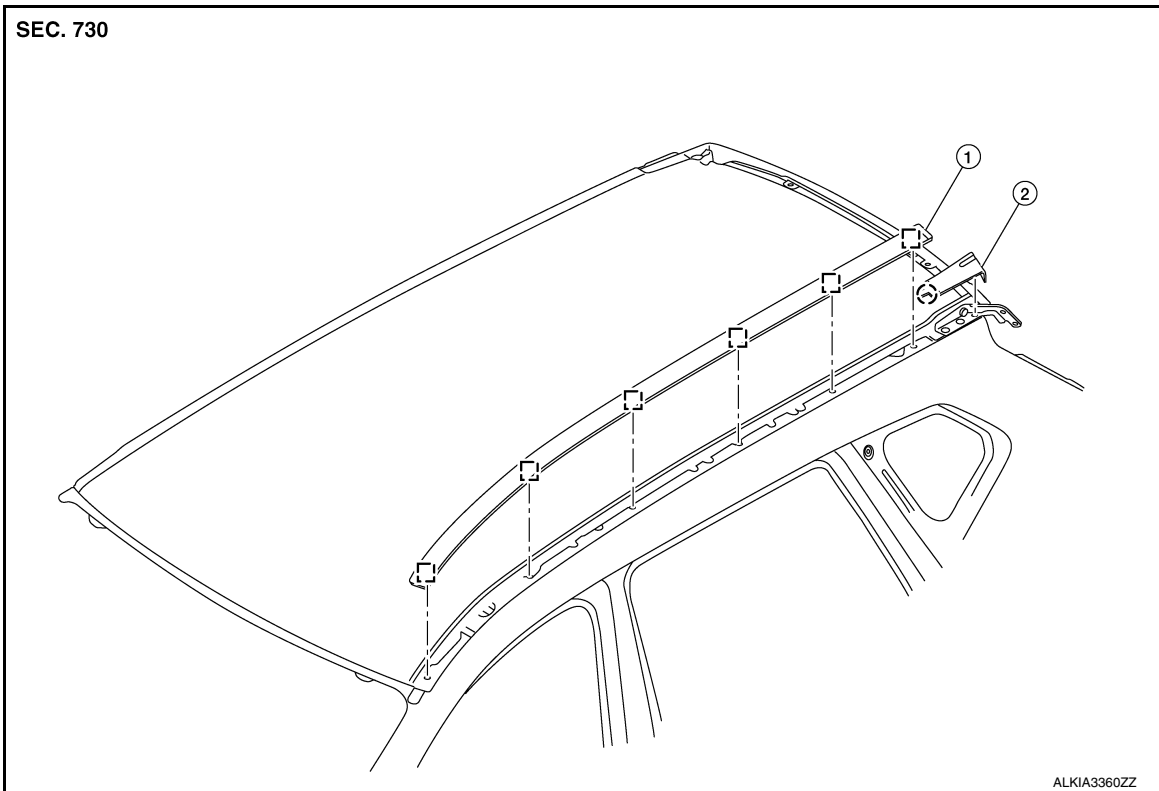

1. Roof side molding

2. Back door hinge cover

 Metal clip

 Pawl

Removal and Installation

INFOID:000000009795106

EXT

REMOVAL

1. Release roof side molding (1) using suitable tool (A) then remove roof side molding.

 Metal clip

CAUTION:

Apply protective tape (B) around the roof side molding.

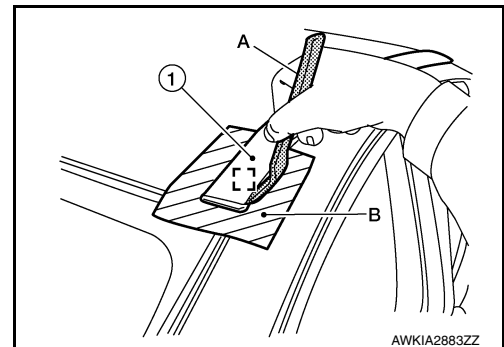

INSTALLATION

Installation is in the reverse order of removal.

CAUTION:

When installing roof side molding, check that clips are securely placed in body panel holes.

DOOR SASH MOLDING

< REMOVAL AND INSTALLATION >

DOOR SASH MOLDING

Exploded View

INFOID:000000010269698

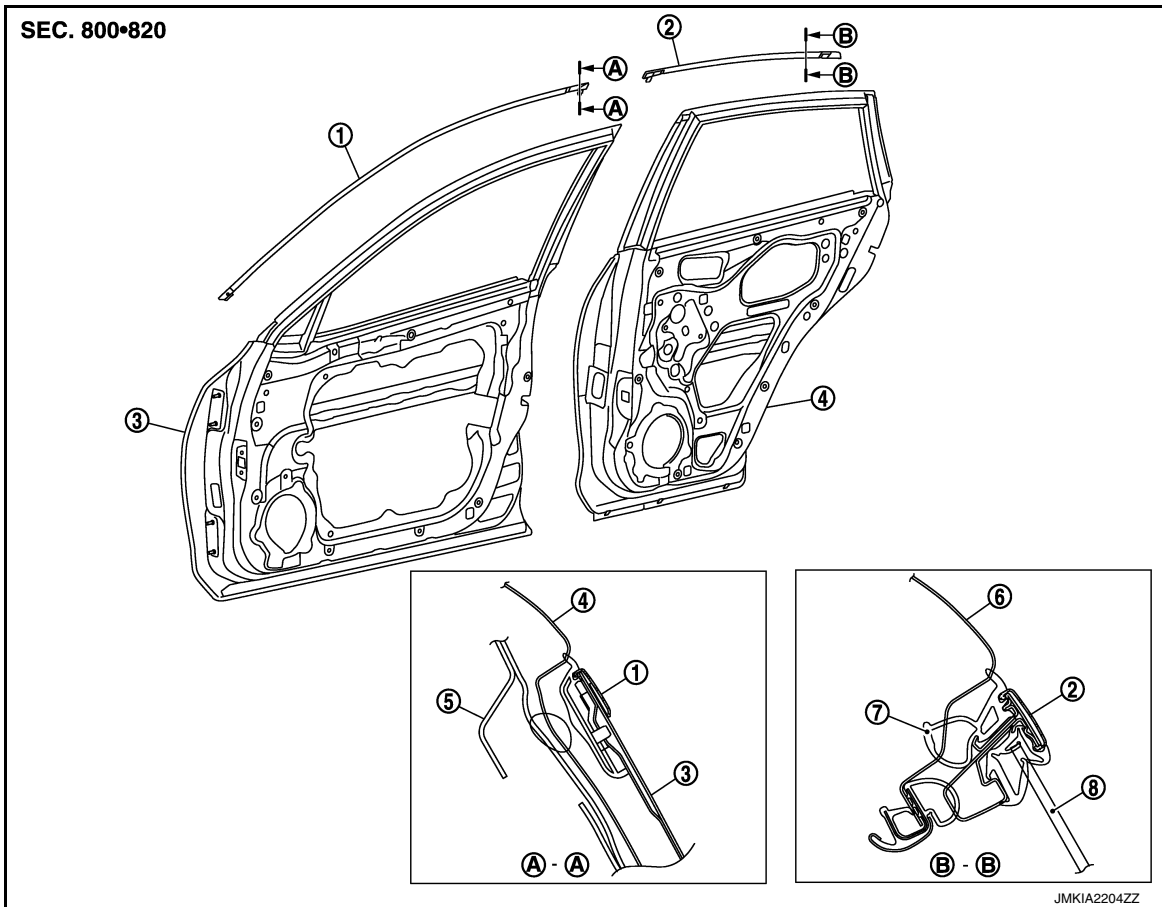

- | | | |
|----------------------------|--------------------------------|---------------------|
| 1. Front door sash molding | 2. Rear door rear sash molding | 3. Front door panel |
| 4. Rear door panel | 5. Roof rail side outer | 6. Body side outer |
| 7. Rear door weather strip | 8. Rear door glass | |

Removal and Installation

INFOID:000000010269699

FRONT DOOR

Removal

1. Remove door mirror. Refer to [MIR-22. "Removal and Installation"](#).
2. Remove front door sash molding clip (A) using a suitable tool (B).

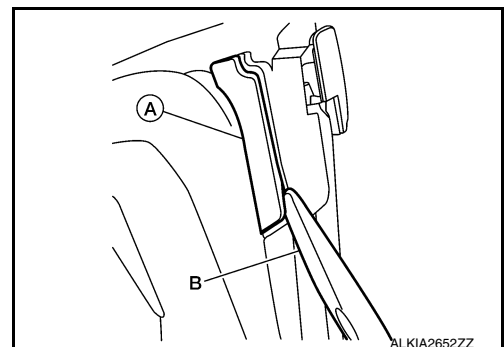

DOOR SASH MOLDING

< REMOVAL AND INSTALLATION >

- Using a suitable tool (A) remove front door sash molding (1) as shown and remove.

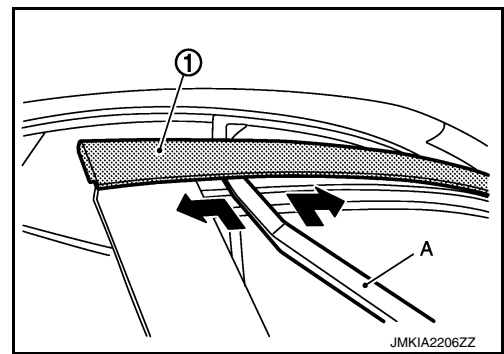

INSTALLATION

Installation is in the reverse order of removal.

REAR DOOR

Removal

- Remove rear door finisher. Refer to [INT-18, "Removal and Installation"](#).
- Remove rear door front sash molding clip (A) using a suitable tool (B).

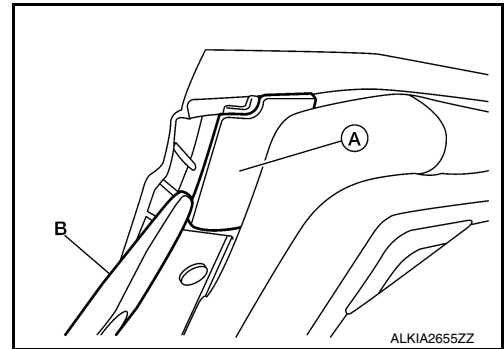

- Remove rear door rear sash molding clip (A) using a suitable tool (B).

CAUTION:

Do not reuse the clip (A).

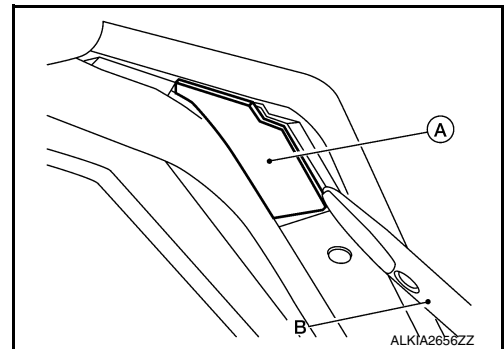

- Using a suitable tool (A) remove rear door sash molding (1) as shown and remove.

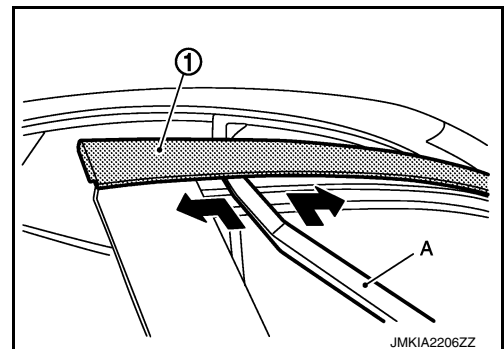

INSTALLATION

Installation is in the reverse order of removal.

A
B
C
D
E
F
G
H
I
J
EXT
L
M
N
O
P

DOOR OUTSIDE MOLDING

< REMOVAL AND INSTALLATION >

DOOR OUTSIDE MOLDING

Exploded View

INFOID:000000009795109

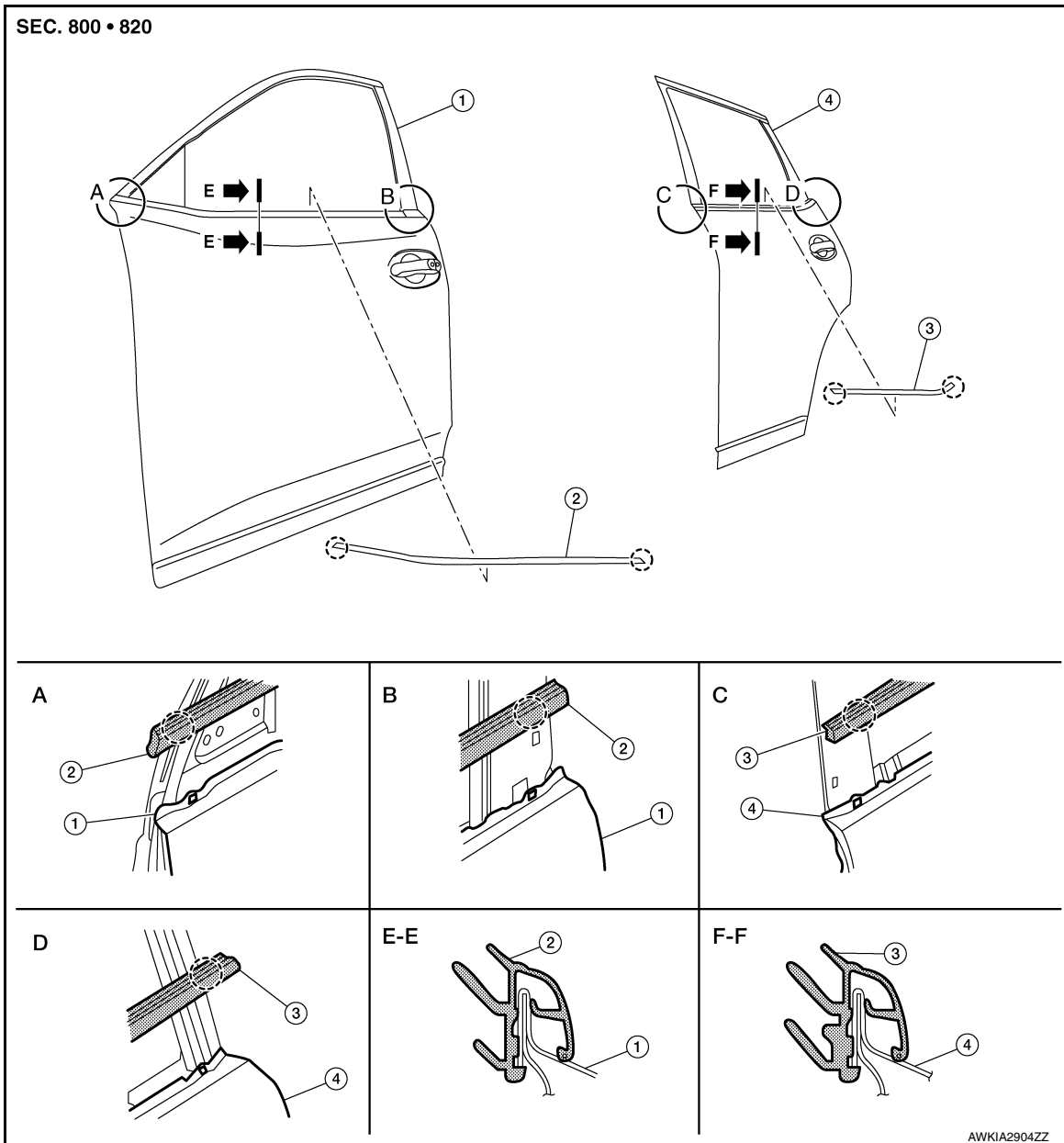

- | | | |
|------------------------------|-------------------------------|--------------------|
| 1. Front door panel | 2. Front door outside molding | 3. Rear door panel |
| 4. Rear door outside molding | ⊖ Pawl | |

Removal and Installation

INFOID:000000009795110

FRONT DOOR OUTSIDE MOLDING

Removal

1. Lower front door glass.
2. Remove door mirror. Refer to [MIR-22. "Removal and Installation"](#).

DOOR OUTSIDE MOLDING

< REMOVAL AND INSTALLATION >

3. Release front pawl then rear pawl using a suitable tool (A) and remove door outside molding (1).

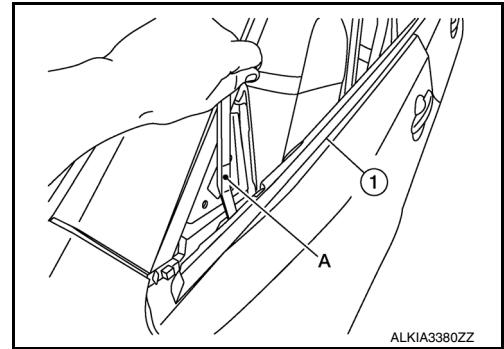

Installation

Installation is in the reverse order of removal.

REAR DOOR OUTSIDE MOLDING

Removal

1. Lower rear door glass.
2. Release front pawl then rear pawl using a suitable tool (A) and remove door outside molding (1).

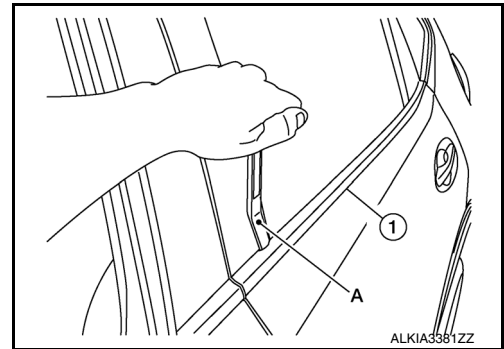

Installation

Installation is in the reverse order of removal.

A
B
C
D
E
F
G
H
I
J

EXT

L
M
N
O
P

ROOF RACK

< REMOVAL AND INSTALLATION >

ROOF RACK

Exploded View

INFOID:000000009795107

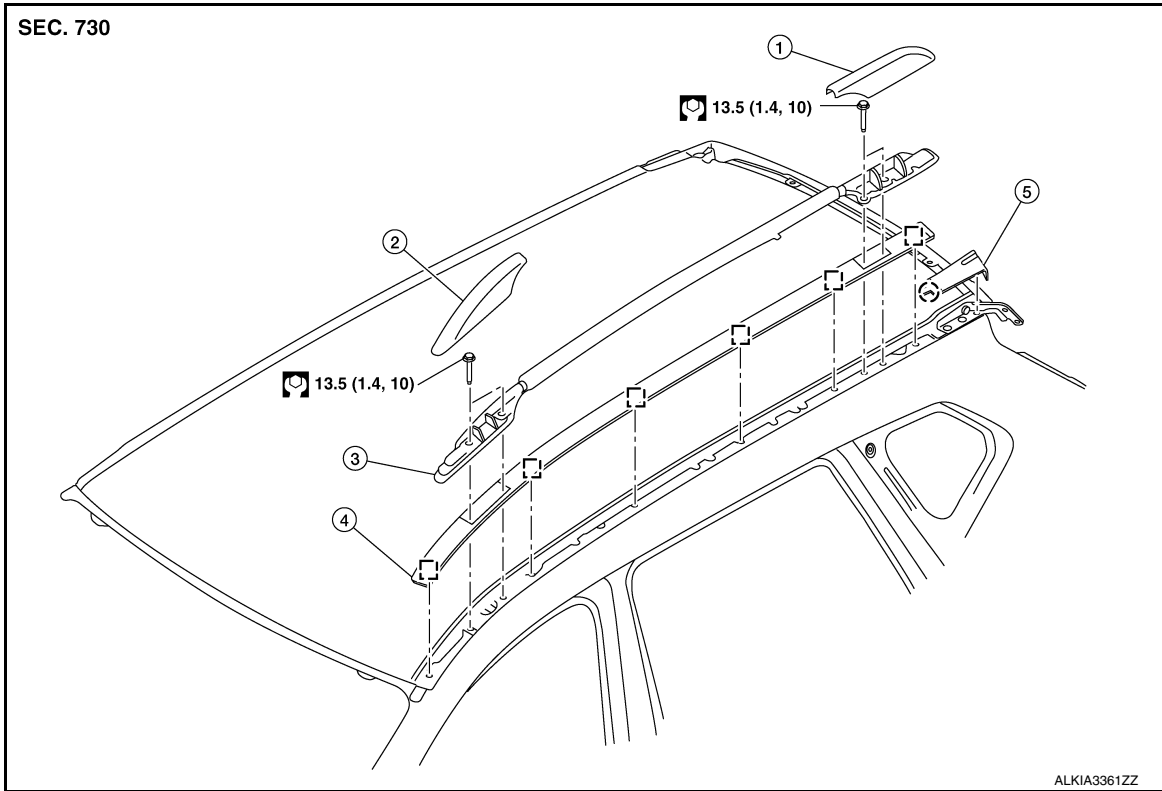

- | | | |
|------------------------------|-------------------------------|--------------|
| 1. Roof rack rear bolt cover | 2. Roof rack front bolt cover | 3. Roof rack |
| 4. Roof side molding | 5. Back door hinge cover | ⊞ Metal Clip |
| ⊞ Pawl | | |

Removal and Installation

INFOID:000000009795108

REMOVAL

1. Release pawls and remove roof rack front and rear cover (1) using suitable tool (A).

⊞: Pawl

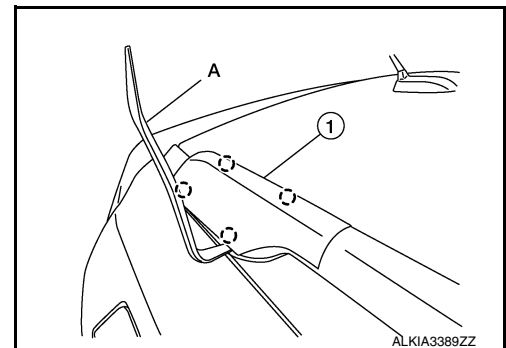

2. Remove bolts and remove roof rack.

INSTALLATION

Installation is in the reverse order of removal.

DOOR OUTSIDE LOWER MOLDING

< REMOVAL AND INSTALLATION >

DOOR OUTSIDE LOWER MOLDING

Exploded View

INFOID:000000010249318

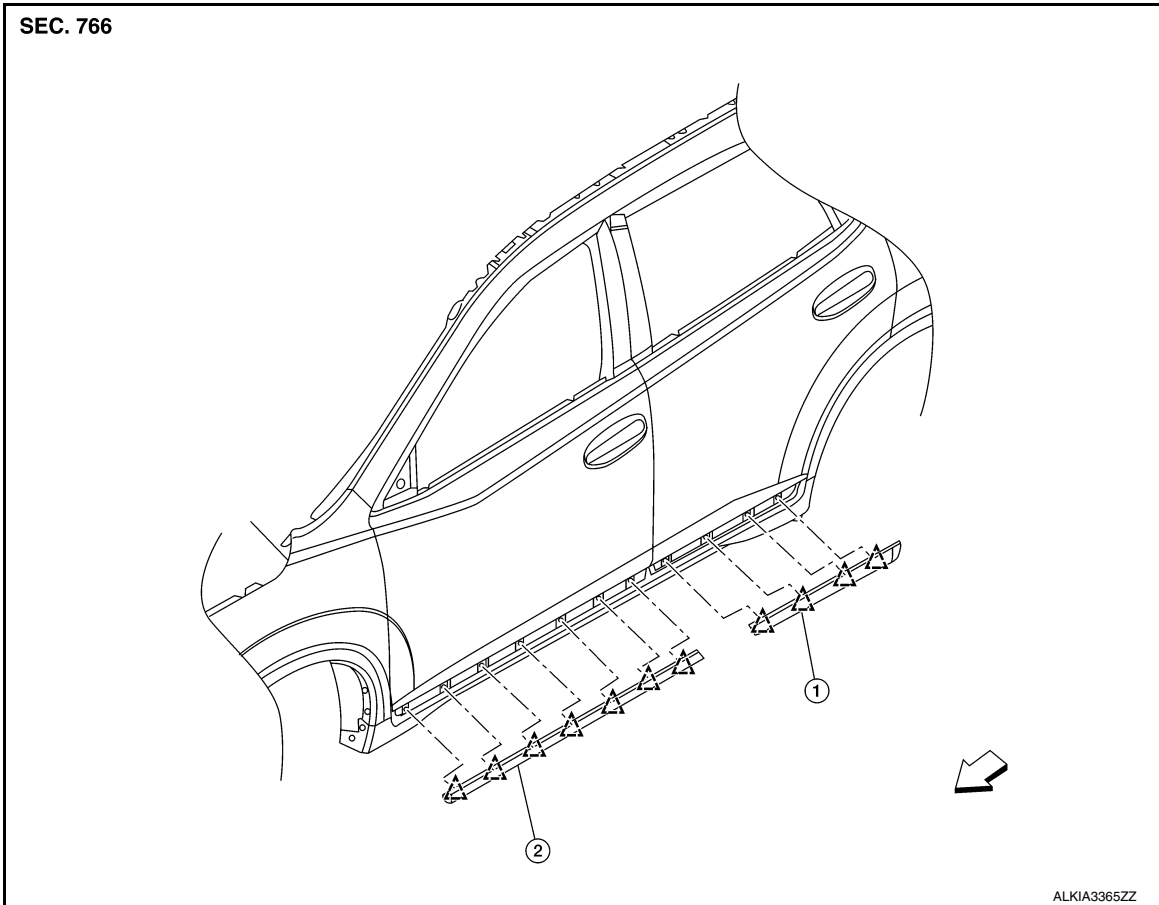

1. Rear door outside lower molding 2. Front door outside lower molding  Clip

 Front

Removal and Installation

INFOID:000000010249319

FRONT DOOR OUTSIDE LOWER MOLDING

Removal

1. Using a suitable tool (A) release clips from front door outside lower molding (1) starting at the rear and working forward.

CAUTION:

- Release the clips slowly and carefully.
- Do not pull the front door outside lower molding.

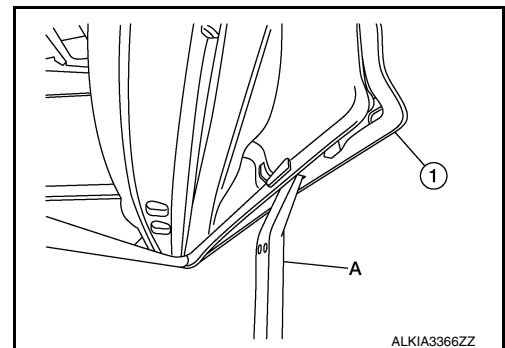

2. Remove the front door outside lower molding.

Installation

Installation is in the reverse order of removal.

A
B
C
D
E
F
G
H
I
J

EXT

L
M
N
O
P

DOOR OUTSIDE LOWER MOLDING

< REMOVAL AND INSTALLATION >

CAUTION:

- Do not reuse double-sided tape, always replace with new tape.
- When installing, visually check the front door outside lower molding and clips, replace with new clips if they have been damaged.
- When installing front door outside lower molding, make sure clips are attached to the molding. Make sure old clips have all been removed from door.

NOTE:

Install new double-sided tape (A) to front door outside lower molding as shown.

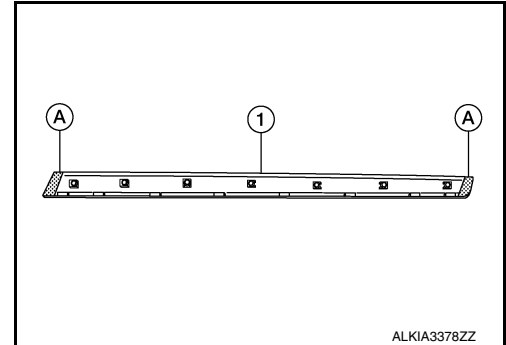

REAR DOOR OUTSIDE LOWER MOLDING

Removal

1. Using a suitable tool (A) release clips from rear door outside lower molding (1) starting at the rear and working forward.

CAUTION:

- Release the clips slowly and carefully.
- Do not pull the front door outside lower molding.

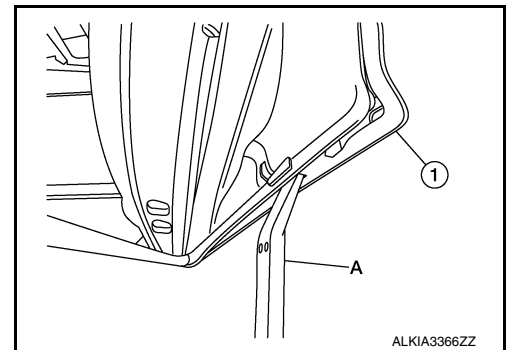

2. Remove the rear door outside lower molding.

Installation

Installation is in the reverse order of removal.

CAUTION:

- Do not reuse double-sided tape, always replace with new tape.
- When installing, visually check the front door outside lower molding and clips, replace with new clips if they have been damaged.
- When installing front door outside lower molding, make sure clips are attached to the molding. Make sure old clips have all been removed from door.

NOTE:

Install new double-sided tape (A) to front door outside lower molding as shown.

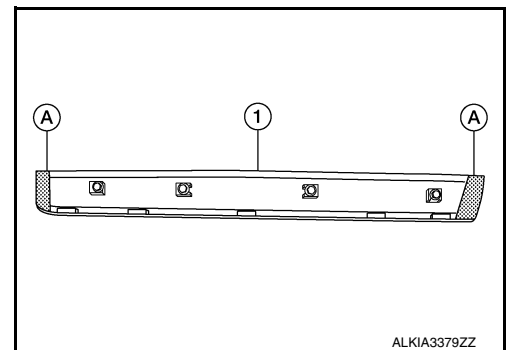

REAR SPOILER

< REMOVAL AND INSTALLATION >

REAR SPOILER

Removal and Installation

INFOID:000000010351307

The rear spoiler is part of the back door assembly. Refer to [DLK-248. "BACK DOOR ASSEMBLY : Removal and Installation"](#) (WITH INTELLIGENT KEY SYSTEM) or [DLK-365. "BACK DOOR ASSEMBLY : Removal and Installation"](#) (WITHOUT INTELLIGENT KEY SYSTEM).

A
B
C
D
E
F
G
H
I
J
L
M
N
O
P

EXT

SIDE AIR SPOILER

< REMOVAL AND INSTALLATION >

SIDE AIR SPOILER

Exploded View

INFOID:000000009795115

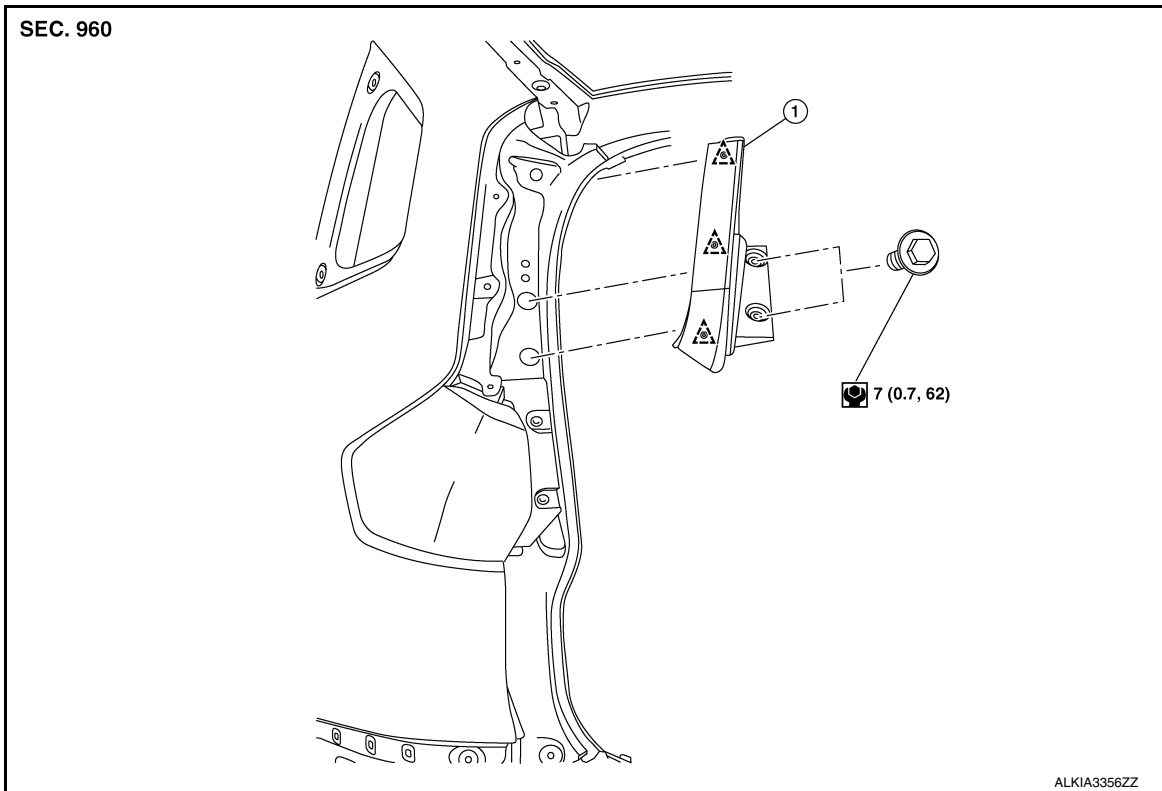

1. Side air spoiler

△ Clip

Removal and Installation

INFOID:000000009795116

REMOVAL

1. Remove side air spoiler bolts (A).

1: Side air spoiler

B: Clips

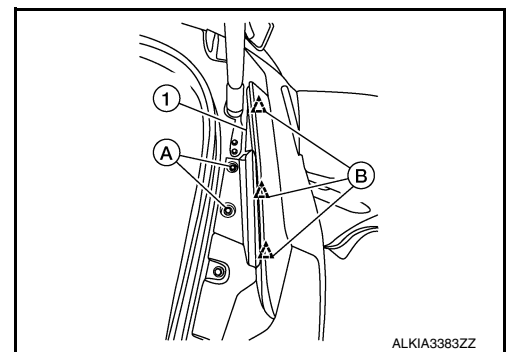

2. Release clips using suitable tool (A) and remove side air spoiler (1).

△: Clips

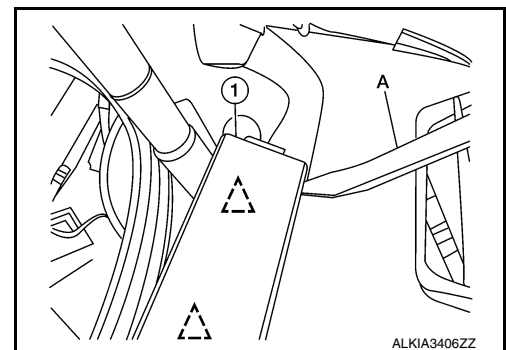

SIDE AIR SPOILER

< REMOVAL AND INSTALLATION >

INSTALLATION

Installation is in the reverse order of removal.

CAUTION:

- **When installing, visually check the side air spoiler and clips and replace them with new parts if they have been damaged.**
- **When installing side air spoiler, check that clips and bolts are securely placed in body panel holes.**

A

B

C

D

E

F

G

H

I

J

EXT

L

M

N

O

P

BACK DOOR OUTER FINISHER

< REMOVAL AND INSTALLATION >

BACK DOOR OUTER FINISHER

Exploded View

INFOID:000000009795117

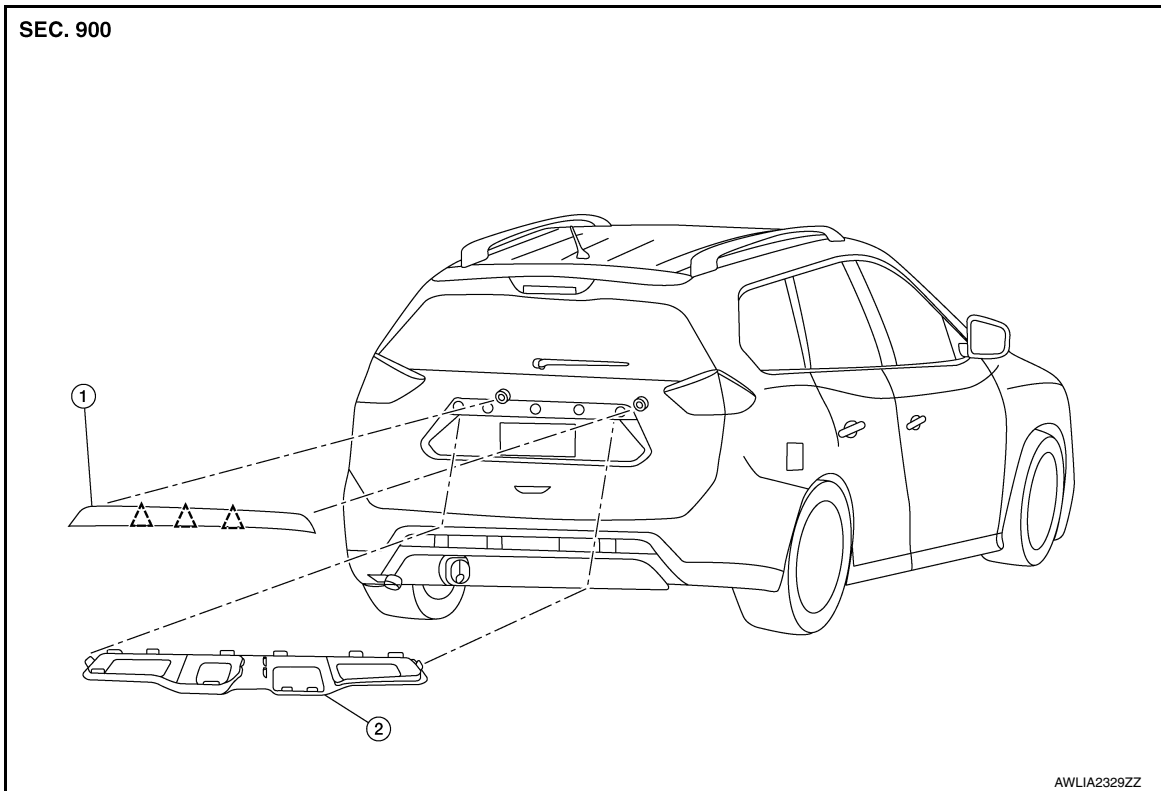

1. Back door outer finisher

2. License lamp finisher

 Clip

Removal and Installation

INFOID:000000009795118

REMOVAL

1. Remove back door finisher. Refer to [INT-38, "Removal and Installation"](#).
2. Remove plugs (A) from back door (1).

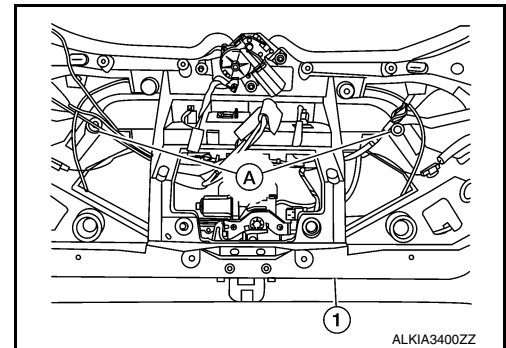

3. Remove back door outer finisher nuts.

BACK DOOR OUTER FINISHER

< REMOVAL AND INSTALLATION >

4. Release clips using suitable tool (A) and remove back door outer finisher (1).

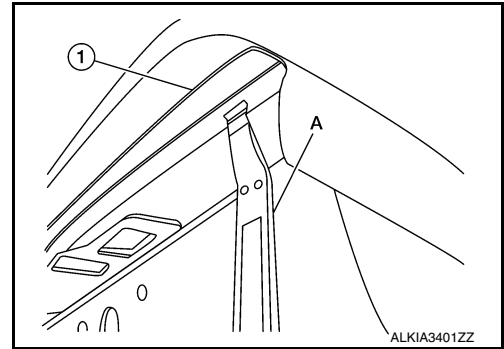

INSTALLATION

Installation is in the reverse order of removal.

CAUTION:

When installing back door outer finisher, check that clips are securely placed in back door panel holes.

A
B
C
D
E
F
G
H
I
J
L
M
N
O
P

EXT