

SECTION **RF**  
ROOF

A  
B  
C  
D  
E  
F  
G  
H  
I  
J  
RF  
L  
M  
N  
O  
P

CONTENTS

<b>PRECAUTION</b> .....	3	COMMON ITEM : CONSULT Function (BCM - COMMON ITEM) .....	11
<b>PRECAUTIONS</b> .....	3	<b>RETAINED PWR</b> .....	11
Precaution for Supplemental Restraint System (SRS) "AIR BAG" and "SEAT BELT PRE-TENSIONER" .....	3	RETAINED PWR : CONSULT Function (BCM - RETAINED PWR) .....	11
Precaution for Work .....	3	<b>ECU DIAGNOSIS INFORMATION</b> .....	13
<b>PREPARATION</b> .....	4	<b>BCM</b> .....	13
<b>PREPARATION</b> .....	4	List of ECU Reference .....	13
Special Service Tool .....	4	<b>MOONROOF MOTOR ASSEMBLY</b> .....	14
Commercial Service Tools .....	4	Reference Value .....	14
<b>SYSTEM DESCRIPTION</b> .....	5	<b>SUNSHADE MOTOR ASSEMBLY</b> .....	16
<b>COMPONENT PARTS</b> .....	5	Reference Value .....	16
<b>MOONROOF</b> .....	5	<b>WIRING DIAGRAM</b> .....	17
MOONROOF : Component Parts Location .....	5	<b>MOONROOF SYSTEM</b> .....	17
MOONROOF : Component Description .....	5	Wiring Diagram .....	17
<b>SYSTEM</b> .....	7	<b>BASIC INSPECTION</b> .....	22
<b>MOONROOF</b> .....	7	<b>DIAGNOSIS AND REPAIR WORKFLOW</b> .....	22
MOONROOF : System Diagram .....	7	Work Flow .....	22
MOONROOF : System Description .....	7	<b>INSPECTION AND ADJUSTMENT</b> .....	24
<b>DIAGNOSIS SYSTEM (BCM) (WITH INTELLIGENT KEY SYSTEM)</b> .....	9	<b>ADDITIONAL SERVICE WHEN REPLACING CONTROL UNIT</b> .....	24
<b>COMMON ITEM</b> .....	9	ADDITIONAL SERVICE WHEN REPLACING CONTROL UNIT : Special Repair Requirement .....	24
COMMON ITEM : CONSULT Function (BCM - COMMON ITEM) .....	9	<b>DTC/CIRCUIT DIAGNOSIS</b> .....	25
<b>RETAINED PWR</b> .....	9	<b>POWER SUPPLY AND GROUND CIRCUIT</b> .....	25
RETAINED PWR : CONSULT Function (BCM - RETAINED PWR) .....	10	<b>BCM (BODY CONTROL SYSTEM) (WITH INTELLIGENT KEY SYSTEM)</b> .....	25
<b>DIAGNOSIS SYSTEM (BCM) (WITHOUT INTELLIGENT KEY SYSTEM)</b> .....	11	BCM (BODY CONTROL SYSTEM) (WITH INTELLIGENT KEY SYSTEM) : Diagnosis Procedure .....	25
<b>COMMON ITEM</b> .....	11		

<b>BCM (BODY CONTROL SYSTEM) (WITHOUT INTELLIGENT KEY SYSTEM) .....</b>	<b>25</b>	<b>AUTO OPERATION DOES NOT OPERATE ...</b>	<b>40</b>
BCM (BODY CONTROL SYSTEM) (WITHOUT INTELLIGENT KEY SYSTEM) : Diagnosis Procedure .....	25	<b>MOONROOF .....</b>	<b>40</b>
<b>MOONROOF MOTOR ASSEMBLY .....</b>	<b>26</b>	MOONROOF : Diagnosis Procedure .....	40
MOONROOF MOTOR ASSEMBLY : Description...	26	<b>SUNSHADE .....</b>	<b>40</b>
MOONROOF MOTOR ASSEMBLY :		SUNSHADE : Diagnosis Procedure .....	40
Component Function Check .....	26	<b>ANTI-PINCH FUNCTION DOES NOT OPERATE .....</b>	<b>41</b>
MOONROOF MOTOR ASSEMBLY :		<b>MOONROOF .....</b>	<b>41</b>
Diagnosis Procedure .....	26	MOONROOF : Diagnosis Procedure .....	41
MOONROOF MOTOR ASSEMBLY : Special Repair Requirement .....	29	<b>SUNSHADE .....</b>	<b>41</b>
<b>SUNSHADE MOTOR ASSEMBLY .....</b>	<b>29</b>	SUNSHADE : Diagnosis Procedure .....	41
SUNSHADE MOTOR ASSEMBLY : Description ...	29	<b>RETAINED POWER OPERATION DOES NOT OPERATE PROPERLY .....</b>	<b>42</b>
SUNSHADE MOTOR ASSEMBLY :		Diagnosis Procedure .....	42
Component Function Check .....	29	<b>SQUEAK AND RATTLE TROUBLE DIAGNOSES .....</b>	<b>43</b>
SUNSHADE MOTOR ASSEMBLY :		Work Flow .....	43
Diagnosis Procedure .....	29	Generic Squeak and Rattle Troubleshooting .....	44
<b>MOONROOF SWITCH .....</b>	<b>31</b>	Diagnostic Worksheet .....	47
Description .....	31	<b>REMOVAL AND INSTALLATION .....</b>	<b>49</b>
Diagnosis Procedure .....	31	<b>GLASS LID .....</b>	<b>49</b>
Component Inspection .....	32	Exploded View .....	49
<b>DOOR SWITCH .....</b>	<b>34</b>	Removal and Installation .....	49
<b>WITH INTELLIGENT KEY .....</b>	<b>34</b>	<b>PANORAMIC ROOF GLASS .....</b>	<b>51</b>
WITH INTELLIGENT KEY :		Exploded View .....	51
Component Function Check .....	34	Removal and Installation .....	51
WITH INTELLIGENT KEY : Diagnosis Procedure..	34	<b>MOONROOF MOTOR ASSEMBLY .....</b>	<b>53</b>
WITH INTELLIGENT KEY : Component Inspection .....	35	Exploded View .....	53
<b>WITHOUT INTELLIGENT KEY .....</b>	<b>35</b>	Removal and Installation .....	53
WITHOUT INTELLIGENT KEY : Description .....	35	<b>MOONROOF UNIT ASSEMBLY .....</b>	<b>55</b>
WITHOUT INTELLIGENT KEY :		Inspection .....	55
Component Function Check .....	35	Exploded View .....	59
WITHOUT INTELLIGENT KEY : Diagnosis Procedure .....	36	Removal and Installation .....	59
WITHOUT INTELLIGENT KEY : Component Inspection .....	37	<b>SUNSHADE .....</b>	<b>61</b>
<b>SYMPTOM DIAGNOSIS .....</b>	<b>38</b>	Removal and Installation .....	61
<b>MOONROOF DOES NOT OPERATE PROPERLY .....</b>	<b>38</b>	<b>SUNSHADE MOTOR ASSEMBLY .....</b>	<b>62</b>
Diagnosis Procedure .....	38	Removal and Installation .....	62
<b>SUNSHADE SYSTEM DOES NOT OPERATE PROPERLY .....</b>	<b>39</b>	<b>WIND DEFLECTOR .....</b>	<b>63</b>
Diagnosis Procedure .....	39	Removal and Installation .....	63
		<b>MOONROOF SWITCH .....</b>	<b>64</b>
		Removal and Installation .....	64

# PRECAUTIONS

< PRECAUTION >

## PRECAUTION

### PRECAUTIONS

#### Precaution for Supplemental Restraint System (SRS) "AIR BAG" and "SEAT BELT PRE-TENSIONER"

INFOID:000000010308754

The Supplemental Restraint System such as "AIR BAG" and "SEAT BELT PRE-TENSIONER", used along with a front seat belt, helps to reduce the risk or severity of injury to the driver and front passenger for certain types of collision. Information necessary to service the system safely is included in the SR and SB section of this Service Manual.

#### **WARNING:**

- To avoid rendering the SRS inoperative, which could increase the risk of personal injury or death in the event of a collision which would result in air bag inflation, all maintenance must be performed by an authorized NISSAN/INFINITI dealer.
- Improper maintenance, including incorrect removal and installation of the SRS, can lead to personal injury caused by unintentional activation of the system. For removal of Spiral Cable and Air Bag Module, see the SR section.
- Do not use electrical test equipment on any circuit related to the SRS unless instructed to in this Service Manual. SRS wiring harnesses can be identified by yellow and/or orange harnesses or harness connectors.

#### PRECAUTIONS WHEN USING POWER TOOLS (AIR OR ELECTRIC) AND HAMMERS

#### **WARNING:**

- When working near the Airbag Diagnosis Sensor Unit or other Airbag System sensors with the Ignition ON or engine running, DO NOT use air or electric power tools or strike near the sensor(s) with a hammer. Heavy vibration could activate the sensor(s) and deploy the air bag(s), possibly causing serious injury.
- When using air or electric power tools or hammers, always switch the Ignition OFF, disconnect the battery and wait at least three minutes before performing any service.

#### Precaution for Work

INFOID:000000010308753

- When removing or disassembling each component, be careful not to damage or deform it. If a component may be subject to interference, be sure to protect it with a shop cloth.
- When removing (disengaging) components with a screwdriver or similar tool, be sure to wrap the component with a shop cloth or vinyl tape to protect it.
- Protect the removed parts with a shop cloth and prevent them from being dropped.
- Replace a deformed or damaged clip.
- If a part is specified as a non-reusable part, always replace it with a new one.
- Be sure to tighten bolts and nuts securely to the specified torque.
- After installation is complete, be sure to check that each part works properly.
- Follow the steps below to clean components:
  - Water soluble dirt:
    - Dip a soft cloth into lukewarm water, wring the water out of the cloth and wipe the dirty area.
    - Then rub with a soft, dry cloth.
  - Oily dirt:
    - Dip a soft cloth into lukewarm water with mild detergent (concentration: within 2 to 3%) and wipe the dirty area.
    - Then dip a cloth into fresh water, wring the water out of the cloth and wipe the detergent off.
    - Then rub with a soft, dry cloth.
  - Do not use organic solvent such as thinner, benzene, alcohol or gasoline.
  - For genuine leather seats, use a genuine leather seat cleaner.

# PREPARATION

< PREPARATION >

## PREPARATION

### PREPARATION

#### Special Service Tool

INFOID:000000010308758

The actual shape of the tools may differ from those illustrated here.

Tool number (TechMate No.) Tool name	Description
— (J-39570) Chassis Ear	Locating the noise
— (J-50397) NISSAN Squeak and Rattle Kit	Repairing the cause of noise
— (J-46534) Trim Tool Set	Removing trim components

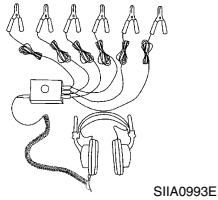

SIIA0993E



ALJIA1232ZZ

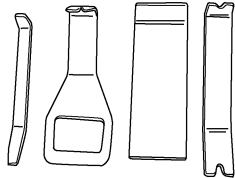

AWJIA0483ZZ

#### Commercial Service Tools

INFOID:000000010308759

(TechMate No.) Tool name	Description
(J-39565) Engine Ear	Locating the noise
( — ) Power tool	Loosening nuts, screws and bolts

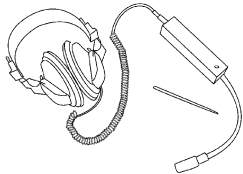

SIIA0995E



PIIB1407E

# COMPONENT PARTS

< SYSTEM DESCRIPTION >

## SYSTEM DESCRIPTION

### COMPONENT PARTS

#### MOONROOF

#### MOONROOF : Component Parts Location

INFOID:000000010247856

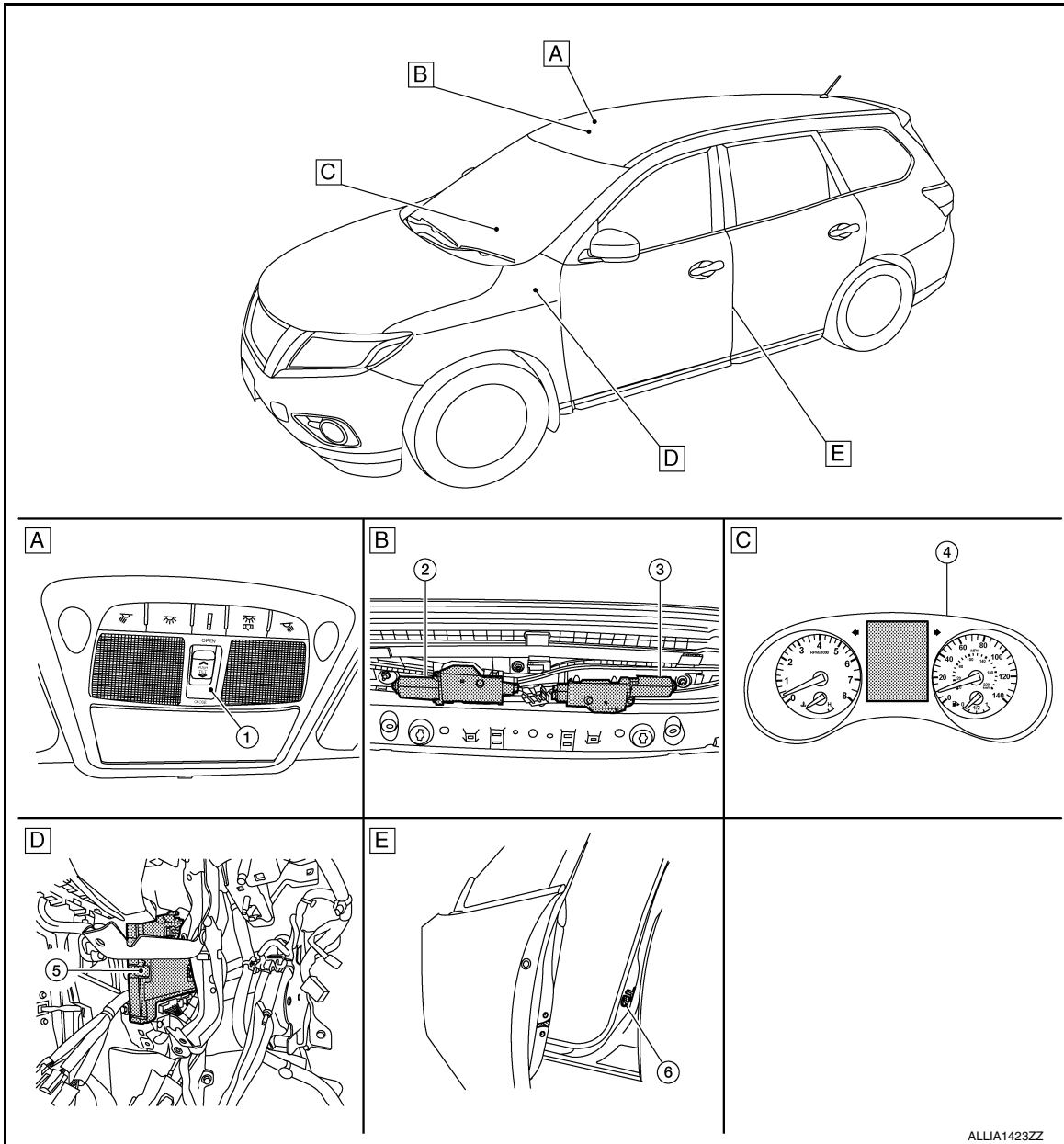

A  
B  
C  
D  
E  
F  
G  
H  
I  
J  
RF  
L  
M  
N  
O  
P

RF

- A. Moonroof switch
- B. View with headliner removed
- C. Combination meter
- D. Behind instrument panel (LH)
- E. View with LH door open (RH similar)

#### MOONROOF : Component Description

INFOID:000000010247857

No.	Component	Function
1.	Moonroof switch	Transmits open/close operation signal to the moonroof and sunshade motor assembly.
2.	Sunshade motor	The sunshade motor and CPU are integrated into one unit that opens/closes by input from the moonroof switch operation.

## COMPONENT PARTS

### < SYSTEM DESCRIPTION >

No.	Component	Function
3.	Moonroof motor	The moonroof motor and CPU are integrated into one unit that opens/closes by input from the moonroof switch operation.
4.	Combination meter	Transmits the vehicle speed signal to BCM via CAN communication.
5.	BCM	Supplies the power supply to the moonroof & sunshade motor assembly.
6.	Front door switch LH	Detects door open/close condition and transmits to BCM.

# SYSTEM

< SYSTEM DESCRIPTION >

## SYSTEM MOONROOF

### MOONROOF : System Diagram

INFOID:000000010247860

### MOONROOF & SUNSHADE

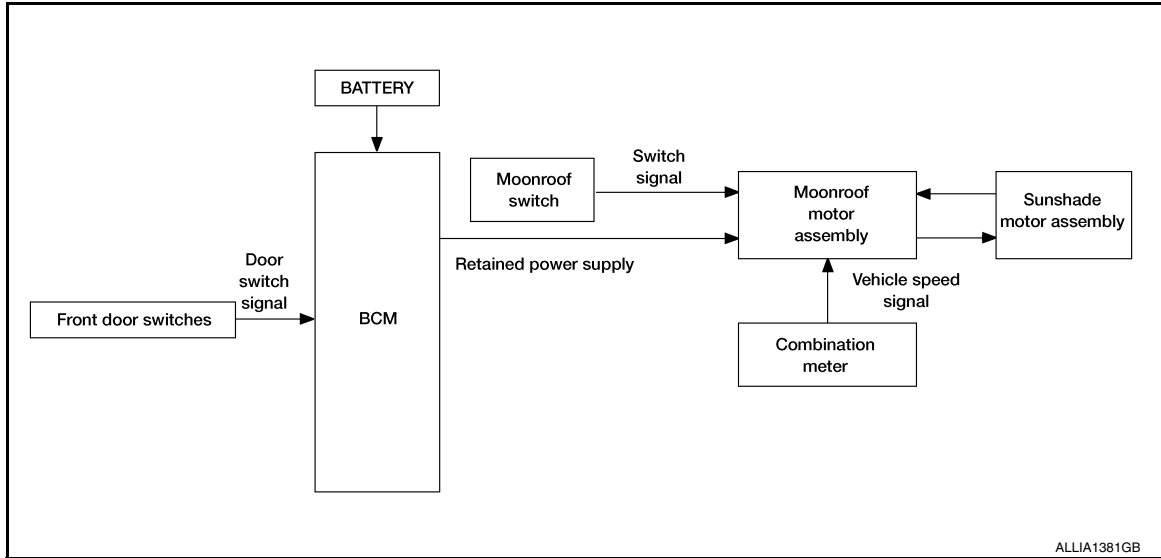

### MOONROOF : System Description

INFOID:000000010247861

### MOONROOF SYSTEM INPUT/OUTPUT SIGNAL CHART

Item	Input signal to moonroof motor assembly	Moonroof motor function	Actuator
Moonroof switch	Moonroof signal (tilt up/down or slide open/close)	Receives signal and moves the moonroof and sunshade assembly to the correct position.	Moonroof motor and/or Sunshade motor
	Sunshade signal (slide open/close)		
Combination meter	Vehicle speed signal	Receives speed signal and determines the amount of torque the motor requires.	
BCM	RAP signal	Retained power after the key is turned off and the front doors stay closed.	

### MOONROOF AND SUNSHADE OPERATION

- Moonroof motor and sunshade motor assembly operates with the power supply that is output from the BCM while the ignition switch is ON or retained power is operating.
- Tilt up/down & slide open/close signals from the moonroof switch enable the moonroof motor and sunshade motor to move.
- Moonroof motor assembly receives a vehicle speed signal from the combination meter and controls the moonroof motor torque of tilt down at the time of high speed operation.

### AUTO OPERATION

Moonroof and Sunshade AUTO feature makes it possible to slide open and slide closed the moonroof and sunshade without holding the moonroof switch in the slide open/close position.

### RETAINED POWER OPERATION

- Retained power operation is an additional power supply function that enables the moonroof and sunshade system to operate for 45 seconds after the ignition switch is turned off and the front doors remain closed.

Retained power function cancel conditions

A  
B  
C  
D  
E  
F  
G  
H  
I  
J  
L  
M  
N  
O  
P

RF

## SYSTEM

### < SYSTEM DESCRIPTION >

---

- Door CLOSE (door switch OFF)→OPEN (door switch ON).
- When ignition switch is ON again.
- When timer time passes (45 seconds).

### ANTI-PINCH FUNCTION

The moonroof and sunshade motor's built in CPU monitors the moonroof motor and sunshade motor operation and position.

If a restriction is detected during the slide closed operation the moonroof/sunshade motor will move the glass/sunshade in the open positions.



# DIAGNOSIS SYSTEM (BCM) (WITH INTELLIGENT KEY SYSTEM)

< SYSTEM DESCRIPTION >

## DIAGNOSIS SYSTEM (BCM) (WITH INTELLIGENT KEY SYSTEM) COMMON ITEM

COMMON ITEM : CONSULT Function (BCM - COMMON ITEM)

INFOID:000000010291450

### APPLICATION ITEM

CONSULT performs the following functions via CAN communication with BCM.

Direct Diagnostic Mode	Description
Ecu Identification	The BCM part number is displayed.
Self Diagnostic Result	The BCM self diagnostic results are displayed.
Data Monitor	The BCM input/output data is displayed in real time.
Active Test	The BCM activates outputs to test components.
Work support	The settings for BCM functions can be changed.
Configuration	<ul style="list-style-type: none"> <li>The vehicle specification can be read and saved.</li> <li>The vehicle specification can be written when replacing BCM.</li> </ul>
CAN Diag Support Mntr	The result of transmit/receive diagnosis of CAN communication is displayed.

### SYSTEM APPLICATION

BCM can perform the following functions.

System	Sub System	Direct Diagnostic Mode						
		Ecu Identification	Self Diagnostic Result	Data Monitor	Active Test	Work support	Configuration	CAN Diag Support Mntr
Door lock	DOOR LOCK		x	x	x	x		
Rear window defogger	REAR DEFOGGER			x	x	x		
Warning chime	BUZZER			x	x			
Interior room lamp timer	INT LAMP			x	x	x		
Exterior lamp	HEADLAMP			x	x	x		
Wiper and washer	WIPER			x	x	x		
Turn signal and hazard warning lamps	FLASHER			x	x			
Intelligent Key system	INTELLIGENT KEY		x	x	x	x		
Combination switch	COMB SW			x				
BCM	BCM	x	x			x	x	x
Immobilizer	IMMU		x	x	x			
Interior room lamp battery saver	BATTERY SAVER			x	x			
Back door open	TRUNK			x				
Vehicle security system	THEFT ALM			x	x	x		
RAP system	RETAINED PWR			x				
Signal buffer system	SIGNAL BUFFER			x				
TPMS	AIR PRESSURE MONITOR		x	x	x	x		

### RETAINED PWR

# DIAGNOSIS SYSTEM (BCM) (WITH INTELLIGENT KEY SYSTEM)

< SYSTEM DESCRIPTION >

RETAINED PWR : CONSULT Function (BCM - RETAINED PWR)

INFOID:000000010377882

## DATA MONITOR

Monitor Item [Unit]	Description
DOOR SW-DR [On/Off]	Indicates condition of front door switch LH.
DOOR SW-AS [On/Off]	Indicates condition of front door switch RH.

# DIAGNOSIS SYSTEM (BCM) (WITHOUT INTELLIGENT KEY SYSTEM)

< SYSTEM DESCRIPTION >

## DIAGNOSIS SYSTEM (BCM) (WITHOUT INTELLIGENT KEY SYSTEM) COMMON ITEM

COMMON ITEM : CONSULT Function (BCM - COMMON ITEM)

INFOID:0000000010291452

### APPLICATION ITEM

CONSULT performs the following functions via CAN communication with BCM.

Direct Diagnostic Mode	Description
Ecu Identification	The BCM part number is displayed.
Self Diagnostic Result	The BCM self diagnostic results are displayed.
Data Monitor	The BCM input/output data is displayed in real time.
Active Test	The BCM activates outputs to test components.
Work support	The settings for BCM functions can be changed.
Configuration	<ul style="list-style-type: none"> <li>The vehicle specification can be read and saved.</li> <li>The vehicle specification can be written when replacing BCM.</li> </ul>
CAN Diag Support Mntr	The result of transmit/receive diagnosis of CAN communication is displayed.

### SYSTEM APPLICATION

BCM can perform the following functions.

System	Sub System	Direct Diagnostic Mode						
		Ecu Identification	Self Diagnostic Result	Data Monitor	Active Test	Work support	Configuration	CAN Diag Support Mntr
Door lock	DOOR LOCK			x	x	x		
Rear window defogger	REAR DEFOGGER			x	x	x		
Warning chime	BUZZER			x	x			
Interior room lamp timer	INT LAMP			x	x	x		
Remote keyless entry system	MULTI REMOTE ENT					x		
Exterior lamp	HEADLAMP			x	x			
Wiper and washer	WIPER			x	x	x		
Turn signal and hazard warning lamps	FLASHER			x	x			
Combination switch	COMB SW			x				
BCM	BCM	x	x			x	x	x
Immobilizer	IMMU		x		x			
Interior room lamp battery saver	BATTERY SAVER			x	x			
Back door open	TRUNK			x				
Vehicle security system	THEFT ALM			x	x	x		
RAP system	RETAINED PWR			x				
TPMS	AIR PRESSURE MONITOR		x	x	x	x		

### RETAINED PWR

RETAINED PWR : CONSULT Function (BCM - RETAINED PWR)

INFOID:0000000010377883

### DATA MONITOR

# DIAGNOSIS SYSTEM (BCM) (WITHOUT INTELLIGENT KEY SYSTEM)

## < SYSTEM DESCRIPTION >

Monitor Item [Unit]	Description
DOOR SW-DR [On/Off]	Indicates condition of front door switch LH.
DOOR SW-AS [On/Off]	Indicates condition of front door switch RH.

# BCM

< ECU DIAGNOSIS INFORMATION >

## ECU DIAGNOSIS INFORMATION

### BCM

#### List of ECU Reference

INFOID:0000000010291449

ECU	Reference
BCM (with Intelligent Key system)	<a href="#">BCS-28, "Reference Value"</a>
	<a href="#">BCS-47, "Fail Safe"</a>
	<a href="#">BCS-47, "DTC Inspection Priority Chart"</a>
	<a href="#">BCS-48, "DTC Index"</a>
BCM (without Intelligent Key system)	<a href="#">BCS-96, "Reference Value"</a>
	<a href="#">BCS-107, "Fail Safe"</a>
	<a href="#">BCS-107, "DTC Inspection Priority Chart"</a>
	<a href="#">BCS-108, "DTC Index"</a>

A  
B  
C  
D  
E  
F  
G  
H  
I  
J  
RF  
L  
M  
N  
O  
P

# MOONROOF MOTOR ASSEMBLY

< ECU DIAGNOSIS INFORMATION >

## MOONROOF MOTOR ASSEMBLY

Reference Value

INFOID:000000010247867

### TERMINAL LAYOUT

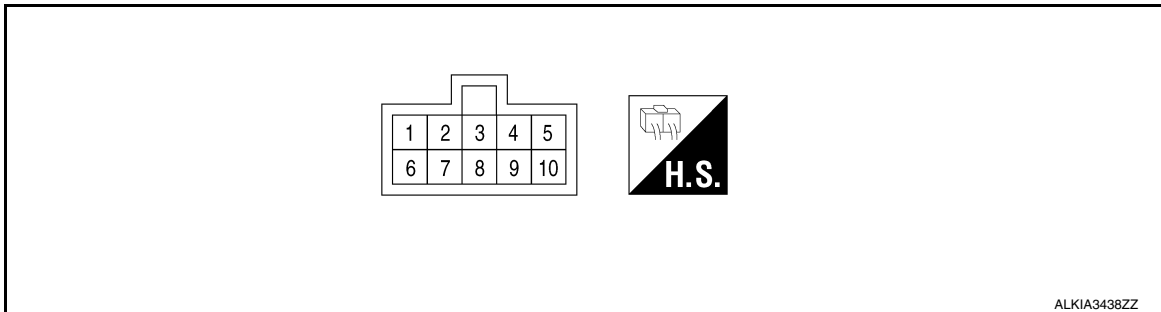

### PHYSICAL VALUES

Terminal No. (Wire color)		Description		Condition	Voltage (Approx.)
+	-	Signal name	Input/ Output		
1 (B)	Ground	Ground	—	—	0
2 (BR)	Ground	Sunshade open/close switch (second click) signal	Output	Moonroof switch in following (second click) position • OPEN • CLOSE	0
3 (Y)	Ground	Ign power supply from BCM	Input	—	Battery voltage
4 (W)	Ground	RAP signal	Input	Ignition switch ON	Battery voltage
				Within 45 seconds after ignition switch is turned to OFF.	Battery voltage
				When driver side or passenger side door is opened during re- tained power operation.	0
5 (L)	Ground	Moonroof OPEN switch signal	Input	Moonroof switch in following po- sition • TILT DOWN • SLIDE OPEN	0
				Other than above	Battery voltage
6 (R)	Ground	Moonroof power supply	Input	—	Battery voltage
7 (GR)	Ground	Serial communication line (between moonroof & sunshade motor)	Input/ Output	—	-
8 (G)	Ground	Vehicle speed signal	Input	Speedometer operated [When vehicle speed is approx.40km/h (25MPH)]	<p>The graph shows a square wave signal on a grid. The vertical axis is labeled 'V' and ranges from 0 to 6. The horizontal axis is labeled 'ms' and has a scale bar for 50ms. The signal is a square wave with a period of approximately 50ms and a peak-to-peak voltage of approximately 4V.</p>

ELF1080D

# MOONROOF MOTOR ASSEMBLY

## < ECU DIAGNOSIS INFORMATION >

Terminal No. (Wire color)		Description		Condition	Voltage (Approx.)
+	-	Signal name	Input/ Output		
10 (LG)	Ground	Moonroof CLOSE switch signal	Input	Moonroof switch in following po- sition • TILT UP • SLIDE CLOSE	0
				Other than above	Battery voltage

A  
B  
C  
D  
E  
F  
G  
H  
I  
J  
RF  
L  
M  
N  
O  
P

# SUNSHADE MOTOR ASSEMBLY

< ECU DIAGNOSIS INFORMATION >

## SUNSHADE MOTOR ASSEMBLY

Reference Value

INFOID:000000010247868

### TERMINAL LAYOUT

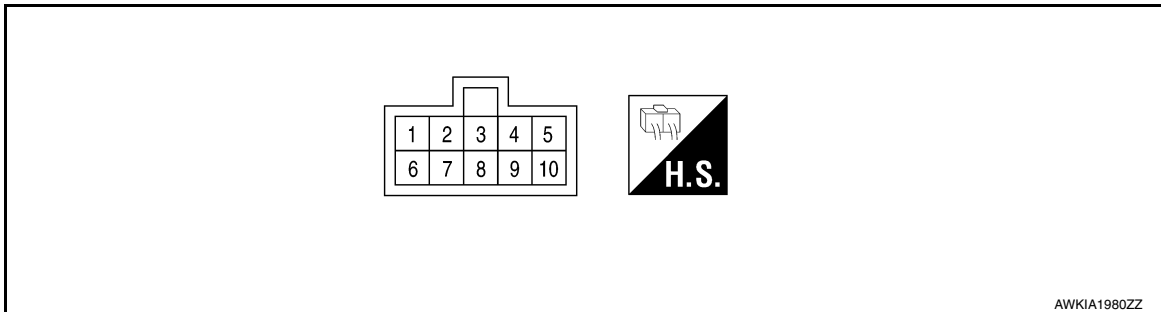

### PHYSICAL VALUES

Terminal No. (Wire color)		Description	Condition	Voltage (Approx.)
+	-	Signal name	Input/ Output	
1 (P)	Ground	Ground	—	0
3 (Y)	Ground	Ign power supply	Input	Within 45 seconds after the ignition is turned off
				Battery voltage
				When the driver side or passenger side door is opened during retained power operation.
				0
6 (V)	Ground	Bat + power supply	—	Battery voltage
7 (GR)	Ground	Sunshade open/close switch signal	Input/ Output	Sunshade switch is in the open/close position
				0
				Other than above
				Battery voltage



# MOONROOF SYSTEM

< WIRING DIAGRAM >

## WIRING DIAGRAM

### MOONROOF SYSTEM

Wiring Diagram

INFOID:000000010247869

#### MOONROOF SYSTEM

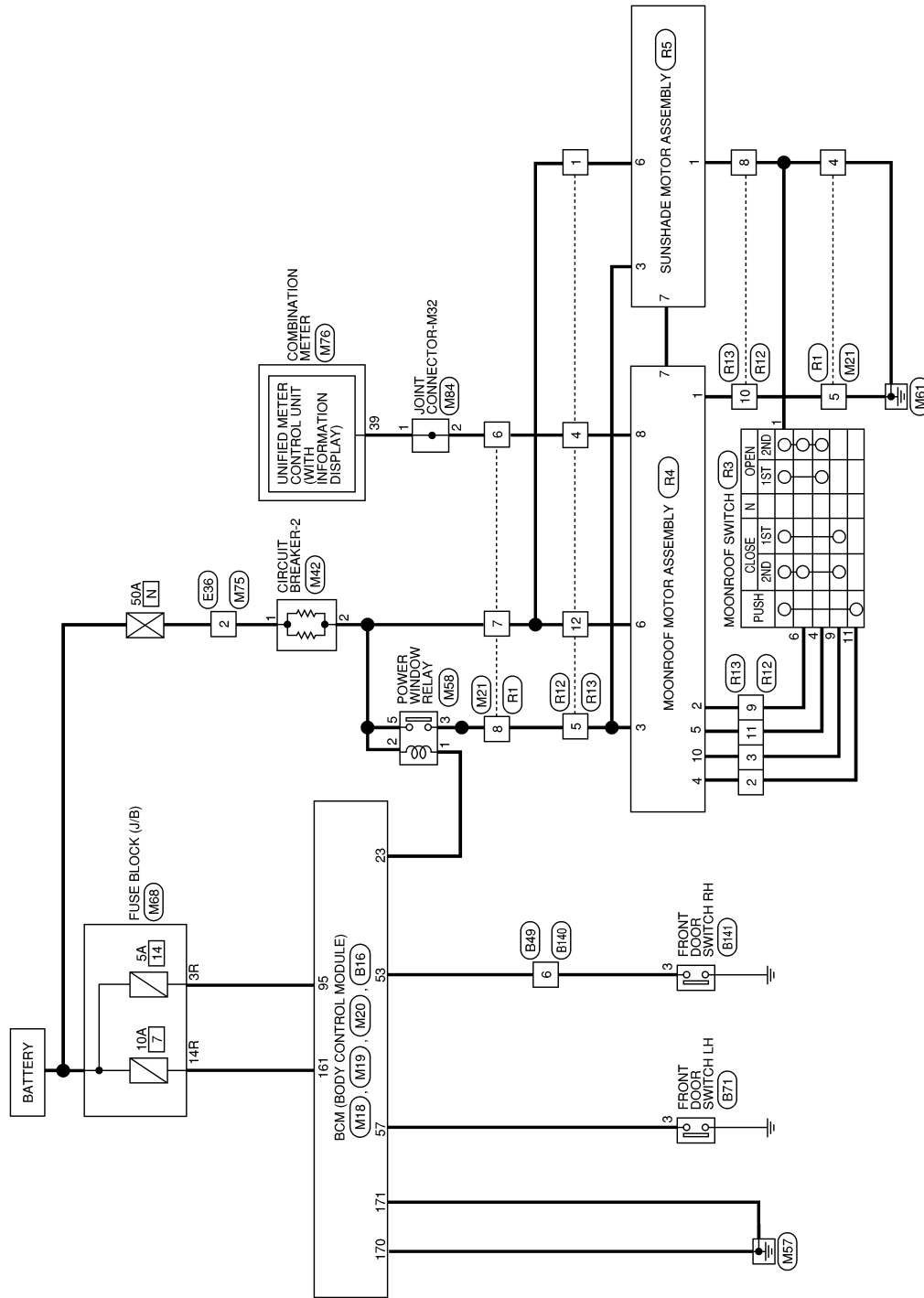

AAKWA0757GB

A  
B  
C  
D  
E  
F  
G  
H  
I  
J  
RF  
L  
M  
N  
O  
P

# MOONROOF SYSTEM

< WIRING DIAGRAM >

## MOONROOF SYSTEM CONNECTORS

Connector No.	M18
Connector Name	BCM (BODY CONTROL MODULE)
Connector Color	GRAY



20	19	18	17	16	15	14	13	12	11	10	9	8	7	6	5	4	3	2	1
40	39	38	37	36	35	34	33	32	31	30	29	28	27	26	25	24	23	22	21

Terminal No.	Color of Wire	Signal Name
23	G	O WL AUTHORIZATION RL

Connector No.	M19
Connector Name	BCM (BODY CONTROL MODULE)
Connector Color	BLACK



100	99	98	97	96	95	94	93	92	91	90	89	88	87	86	85	84	83	82	81
120	119	118	117	116	115	114	113	112	111	110	109	108	107	106	105	104	103	102	101

Terminal No.	Color of Wire	Signal Name
95	V	I SHORTING PIN

Connector No.	M20
Connector Name	BCM (BODY CONTROL MODULE)
Connector Color	BROWN



167	166	165	164	163	162	161		
176	175	174	173	172	171	170	169	168

Terminal No.	Color of Wire	Signal Name
161	W	I PWR ECU
170	B	I GND1
171	B	I GND2

Connector No.	M21
Connector Name	WIRE TO WIRE
Connector Color	WHITE



3	2	1		
8	7	6	5	4

Terminal No.	Color of Wire	Signal Name
4	B	-
5	B	-
6	W	-
7	R	-
8	Y	-

Connector No.	M42
Connector Name	CIRCUIT BREAKER-2
Connector Color	WHITE



1	2
---	---

Terminal No.	Color of Wire	Signal Name
1	W	-
2	P	-

Connector No.	M58
Connector Name	POWER WINDOW RELAY
Connector Color	BLUE



3	2	1
5	4	1

Terminal No.	Color of Wire	Signal Name
1	G	-
2	W	-
3	L	-
5	P	-

# MOONROOF SYSTEM

< WIRING DIAGRAM >

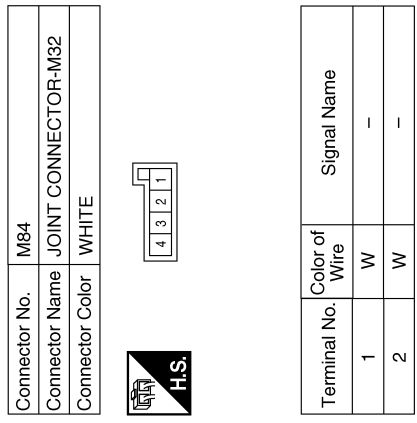
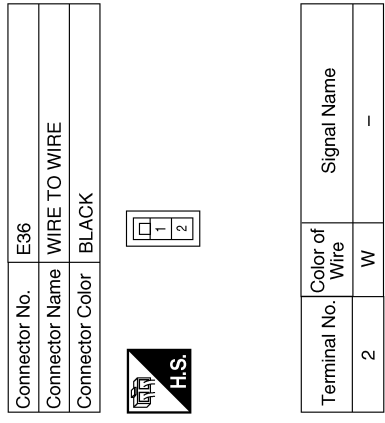
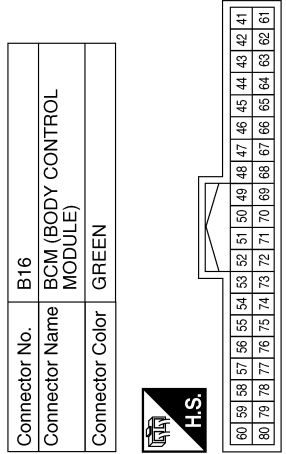
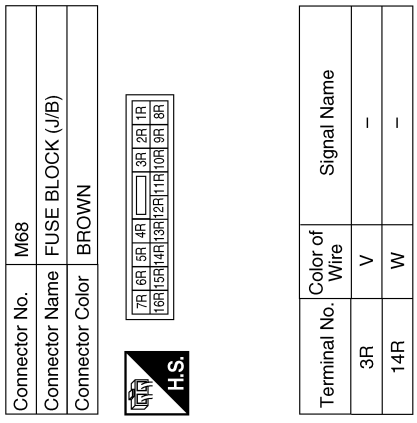
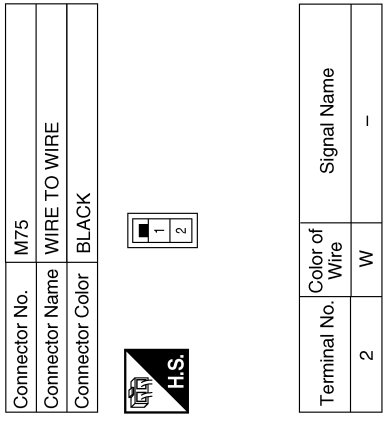
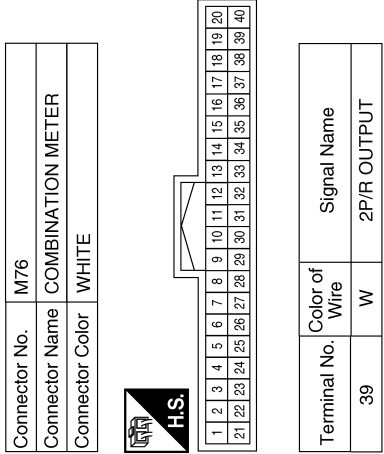

AAKIA1762GB

A  
B  
C  
D  
E  
F  
G  
H  
I  
J  
RF  
L  
M  
N  
O  
P

# MOONROOF SYSTEM

< WIRING DIAGRAM >

Connector No.	B140
Connector Name	WIRE TO WIRE
Connector Color	WHITE

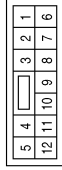

Terminal No.	6	Color of Wire	GR	Signal Name	-
--------------	---	---------------	----	-------------	---

Connector No.	B71
Connector Name	FRONT DOOR SWITCH LH
Connector Color	WHITE

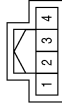

Terminal No.	3	Color of Wire	SB	Signal Name	-
--------------	---	---------------	----	-------------	---

Connector No.	B49
Connector Name	WIRE TO WIRE
Connector Color	WHITE

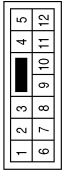

Terminal No.	6	Color of Wire	SB	Signal Name	-
--------------	---	---------------	----	-------------	---

Connector No.	R3
Connector Name	MOONROOF SWITCH
Connector Color	WHITE

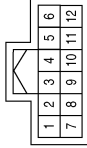

Terminal No.	1	Color of Wire	B	Signal Name	-
	4		G		-
	6		LG		-
	9		W		-
	11		P		-

Connector No.	R1
Connector Name	WIRE TO WIRE
Connector Color	WHITE

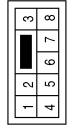

Terminal No.	4	Color of Wire	B	Signal Name	-
	5		B		-
	6		W		-
	7		Y		-
	8		R		-

Connector No.	B141
Connector Name	FRONT DOOR SWITCH RH
Connector Color	WHITE

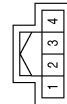

Terminal No.	3	Color of Wire	GR	Signal Name	-
--------------	---	---------------	----	-------------	---

AAKIA1763GB

# MOONROOF SYSTEM

## < WIRING DIAGRAM >

Connector No.	R5
Connector Name	SUNSHADE MOTOR ASSEMBLY
Connector Color	GRAY

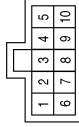

Terminal No.	Color of Wire	Signal Name
1	P	-
3	Y	-
6	V	-
7	GR	-

Terminal No.	Color of Wire	Signal Name
1	B	-
2	BR	-
3	Y	-
4	W	-
5	L	-
6	R	-
7	GR	-
8	G	-
10	LG	-

Connector No.	R4
Connector Name	MOONROOF MOTOR ASSEMBLY
Connector Color	GRAY

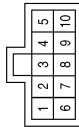

Connector No.	R13
Connector Name	WIRE TO WIRE
Connector Color	WHITE

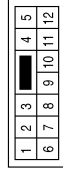

Terminal No.	Color of Wire	Signal Name
1	V	-
2	W	-
3	LG	-
4	G	-
5	Y	-
8	P	-
9	BR	-
10	B	-
11	L	-
12	R	-

Connector No.	R12
Connector Name	WIRE TO WIRE
Connector Color	WHITE

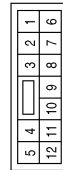

Terminal No.	Color of Wire	Signal Name
1	Y	-
2	P	-
3	W	-
4	W	-
5	R	-
8	B	-
9	LG	-
10	B	-
11	G	-
12	Y	-

AAKIA1764GB

A  
B  
C  
D  
E  
F  
G  
H  
I  
J  
RF  
L  
M  
N  
O  
P

# DIAGNOSIS AND REPAIR WORKFLOW

< BASIC INSPECTION >

## BASIC INSPECTION

### DIAGNOSIS AND REPAIR WORKFLOW

Work Flow

INFOID:000000010247870

#### OVERALL SEQUENCE

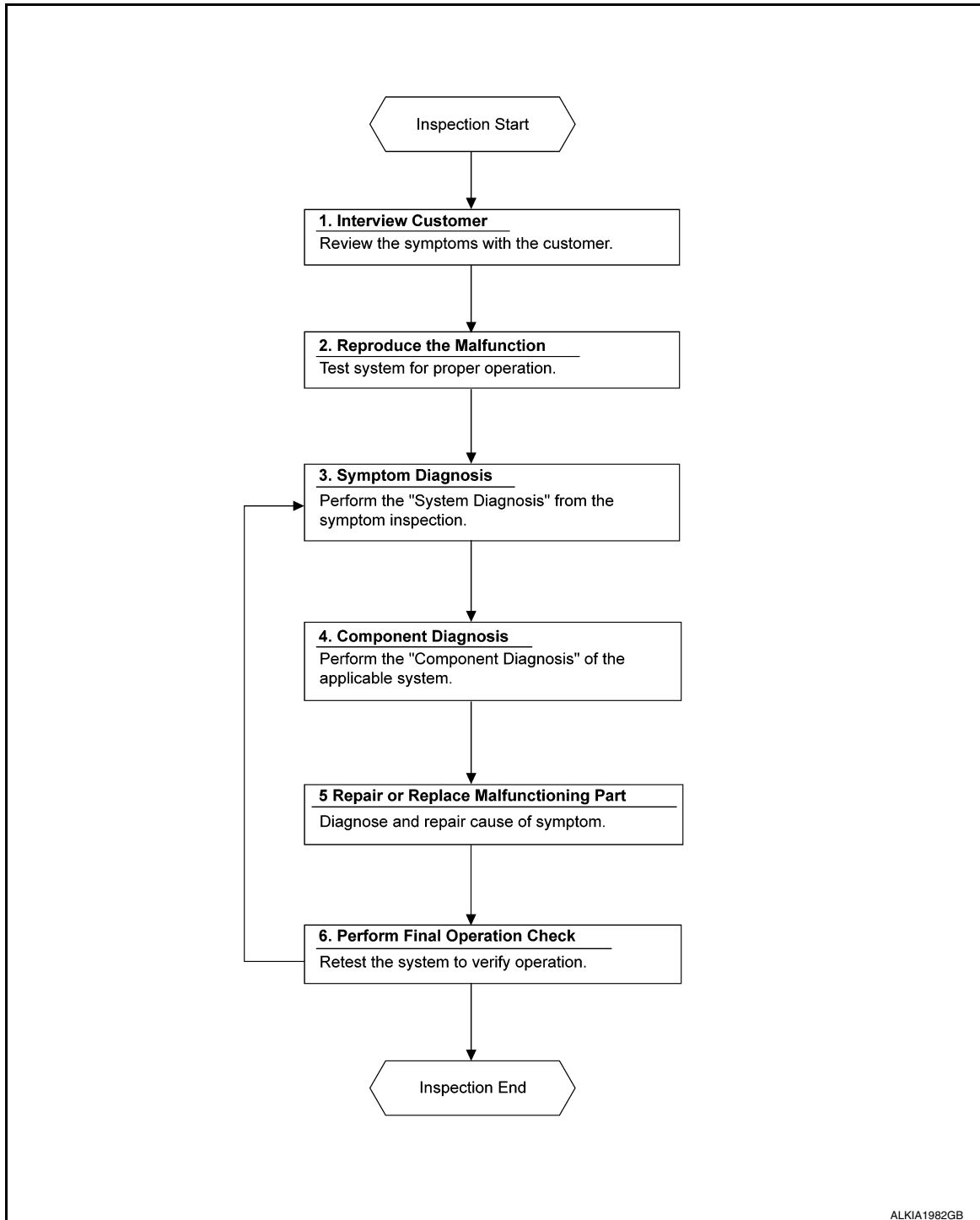

#### DETAILED FLOW

##### 1. OBTAIN INFORMATION ABOUT SYMPTOM

Interview the customer to obtain as much information as possible about the conditions and environment under which the malfunction occurred.

# DIAGNOSIS AND REPAIR WORKFLOW

< BASIC INSPECTION >

---

>> GO TO 2.

## 2. CONFIRM CONCERN

---

Check the malfunction on the vehicle that the customer describes.  
Inspect the relation of the symptoms and the condition when the symptoms occur.

>> GO TO 3.

## 3. IDENTIFY THE MALFUNCTIONING SYSTEM WITH SYMPTOM DIAGNOSIS

---

Use Symptom diagnosis from the symptom inspection result in step 2 and then identify where to start performing the diagnosis based on possible causes and symptoms.

>> GO TO 4.

## 4. PERFORM THE COMPONENT DIAGNOSIS OF THE APPLICABLE SYSTEM

---

Perform the diagnosis with Component diagnosis of the applicable system.

>> GO TO 5.

## 5. REPAIR OR REPLACE THE MALFUNCTIONING PARTS

---

Repair or replace the specified malfunctioning parts.

>> GO TO 6.

## 6. FINAL CHECK

---

Check that malfunctions are not reproduced when obtaining the malfunction information from the customer, referring to the symptom inspection result in step 2.

Are the malfunctions corrected?

YES >> Inspection End.

NO >> GO TO 3.

A  
B  
C  
D  
E  
F  
G  
H  
I  
J  
RF  
L  
M  
N  
O  
P

# INSPECTION AND ADJUSTMENT

< BASIC INSPECTION >

---

## INSPECTION AND ADJUSTMENT

### ADDITIONAL SERVICE WHEN REPLACING CONTROL UNIT

ADDITIONAL SERVICE WHEN REPLACING CONTROL UNIT : Special Repair Requirement

INFOID:000000010282994

### INITIALIZATION PROCEDURE

#### Moonroof

If the moonroof does not open or close automatically, use the following procedure to return moonroof operation to normal.

1. Turn ignition switch ON.
2. Push and hold the moonroof switch forward until the moonroof and sunshade stop and bounce back.
3. Release the moonroof switch.
4. Press and hold the moonroof switch within 6 seconds.
5. The roof glass and shade will move to full open and back to full close.
6. Release the switch, initialization is complete if the moonroof operates normally.

### ANTI-PINCH FUNCTION

#### Moonroof/Sunshade

1. Fully open the moonroof to the full open position.
2. Place a piece of wood at the fully closed position.
3. Close the moonroof completely with auto-slide close function.
4. Moonroof should make contact and then tilt up or travel in reverse.

#### **CAUTION:**

- Do not test the anti-pinch function with your hands or other body parts because they may be pinched.
- Depending on the environment and driving conditions, if a similar impact or load is applied to the moonroof it may lower.
- Test the auto-slide operation before inspection when the initialization procedure is performed.
- Perform the initialization procedure when the auto-slide operation or anti-pinch function does not operate normally.



# POWER SUPPLY AND GROUND CIRCUIT

< DTC/CIRCUIT DIAGNOSIS >

## DTC/CIRCUIT DIAGNOSIS

### POWER SUPPLY AND GROUND CIRCUIT

#### BCM (BODY CONTROL SYSTEM) (WITH INTELLIGENT KEY SYSTEM)

#### BCM (BODY CONTROL SYSTEM) (WITH INTELLIGENT KEY SYSTEM) : Diagnosis Procedure

INFOID:000000010377886

Regarding Wiring Diagram information, refer to [BCS-50. "Wiring Diagram"](#).

### 1. CHECK FUSE

Check that the following fuse is not blown.

Terminal No.	Signal name	Fuse No.
161	BCM power supply	7 (10A)

#### Is the fuse blown?

- YES >> Replace the blown fuse after repairing the affected circuit.
- NO >> GO TO 2.

### 2. CHECK POWER SUPPLY CIRCUIT

1. Disconnect BCM connector M20.
2. Check voltage between BCM connector M20 and ground.

BCM		Ground	Voltage (Approx.)
Connector	Terminal		
M20	161	—	Battery voltage

#### Is the inspection result normal?

- YES >> GO TO 3.
- NO >> Repair or replace harness or connectors.

### 3. CHECK GROUND CIRCUIT

Check continuity between BCM connector M20 and ground.

BCM		Ground	Continuity
Connector	Terminal		
M20	170	—	Yes
	171		

#### Is the inspection result normal?

- YES >> Inspection End.
- NO >> Repair or replace harness or connectors.

### BCM (BODY CONTROL SYSTEM) (WITHOUT INTELLIGENT KEY SYSTEM)

#### BCM (BODY CONTROL SYSTEM) (WITHOUT INTELLIGENT KEY SYSTEM) : Diagnosis Procedure

INFOID:000000010377887

Regarding Wiring Diagram information, refer to [BCS-110. "Wiring Diagram"](#).

### 1. CHECK FUSE

# POWER SUPPLY AND GROUND CIRCUIT

## < DTC/CIRCUIT DIAGNOSIS >

Check that the following fuse is not blown.

Terminal No.	Signal name	Fuse No.
161	BCM power supply	7 (10A)

### Is the fuse blown?

- YES >> Replace the blown fuse after repairing the affected circuit.  
NO >> GO TO 2.

## 2. CHECK POWER SUPPLY CIRCUIT

1. Disconnect BCM connector M20.
2. Check voltage between BCM connector M20 and ground.

BCM		Ground	Voltage (Approx.)
Connector	Terminal		
M20	161	—	Battery voltage

### Is the inspection result normal?

- YES >> GO TO 3.  
NO >> Repair or replace harness or connectors.

## 3. CHECK GROUND CIRCUIT

Check continuity between BCM connector M20 and ground.

BCM		Ground	Continuity
Connector	Terminal		
M20	170	—	Yes
	171		

### Is the inspection result normal?

- YES >> Inspection End.  
NO >> Repair or replace harness or connectors.

## MOONROOF MOTOR ASSEMBLY

### MOONROOF MOTOR ASSEMBLY : Description

INFOID:000000010301061

- BCM supplies the moonroof motor assembly with power.
- CPU is integrated in moonroof motor assembly.
- Tilts up/down & slides open/close by moonroof switch operation.
- In order to close the moonroof during high speed driving, the Combination meter will send a speed signal to the moonroof CPU to adjust the torque of the motor during the tilt-down operation.

### MOONROOF MOTOR ASSEMBLY : Component Function Check

INFOID:000000010301062

## 1. CHECK MOONROOF MOTOR FUNCTION

Does the tilt up/down & slide open/close functions operate normally with moonroof switch?

### Is the inspection result normal?

- YES >> Moonroof motor assembly is OK.  
NO >> Refer to [RF-26, "MOONROOF MOTOR ASSEMBLY : Diagnosis Procedure"](#).

## MOONROOF MOTOR ASSEMBLY : Diagnosis Procedure

INFOID:000000010301063

Regarding Wiring Diagram information, refer to [RF-17, "Wiring Diagram"](#).

# POWER SUPPLY AND GROUND CIRCUIT

## < DTC/CIRCUIT DIAGNOSIS >

### MOONROOF MOTOR ASSEMBLY

#### 1. CHECK POWER SUPPLY CIRCUIT

1. Turn ignition switch OFF.
2. Disconnect the moonroof motor assembly connector.
3. Turn ignition switch ON.
4. Check voltage between moonroof motor assembly connector and ground.

Terminal		Voltage (Approx.)
(+)	(-)	
Moonroof motor assembly connector	Terminal	Battery voltage
R4	3 6	

Is the inspection result normal?

YES >> GO TO 2.

NO >> GO TO 3.

#### 2. CHECK GROUND CIRCUIT

1. Turn ignition switch OFF.
2. Check continuity between moonroof motor assembly connector and ground.

Moonroof motor assembly connector	Terminal	Ground	Continuity
R4	1		Yes

Is the inspection result normal?

YES >> GO TO 5.

NO >> Repair or replace harness.

#### 3. CHECK HARNESS CONTINUITY

1. Turn ignition switch OFF.
2. Disconnect power window relay connector.
3. Check continuity between power window relay harness connector and moonroof motor assembly harness connector.

Power window relay		Main power window and door lock/unlock switch		Continuity
Connector	Terminal	Connector	Terminal	
M58	3	R4	3	Yes

4. Check continuity between power window relay harness connector and ground.

Power window relay		Ground	Continuity
Connector	Terminal		
M58	3		No

Is the inspection result normal?

YES >> Refer to [PWC-48. "Diagnosis Procedure"](#).

NO >> Repair or replace harness.

#### 4. CHECK MOONROOF SWITCH INPUT SIGNAL

1. Connect moonroof motor assembly.
2. Turn ignition switch ON.
3. Check voltage between the moonroof motor assembly connector and ground.

Moonroof motor assembly connector	Terminals		Condition	Voltage (Approx.)
	(+)	(-)		

# POWER SUPPLY AND GROUND CIRCUIT

## < DTC/CIRCUIT DIAGNOSIS >

R4	5	Ground	Moonroof switch is operated TILT DOWN or SLIDE OPEN	0
			Other than above	Battery voltage
	10		Moonroof switch is operated TILT UP or SLIDE CLOSE	0
			Other than above	Battery voltage

Is the inspection result normal?

YES >> GO TO 8.

NO >> GO TO 6.

### 5. CHECK MOONROOF SWITCH CIRCUIT

1. Turn ignition switch OFF.
2. Disconnect the moonroof motor assembly and moonroof switch.
3. Check continuity between the moonroof motor assembly connector and moonroof switch connector.

Moonroof motor assembly connector	Terminal	Moonroof switch connector	Terminal	Continuity
R4	5	R3	4	Yes
	10		9	

4. Check continuity between the moonroof motor assembly connector and ground.

Moonroof motor assembly connector	Terminal	Ground	Continuity
R4	5	Ground	No
	10		

Is the inspection result normal?

YES >> GO TO 7.

NO >> Repair or replace harness.

### 6. CHECK MOONROOF SWITCH GROUND CIRCUIT

1. Connect moonroof motor assembly.
2. Check continuity between the moonroof switch connector and ground.

Moonroof switch connector	Terminal	Ground	Continuity
R3	1	Ground	Yes

Is the inspection result normal?

YES >> Refer to [RF-32, "Component Inspection"](#).

NO >> Repair or replace harness.

### 7. CHECK COMBINATION METER SIGNAL

1. Connect the moonroof motor assembly connector.
2. Turn ignition switch ON.
3. Check the signal between the moonroof motor assembly connector and ground with oscilloscope.

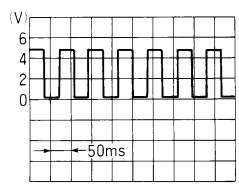
Terminals		Condition	Signal (Reference value)
(+)	(-)		
Moonroof motor assembly connector	Terminal	Speedometer operated [When vehicle speed is approx.40km/h (25MPH)]	
R4	8		

# POWER SUPPLY AND GROUND CIRCUIT

## < DTC/CIRCUIT DIAGNOSIS >

### Is the inspection result normal?

- YES >> Replace moonroof motor assembly. Refer to [RF-53, "Removal and Installation"](#). After that, refer to [RF-24, "ADDITIONAL SERVICE WHEN REPLACING CONTROL UNIT : Special Repair Requirement"](#).
- NO >> GO TO 9.

## 8. CHECK COMBINATION METER CIRCUIT

1. Turn ignition switch OFF.
2. Disconnect combination meter.
3. Check continuity between the combination meter connector and the moonroof motor assembly connector.

Combination meter connector	Terminal	Moonroof motor assembly connector	Terminal	Continuity
M76	39	R4	8	Yes

4. Check continuity between the combination meter connector and ground.

Combination meter connector	Terminal	Ground	Continuity
M76	39		No

### Is the inspection result normal?

- YES >> Replace combination meter. Refer to [BCS-76, "Removal and Installation"](#).
- NO >> Repair or replace harness.

## MOONROOF MOTOR ASSEMBLY : Special Repair Requirement

INFOID:0000000010301064

### 1. PERFORM INITIALIZATION PROCEDURE

Perform the initialization procedure.

Refer to [RF-29, "MOONROOF MOTOR ASSEMBLY : Special Repair Requirement"](#).

>> GO TO 2.

### 2. CHECK ANTI-PINCH OPERATION

Check the anti-pinch operation.

Refer to [RF-29, "MOONROOF MOTOR ASSEMBLY : Special Repair Requirement"](#).

### Is the inspection result normal?

- YES >> Inspection End.
- NO >> Check fitting adjustment.

## SUNSHADE MOTOR ASSEMBLY

### SUNSHADE MOTOR ASSEMBLY : Description

INFOID:0000000010306816

- BCM supplies the sunshade motor assembly with power.
- CPU is integrated in sunshade motor assembly.
- Slide open/close controlled by the moonroof switch operation.

### SUNSHADE MOTOR ASSEMBLY : Component Function Check

INFOID:0000000010306817

#### 1. CHECK SUNSHADE MOTOR FUNCTION

Does the slide open and close functions operate normally with the moonroof switch?

### Is the inspection result normal?

- YES >> Sunshade motor assembly is OK.
- NO >> Refer to [RF-29, "SUNSHADE MOTOR ASSEMBLY : Diagnosis Procedure"](#).

### SUNSHADE MOTOR ASSEMBLY : Diagnosis Procedure

INFOID:0000000010306818

Regarding Wiring Diagram information, refer to [RF-17, "Wiring Diagram"](#).

# POWER SUPPLY AND GROUND CIRCUIT

## < DTC/CIRCUIT DIAGNOSIS >

### 1. CHECK POWER SUPPLY

1. Turn ignition switch OFF.
2. Disconnect sunshade motor assembly connector.
3. Turn ignition switch ON.
4. Check voltage between sunshade motor assembly harness connector and ground.

(+)		(-)	Voltage (Approx.)
Sunshade motor assembly			
Connector	Terminal		
R5	3	Ground	Battery voltage

Is the inspection result normal?

YES >> GO TO 2.

NO >> GO TO 3.

### 2. CHECK GROUND CIRCUIT

1. Turn ignition switch OFF.
2. Check continuity between sunshade motor assembly harness connector and ground.

Sunshade motor assembly		Ground	Continuity
Connector	Terminal		
R5	1		Yes

Is the inspection result normal?

YES >> GO TO 4.

NO >> Repair or replace the harness.

### 3. CHECK HARNESS CONTINUITY

1. Turn ignition switch OFF.
2. Disconnect power window relay connector.
3. Check continuity between power window relay harness connector and moonroof motor assembly harness connector.

Power window relay		Moonroof motor assembly		Continuity
Connector	Terminal	Connector	Terminal	
M58	3	R4	3	Yes

4. Check continuity between power window relay harness connector and ground.

Power window relay		Ground	Continuity
Connector	Terminal		
M58	3		No

Is the inspection result normal?

YES >> Refer to [PWC-48. "Diagnosis Procedure"](#).

NO >> Repair or replace harness.

# MOONROOF SWITCH

< DTC/CIRCUIT DIAGNOSIS >

## MOONROOF SWITCH

### Description

INFOID:000000010247880

Transmits switch operation signal to moonroof motor and sunshade motor assembly.

### Diagnosis Procedure

INFOID:000000010247881

Regarding Wiring Diagram information, refer to [RF-17, "Wiring Diagram"](#).

## 1. CHECK MOONROOF SWITCH INPUT SIGNAL

1. Turn ignition switch ON.
2. Check voltage between moonroof motor assembly harness connector and ground.

(+)		(-)	Condition	Voltage (Approx.)
Moonroof motor assembly				
Connector	Terminals			
R4	5	Ground	Moonroof switch is operated OPEN (1st)	0
			Other than above	Battery voltage
	10		Moonroof switch is operated CLOSE (2nd)	0
			Other than above	Battery voltage
	2		Moonroof switch is operated OPEN (2nd click to open sunshade)	0
			Other than above	Battery voltage
	2		Moonroof switch is operated CLOSE (2nd click to close sunshade)	0
			Other than above	Battery voltage

Is the inspection result normal?

YES >> Inspection End.

NO >> GO TO 2.

## 2. CHECK MOONROOF SWITCH CIRCUIT

1. Turn ignition switch OFF.
2. Disconnect moonroof motor assembly connector and moonroof switch connector.
3. Check continuity between moonroof motor assembly harness connector and moonroof switch harness connector.

Moonroof motor assembly		Moonroof switch		Continuity
Connector	Terminal	Connector	Terminal	
R4	2	R3	6	Yes
	4		11	
	5		4	
	10		9	

4. Check continuity between moonroof motor assembly harness connector and ground.

# MOONROOF SWITCH

## < DTC/CIRCUIT DIAGNOSIS >

Moonroof motor assembly			Continuity
Connector	Terminal		
R4	2	Ground	No
	4		
	5		
	10		

Is the inspection result normal?

YES >> GO TO 3.

NO >> Repair or replace the harness.

### 3. CHECK MOONROOF SWITCH GROUND CIRCUIT

Check continuity between moonroof switch harness connector and ground.

Moonroof switch			Continuity
Connector	Terminal		
R3	1	Ground	Yes

Is the inspection result normal?

YES >> GO TO 4.

NO >> Repair or replace the harness.

### 4. CHECK MOONROOF SWITCH

Check moonroof switch.

Refer to [RF-32, "Component Inspection"](#).

Is the inspection result normal?

YES >> GO TO 5.

NO >> Replace moonroof switch. Refer to [RF-64, "Removal and Installation"](#).

### 5. CHECK INTERMITTENT INCIDENT

Refer to [GI-41, "Intermittent Incident"](#).

>> Inspection End.

## Component Inspection

INFOID:0000000010247882

### MOONROOF SWITCH

#### 1. CHECK MOONROOF SWITCH

1. Turn ignition switch OFF.
2. Disconnect moonroof switch.
3. Check continuity between moonroof switch terminals.

Terminals	Condition	Continuity
4	Moonroof switch is operated - OPEN	Yes
	Other than above	No
9	Moonroof switch is operated - CLOSE	Yes
	Other than above	No
6	Moonroof switch is operated - HOLD OPEN or HOLD CLOSE	Yes
	Other than above	No
11	Moonroof switch is operated - HOLD OPEN or HOLD CLOSE	Yes
	Other than above	No

Is the inspection result normal?

YES >> Moonroof switch is OK.



# MOONROOF SWITCH

## < DTC/CIRCUIT DIAGNOSIS >

---

NO >> Replace moonroof switch. Refer to [RF-64. "Removal and Installation"](#).

A

B

C

D

E

F

G

H

I

J

**RF**

L

M

N

O

P

# DOOR SWITCH

< DTC/CIRCUIT DIAGNOSIS >

## DOOR SWITCH WITH INTELLIGENT KEY

### WITH INTELLIGENT KEY : Component Function Check

INFOID:0000000010377888

#### 1. CHECK FUNCTION

1. Select "DOOR LOCK" of "BCM" using CONSULT.
2. Select "DOOR SW-DR", "DOOR SW-AS", "DOOR SW-RL", "DOOR SW-RR", in "Data Monitor" mode.
3. Check that the function operates normally according to the following conditions.

Monitor item	Condition		Status
DOOR SW-DR	Driver side door	Open	On
		Closed	Off
DOOR SW-AS	Passenger side door	Open	On
		Closed	Off
DOOR SW-RL	Rear door LH	Open	On
		Closed	Off
DOOR SW-RR	Rear door RH	Open	On
		Closed	Off

Is the inspection result normal?

YES >> Door switch is OK.

NO >> Refer to [RF-34, "WITH INTELLIGENT KEY : Diagnosis Procedure"](#).

### WITH INTELLIGENT KEY : Diagnosis Procedure

INFOID:0000000010377889

Regarding Wiring Diagram information, refer to [DLK-69, "Wiring Diagram"](#).

#### 1. CHECK DOOR SWITCH INPUT SIGNAL

1. Turn ignition switch OFF.
2. Disconnect malfunctioning door switch connector.
3. Check signal between malfunctioning door switch harness connector and ground using oscilloscope.

(+)		Terminal	(-)	Signal (Reference value)
Door switch				
Connector				
Driver side	B71	3	Ground	
Passenger side	B141			
Rear LH	B70			
Rear RH	B142			

Is the inspection result normal?

YES >> GO TO 3.

NO >> GO TO 2.

#### 2. CHECK DOOR SWITCH CIRCUIT

1. Disconnect BCM connector.
2. Check continuity between door switch harness connector and BCM harness connector.

# DOOR SWITCH

## < DTC/CIRCUIT DIAGNOSIS >

Door switch		BCM		Continuity
Connector	Terminal	Connector	Terminal	
Front LH	B71	3	B16	Yes
Front RH	B141			
Rear LH	B70			
Rear RH	B142			

3. Check continuity between door switch harness connector and ground.

Door switch		Ground	Continuity
Connector	Terminal		
Front LH	B71	3	No
Front RH	B141		
Rear LH	B70		
Rear RH	B142		

Is the inspection result normal?

YES >> Replace BCM. Refer to [BCS-75, "Removal and Installation"](#).

NO >> Repair or replace harness.

### 3.CHECK DOOR SWITCH

Refer to [RF-35, "WITH INTELLIGENT KEY : Component Inspection"](#).

Is the inspection result normal?

YES >> GO TO 4.

NO >> Replace malfunctioning door switch. Refer to [DLK-269, "Removal and Installation"](#).

### 4.CHECK INTERMITTENT INCIDENT

Refer to [GI-41, "Intermittent Incident"](#).

>> Inspection End.

## WITH INTELLIGENT KEY : Component Inspection

INFOID:000000010377890

RF

### 1.CHECK DOOR SWITCH

1. Turn ignition switch OFF.
2. Disconnect malfunctioning door switch connector.
3. Check continuity between door switch terminals.

Door switch		Condition		Continuity
Terminal		Door switch		
3	Ground contact is part of the switch.		Pressed	No
		Released	Yes	

Is the inspection result normal?

YES >> Inspection End.

NO >> Replace malfunctioning door switch. Refer to [DLK-269, "Removal and Installation"](#).

## WITHOUT INTELLIGENT KEY

### WITHOUT INTELLIGENT KEY : Description

INFOID:000000010377891

Detects door open/close condition.

### WITHOUT INTELLIGENT KEY : Component Function Check

INFOID:000000010377892

### 1.CHECK FUNCTION

# DOOR SWITCH

## < DTC/CIRCUIT DIAGNOSIS >

1. Select "DOOR LOCK" of BCM using CONSULT.
2. Select "DOOR SW-DR", "DOOR SW-AS", "DOOR SW-RL", "DOOR SW-RR", in Data Monitor mode.
3. Check that the function operates normally according to the following conditions.

Monitor item	Condition		Status
DOOR SW-DR	Driver side door	Open	On
		Closed	Off
DOOR SW-AS	Passenger side door	Open	On
		Closed	Off
DOOR SW-RL	Rear door LH	Open	On
		Closed	Off
DOOR SW-RR	Rear door RH	Open	On
		Closed	Off

Is the inspection result normal?

YES >> Door switch is OK.

NO >> Refer to [RF-36, "WITHOUT INTELLIGENT KEY : Diagnosis Procedure"](#).

## WITHOUT INTELLIGENT KEY : Diagnosis Procedure

INFOID:000000010377893

Regarding Wiring Diagram information, refer to [DLK-293, "Wiring Diagram"](#).

### 1. CHECK DOOR SWITCH INPUT SIGNAL

1. Turn ignition switch OFF.
2. Disconnect malfunctioning door switch connector.
3. Check signal between malfunctioning door switch harness connector and ground using oscilloscope.

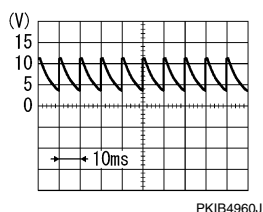
(+)		Terminal	(-)	Signal (Reference value)
Door switch				
Connector				
Front LH	B71	3	Ground	
Front RH	B141			
Rear LH	B70			
Rear RH	B142			

Is the inspection result normal?

YES >> GO TO 3.

NO >> GO TO 2.

### 2. CHECK DOOR SWITCH CIRCUIT

1. Disconnect BCM connector.
2. Check continuity between door switch harness connector and BCM harness connector.

# DOOR SWITCH

## < DTC/CIRCUIT DIAGNOSIS >

Door switch		BCM		Continuity
Connector	Terminal	Connector	Terminal	
Front LH	B71	3	B16	Yes
Front RH	B141			
Rear LH	B70			
Rear RH	B142			

3. Check continuity between door switch harness connector and ground.

Door switch		Ground	Continuity
Connector	Terminal		
Front LH	B71	3	No
Front RH	B141		
Rear LH	B70		
Rear RH	B142		

Is the inspection result normal?

YES >> Replace BCM. Refer to [BCS-135, "Removal and Installation"](#).

NO >> Repair or replace harness.

### 3.CHECK DOOR SWITCH

Refer to [RF-35, "WITH INTELLIGENT KEY : Component Inspection"](#).

Is the inspection result normal?

YES >> GO TO 4.

NO >> Replace malfunctioning door switch. Refer to [DLK-385, "Removal and Installation"](#).

### 4.CHECK INTERMITTENT INCIDENT

Refer to [GI-41, "Intermittent Incident"](#).

>> Inspection End.

## WITHOUT INTELLIGENT KEY : Component Inspection

INFOID:000000010377894

RF

### 1.CHECK DOOR SWITCH

1. Turn ignition switch OFF.
2. Disconnect door switch connector.
3. Check door switch.

Terminal		Door switch condition	Continuity
Door switch			
3	Ground part of door switch	Pressed	No
		Released	Yes

Is the inspection result normal?

YES >> Inspection End.

NO >> Replace malfunctioning door switch. Refer to [DLK-385, "Removal and Installation"](#).

# MOONROOF DOES NOT OPERATE PROPERLY

< SYMPTOM DIAGNOSIS >

---

## SYMPTOM DIAGNOSIS

### MOONROOF DOES NOT OPERATE PROPERLY

#### Diagnosis Procedure

INFOID:0000000010247889

#### 1. CHECK BCM POWER SUPPLY AND GROUND CIRCUIT

---

Check BCM power supply and ground circuit.

Refer to [BCS-68, "Diagnosis Procedure"](#) (with Intelligent Key System), [BCS-128, "Diagnosis Procedure"](#) (without Intelligent Key System)

Is the inspection result normal?

YES >> GO TO 2.

NO >> Repair or replace malfunctioning parts.

#### 2. CHECK MOONROOF MOTOR ASSEMBLY POWER SUPPLY AND GROUND CIRCUIT

---

Check moonroof motor assembly power supply and ground circuit.

Refer to [RF-38, "Diagnosis Procedure"](#).

Is the inspection result normal?

YES >> Check intermittent incident. Refer to [GI-41, "Intermittent Incident"](#).

NO >> Repair or replace malfunctioning parts.

# SUNSHADE SYSTEM DOES NOT OPERATE PROPERLY

< SYMPTOM DIAGNOSIS >

## SUNSHADE SYSTEM DOES NOT OPERATE PROPERLY

### Diagnosis Procedure

INFOID:000000010247890

#### 1.CHECK BCM POWER SUPPLY AND GROUND CIRCUIT

Check BCM power supply and ground circuit.

Refer to [BCS-68. "Diagnosis Procedure"](#) (with Intelligent Key System), [BCS-128. "Diagnosis Procedure"](#) (without Intelligent Key System).

Is the inspection result normal?

YES >> GO TO 2.

NO >> Repair or replace the malfunctioning parts.

#### 2.CHECK SUNSHADE MOTOR ASSEMBLY POWER SUPPLY AND GROUND CIRCUIT

Check sunshade motor assembly power supply and ground circuit.

Refer to [RF-29. "SUNSHADE MOTOR ASSEMBLY : Diagnosis Procedure"](#).

Is the inspection result normal?

YES >> GO TO 3.

NO >> Repair or replace the malfunctioning parts.

#### 3.CONFIRM THE OPERATION

Confirm the operation again.

Is the result normal?

YES >> Check intermittent incident. Refer to [GI-41. "Intermittent Incident"](#).

NO >> GO TO 1.

A  
B  
C  
D  
E  
F  
G  
H  
I  
J  
L  
M  
N  
O  
P

RF

# AUTO OPERATION DOES NOT OPERATE

< SYMPTOM DIAGNOSIS >

---

## AUTO OPERATION DOES NOT OPERATE MOONROOF

### MOONROOF : Diagnosis Procedure

INFOID:000000010247891

#### 1. PERFORM INITIALIZATION PROCEDURE

---

Perform initialization procedure.

Refer to [RF-24, "ADDITIONAL SERVICE WHEN REPLACING CONTROL UNIT : Special Repair Requirement"](#).

Is the inspection result normal?

YES >> Moonroof system is normal.

NO >> GO TO 2.

#### 2. CHECK MOONROOF SWITCH

---

Check moonroof switch.

Refer to [RF-31, "Diagnosis Procedure"](#).

Is the inspection result normal?

YES >> GO TO 3.

NO >> Repair or replace the malfunctioning parts.

#### 3. CONFIRM THE OPERATION

---

Confirm the operation again.

Is the inspection result normal?

YES >> Check intermittent incident. Refer to [GI-41, "Intermittent Incident"](#).

NO >> GO TO 1.

## SUNSHADE

### SUNSHADE : Diagnosis Procedure

INFOID:000000010247892

#### 1. PERFORM INITIALIZATION PROCEDURE

---

Refer to [RF-24, "ADDITIONAL SERVICE WHEN REPLACING CONTROL UNIT : Special Repair Requirement"](#).

Is the inspection result normal?

YES >> Sunshade system is normal.

NO >> GO TO 2.

#### 2. CHECK MOONROOF SWITCH

---

Check moonroof switch.

Refer to [RF-31, "Diagnosis Procedure"](#).

Is the inspection result normal?

YES >> GO TO 3.

NO >> Repair or replace the malfunctioning parts.

#### 3. CONFIRM THE OPERATION

---

Confirm the operation again.

Is the result normal?

YES >> Check intermittent incident. Refer to [GI-41, "Intermittent Incident"](#).

NO >> GO TO 1.



# ANTI-PINCH FUNCTION DOES NOT OPERATE

< SYMPTOM DIAGNOSIS >

## ANTI-PINCH FUNCTION DOES NOT OPERATE

### MOONROOF

#### MOONROOF : Diagnosis Procedure

INFOID:000000010247893

#### 1. PERFORM INITIALIZATION PROCEDURE

Perform initialization procedure.

Refer to [RF-24, "ADDITIONAL SERVICE WHEN REPLACING CONTROL UNIT : Special Repair Requirement"](#).

Is the inspection result normal?

YES >> GO TO 2.

NO >> Perform basic inspection. Refer to [RF-22, "Work Flow"](#).

#### 2. RETEST THE ANTI-PINCH FUNCTION

Check anti-pinch operation. Refer to [RF-24, "ADDITIONAL SERVICE WHEN REPLACING CONTROL UNIT : Special Repair Requirement"](#).

Is the inspection result normal?

YES >> Inspection End.

NO >> Replace the moonroof motor assembly. Refer to [RF-53, "Removal and Installation"](#).

### SUNSHADE

#### SUNSHADE : Diagnosis Procedure

INFOID:000000010247894

#### 1. CHECK SUNSHADE MECHANISM

Check the following:

- Operation malfunction caused by sunshade mechanism deformation, pinched harness or other foreign materials
- Operation malfunction and interference with other parts by poor installation

Is the inspection result normal?

YES >> GO TO 2.

NO >> Repair or replace the malfunctioning parts.

#### 2. PERFORM INITIALIZATION PROCEDURE

Perform anti-pinch procedure.

Refer to [RF-24, "ADDITIONAL SERVICE WHEN REPLACING CONTROL UNIT : Special Repair Requirement"](#).

Is the inspection result normal?

YES >> GO TO 3.

NO >> GO TO 1.

#### 3. RETEST THE ANTI-PINCH FUNCTION

Check anti-pinch operation. Refer to [RF-24, "ADDITIONAL SERVICE WHEN REPLACING CONTROL UNIT : Special Repair Requirement"](#).

Is the inspection result normal?

YES >> Inspection End.

NO >> Replace the sunshade motor assembly. Refer to [RF-62, "Removal and Installation"](#).

A  
B  
C  
D  
E  
F  
G  
H  
I  
J  
RF  
L  
M  
N  
O  
P

# RETAINED POWER OPERATION DOES NOT OPERATE PROPERLY

< SYMPTOM DIAGNOSIS >

---

## RETAINED POWER OPERATION DOES NOT OPERATE PROPERLY

### Diagnosis Procedure

INFOID:000000010247895

#### 1. CHECK FRONT DOOR SWITCH

---

Check (LH and RH) front door switches.  
Refer to [DLK-24. "Front Door Switch"](#).

Is the inspection result normal?

YES >> GO TO 2.

NO >> Repair or replace the malfunctioning parts.

#### 2. CONFIRM THE OPERATION

---

Confirm the operation again.

Is the inspection result normal?

YES >> Check intermittent incident. Refer to [GI-41. "Intermittent Incident"](#).

NO >> GO TO 1.

# SQUEAK AND RATTLE TROUBLE DIAGNOSES

< SYMPTOM DIAGNOSIS >

## SQUEAK AND RATTLE TROUBLE DIAGNOSES

### Work Flow

INFOID:000000010308755

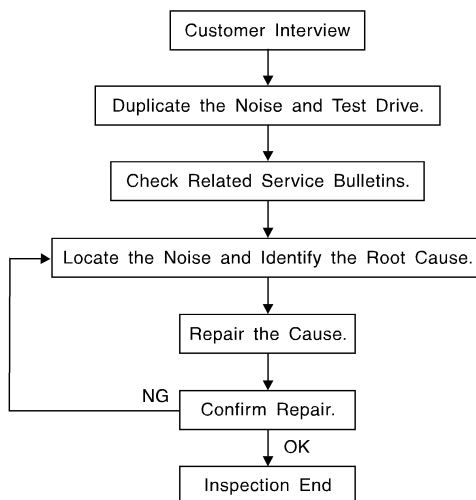

SBT842

### CUSTOMER INTERVIEW

Interview the customer if possible, to determine the conditions that exist when the noise occurs. Use the Diagnostic Worksheet during the interview to document the facts and conditions when the noise occurs and any customer's comments; refer to [RF-47, "Diagnostic Worksheet"](#). This information is necessary to duplicate the conditions that exist when the noise occurs.

- The customer may not be able to provide a detailed description or the location of the noise. Attempt to obtain all the facts and conditions that exist when the noise occurs (or does not occur).
- If there is more than one noise in the vehicle, be sure to diagnose and repair the noise that the customer is concerned about. This can be accomplished by test driving the vehicle with the customer.
- After identifying the type of noise, isolate the noise in terms of its characteristics. The noise characteristics are provided so the customer, service adviser and technician are all speaking the same language when defining the noise.
- Squeak —(Like tennis shoes on a clean floor)  
Squeak characteristics include the light contact/fast movement/brought on by road conditions/hard surfaces = higher pitch noise/softer surfaces = lower pitch noises/edge to surface = chirping.
- Creak—(Like walking on an old wooden floor)  
Creak characteristics include firm contact/slow movement/twisting with a rotational movement/pitch dependent on materials/often brought on by activity.
- Rattle—(Like shaking a baby rattle)  
Rattle characteristics include the fast repeated contact/vibration or similar movement/loose parts/missing clip or fastener/incorrect clearance.
- Knock —(Like a knock on a door)  
Knock characteristics include hollow sounding/sometimes repeating/often brought on by driver action.
- Tick—(Like a clock second hand)  
Tick characteristics include gentle contacting of light materials/loose components/can be caused by driver action or road conditions.
- Thump—(Heavy, muffled knock noise)  
Thump characteristics include softer knock/dead sound often brought on by activity.
- Buzz—(Like a bumble bee)  
Buzz characteristics include high frequency rattle/firm contact.
- Often the degree of acceptable noise level will vary depending upon the person. A noise that you may judge as acceptable may be very irritating to the customer.
- Weather conditions, especially humidity and temperature, may have a great effect on noise level.

### DUPLICATE THE NOISE AND TEST DRIVE

If possible, drive the vehicle with the customer until the noise is duplicated. Note any additional information on the Diagnostic Worksheet regarding the conditions or location of the noise. This information can be used to duplicate the same conditions when you confirm the repair.

# SQUEAK AND RATTLE TROUBLE DIAGNOSES

## < SYMPTOM DIAGNOSIS >

If the noise can be duplicated easily during the test drive, to help identify the source of the noise, try to duplicate the noise with the vehicle stopped by doing one or all of the following:

- 1) Close a door.
  - 2) Tap or push/pull around the area where the noise appears to be coming from.
  - 3) Rev the engine.
  - 4) Use a floor jack to recreate vehicle "twist".
  - 5) At idle, apply engine load (electrical load, half-clutch on M/T model, drive position on CVT and A/T models).
  - 6) Raise the vehicle on a hoist and hit a tire with a rubber hammer.
- Drive the vehicle and attempt to duplicate the conditions the customer states exist when the noise occurs.
  - If it is difficult to duplicate the noise, drive the vehicle slowly on an undulating or rough road to stress the vehicle body.

## CHECK RELATED SERVICE BULLETINS

After verifying the customer concern or symptom, check ASIST for Technical Service Bulletins (TSBs) related to that concern or symptom.

If a TSB relates to the symptom, follow the procedure to repair the noise.

## LOCATE THE NOISE AND IDENTIFY THE ROOT CAUSE

1. Narrow down the noise to a general area. To help pinpoint the source of the noise, use a listening tool (Chassis Ear: J-39570, Engine Ear: J-39565 and mechanic's stethoscope).
2. Narrow down the noise to a more specific area and identify the cause of the noise by:
  - removing the components in the area that you suspect the noise is coming from.  
Do not use too much force when removing clips and fasteners, otherwise clips and fasteners can be broken or lost during the repair, resulting in the creation of new noise.
  - tapping or pushing/pulling the component that you suspect is causing the noise.  
Do not tap or push/pull the component with excessive force, otherwise the noise will be eliminated only temporarily.
  - feeling for a vibration with your hand by touching the component(s) that you suspect is (are) causing the noise.
  - placing a piece of paper between components that you suspect are causing the noise.
  - looking for loose components and contact marks.Refer to [RF-44, "Generic Squeak and Rattle Troubleshooting"](#).

## REPAIR THE CAUSE

- If the cause is a loose component, tighten the component securely.
- If the cause is insufficient clearance between components:
  - separate components by repositioning or loosening and retightening the component, if possible.
  - insulate components with a suitable insulator such as urethane pads, foam blocks, felt cloth tape or urethane tape. A NISSAN Squeak and Rattle Kit (J-50397) is available through your authorized NISSAN Parts Department.

### **CAUTION:**

**Do not use excessive force as many components are constructed of plastic and may be damaged.**

### **NOTE:**

- Always check with the Parts Department for the latest parts information.
- The materials contained in the NISSAN Squeak and Rattle Kit (J-50397) are listed on the inside cover of the kit; and can each be ordered separately as needed.
- The following materials not found in the kit can also be used to repair squeaks and rattles.
  - SILICONE GREASE: Use instead of UHMW tape that will be visible or does not fit. The silicone grease will only last a few months.
  - SILICONE SPRAY: Use when grease cannot be applied.
  - DUCT TAPE: Use to eliminate movement.

## CONFIRM THE REPAIR

Confirm that the cause of a noise is repaired by test driving the vehicle. Operate the vehicle under the same conditions as when the noise originally occurred. Refer to the notes on the Diagnostic Worksheet.

## Generic Squeak and Rattle Troubleshooting

INFOID:000000010308756

Refer to Table of Contents for specific component removal and installation information.

## INSTRUMENT PANEL

Most incidents are caused by contact and movement between:

# SQUEAK AND RATTLE TROUBLE DIAGNOSES

## < SYMPTOM DIAGNOSIS >

1. Cluster lid A and the instrument panel
2. Acrylic lens and combination meter housing
3. Instrument panel to front pillar finisher
4. Instrument panel to windshield
5. Instrument panel pins
6. Wiring harnesses behind the combination meter
7. A/C defroster duct and duct joint

These incidents can usually be located by tapping or moving the components to duplicate the noise or by pressing on the components while driving to stop the noise. Most of these incidents can be repaired by applying felt cloth tape or silicone spray (in hard to reach areas). Urethane pads can be used to insulate wiring harness.

### **CAUTION:**

**Do not use silicone spray to isolate a squeak or rattle. If you saturate the area with silicone, you will not be able to recheck the repair.**

## CENTER CONSOLE

Components to pay attention to include:

1. Shift selector assembly cover to finisher
2. A/C control unit and cluster lid C
3. Wiring harnesses behind audio and A/C control unit

The instrument panel repair and isolation procedures also apply to the center console.

## DOORS

Pay attention to the:

1. Finisher and inner panel making a slapping noise
2. Inside handle escutcheon to door finisher
3. Wiring harnesses tapping
4. Door striker out of alignment causing a popping noise on starts and stops

Tapping or moving the components or pressing on them while driving to duplicate the conditions can isolate many of these incidents. You can usually insulate the areas with felt cloth tape or insulator foam blocks from the NISSAN Squeak and Rattle Kit (J-50397) to repair the noise.

## TRUNK

Trunk noises are often caused by a loose jack or loose items put into the trunk by the owner.

In addition look for:

1. Trunk lid bumpers out of adjustment
2. Trunk lid striker out of adjustment
3. The trunk lid torsion bars knocking together
4. A loose license plate or bracket

Most of these incidents can be repaired by adjusting, securing or insulating the item(s) or component(s) causing the noise.

## SUNROOF/HEADLINING

Noises in the sunroof/headlining area can often be traced to one of the following:

1. Sunroof lid, rail, linkage or seals making a rattle or light knocking noise
2. Sun visor shaft shaking in the holder
3. Front or rear windshield touching headlining and squeaking

Again, pressing on the components to stop the noise while duplicating the conditions can isolate most of these incidents. Repairs usually consist of insulating with felt cloth tape.

## OVERHEAD CONSOLE (FRONT AND REAR)

Overhead console noises are often caused by the console panel clips not being engaged correctly. Most of these incidents are repaired by pushing up on the console at the clip locations until the clips engage.

In addition look for:

1. Loose harness or harness connectors.
2. Front console map/reading lamp lens loose.

A  
B  
C  
D  
E  
F  
G  
H  
I  
J  
RF  
L  
M  
N  
O  
P

# SQUEAK AND RATTLE TROUBLE DIAGNOSES

## < SYMPTOM DIAGNOSIS >

---

3. Loose screws at console attachment points.

### SEATS

When isolating seat noise it's important to note the position the seat is in and the load placed on the seat when the noise is present. These conditions should be duplicated when verifying and isolating the cause of the noise.

Cause of seat noise include:

1. Headrest rods and holder
2. A squeak between the seat pad cushion and frame
3. The rear seatback lock and bracket

These noises can be isolated by moving or pressing on the suspected components while duplicating the conditions under which the noise occurs. Most of these incidents can be repaired by repositioning the component or applying urethane tape to the contact area.

### UNDERHOOD

Some interior noise may be caused by components under the hood or on the engine wall. The noise is then transmitted into the passenger compartment.

Causes of transmitted underhood noise include:

1. Any component installed to the engine wall
2. Components that pass through the engine wall
3. Engine wall mounts and connectors
4. Loose radiator installation pins
5. Hood bumpers out of adjustment
6. Hood striker out of adjustment

These noises can be difficult to isolate since they cannot be reached from the interior of the vehicle. The best method is to secure, move or insulate one component at a time and test drive the vehicle. Also, engine rpm or load can be changed to isolate the noise. Repairs can usually be made by moving, adjusting, securing, or insulating the component causing the noise.

# SQUEAK AND RATTLE TROUBLE DIAGNOSES

< SYMPTOM DIAGNOSIS >

## Diagnostic Worksheet

INFOID:0000000110308757

Dear Customer:

We are concerned about your satisfaction with your vehicle. Repairing a squeak or rattle sometimes can be very difficult. To help us fix your vehicle right the first time, please take a moment to note the area of the vehicle where the squeak or rattle occurs and under what conditions. You may be asked to take a test drive with a service advisor or technician to ensure we confirm the noise you are hearing.

### SQUEAK & RATTLE DIAGNOSTIC WORKSHEET

#### I. WHERE DOES THE NOISE COME FROM? (circle the area of the vehicle)

The illustrations are for reference only, and may not reflect the actual configuration of your vehicle.

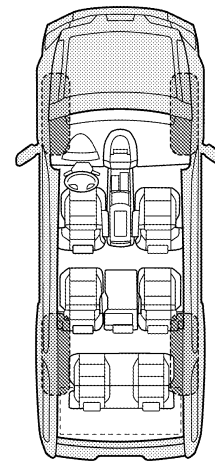
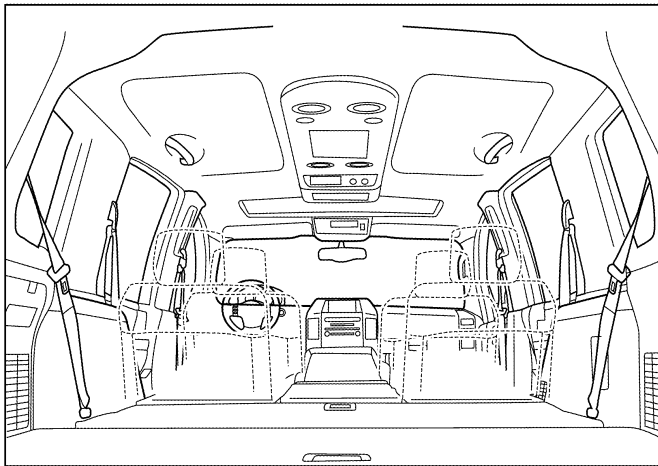
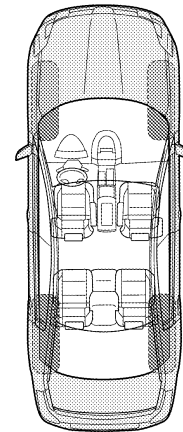
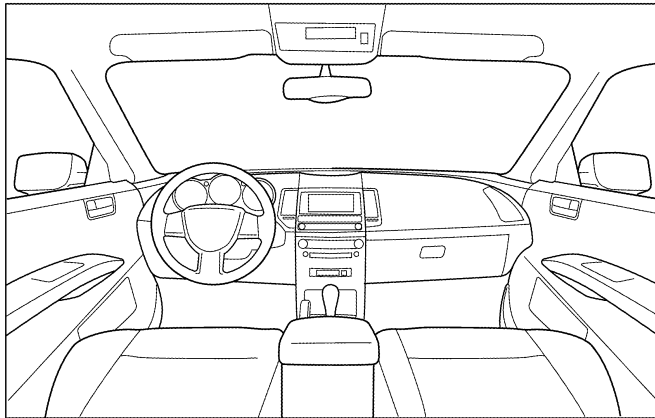

Continue to page 2 of the worksheet and briefly describe the location of the noise or rattle. In addition, please indicate the conditions which are present when the noise occurs.

A  
B  
C  
D  
E  
F  
G  
H  
I  
J  
RF  
L  
M  
N  
O  
P

# SQUEAK AND RATTLE TROUBLE DIAGNOSES

< SYMPTOM DIAGNOSIS >

## SQUEAK & RATTLE DIAGNOSTIC WORKSHEET - page 2

Briefly describe the location where the noise occurs:

\_\_\_\_\_

\_\_\_\_\_

### II. WHEN DOES IT OCCUR? (please check the boxes that apply)

- |   |  |
|---|--|
| <input type="checkbox"/> Anytime                      | <input type="checkbox"/> After sitting out in the rain |
| <input type="checkbox"/> 1st time in the morning      | <input type="checkbox"/> When it is raining or wet     |
| <input type="checkbox"/> Only when it is cold outside | <input type="checkbox"/> Dry or dusty conditions       |
| <input type="checkbox"/> Only when it is hot outside  | <input type="checkbox"/> Other:                        |

### III. WHEN DRIVING:

- Through driveways
- Over rough roads
- Over speed bumps
- Only about \_\_\_\_ mph
- On acceleration
- Coming to a stop
- On turns: left, right or either (circle)
- With passengers or cargo
- Other: \_\_\_\_\_
- After driving \_\_\_\_ miles or \_\_\_\_ minutes

### IV. WHAT TYPE OF NOISE

- Squeak (like tennis shoes on a clean floor)
- Creak (like walking on an old wooden floor)
- Rattle (like shaking a baby rattle)
- Knock (like a knock at the door)
- Tick (like a clock second hand)
- Thump (heavy muffled knock noise)
- Buzz (like a bumble bee)

### TO BE COMPLETED BY DEALERSHIP PERSONNEL

Test Drive Notes:

\_\_\_\_\_

\_\_\_\_\_

\_\_\_\_\_

	YES	NO	Initials of person performing
Vehicle test driven with customer	<input type="checkbox"/>	<input type="checkbox"/>	_____
- Noise verified on test drive	<input type="checkbox"/>	<input type="checkbox"/>	_____
- Noise source located and repaired	<input type="checkbox"/>	<input type="checkbox"/>	_____
- Follow up test drive performed to confirm repair	<input type="checkbox"/>	<input type="checkbox"/>	_____

VIN: \_\_\_\_\_ Customer Name \_\_\_\_\_

W.O.# \_\_\_\_\_ Date: \_\_\_\_\_

This form must be attached to Work Order

LAI0071E



# GLASS LID

< REMOVAL AND INSTALLATION >

## REMOVAL AND INSTALLATION

### GLASS LID

Exploded View

INFOID:000000009795003

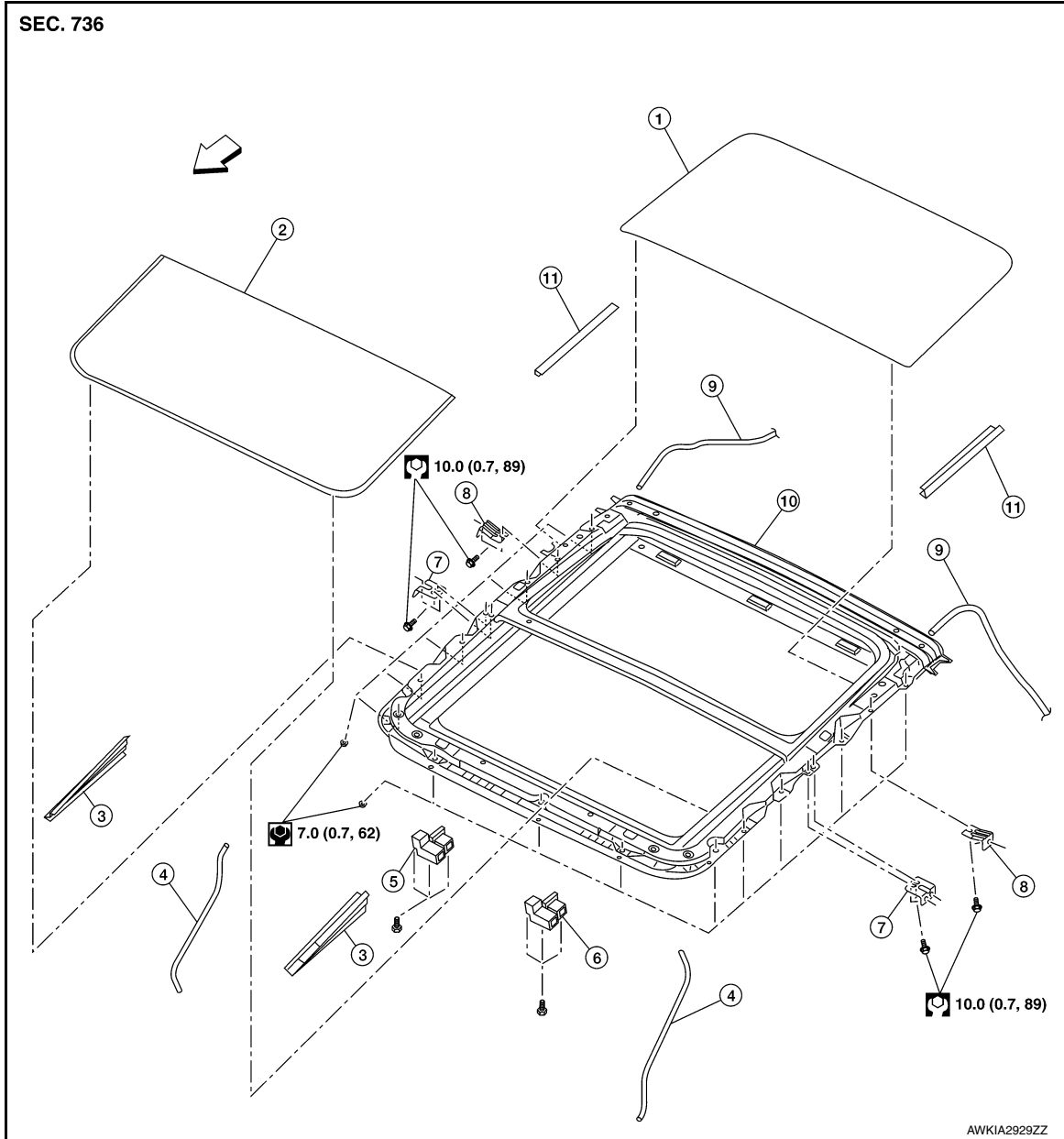

- |                                   |                                  |                             |
|-----------------------------------|----------------------------------|-----------------------------|
| 1. Panoramic roof glass           | 2. Glass lid                     | 3. Side trim covers (LH/RH) |
| 4. Front drain hose (LH/RH)       | 5. Moonroof motor assembly       | 6. Sunshade motor assembly  |
| 7. Moonroof front bracket (LH/RH) | 8. Moonroof rear bracket (LH/RH) | 9. Rear drain hose (LH/RH)  |
| 10. Moonroof unit assembly        | 11. Rear trim covers (LH/RH)     | ⇐ Front                     |

### Removal and Installation

INFOID:000000010309518

**CAUTION:**  
Handle glass lid with care to prevent damage.

#### REMOVAL

## GLASS LID

### < REMOVAL AND INSTALLATION >

1. Open sunshade (1) and close glass lid.  
⇐ Front
2. Slide the side trim covers (2) (LH/RH) inward, then release from the glass lid inside edge and set aside.
3. Remove the glass lid bolts (A) on the (LH/RH) sides.

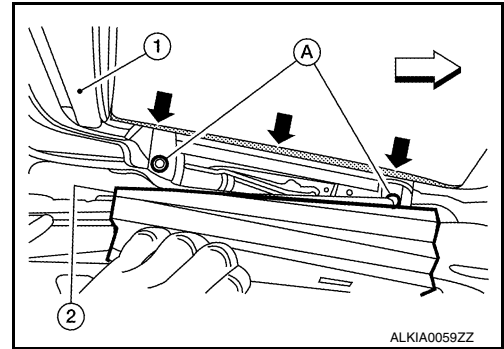

4. Remove glass lid from moonroof unit assembly.

### INSTALLATION

Installation is in the reverse order of removal.

#### **CAUTION:**

- **First tighten left front bolt, then right rear bolt to prevent uneven alignment while tightening remaining bolt.**
- **After installing glass lid, check gap/height adjustments and operation. Refer to [RF-55. "Inspection"](#).**

# PANORAMIC ROOF GLASS

< REMOVAL AND INSTALLATION >

## PANORAMIC ROOF GLASS

Exploded View

INFOID:000000010325983

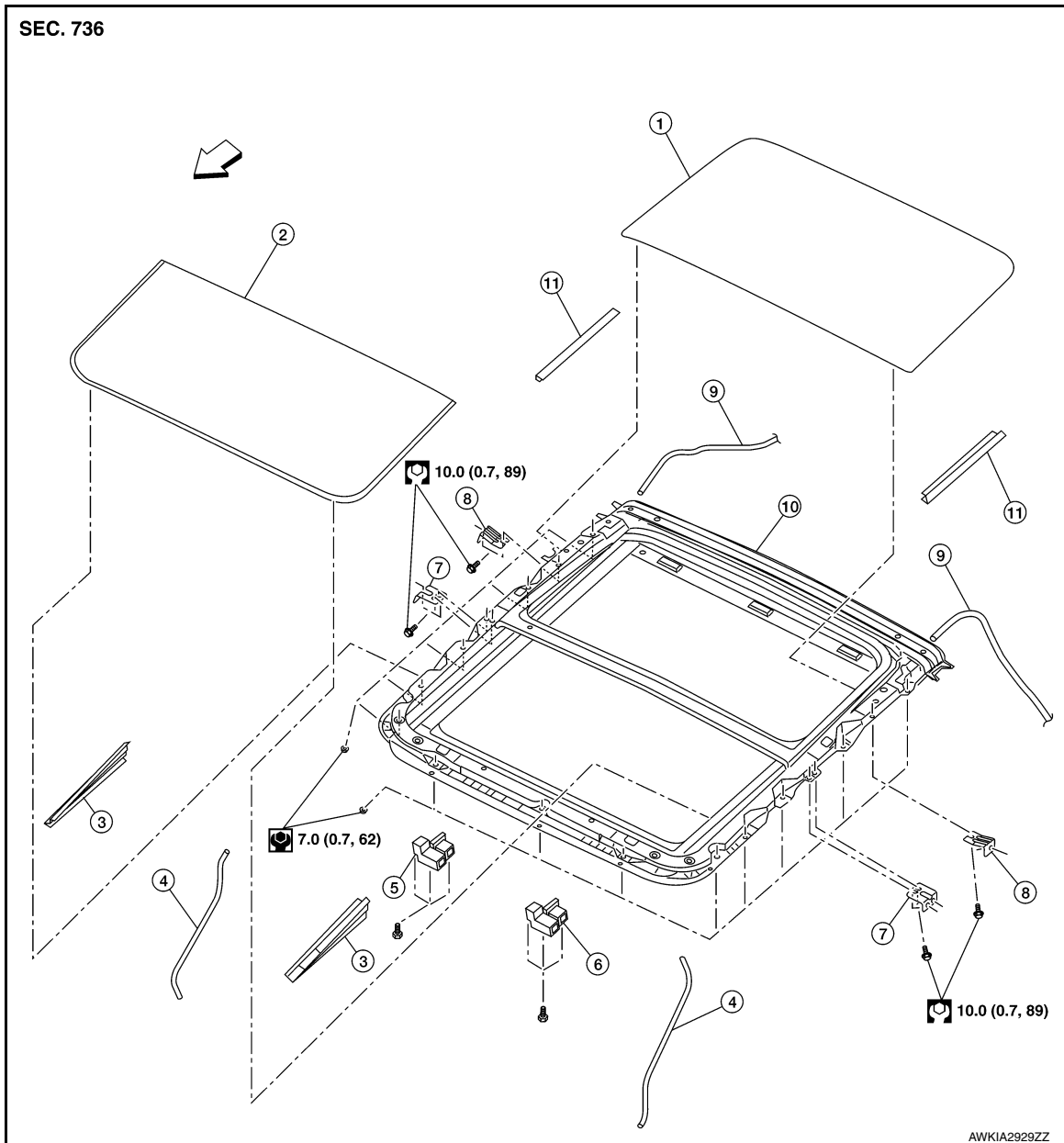

- |                                   |                                  |                             |
|-----------------------------------|----------------------------------|-----------------------------|
| 1. Panoramic roof glass           | 2. Glass lid                     | 3. Side trim covers (LH/RH) |
| 4. Front drain hose (LH/RH)       | 5. Moonroof motor assembly       | 6. Sunshade motor assembly  |
| 7. Moonroof front bracket (LH/RH) | 8. Moonroof rear bracket (LH/RH) | 9. Rear drain hose (LH/RH)  |
| 10. Moonroof unit assembly        | 11. Rear trim covers (LH/RH)     | ⇐ Front                     |

### Removal and Installation

INFOID:000000010325984

#### CAUTION:

Handle panoramic roof glass with care to prevent damage.

#### REMOVAL

1. Remove moonroof motor assembly. Refer to [RF-53, "Removal and Installation"](#).
2. Remove four screws and panoramic glass.

## PANORAMIC ROOF GLASS

< REMOVAL AND INSTALLATION >

---

### INSTALLATION

Installation is in the reverse order of removal.

**CAUTION:**

- First tighten left front screw, then right rear screw to prevent uneven alignment while tightening remaining screws.
- After installing panoramic roof glass, check gap/height adjustments and operation. Refer to [RF-55, "Inspection"](#).

# MOONROOF MOTOR ASSEMBLY

< REMOVAL AND INSTALLATION >

## MOONROOF MOTOR ASSEMBLY

Exploded View

INFOID:000000009795006

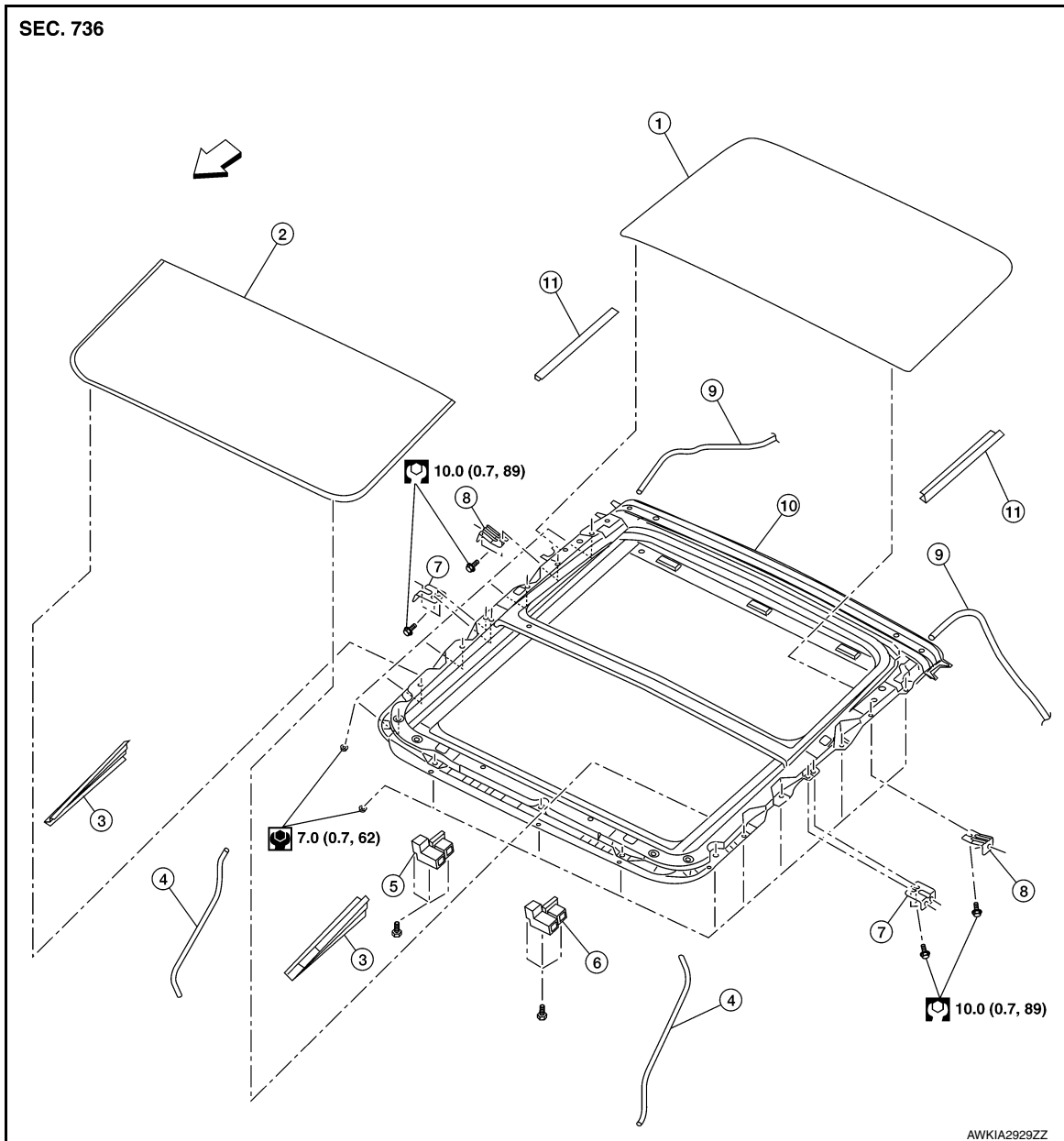

- |                                   |                                  |                             |
|-----------------------------------|----------------------------------|-----------------------------|
| 1. Panoramic roof glass           | 2. Glass lid                     | 3. Side trim covers (LH/RH) |
| 4. Front drain hose front (LH/RH) | 5. Moonroof motor assembly       | 6. Sunshade motor assembly  |
| 7. Moonroof front bracket (LH/RH) | 8. Moonroof rear bracket (LH/RH) | 9. Drain hose rear (LH/RH)  |
| 10. Moonroof unit assembly        | 11. Rear trim (LH/RH)            | ⇐ Front                     |

### Removal and Installation

INFOID:000000010309519

#### REMOVAL

1. Close glass lid.
2. Remove the headlining. Refer to [INT-30, "Removal and Installation"](#).

## MOONROOF MOTOR ASSEMBLY

### < REMOVAL AND INSTALLATION >

3. Remove moonroof motor assembly screws (1).  
↳ Front
4. Disconnect harness connector (A) and remove moonroof motor assembly (2) from moonroof unit assembly front end rail.  
**CAUTION:**  
**Do not run the removed moonroof motor assembly as a single unit.**

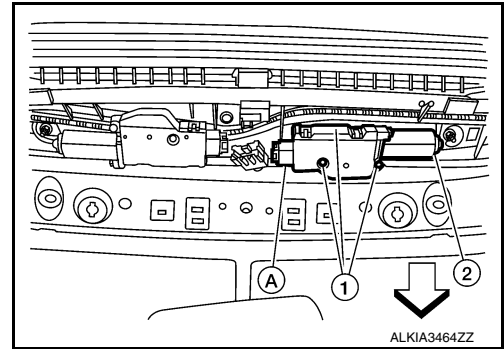

### INSTALLATION

1. Move moonroof motor assembly laterally little by little so that the gear is completely engaged into the wire on the moonroof unit assembly, and the mounting surfaces become parallel. Install the moonroof motor assembly screws and tighten.  
**CAUTION:**  
**Before installing the motor, be sure to place the link and wire assembly in the symmetrical and fully closed position.**  
**NOTE:**  
If necessary, insert a suitable tool into the drive key and rotate right or left slightly to assist in complete moonroof motor gear alignment.
2. Remainder of installation is in the reverse order of removal.
3. Synchronize moonroof motor assembly with moonroof unit assembly. Refer to [RF-24. "ADDITIONAL SERVICE WHEN REPLACING CONTROL UNIT : Special Repair Requirement"](#).

# MOONROOF UNIT ASSEMBLY

< REMOVAL AND INSTALLATION >

## MOONROOF UNIT ASSEMBLY

### Inspection

INFOID:000000010309520

#### WIND DEFLECTOR

1. Open glass lid fully.
2. Visually check for proper installation, damaged/deteriorated components, or foreign objects within mechanism. Correct as required for smooth operation.
3. Check for grease at the wind deflector arm (1) and pivot areas. If necessary, apply a sufficient amount of grease for non-binding operation.  
⇐ Front

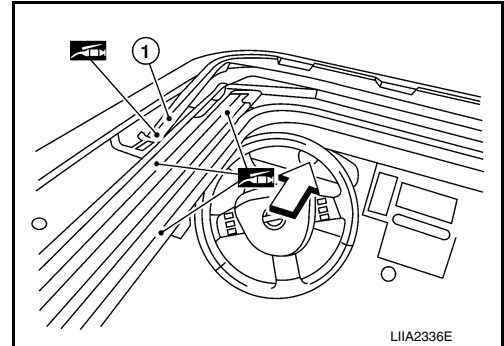

4. Check that the wind deflector (1) moves freely within the moonroof unit assembly while manually pressing down and releasing. If a malfunction is detected, remove the moonroof unit assembly and visually inspect. If damage is found, replace either wind deflector (1) or moonroof unit assembly as required. Refer to [RF-63, "Removal and Installation"](#) (WIND DEFLECTOR) or [RF-59, "Removal and Installation"](#) (MOONROOF UNIT ASSEMBLY).  
⇐ Front

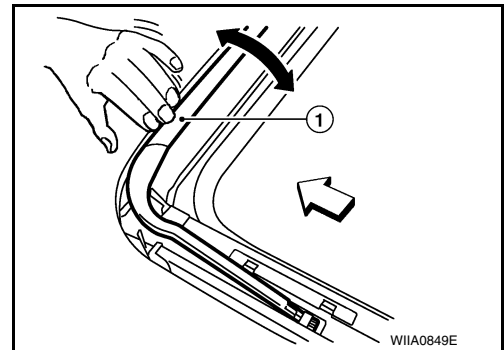

#### LINK AND WIRE ASSEMBLY

##### NOTE:

Before replacing a suspect part, make sure it is the source of noise being experienced.

1. Check link to determine if coating film has peeled off excessively enough that substrate is visible. Check also to determine if link is the source of noise. Replace as necessary.
2. Visually check to determine if a sufficient amount of grease has been applied to wire or rail groove. If not, add grease as required.
3. Check wire for any damage or deterioration. If any damage is found, replace moonroof unit assembly. Refer to [RF-59, "Removal and Installation"](#)

#### WEATHERSTRIP

1. Visually check weatherstrip for damage, deterioration, or deformation.
  - Open glass lid partially to inspect front edge of weatherstrip.
  - Tilt up glass lid fully to inspect sides and rear edge of weatherstrip.If any area of the weatherstrip is found to be damaged, replace the glass lid. Refer to [RF-49, "Removal and Installation"](#).
2. Check for leaks around glass lid.
  - Close glass lid.
  - Pour water around surface to determine area of concern.
  - For gaps or misalignment, adjust glass lid to specifications. Refer to ADJUSTMENT in this section.
  - For damaged sealing surfaces, either replace glass lid, refer to [RF-49, "Removal and Installation"](#) or repair the panel.

#### DRAIN HOSES

A  
B  
C  
D  
E  
F  
G  
H  
I  
J

RF

L  
M  
N  
O  
P

# MOONROOF UNIT ASSEMBLY

## < REMOVAL AND INSTALLATION >

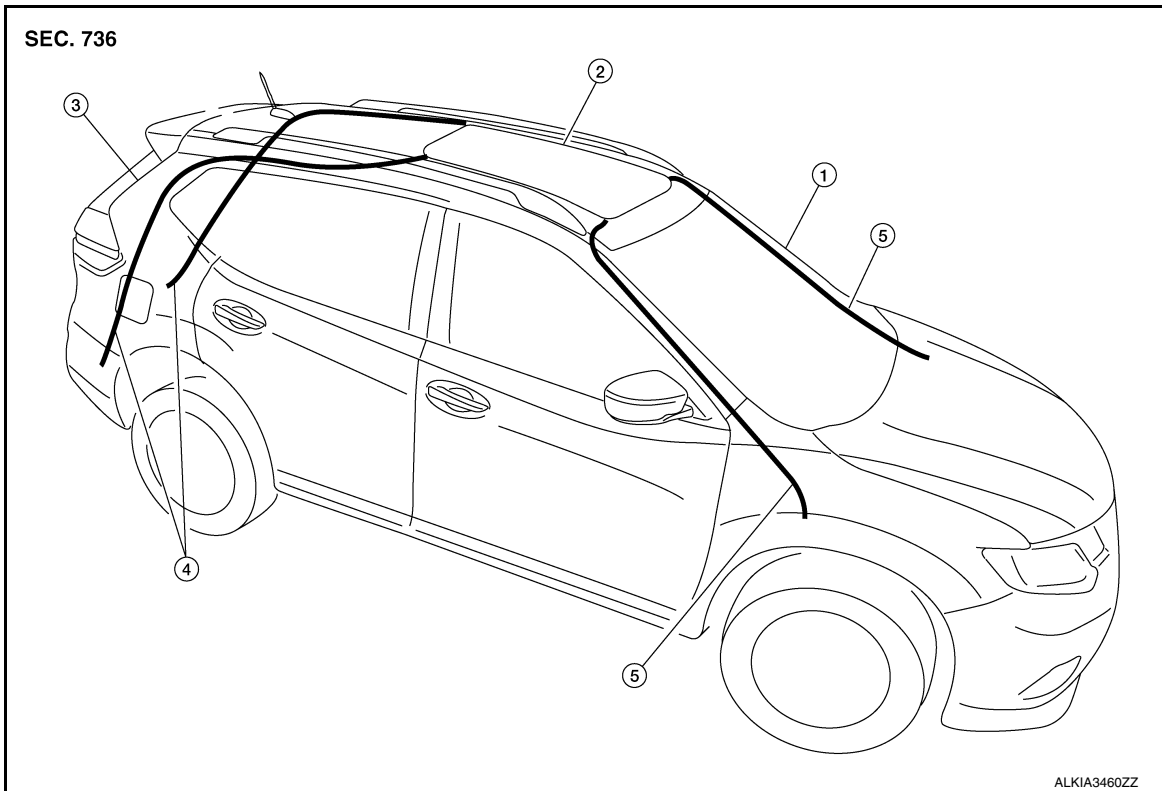

- |                             |                              |                |
|-----------------------------|------------------------------|----------------|
| 1. Front pillar             | 2. Moonroof unit assembly    | 3. Rear pillar |
| 4. Rear drain hoses (LH/RH) | 5. Front drain hoses (LH/RH) |                |

1. Remove the headlining. Refer to [INT-30, "Removal and Installation"](#).

2. From the inside front pillar (3) visually check drain hoses (1) for:
- Proper connection at moonroof unit assembly (4) and drain hose connection at the exit base (2).
  - Damage, pinch, cracks, deterioration.

⇐ Front

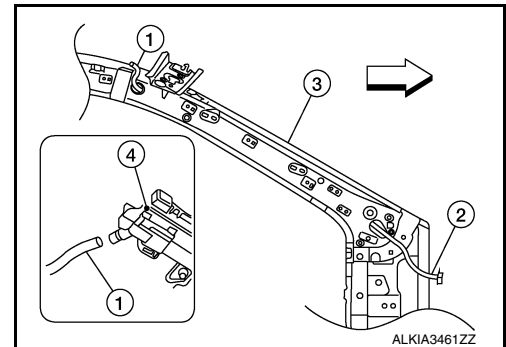

3. Pour water through drain hoses to determine watertight performance. If damaged or leaking portions in any drain hose is found, replace entire drain hose as necessary.

4. From the inside of the rear quarter panel (1) visually check drain hoses (2) for damage, pinching, cracks, or deterioration.

5. Check for proper connection at moonroof unit assembly (3) and drain hose (2) and for proper routing along the rear inner quarter panel (1).

⇐ Front

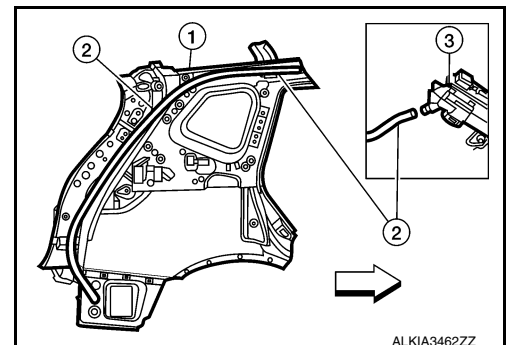

## ADJUSTMENT

### CAUTION:



# MOONROOF UNIT ASSEMBLY

## < REMOVAL AND INSTALLATION >

- Always work with a helper.
- Handle glass lid with care to prevent damage.

### NOTE:

- For easier and more accurate installation, always mark each point before removal.
- After any adjustment, check moonroof operation and glass lid alignment.

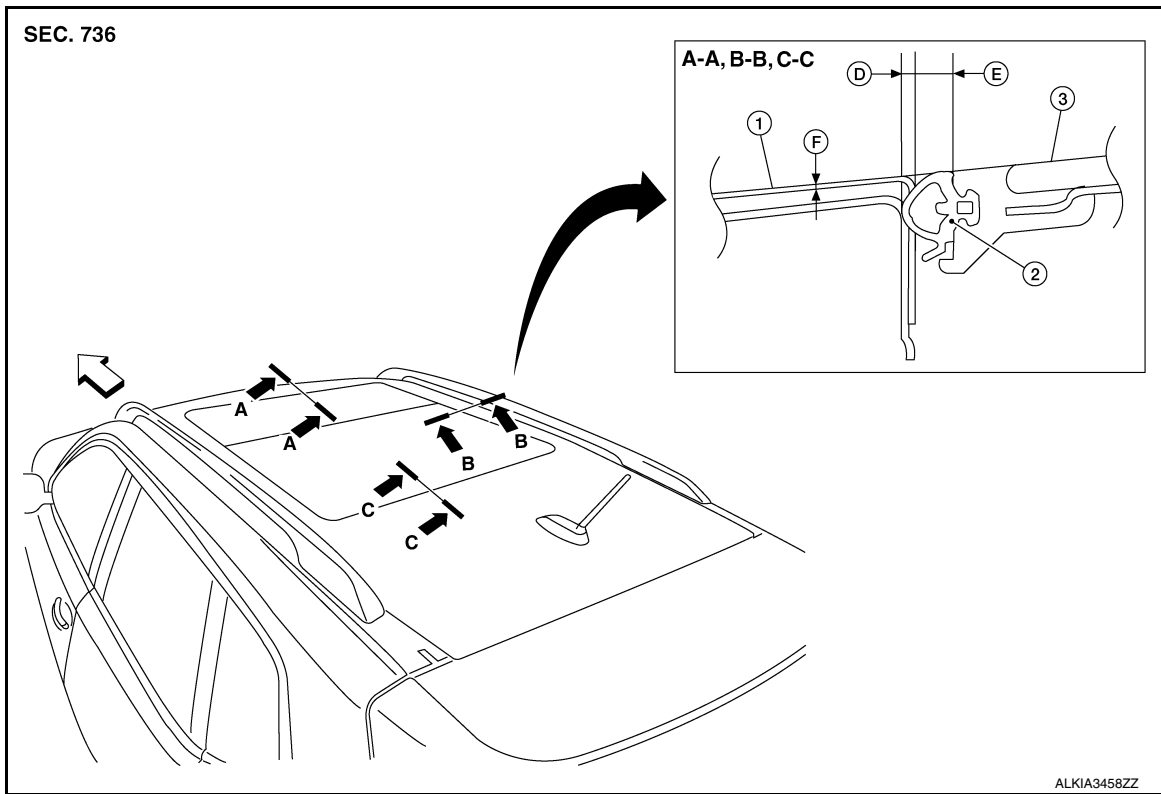

1. Roof panel

2. Weatherstrip

3. Glass lid/panoramic roof glass

↔ Front

Unit: mm (in)

Portion	Gap		Surface height difference
	D	E	F
A-A	$1.4 \pm 0.8$ (0.06 ± 0.03)	$7.3 \pm 0.8$ (0.29 ± 0.03)	$0.7 \pm 1.5$ (0.03 ± 0.06)
B-B	$1.4 \pm 0.8$ (0.06 ± 0.03)	$7.3 \pm 0.8$ (0.29 ± 0.03)	$0.7 \pm 1.5$ (0.03 ± 0.06)
C-C	$1.4 \pm 0.8$ (0.06 ± 0.03)	$7.3 \pm 0.8$ (0.29 ± 0.03)	$0.7 \pm 1.5$ (0.03 ± 0.06)

### Gap adjustment (Front and Rear)

1. Open sunshade (1).  
↔ Front
2. Tilt glass lid up, then release side trim cover (2) on each side and set aside.  
**NOTE:**  
LH side shown; RH similar.
3. Loosen glass lid bolts (A) (two each on LH and RH side), then tilt glass lid down.
4. Manually adjust glass lid from outside of vehicle until gaps A-A and C-C are within specification.  
**NOTE:**

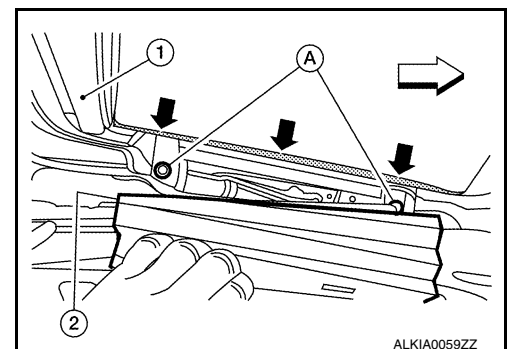

ALKIA0059ZZ

Temporarily loosely tighten glass lid bolts to prevent movement between each adjustment.

5. Tilt glass lid up and down several times using moonroof switch to check that it operates smoothly.

# MOONROOF UNIT ASSEMBLY

## < REMOVAL AND INSTALLATION >

---

6. Tilt glass lid up and tighten bolts.

**NOTE:**

First tighten left front bolt, then right rear bolt on glass lid to prevent uneven torque while tightening remaining bolts.

7. Attach side trim covers (LH/RH), then tilt glass lid down.

### Gap Adjustment (Sides)

The moonroof unit assembly is mounted on locator pins and adjustment from side to side cannot be performed.

### Surface Height Adjustment

1. Tilt glass lid up and down several times using moonroof switch to check that it operates smoothly.
2. Check height difference between roof surface and glass lid surface, then compare to specifications.
3. If necessary, adjust height difference by using the following procedure.

- Loosen glass lid bolts.
- Manually raise/lower glass lid until height difference is within specification.

**NOTE:**

If necessary, shims may be added between moonroof unit assembly and roof to increase adjustment range. Refer to [RF-49, "Removal and Installation"](#).

Temporarily loosely tighten moonroof unit assembly bolts to prevent movement between each adjustment.

- Tilt glass lid up and down several times using moonroof switch to check that it operates smoothly.
- Tighten glass lid and moonroof side bracket bolts.

**NOTE:**

First tighten left front bolt, then right rear bolt on glass lid to prevent uneven torque while tightening remaining bolts.

- After any adjustment, check moonroof operation and glass lid alignment.

# MOONROOF UNIT ASSEMBLY

< REMOVAL AND INSTALLATION >

Exploded View

INFOID:000000010309521

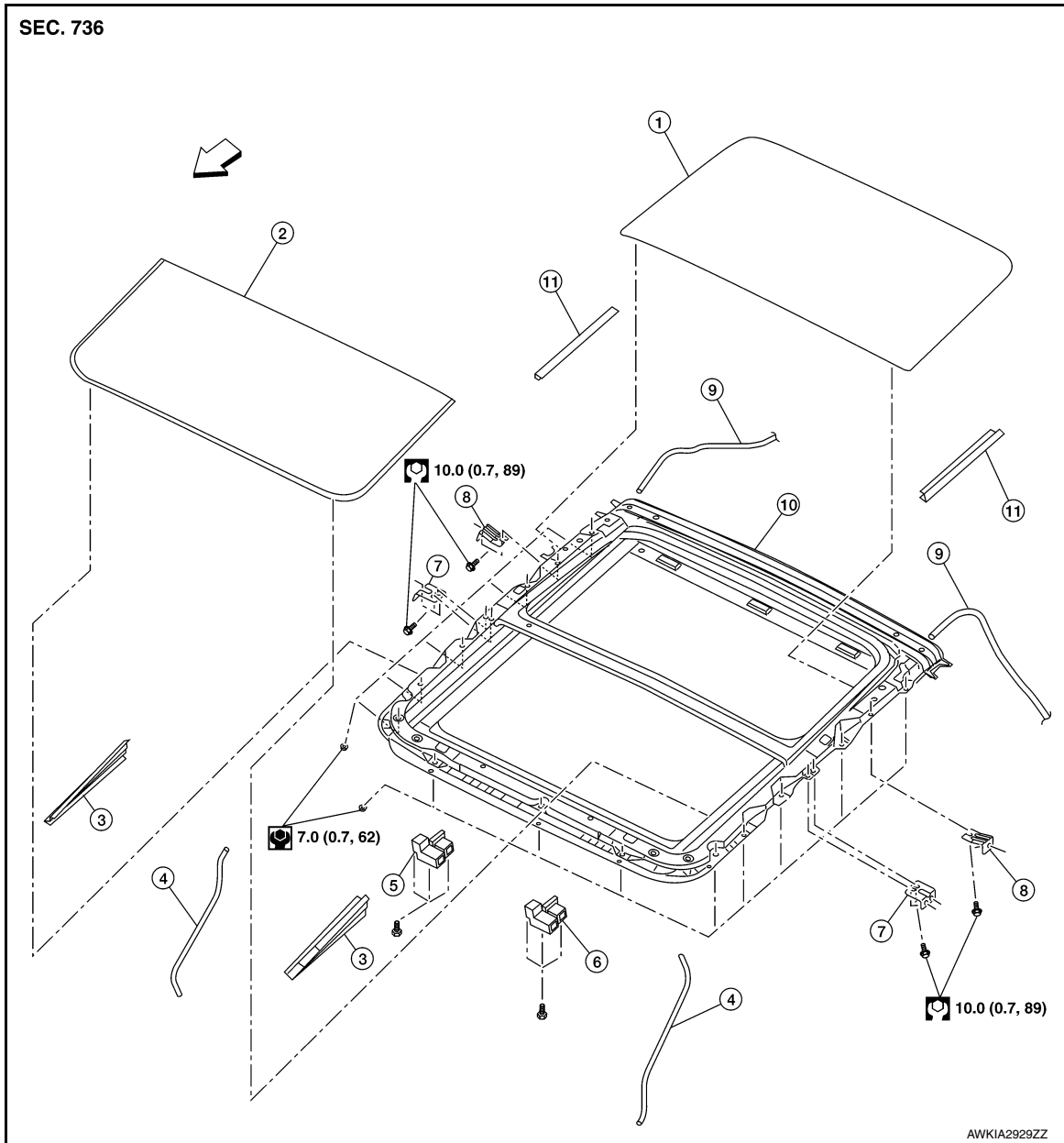

- |                                   |                                  |                             |
|-----------------------------------|----------------------------------|-----------------------------|
| 1. Panoramic roof glass           | 2. Glass lid                     | 3. Side trim covers (LH/RH) |
| 4. Front drain hose (LH/RH)       | 5. Moonroof motor assembly       | 6. Sunshade motor assembly  |
| 7. Moonroof front bracket (LH/RH) | 8. Moonroof rear bracket (LH/RH) | 9. Rear drain hose (LH/RH)  |
| 10. Moonroof unit assembly        | 11. Rear trim covers (LH/RH)     | ⇐ Front                     |

## Removal and Installation

INFOID:000000010309517

### REMOVAL

#### CAUTION:

- Always work with a helper.
- When taking moonroof unit assembly out, use cloths to protect the seats and trim from damage.

1. Remove headlining. Refer to [INT-30, "Removal and Installation"](#).
2. Disconnect drain hoses (front/rear) from moonroof unit assembly. Refer to [RF-55, "Inspection"](#).
3. Disconnect harness connectors from moonroof motor assembly and sunshade motor assembly.

## MOONROOF UNIT ASSEMBLY

### < REMOVAL AND INSTALLATION >

---

4. Remove nuts, then using a helper carefully lift each side and remove moonroof unit assembly out back of vehicle.

**WARNING:**

**Bodily injury may occur if moonroof unit assembly is not supported properly when removing.**

### INSTALLATION

Installation is in the reverse order of removal.

**CAUTION:**

**After installing the moonroof unit assembly, perform the leak test and check that there is no air or water intrusion. Refer to [RF-55, "Inspection"](#).**

# SUNSHADE

< REMOVAL AND INSTALLATION >

## SUNSHADE

### Removal and Installation

INFOID:000000010309536

#### REMOVAL

1. Remove the moonroof unit assembly. Refer to [RF-53, "Removal and Installation"](#).
2. Place the moonroof unit assembly (1) on a flat surface upside down and remove sunshade (2) screws (A).

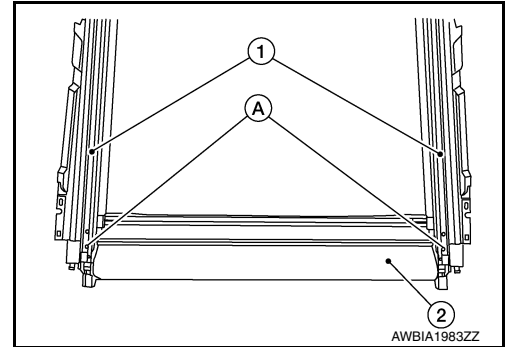

3. Manually move sunshade motor (1) using suitable tool (2).

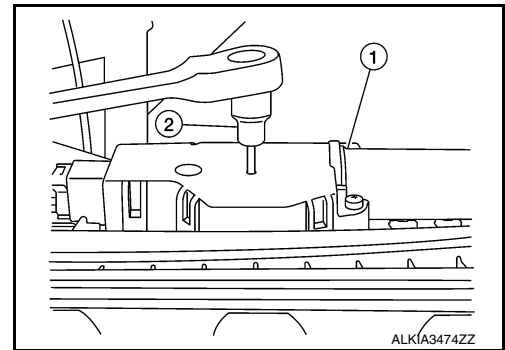

4. After manually moving sunshade with suitable tool, gently pull reward on sunshade to reveal cable.
5. While holding black plastic part on the cable end push sunshade toward opposite end releasing from the cable.
6. Remove sunshade.

#### INSTALLATION

Installation is in the reverse order of removal.

A  
B  
C  
D  
E  
F  
G  
H  
I  
J  
RF  
L  
M  
N  
O  
P

# SUNSHADE MOTOR ASSEMBLY

< REMOVAL AND INSTALLATION >

## SUNSHADE MOTOR ASSEMBLY

### Removal and Installation

INFOID:000000010309523

#### REMOVAL

1. Remove the headlining. Refer to [INT-30, "Removal and Installation"](#).
2. Disconnect the harness connector (A) from the sunshade motor assembly (1).
3. Remove sunshade motor assembly screws (B).
4. Remove the sunshade motor assembly from the moonroof unit assembly (2).

↩ Front

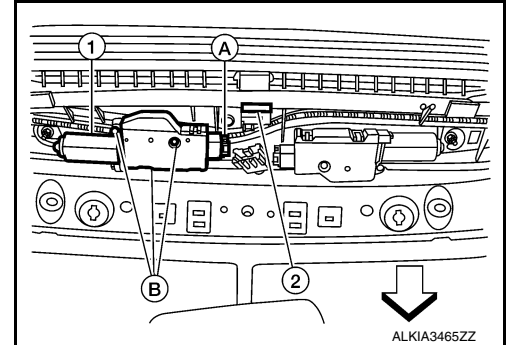

#### INSTALLATION

Installation is in the reverse order of removal.

- Synchronize sunshade motor assembly with moonroof unit assembly. Refer to [RF-24, "ADDITIONAL SERVICE WHEN REPLACING CONTROL UNIT : Special Repair Requirement"](#).

# WIND DEFLECTOR

< REMOVAL AND INSTALLATION >

## WIND DEFLECTOR

### Removal and Installation

INFOID:000000010309524

#### REMOVAL

1. Remove headlining Refer to [INT-30. "Removal and Installation"](#).
2. Open the glass lid to view the wind deflector.
3. Use suitable tool (A) release pawl on LH/RH side of wind deflector.

⊖: Pawl

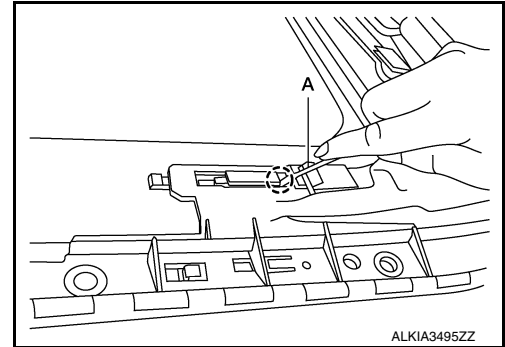

4. Release wind deflector retainer (1) from moonroof unit (2).

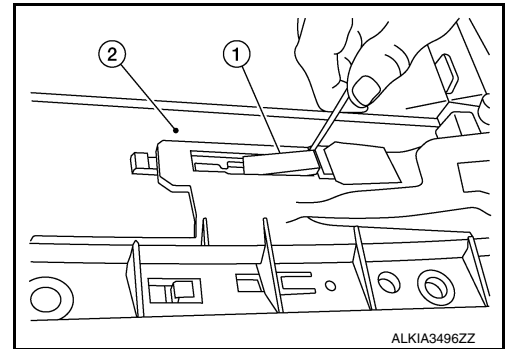

5. Remove screws (A) on both LH/RH sides of wind deflector.

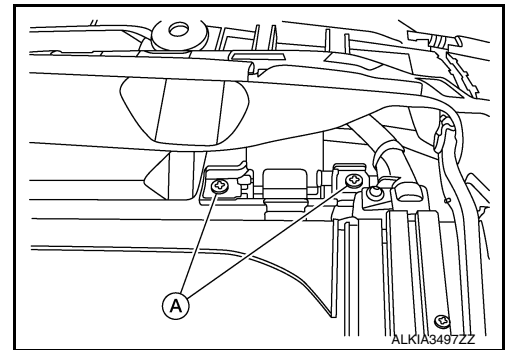

#### INSTALLATION

Installation is in the reverse order of removal.

A  
B  
C  
D  
E  
F  
G  
H  
I  
J  
RF  
L  
M  
N  
O  
P

# MOONROOF SWITCH

< REMOVAL AND INSTALLATION >

## MOONROOF SWITCH

### Removal and Installation

INFOID:000000010309525

#### REMOVAL

1. Remove map lamp assembly. Refer to [INL-55, "Removal and Installation"](#).

2. Using a suitable tool release clip from harness connector.

△: Clip

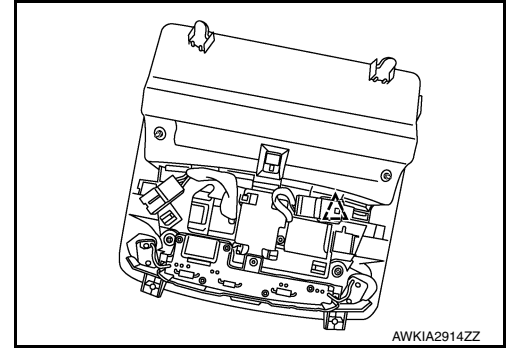

3. Using a suitable tool release pawls and remove moonroof switch finisher (1).

4. Using a suitable tool release pawls and remove moonroof switch (2) from the front room/map lamp.

○: Pawl

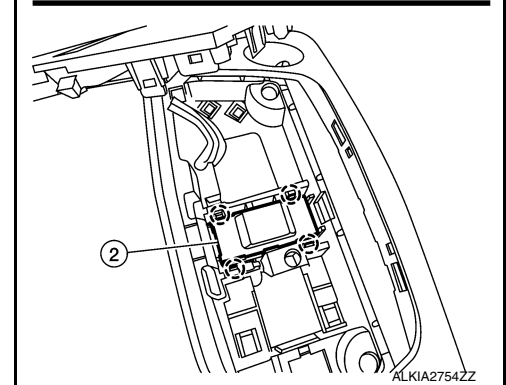
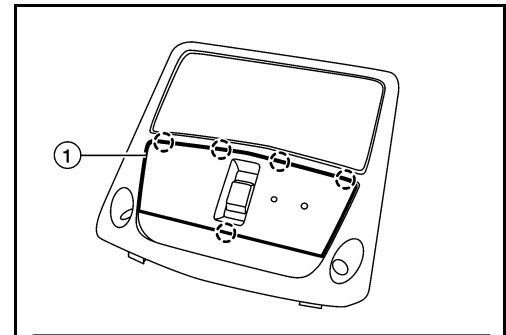

#### INSTALLATION

Installation is in the reverse order of removal.