

SECTION **RSU**

REAR SUSPENSION

A
B
C
D

RSU

CONTENTS

PRECAUTION	2	Inspection	14	F
PRECAUTIONS	2	Disposal	15	
Precaution for Supplemental Restraint System (SRS) "AIR BAG" and "SEAT BELT PRE-TENSIONER"	2	REAR SUSPENSION ARM	16	G
Precautions for Suspension	2	Exploded View	16	
PREPARATION	3	Removal and Installation	16	H
PREPARATION	3	Inspection	16	
Special Service Tool	3	LOWER LINK	17	I
Commercial Service Tool	3	Exploded View	17	
SYMPTOM DIAGNOSIS	4	Removal and Installation	17	J
NOISE, VIBRATION AND HARSHNESS (NVH) TROUBLESHOOTING	4	Inspection	17	
NVH Troubleshooting Chart	4	UPPER LINK	19	K
PERIODIC MAINTENANCE	5	Exploded View	19	
REAR SUSPENSION ASSEMBLY	5	Removal and Installation	19	L
Inspection and Adjustment	5	Inspection	20	
WHEEL ALIGNMENT	6	REAR STABILIZER	21	M
Inspection	6	Exploded View	21	
Adjustment	6	Removal and Installation	21	N
REMOVAL AND INSTALLATION	8	Inspection	21	
COIL SPRING	8	UNIT REMOVAL AND INSTALLATION	22	O
Exploded View	8	REAR SUSPENSION MEMBER	22	
Removal and Installation - FWD	8	Exploded View	22	P
Removal and Installation - AWD	10	Removal and Installation - FWD	22	
Inspection	13	Removal and Installation - AWD	23	
REAR SHOCK ABSORBER	14	Inspection	23	
Exploded View	14	SERVICE DATA AND SPECIFICATIONS (SDS)	24	
Removal and Installation	14	SERVICE DATA AND SPECIFICATIONS (SDS)	24	
		Wheel Alignment (Unladen*1)	24	
		Wheelarch Height (Unladen*)	24	

PRECAUTIONS

< PRECAUTION >

PRECAUTION

PRECAUTIONS

Precaution for Supplemental Restraint System (SRS) "AIR BAG" and "SEAT BELT PRE-TENSIONER"

INFOID:000000010269528

The Supplemental Restraint System such as "AIR BAG" and "SEAT BELT PRE-TENSIONER", used along with a front seat belt, helps to reduce the risk or severity of injury to the driver and front passenger for certain types of collision. Information necessary to service the system safely is included in the SR and SB section of this Service Manual.

WARNING:

- To avoid rendering the SRS inoperative, which could increase the risk of personal injury or death in the event of a collision which would result in air bag inflation, all maintenance must be performed by an authorized NISSAN/INFINITI dealer.
- Improper maintenance, including incorrect removal and installation of the SRS, can lead to personal injury caused by unintentional activation of the system. For removal of Spiral Cable and Air Bag Module, see the SR section.
- Do not use electrical test equipment on any circuit related to the SRS unless instructed to in this Service Manual. SRS wiring harnesses can be identified by yellow and/or orange harnesses or harness connectors.

PRECAUTIONS WHEN USING POWER TOOLS (AIR OR ELECTRIC) AND HAMMERS

WARNING:

- When working near the Airbag Diagnosis Sensor Unit or other Airbag System sensors with the Ignition ON or engine running, DO NOT use air or electric power tools or strike near the sensor(s) with a hammer. Heavy vibration could activate the sensor(s) and deploy the air bag(s), possibly causing serious injury.
- When using air or electric power tools or hammers, always switch the Ignition OFF, disconnect the battery and wait at least three minutes before performing any service.

Precautions for Suspension

INFOID:000000009797547

- When installing rubber bushings, the final tightening must be carried out under unladen conditions with tires on ground. Spilled oil might shorten the life of rubber bushings. Be sure to wipe off any spilled oil.
- Unladen conditions mean that fuel, engine coolant and lubricants are full. Spare tire, jack, hand tools and mats are in designated positions.
- After servicing suspension parts, be sure to check wheel alignment.
- Self-lock nuts are not reusable. Always use new ones when installing. Since new self-lock nuts are pre-oiled, tighten as they are.

PREPARATION

< PREPARATION >

PREPARATION

PREPARATION

Special Service Tool

INFOID:000000010350107

The actual shape of the tools may differ from those illustrated here.

Tool number (TechMate No.) Tool name	Description
— (J-49286) Drift and Pull gauge	Measuring drift and pull

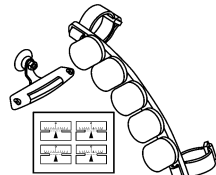

AWEIA0156ZZ

Commercial Service Tool

INFOID:000000009797548

Tool name	Description
Power tool	Loosening nuts, screws and bolts



PIIB1407E

A
B
C
D
E
F
G
H
I
J
K
L
M
N
O
P

RSU

NOISE, VIBRATION AND HARSHNESS (NVH) TROUBLESHOOTING

< SYMPTOM DIAGNOSIS >

SYMPTOM DIAGNOSIS

NOISE, VIBRATION AND HARSHNESS (NVH) TROUBLESHOOTING

NVH Troubleshooting Chart

INFOID:000000009797546

Use chart below to find the cause of the symptom. If necessary, repair or replace these parts.

Symptom		Possible cause and SUSPECTED PARTS													Reference			
		Improper installation, looseness	Shock absorber deformation, damage or deflection	Bushing or mount deterioration	Parts interference	Spring fatigue	Suspension looseness	Incorrect wheel alignment	Stabilizer bar fatigue	PROPELLER SHAFT (AWD)	DIFFERENTIAL (AWD)	REAR AXLE	TIRE	WHEEL		DRIVE SHAFT (AWD)	BRAKE	
Noise	REAR SUSPENSION	x	x	x	x	x	x			x	x	x	x	x	x	x	RSU-8, RSU-14, RSU-16, RSU-17, RSU-19, RSU-21	
		x	x	x	x		x			x		x	x	x	x	x	RSU-14	
		x	x	x	x	x												—
		x	x	x	x													—
		x	x	x														—
		x	x	x														RSU-8, RSU-14, RSU-16, RSU-17, RSU-19, RSU-21
Shake	REAR SUSPENSION																RSU-6	
																	RSU-21	
																	DLN-9Z	
																	DLN-110	
																		RAX-5 (FWD) and RAX-13 (AWD)
																		WT-55
Vibration	REAR SUSPENSION																WT-55	
																	WT-55	
																	RAX-13 (AWD)	
																	BR-6	
Shimmy	REAR SUSPENSION																	
Shudder	REAR SUSPENSION																	
Poor quality ride or handling	REAR SUSPENSION																	

x: Applicable

REAR SUSPENSION ASSEMBLY

< PERIODIC MAINTENANCE >

PERIODIC MAINTENANCE

REAR SUSPENSION ASSEMBLY

Inspection and Adjustment

INFOID:000000009797549

COMPONENT PART

Check the conditions (looseness, backlash) of each component and component conditions (wear, damage) are normal.

SHOCK ABSORBER

Check the shock absorber for oil leaks or damage. Replace the components if necessary.

A

B

C

D

RSU

F

G

H

I

J

K

L

M

N

O

P

WHEEL ALIGNMENT

< PERIODIC MAINTENANCE >

WHEEL ALIGNMENT

Inspection

INFOID:000000009797550

DESCRIPTION

- Measure wheel alignment under unladen conditions.

NOTE:

“Unladen conditions” means that fuel, engine coolant, and lubricants are full. Spare tire, jack, hand tools and mats are in designated positions.

PRELIMINARY CHECK

Check the following:

- Tires for improper air pressure and wear. Refer to [WT-65, "Tire Air Pressure"](#).
- Wheels for runout, deformation, cracks, or other damage. Refer to [WT-56, "Inspection"](#).
- Wheel bearings for axial end play. Refer to [RAX-8, "Inspection"](#) (FWD), [RAX-18, "Inspection"](#) (AWD).
- Shock absorbers for proper operation.
- Each suspension component for cracks, looseness, deformation, and other damages.
- Wheelarch height. Refer to [RSU-24, "Wheelarch Height \(Unladen*\)"](#).

GENERAL INFORMATION AND RECOMMENDATIONS

- A four-wheel thrust alignment should be performed.
- This type of alignment is recommended for any NISSAN/INFINITI vehicle.
- The four-wheel “thrust” process helps ensure that the vehicle is properly aligned and the steering wheel is centered.
- The alignment rack itself should be capable of accepting any NISSAN/INFINITI vehicle.
- The rack should be checked to ensure that it is level.
- Make sure the machine is properly calibrated.
- Your alignment equipment should be regularly calibrated in order to give correct information.
- Check with the manufacturer of your specific equipment for their recommended Service/Calibration Schedule.

ALIGNMENT PROCESS

IMPORTANT:

Use only the alignment specifications listed in this Service Manual [RSU-24, "Wheel Alignment \(Unladen*1\)"](#).

- When displaying the alignment settings, many alignment machines use “indicators”: (Green/red, plus or minus, Go/No Go). **Do not use these indicators.**
- The alignment specifications programmed into your machine that operate these indicators may not be correct.
- This may result in an ERROR.
- Most camera-type alignment machines are equipped with both “Rolling Compensation” method and optional “Jacking Compensation” method to “compensate” the alignment targets or head units. “Rolling Compensation” is the preferred method.
- If using the “Rolling Compensation” method, after installing the alignment targets or head units, push or pull on the rear wheel to move the vehicle. **Do not push or pull on the vehicle body.**
- If using the “Jacking Compensation” method, after installing the alignment targets or head units, raise the vehicle and rotate the wheels 1/2 turn both ways.

NOTE:

- Do not use the “Rolling Compensation” method if you are using sensor-type alignment equipment.
- Follow all instructions for the alignment machine you’re using for more information.

Adjustment

INFOID:000000009797551

CAMBER

WHEEL ALIGNMENT

< PERIODIC MAINTENANCE >

If camber is outside the standard value, adjust with adjusting bolt (1) in lower link (2).

Camber: Refer to [RSU-6, "Adjustment"](#).

CAUTION:

After adjusting camber, be sure to check toe-in.

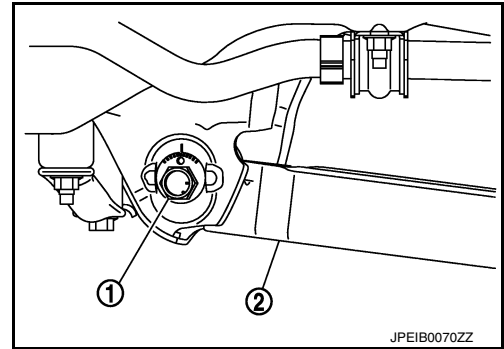

TOE-IN

If toe-in is not within the specification, adjust with adjusting bolt (1) in suspension arm (2).

Toe-In: Refer to [RSU-6, "Adjustment"](#).

CAUTION:

- Be sure to adjust equally on RH and LH side with adjusting bolt.
- When tightening the nut firmly and checking the torque, use a wrench to prevent the turning of the bolt.
- If toe-in is not still within the specification, inspect and replace any damaged or worn suspension parts.
- After toe-in adjustment, adjust neutral position of steering angle sensor. Refer to [BRC-70, "Work Procedure"](#).

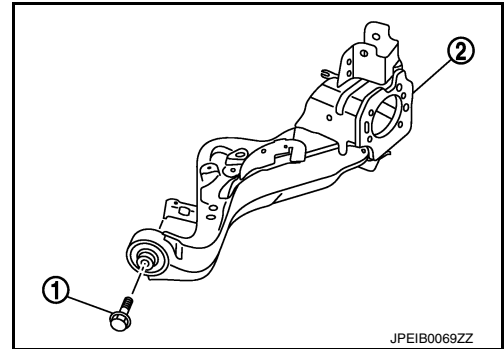

A
B
C
D
RSU
F
G
H
I
J
K
L
M
N
O
P

COIL SPRING

< REMOVAL AND INSTALLATION >

REMOVAL AND INSTALLATION

COIL SPRING

Exploded View

INFOID:000000009797552

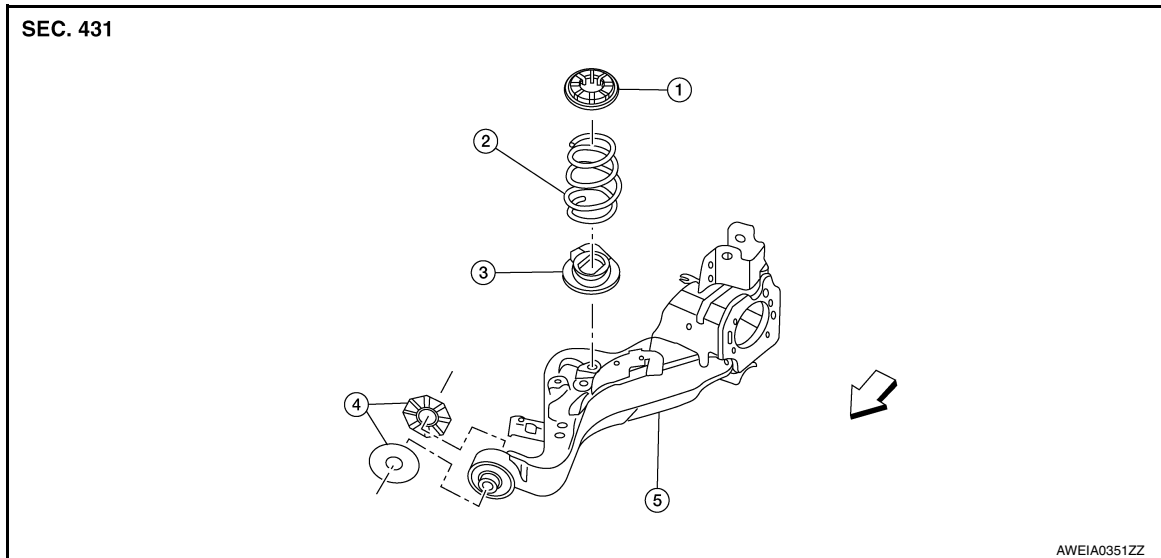

- | | | |
|--------------------------|------------------------|---------------|
| 1. Upper seat | 2. Coil spring | 3. Lower seat |
| 4. Rubber washer (LH/RH) | 5. Rear suspension arm | ⇐ Front |

Removal and Installation - FWD

INFOID:000000010346384

REMOVAL

1. Remove the rear wheel and tire using power tool.
2. Remove the bolt and separate the rear wheel sensor from the wheel hub and bearing. Refer to [BRC-133, "REAR WHEEL SENSOR : Exploded View"](#).
CAUTION:
 - Failure to separate the rear wheel sensor from the wheel hub and bearing may result in damage to the rear wheel sensor.
 - Pull out the rear wheel sensor, being careful to turn it as little as possible. Do not pull on wheel sensor harness.
3. Remove torque member bolts, leaving the brake hose attached. Position brake caliper aside with wire. Refer to [BR-42, "BRAKE CALIPER ASSEMBLY : Exploded View"](#).
CAUTION:
Do not depress brake pedal while brake caliper is removed.
4. Put alignment marks on the disc brake rotor and on wheel hub and bearing. Remove the disc brake rotor.
CAUTION:
Do not drop the disc brake rotor.
5. Support the rear suspension arm using a suitable jack.
CAUTION:
Do not damage the rear suspension arm with the suitable jack.
6. Remove the stabilizer connecting rod. Refer to [RSU-17, "Exploded View"](#).
7. Separate the parking brake cable from the rear suspension arm. Refer to [PB-7, "Exploded View"](#).
8. Remove the rear height sensor (if equipped). Refer to [EXL-271, "Removal and Installation - Rear Height Sensor"](#).
9. Remove the rear shock absorber lower bolt and nut. Separate the rear shock absorber from the rear suspension arm. Refer to [RSU-8, "Exploded View"](#).

COIL SPRING

< REMOVAL AND INSTALLATION >

10. Remove the upper link bolt and nut from the rear suspension arm. Separate the upper link from the rear suspension arm. Refer to [RSU-16. "Exploded View"](#).
11. Loosen the lower link nut at the rear suspension member. Remove the lower link bolt and nut from the rear suspension arm. Separate the lower link from the rear suspension arm. Refer to [RSU-16. "Exploded View"](#).
12. Separate the brake tube from the rear suspension arm. Refer to [BR-24. "REAR : Exploded View"](#).
13. Slowly lower the suitable jack supporting the rear suspension arm. Remove the upper seat, the coil spring and the lower seat.

INSTALLATION

1. Align the lower seat indentations (C) with rear suspension arm grooves (B). Install the lower seat protrusion (A) into the hole in the rear suspension arm.

CAUTION:

The lower rubber seat protrusion must be securely inserted into the hole of rear suspension arm.

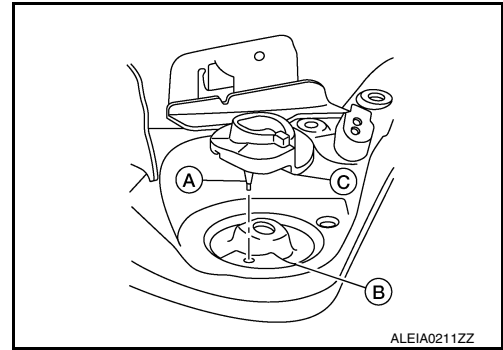

2. Identify the upper side of the coil spring.

NOTE:

- The top of the coil spring has a flat shape.
- The paint identification mark (A) is 1.75 turns from the bottom of the coil spring.

⇐ : Upper side

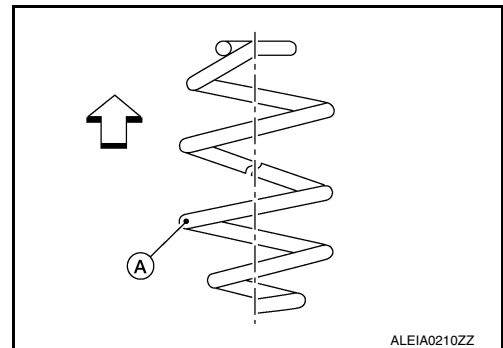

3. Align the coil spring (1) to the lower seat (2). Install coil spring to lower seat.

Maximum distance (A) : 5mm (0.20 in)

CAUTION:

Assemble coil spring so that spring lower end is located in the spring end holding section of lower rubber seat.

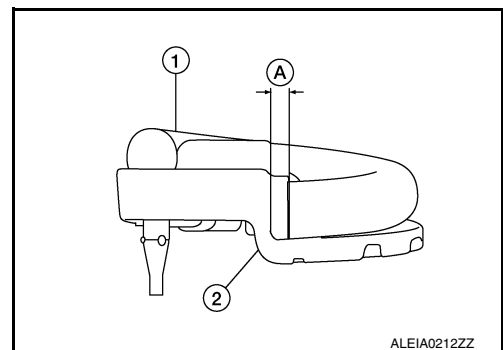

COIL SPRING

< REMOVAL AND INSTALLATION >

- Align upper seat (2) to the body (1). Slowly raise the suitable jack supporting the rear suspension arm to install the upper seat to the body.

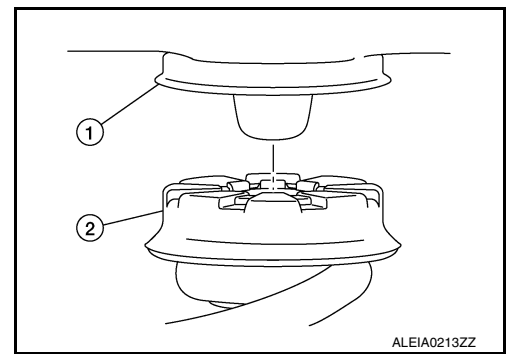

- Install brake tube to rear suspension arm. Refer to [BR-24, "REAR : Exploded View"](#).
- Install lower link with bolt and nut to the rear suspension arm. Refer to [RSU-16, "Exploded View"](#).
NOTE:
The final tightening of nuts and bolts is under unladen conditions with tires on level ground.
- Install upper link with bolt and nut to rear suspension arm. Refer to [RSU-16, "Exploded View"](#).
- Install rear shock absorber with bolt and nut to rear suspension arm. Refer to [RSU-8, "Exploded View"](#).
- Install height sensor (if equipped) to rear suspension arm. Refer to [EXL-271, "Removal and Installation - Rear Height Sensor"](#).
- Install parking brake cable to rear suspension arm. Refer to [PB-7, "Exploded View"](#).
- Install the stabilizer connecting rod. Refer to [EXL-271, "Removal and Installation - Rear Height Sensor"](#).
- Install the rear wheel sensor to the axle housing. Refer to [BRC-133, "REAR WHEEL SENSOR : Exploded View"](#).
CAUTION:
 - Before installing, make sure there is no foreign material such as iron fragments adhered to the pick-up part of the rear wheel sensor.
 - When installing, make sure there is no foreign material such as iron fragments on and in the hole in the wheel hub and bearing for the rear wheel sensor. Make sure no foreign material has been caught in the sensor rotor. Remove and foreign material and clean the mount.
- Align the matching marks on the disc brake rotor and on the wheel hub and bearing. Install the disc brake rotor.
- Install the brake caliper and the torque member bolts. Refer to [BR-42, "BRAKE CALIPER ASSEMBLY : Exploded View"](#).
- Install the wheel and tire. Refer to [WT-60, "Removal and Installation"](#).
- Perform the final tightening of nuts and bolts under unladen conditions with tires on level ground.
- Perform the inspection after installation. Refer to [RSU-13, "Inspection"](#).

Removal and Installation - AWD

INFOID:000000009797553

REMOVAL

- Remove wheel and tire using power tool.
- Remove the bolt and separate the rear wheel sensor from the axle housing. Position the rear wheel sensor and harness aside. Refer to [BRC-133, "REAR WHEEL SENSOR : Exploded View"](#).
CAUTION:
 - Failure to remove the rear speed sensor from the axle housing may result in damage to the rear wheel sensor.
 - Pull out the rear wheel sensor, being careful to turn it as little as possible. Do not pull on wheel sensor harness.
- Remove torque member bolts using power tool, leaving the brake hose attached. Position brake caliper aside with wire. Refer to [BRC-133, "REAR WHEEL SENSOR : Exploded View"](#).
CAUTION:
Do not depress brake pedal while brake caliper is removed.
- Put alignment marks on the disc brake rotor and on the wheel hub and bearing. Remove the disc brake rotor.
CAUTION:
Do not drop disc brake rotor.

COIL SPRING

< REMOVAL AND INSTALLATION >

5. Remove the cotter pin.
6. Loosen, but do not remove, the wheel hub and bearing lock nut from the drive shaft using power tool.
7. Tap the wheel hub and bearing lock nut with a piece of wood to disengage the drive shaft from the wheel hub and bearing.

CAUTION:

- Do not place the drive shaft joint at an extreme angle. Be careful not to overextend the slide joint.
- Do not allow the drive shaft to hang without support.

NOTE:

Use a suitable puller if the drive shaft cannot be separated from the wheel hub and bearing.

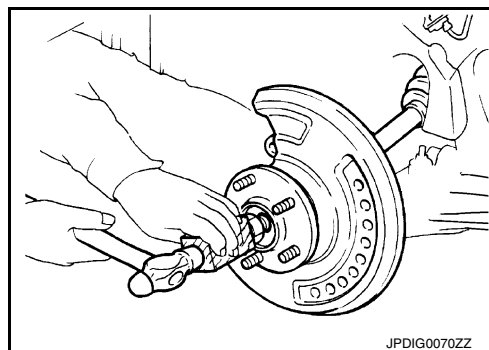

8. Remove the wheel hub and bearing lock nut.
9. Support the rear suspension arm using a suitable jack.

CAUTION:

Do not damage the rear suspension arm with suitable jack.

10. Remove stabilizer connecting rod. Refer to [RSU-21, "Exploded View"](#).
11. Separate the parking brake cable from the rear suspension arm. Refer to [PB-7, "Exploded View"](#).
12. Remove the height sensor (if equipped). Refer to [EXL-271, "Removal and Installation - Rear Height Sensor"](#).
13. Remove the rear shock absorber lower bolt and nut. Separate the rear shock absorber from the rear suspension arm. Refer to [RSU-14, "Exploded View"](#).
14. Remove the upper link bolt and nut from the rear suspension arm. separate the upper link from the rear suspension arm. Refer to [RSU-19, "Exploded View"](#).
15. Loosen the lower link nut at the rear suspension member. Remove the lower link bolt and nut from the rear suspension arm. Separate the lower link from the rear suspension arm. Refer to [RSU-17, "Exploded View"](#).
16. Separate the brake tube from the rear suspension arm. Refer to [BR-24, "REAR : Exploded View"](#).
17. Slowly lower the suitable jack supporting the suspension arm. Remove the upper seat, coil spring and lower seat.

INSTALLATION

1. Align the lower seat indentations (C) with rear suspension arm grooves (B). Install the lower seat protrusion (A) into the hole in the suspension arm.

CAUTION:

The lower rubber seat protrusion must be securely inserted into the hole of rear suspension arm.

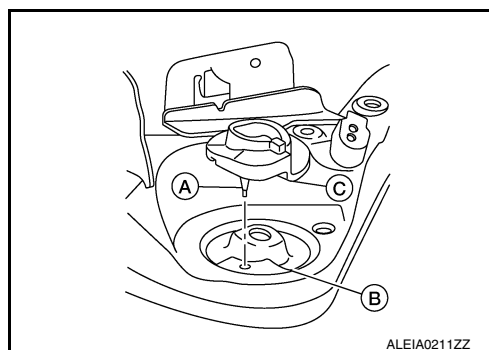

2. Identify the upper side of the coil spring.
NOTE:
 - The top of the coil spring has a flat shape.

COIL SPRING

< REMOVAL AND INSTALLATION >

- The paint identification mark (A) is 1.75 turns from the bottom of the coil spring.

↶ : Upper side

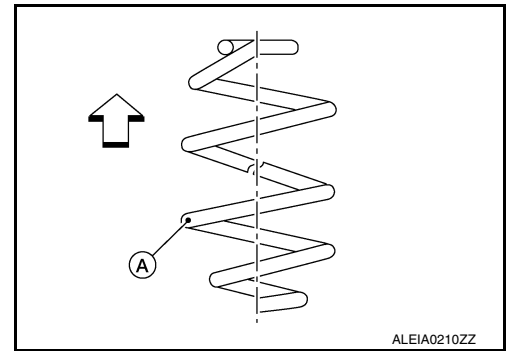

3. Align the coil spring (1) to the lower seat (2). Install coil spring to lower seat.

Maximum distance (A) : 5mm (0.20 in)

CAUTION:

Assemble coil spring so that spring lower end is located in the spring end holding section of lower rubber seat.

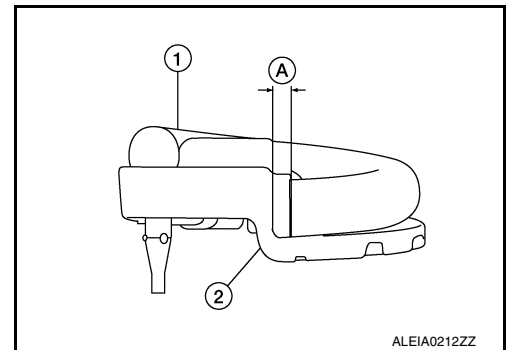

4. Align the coil spring (1) to the upper seat (2). Install the upper seat to the coil spring.

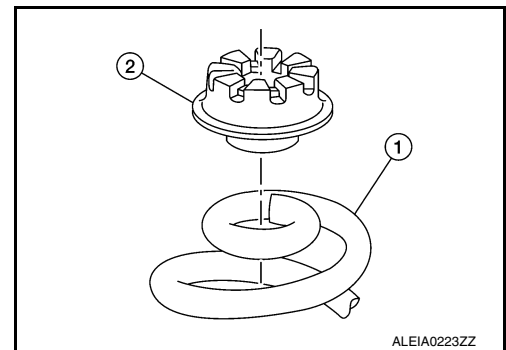

5. Align upper seat (2) to the body (1). Slowly raise the suitable jack supporting the rear suspension arm to install the upper seat to the body.

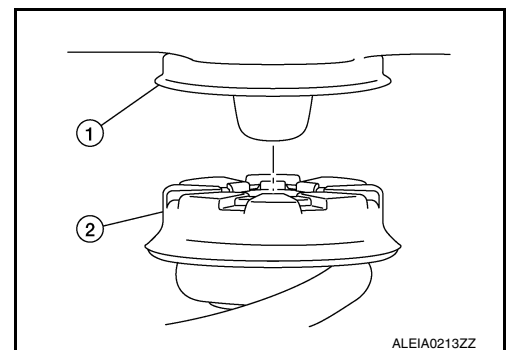

6. Install the brake tube to the rear suspension arm. Refer to [BR-24, "REAR : Exploded View"](#).
7. Install the lower link with the bolt and nut to the rear suspension arm. Refer to [RSU-16, "Exploded View"](#).
NOTE:
The final tightening of nuts and bolts is under unladen conditions with tires on level ground.
8. Install the upper link with the bolt and nut to the rear suspension arm. Refer to [RSU-16, "Exploded View"](#).
9. Install the rear shock absorber with the bolt and nut to the rear suspension arm. Refer to [RSU-8, "Exploded View"](#).
10. Install the height sensor (if equipped) to the rear suspension arm. Refer to [EXL-271, "Removal and Installation - Rear Height Sensor"](#).
11. Install parking brake cable to rear suspension arm. Refer to [PB-7, "Exploded View"](#).

COIL SPRING

< REMOVAL AND INSTALLATION >

12. Install the stabilizer connecting rod. Refer to [EXL-271, "Removal and Installation - Rear Height Sensor"](#).
13. Install the rear wheel sensor to the axle housing. Refer to [BRC-133, "REAR WHEEL SENSOR : Exploded View"](#).
CAUTION:
 - Before installing, make sure there is no foreign material such as iron fragments adhered to the pick-up part of the rear wheel sensor.
 - When installing, make sure there is no foreign material such as iron fragments on and in the hole in the axle housing for the rear wheel sensor. Make sure no foreign material has been caught in the sensor rotor. Remove and foreign material and clean the mount.
14. Align the matching marks on the disc brake rotor and on the wheel hub and bearing. Install the disc brake rotor.
15. Install the brake caliper and the torque member bolts. Refer to [BR-42, "BRAKE CALIPER ASSEMBLY : Exploded View"](#).
16. Install the wheel and tire. Refer to [WT-60, "Removal and Installation"](#).
17. Perform the final tightening of nuts and bolts under unladen conditions with tires on level ground.
18. Perform the inspection after installation. Refer to [RSU-13, "Inspection"](#).

Inspection

INFOID:000000009797554

INSPECTION AFTER REMOVAL

Check lower link, bushing and coil spring for deformation, crack, and damage. Replace components if necessary.

INSPECTION AFTER INSTALLATION

- Check wheel alignment. Refer to [RSU-6, "Inspection"](#).
- Adjust the neutral position of the steering angle sensor. Refer to [BRC-70, "Work Procedure"](#).
- Initialize the headlamp level control unit. Refer to [EXL-115, "Aiming Adjustment Procedure"](#) (HALOGEN HEADLAMP) or [EXL-264, "Aiming Adjustment Procedure"](#) (LED HEADLAMP).

REAR SHOCK ABSORBER

< REMOVAL AND INSTALLATION >

REAR SHOCK ABSORBER

Exploded View

INFOID:000000009797555

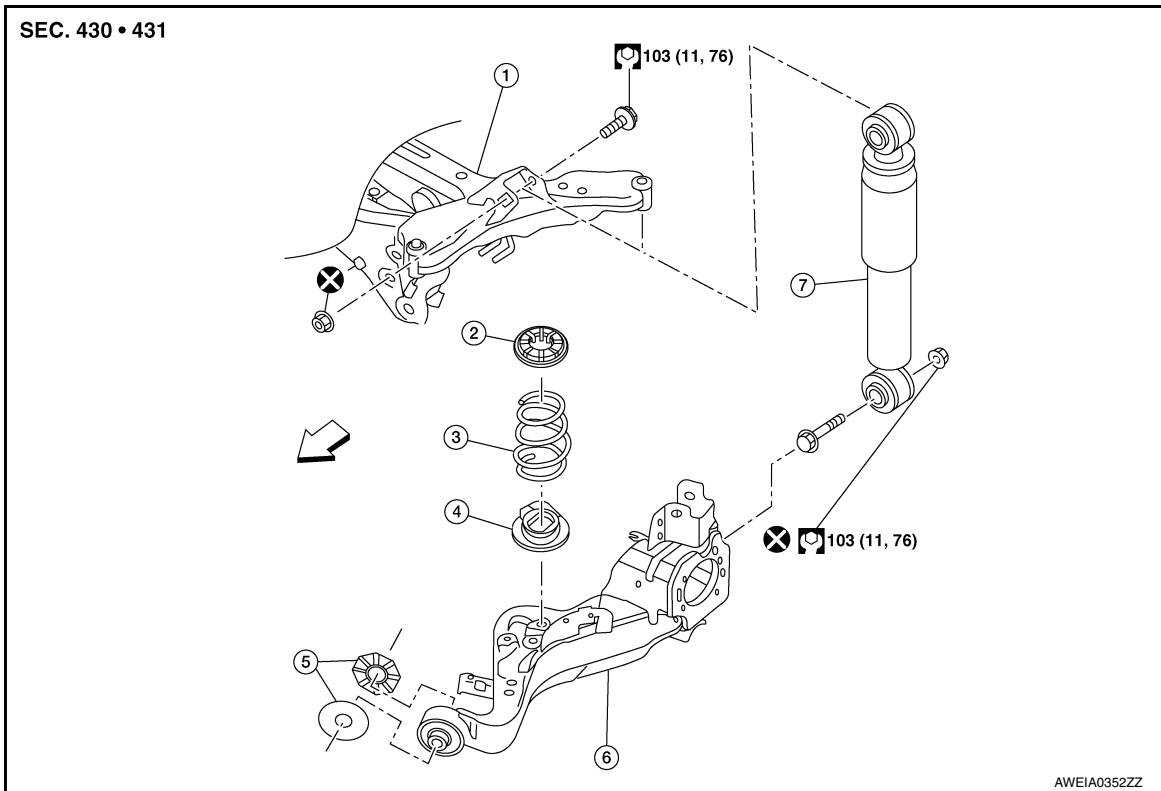

- | | | |
|---------------------------|--------------------------|------------------------|
| 1. Rear suspension member | 2. Upper seat | 3. Coil spring |
| 4. Lower seat | 5. Rubber washer (LH/RH) | 6. Rear suspension arm |
| 7. Rear shock absorber | ↩ Front | |

Removal and Installation

INFOID:000000009797556

REMOVAL

1. Support the rear suspension arm using a suitable jack.
CAUTION:
Do not damage the rear suspension arm with the suitable jack.
2. Remove the lower shock absorber bolt and nut. Separate the shock absorber from the rear suspension arm.
3. Remove the upper bolt, nut, and shock absorber.
4. Inspect the components. Refer to [RSU-5. "Inspection and Adjustment"](#).

INSTALLATION

Installation is in the reverse order of removal.

CAUTION:

Do not reuse the lower shock absorber nut.

- Perform the final tightening of nuts and bolts under unladen conditions with tires on level ground.

Inspection

INFOID:000000009797557

INSPECTION AFTER REMOVAL

- Check shock absorber for deformation, cracks, damage. Replace it if necessary.
- Check welded and sealed areas for oil leaks. Replace it if necessary.

REAR SHOCK ABSORBER

< REMOVAL AND INSTALLATION >

Disposal

INFOID:000000009797558

1. Set shock absorber horizontally to the ground with the piston rod fully extracted.
2. Drill 2 – 3 mm (0.08 – 0.12 in) hole at the position (●) from top as shown in the figure to release gas gradually.

CAUTION:

- **Wear eye protection (safety glasses).**
- **Wear gloves.**
- **Be careful with metal chips or oil blown out by the compressed gas.**

NOTE:

- Drill vertically in this direction (←) directly into the outer tube avoiding brackets.
- The gas is clear, colorless, odorless, and harmless.

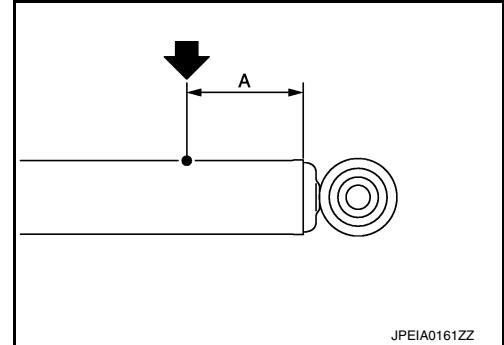

A: 20 – 30 mm (0.79 – 1.18 in)

3. Position the drilled hole downward and drain oil by moving the piston rod several times.

CAUTION:

Dispose of drained oil according to the law and local regulations.

A
B
C
D
RSU
F
G
H
I
J
K
L
M
N
O
P

REAR SUSPENSION ARM

< REMOVAL AND INSTALLATION >

REAR SUSPENSION ARM

Exploded View

INFOID:000000009797559

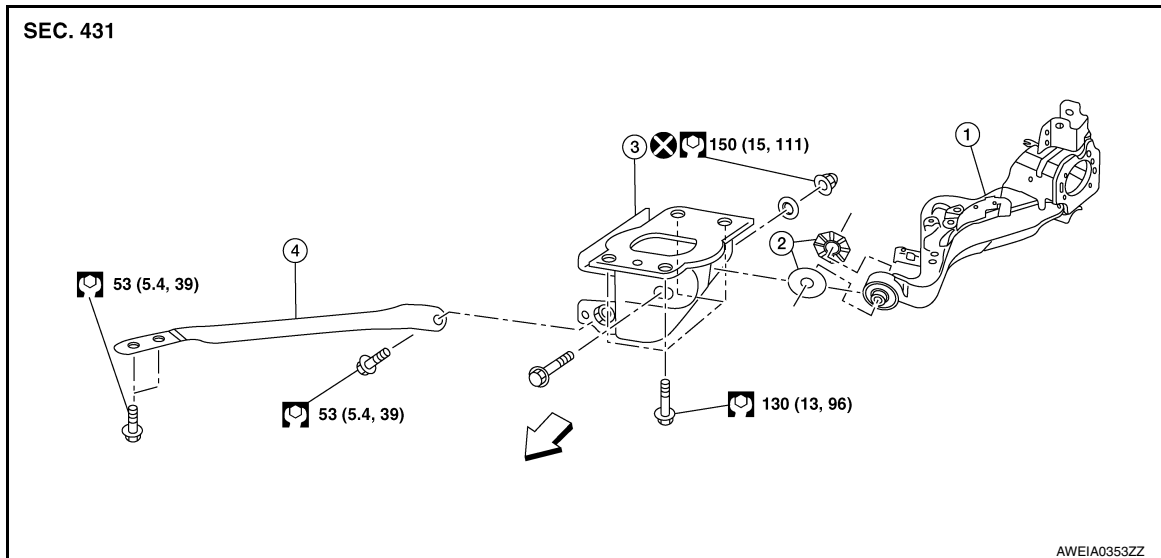

1. Rear suspension arm
 2. Rubber washer (LH/RH)
 3. Rear suspension arm bracket
 4. Rear suspension arm stay
- ⇐ Front

Removal and Installation

INFOID:000000009797560

REMOVAL

1. Remove the wheel hub and bearing. Refer to [RAX-16, "Removal and Installation"](#).
2. Remove the coil spring. [RSU-10, "Removal and Installation - AWD"](#).
3. Separate the brake tube and hose from the rear suspension arm. [BR-24, "REAR : Exploded View"](#).
4. Remove the nut, bolt, rubber washer (LH/RH), and rear suspension arm.
5. Inspect the components. Refer to [RSU-14, "Inspection"](#).

INSTALLATION

Installation is in the reverse order of removal.

- Align the matching marks made during removal when reusing the disc brake rotor.
- After installation, perform the air bleeding. Refer to [BR-16, "Bleeding Brake System"](#).
- Perform final tightening of rear suspension member at its installation position under unladen conditions with tires on level ground.
- Perform the inspection after installation. Refer to [RSU-16, "Inspection"](#).

Inspection

INFOID:000000009797561

INSPECTION AFTER REMOVAL

Visual Inspection

Check rear suspension arm and bushing for deformation, cracks or damage. Replace it if necessary.

INSPECTION AFTER INSTALLATION

1. Adjust parking brake operation (stroke). Refer to [PB-4, "Inspection and Adjustment"](#).
2. Check wheel alignment. Refer to [RSU-6, "Inspection"](#).

LOWER LINK

< REMOVAL AND INSTALLATION >

LOWER LINK

Exploded View

INFOID:000000009797562

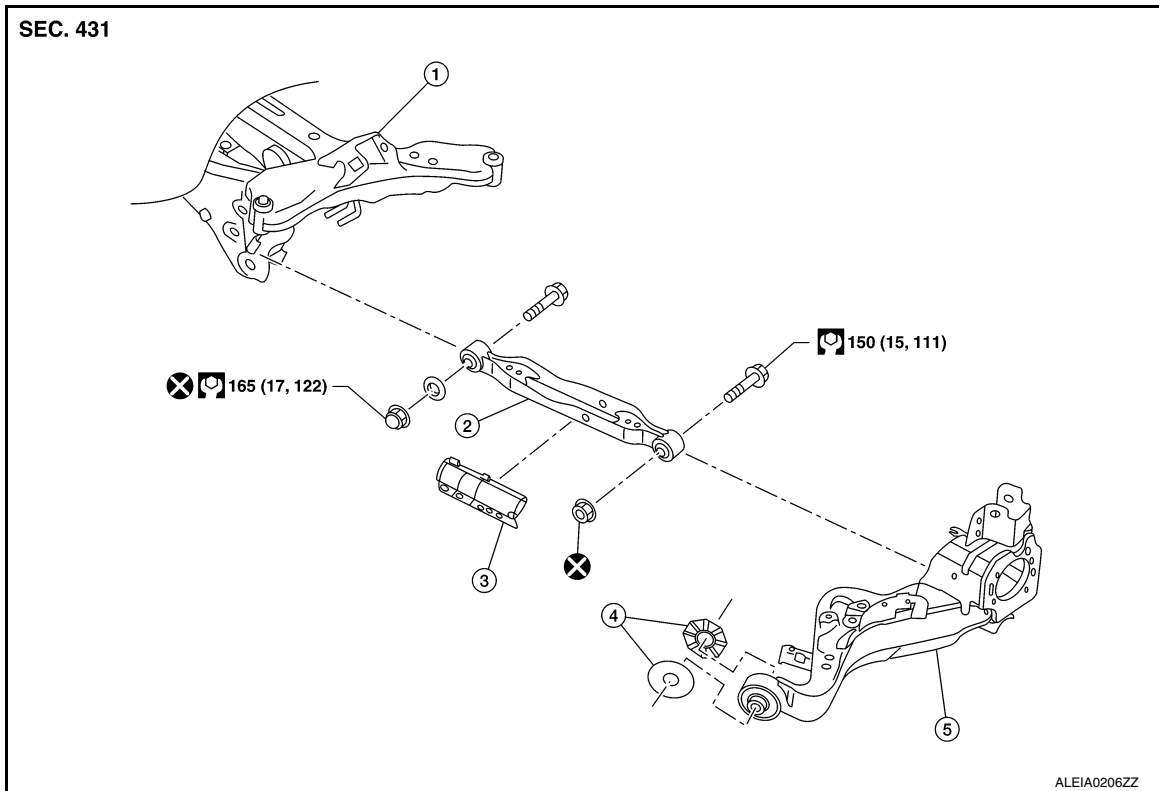

1. Rear suspension member 2. Lower link 3. Lower link deflector
4. Rubber washer (LH/RH) 5. Rear suspension arm ← Front

Removal and Installation

INFOID:000000009797563

REMOVAL

1. Remove wheel and tire using power tool. Refer to [WT-60, "Exploded View"](#).
2. Remove connecting rod. Refer to [RSU-21, "Exploded View"](#).
3. Remove rear height sensor (if equipped). Refer to [EXL-271, "Removal and Installation - Rear Height Sensor"](#).
4. Set suitable jack under rear suspension arm to relieve the coil spring tension.
5. Remove lower link, nut, and bolt from rear suspension arm with power tool.
6. Remove lower link, nut, washer, and bolt from rear suspension member with power tool.
7. Remove lower link protector (if necessary).
8. Perform the inspection after removal. Refer to [RSU-17, "Inspection"](#).

INSTALLATION

Installation is in the reverse order of removal.

- Perform final tightening of rear suspension member and axle installation position under unladen conditions with tires on level ground.
- After installation, perform headlamp initialization. Refer to [EXL-223, "Diagnosis Procedure"](#).
- Adjust the neutral position of the steering angle sensor. Refer to [BRC-70, "Work Procedure"](#).
- Perform the inspection after installation. Refer to [RSU-17, "Inspection"](#).

Inspection

INFOID:000000009797564

INSPECTION AFTER REMOVAL

LOWER LINK

< REMOVAL AND INSTALLATION >

Check lower link and bushing for any deformation, cracks, or damage. Replace it if necessary.

INSPECTION AFTER INSTALLATION

Check wheel alignment. Refer to [RSU-6, "Inspection"](#).

UPPER LINK

< REMOVAL AND INSTALLATION >

UPPER LINK

Exploded View

INFOID:000000009797565

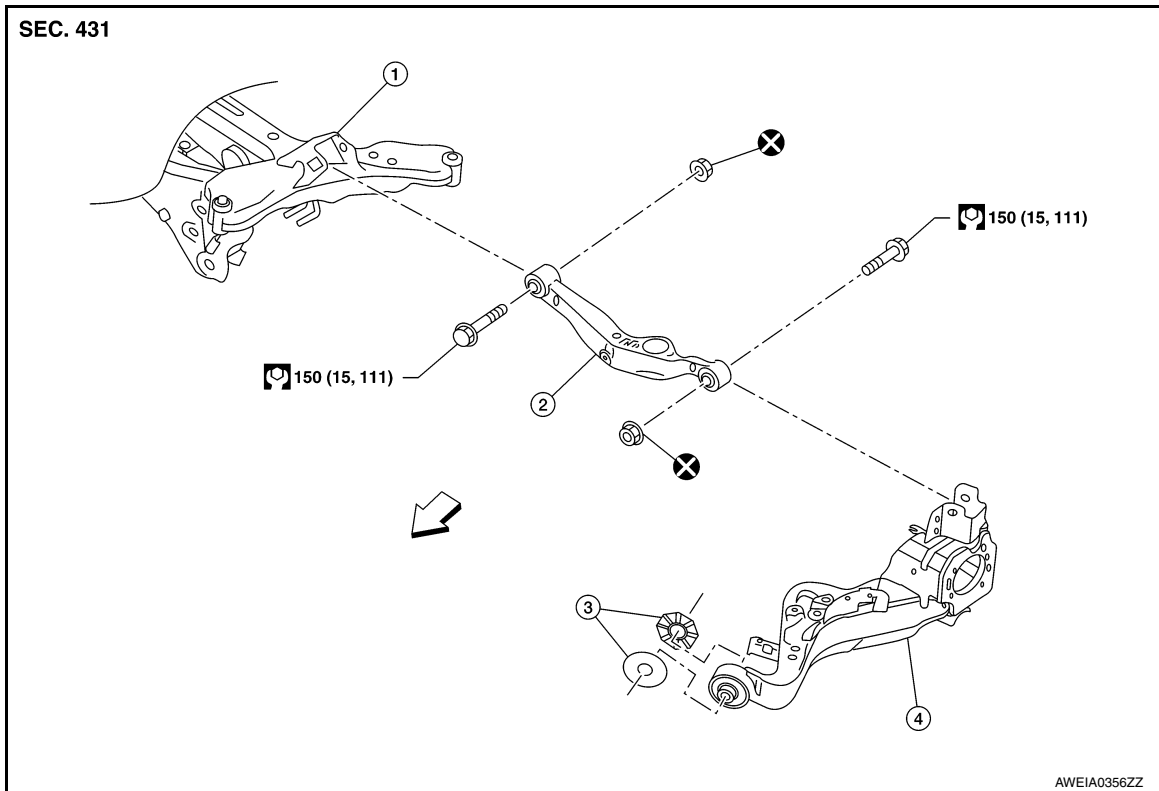

- | | | |
|---------------------------|---------------|--------------------------|
| 1. Rear suspension member | 2. Upper link | 3. Rubber washer (LH/RH) |
| 4. Rear suspension arm | ← Front | |

Removal and Installation

INFOID:000000009797566

REMOVAL

1. Remove wheel and tire using power tool. Refer to [WT-60, "Exploded View"](#)
2. Remove rear wheel sensor and harness from rear suspension arm. Refer to [BRC-133, "REAR WHEEL SENSOR : Exploded View"](#).
CAUTION:
Do not pull on rear wheel sensor harness. Refer to [BRC-135, "REAR SENSOR ROTOR : Removal and Installation - Rear Sensor Rotor"](#)
3. Remove height sensor (if equipped).
4. Disconnect harness connector from the height sensor (if equipped). Refer to [EXL-271, "Removal and Installation - Rear Height Sensor"](#).
5. Set suitable jack under rear suspension arm to relieve the coil spring tension.
6. Remove upper link, nut, and bolt from suspension arm with power tool.
7. Remove upper link, nut, and bolt from suspension member with power tool.
8. Perform the inspection after removal. Refer to [RSU-20, "Inspection"](#).

INSTALLATION

Installation is in the reverse order of removal.

- Perform final tightening of rear suspension member and axle installation position under unladen conditions with tires on level ground.
- After installation, perform headlamp initialization. Refer to [EXL-223, "Diagnosis Procedure"](#).
- Adjust the neutral position of the steering angle sensor. Refer to [BRC-70, "Work Procedure"](#).
- Perform the inspection after installation. Refer to [RSU-20, "Inspection"](#).

UPPER LINK

< REMOVAL AND INSTALLATION >

Inspection

INFOID:000000009797567

INSPECTION AFTER REMOVAL

Check upper link and bushing for any deformation, cracks, or damage. Replace it if necessary.

INSPECTION AFTER INSTALLATION

Check wheel alignment. Refer to [RSU-6, "Inspection"](#).

REAR STABILIZER

< REMOVAL AND INSTALLATION >

REAR STABILIZER

Exploded View

INFOID:000000009797568

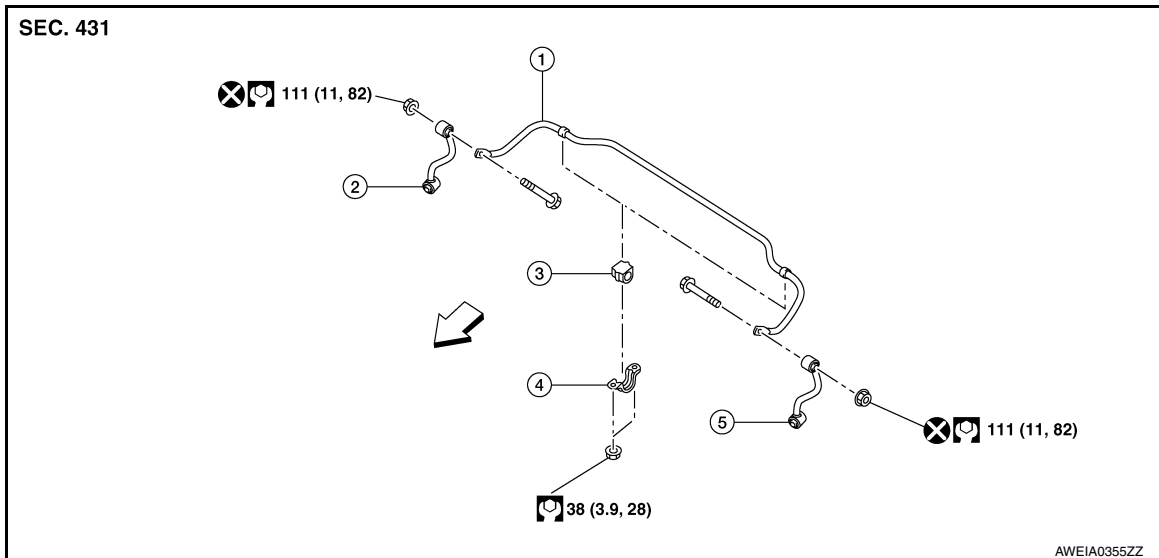

- | | | |
|------------------------------|------------------------|--------------------------------|
| 1. Rear stabilizer bar | 2. Connecting rod (RH) | 3. Rear stabilizer bar bushing |
| 4. Rear stabilizer bar clamp | 5. Connecting rod (LH) | ⇐ Front |

Removal and Installation

INFOID:000000009797569

REMOVAL

1. Disconnect rear stabilizer links from rear stabilizer bar.
2. Remove nuts on rear stabilizer clamp.
3. Remove rear stabilizer bar from rear suspension member.
4. Remove rear stabilizer bushings from rear stabilizer bar (if necessary).
5. Perform the inspection after removal. Refer to [RSU-21, "Inspection"](#).

INSTALLATION

Installation is in the reverse order of removal.

Inspection

INFOID:000000009797570

INSPECTION AFTER REMOVAL

Check rear stabilizer bar, rear stabilizer link, rear stabilizer bushing and rear stabilizer clamp for deformation, cracks or damage. Replace it if necessary.

REAR SUSPENSION MEMBER

< UNIT REMOVAL AND INSTALLATION >

UNIT REMOVAL AND INSTALLATION

REAR SUSPENSION MEMBER

Exploded View

INFOID:000000009797571

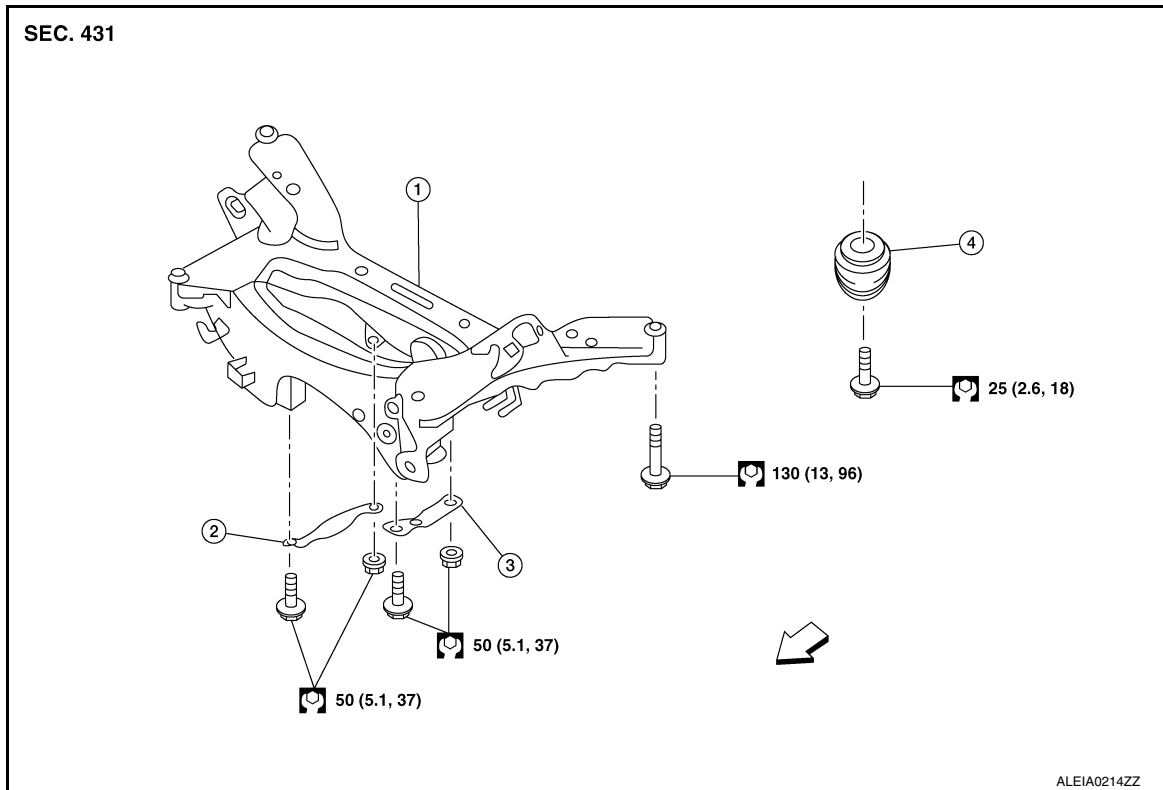

- | | | |
|---------------------------|--------------------------------|--------------------------------|
| 1. Rear suspension member | 2. Suspension member stay (RH) | 3. Suspension member stay (LH) |
| 4. Bound bumper | ↩ Front | |

Removal and Installation - FWD

INFOID:000000010350731

REMOVAL

1. Remove wheel and tires using power tool. Refer to [WT-60. "Exploded View"](#).
2. Remove muffler assembly. Refer to [EX-5. "Exploded View"](#).
3. Remove coil spring. Refer to [RSU-8. "Removal and Installation - FWD"](#).
4. Remove lower link. Refer to [RSU-17. "Removal and Installation"](#).
5. Remove upper link. Refer to [BR-43. "BRAKE CALIPER ASSEMBLY : Removal and Installation"](#).
6. Remove rear stabilizer bar. Refer to [RSU-21. "Removal and Installation"](#).
7. Remove rear shock absorber. Refer to [RSU-14. "Removal and Installation"](#).
8. Set suitable jack under rear suspension member.
9. Remove bolts from rear suspension member.
10. Slowly lower suitable jack and remove rear suspension member.

CAUTION:

Secure suspension assembly to a suitable jack while removing it.

INSTALLATION

Installation is in the reverse order of the removal.

- When installing suspension member stay, face each arrow on the part toward the inside of the vehicle.
- Align the matching marks made during removal when reusing the disc brake rotor.

REAR SUSPENSION MEMBER

< UNIT REMOVAL AND INSTALLATION >

- Perform the final tightening of each parts removed when removing rear suspension assembly under unladen conditions.
- Check wheel sensor harness for proper connection. Refer to [BRC-133, "REAR WHEEL SENSOR : Exploded View"](#).

Removal and Installation - AWD

INFOID:000000009797572

REMOVAL

1. Remove wheel and tires using power tool. Refer to [WT-60, "Exploded View"](#).
2. Remove muffler assembly. Refer to [EX-5, "Exploded View"](#).
3. Remove coil spring. Refer to [RSU-10, "Removal and Installation - AWD"](#).
4. Remove lower link. Refer to [RSU-17, "Removal and Installation"](#).
5. Remove upper link. Refer to [BR-43, "BRAKE CALIPER ASSEMBLY : Removal and Installation"](#).
6. Remove rear stabilizer bar. Refer to [RSU-21, "Removal and Installation"](#).
7. Remove rear drive shaft. Refer to [RAX-19, "Removal and Installation"](#).
8. Remove rear propeller shaft. Refer to [DLN-99, "Removal and Installation"](#).
9. Remove rear final drive. Refer to [DLN-119, "Removal and Installation"](#).
10. Remove rear shock absorber. Refer to [RSU-14, "Removal and Installation"](#).
11. Set suitable jack under rear suspension member.
12. Remove bolts from rear suspension member.
13. Slowly lower suitable jack and remove rear suspension member.
CAUTION:
Secure suspension assembly to a suitable jack while removing it.
14. Perform the inspection after removal. Refer to [RSU-23, "Inspection"](#).

INSTALLATION

Installation is in the reverse order of the removal.

- When installing suspension member stay, face each arrow on the part toward the inside of the vehicle.
- Align the matching marks made during removal when reusing the disc brake rotor.
- Perform the final tightening of each parts removed when removing rear suspension assembly under unladen conditions.
- Check wheel sensor harness for proper connection. Refer to [BRC-133, "REAR WHEEL SENSOR : Exploded View"](#).
- Perform the inspection after installation. Refer to [RSU-20, "Inspection"](#).

Inspection

INFOID:000000009797573

INSPECTION AFTER REMOVAL

Check rear suspension member for deformation, cracks, or any other damage. Replace it if necessary.

INSPECTION AFTER INSTALLATION

1. Adjust parking brake operation. Refer to [PB-4, "Inspection and Adjustment"](#).
2. Check wheel alignment. Refer to [RSU-6, "Inspection"](#).

SERVICE DATA AND SPECIFICATIONS (SDS)

< SERVICE DATA AND SPECIFICATIONS (SDS)

SERVICE DATA AND SPECIFICATIONS (SDS)

SERVICE DATA AND SPECIFICATIONS (SDS)

Wheel Alignment (Unladen*¹)

INFOID:000000010275666

Drive Type		FWD	AWD
Camber Degree minute (Decimal degree)	Minimum	-0° 10' (-0.17°)	0° 10' (0.17°)
	Nominal	-0° 55' (-0.92°)	-0° 35' (-0.58°)
	Maximum	-1° 40' (-1.67°)	-1° 20' (-1.33°)

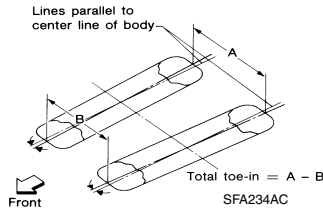

Total toe-in	Distance (A - B)	Minimum	In 2 mm (In 0.08 in)	
		Nominal	In 4 mm (In 0.12 in)	In 2.0 mm (0.08 in)
		Maximum	In 6 mm (In 0.24in)	
	Angle (LH and RH) ^{*2} Degree minute (Decimal degree)	Minimum	In 0° 10' (In 0.17°)	Out 0° 15' (Out 0.25°)
		Nominal	In 0° 20' (In 0.33°)	In 0° 10' (In 0.17°)
		Maximum	In 0° 30' (In 0.50°)	In 0° 35' (In 0.58°)

*1: Fuel, engine coolant, and lubricants are full. Spare tire, jack, hand tools, and mats are in designated positions.

*2: Since an adjustment mechanism is not included, the value of the left and right wheels must be used as the standard value.

Wheelarch Height (Unladen*)

INFOID:000000010275667

Unit: mm (in)

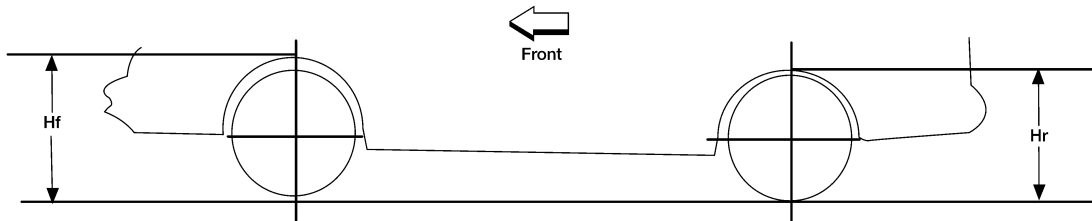

LEIA0085E

Axle type	FWD			AWD		
	2 ROW		3 ROW	2 ROW		3 ROW
Tire size	225/65R17	225/60R18	225/65R17 RF	225/65R17	225/60R18	225/65R17 RF
Front (Hf)	788 (31.02)	792 (31.18)	791 (31.14)	798 (31.42)	801 (31.54)	801 (31.54)
Rear (Hr)	787 (30.98)	789 (31.06)	787 (30.98)	796 (31.34)	798 (31.42)	796 (31.34)

*: Fuel, engine coolant, and lubricants are full. Spare tire, jack, hand tools, and mats are in designated positions.