

A  
B  
C  
D  
E

# SECTION **BRC**

## BRAKE CONTROL SYSTEM

### CONTENTS

		<b>BRC</b>
<b>VDC/TCS/ABS</b>		
<b>PRECAUTION</b> .....	<b>ABS FUNCTION</b> .....	
4	27	
	ABS FUNCTION : System Description .....	28
<b>PRECAUTIONS</b> .....	<b>EBD FUNCTION</b> .....	
4	29	
Caution for Supplemental Restraint System (SRS) "AIR BAG" and "SEAT BELT PRE-TEN- SIONER" .....	EBD FUNCTION : System Description .....	29
4		
Caution for Procedure without Cowl Top Cover.....	<b>BRAKE LIMITED SLIP DIFFERENTIAL (BLSD) FUNCTION</b> .....	30
4	BRAKE LIMITED SLIP DIFFERENTIAL (BLSD) FUNCTION : System Description .....	30
Caution for Brake System .....		
4	<b>BRAKE ASSIST FUNCTION</b> .....	31
Caution for Brake Control System .....	BRAKE ASSIST FUNCTION : System Description .....	32
5		
Caution for Harness Repair .....	<b>HILL DESCENT CONTROL (DOWNHILL DRIVE SUPPORT) FUNCTION</b> .....	33
5	hill descent control (Downhill Drive Support) FUNCTION : System Diagram .....	33
<b>PREPARATION</b> .....	hill descent control (Downhill Drive Support) FUNCTION : System Description .....	33
6		
<b>PREPARATION</b> .....	<b>HILL START ASSIST FUNCTION</b> .....	34
6	hill start assist FUNCTION : System Description ....	34
Special Service Tool .....		
6	<b>BRAKE FORCE DISTRIBUTION FUNCTION</b> .....	35
Commercial Service Tools .....	BRAKE FORCE DISTRIBUTION FUNCTION : System Description .....	35
6		
<b>SYSTEM DESCRIPTION</b> .....	<b>ACTIVE TRACE CONTROL FUNCTION</b> .....	37
7	ACTIVE TRACE CONTROL FUNCTION : System Description .....	37
<b>COMPONENT PARTS</b> .....	<b>WARNING/INDICATOR/CHIME LIST</b> .....	40
7	WARNING/INDICATOR/CHIME LIST : Warning Lamp/Indicator Lamp .....	40
Component Parts Location .....		
7	<b>DIAGNOSIS SYSTEM [ABS ACTUATOR AND ELECTRIC UNIT (CONTROL UNIT)]</b> .....	42
Wheel Sensor and Sensor Rotor .....	CONSULT Function .....	42
9		
ABS Actuator and Electric Unit (Control Unit) .....	<b>ECU DIAGNOSIS INFORMATION</b> .....	47
9		
Stop Lamp Switch .....		
10		
Steering Angle Sensor .....		
10		
Brake Fluid Level Switch .....		
10		
Vacuum Sensor .....		
11		
Parking Brake Switch .....		
11		
VDC OFF Switch .....		
11		
Hill Descent Control Switch .....		
11		
<b>SYSTEM</b> .....		
12		
System Description .....		
12		
Fail-Safe .....		
20		
<b>VDC FUNCTION</b> .....		
23		
VDC FUNCTION : System Description .....		
23		
<b>TCS FUNCTION</b> .....		
26		
TCS FUNCTION : System Description .....		
26		

<b>ABS ACTUATOR AND ELECTRIC UNIT (CONTROL UNIT)</b> .....	<b>47</b>	<b>C1120, C1122, C1124, C1126 ABS IN VALVE SYSTEM</b> .....	<b>85</b>
Reference Value .....	47	DTC Logic .....	85
Fail-Safe .....	49	Diagnosis Procedure .....	85
DTC Inspection Priority Chart .....	52	<b>C1121, C1123, C1125, C1127 ABS OUT VALVE SYSTEM</b> .....	<b>87</b>
DTC Index .....	53	DTC Logic .....	87
<b>WIRING DIAGRAM</b> .....	<b>55</b>	Diagnosis Procedure .....	87
<b>BRAKE CONTROL SYSTEM</b> .....	<b>55</b>	<b>C1130 ENGINE SIGNAL</b> .....	<b>89</b>
Wiring Diagram .....	55	DTC Logic .....	89
<b>BASIC INSPECTION</b> .....	<b>64</b>	Diagnosis Procedure .....	89
<b>DIAGNOSIS AND REPAIR WORK FLOW</b> .....	<b>64</b>	<b>C1140 ACTUATOR RELAY SYSTEM</b> .....	<b>90</b>
Work Flow .....	64	DTC Logic .....	90
Diagnostic Work Sheet .....	65	Diagnosis Procedure .....	90
<b>ADDITIONAL SERVICE WHEN REPLACING ABS ACTUATOR AND ELECTRIC UNIT (CONTROL UNIT)</b> .....	<b>67</b>	<b>C1142 PRESS SENSOR</b> .....	<b>92</b>
Description .....	67	DTC Logic .....	92
<b>ADJUSTMENT OF STEERING ANGLE SENSOR NEUTRAL POSITION</b> .....	<b>68</b>	Diagnosis Procedure .....	92
Description .....	68	<b>C1143 STEERING ANGLE SENSOR</b> .....	<b>94</b>
Work Procedure .....	68	DTC Logic .....	94
<b>CALIBRATION OF DECEL G SENSOR</b> .....	<b>70</b>	Diagnosis Procedure .....	94
Description .....	70	<b>C1144 INCOMPLETE STEERING ANGLE SENSOR ADJUSTMENT</b> .....	<b>96</b>
Work Procedure .....	70	DTC Logic .....	96
<b>DTC/CIRCUIT DIAGNOSIS</b> .....	<b>72</b>	Diagnosis Procedure .....	96
<b>C1101, C1102, C1103, C1104 WHEEL SENSOR</b> .....	<b>72</b>	<b>C1155 BRAKE FLUID LEVEL SWITCH</b> .....	<b>97</b>
DTC Logic .....	72	DTC Logic .....	97
Diagnosis Procedure .....	72	Diagnosis Procedure .....	97
<b>C1105, C1106, C1107, C1108 WHEEL SENSOR</b> .....	<b>76</b>	Component Inspection .....	98
DTC Logic .....	76	<b>C1160 DECEL G SEN SET</b> .....	<b>99</b>
Diagnosis Procedure .....	76	DTC Logic .....	99
<b>C1109 POWER AND GROUND SYSTEM</b> .....	<b>78</b>	Diagnosis Procedure .....	99
DTC Logic .....	78	<b>C1164, C1165 CV SYSTEM</b> .....	<b>100</b>
Diagnosis Procedure .....	78	DTC Logic .....	100
<b>C1111 PUMP MOTOR</b> .....	<b>80</b>	Diagnosis Procedure .....	100
DTC Logic .....	80	<b>C1170 VARIANT CODING</b> .....	<b>102</b>
Diagnosis Procedure .....	80	DTC Logic .....	102
<b>C1113, C1145, C1146 YAW RATE/SIDE/DECEL G SENSOR</b> .....	<b>82</b>	Diagnosis Procedure .....	102
DTC Logic .....	82	<b>C1197 VACUUM SENSOR</b> .....	<b>103</b>
Diagnosis Procedure .....	82	DTC Logic .....	103
<b>C1115 ABS SENSOR [ABNORMAL SIGNAL]</b> ..	<b>83</b>	Diagnosis Procedure .....	103
DTC Logic .....	83	<b>C1198 VACUUM SENSOR</b> .....	<b>105</b>
Diagnosis Procedure .....	83	DTC Logic .....	105
		Diagnosis Procedure .....	105
		<b>C1199 BRAKE BOOSTER</b> .....	<b>107</b>
		DTC Logic .....	107
		Diagnosis Procedure .....	107
		<b>C119A VACUUM SENSOR</b> .....	<b>109</b>
		DTC Logic .....	109

Diagnosis Procedure .....	109	<b>BRAKE PEDAL VIBRATION OR OPERATION SOUND OCCURS .....</b>	<b>127</b>	A
<b>U1000 CAN COMM CIRCUIT .....</b>	<b>111</b>	Description .....	127	
Description .....	111	Diagnosis Procedure .....	127	
DTC Logic .....	111	<b>VEHICLE JERKS DURING .....</b>	<b>128</b>	B
Diagnosis Procedure .....	111	Description .....	128	
<b>POWER SUPPLY AND GROUND CIRCUIT ...</b>	<b>112</b>	Diagnosis Procedure .....	128	
Diagnosis Procedure .....	112	<b>NORMAL OPERATING CONDITION .....</b>	<b>129</b>	C
<b>PARKING BRAKE SWITCH .....</b>	<b>113</b>	Description .....	129	
Component Function Check .....	113	<b>REMOVAL AND INSTALLATION .....</b>	<b>130</b>	D
Diagnosis Procedure .....	113	<b>WHEEL SENSOR .....</b>	<b>130</b>	E
Component Inspection .....	114	<b>FRONT WHEEL SENSOR .....</b>	<b>130</b>	
<b>VDC OFF SWITCH .....</b>	<b>115</b>	FRONT WHEEL SENSOR : Exploded View .....	130	
Component Function Check .....	115	FRONT WHEEL SENSOR : Removal and Installation .....	130	BRC
Diagnosis Procedure .....	115	<b>REAR WHEEL SENSOR .....</b>	<b>131</b>	
Component Inspection .....	116	REAR WHEEL SENSOR : Exploded View .....	131	G
<b>ABS WARNING LAMP .....</b>	<b>117</b>	REAR WHEEL SENSOR : Removal and Installation .....	132	
Component Function Check .....	117	<b>SENSOR ROTOR .....</b>	<b>133</b>	H
Diagnosis Procedure .....	117	<b>FRONT SENSOR ROTOR .....</b>	<b>133</b>	
<b>BRAKE WARNING LAMP .....</b>	<b>118</b>	FRONT SENSOR ROTOR : Removal and Installation - Front Sensor Rotor .....	133	I
Component Function Check .....	118	<b>REAR SENSOR ROTOR .....</b>	<b>133</b>	
Diagnosis Procedure .....	118	REAR SENSOR ROTOR : Removal and Installation - Rear Sensor Rotor .....	133	J
<b>VDC WARNING LAMP .....</b>	<b>120</b>	<b>ABS ACTUATOR AND ELECTRIC UNIT (CONTROL UNIT) .....</b>	<b>134</b>	K
Component Function Check .....	120	Exploded View .....	134	
Diagnosis Procedure .....	120	Removal and Installation .....	134	L
<b>VDC OFF INDICATOR LAMP .....</b>	<b>121</b>	<b>VDC OFF SWITCH .....</b>	<b>136</b>	
Component Function Check .....	121	Exploded View .....	136	M
Diagnosis Procedure .....	121	Removal and Installation .....	136	
<b>SYMPTOM DIAGNOSIS .....</b>	<b>122</b>	<b>STEERING ANGLE SENSOR .....</b>	<b>137</b>	N
<b>EXCESSIVE OPERATION FREQUENCY .....</b>	<b>122</b>	Exploded View .....	137	
Description .....	122	Removal and Installation .....	137	O
Diagnosis Procedure .....	122	<b>HILL DESCENT CONTROL SWITCH .....</b>	<b>138</b>	
<b>UNEXPECTED BRAKE PEDAL REACTION ..</b>	<b>124</b>	Exploded View .....	138	
Description .....	124	Removal and Installation .....	138	P
Diagnosis Procedure .....	124			
<b>THE BRAKING DISTANCE IS LONG .....</b>	<b>125</b>			
Description .....	125			
Diagnosis Procedure .....	125			
<b>DOES NOT OPERATE .....</b>	<b>126</b>			
Description .....	126			
Diagnosis Procedure .....	126			

## PRECAUTION

### PRECAUTIONS

#### Precaution for Supplemental Restraint System (SRS) "AIR BAG" and "SEAT BELT PRE-TENSIONER"

INFOID:000000011280552

The Supplemental Restraint System such as "AIR BAG" and "SEAT BELT PRE-TENSIONER", used along with a front seat belt, helps to reduce the risk or severity of injury to the driver and front passenger for certain types of collision. Information necessary to service the system safely is included in the SR and SB section of this Service Manual.

**WARNING:**

- To avoid rendering the SRS inoperative, which could increase the risk of personal injury or death in the event of a collision which would result in air bag inflation, all maintenance must be performed by an authorized NISSAN/INFINITI dealer.
- Improper maintenance, including incorrect removal and installation of the SRS, can lead to personal injury caused by unintentional activation of the system. For removal of Spiral Cable and Air Bag Module, see the SR section.
- Do not use electrical test equipment on any circuit related to the SRS unless instructed to in this Service Manual. SRS wiring harnesses can be identified by yellow and/or orange harnesses or harness connectors.

#### PRECAUTIONS WHEN USING POWER TOOLS (AIR OR ELECTRIC) AND HAMMERS

**WARNING:**

- When working near the Airbag Diagnosis Sensor Unit or other Airbag System sensors with the Ignition ON or engine running, DO NOT use air or electric power tools or strike near the sensor(s) with a hammer. Heavy vibration could activate the sensor(s) and deploy the air bag(s), possibly causing serious injury.
- When using air or electric power tools or hammers, always switch the Ignition OFF, disconnect the battery and wait at least three minutes before performing any service.

#### Precaution for Procedure without Cowl Top Cover

INFOID:000000011280553

When performing the procedure after removing cowl top cover, cover the lower end of windshield with urethane, etc. to prevent damage to windshield.

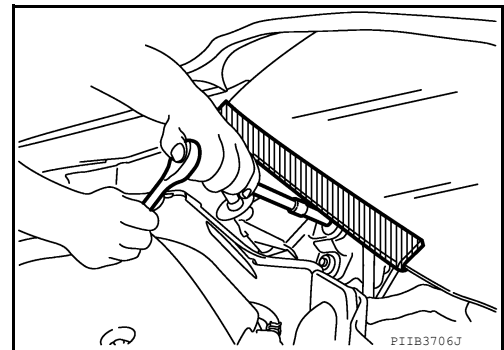

#### Precaution for Brake System

INFOID:000000011280554

**WARNING:**

Clean any dust from the front brake and rear brake using a vacuum dust collector. Do not blow by compressed air.

- Brake fluid use refer to [MA-11. "Fluids and Lubricants"](#).
- Do not reuse drained brake fluid.
- Do not spill or splash brake fluid on painted surfaces. Brake fluid may seriously damage paint. Wipe it off immediately and wash with water if it gets on a painted surface.
- Always confirm the specified tightening torque when installing the brake pipes.
- After pressing the brake pedal more deeply or harder than normal driving, such as air bleeding, check each item of brake pedal. Adjust brake pedal if it is outside the standard value.
- Do not use mineral oils such as gasoline or light oil to clean. They may damage rubber parts and cause improper operation.
- Always loosen the brake tube flare nut with a flare nut wrench.

# PRECAUTIONS

[VDC/TCS/ABS]

## < PRECAUTION >

- Tighten the brake tube flare nut to the specified torque with a flare nut crowfoot (A) and torque wrench (B).
- Always connect the battery terminal when moving the vehicle.
- Turn the ignition switch OFF and disconnect the ABS actuator and electric unit (control unit) harness connector or the battery negative terminal before performing the work.
- Check that no brake fluid leakage is present after replacing the parts.

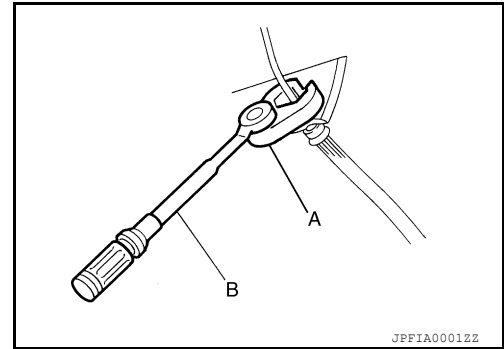

## Precaution for Brake Control System

INFOID:000000011280555

- Just after starting vehicle after ignition switch is ON, brake pedal may vibrate or motor operating noise may be heard from engine compartment. This is a normal condition.
- When an error is indicated by ABS or another warning lamp, collect all necessary information from customer (what symptoms are present under what conditions) and check for simple causes before starting diagnostic servicing. Besides electrical system inspection, check brake booster operation, brake fluid level and oil leaks.
- If tire size and type are used in an improper combination or brake pads are not Genuine NISSAN parts, stopping distance or steering stability may deteriorate.
- ABS might be out of order or malfunctions by putting a radio (wiring inclusive), an antenna and a lead-in wire near the control unit.
- If aftermarket parts (car stereo, CD player, etc.) have been installed, check for incidents such as harness pinches, open circuits, and improper wiring.
- VDC system may not operate normally or a VDC OFF indicator lamp or SLIP indicator lamp may light.
- When replacing the following parts with parts other than genuine parts or making modifications: Suspension-related parts (shock absorber, spring, bushing, etc.), tires, wheels (other than specified sizes), brake-related parts (pad, rotor, caliper, etc.), engine-related parts (muffler, ECM, etc.) and body reinforcement-related parts (roll bar, tower bar, etc.).
- When driving with worn or deteriorated suspension, tires and brake-related parts.

## Precaution for Harness Repair

INFOID:000000011280556

- Solder the repair part, and wrap it with tape. [Twisted wire fray must be 110 mm (4.33 in) or less.]

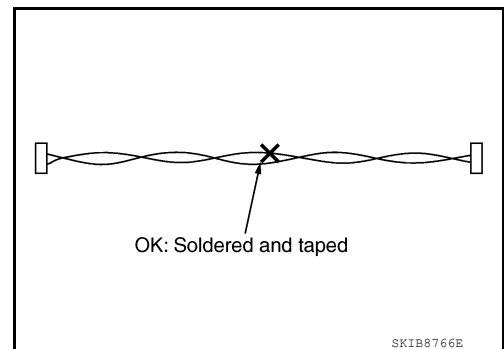

- Do not bypass the repair point with wire. (If it is bypassed, the turn-out point cannot be separated and the twisted wire characteristics are lost.)

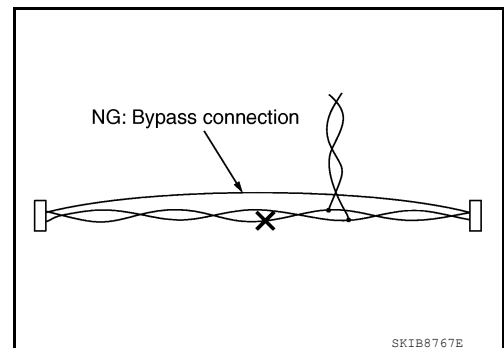

# PREPARATION

< PREPARATION >

[VDC/TCS/ABS]

## PREPARATION

### PREPARATION

#### Special Service Tool

INFOID:000000011280557

The actual shape of the tools may differ from those illustrated here.

Tool number (TechMate No.) Tool name	Description
KV991J0080 (J-45741) ABS active wheel sensor tester	Checking operation of ABS active wheel sensors

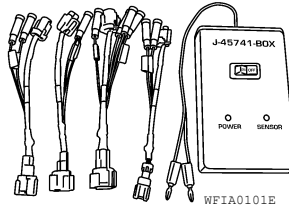

WFIA0101E

#### Commercial Service Tools

INFOID:000000011280558

Tool name	Description
1. Flare nut crowfoot 2. Torque wrench	Tightening brake tube flare nuts a: 10 mm (0.39 in)/12 mm (0.47 in)
Power tool	Loosening nuts, screws and bolts

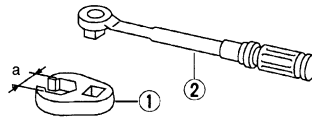

S-NT360



PIIB1407E

# COMPONENT PARTS

< SYSTEM DESCRIPTION >

[VDC/TCS/ABS]

## SYSTEM DESCRIPTION

### COMPONENT PARTS

#### Component Parts Location

INFOID:0000000011280559

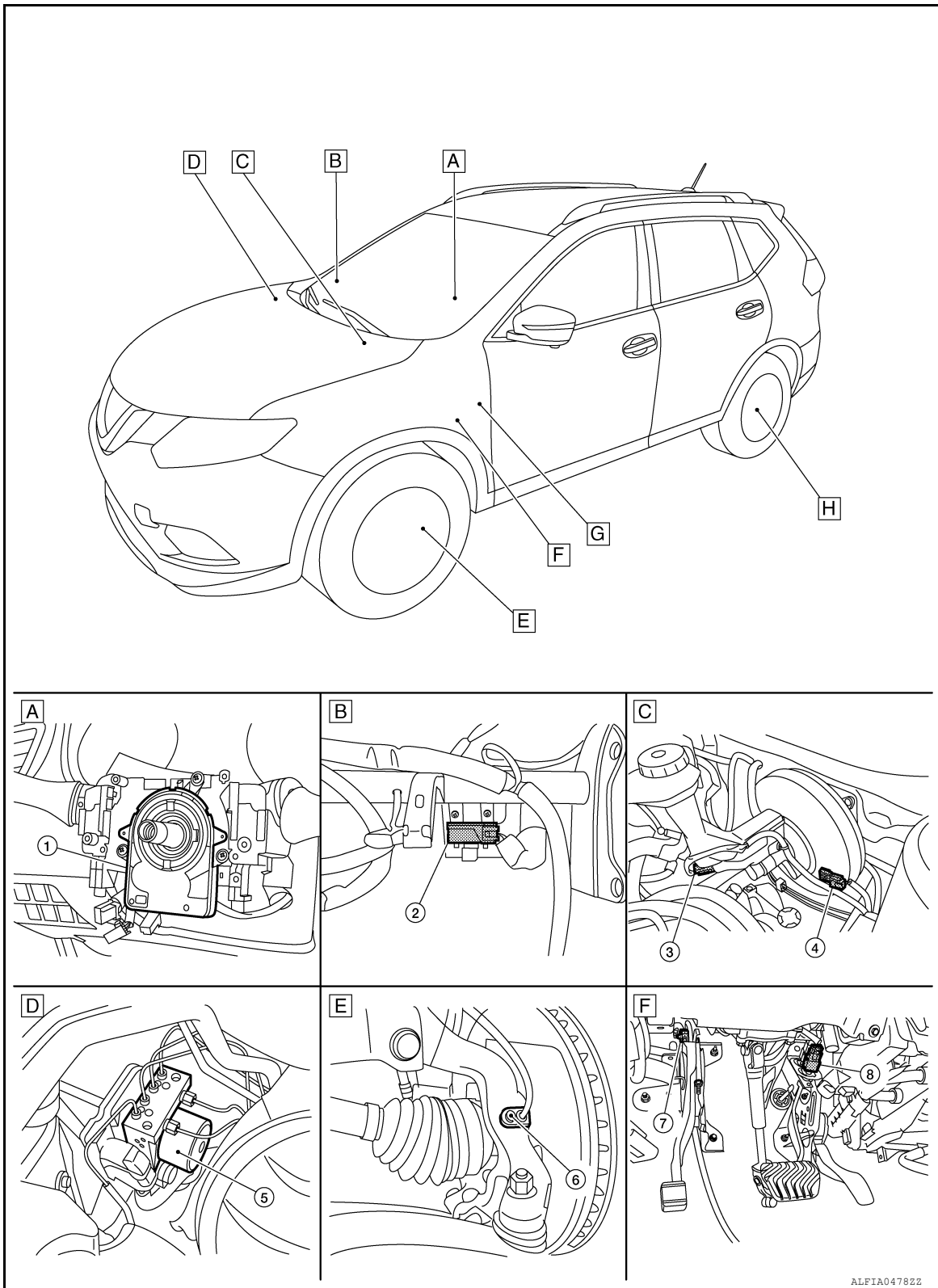

A  
B  
C  
D  
E  
BRC  
G  
H  
I  
J  
K  
L  
M  
N  
O  
P

# COMPONENT PARTS

< SYSTEM DESCRIPTION >

[VDC/TCS/ABS]

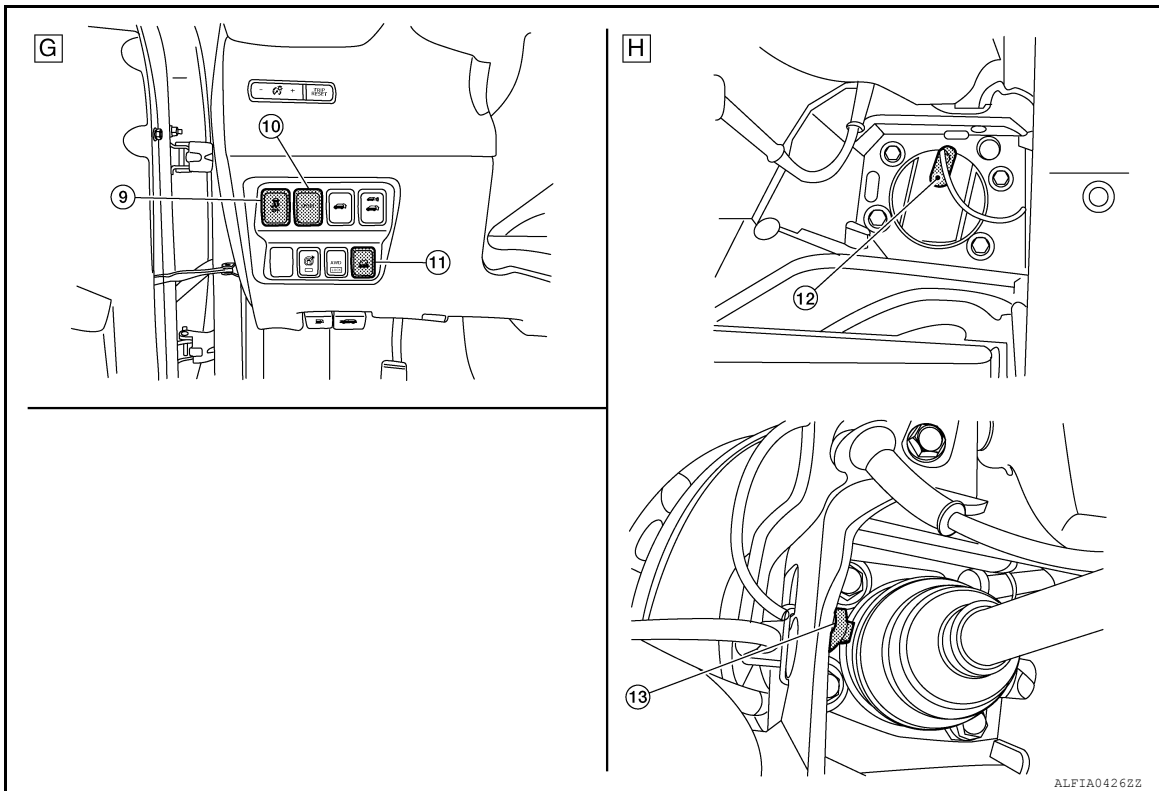

- |   |   |                                  |
|---|---|----------------------------------|
| A. Steering column (view with steering wheel removed) | B. RH side of instrument panel (view with instrument panel removed) | C. LH side of engine compartment |
| D. RH side of engine compartment                      | E. Left front wheel area  | F. Brake pedal area              |
| G. Left side of instrument panel                      | H. Left rear wheel area   |                                  |

No.	Component parts	Function
1.	Steering angle sensor	<a href="#">BRC-10, "Steering Angle Sensor"</a>
2.	Chassis control module	Mainly transmits the following signals to ABS actuator and electric unit (control unit) via CAN communication: <ul style="list-style-type: none"> <li>• Drive mode signal</li> <li>• Active Trace Control signal</li> <li>• Brake hold status signal</li> <li>• Brake hold request signal</li> </ul> Refer to <a href="#">DAS-183, "Component Parts Location"</a> for detailed installation location.
3.	Brake fluid level switch	<a href="#">BRC-10, "Brake Fluid Level Switch"</a>
4.	Vacuum sensor	<a href="#">BRC-11, "Vacuum Sensor"</a>
5.	ABS actuator and electric unit (control unit)	<a href="#">BRC-9, "ABS Actuator and Electric Unit (Control Unit)"</a>
6.	Front LH wheel sensor	<a href="#">BRC-9, "Wheel Sensor and Sensor Rotor"</a>
7.	Parking brake switch	<a href="#">BRC-11, "Parking Brake Switch"</a>
8.	Stop lamp switch	<a href="#">BRC-11, "Parking Brake Switch"</a>
9.	VDC OFF switch	<a href="#">BRC-11, "VDC OFF Switch"</a>
10.	Drive mode switch	<a href="#">DMS-6, "SPORT Mode Switch"</a>
11.	Hill descent switch	<a href="#">BRC-11, "Hill Descent Control Switch"</a>
12.	Rear wheel sensor LH (FWD models)	<a href="#">BRC-9, "Wheel Sensor and Sensor Rotor"</a>
13.	Rear wheel sensor LH (AWD models)	<a href="#">BRC-9, "Wheel Sensor and Sensor Rotor"</a>



# COMPONENT PARTS

< SYSTEM DESCRIPTION >

[VDC/TCS/ABS]

## Wheel Sensor and Sensor Rotor

INFOID:000000011280560

### NOTE:

- Wheel sensor of front wheel is installed on steering knuckle.
- Sensor rotor of front wheel is integrated in wheel hub assembly.
- Wheel sensor of rear wheel is installed on rear final drive.
- Sensor rotor of rear wheel is installed on drive shaft (rear final drive side).
- Never measure resistance and voltage value using a tester because sensor is active sensor.

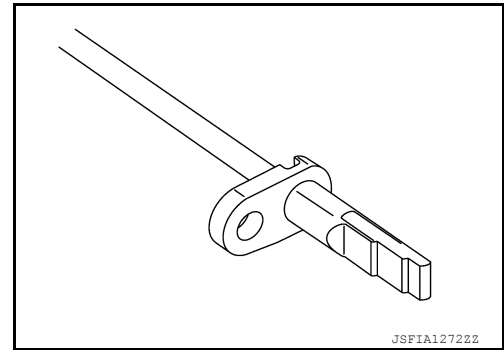

- Power supply is supplied to detection portion so that magnetic field line is read. Magnetic field that is detected is converted to current signal.
- When sensor rotor rotates, magnetic field changes. Magnetic field change is converted to current signals (rectangular wave) and is transmitted to ABS actuator and electric unit (control unit). Change of magnetic field is proportional to wheel speed.

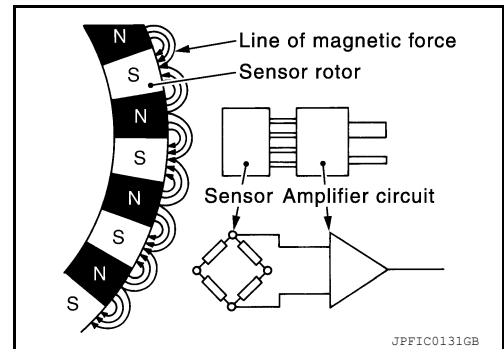

## ABS Actuator and Electric Unit (Control Unit)

INFOID:000000011280561

Electric unit (control unit) is integrated with actuator and comprehensively controls VDC function, TCS function, ABS function, EBD function, Brake limited slip differential (BLSD) function, Brake assist function, hill start assist function and Brake force distribution function.

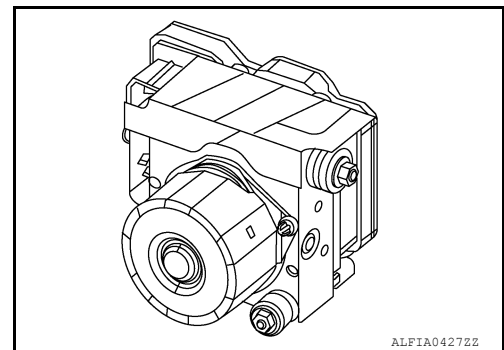

### ELECTRIC UNIT (CONTROL UNIT)

- Brake fluid pressure, engine and transmission are controlled according to signals from each sensor.
- If malfunction is detected, the system enters fail-safe mode.

### ACTUATOR

The following components are integrated with ABS actuator.

#### Pump

Returns the brake fluid reserved in reservoir to master cylinder by reducing pressure.

#### Motor

Activates the pump according to signals from ABS actuator and electric unit (control unit).

#### Motor Relay

Operates the motor ON/OFF according to signals from ABS actuator and electric unit (control unit).

#### Actuator Relay

Operates each valve ON/OFF according to signals from ABS actuator and electric unit (control unit).

#### ABS IN Valve and ABS OUT Valve

Increases, holds or decreases the fluid pressure of each caliper according to signals from ABS actuator and electric unit (control unit).

A  
B  
C  
D  
E  
BRC  
G  
H  
I  
J  
K  
L  
M  
N  
O  
P

# COMPONENT PARTS

[VDC/TCS/ABS]

## < SYSTEM DESCRIPTION >

### Pressure Sensor

Detects the brake fluid pressure and transmits signal to ABS actuator and electric unit (control unit).

### Cut Valve 1 (Primary Line), Cut Valve 2 (Secondary Line)

Shuts off the ordinary brake line from master cylinder, when VDC function, TCS function, Brake limited slip differential (BLSD) function, Brake assist function, hill start assist function and Brake force distribution function are activated.

### Yaw Rate/Side/Decel G Sensor

Calculates the following information that affects the vehicle, and transmits a signal to ABS actuator and electric unit (control unit). [Yaw rate/side/decels G sensor is integrated in ABS actuator and electric unit (control unit).]

- Vehicle rotation angular velocity (yaw rate signal)
- Vehicle lateral acceleration (side G signal)
- Vehicle longitudinal acceleration (decel G signal)

### Stop Lamp Switch

INFOID:000000011280562

Detects the operation status of brake pedal and transmits converted electric signal to ABS actuator and electric unit (control unit).

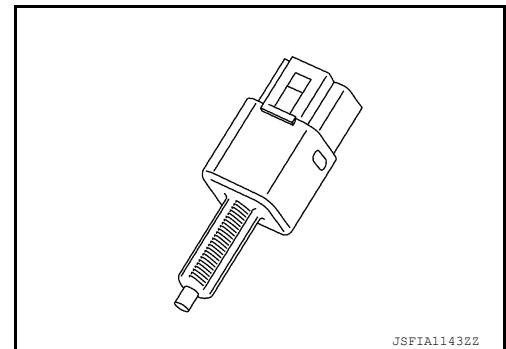

### Steering Angle Sensor

INFOID:000000011280563

Detects the following information and transmits steering angle signal to ABS actuator and electric unit (control unit) via CAN communication:

- Steering angle sensor malfunction signal
- Steering wheel rotation amount
- Steering wheel rotation angular velocity
- Steering wheel rotation direction

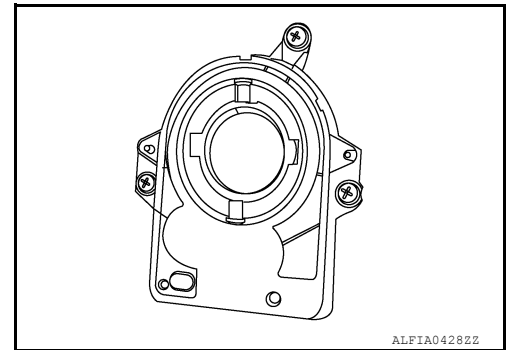

### Brake Fluid Level Switch

INFOID:000000011280564

Detects the brake fluid level in reservoir tank and transmits converted electric signal from combination meter to ABS actuator and electric unit (control unit) via CAN communication, when brake fluid level is the specified level or less.

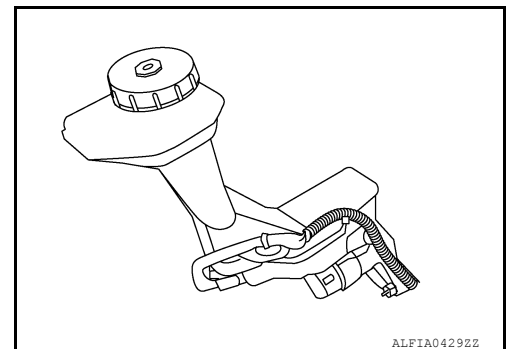

# COMPONENT PARTS

< SYSTEM DESCRIPTION >

[VDC/TCS/ABS]

## Vacuum Sensor

INFOID:000000011280565

Detects the vacuum in brake booster and transmits converted electric signal to ABS actuator and electric unit (control unit).

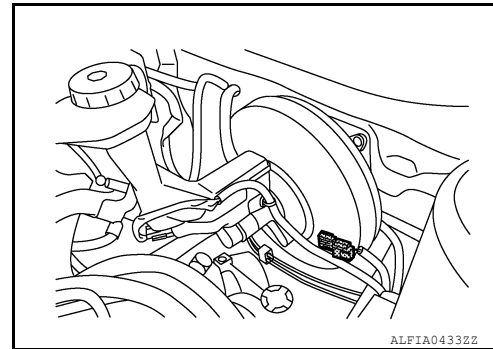

## Parking Brake Switch

INFOID:000000011280566

Detects the operation status of parking brake switch and transmits converted electric signal from combination meter to ABS actuator and electric unit (control unit).

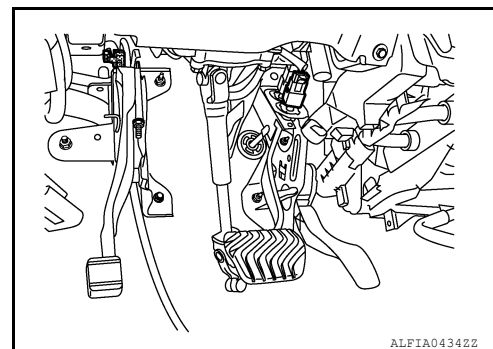

## VDC OFF Switch

INFOID:000000011280567

- This is an integrated switch with switches for other functions.
- Non-operational status or standby status of the following functions can be selected using VDC OFF switch. VDC OFF indicator lamp indicates the operation status of function. (ON: Non-operational status, OFF: Standby status):
  - VDC function
  - TCS function
  - Active trace control function

### NOTE:

ABS function, EBD function and Brake limited slip differential (BLSD) function control operates.

- VDC OFF indicator lamp turns OFF (standby status) when the engine is started again after it is stopped once while VDC OFF indicator lamp is ON (non-operational status).

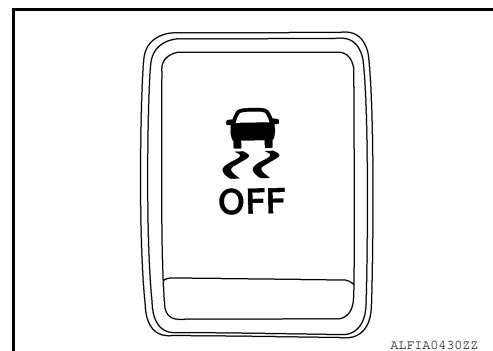

## Hill Descent Control Switch

INFOID:000000011280568

- The hill descent control system will help maintain vehicle speed on steeper downhill grades. Hill descent control will provide braking allowing the driver to concentrate on steering while reducing the burden and accelerator operation.

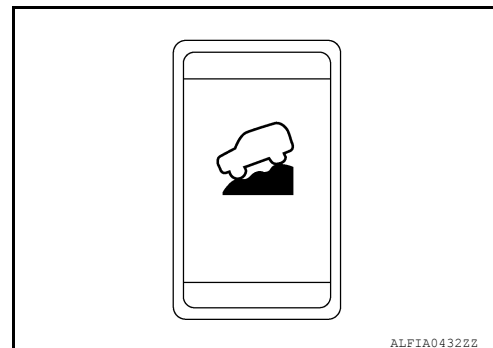

A  
B  
C  
D  
E  
BRC  
G  
H  
I  
J  
K  
L  
M  
N  
O  
P

SYSTEM

System Description

INFOID:000000011280569

- The system switches fluid pressure of each brake caliper to increase, to hold or to decrease according to signals from control unit in ABS actuator and electric unit (control unit). This control system is applied to VDC function, TCS function, ABS function, EBD function, brake limited slip differential (BLSD) function, brake assist function, hill start assist function and Brake force distribution function.
- Fail-safe function is available for each function and is activated by each function when system malfunction occurs.

SYSTEM DIAGRAM

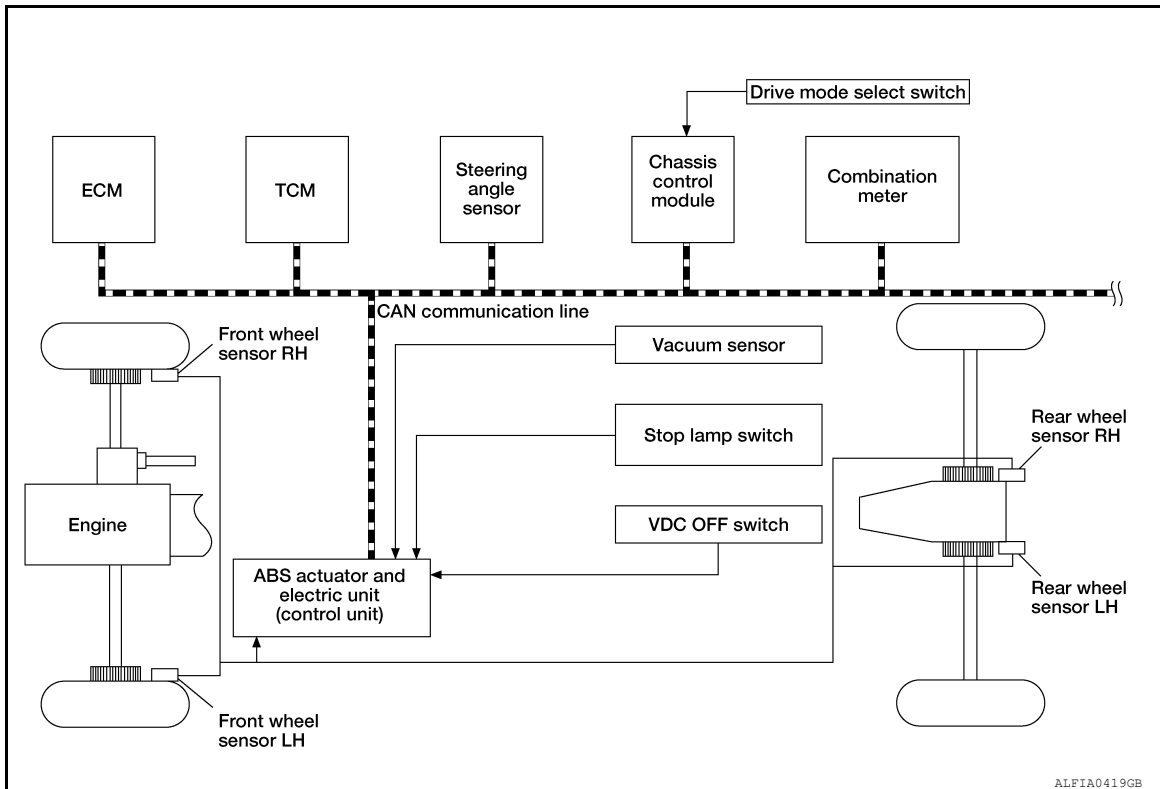

INPUT SIGNAL AND OUTPUT SIGNAL

Major signal transmission between each unit via communication lines is shown in the following table.

Component	Signal description
ECM	<p>Mainly transmits the following signals to ABS actuator and electric unit (control unit) via CAN communication:</p> <ul style="list-style-type: none"> <li>• Accelerator pedal position signal</li> <li>• Engine speed signal</li> <li>• Engine torque signal</li> </ul> <p>Mainly receives the following signal from ABS actuator and electric unit (control unit) via CAN communication:</p> <ul style="list-style-type: none"> <li>• Engine torque request signal</li> </ul>
TCM	<p>Mainly transmits the following signal to ABS actuator and electric unit (control unit) via CAN communication:</p> <ul style="list-style-type: none"> <li>• Current gear position signal</li> </ul>
Chassis control module	<p>Mainly transmits the following signal to ABS actuator and electric unit (control unit) via CAN communication:</p> <ul style="list-style-type: none"> <li>• Active trace control signal</li> </ul>

# SYSTEM

< SYSTEM DESCRIPTION >

[VDC/TCS/ABS]

Component	Signal description
Combination meter	Mainly receives the following signals from ABS actuator and electric unit (control unit) via CAN communication: <ul style="list-style-type: none"> <li>• Brake fluid level switch signal</li> <li>• Parking brake switch signal</li> </ul>
	Mainly receives the following signals from ABS actuator and electric unit (control unit) via CAN communication: <ul style="list-style-type: none"> <li>• Brake warning lamp signal</li> <li>• ABS warning lamp signal</li> <li>• VDC warning lamp signal</li> <li>• VDC OFF indicator lamp signal</li> </ul>
Steering angle sensor	Mainly transmits the following signals to ABS actuator and electric unit (control unit) via CAN communication: <ul style="list-style-type: none"> <li>• Steering angle sensor signal</li> <li>• Steering angle sensor malfunction signal</li> </ul>

## VALVE OPERATION (ABS AND EBD)

Each valve is operated and fluid pressure of brake caliper is controlled.

When ordinary brake is applied and ABS is in operation (when pressure increases).

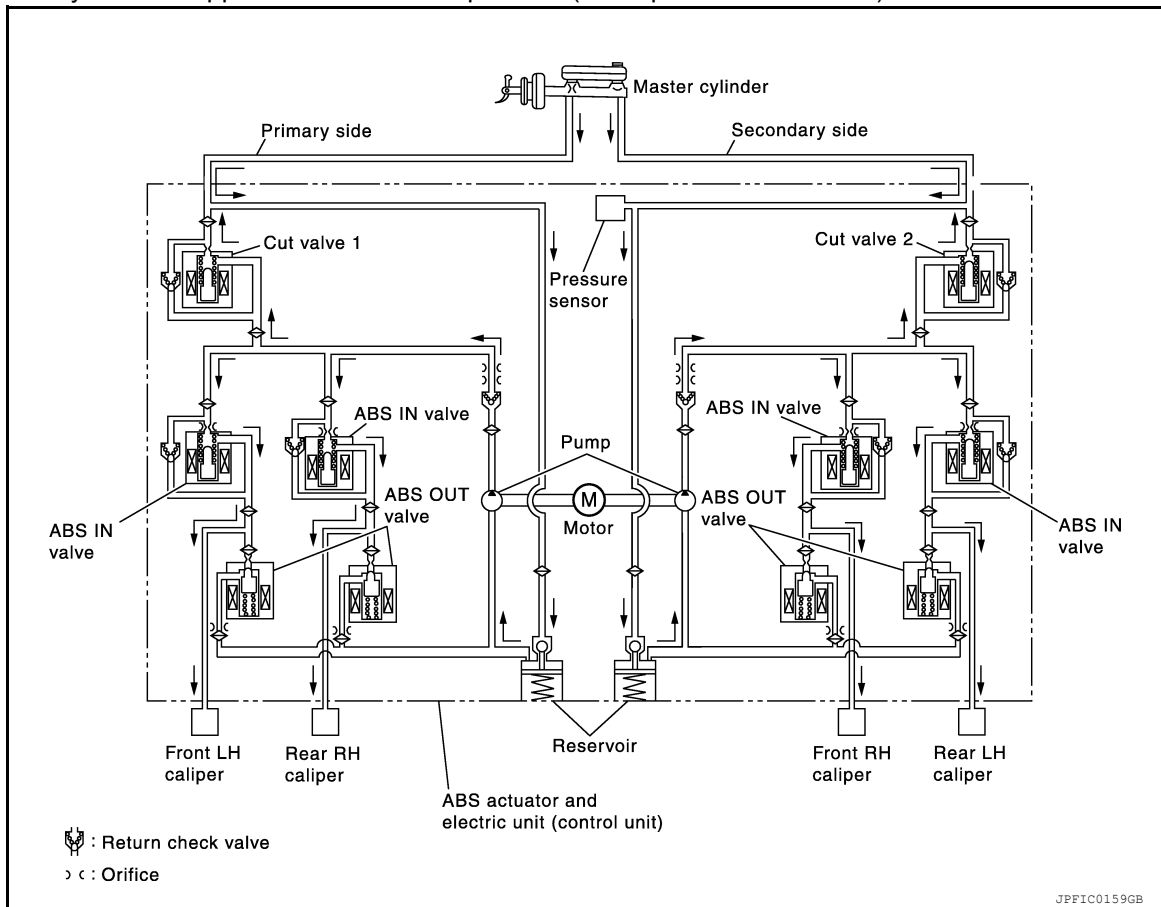

Name	Not activated	When Pressure Increases
Cut valve 1	Power supply is not supplied (open)	Power supply is not supplied (open)
Cut valve 2	Power supply is not supplied (open)	Power supply is not supplied (open)
ABS IN valve	Power supply is not supplied (open)	Power supply is not supplied (open)
ABS OUT valve	Power supply is not supplied (close)	Power supply is not supplied (close)
Each caliper (fluid pressure)	—	Pressure increases

When front RH wheel caliper pressure increases

# SYSTEM

[VDC/TCS/ABS]

## < SYSTEM DESCRIPTION >

- Motor is activated. Brake fluid is pressurized by pump and is sent to secondary line through cut valve 2. At the same time, pressurized brake fluid is supplied to front RH caliper through ABS IN valve.

When front LH wheel caliper pressure increases

- Motor is activated. Brake fluid is pressurized by pump and is sent to primary line through cut valve 1. At the same time, pressurized brake fluid is supplied to front LH wheel caliper through ABS IN valve.

When rear RH wheel caliper pressure increases

- Motor is activated. Brake fluid is pressurized by pump and is sent to primary line through cut valve 1. At the same time, pressurized brake fluid is supplied to rear RH wheel caliper through ABS IN valve.

When rear LH wheel caliper pressure increases

- Motor is activated. Brake fluid is pressurized by pump and is sent to secondary line through cut valve 2. At the same time, pressurized brake fluid is supplied to rear LH wheel caliper through ABS IN valve.

When ABS operation starts (when pressure holds)

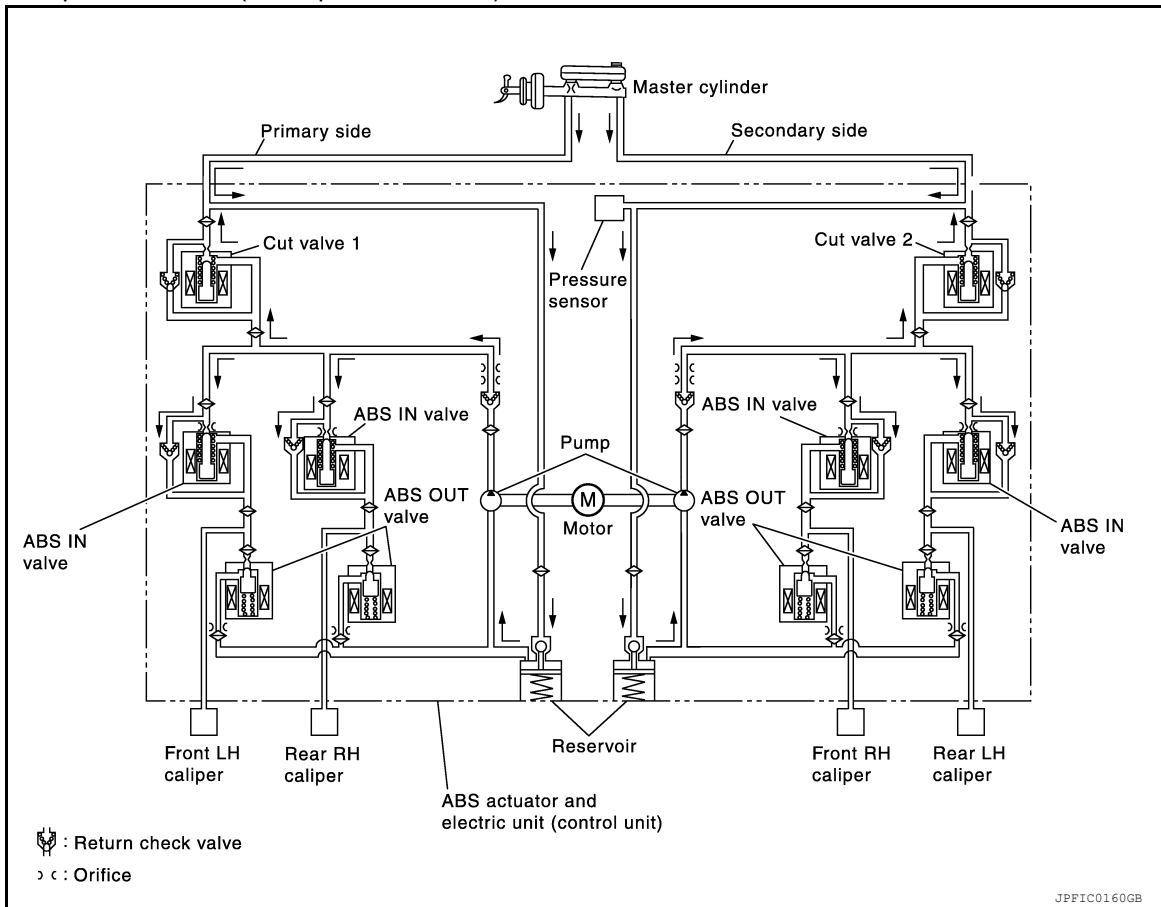

Name	Not activated	When pressure holds
Cut valve 1	Power supply is not supplied (open)	Power supply is not supplied (open)
Cut valve 2	Power supply is not supplied (open)	Power supply is not supplied (open)
ABS IN valve	Power supply is not supplied (open)	Power supply is supplied (close)
ABS OUT valve	Power supply is not supplied (close)	Power supply is not supplied (close)
Each caliper (fluid pressure)	—	Pressure holds

When front RH wheel caliper pressure holds

- Motor is activated. Brake fluid is pressurized by pump and is sent to secondary line through cut valve 2. At the same time, because ABS IN valve and ABS OUT valve are closed, fluid pressure holds.

When front LH wheel caliper pressure holds

- Motor is activated. Brake fluid is pressurized by pump and is sent to primary line through cut valve 1. At the same time, because ABS IN valve and ABS OUT valve are closed, fluid pressure holds.

# SYSTEM

[VDC/TCS/ABS]

## < SYSTEM DESCRIPTION >

When rear RH wheel caliper pressure holds

- Motor is activated. Brake fluid is pressurized by pump and is sent to primary line through cut valve 1. At the same time, because ABS IN valve and ABS OUT valve are closed, fluid pressure holds.

When rear LH wheel caliper pressure holds

- Motor is activated. Brake fluid is pressurized by pump and is sent to secondary line through cut valve 2. At the same time, because ABS IN valve and ABS OUT valve are closed, fluid pressure holds.

ABS is in operation (when pressure decreases)

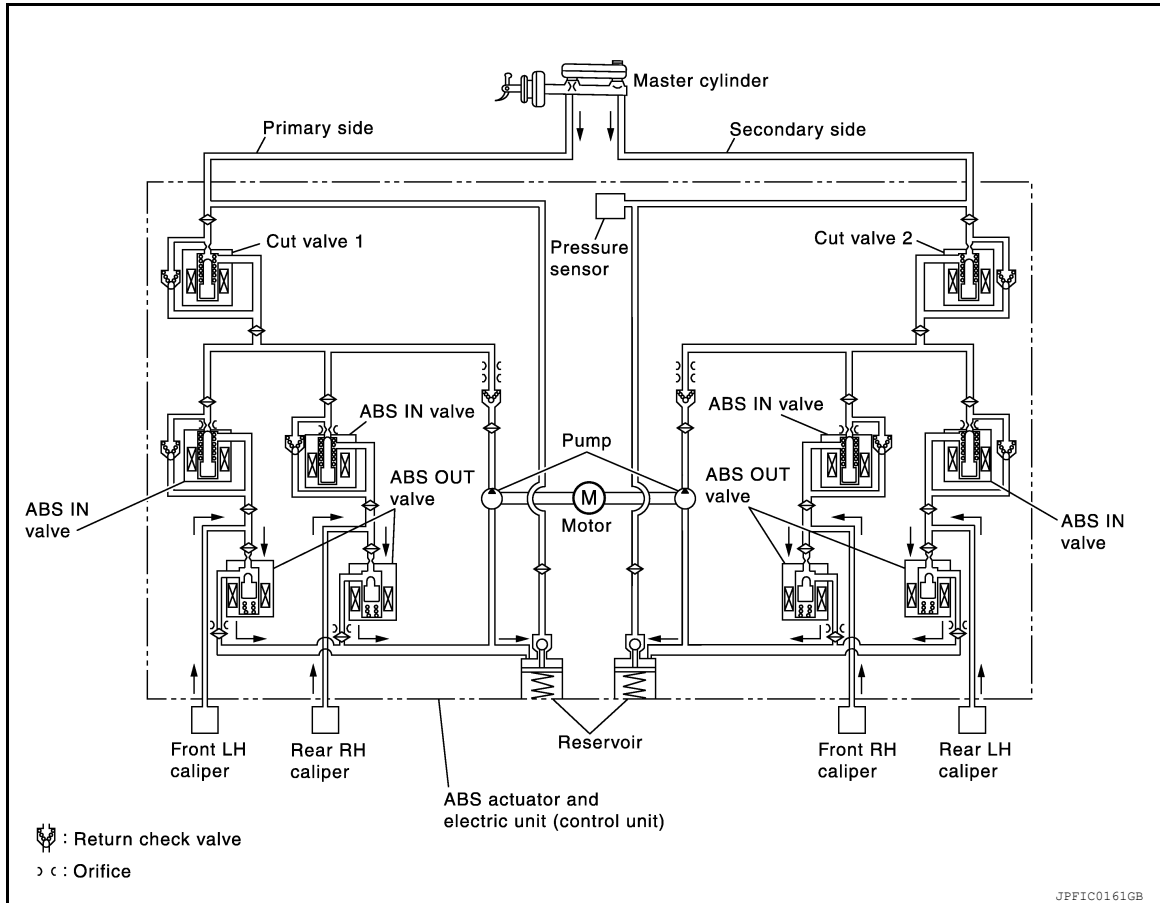

Name	Not activated	When pressure decreases
Cut valve 1	Power supply is not supplied (open)	Power supply is not supplied (open)
Cut valve 2	Power supply is not supplied (open)	Power supply is not supplied (open)
ABS IN valve	Power supply is not supplied (open)	Power supply is supplied (close)
ABS OUT valve	Power supply is not supplied (close)	Power supply is supplied (open)
Each caliper (fluid pressure)	—	Pressure decreases

When front RH wheel caliper pressure decreases

- Being supplied to reservoir through ABS OUT valve, the fluid pressure of brake caliper is decreased.

When front LH wheel caliper pressure decreases

- Being supplied to reservoir through ABS OUT valve, the fluid pressure of brake caliper is decreased.

When rear RH wheel caliper pressure decreases

- Being supplied to reservoir through ABS OUT valve, the fluid pressure of brake caliper is decreased.

When rear LH wheel caliper pressure decreases

- Being supplied to reservoir through ABS OUT valve, the fluid pressure of brake caliper is decreased.

Component Parts and Function

# SYSTEM

< SYSTEM DESCRIPTION >

[VDC/TCS/ABS]

Component	FUNCTION
Reservoir	Temporarily reserves the brake fluid drained from brake caliper, so that pressure efficiently decreases when decreasing pressure of brake caliper.
Pump	Returns the brake fluid reserved in reservoir to master cylinder by reducing pressure.
Motor	Drives the pump according to signals from control unit.
ABS IN valve	Switches the fluid pressure line to increase or hold according to signals from control unit.
ABS OUT valve	Switches the fluid pressure line to increase, hold or decrease according to signals from control unit.
Return check valve	Returns the brake fluid from brake caliper to master cylinder by bypassing orifice of each valve when brake is released.
Cut valve 1 Cut valve 2	Performs the duty control of fluid pressure increased by pump according to signals from control unit.
Pressure Sensor	Detects the brake pedal operation amount.

## VALVE OPERATION (OTHER THAN ABS AND EBD)

Each valve is operated and fluid pressure of brake caliper is controlled.

### NOTE:

There is no operation to hold and increase pressure for functions other than ABS and EBD.

When Pressure Increases

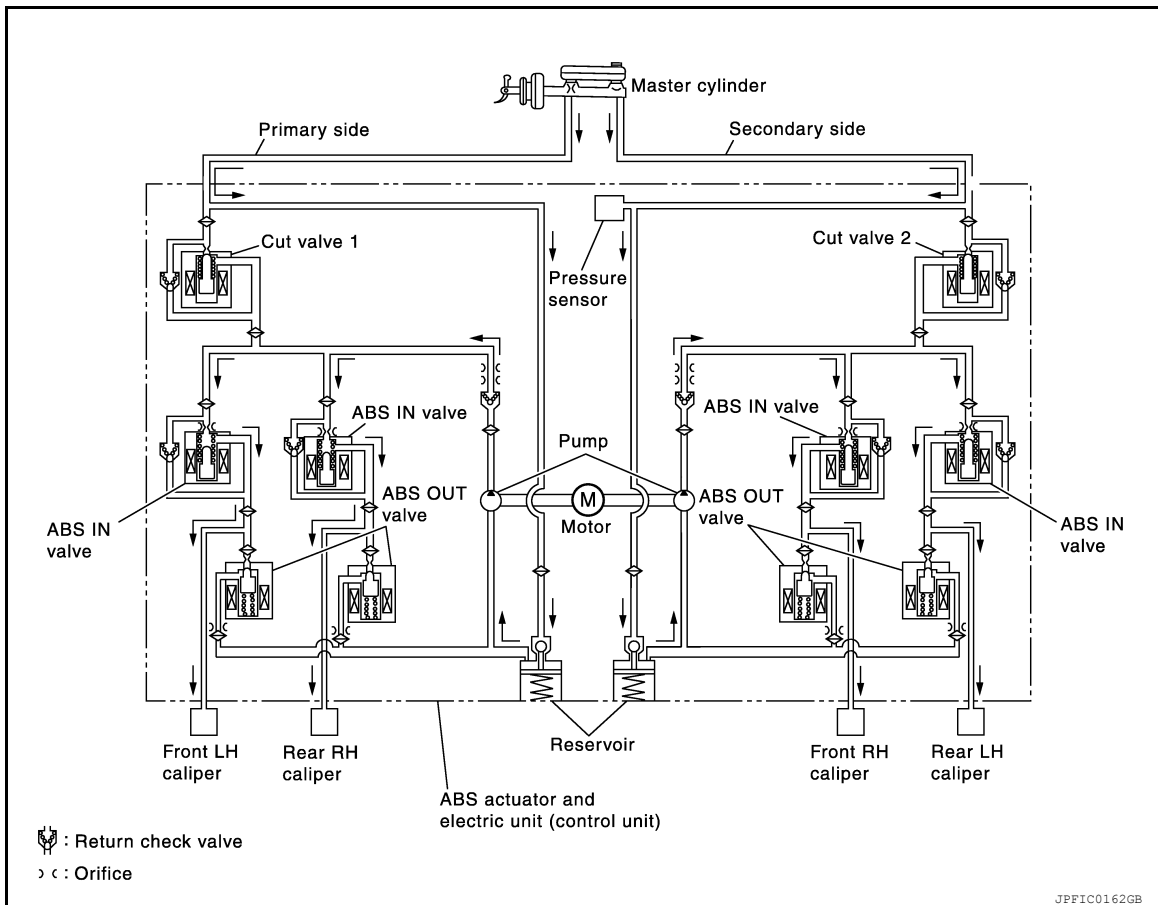



# SYSTEM

< SYSTEM DESCRIPTION >

[VDC/TCS/ABS]

Name	Not activated	When Pressure Increases
Cut valve 1	Power supply is not supplied (open)	Wheel other than the one that the pressure is to be increased: Power supply is not supplied (open) Only wheel that the pressure is to be increased: Power supply is supplied (close)
Cut valve 2	Power supply is not supplied (open)	Wheel other than the one that the pressure is to be increased: Power supply is not supplied (open) Only wheel that the pressure is to be increased: Power supply is supplied (close)
ABS IN valve	Power supply is not supplied (open)	Only wheel that the pressure is to be increased: Power supply is not supplied (open) Wheel other than the one that the pressure is to be increased: Power supply is supplied (close)
ABS OUT valve	Power supply is not supplied (close)	Power supply is not supplied (close)
Each caliper (fluid pressure)	—	Pressure increases

A  
B  
C  
D  
E  
**BRC**

When front RH wheel caliper pressure increases

- Motor is activated. Brake fluid from pump is supplied to front RH wheel caliper through ABS IN valve. For other wheel, ABS IN valve is closed and brakes fluid is not supplied to caliper.

When front LH wheel caliper pressure increases

- Motor is activated. Brake fluid from pump is supplied to front LH wheel caliper through ABS IN valve. For other wheel, ABS IN valve is closed and brakes fluid is not supplied to caliper.

When rear RH wheel caliper pressure increases

- Motor is activated. Brake fluid from pump is supplied to rear RH wheel caliper through ABS IN valve. For other wheel, ABS IN valve is closed and brakes fluid is not supplied to caliper.

When rear LH wheel caliper pressure increases

- Motor is activated. Brake fluid from pump is supplied to rear LH wheel caliper through ABS IN valve. For other wheel, ABS IN valve is closed and brakes fluid is not supplied to caliper.

G  
H  
I  
J  
K  
L  
M  
N  
O  
P

# SYSTEM

< SYSTEM DESCRIPTION >

[VDC/TCS/ABS]

Released

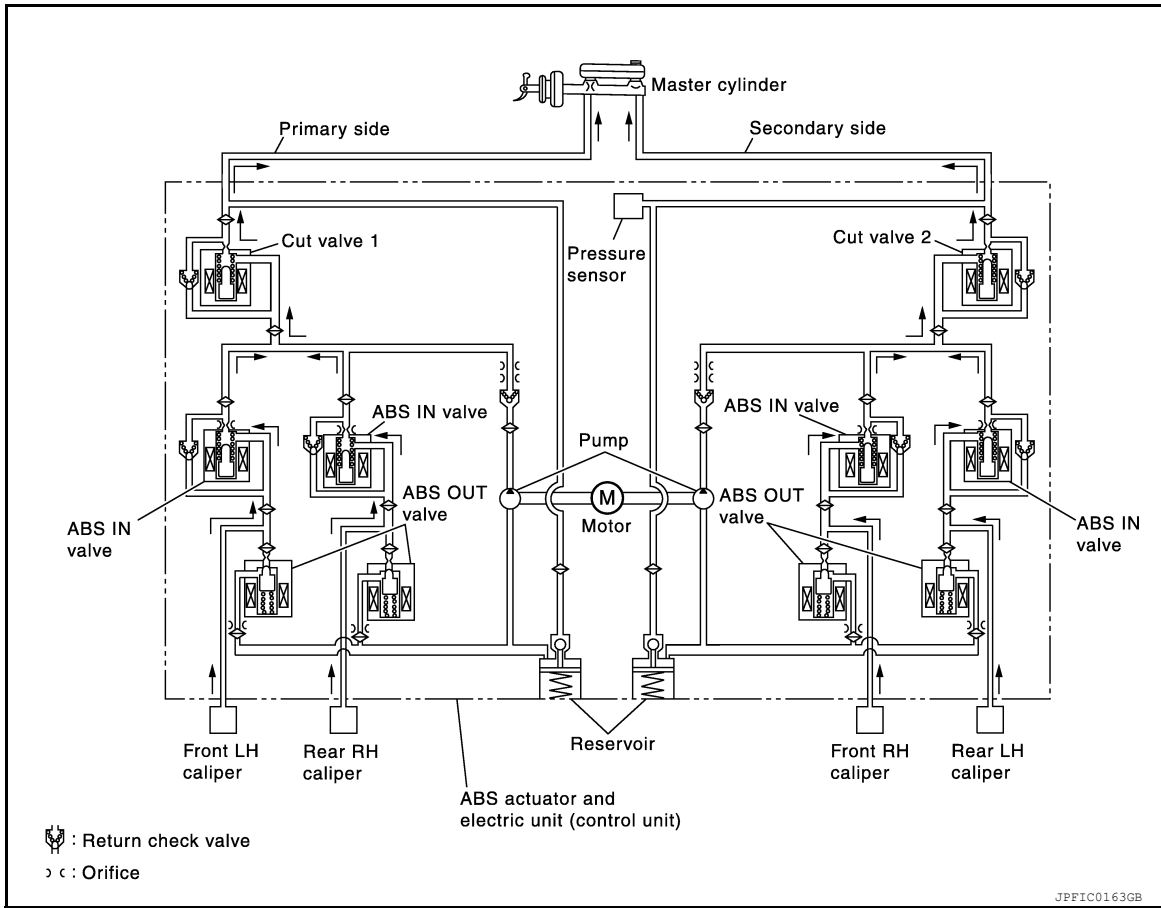

Name	Not activated	When pressure decreases
Cut valve 1	Power supply is not supplied (open)	Power supply is not supplied (open)
Cut valve 2	Power supply is not supplied (open)	Power supply is not supplied (open)
ABS IN valve	Power supply is not supplied (open)	Power supply is not supplied (open)
ABS OUT valve	Power supply is not supplied (close)	Power supply is supplied (open)
Each caliper (fluid pressure)	—	Pressure decreases

When front RH wheel caliper pressure decreases

- Being returned to master cylinder through ABS IN valve, fluid pressure of brake caliper is decreased.

When front LH wheel caliper pressure decreases

- Being returned to master cylinder through ABS IN valve, fluid pressure of brake caliper is decreased.

When rear RH wheel caliper pressure decreases

- Being returned to master cylinder through ABS IN valve, fluid pressure of brake caliper is decreased.

When rear LH wheel caliper pressure decreases

- Being returned to master cylinder through ABS IN valve, fluid pressure of brake caliper is decreased.

## Component Parts and Function

Component	Function
Reservoir	Temporarily reserves the brake fluid drained from brake caliper, so that pressure efficiently decreases when decreasing pressure of brake caliper.
Pump	Returns the brake fluid reserved in reservoir to master cylinder by reducing pressure.
Motor	Drives the pump according to signals from control unit.
ABS IN valve	Switches the fluid pressure line to increase or hold according to signals from control unit.

# SYSTEM

## < SYSTEM DESCRIPTION >

[VDC/TCS/ABS]

Component	Function
ABS OUT valve	Switches the fluid pressure line to increase, hold or decrease according to signals from control unit.
Return check valve	Returns the brake fluid from brake caliper to master cylinder by bypassing orifice of each valve when brake is released.
Cut valve 1 Cut valve 2	Performs the duty control of fluid pressure increased by pump according to signals from control unit.
Pressure Sensor	Detects the brake pedal operation amount.

### CONDITION FOR TURN ON THE WARNING LAMP

Turns ON when ignition switch turns ON and turns OFF when the system is normal, for bulb check purposes.

Condition (status)	ABS warning lamp	Brake warning lamp	VDC warning lamp
Ignition switch OFF.	OFF	OFF	OFF
For approx. 1 seconds after the ignition switch is turned ON	ON	ON	ON
Approx. 1 seconds after ignition switch is turned ON (when the system is in normal operation).	OFF	OFF	OFF
After engine starts	OFF	OFF	OFF
When brake fluid is less than the specified level (brake fluid level switch ON)	OFF	ON	OFF
When parking brake operates (parking brake switch ON)	OFF	ON	OFF
VDC function is malfunctioning	OFF	OFF	ON
TCS function is malfunctioning	OFF	OFF	ON
ABS function is malfunctioning	ON	OFF	ON
EBD function is malfunctioning	ON	ON	ON
Brake limited slip differential (BLSD) function is malfunctioning	OFF	OFF	ON
Brake assist function is malfunctioning	OFF	OFF	ON
hill start assist function is malfunctioning	OFF	OFF	ON
hill descent function is malfunctioning	ON	ON	OFF
Brake force distribution function is malfunctioning	OFF	OFF	ON
When brake booster vacuum decreases	OFF	ON	OFF
When vacuum sensor is malfunctioning	OFF	ON	OFF
VDC function is operating	OFF	OFF	Blinking
TCS function is operating	OFF	OFF	Blinking
ABS function is operating	OFF	OFF	OFF
EBD function is operating	OFF	OFF	OFF
Brake limited slip differential (BLSD) function is operating	OFF	OFF	Blinking
Brake assist function is operating	OFF	OFF	OFF
hill start assist function is operating	OFF	OFF	OFF
hill descent function is operating	OFF	OFF	OFF

### CONDITION FOR TURN ON THE INDICATOR LAMP

VDC OFF indicator lamp

- Turns ON when VDC function and TCS function are switched to non-operational status (OFF) by VDC OFF switch.
- Turns ON when ignition switch turns ON and turns OFF when the system is normal, for bulb check purposes.

Condition (status)	VDC OFF indicator lamp
Ignition switch OFF.	OFF
For approx. 1 seconds after the ignition switch is turned ON.	ON

# SYSTEM

< SYSTEM DESCRIPTION >

[VDC/TCS/ABS]

Condition (status)	VDC OFF indicator lamp
Approx. 1 seconds after ignition switch is turned ON (when the system is in normal operation).	OFF
When VDC OFF switch is ON (VDC function, TCS function and Active trace control function are OFF).	ON

## CONDITION FOR TURN ON THE INDICATOR LAMP

Hill descent indicator lamp

- Turns ON by the hill descent switch.
- Turns ON when ignition switch turns ON and turns OFF when the system is normal, for bulb check purposes.

Condition (status)	Hill Descent indicator lamp
Ignition switch OFF.	OFF
For approx. 1 seconds after the ignition switch is turned ON.	ON
Approx. 1 seconds after ignition switch is turned ON (when the system is in normal operation).	OFF
When hill descent switch is ON.	ON
When hill descent control switch is on, but the system is not engaged.	Blinking

## Fail-Safe

INFOID:000000011280570

## VDC FUNCTION, TCS FUNCTION, BRAKE LIMITED SLIP DIFFERENTIAL FUNCTION, BRAKE ASSIST FUNCTION, hill start assist FUNCTION, hill descent FUNCTION AND BRAKE FORCE DISTRIBUTION FUNCTION

VDC warning lamp in combination meter turn ON when a malfunction occurs in system [ABS actuator and electric unit (control unit)]. The control is suspended for VDC function, TCS function, Brake limited slip differential (BLSD) function, Brake assist function, hill start assist function and Brake force distribution function. The vehicle status becomes the same as models without VDC function, TCS function, Brake limited slip differential (BLSD) function, Brake assist function, hill start assist function and Brake force distribution function. However, ABS function and EBD function are operated normally.

## ABS FUNCTION

ABS warning lamp and VDC warning lamp in combination meter turn ON when a malfunction occurs in system [ABS actuator and electric unit (control unit)]. The control is suspended for VDC function, TCS function, ABS function, Brake limited slip differential (BLSD) function, Brake assist function, hill start assist function and Brake force distribution function. The vehicle status becomes the same as models without VDC function, TCS function, ABS function, Brake limited slip differential (BLSD) function, Brake assist function, hill start assist function and Brake force distribution function. However, EBD function is operated normally.

### NOTE:

ABS self-diagnosis sound may be heard the same as in the normal condition, because self-diagnosis is performed when ignition switch turns ON and when vehicle initially starts.

## EBD FUNCTION

ABS warning lamp, brake warning lamp and VDC warning lamp in combination meter turn ON when a malfunction occurs in system [ABS actuator and electric unit (control unit)]. The control is suspended for VDC function, TCS function, ABS function, EBD function, Brake limited slip differential (BLSD) function, Brake assist function, hill start assist function and Brake force distribution function. The vehicle status becomes the same as models without VDC function, TCS function, ABS function, EBD function, Brake limited slip differential (BLSD) function, Brake assist function, hill start assist function and Brake force distribution function.

# SYSTEM

< SYSTEM DESCRIPTION >

[VDC/TCS/ABS]

DTC	Fail-safe condition	
C1101	The following functions are suspended: • VDC function • TCS function • ABS function • EBD function (only when both 2 rear wheels are malfunctioning) • Brake limited slip differential (BLSD) function • Brake assist function • hill start assist function • hill descent function • Brake force distribution function • Active trace control function (control of chassis control module)	A
C1102		B
C1103		C
C1104		D
C1105		E
C1106		F
C1107		G
C1108		H
C1109		I
C1111	The following functions are suspended: • VDC function • TCS function • ABS function • EBD function • Brake limited slip differential (BLSD) function • Brake assist function • hill start assist function • hill descent function • Brake force distribution function • Active trace control function (control of chassis control module)	J
		K
		L
		M
		N
		O
		P
		Q
		R
C1113	The following functions are suspended: • VDC function • TCS function • ABS function • EBD function • Brake limited slip differential (BLSD) function • Brake assist function • hill start assist function • hill descent function • Brake force distribution function • Active trace control function (control of chassis control module)	S
		T
		U
		V
		W
		X
		Y
		Z
		AA
C1115	The following functions are suspended: • VDC function • TCS function • ABS function • Brake limited slip differential (BLSD) function • Brake assist function • hill start assist function • hill descent function • Brake force distribution function • Active trace control function (control of chassis control module)	AB
		AC
		AD
		AE
		AF
		AG
		AH
		AI
		AJ
C1120	The following functions are suspended: • VDC function • TCS function • ABS function • EBD function • Brake limited slip differential (BLSD) function • Brake assist function • hill start assist function • hill descent function • Brake force distribution function • Active trace control function (control of chassis control module)	AK
C1121		AL
C1122		AM
C1123		AN
C1124		AO
C1125		AP
C1126		AQ
C1127		AR
		AS

BRC

# SYSTEM

< SYSTEM DESCRIPTION >

[VDC/TCS/ABS]

DTC	Fail-safe condition
C1130	The following functions are suspended: <ul style="list-style-type: none"><li>• VDC function</li><li>• TCS function</li><li>• Brake limited slip differential (BLSD) function</li><li>• hill start assist function</li><li>• hill descent function</li><li>• Brake force distribution function</li><li>• Active trace control function (control of chassis control module)</li></ul>
C1138	The following functions are suspended: <ul style="list-style-type: none"><li>• VDC function</li><li>• TCS function</li><li>• ABS function</li><li>• EBD function</li><li>• Brake limited slip differential (BLSD) function</li><li>• Brake assist function</li><li>• hill start assist function</li><li>• Brake force distribution function</li><li>• Active trace control function (control of chassis control module)</li></ul>
C1140	The following functions are suspended: <ul style="list-style-type: none"><li>• VDC function</li><li>• TCS function</li><li>• Brake limited slip differential (BLSD) function</li><li>• Brake assist function</li><li>• hill start assist function</li><li>• hill descent function</li><li>• Brake force distribution function</li><li>• Active trace control function (control of chassis control module)</li></ul>
C1142	The following functions are suspended: <ul style="list-style-type: none"><li>• VDC function</li><li>• TCS function</li><li>• Brake limited slip differential (BLSD) function</li><li>• Brake assist function</li><li>• hill start assist function</li><li>• hill descent function</li><li>• Brake force distribution function</li><li>• Active trace control function (control of chassis control module)</li></ul>
C1143	The following functions are suspended: <ul style="list-style-type: none"><li>• VDC function</li><li>• TCS function</li><li>• Brake limited slip differential (BLSD) function</li><li>• hill start assist function</li><li>• hill descent function</li><li>• Brake force distribution function</li><li>• Active trace control function (control of chassis control module)</li></ul>
C1144	The following functions are suspended: <ul style="list-style-type: none"><li>• VDC function</li><li>• TCS function</li><li>• Brake limited slip differential (BLSD) function</li><li>• Brake assist function</li><li>• hill start assist function</li><li>• hill descent function</li><li>• Brake force distribution function</li><li>• Active trace control function (control of chassis control module)</li></ul>
C1145	The following functions are suspended: <ul style="list-style-type: none"><li>• VDC function</li><li>• TCS function</li><li>• ABS function</li><li>• Brake limited slip differential (BLSD) function</li><li>• Brake assist function</li><li>• hill start assist function</li><li>• hill descent function</li><li>• Brake force distribution function</li><li>• Active trace control function (control of chassis control module)</li></ul>
C1146	The following functions are suspended: <ul style="list-style-type: none"><li>• VDC function</li><li>• TCS function</li><li>• Brake limited slip differential (BLSD) function</li><li>• Brake assist function</li><li>• hill start assist function</li><li>• hill descent function</li><li>• Brake force distribution function</li><li>• Active trace control function (control of chassis control module)</li></ul>
C1155	The following functions are suspended: <ul style="list-style-type: none"><li>• VDC function</li><li>• TCS function</li><li>• Brake limited slip differential (BLSD) function</li><li>• Brake assist function</li><li>• hill start assist function</li><li>• hill descent function</li><li>• Brake force distribution function</li><li>• Active trace control function (control of chassis control module)</li></ul>

# SYSTEM

< SYSTEM DESCRIPTION >

[VDC/TCS/ABS]

DTC	Fail-safe condition	
C1160	The following functions are suspended:	A
	<ul style="list-style-type: none"> <li>• VDC function</li> <li>• TCS function</li> <li>• ABS function</li> <li>• Brake limited slip differential (BLSD) function</li> <li>• Brake assist function</li> <li>• hill start assist function</li> <li>• hill descent function</li> <li>• Brake force distribution function</li> <li>• Active trace control function (control of chassis control module)</li> </ul>	B
C1164	The following functions are suspended:	C
C1165	<ul style="list-style-type: none"> <li>• VDC function</li> <li>• TCS function</li> <li>• ABS function</li> <li>• EBD function</li> <li>• Brake limited slip differential (BLSD) function</li> <li>• Brake assist function</li> <li>• hill start assist function</li> <li>• hill descent function</li> <li>• Brake force distribution function</li> <li>• Active trace control function (control of chassis control module)</li> </ul>	D
		E
C1170	The following functions are suspended:	BRC
	<ul style="list-style-type: none"> <li>• VDC function</li> <li>• TCS function</li> <li>• ABS function</li> <li>• Brake limited slip differential (BLSD) function</li> <li>• Brake assist function</li> <li>• hill start assist function</li> <li>• hill descent function</li> <li>• Brake force distribution function</li> <li>• Active trace control function (control of chassis control module)</li> </ul>	G
C1197	Electrical vacuum assistance of brake booster is suspended.	H
C1198		I
C1199		J
C119A	—	K
U1000	Electrical vacuum assistance of brake booster is suspended.	L
	The following functions are suspended:	M
	<ul style="list-style-type: none"> <li>• VDC function</li> <li>• TCS function</li> <li>• Brake limited slip differential (BLSD) function</li> <li>• hill start assist function</li> <li>• hill descent function</li> <li>• Brake force distribution function</li> <li>• Active trace control function (control of chassis control module)</li> </ul>	N

## VDC FUNCTION

### VDC FUNCTION : System Description

INFOID:000000011280571

- Side slip or tail slip may occur while driving on a slippery road or intending an urgent evasive driving. VDC function detects side slip status using each sensor when side slip or tail slip is about to occur and improves vehicle stability by brake control and engine output control during driving.
- In addition to ABS function, EBD function and TCS function, target side slip amount is calculated according to steering operation amount from steering angle sensor and brake operation amount from brake pressure sensor. By comparing this information with vehicle side slip amount that is calculated from information from yaw rate/side/decel G sensor and wheel sensor, vehicle driving conditions (conditions of understeer or over-

# SYSTEM

## < SYSTEM DESCRIPTION >

[VDC/TCS/ABS]

steer) are judged and vehicle stability is improved by brake force control on all 4 wheels and engine output control.

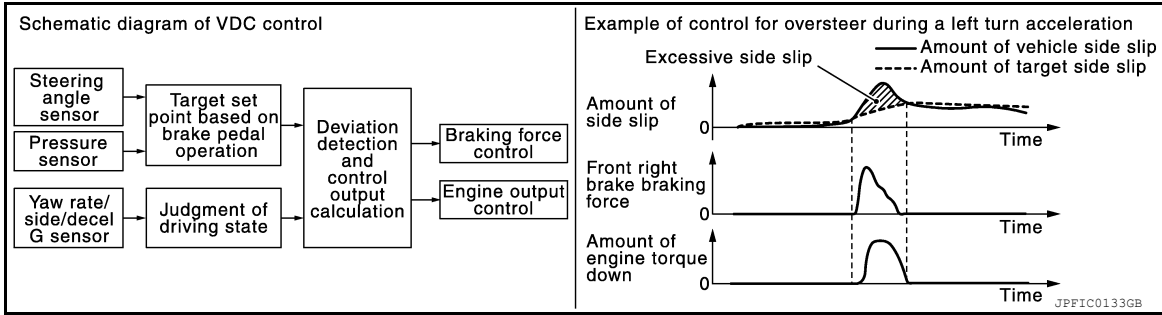

- VDC function can be switched to non-operational status (OFF) by operating VDC OFF switch. In this case, VDC OFF indicator lamp turns ON.
- Control unit portion automatically improves driving stability by performing brake force control as well as engine output control, by transmitting drive signal to actuator portion according to difference between target side slip amount and vehicle side slip amount
- VDC warning lamp blinks while VDC function is in operation and indicates to the driver that the function is in operation.
- CONSULT can be used to diagnose the system diagnosis.
- Fail-safe function is adopted. When a malfunction occurs in VDC function, the control is suspended for VDC function, TCS function, Brake limited slip differential (BLSD) function, Brake assist function, hill start assist function and Brake force distribution function. The vehicle status becomes the same as models without VDC function, TCS function, Brake limited slip differential (BLSD) function, Brake assist function, hill start assist function and Brake force distribution function. However, ABS function and EBD function are operated normally. Refer to [BRC-20, "Fail-Safe"](#).

## SYSTEM DIAGRAM

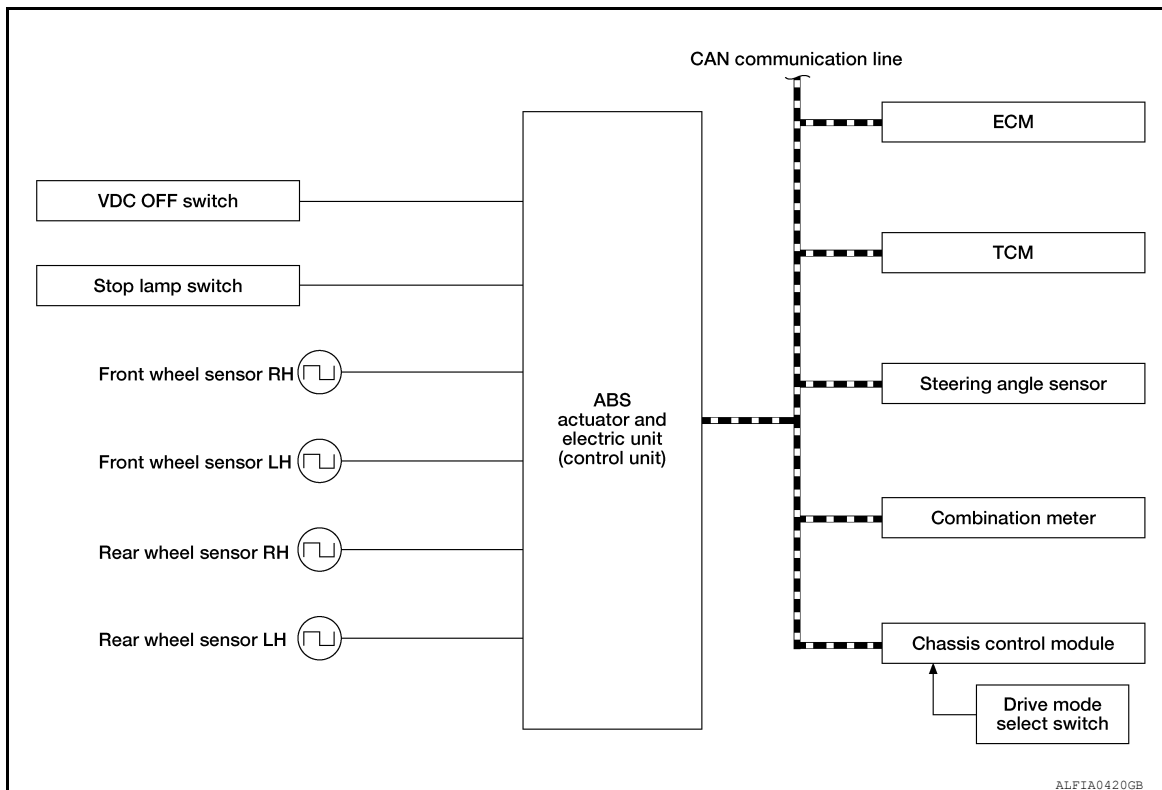

## INPUT SIGNAL AND OUTPUT SIGNAL

Major signal transmission between each unit via communication lines is shown in the following table.



# SYSTEM

< SYSTEM DESCRIPTION >

[VDC/TCS/ABS]

Component	Signal description
ECM	Mainly transmits the following signals to ABS actuator and electric unit (control unit) via CAN communication: <ul style="list-style-type: none"> <li>• Accelerator pedal position signal</li> <li>• Engine speed signal</li> <li>• Engine torque signal</li> </ul> Mainly receives the following signal from ABS actuator and electric unit (control unit) via CAN communication: <ul style="list-style-type: none"> <li>• Engine torque request signal</li> </ul>
TCM	Mainly transmits the following signal to ABS actuator and electric unit (control unit) via CAN communication: <ul style="list-style-type: none"> <li>• Current gear position signal</li> </ul>
Chassis control module	Mainly transmits the following signal to ABS actuator and electric unit (control unit) via CAN communication: <ul style="list-style-type: none"> <li>• Active trace control signal</li> </ul>
Combination meter	Mainly receives the following signals from ABS actuator and electric unit (control unit) via CAN communication: <ul style="list-style-type: none"> <li>• Brake fluid level switch signal</li> <li>• Parking brake switch signal</li> </ul> Mainly receives the following signals from ABS actuator and electric unit (control unit) via CAN communication: <ul style="list-style-type: none"> <li>• VDC warning lamp signal</li> <li>• VDC OFF indicator lamp signal</li> </ul>
Steering angle sensor	Mainly transmits the following signals to ABS actuator and electric unit (control unit) via CAN communication: <ul style="list-style-type: none"> <li>• Steering angle sensor signal</li> <li>• Steering angle sensor malfunction signal</li> </ul>

## OPERATION CHARACTERISTICS

### VDC Function That Prevents Oversteer Tendency

- During a cornering, brake force (brake fluid pressure) is applied on front wheel and rear wheel on the outer side of turn. Momentum directing towards the outer side of turn is generated. Oversteer is prevented.

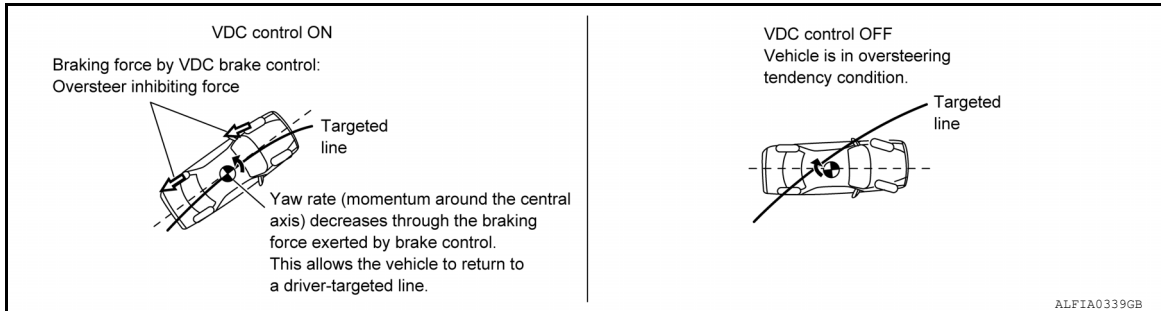

- Changing driving lane on a slippery road, when oversteer tendency is judged large, engine output is controlled as well as brake force (brake fluid pressure) of 4 wheels. Oversteer tendency decreases.

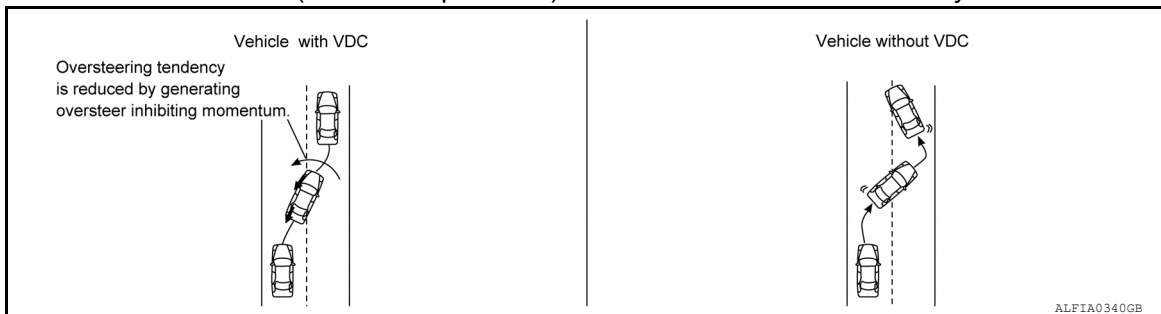

### VDC Function That Prevents Understeer Tendency

# SYSTEM

## < SYSTEM DESCRIPTION >

[VDC/TCS/ABS]

- During a cornering, brake force (brake fluid pressure) is applied on front wheel and rear wheel on the inner side of turn. Momentum directing towards the inner side of turn is generated. Understeer is prevented.

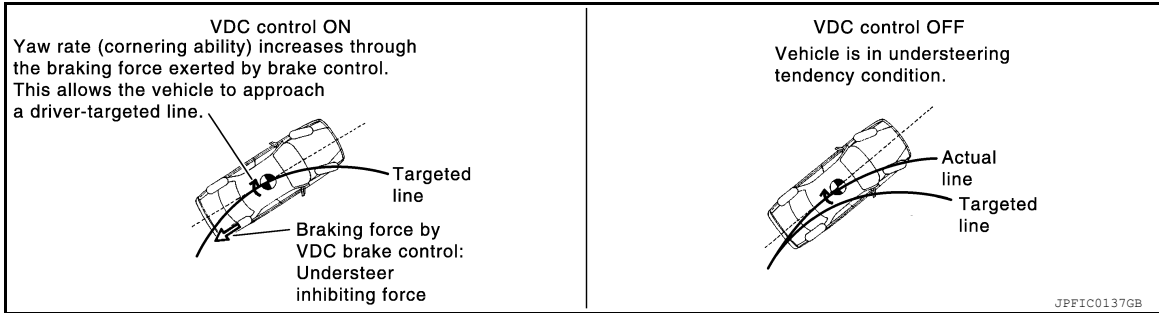

- Applying braking during a cornering on a slippery road, when understeer tendency is judged large, engine output is controlled as well as brake force (brake fluid pressure) of four wheels. Understeer tendency decreases.

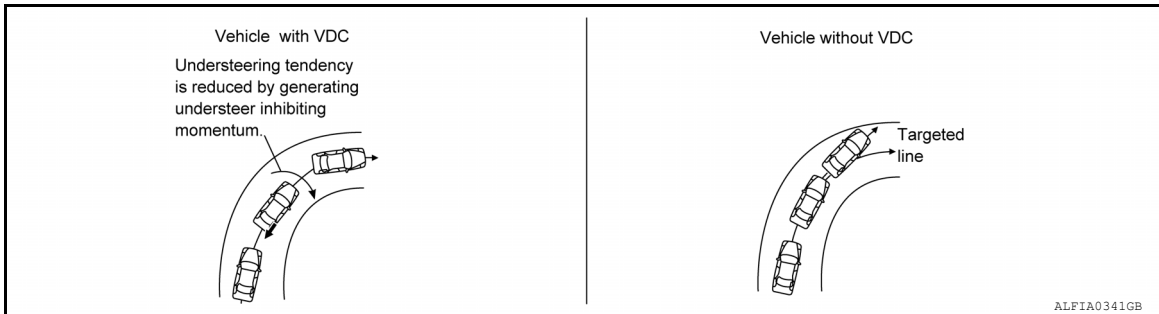

## TCS FUNCTION

### TCS FUNCTION : System Description

INFOID:000000011280572

- Wheel spin status of drive wheel is detected by wheel sensor of 4 wheels. Engine output and transmission shift status is controlled so that slip rate of drive wheels is in appropriate level. When wheel spin occurs on drive wheel, ABS actuator and electric unit (control unit) perform brake force control of LH and RH drive wheels (apply brake force by increasing brake fluid pressure of drive wheel) and decrease engine torque by engine torque control. Wheel spin amount decreases. Engine torque is controlled to appropriate level.
- TCS function can be switched to non-operational status (OFF) by operating VDC OFF switch. In this case, VDC OFF indicator lamp turns ON.
- VDC warning lamp blinks while TCS function is in operation and indicates to the driver that the function is in operation.
- CONSULT can be used to diagnose the system diagnosis.
- Fail-safe function is adopted. When a malfunction occurs in TCS function, the control is suspended for VDC function, TCS function, Brake limited slip differential (BLSD) function, Brake assist function, hill start assist function and Brake force distribution function. The vehicle status becomes the same as models without VDC function, TCS function, Brake limited slip differential (BLSD) function, Brake assist function, hill start assist function and Brake force distribution function. However, ABS function and EBD function are operated normally. Refer to [BRC-20. "Fail-Safe"](#).

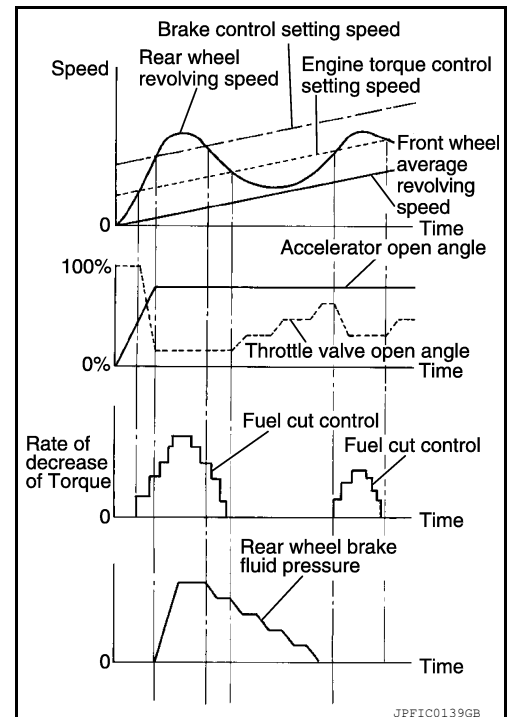

# SYSTEM

< SYSTEM DESCRIPTION >

[VDC/TCS/ABS]

## SYSTEM DIAGRAM

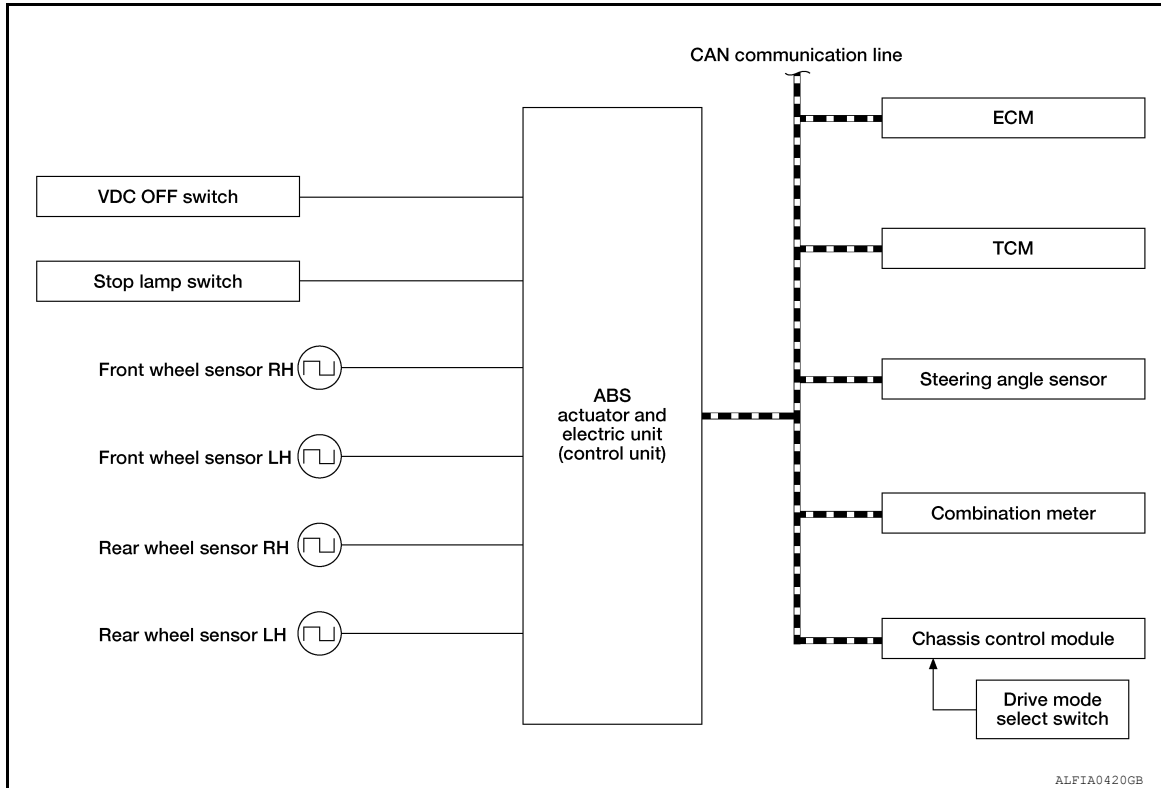

## INPUT SIGNAL AND OUTPUT SIGNAL

Major signal transmission between each unit via communication lines is shown in the following table.

Component	Signal description
ECM	<p>Mainly transmits the following signals to ABS actuator and electric unit (control unit) via CAN communication:</p> <ul style="list-style-type: none"> <li>• Accelerator pedal position signal</li> <li>• Engine speed signal</li> <li>• Engine torque signal</li> </ul> <p>Mainly receives the following signal from ABS actuator and electric unit (control unit) via CAN communication:</p> <ul style="list-style-type: none"> <li>• Engine torque request signal</li> </ul>
TCM	<p>Mainly transmits the following signal to ABS actuator and electric unit (control unit) via CAN communication:</p> <ul style="list-style-type: none"> <li>• Current gear position signal</li> </ul>
Chassis control module	<p>Mainly transmits the following signal to ABS actuator and electric unit (control unit) via CAN communication:</p> <ul style="list-style-type: none"> <li>• Active trace control signal</li> </ul>
Combination meter	<p>Mainly receives the following signals from ABS actuator and electric unit (control unit) via CAN communication:</p> <ul style="list-style-type: none"> <li>• Brake fluid level switch signal</li> <li>• Parking brake switch signal</li> </ul> <p>Mainly receives the following signals from ABS actuator and electric unit (control unit) via CAN communication:</p> <ul style="list-style-type: none"> <li>• VDC warning lamp signal</li> <li>• VDC OFF indicator lamp signal</li> </ul>
Steering angle sensor	<p>Mainly transmits the following signals to ABS actuator and electric unit (control unit) via CAN communication:</p> <ul style="list-style-type: none"> <li>• Steering angle sensor signal</li> <li>• Steering angle sensor malfunction signal</li> </ul>

## ABS FUNCTION

## ABS FUNCTION : System Description

INFOID:000000011280573

- By preventing wheel lock through brake force (brake fluid pressure) control that is electronically controlled by detecting wheel speed during braking, stability during emergency braking is improved so that obstacles can be easily bypassed by steering operation.
- During braking, control units calculates wheel speed and pseudo-vehicle speed, and transmits pressure increase, hold or decrease signals to actuator portion according to wheel slip status.
- The following effects are obtained by preventing wheel lock during braking:
  - Vehicle tail slip is prevented during braking when driving straight.
  - Understeer and oversteer tendencies are moderated during braking driving on a corner.
  - Obstacles may be easily bypassed by steering operation during braking.
- CONSULT can be used to diagnose the system diagnosis.
- Fail-safe function is adopted. When a malfunction occurs in ABS function, the control is suspended for VDC function, TCS function, ABS function, Brake limited slip differential (BLSD) function, Brake assist function, hill start assist function and Brake force distribution function. The vehicle status becomes the same as models without VDC function, TCS function, ABS function, Brake limited slip differential (BLSD) function, Brake assist function, hill start assist function and Brake force distribution function. However, EBD function is operated normally. Refer to [BRC-20. "Fail-Safe"](#).

**NOTE:**

- ABS has the characteristic as described here, This is not the device that helps reckless driving.
- To stop vehicle efficiently, ABS does not operate and ordinary brake operates at low speed [approx. 10 km/h (6 MPH) or less, but differs subject to road conditions).
- Self-diagnosis is performed immediately after when engine starts and when vehicle initially is driven [by vehicle speed approx. 15 km/h (9 MPH)]. Motor sounds are generated during self-diagnosis. In addition, brake pedal may be felt heavy when depressing brake pedal lightly. These symptoms are not malfunctions.

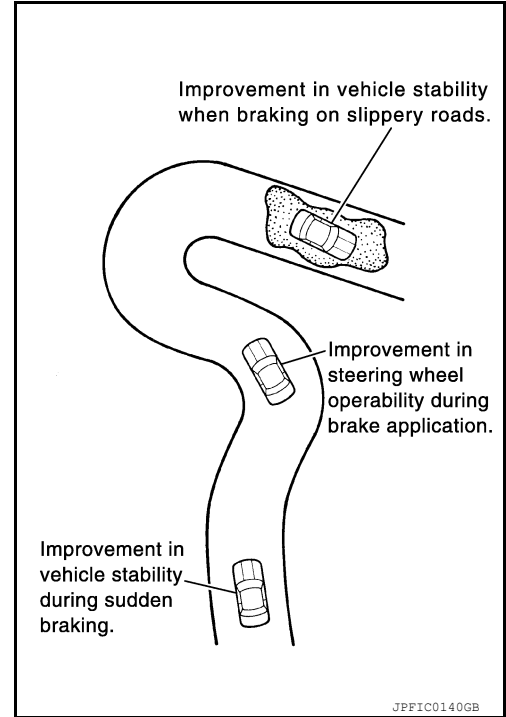

## SYSTEM DIAGRAM

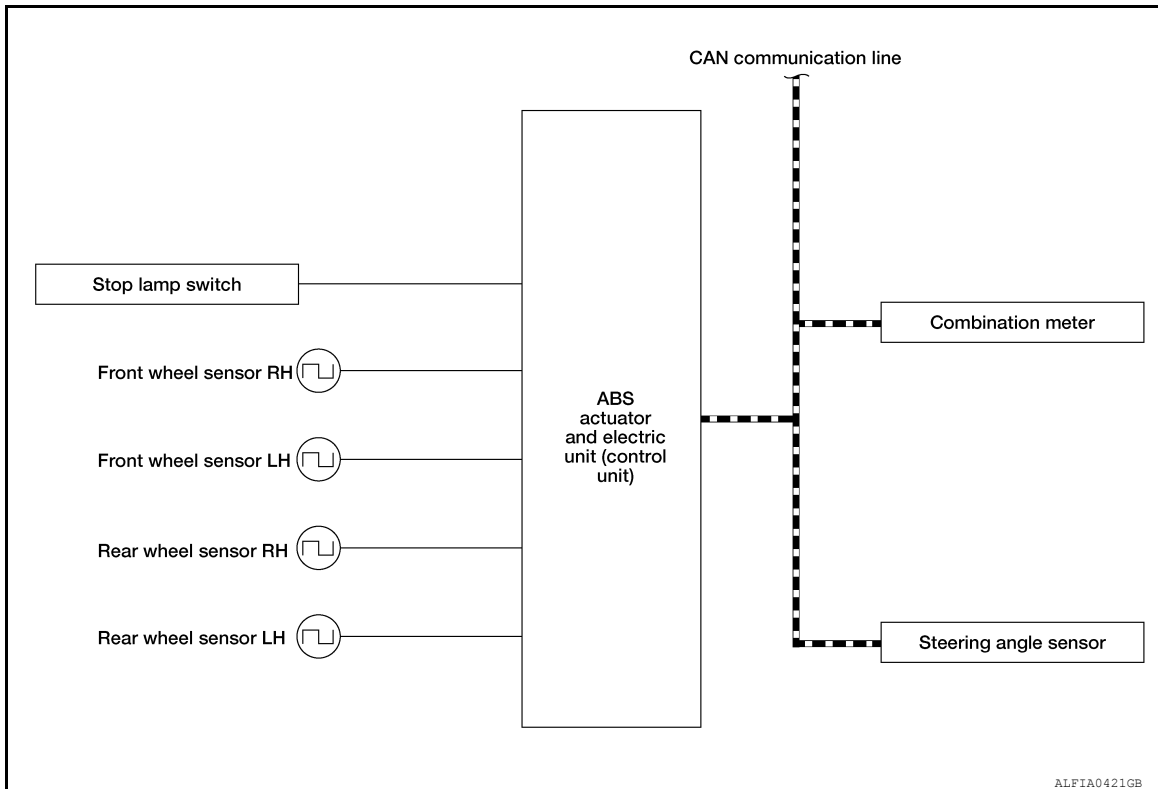

## INPUT SIGNAL AND OUTPUT SIGNAL

Major signal transmission between each unit via communication lines is shown in the following table.

Component	Signal description
Combination meter	Mainly receives the following signals from ABS actuator and electric unit (control unit) via CAN communication: <ul style="list-style-type: none"> <li>• Brake fluid level switch signal</li> <li>• Parking brake switch signal</li> </ul> Mainly receives the following signals from ABS actuator and electric unit (control unit) via CAN communication: <ul style="list-style-type: none"> <li>• ABS warning lamp signal</li> <li>• VDC warning lamp signal</li> <li>• VDC OFF indicator lamp signal</li> </ul>
Steering angle sensor	Mainly transmits the following signals to ABS actuator and electric unit (control unit) via CAN communication: <ul style="list-style-type: none"> <li>• Steering angle sensor signal</li> <li>• Steering angle sensor malfunction signal</li> </ul>

## EBD FUNCTION

### EBD FUNCTION : System Description

INFOID:0000000011280574

- By preventing rear wheel slip increase through rear wheel brake force (brake fluid pressure) control that is electronically controlled when slight skip on front and rear wheels are detected during braking, stability during braking is improved.
- EBD function is expanded and developed from conventional ABS function and corrects rear wheel brake force to appropriate level by electronic control according to load weight (number of passengers).

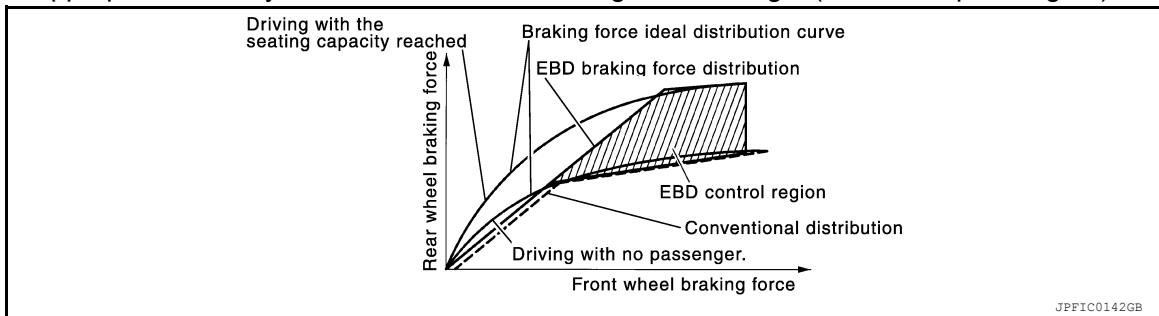

- During braking, control unit portion compares slight slip on front and rear wheels by wheel speed sensor signal, transmits drive signal to actuator portion when rear wheel slip exceeds front wheel slip for the specified value or more, and controls rear wheel brake force (brake fluid pressure) so that increase of rear wheel slip is prevented and slips on front wheel and rear wheel are nearly equalized. ABS control is applied when slip on each wheel increases and wheel speed is the threshold value of ABS control or less.
- CONSULT can be used to diagnose the system diagnosis.
- Fail-safe function is adopted. When a malfunction occurs in EBD function, the control is suspended for VDC function, TCS function, ABS function, EBD function, Brake limited slip differential (BLSD) function, Brake assist function, hill start assist function and Brake force distribution function. The vehicle status becomes the same as models without VDC function, TCS function, ABS function, EBD function, Brake limited slip differential (BLSD) function, Brake assist function, hill start assist function and Brake force distribution function. Refer to [BRC-20, "Fail-Safe"](#).

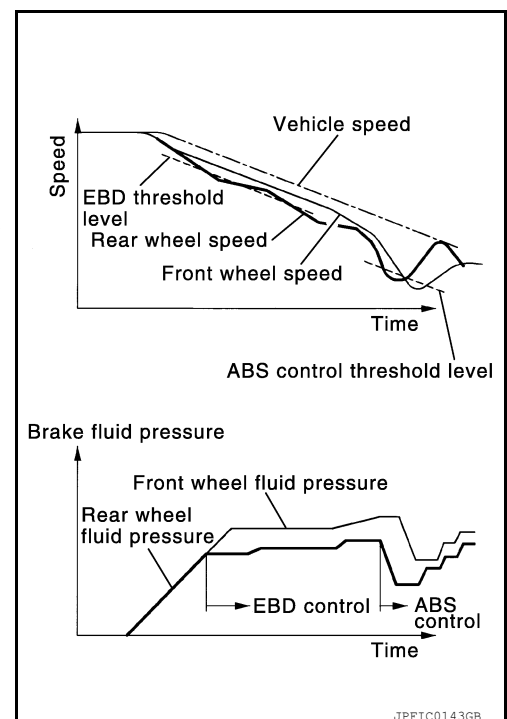

SYSTEM DIAGRAM

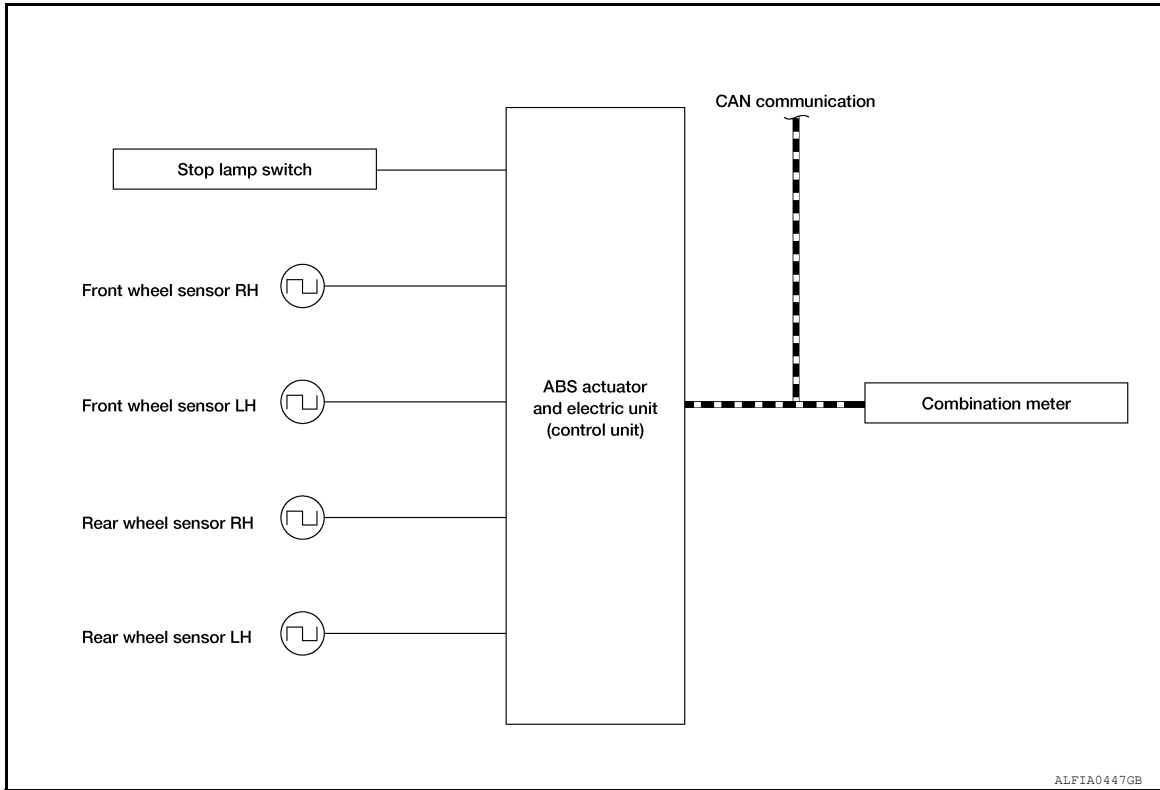

INPUT SIGNAL AND OUTPUT SIGNAL

Major signal transmission between each unit via communication lines is shown in the following table.

Component	Signal description
Combination meter	Mainly receives the following signals from ABS actuator and electric unit (control unit) via CAN communication: <ul style="list-style-type: none"> <li>• VDC warning lamp signal</li> <li>• ABS warning lamp signal</li> <li>• Brake warning lamp signal</li> </ul>

BRAKE LIMITED SLIP DIFFERENTIAL (BLSD) FUNCTION

BRAKE LIMITED SLIP DIFFERENTIAL (BLSD) FUNCTION : System Description

INFOID:0000000011280575

- LH and RH driving wheel spin is always monitored. If necessary, appropriate brake force is independently applied to LH or RH driving wheel so that one-sided wheel spin is avoided and traction is maintained. Mainly starting ability is improved.
- Brake limited slip differential (BLSD) function operates while VDC function is in non-operational status (OFF) by VDC OFF switch.
- VDC warning lamp blinking while Brake limited slip differential (BLSD) function is in operation and indicates to the driver that the function is in operation.
- Slight vibrations are felt on the Brake pedal and the operation noises occur, when Brake limited slip differential (BLSD) function operates. This is not a malfunction because it is caused by Brake limited slip differential (BLSD) function that is normally operated.
- Fail-safe function is adopted. When a malfunction occurs in brake limited slip differential (BLSD) function, the control is suspended for VDC function, TCS function, Brake limited slip differential (BLSD) function, Brake assist function, hill start assist function and Brake force distribution function. The vehicle status becomes the same as models without VDC function, TCS function, Brake limited slip differential (BLSD) function, Brake assist function, hill start assist function and Brake force distribution function. However, ABS function and EBD function are operated normally. Refer to [BRC-20. "Fail-Safe"](#).

# SYSTEM

< SYSTEM DESCRIPTION >

[VDC/TCS/ABS]

## SYSTEM DIAGRAM

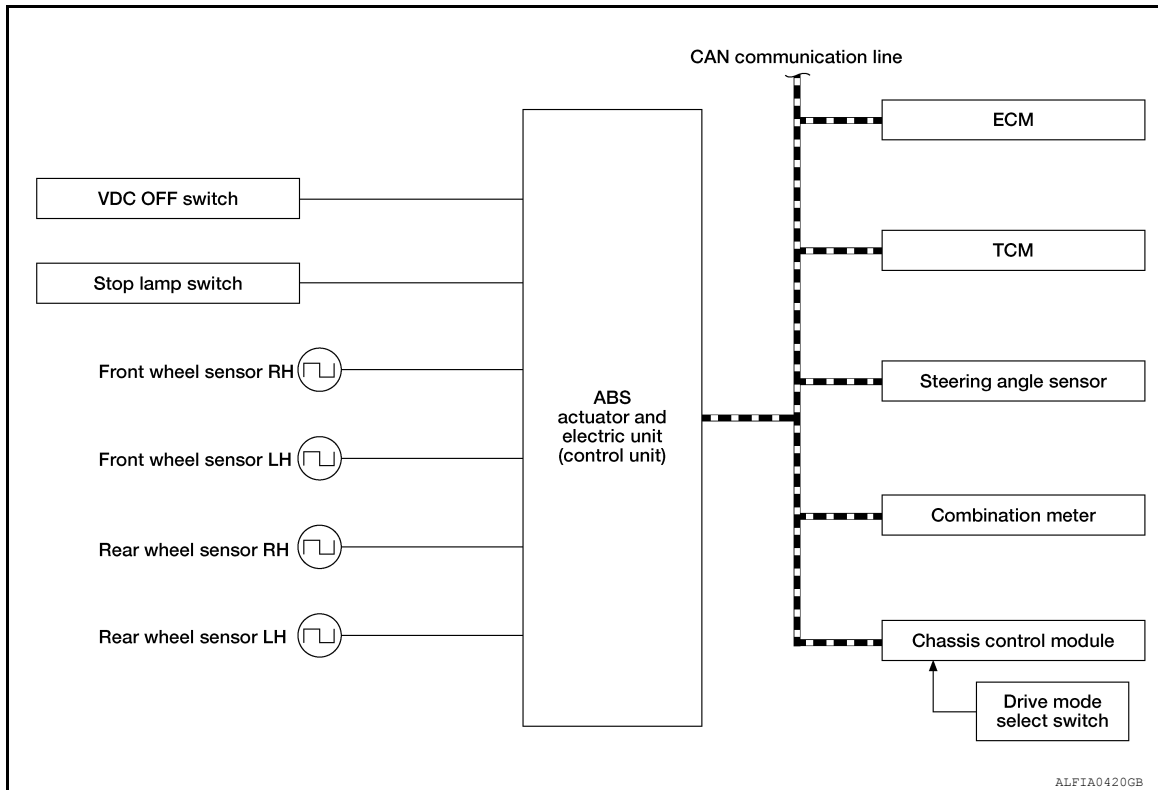

## INPUT SIGNAL AND OUTPUT SIGNAL

Major signal transmission between each unit via communication lines is shown in the following table.

Component	Signal description
ECM	Mainly transmits the following signals to ABS actuator and electric unit (control unit) via CAN communication: <ul style="list-style-type: none"> <li>• Accelerator pedal position signal</li> <li>• Engine speed signal</li> <li>• Engine torque signal</li> </ul> Mainly receives the following signal from ABS actuator and electric unit (control unit) via CAN communication: <ul style="list-style-type: none"> <li>• Engine torque request signal</li> </ul>
TCM	Mainly transmits the following signal to ABS actuator and electric unit (control unit) via CAN communication: <ul style="list-style-type: none"> <li>• Current gear position signal</li> </ul>
Chassis control module	Mainly transmits the following signal to ABS actuator and electric unit (control unit) via CAN communication: <ul style="list-style-type: none"> <li>• Active trace control signal</li> </ul>
Combination meter	Mainly receives the following signals from ABS actuator and electric unit (control unit) via CAN communication: <ul style="list-style-type: none"> <li>• Brake fluid level switch signal</li> <li>• Parking brake switch signal</li> </ul> Mainly receives the following signals from ABS actuator and electric unit (control unit) via CAN communication: <ul style="list-style-type: none"> <li>• VDC warning lamp signal</li> <li>• VDC OFF indicator lamp signal</li> </ul>
Steering angle sensor	Mainly transmits the following signals to ABS actuator and electric unit (control unit) via CAN communication: <ul style="list-style-type: none"> <li>• Steering angle sensor signal</li> <li>• Steering angle sensor malfunction signal</li> </ul>

## BRAKE ASSIST FUNCTION

# SYSTEM

< SYSTEM DESCRIPTION >

[VDC/TCS/ABS]

## BRAKE ASSIST FUNCTION : System Description

INFOID:000000011280576

- When the driver brakes hard in an emergency, the stopping distance is reduced by increasing brake fluid pressure.
- Fail-safe function is adopted. When a malfunction occurs in Brake assist function, the control is suspended for VDC function, TCS function, Brake limited slip differential (BLSD) function, Brake assist function, hill start assist function and Brake force distribution function. The vehicle status becomes the same as models without VDC function, TCS function, Brake limited slip differential (BLSD) function, Brake assist function, hill start assist function and Brake force distribution function. However, ABS function and EBD function are operated normally. Refer to [BRC-20, "Fail-Safe"](#).

### SYSTEM DIAGRAM

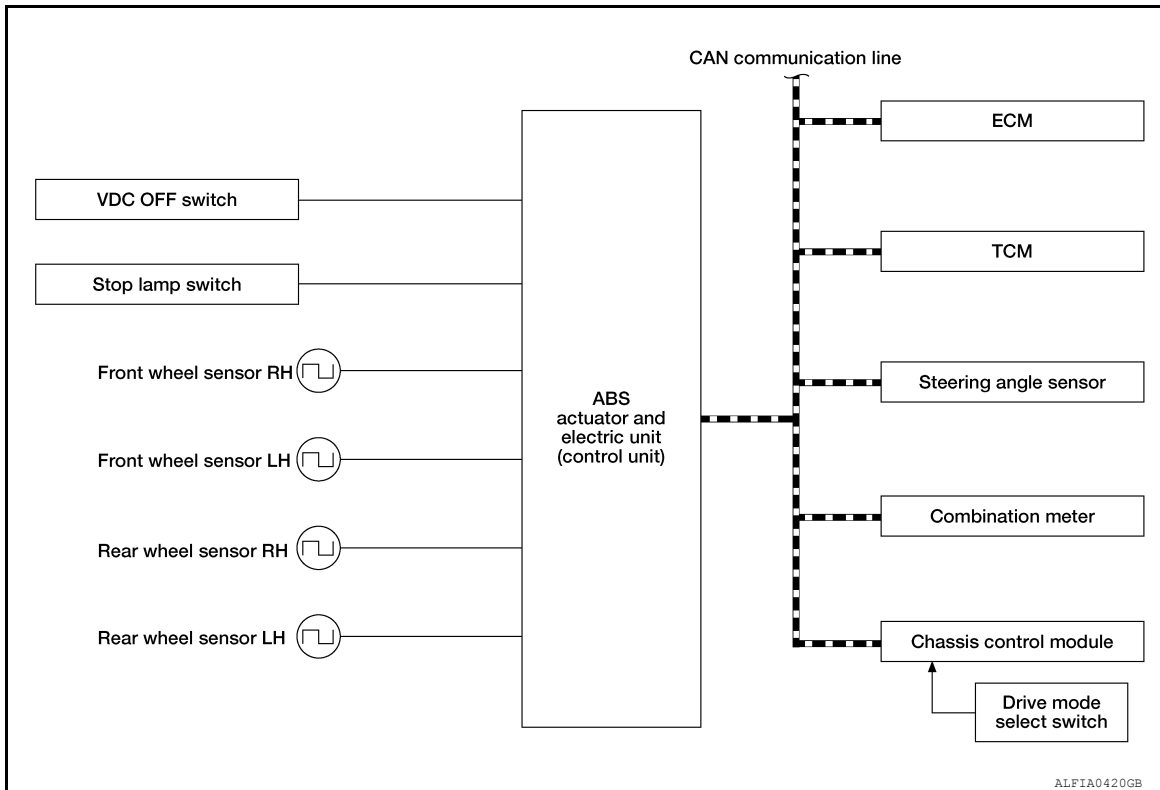

### INPUT SIGNAL AND OUTPUT SIGNAL

Major signal transmission between each unit via communication lines is shown in the following table.

Component	Signal description
ECM	Mainly transmits the following signal to ABS actuator and electric unit (control unit) via CAN communication: <ul style="list-style-type: none"> <li>• Accelerator pedal position signal</li> <li>• Engine speed signal</li> <li>• Engine torque signal</li> </ul> Mainly receives the following signal from ABS actuator and electric unit (control unit) via CAN communication: <ul style="list-style-type: none"> <li>• Engine torque request signal</li> </ul>
TCM	Mainly transmits the following signal to ABS actuator and electric unit (control unit) via CAN communication: <ul style="list-style-type: none"> <li>• Current gear position signal</li> </ul>
Chassis control module	Mainly transmits the following signal to ABS actuator and electric unit (control unit) via CAN communication: <ul style="list-style-type: none"> <li>• Active trace control signal</li> </ul>



# SYSTEM

< SYSTEM DESCRIPTION >

[VDC/TCS/ABS]

Component	Signal description
Combination meter	Mainly receives the following signals from ABS actuator and electric unit (control unit) via CAN communication: <ul style="list-style-type: none"> <li>• Brake fluid level switch signal</li> <li>• Parking brake switch signal</li> </ul> Mainly receives the following signals from ABS actuator and electric unit (control unit) via CAN communication: <ul style="list-style-type: none"> <li>• VDC warning lamp signal</li> <li>• VDC OFF indicator lamp signal</li> </ul>
Steering angle sensor	Mainly transmits the following signals to ABS actuator and electric unit (control unit) via CAN communication: <ul style="list-style-type: none"> <li>• Steering angle sensor signal</li> <li>• Steering angle sensor malfunction signal</li> </ul>

## hill descent control (Downhill Drive Support) FUNCTION

### hill descent control (Downhill Drive Support) FUNCTION : System Diagram INFOID:000000011280577

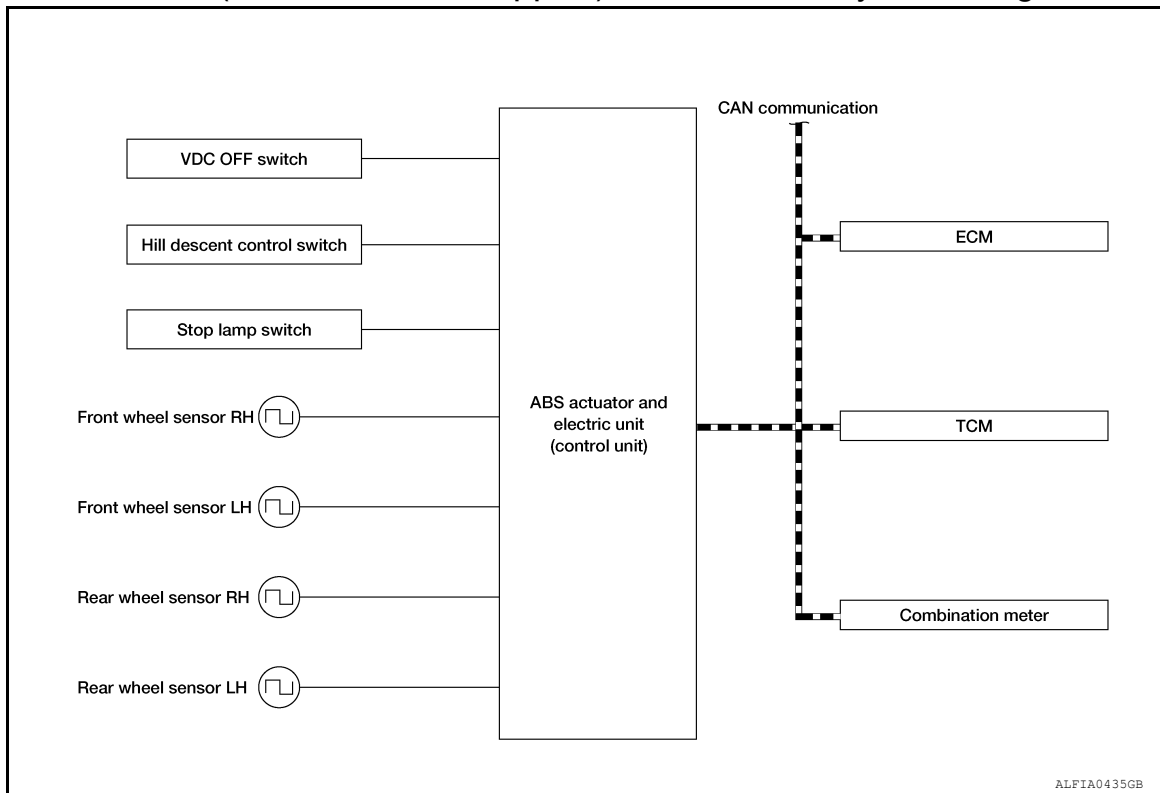

### hill descent control (Downhill Drive Support) FUNCTION : System Description INFOID:000000011280578

- The hill descent control system will help maintain vehicle speed when driving on steeper downhill grades. Hill descent control will provide braking allowing the driver to concentrate on steering while reducing the burden of brake and accelerator operation.
- To operate the system, push the hill descent control switch. the hill descent control indicator in the combination meter will turn on
- Hill start assist function is only for the start aid. It maintains the brake fluid pressure for approx. 2 seconds after releasing the brake pedal, and then decreases the pressure gradually. If the vehicle starts by the accelerator operation, the brake is released automatically and a smooth start can be performed.
- Fail-safe function is adopted. When a malfunction occurs in hill start assist function, the control is suspended for VDC function, TCS function, hill start assist function, Brake force distribution function and Active trace control function. The vehicle status becomes the same as models without VDC function, TCS function, hill start assist function, Brake force distribution function and Active trace control function. However, ABS function and EBD function are operated normally. Refer to [BRC-49, "Fail-Safe"](#).

#### INPUT SIGNAL AND OUTPUT SIGNAL

A  
B  
C  
D  
E  
G  
H  
I  
J  
K  
L  
M  
N  
O  
P

BRC

# SYSTEM

< SYSTEM DESCRIPTION >

[VDC/TCS/ABS]

Major signal transmission between each unit via communication lines is shown in the following table.

Component	Signal description
Yaw rate/side/decel G sensor	Mainly transmits the following signals to ABS actuator and electric unit (control unit) via communication line *: <ul style="list-style-type: none"> <li>• Yaw rate signal</li> <li>• Side G sensor signal</li> <li>• Decel G sensor signal</li> </ul>
ECM	Mainly transmits the following signals to ABS actuator and electric unit (control unit) via CAN communication: <ul style="list-style-type: none"> <li>• Accelerator pedal position signal</li> <li>• Engine speed signal</li> </ul> Mainly receives the following signal from ABS actuator and electric unit (control unit) via CAN communication: <ul style="list-style-type: none"> <li>• Target throttle position signal</li> </ul>
TCM	Mainly transmits the following signal to ABS actuator and electric unit (control unit) via CAN communication: <ul style="list-style-type: none"> <li>• Shift position signal</li> </ul>
Combination meter	Mainly transmits the following signals to ABS actuator and electric unit (control unit) via CAN communication: <ul style="list-style-type: none"> <li>• Brake fluid level switch signal</li> <li>• Parking brake switch signal</li> </ul> Mainly receives the following signals from ABS actuator and electric unit (control unit) via CAN communication: <ul style="list-style-type: none"> <li>• VDC warning lamp signal</li> <li>• VDC OFF indicator lamp signal</li> </ul>

\*: Communication line between yaw rate/side/decel G sensor and ABS actuator and electric unit (control unit)  
**hill start assist FUNCTION**

## hill start assist FUNCTION : System Description

INFOID:000000011280579

- This function maintains brake fluid pressure so that the vehicle does not move backwards even if brake pedal is released to depress accelerator pedal to start the vehicle while it is stopped on an uphill slope by depressing brake pedal.
- This function operates when the vehicle is in stop status on a uphill slope of slope ratio 10% or more and selector lever is in the position other than P or N.
- hill start assist function is only for the start aid. It maintains the brake fluid pressure for approx. 2 seconds after releasing the brake pedal, and then decreases the pressure gradually. If the vehicle can start by the accelerator operation, the brake is released automatically and a smooth start can be performed.
- Fail-safe function is adopted. When a malfunction occurs in hill start assist function, the control is suspended for VDC function, TCS function, Brake limited slip differential (BLSD) function, Brake assist function, hill start assist function and Brake force distribution function. The vehicle status becomes the same as models without VDC function, TCS function, Brake limited slip differential (BLSD) function, Brake assist function, hill start assist function and Brake force distribution function. However, ABS function and EBD function are operated normally. Refer to [BRC-20, "Fail-Safe"](#).

# SYSTEM

< SYSTEM DESCRIPTION >

[VDC/TCS/ABS]

## SYSTEM DIAGRAM

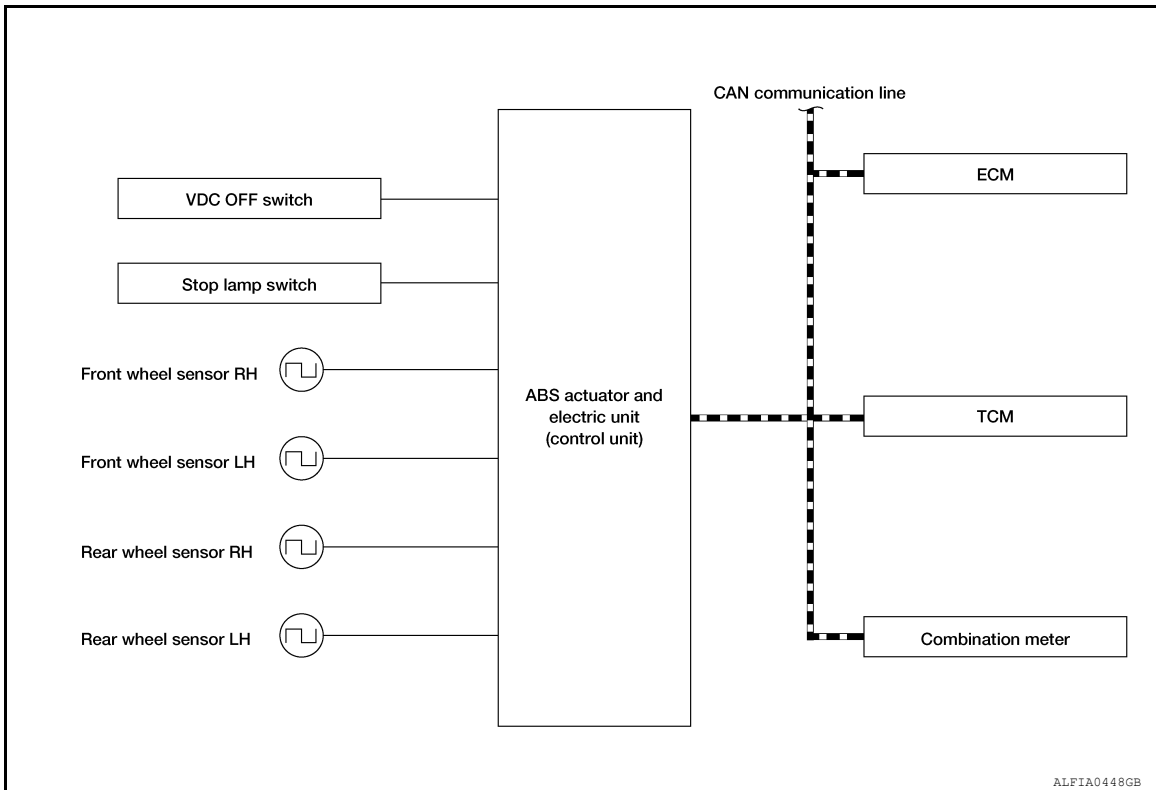

## INPUT SIGNAL AND OUTPUT SIGNAL

Major signal transmission between each unit via communication lines is shown in the following table.

Component	Signal description
ECM	<p>Mainly transmits the following signals to ABS actuator and electric unit (control unit) via CAN communication:</p> <ul style="list-style-type: none"> <li>• Accelerator pedal position signal</li> <li>• Engine speed signal</li> <li>• Engine torque signal</li> </ul> <p>Mainly receive: the following signal from ABS actuator and electric unit (control unit) via CAN communication:</p> <ul style="list-style-type: none"> <li>• Engine torque request signal</li> </ul>
TCM	<p>Mainly transmits the following signal to ABS actuator and electric unit (control unit) via CAN communication:</p> <ul style="list-style-type: none"> <li>• Current gear position signal</li> </ul>
Combination meter	<p>Mainly receives the following signals from ABS actuator and electric unit (control unit) via CAN communication:</p> <ul style="list-style-type: none"> <li>• Brake fluid level switch signal</li> <li>• Parking brake switch signal</li> </ul> <p>Mainly receives the following signals from ABS actuator and electric unit (control unit) via CAN communication:</p> <ul style="list-style-type: none"> <li>• VDC warning lamp signal</li> <li>• VDC OFF indicator lamp signal</li> </ul>

## BRAKE FORCE DISTRIBUTION FUNCTION

### BRAKE FORCE DISTRIBUTION FUNCTION : System Description

INFOID:000000011280580

- Brake force distribution function is controlled by ABS actuator and electric unit (control unit).

# SYSTEM

[VDC/TCS/ABS]

## < SYSTEM DESCRIPTION >

- Brake force distribution function helps provide a more stable and secure feeling.

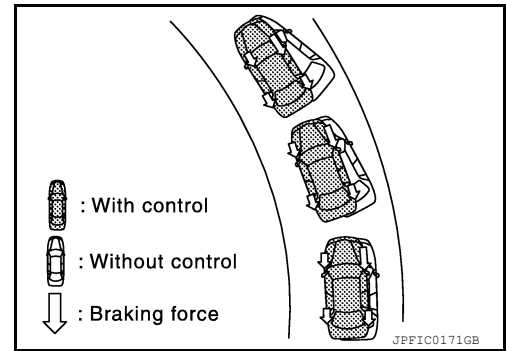

- During cornering, when brake operation is performed brake fluid pressure of each wheel is controlled based on steering operation amount by the driver and vehicle cornering status amount detected by each sensor.
- Fail-safe function is adopted. When a malfunction occurs in Brake force distribution function, the control is suspended for VDC function, TCS function, Brake limited slip differential (BLSD) function, Brake assist function, hill start assist function and Brake force distribution function. The vehicle status becomes the same as models without VDC function, TCS function, Brake limited slip differential (BLSD) function, Brake assist function, hill start assist function and Brake force distribution function. However, ABS function and EBD function are operated normally. Refer to [BRC-20. "Fail-Safe"](#).

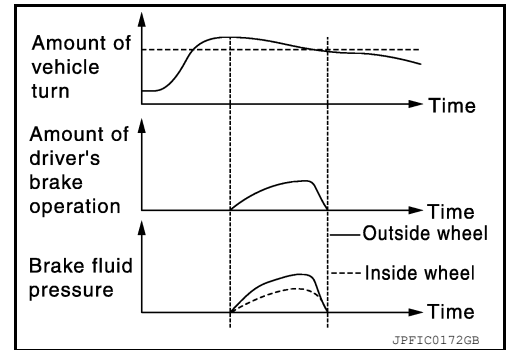

### NOTE:

Brake force distribution function may not always be operates in all driving conditions.

## SYSTEM DIAGRAM

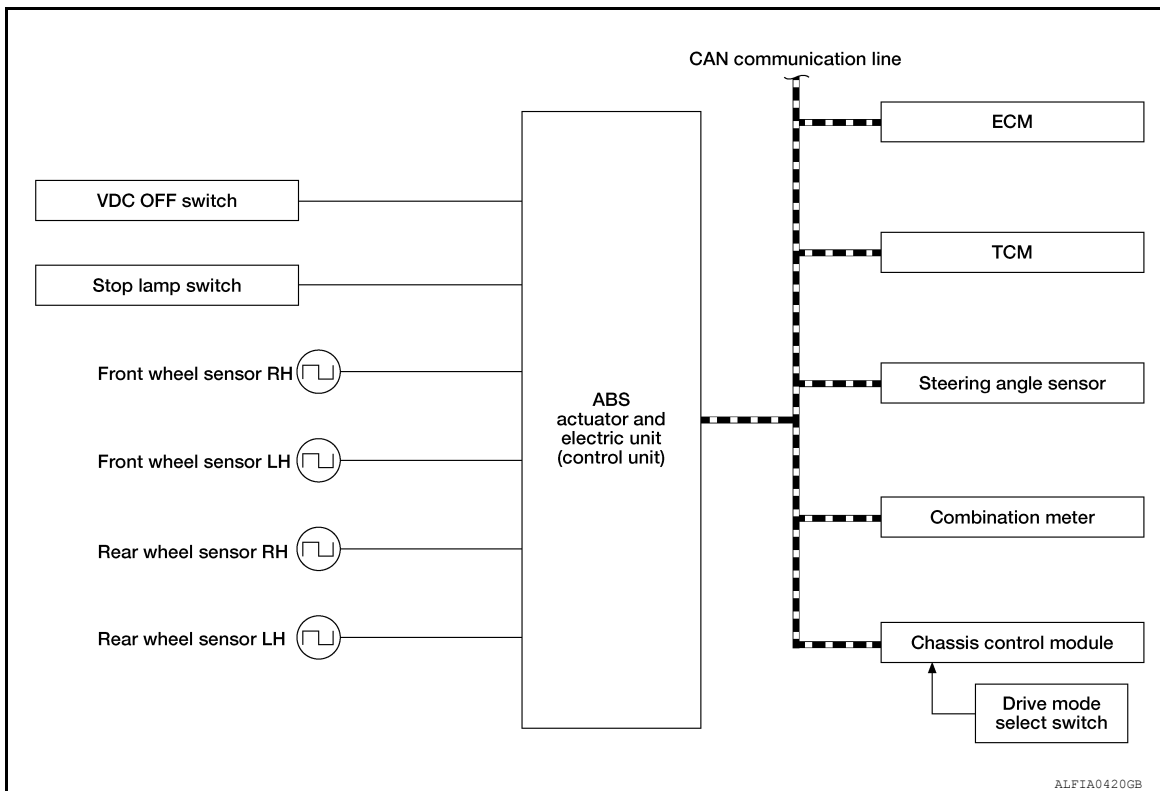

## INPUT SIGNAL AND OUTPUT SIGNAL

Major signal transmission between each unit via communication lines is shown in the following table.

# SYSTEM

< SYSTEM DESCRIPTION >

[VDC/TCS/ABS]

Component	Signal description
ECM	Mainly transmits the following signals to ABS actuator and electric unit (control unit) via CAN communication: <ul style="list-style-type: none"> <li>• Accelerator pedal position signal</li> <li>• Engine speed signal</li> <li>• Engine torque signal</li> </ul> Mainly receives the following signal from ABS actuator and electric unit (control unit) via CAN communication: <ul style="list-style-type: none"> <li>• Engine torque request signal</li> </ul>
TCM	Mainly transmits the following signal to ABS actuator and electric unit (control unit) via CAN communication: <ul style="list-style-type: none"> <li>• Current gear position signal</li> </ul>
Chassis control module	Mainly transmits the following signal to ABS actuator and electric unit (control unit) via CAN communication: <ul style="list-style-type: none"> <li>• Active trace control signal</li> </ul>
Combination meter	Mainly receives the following signals from ABS actuator and electric unit (control unit) via CAN communication: <ul style="list-style-type: none"> <li>• Brake fluid level switch signal</li> <li>• Parking brake switch signal</li> </ul> Mainly receives the following signals from ABS actuator and electric unit (control unit) via CAN communication: <ul style="list-style-type: none"> <li>• Brake warning lamp signal</li> <li>• ABS warning lamp signal</li> <li>• VDC warning lamp signal</li> <li>• VDC OFF indicator lamp signal</li> </ul>
Steering angle sensor	Mainly transmits the following signals to ABS actuator and electric unit (control unit) via CAN communication: <ul style="list-style-type: none"> <li>• Steering angle sensor signal</li> <li>• Steering angle sensor malfunction signal</li> </ul>

## ACTIVE TRACE CONTROL FUNCTION

### ACTIVE TRACE CONTROL FUNCTION : System Description

INFOID:000000011280581

- Active trace control function controls the braking utilizing the ABS actuator and electric unit (control unit), depending on cornering condition calculated from driver's steering input and plural sensors.
- Active trace control function is aimed to enhance traceability at corners and smooth the vehicle movement to provide confident driving.
- When the drive mode select switch is set to the "SPORT" mode, the amount of brake control provided by active trace control is reduced.
- For "PERSONAL" mode, the active trace control can be selected ON or OFF. Refer to [BRC-37. "ACTIVE TRACE CONTROL FUNCTION : System Description"](#).
- When the VDC OFF switch is used to turn OFF the VDC system, the active trace control system is also turned OFF.
- When the active trace control is operated, active trace control graphics are shown on the information display of combination meter. These are shown only when "Chassis control" is selected on the information display. Refer to [DAS-185. "System Description - Chassis Control"](#).
- When the active trace control is not functioning properly, the master warning lamp illuminates. Warning message "Chassis control" will also appear on information display.

**NOTE:**

- The active trace control may not be effective depending on the driving condition. Always driving carefully and attentively.
- Brake pedal may vibrate and brake pedal feel may change during active trace control operation. Also operation noise may be noticeable during operation. These are not abnormal conditions.
- When the active trace control is selected OFF, some functions will be kept ON to assist driver. (For example, avoidance condition.)

### OPERATION CHARACTERISTICS

# SYSTEM

[VDC/TCS/ABS]

## < SYSTEM DESCRIPTION >

Active trace control helps enhance the transition from braking into and then accelerating out of corners. Active trace control utilizes the vehicle's electrically-driven intelligent brake system to help improve cornering feel by automatically applying brakes. Furthermore, Active trace control will apply selective braking to help create increased steering response in S-turns. For example, if driving through an S-turn that starts with steering to the right, the right-side brakes are engaged to create a yaw momentum and help turn the vehicle.

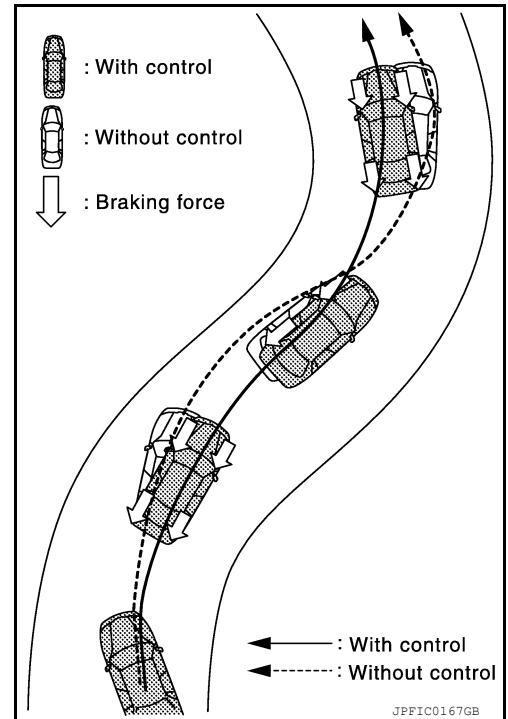

- Brake control amount is controlled according to steering operation status by the driver and vehicle cornering status.

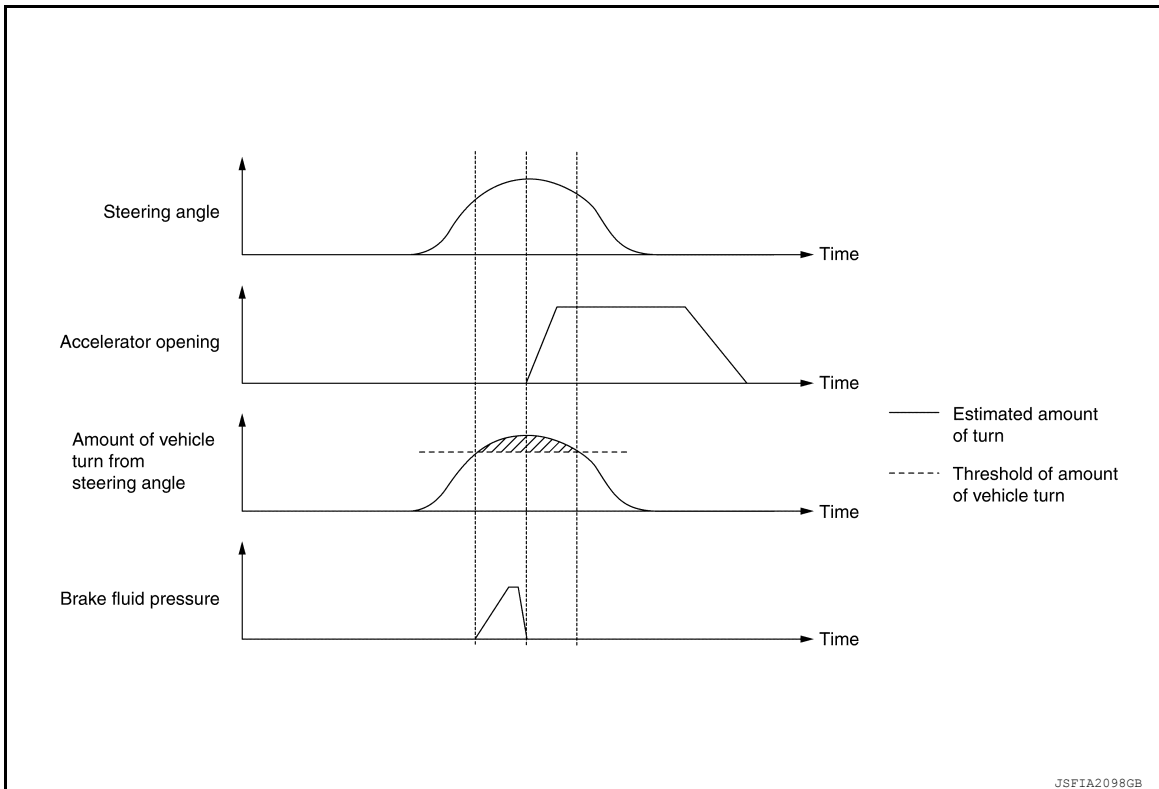

# SYSTEM

[VDC/TCS/ABS]

## < SYSTEM DESCRIPTION >

- During cornering, the brake control system limits changes in steering angle by controlling the inner ring brakes according to accelerator pedal operation and allows smooth movement of the vehicle to achieve stable cornering.

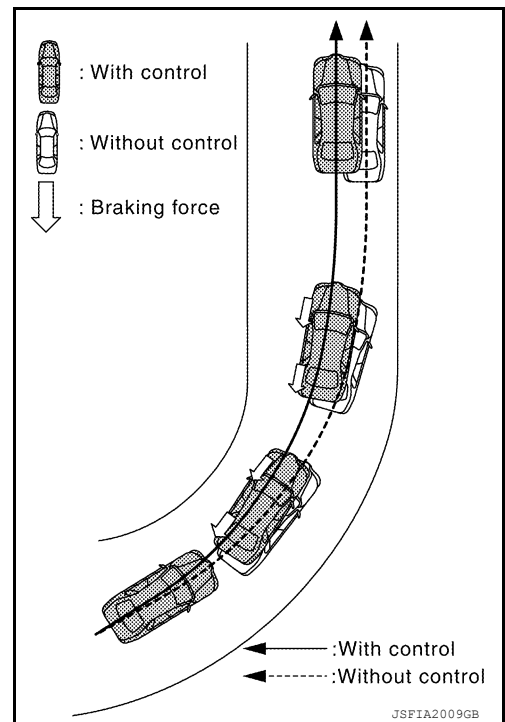

A  
B  
C  
D  
E  
BRC

## SYSTEM DIAGRAM

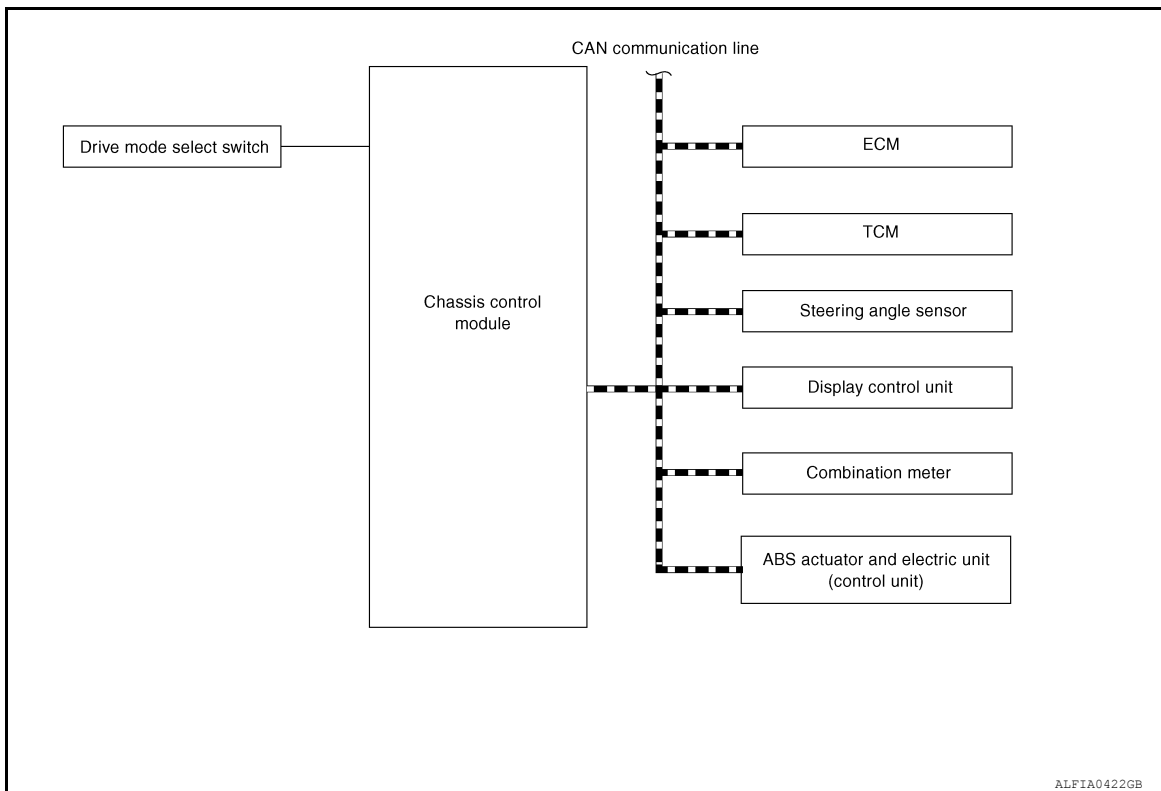

G  
H  
I  
J  
K  
L  
M  
N  
O  
P

## INPUT SIGNAL AND OUTPUT SIGNAL

Major signal transmission between each unit via communication lines is shown in the following table.

# SYSTEM

< SYSTEM DESCRIPTION >

[VDC/TCS/ABS]

Component	Signal description
ECM	Mainly transmits the following signals to chassis control module via CAN communication: <ul style="list-style-type: none"><li>• Accelerator pedal position signal</li><li>• Engine torque signal</li><li>• Engine speed signal</li></ul>
TCM	Mainly transmits the following signal to chassis control module via CAN communication: <ul style="list-style-type: none"><li>• Current gear position signal</li></ul>
ABS actuator and electric unit (control unit)	Mainly transmits the following signals to chassis control module via CAN communication: <ul style="list-style-type: none"><li>• Front LH wheel speed signal</li><li>• Front RH wheel speed signal</li><li>• Rear LH wheel speed signal</li><li>• Rear RH wheel speed signal</li><li>• ABS operation signal</li><li>• TCS operation signal</li><li>• VDC operation signal</li><li>• Stop lamp switch signal</li><li>• Vehicle speed signal (ABS)</li><li>• Yaw rate signal</li><li>• Side G signal</li><li>• Decel G signal</li><li>• VDC OFF switch signal</li><li>• Brake fluid pressure signal</li><li>• Steering angle sensor signal</li></ul> Mainly receives the following signal from chassis control module via CAN communication: <ul style="list-style-type: none"><li>• Active trace control signal</li></ul>
Steering angle sensor	Mainly transmits the following signal to chassis control module via CAN communication: <ul style="list-style-type: none"><li>• Steering angle sensor signal</li></ul>
Chassis control module	Mainly transmits the following signals to ABS actuator and electric unit (control unit) via CAN communication: <ul style="list-style-type: none"><li>• Active Trace Control signal</li><li>• Drive mode signal</li></ul>
Display control unit	Mainly transmits the following signal to chassis control module via CAN communication line: <ul style="list-style-type: none"><li>• System selection signal</li></ul>
Combination meter	Mainly receives the following signals from chassis control module via CAN communication: <ul style="list-style-type: none"><li>• Chassis control malfunction signal</li><li>• Active trace control display signal</li></ul>
Drive mode select switch	Mainly transmits the following signal to chassis control module: <ul style="list-style-type: none"><li>• Drive mode signal</li></ul>

## WARNING/INDICATOR/CHIME LIST

### WARNING/INDICATOR/CHIME LIST : Warning Lamp/Indicator Lamp





INFOID:000000011280582



# SYSTEM

< SYSTEM DESCRIPTION >

[VDC/TCS/ABS]

Name	Design	Layout/Function
ABS warning lamp	<p>ABS</p> <p>or</p> 	For function: Refer to <a href="#">BRC-117. "Component Function Check"</a> .
Brake warning lamp	<p>BRAKE</p> <p>or</p> 	For function: Refer to <a href="#">BRC-118. "Component Function Check"</a> .
VDC OFF indicator lamp		For function: Refer to <a href="#">BRC-121. "Component Function Check"</a> .
VDC warning lamp		For function: Refer to <a href="#">BRC-120. "Component Function Check"</a> .

A  
B  
C  
D  
E  
G  
H  
I  
J  
K  
L  
M  
N  
O  
P

BRC

# DIAGNOSIS SYSTEM [ABS ACTUATOR AND ELECTRIC UNIT (CONTROL UNIT)]

< SYSTEM DESCRIPTION >

[VDC/TCS/ABS]

## DIAGNOSIS SYSTEM [ABS ACTUATOR AND ELECTRIC UNIT (CONTROL UNIT)]

### CONSULT Function

INFOID:000000011280583

### APPLICATION ITEMS

CONSULT can display each diagnostic item using the diagnostic test modes as follows.

Mode	Function description
ECU identification	Parts number of ABS actuator and electric unit (control unit) can be read.
Self Diagnostic Result	"Self Diagnostic Result" and freeze frame data can be read and erased quickly.*
Data Monitor	Input/Output data in the ABS actuator and electric unit (control unit) can be read.
ACTIVE TEST	Diagnostic Test Mode in which CONSULT drives some actuators apart from the ABS actuator and electric unit (control unit) and also shifts some parameters in a specified range.
Work support	Components can be quickly and accurately adjusted.
Re/programming, Configuration	<ul style="list-style-type: none"><li>• Read and save the vehicle specification (TYPE ID).</li><li>• Write the vehicle specification (TYPE ID) when replacing ABS actuator and electric unit (control unit).</li></ul>

\*: The following diagnosis information is erased by erasing.

- DTC
- Freeze frame data (FFD)

### ECU IDENTIFICATION

ABS actuator and electric unit (control unit) part number can be read.

### SELF DIAGNOSTIC RESULT

Refer to [BRC-53, "DTC Index"](#).

When "CRNT" is displayed on "Self Diagnostic Result",

- The system is presently malfunctioning.

When "PAST" is displayed on "Self Diagnostic Result",

- System malfunction in the past is detected, but the system is presently normal.

Freeze frame data (FFD)

The following vehicle status is recorded when DTC is detected and is displayed on CONSULT.

Item name	Display item
IGN counter (0 – 39)	<p>The number of times that ignition switch is turned ON after the DTC is detected is displayed.</p> <ul style="list-style-type: none"><li>• When "0" is displayed: It indicates that the system is presently malfunctioning.</li><li>• When except "0" is displayed: It indicates that system malfunction in the past is detected, but the system is presently normal.</li></ul> <p><b>NOTE:</b> Each time when ignition switch is turned OFF to ON, numerical number increases in 1 → 2 → 3...38 → 39. When the operation number of times exceeds 39, the number do not increase and "39" is displayed until self-diagnosis is erased.</p>

### ACTIVE TEST

The active test is used to determine and identify details of a malfunction, based on self-diagnosis test results and data obtained in the DATA MONITOR. In response to instructions from CONSULT, instead of those from ABS actuator and electric unit (control unit) on the vehicle, a drive signal is sent to the actuator to check its operation.

#### CAUTION:

- **Never perform ACTIVE TEST while driving the vehicle.**
- **Always bleed air from brake system before active test.**
- **Never perform active test when system is malfunctioning.**

#### NOTE:

- When active test is performed while depressing the pedal, the pedal depressing stroke may change. This is not a malfunction.
- "TEST IS STOPPED" is displayed approx. 10 seconds after operation start.

# DIAGNOSIS SYSTEM [ABS ACTUATOR AND ELECTRIC UNIT (CONTROL UNIT)]

< SYSTEM DESCRIPTION >

[VDC/TCS/ABS]

- When performing active test again after “TEST IS STOPPED” is displayed, select “BACK”.
- ABS warning lamp, brake warning lamp and VDC warning lamp may turn ON during active test. This is not a malfunction.

## ABS IN Valve and ABS OUT Valve

When “Up”, “Keep” or “Down” is selected on display screen, the following items are displayed when system is normal.

Test item	Display Item	Display		
		Up	Keep	Down
FR RH SOL	FR RH IN SOL	Off	On*	On*
	FR RH OUT SOL	Off	Off	On*
	CV2	Off	Off	Off
FR LH SPL	FR LH IN SOL	Off	On*	On*
	FR LH OUT SOL	Off	Off	On*
	CV1	Off	Off	Off
RR RH SOL	RR RH IN SOL	Off	On*	On*
	RR RH OUT SOL	Off	Off	On*
	CV1	Off	Off	Off
RR LH SOL	RR LH IN SOL	Off	On*	On*
	RR LH OUT SOL	Off	Off	On*
	CV2	Off	Off	Off

\*: Immediately after being selected, status is “On”. Status changes to “Off” after approx. 2 seconds.

## ABS IN Valve (ACT) and ABS OUT Valve (ACT)

When “Up”, “ACT UP” or “ACT KEEP” is selected on display screen, the following items are displayed when system is normal.

Test item	Display Item	Display		
		Up	ACT UP	ACT KEEP
FR RH SOL (ACT)	FR RH IN SOL	Off	Off	Off
	FR RH OUT SOL	Off	Off	Off
	CV2	Off	On*	On*
FR LH SOL (ACT)	FR LH IN SOL	Off	Off	Off
	FR LH OUT SOL	Off	Off	Off
	CV1	Off	On*	On*
RR RH SOL (ACT)	RR RH IN SOL	Off	Off	Off
	RR RH OUT SOL	Off	Off	Off
	CV1	Off	On*	On*
RR LH SOL (ACT)	RR LH IN SOL	Off	Off	Off
	RR LH OUT SOL	Off	Off	Off
	CV2	Off	On*	On*

\*: Immediately after being selected, status is “On”. Status changes to “Off” after approx. 10 seconds.

## ABS MOTOR

When “On” or “Off” is selected on display screen, the following items are displayed when system is normal.

Test item	Display Item	Display	
		On	Off
ABS MOTOR	MOTOR RELAY	On	Off
	ACTUATOR RLY <sup>(Note)</sup>	On	On

# DIAGNOSIS SYSTEM [ABS ACTUATOR AND ELECTRIC UNIT (CONTROL UNIT)]

< SYSTEM DESCRIPTION >

[VDC/TCS/ABS]

**NOTE:**

Display occasionally changes On/Off for a moment after ignition switch is turned ON. This is operation for checking purposes and is not a malfunction.

**DATA MONITOR**

**NOTE:**

The following table includes information (items) inapplicable to this vehicle. For information (items) applicable to this vehicle, refer to CONSULT display items.

×: Applicable

Item (Unit)	Monitor item selection		Note
	INPUT SIGNALS	MAIN SIGNALS	
FR LH SENSOR [km/h (MPH)]	×	×	Wheel speed calculated by front LH wheel sensor is displayed.
FR RH SENSOR [km/h (MPH)]	×	×	Wheel speed calculated by front RH wheel sensor is displayed.
RR LH SENSOR [km/h (MPH)]	×	×	Wheel speed calculated by rear LH wheel sensor is displayed.
RR RH SENSOR [km/h (MPH)]	×	×	Wheel speed calculated by rear RH wheel sensor is displayed.
DECEL G-SEN (m/s <sup>2</sup> )	×	×	Decel G detected by decel G sensor is displayed.
FR RH IN SOL (On/Off)		×	Operation status of front RH wheel ABS IN valve is displayed.
FR RH OUT SOL (On/Off)		×	Operation status of front RH wheel ABS OUT valve is displayed.
FR LH IN SOL (On/Off)		×	Operation status of front LH wheel ABS IN valve is displayed.
FR LH OUT SOL (On/Off)		×	Operation status of front LH wheel ABS OUT valve is displayed.
RR RH IN SOL (On/Off)		×	Operation status of rear RH wheel ABS IN valve is displayed.
RR RH OUT SOL (On/Off)		×	Operation status of rear RH wheel ABS OUT valve is displayed.
RR LH IN SOL (On/Off)		×	Operation status of rear LH wheel ABS IN valve is displayed.
RR LH OUT SOL (On/Off)		×	Operation status of rear LH wheel ABS OUT valve is displayed.
EBD WARN LAMP (On/Off)			Brake warning lamp ON/OFF status is displayed. (Note 1)
STOP LAMP SW (On/Off)	×	×	Stop lamp switch signal input status is displayed.
MOTOR RELAY (On/Off)		×	ABS motor and motor relay status is displayed.
ACTUATOR RLY (On/Off)		×	ABS actuator relay status is displayed.
ABS WARN LAMP (On/Off)		×	ABS warning lamp ON/OFF status is displayed. (Note 1)
OFF LAMP (On/Off)		×	VDC OFF indicator lamp ON/OFF status is displayed. (Note 1)
SLIP/VDC LAMP (On/Off)		×	VDC warning lamp ON/OFF status is displayed. (Note 1)
BATTERY VOLT (V)	×	×	Voltage supplied to ABS actuator and electric unit (control unit) is displayed.
GEAR	×	×	Current gear position judged from current gear position signal is displayed.

# DIAGNOSIS SYSTEM [ABS ACTUATOR AND ELECTRIC UNIT (CONTROL UNIT)]

< SYSTEM DESCRIPTION >

[VDC/TCS/ABS]

Item (Unit)	Monitor item selection		Note	
	INPUT SIGNALS	MAIN SIGNALS		
SLCT LVR POSI	×	×	Current gear position judged from current gear position signal is displayed.	A
YAW RATE SEN (d/s)	×	×	Yaw rate detected by yaw rate sensor is displayed.	B
R POSI SIG (On/Off)			R range signal input status judged from R range signal is displayed.	C
4WD MODE MON <sup>(Note 2)</sup> (AUTO/LOCK/2WD)	×	×	AWD control status is displayed.	D
N POSI SIG (On/Off)			N range signal input status judged from N range signal is displayed.	E
P POSI SIG (On/Off)			P range signal input status judged from P range signal is displayed.	E
ACCEL POS SIG (%)	×		Displays the Accelerator pedal position	BRC
SIDE G-SENSOR (m/s <sup>2</sup> )	×		Side G detected by side G sensor is displayed.	
STR ANGLE SIG	×		Steering angle detected by steering angle sensor is displayed.	G
PRESS SENSOR (bar)	×		Brake fluid pressure detected by pressure sensor is displayed.	H
EBD SIGNAL (On/Off)			EBD operation status is displayed.	I
ABS SIGNAL (On/Off)			ABS operation status is displayed.	I
TCS SIGNAL (On/Off)			TCS operation status is displayed.	J
VDC SIGNAL (On/Off)			VDC operation status is displayed.	J
EBD FAIL SIG (On/Off)			EBD fail-safe signal status is displayed.	K
ABS FAIL SIG (On/Off)			ABS fail-safe signal status is displayed.	L
TCS FAIL SIG (On/Off)			TCS fail-safe signal status is displayed.	L
VDC FAIL SIG (On/Off)			VDC fail-safe signal status is displayed.	M
CRANKING SIG (On/Off)			Cranking status is displayed.	N
FLUID LEV SW (On/Off)	×		Brake fluid level signal input status via CAN communication is displayed.	N
PARK BRAKE SW (On/Off)	×		Parking brake switch signal input status via CAN communication is displayed.	O
USV[FL-RR] (On/Off)			Primary side USV solenoid valve (On/Off) status is displayed.	P
USV[FR-RL] (On/Off)			Secondary side USV solenoid valve (On/Off) status is displayed.	P
HSV[FL-RR] (On/Off)			Primary side HSV solenoid valve (On/Off) status is displayed.	
HSV[FR-RL] (On/Off)			Secondary side USV solenoid valve (On/Off) status is displayed.	

# DIAGNOSIS SYSTEM [ABS ACTUATOR AND ELECTRIC UNIT (CONTROL UNIT)]

< SYSTEM DESCRIPTION >

[VDC/TCS/ABS]

Item (Unit)	Monitor item selection		Note
	INPUT SIGNALS	MAIN SIGNALS	
V/R OUTPUT (On/Off)			Valve relay operation signal (On/Off) status is displayed.
M/R OUTPUT (On/Off)			Motor relay operation signal (On/Off) status is displayed.
ENGINE RPM (tr/min)	×		Engine speed status is displayed.
DDS SW <sup>(Note 3)</sup>			Downhill Drive Support switch status is displayed.
DDS SIG <sup>(Note 3)</sup>			Downhill Drive Support operation status is displayed.
USS SIG <sup>(Note 4)</sup> (On/Off)			hill start assist operation status is displayed.

Note 1: Refer to [BRC-12. "System Description"](#) for ON/OFF conditions of each warning lamp and indicator lamp.

Note 2: AWD models

Note 3: DDS (Downhill Drive Support)

Note 4: USS (Hill Start Assist)

## WORK SUPPORT

Conditions	Description
ST ANGLE SENSOR ADJUSTMENT	Perform neutral position adjustment of steering angle sensor.
DECEL G SEN CALIBRATION	Perform decel G sensor calibration.

# ABS ACTUATOR AND ELECTRIC UNIT (CONTROL UNIT)

< ECU DIAGNOSIS INFORMATION >

[VDC/TCS/ABS]

## ECU DIAGNOSIS INFORMATION

### ABS ACTUATOR AND ELECTRIC UNIT (CONTROL UNIT)

#### Reference Value

INFOID:0000000011280584

#### CONSULT DATA MONITOR STANDARD VALUE

**NOTE:**

The following table includes information (items) inapplicable to this vehicle. For information (items) applicable to this vehicle, refer to CONSULT display items.

Monitor item	Condition	Reference values in normal operation
FR LH SENSOR	Vehicle stopped	0.00 km/h (MPH)
	When driving <sup>(Note 1)</sup>	Nearly matches the speedometer display (within ±10%)
FR RH SENSOR	Vehicle stopped	0.00 km/h (MPH)
	When driving <sup>(Note 1)</sup>	Nearly matches the speedometer display (within ±10%)
RR LH SENSOR	Vehicle stopped	0.00 km/h (MPH)
	When driving <sup>(Note 1)</sup>	Nearly matches the speedometer display (within ±10%)
RR RH SENSOR	Vehicle stopped	0.00 km/h (MPH)
	When driving <sup>(Note 1)</sup>	Nearly matches the speedometer display (within ±10%)
BATTERY VOLT	Ignition switch ON	10 – 16 V
STOP LAMP SW	Brake pedal depressed	On
	Brake pedal not depressed	Off
OFF SW	VDC OFF switch ON	On
	VDC OFF switch OFF	Off
YAW RATE SEN	Vehicle stopped	Approx. 0 d/s
	Turning right	Negative value
	Turning left	Positive value
FR RH IN SOL	Active	On
	Not activated	Off
FR RH OUT SOL	Active	On
	Not activated	Off
FR LH IN SOL	Active	On
	Not activated	Off
FR LH OUT SOL	Active	On
	Not activated	Off
RR RH IN SOL	Active	On
	Not activated	Off
RR RH OUT SOL	Active	On
	Not activated	Off
RR LH IN SOL	Active	On
	Not activated	Off
RR LH OUT SOL	Active	On
	Not activated	Off

# ABS ACTUATOR AND ELECTRIC UNIT (CONTROL UNIT)

< ECU DIAGNOSIS INFORMATION >

[VDC/TCS/ABS]

Monitor item	Condition	Reference values in normal operation
MOTOR RELAY	Active	On
	Not activated	Off
ACTUATOR RLY	Active	On
	When not operating (in fail-safe mode)	Off
ABS WARN LAMP	When ABS warning lamp is ON <sup>(Note 2)</sup>	On
	When ABS warning lamp is OFF <sup>(Note 2)</sup>	Off
OFF LAMP	When VDC OFF indicator lamp is ON <sup>(Note 2)</sup>	On
	When VDC OFF indicator lamp is OFF <sup>(Note 2)</sup>	Off
SLIP/VDC LAMP	When VDC warning lamp is ON <sup>(Note 2)</sup>	On
	When VDC warning lamp is OFF <sup>(Note 2)</sup>	Off
ACCEL POS SIG	Never depress accelerator pedal (with ignition switch ON)	0%
	Depress accelerator pedal (with ignition switch ON)	0 – 100%
SIDE G-SENSOR	Vehicle stopped	Approx. 0 m/s <sup>2</sup>
	Right turn	Negative value
	Left turn	Positive value
DECEL G-SEN	When stopped	Approx. ±0.01 G
	During acceleration	Positive value
	During deceleration	Negative value
STR ANGLE SIG	When driving straight	0±3.5°
	When steering wheel is steered to RH by 90°	Approx. +90°
	When steering wheel is steered to LH by 90°	Approx. -90°
ENGINE SPEED	Engine stopped	0 tr/min
	Engine running	Almost same reading as tachometer
PRESS SENSOR	Brake pedal not depressed	Approx. 0 bar
	Brake pedal depressed	(-40) – (+300 bar)
FLUID LEV SW	When brake fluid level switch is ON (brake fluid level is less than the specified level)	On
	When brake fluid level switch is OFF	Off
PARK BRAKE SW	When parking brake is active	On
	Parking brake is released	Off
CV1	Active	On
	Not activated	Off
CV2	Active	On
	Not activated	Off
EBD SIGNAL	EBD activated	On
	EBD not activated	Off
ABS SIGNAL	ABS is activated	On
	ABS is not activated	Off
TCS SIGNAL	TCS activated	On
	TCS not activated	Off
VDC SIGNAL	VDC activated	On
	VDC not activated	Off



# ABS ACTUATOR AND ELECTRIC UNIT (CONTROL UNIT)

< ECU DIAGNOSIS INFORMATION >

[VDC/TCS/ABS]

Monitor item	Condition	Reference values in normal operation
EBD FAIL SIG	In EBD fail-safe	On
	EBD is normal	Off
ABS FAIL SIG	In ABS fail-safe	On
	ABS is normal	Off
TCS FAIL SIG	In TCS fail-safe	On
	TCS is normal	Off
VDC FAIL SIG	In VDC fail-safe	On
	VDC is normal	Off
CRANKING SIG	At cranking	On
	Other than at cranking	Off
EBD WARN LAMP	When brake warning lamp is ON <sup>(Note 2)</sup>	On
	When brake warning lamp is OFF <sup>(Note 2)</sup>	Off
GEAR	Driving	1 – 7 Depending on shift status
N POSI SIG	When selector lever is in the N position	On
	When selector lever is in the other position than N	Off
R POSI SIG	When selector lever is in the R position	On
	When selector lever is in the other position than R	Off
4WD MODE MON <sup>(Note 3)</sup>	Always	AUTO, LOCK, 2WD (depending on AWD control status)
DDS SW <sup>(Note 4)</sup> (On/Off)	Hill descent switch ON	On
	Hill Descent switch OFF	Off
DDS SIG <sup>(Note 4)</sup> (On/Off)	When hill descent control is active	On
	When hill descent control is inactive	Off
USS SIG <sup>(Note 5)</sup>	When hill start assist is active	On
	When hill start assist is not active	Off

Note 1: Confirm tire pressure is standard value.

Note 2: Refer to [BRC-12. "System Description"](#) for ON/OFF conditions of each warning lamp and indicator lamp.

Note 3: AWD models

Note 4: DDS (Downhill Drive Support)

Note 5: USS (Hill Start Assist)

## Fail-Safe

INFOID:0000000011280585

### VDC FUNCTION, TCS FUNCTION, BRAKE LIMITED SLIP DIFFERENTIAL FUNCTION, BRAKE ASSIST FUNCTION, hill start assist FUNCTION AND BRAKE FORCE DISTRIBUTION FUNCTION

VDC warning lamp in combination meter turn ON when a malfunction occurs in system [ABS actuator and electric unit (control unit)]. The control is suspended for VDC function, TCS function, Brake limited slip differential (BLSD) function, Brake assist function, hill start assist function and Brake force distribution function. The vehicle status becomes the same as models without VDC function, TCS function, Brake limited slip differential (BLSD) function, Brake assist function, hill start assist function and Brake force distribution function. However, ABS function and EBD function are operated normally.

### ABS FUNCTION

ABS warning lamp and VDC warning lamp in combination meter turn ON when a malfunction occurs in system [ABS actuator and electric unit (control unit)]. The control is suspended for VDC function, TCS function, ABS function, Brake limited slip differential (BLSD) function, Brake assist function, hill start assist function and Brake force distribution function. The vehicle status becomes the same as models without VDC function, TCS function, ABS function, Brake limited slip differential (BLSD) function, Brake assist function, hill start assist function and Brake force distribution function. However, EBD function is operated normally.

# ABS ACTUATOR AND ELECTRIC UNIT (CONTROL UNIT)

< ECU DIAGNOSIS INFORMATION >

[VDC/TCS/ABS]

## NOTE:

ABS self-diagnosis sound may be heard the same as in the normal condition, because self-diagnosis is performed when ignition switch turns ON and when vehicle initially starts.

## EBD FUNCTION

ABS warning lamp, brake warning lamp and VDC warning lamp in combination meter turn ON when a malfunction occurs in system [ABS actuator and electric unit (control unit)]. The control is suspended for VDC function, TCS function, ABS function, EBD function, Brake limited slip differential (BLSD) function, Brake assist function, hill start assist function and Brake force distribution function. The vehicle status becomes the same as models without VDC function, TCS function, ABS function, EBD function, Brake limited slip differential (BLSD) function, Brake assist function, hill start assist function and Brake force distribution function.

DTC	Fail-safe condition
C1101	The following functions are suspended: <ul style="list-style-type: none"><li>• VDC function</li><li>• TCS function</li><li>• ABS function</li><li>• EBD function (only when both 2 rear wheels are malfunctioning)</li><li>• Brake limited slip differential (BLSD) function</li><li>• Brake assist function</li><li>• hill start assist function</li><li>• hill descent function</li><li>• Brake force distribution function</li><li>• Active trace control function (control of chassis control module)</li></ul>
C1102	
C1103	
C1104	
C1105	
C1106	
C1107	
C1108	
C1109	The following functions are suspended: <ul style="list-style-type: none"><li>• VDC function</li><li>• TCS function</li><li>• ABS function</li><li>• EBD function</li><li>• Brake limited slip differential (BLSD) function</li><li>• Brake assist function</li><li>• hill start assist function</li><li>• hill descent function</li><li>• Brake force distribution function</li><li>• Active trace control function (control of chassis control module)</li></ul>
C1111	
C1113	The following functions are suspended: <ul style="list-style-type: none"><li>• VDC function</li><li>• TCS function</li><li>• ABS function</li><li>• Brake limited slip differential (BLSD) function</li><li>• Brake assist function</li><li>• hill start assist function</li><li>• hill descent function</li><li>• Brake force distribution function</li><li>• Active trace control function (control of chassis control module)</li></ul>
C1115	
C1120	
C1121	
C1122	
C1123	
C1124	
C1125	
C1126	
C1127	

# ABS ACTUATOR AND ELECTRIC UNIT (CONTROL UNIT)

< ECU DIAGNOSIS INFORMATION >

[VDC/TCS/ABS]

DTC	Fail-safe condition	
C1130	The following functions are suspended:	A
C1138	<ul style="list-style-type: none"> <li>• VDC function</li> <li>• TCS function</li> <li>• Brake limited slip differential (BLSD) function</li> <li>• hill start assist function</li> <li>• Brake force distribution function</li> <li>• Active trace control function (control of chassis control module)</li> </ul>	B
C1140	<p>The following functions are suspended:</p> <ul style="list-style-type: none"> <li>• VDC function</li> <li>• TCS function</li> <li>• ABS function</li> <li>• EBD function</li> <li>• Brake limited slip differential (BLSD) function</li> <li>• Brake assist function</li> <li>• hill start assist function</li> <li>• hill descent function</li> <li>• Brake force distribution function</li> <li>• Active trace control function (control of chassis control module)</li> </ul>	C D E
C1142	<p>The following functions are suspended:</p> <ul style="list-style-type: none"> <li>• VDC function</li> <li>• TCS function</li> <li>• Brake limited slip differential (BLSD) function</li> <li>• Brake assist function</li> <li>• hill start assist function</li> <li>• Brake force distribution function</li> <li>• Active trace control function (control of chassis control module)</li> </ul>	G H
C1143	The following functions are suspended:	
C1144	<ul style="list-style-type: none"> <li>• VDC function</li> <li>• TCS function</li> <li>• Brake limited slip differential (BLSD) function</li> <li>• hill start assist function</li> <li>• hill descent function</li> <li>• Brake force distribution function</li> <li>• Active trace control function (control of chassis control module)</li> </ul>	I J
C1145	The following functions are suspended:	
C1146	<ul style="list-style-type: none"> <li>• VDC function</li> <li>• TCS function</li> <li>• ABS function</li> <li>• Brake limited slip differential (BLSD) function</li> <li>• Brake assist function</li> <li>• hill start assist function</li> <li>• hill descent function</li> <li>• Brake force distribution function</li> <li>• Active trace control function (control of chassis control module)</li> </ul>	K L M
C1155	<p>The following functions are suspended:</p> <ul style="list-style-type: none"> <li>• VDC function</li> <li>• TCS function</li> <li>• Brake limited slip differential (BLSD) function</li> <li>• Brake assist function</li> <li>• hill start assist function</li> <li>• hill descent function</li> <li>• Brake force distribution function</li> <li>• Active trace control function (control of chassis control module)</li> </ul>	N O
		P

BRC

# ABS ACTUATOR AND ELECTRIC UNIT (CONTROL UNIT)

< ECU DIAGNOSIS INFORMATION >

[VDC/TCS/ABS]

DTC	Fail-safe condition
C1160	The following functions are suspended: <ul style="list-style-type: none"> <li>• VDC function</li> <li>• TCS function</li> <li>• ABS function</li> <li>• Brake limited slip differential (BLSD) function</li> <li>• Brake assist function</li> <li>• hill start assist function</li> <li>• hill descent function</li> <li>• Brake force distribution function</li> <li>• Active trace control function (control of chassis control module)</li> </ul>
C1164	The following functions are suspended: <ul style="list-style-type: none"> <li>• VDC function</li> <li>• TCS function</li> <li>• ABS function</li> <li>• EBD function</li> <li>• Brake limited slip differential (BLSD) function</li> <li>• Brake assist function</li> <li>• hill start assist function</li> <li>• hill descent function</li> <li>• Brake force distribution function</li> <li>• Active trace control function (control of chassis control module)</li> </ul>
C1165	The following functions are suspended: <ul style="list-style-type: none"> <li>• VDC function</li> <li>• TCS function</li> <li>• ABS function</li> <li>• EBD function</li> <li>• Brake limited slip differential (BLSD) function</li> <li>• Brake assist function</li> <li>• hill start assist function</li> <li>• hill descent function</li> <li>• Brake force distribution function</li> <li>• Active trace control function (control of chassis control module)</li> </ul>
C1170	The following functions are suspended: <ul style="list-style-type: none"> <li>• VDC function</li> <li>• TCS function</li> <li>• ABS function</li> <li>• Brake limited slip differential (BLSD) function</li> <li>• Brake assist function</li> <li>• hill start assist function</li> <li>• hill descent function</li> <li>• Brake force distribution function</li> <li>• Active trace control function (control of chassis control module)</li> </ul>
C1197	Electrical vacuum assistance of brake booster is suspended.
C1198	
C1199	
C119A	Electrical vacuum assistance of brake booster is suspended.
U1000	The following functions are suspended: <ul style="list-style-type: none"> <li>• VDC function</li> <li>• TCS function</li> <li>• Brake limited slip differential (BLSD) function</li> <li>• hill start assist function</li> <li>• Brake force distribution function</li> <li>• Active trace control function (control of chassis control module)</li> </ul>

## DTC Inspection Priority Chart

INFOID:000000011280586

When multiple DTCs are displayed simultaneously, check one by one depending on the following priority list.

Priority	Detected item (DTC)
1	<ul style="list-style-type: none"> <li>• U1000 CAN COMM CIRCUIT</li> </ul>
2	<ul style="list-style-type: none"> <li>• C1170 VARIANT CODING</li> </ul>
3	<ul style="list-style-type: none"> <li>• C1130 ENGINE SIGNAL 1</li> <li>• C1144 ST ANG SEN SIGNAL</li> <li>• C1138 4WAS CIRCUIT</li> </ul>
4	<ul style="list-style-type: none"> <li>• C1109 BATTERY VOLTAGE [ABNOMAL]</li> <li>• C1111 PUMP MOTOR</li> <li>• C1140 ACTUATOR RLY</li> </ul>

# ABS ACTUATOR AND ELECTRIC UNIT (CONTROL UNIT)

< ECU DIAGNOSIS INFORMATION >

[VDC/TCS/ABS]

Priority	Detected item (DTC)
5	<ul style="list-style-type: none"> <li>• C1101 RR RH SENSOR-1</li> <li>• C1102 RR LH SENSOR-1</li> <li>• C1103 FR RH SENSOR-1</li> <li>• C1104 FR LH SENSOR-1</li> <li>• C1105 RR RH SENSOR-2</li> <li>• C1106 RR LH SENSOR-2</li> <li>• C1107 FR RH SENSOR-2</li> <li>• C1108 FR LH SENSOR-2</li> <li>• C1108 FR LH SENSOR-2</li> <li>• C1113 G SENSOR</li> <li>• C1120 FR LH IN ABS SOL</li> <li>• C1121 FR LH OUT ABS SOL</li> <li>• C1122 FR RH IN ABS SOL</li> <li>• C1123 FR RH OUT ABS SOL</li> <li>• C1124 RR LH IN ABS SOL</li> <li>• C1125 RR LH OUT ABS SOL</li> <li>• C1126 RR RH IN ABS SOL</li> <li>• C1127 RR RH OUT ABS SOL</li> <li>• C1142 PRESS SEN CIRCUIT</li> <li>• C1143 ST ANG SEN CIRCUIT</li> <li>• C1145 YAW RATE SENSOR</li> <li>• C1146 SIDE G SEN CIRCUIT</li> <li>• C1160 DECEL G SEN SET</li> <li>• C1164 CV 1</li> <li>• C1165 CV 2</li> <li>• C1197 VACUUM SENSOR</li> <li>• C1198 VACUUM SEN CIR</li> <li>• C1199 BRAKE BOOSTER</li> <li>• C119A VACUUM SEN VOLT</li> </ul>
6	<ul style="list-style-type: none"> <li>• C1155 BR FLUID LEVEL LOW</li> </ul>

A  
B  
C  
D  
E  
**BRC**  
G  
H  
I

## DTC Index

INFOID:000000011280587

DTC	Display Item	VDC warning lamp	ABS warning lamp	Brake warning lamp	Refer to
C1101	RR RH SENSOR-1	ON	ON	OFF	<a href="#">BRC-72, "DTC Logic"</a>
C1102	RR LH SENSOR-1	ON	ON	OFF	
C1103	FR RH SENSOR-1	ON	ON	OFF	
C1104	FR LH SENSOR-1	ON	ON	OFF	
C1105	RR RH SENSOR-2	ON	ON	OFF	<a href="#">BRC-76, "DTC Logic"</a>
C1106	RR LH SENSOR-2	ON	ON	OFF	
C1107	FR RH SENSOR-2	ON	ON	OFF	
C1108	FR LH SENSOR-2	ON	ON	OFF	
C1109	BATTERY VOLTAGE [ABNOMAL]	ON	ON	ON	<a href="#">BRC-78, "DTC Logic"</a>
C1111	PUMP MOTOR	ON	ON	ON	<a href="#">BRC-80, "DTC Logic"</a>
C1113	G SENSOR	ON	ON	OFF	<a href="#">BRC-82, "DTC Logic"</a>
C1115	ABS SENSOR [ABNORMAL SIGNAL]	ON	ON	OFF	<a href="#">BRC-83, "DTC Logic"</a>
C1120	FR LH IN ABS SOL	ON	ON	ON	<a href="#">BRC-85, "DTC Logic"</a>
C1121	FR LH OUT ABS SOL	ON	ON	ON	<a href="#">BRC-87, "DTC Logic"</a>
C1122	FR RH IN ABS SOL	ON	ON	ON	<a href="#">BRC-85, "DTC Logic"</a>
C1123	FR RH OUT ABS SOL	ON	ON	ON	<a href="#">BRC-87, "DTC Logic"</a>
C1124	RR LH IN ABS SOL	ON	ON	ON	<a href="#">BRC-85, "DTC Logic"</a>
C1125	RR LH OUT ABS SOL	ON	ON	ON	<a href="#">BRC-87, "DTC Logic"</a>
C1126	RR RH IN ABS SOL	ON	ON	ON	<a href="#">BRC-85, "DTC Logic"</a>

J  
K  
L  
M  
N  
O  
P

# ABS ACTUATOR AND ELECTRIC UNIT (CONTROL UNIT)

< ECU DIAGNOSIS INFORMATION >

[VDC/TCS/ABS]

DTC	Display Item	VDC warning lamp	ABS warning lamp	Brake warning lamp	Refer to
C1127	RR RH OUT ABS SOL	ON	ON	ON	<a href="#">BRC-87. "DTC Logic"</a>
C1130	ENGINE SIGNAL 1	ON	OFF	OFF	<a href="#">BRC-89. "DTC Logic"</a>
C1140	ACTUATOR RLY	ON	ON	ON	<a href="#">BRC-90. "DTC Logic"</a>
C1142	PRESS SEN CIRCUIT	ON	OFF	OFF	<a href="#">BRC-92. "DTC Logic"</a>
C1143	ST ANG SEN CIRCUIT	ON	OFF	OFF	<a href="#">BRC-94. "DTC Logic"</a>
C1144	ST ANG SEN SIGNAL	ON	OFF	OFF	<a href="#">BRC-96. "DTC Logic"</a>
C1145	YAW RATE SENSOR	ON	ON	OFF	<a href="#">BRC-82. "DTC Logic"</a>
C1146	SIDE G SEN CIRCUIT	ON	ON	OFF	
C1155	BR FLUID LEVEL LOW	ON	OFF	OFF	<a href="#">BRC-97. "DTC Logic"</a>
C1160	DECEL G SEN SET	ON	ON	OFF	<a href="#">BRC-99. "DTC Logic"</a>
C1164	CV 1	ON	ON	ON	<a href="#">BRC-100. "DTC Logic"</a>
C1165	CV 2	ON	ON	ON	
C1170	VARIANT CODING	ON	ON	OFF	<a href="#">BRC-102. "DTC Logic"</a>
C1197	VACUUM SENSOR	OFF	OFF	ON	<a href="#">BRC-103. "DTC Logic"</a>
C1198	VACUUM SEN CIR	OFF	OFF	ON	<a href="#">BRC-105. "DTC Logic"</a>
C1199	BRAKE BOOSTER	OFF	OFF	ON	<a href="#">BRC-107. "DTC Logic"</a>
C119A	VACUUM SEN VOLT	OFF	OFF	ON	<a href="#">BRC-109. "DTC Logic"</a>
U1000	CAN COMM CIRCUIT	ON	OFF	OFF	<a href="#">BRC-111. "DTC Logic"</a>

# BRAKE CONTROL SYSTEM

< WIRING DIAGRAM >

[VDC/TCS/ABS]

## WIRING DIAGRAM

### BRAKE CONTROL SYSTEM

Wiring Diagram

INFOID:000000011280588

BRAKE CONTROL SYSTEM

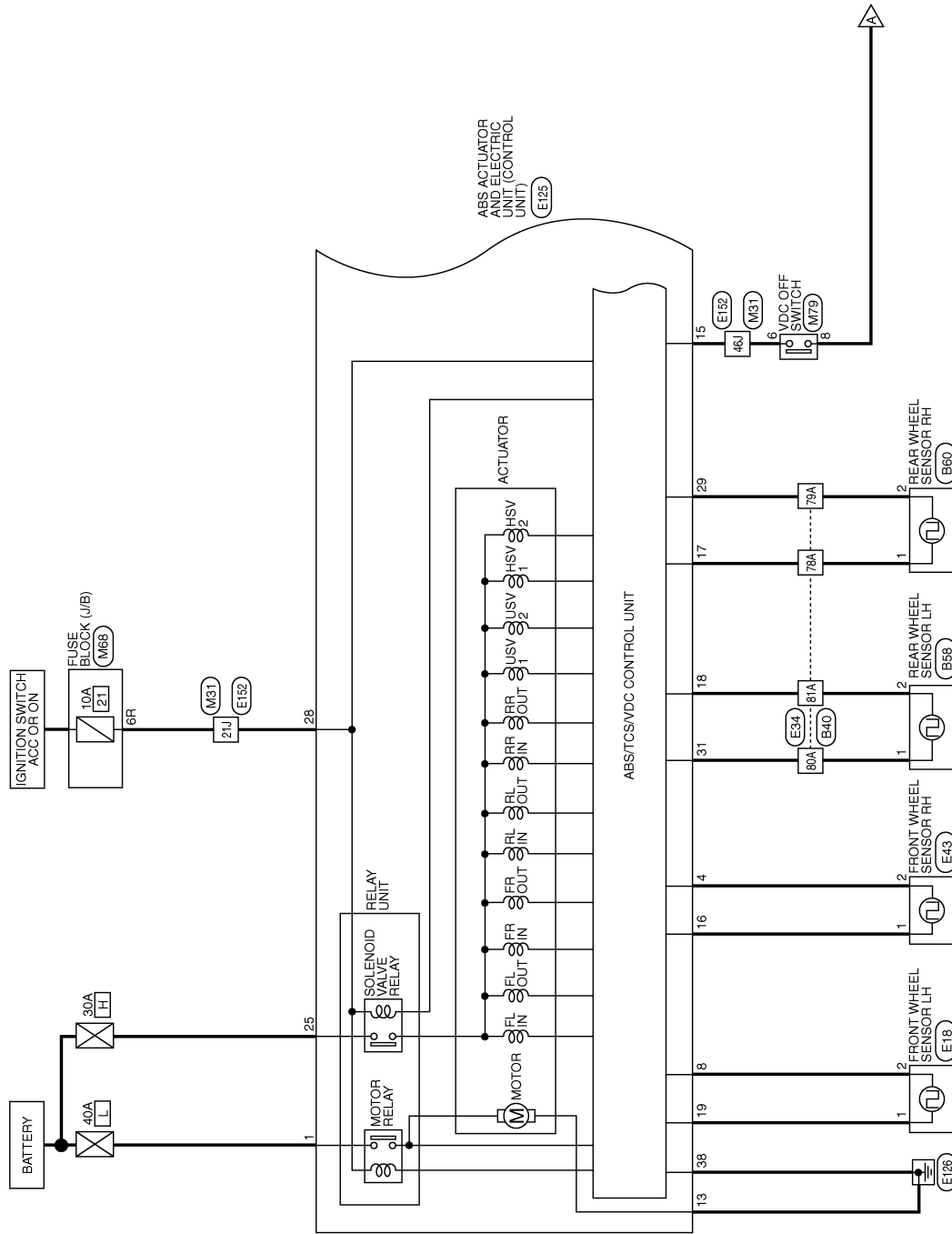

AAFWA0147GB

A  
B  
C  
D  
E  
BRC  
G  
H  
I  
J  
K  
L  
M  
N  
O  
P





# BRAKE CONTROL SYSTEM

< WIRING DIAGRAM >

[VDC/TCS/ABS]

## BRAKE CONTROL SYSTEM CONNECTORS

Connector No.	M6
Connector Name	JOINT CONNECTOR-M01
Connector Color	GRAY

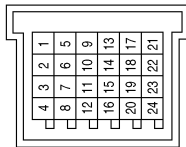

Terminal No.	Color of Wire	Signal Name
3	P	-
4	L	-
15	P	-
16	L	-
19	P	-
20	L	-

Connector No.	M9
Connector Name	WIRE TO WIRE
Connector Color	WHITE

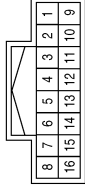

Terminal No.	Color of Wire	Signal Name
7	LA/L	-
8	B	-

Connector No.	M31
Connector Name	WIRE TO WIRE
Connector Color	WHITE

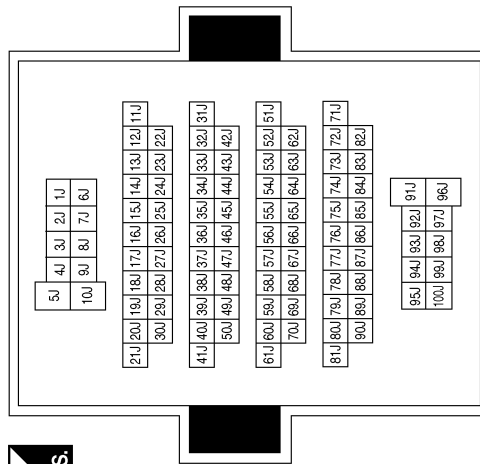

Terminal No.	Color of Wire	Signal Name
21J	LA/L	-
27J	G	-
30J	V	-
46J	BR	-
47J	LA/L	-
60J	P	-
61J	L	-

Connector No.	M43
Connector Name	JOINT CONNECTOR-M02
Connector Color	BLUE

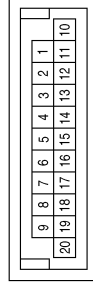

Terminal No.	Color of Wire	Signal Name
1	L	-
2	L	-
5	L	-
11	P	-
12	P	-
15	P	-

AAPFA0298GB

A  
B  
C  
D  
E  
BRC  
G  
H  
I  
J  
K  
L  
M  
N  
O  
P

# BRAKE CONTROL SYSTEM

< WIRING DIAGRAM >

[VDC/TCS/ABS]

Connector No.	M67
Connector Name	JOINT CONNECTOR-M27
Connector Color	WHITE



Terminal No.	Color of Wire	Signal Name
1	B	-
5	B	-
6	B	-

Connector No.	M56
Connector Name	STEERING ANGLE SENSOR
Connector Color	GRAY



Terminal No.	Color of Wire	Signal Name
1	B	-
2	P	-
4	G	-
5	L	-

Connector No.	M44
Connector Name	FUSE BLOCK (J/B)
Connector Color	WHITE

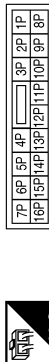

Terminal No.	Color of Wire	Signal Name
7P	Y	-
13P	LA/G	-

Connector No.	M77
Connector Name	COMBINATION METER
Connector Color	WHITE

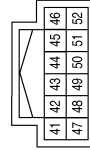

Terminal No.	Color of Wire	Signal Name
41	L	CAN-H
42	P	CAN-L
45	LA/G	BAT
52	B	G1

Connector No.	M76
Connector Name	COMBINATION METER
Connector Color	WHITE

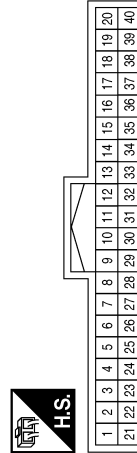

Terminal No.	Color of Wire	Signal Name
1	B	GND
25	V	BRAKE OIL SW
26	G	PKB SW

Connector No.	M68
Connector Name	FUSE BLOCK (J/B)
Connector Color	BROWN

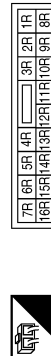

Terminal No.	Color of Wire	Signal Name
6R	LA/L	-

AAPFA0299GB

# BRAKE CONTROL SYSTEM

< WIRING DIAGRAM >

[VDC/TCS/ABS]

Connector No.	M251
Connector Name	WIRE TO WIRE
Connector Color	WHITE

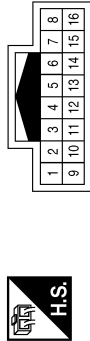

Terminal No.	Color of Wire	Signal Name
7	L	-
8	B	-

Connector No.	M96
Connector Name	CHASSIS CONTROL MODULE
Connector Color	WHITE

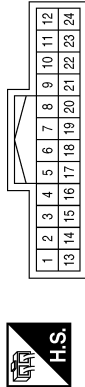

Terminal No.	Color of Wire	Signal Name
3	P	CAN-L
4	L	CAN-H

Connector No.	M79
Connector Name	VDC OFF SWITCH
Connector Color	BLACK

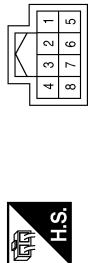

Terminal No.	Color of Wire	Signal Name
6	BR	-
8	B	-

Connector No.	E18
Connector Name	FRONT WHEEL SENSOR LH
Connector Color	GRAY



Terminal No.	Color of Wire	Signal Name
1	W	-
2	P	-

Connector No.	E16
Connector Name	ECM
Connector Color	BLACK

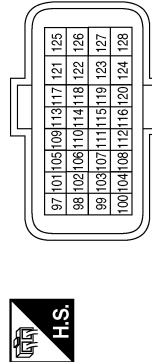

Terminal No.	Color of Wire	Signal Name
99	P	CAN-L
100	L	CAN-H
115	V	STOP LAMP SWITCH

Connector No.	M254
Connector Name	HILL DESCENT CONTROL SWITCH
Connector Color	GRAY



Terminal No.	Color of Wire	Signal Name
6	B	-
9	L	-

AAPIA0300GB

A  
B  
C  
D  
E  
BRC  
G  
H  
I  
J  
K  
L  
M  
N  
O  
P

# BRAKE CONTROL SYSTEM

< WIRING DIAGRAM >

[VDC/TCS/ABS]

Terminal No.	Color of Wire	Signal Name
78A	Y	-
79A	LG	-
80A	BR	-
81A	G	-

Connector No.	E34
Connector Name	WIRE TO WIRE
Connector Color	GRAY

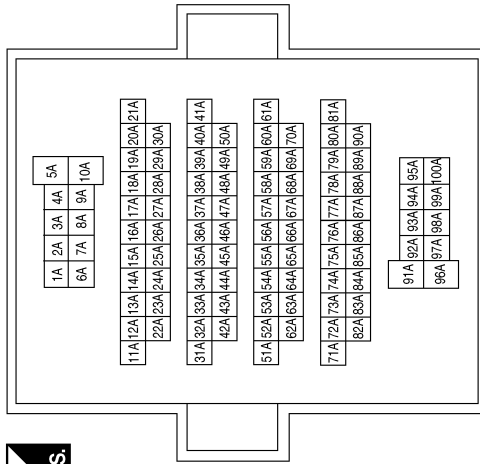

Connector No.	E28
Connector Name	FUSE BLOCK (J/B)
Connector Color	WHITE

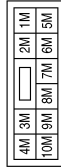

Terminal No.	Color of Wire	Signal Name
5M	V	-

Connector No.	E43
Connector Name	FRONT WHEEL SENSOR RH
Connector Color	GRAY



Connector No.	E38
Connector Name	STOP LAMP SWITCH
Connector Color	WHITE



Terminal No.	Color of Wire	Signal Name
1	R	-
2	SB	-

Terminal No.	Color of Wire	Signal Name
1	V	-
2	LG	-

AAFIA0303GB

# BRAKE CONTROL SYSTEM

< WIRING DIAGRAM >

[VDC/TCS/ABS]

Connector No.	E52
Connector Name	PARKING BRAKE SWITCH
Connector Color	BLACK



Terminal No.	Color of Wire	Signal Name
1	G	-

Terminal No.	Color of Wire	Signal Name
1	L	-
2	P	-
5	L	-
6	P	-
13	L	-
14	P	-
17	L	-
18	P	-
19	V	-
23	LG	-

Connector No.	E44
Connector Name	JOINT CONNECTOR-E01
Connector Color	WHITE

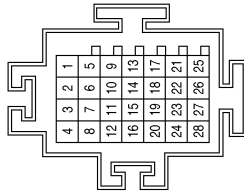

Connector No.	E120
Connector Name	IPDM E/R (INTELLIGENT POWER DISTRIBUTION MODULE ENGINE ROOM)
Connector Color	GRAY

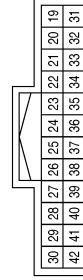

Terminal No.	Color of Wire	Signal Name
39	L	CABIN MOTOR 1
40	P	CABIN MOTOR 2

Connector No.	E63
Connector Name	BRAKE FLUID LEVEL SWITCH
Connector Color	BLACK



Terminal No.	Color of Wire	Signal Name
1	V	-
2	BR	-

AAPFA0301GB

A  
B  
C  
D  
E  
**BRC**  
G  
H  
I  
J  
K  
L  
M  
N  
O  
P

# BRAKE CONTROL SYSTEM

< WIRING DIAGRAM >

[VDC/TCS/ABS]

Connector No.	E152
Connector Name	WIRE TO WIRE
Connector Color	WHITE

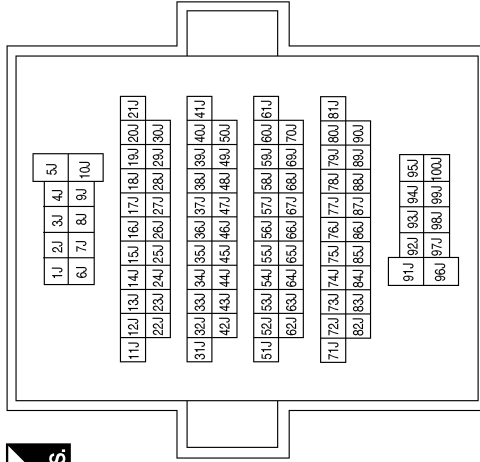

Terminal No.	Color of Wire	Signal Name
21J	GR	-
27J	G	-
30J	V	-
46J	BR	-
47J	Y	-
60J	P	-
61J	L	-

Terminal No.	Color of Wire	Signal Name
15	BR	VDC OFF
16	R	WSP FR
17	Y	WSP RR
18	G	WSS RL
19	W	WSP FL
20	-	-
21	-	-
22	-	-
23	-	-
24	SHIELD	GND EXT
25	BR	UB VR
26	L	CAN-H
27	-	-
28	GR	WAU
29	LG	WSS RR
30	-	-
31	BR	WSP RL
32	-	-
33	-	-
34	-	-
35	-	-
36	-	-
37	-	-
38	B	GND ECU

Connector No.	E125
Connector Name	ABS ACTUATOR AND ELECTRIC UNIT (CONTROL UNIT)
Connector Color	BLACK

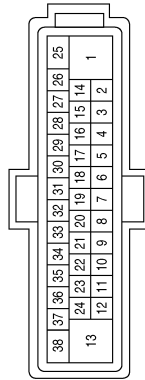

Terminal No.	Color of Wire	Signal Name
1	Y	UB MR
2	-	-
3	-	-
4	SB	WSS FR
5	V	U5V EXT
6	-	-
7	-	-
8	P	WSS FL
9	Y	HDC
10	-	-
11	-	-
12	LG	VAC
13	B	GND MR
14	P	CAN-L

AAPIA0302GB

# BRAKE CONTROL SYSTEM

< WIRING DIAGRAM >

[VDC/TCS/ABS]

Connector No.	E167
Connector Name	VACUUM SENSOR
Connector Color	BLACK



Terminal No.	Color of Wire	Signal Name
1	LG	-
2	SHIELD	-
3	V	-

Connector No.	B40
Connector Name	WIRE TO WIRE
Connector Color	GRAY

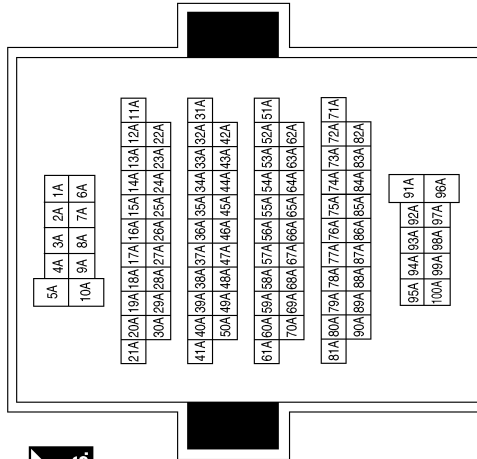

Terminal No.	Color of Wire	Signal Name
78A	BG	-
79A	Y	-
80A	BR	-
81A	R	-

Connector No.	F42
Connector Name	IPDM E/R (INTELLIGENT POWER DISTRIBUTION MODULE ENGINE ROOM)
Connector Color	BLACK

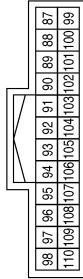

Terminal No.	Color of Wire	Signal Name
87	L	MOTOR CABIN 1
88	P	MOTOR CABIN 2

Connector No.	B58
Connector Name	REAR WHEEL SENSOR LH
Connector Color	BLACK



Terminal No.	Color of Wire	Signal Name
1	BR	-
2	R	-

Connector No.	F75
Connector Name	TCM (TRANSMISSION CONTROL MODULE)
Connector Color	BLACK

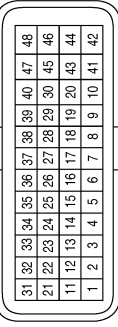

Terminal No.	Color of Wire	Signal Name
23	P	CAN-L
33	L	CAN-H

Connector No.	B60
Connector Name	REAR WHEEL SENSOR RH
Connector Color	BLACK



Terminal No.	Color of Wire	Signal Name
1	BG	-
2	Y	-

A  
B  
C  
D  
E  
BRC  
G  
H  
I  
J  
K  
L  
M  
N  
O  
P

# BASIC INSPECTION

## DIAGNOSIS AND REPAIR WORK FLOW

### Work Flow

INFOID:000000011280589

#### DETAILED FLOW

### 1. INTERVIEW FROM THE CUSTOMER

Clarify customer complaints before inspection. First of all, perform an interview utilizing [BRC-65, "Diagnostic Work Sheet"](#) and reproduce the symptom as well as fully understand it. Ask customer about his/her complaints carefully. Check symptoms by driving vehicle with customer, if necessary.

**CAUTION:**

**Customers are not professional. Never guess easily like "maybe the customer means that..." or "maybe the customer mentions this symptom".**

&gt;&gt; GO TO 2.

### 2. CHECK SYMPTOM

Reproduce the symptom that is indicated by the customer, based on the information from the customer obtained by interview. Also check that the symptom is not caused by fail-safe mode. Refer to [BRC-49, "Fail-Safe"](#).

**CAUTION:**

**When the symptom is caused by normal operation, fully inspect each portion and obtain the understanding of customer that the symptom is not caused by a malfunction.**

&gt;&gt; GO TO 3.

### 3. PERFORM THE SELF DIAGNOSTIC

Ⓟ With CONSULT

1. Turn the ignition switch OFF → ON.

**CAUTION:**

**Be sure to wait of 10 seconds after turning ignition switch OFF or ON.**

2. Repeat step 1 two or more times.
3. Perform "Self Diagnostic Result" of "ABS".

Is DTC detected?

- YES >> Record or print "Self Diagnostic Result" and freeze frame data (FFD). GO TO 4.  
NO >> GO TO 6.

### 4. RECHECK THE SYMPTOM

Ⓟ With CONSULT

1. Erase "Self Diagnostic Result" of "ABS".
2. Turn the ignition switch OFF → ON → OFF.

**CAUTION:**

**Be sure to wait of 10 seconds after turning ignition switch OFF or ON.**

3. Perform DTC confirmation procedures for the error-detected system.

**NOTE:**

If some DTCs are detected at the same time, determine the order for performing the diagnosis based on [BRC-52, "DTC Inspection Priority Chart"](#).

Is any DTC detected?

- YES >> GO TO 5.  
NO >> Check harness and connectors based on the information obtained by interview. Refer to [GI-44, "Intermittent Incident"](#).

### 5. REPAIR OR REPLACE ERROR-DETECTED PART

1. Repair or replace error-detected parts.
2. Reconnect part or connector after repairing or replacing.
3. When DTC is detected, erase "Self Diagnostic Result" of "ABS".



# DIAGNOSIS AND REPAIR WORK FLOW

< BASIC INSPECTION >

[VDC/TCS/ABS]

**CAUTION:**

- Turn the ignition switch OFF → ON → OFF after erase self diagnostic result.
- Be sure to wait of 10 seconds after turning ignition switch OFF or ON.

>> GO TO 7.

## 6. IDENTIFY ERROR-DETECTED SYSTEM BY SYMPTOM DIAGNOSIS

Estimate error-detected system based on symptom diagnosis and perform inspection.

Can the error-detected system be identified?

YES >> GO TO 7.

NO >> Check harness and connectors based on the information obtained by interview. Refer to [GI-44](#).  
"Intermittent Incident".

## 7. FINAL CHECK

With CONSULT

1. Check the reference value for "ABS".
2. Recheck the symptom and check that the symptom is not reproduced on the same conditions.

Is the symptom reproduced?

YES >> GO TO 3.

NO >> Inspection End.

## Diagnostic Work Sheet

INFOID:0000000011280590

### Description

- In general, customers have their own criteria for a problem. Therefore, it is important to understand the symptom and status well enough by asking the customer about his/her concerns carefully. To systemize all the information for the diagnosis, prepare the interview sheet referring to the interview points.
- In some cases, multiple conditions that appear simultaneously may cause a DTC to be detected.

### INTERVIEW SHEET SAMPLE

Interview sheet					
Customer name		MR/MS	Registration number	Initial year registration	
			Vehicle type	VIN	
Storage date			Engine	Mileage	km (Mile)
Symptom	<input type="checkbox"/> Does not operate ( ) function				
	<input type="checkbox"/> Warning lamp for ( ) turns ON.				
	<input type="checkbox"/> Noise		<input type="checkbox"/> Vibration		
	<input type="checkbox"/> Other ( )				
First occurrence	<input type="checkbox"/> Recently <input type="checkbox"/> Other ( )				
Frequency of occurrence	<input type="checkbox"/> Always <input type="checkbox"/> Under a certain conditions of <input type="checkbox"/> Sometimes ( time(s)/day)				
Climate conditions	<input type="checkbox"/> Irrelevant				
	Weather	<input type="checkbox"/> Fine <input type="checkbox"/> Cloud <input type="checkbox"/> Rain <input type="checkbox"/> Snow <input type="checkbox"/> Others ( )			
	Temperature	<input type="checkbox"/> Hot <input type="checkbox"/> Warm <input type="checkbox"/> Cool <input type="checkbox"/> Cold <input type="checkbox"/> Temperature [Approx. °C (°F)]			
	Relative humidity <input type="checkbox"/> High <input type="checkbox"/> Moderate <input type="checkbox"/> Low				
Road conditions	<input type="checkbox"/> Urban area <input type="checkbox"/> Suburb area <input type="checkbox"/> Highway <input type="checkbox"/> Mountainous road (uphill or downhill) <input type="checkbox"/> Rough road				
Operating condition, etc.	<input type="checkbox"/> Irrelevant <input type="checkbox"/> When engine starts <input type="checkbox"/> During idling <input type="checkbox"/> During driving <input type="checkbox"/> During acceleration <input type="checkbox"/> At constant speed driving <input type="checkbox"/> During deceleration <input type="checkbox"/> During cornering (right curve or left curve) <input type="checkbox"/> When steering wheel is steered (to right or to left)				

# DIAGNOSIS AND REPAIR WORK FLOW

< BASIC INSPECTION >

[VDC/TCS/ABS]

## Interview sheet

Customer name	MR/MS	Registration number		Initial year registration	
		Vehicle type		VIN	
Storage date		Engine		Mileage	km (Mile)
Other conditions					

Memo

# ADDITIONAL SERVICE WHEN REPLACING ABS ACTUATOR AND ELECTRIC UNIT (CONTROL UNIT)

< BASIC INSPECTION >

[VDC/TCS/ABS]

## ADDITIONAL SERVICE WHEN REPLACING ABS ACTUATOR AND ELECTRIC UNIT (CONTROL UNIT)

### Description

INFOID:0000000011280591

- When replaced the ABS actuator and electric unit (control unit), perform adjust the neutral position of steering angle sensor. Refer to [BRC-70. "Work Procedure"](#).
- When replaced the ABS actuator and electric unit (control unit), perform calibration of the decel G sensor. Refer to [BRC-70. "Work Procedure"](#).

A  
B  
C  
D  
E  
G  
H  
I  
J  
K  
L  
M  
N  
O  
P

**BRC**

# ADJUSTMENT OF STEERING ANGLE SENSOR NEUTRAL POSITION

< BASIC INSPECTION >

[VDC/TCS/ABS]

## ADJUSTMENT OF STEERING ANGLE SENSOR NEUTRAL POSITION

### Description

INFOID:000000011280592

Refer to the table below to determine if adjustment of steering angle sensor neutral position is required.

×: Required –: Not required

Situation	Adjustment of steering angle sensor neutral position
Removing/Installing ABS actuator and electric unit (control unit)	—
Replacing ABS actuator and electric unit (control unit)	×
Removing/Installing steering angle sensor	×
Replacing steering angle sensor	×
Removing/Installing steering components	×
Replacing steering components	×
Removing/Installing suspension components	×
Replacing suspension components	×
Change tires to new ones	—
Tire rotation	—
Adjusting wheel alignment	×

### Work Procedure

INFOID:000000011280593

#### ADJUSTMENT OF STEERING ANGLE SENSOR NEUTRAL POSITION

##### **CAUTION:**

**To adjust neutral position of steering angle sensor, make sure to use CONSULT. (Adjustment cannot be done without CONSULT).**

#### 1. ALIGN THE VEHICLE STATUS

Stop vehicle with front wheels in straight-ahead position.

>> GO TO 2.

#### 2. PERFORM THE NEUTRAL POSITION ADJUSTMENT FOR THE STEERING ANGLE SENSOR

1. On the CONSULT screen, touch “Work support” and “ST ANGLE SENSOR ADJUSTMENT” in order.
2. Touch “Start”.

##### **CAUTION:**

**Do not touch steering wheel while adjusting steering angle sensor.**

3. After approximately 10 seconds, touch “End”.

##### **NOTE:**

After approximately 60 seconds, it ends automatically.

4. Turn ignition switch OFF, then turn it ON again.

##### **CAUTION:**

**Be sure to perform above operation.**

>> GO TO 3.

#### 3. CHECK DATA MONITOR

1. Run vehicle with front wheels in straight-ahead position, then stop.
2. Select “Data Monitor”. Then make sure “STR ANGLE SIG” is within  $0 \pm 3.5^\circ$ .

Is the steering angle within the specified range?

YES >> GO TO 4.

NO >> Perform the neutral position adjustment for the steering angle sensor again, GO TO 1.

#### 4. ERASE THE SELF-DIAGNOSIS MEMORY

Erase the “Self Diagnostic Result” memory of the ABS actuator and electric unit (control unit) and ECM.

- ABS actuator and electric unit (control unit): Refer to [BRC-42, "CONSULT Function"](#).

# ADJUSTMENT OF STEERING ANGLE SENSOR NEUTRAL POSITION

< BASIC INSPECTION >

[VDC/TCS/ABS]

- ECM: Refer to [EC-69. "CONSULT Function"](#).

Are the memories erased?

YES >> Inspection End.

NO >> Check the items indicated by the "Self Diagnostic Result".

A

B

C

D

E

**BRC**

G

H

I

J

K

L

M

N

O

P

# CALIBRATION OF DECEL G SENSOR

< BASIC INSPECTION >

[VDC/TCS/ABS]

## CALIBRATION OF DECEL G SENSOR

### Description

INFOID:000000011280594

#### CAUTION:

Always perform the decel G sensor calibration before driving when the following operation is performed.

#### NOTE:

Yaw rate/side/decel G sensor calibration is performed when performing the decel G sensor calibration.

×: Required —: Not required

Procedure	Decel G sensor calibration
Removing/ installing ABS actuator and electric unit (control unit)	—
Replacing ABS actuator and electric unit (control unit)	×
Removing/installing steering components	—
Replacing steering components	—
Removing/installing suspension components	—
Replacing suspension components	—
Removing/installing tire	—
Replacing tire	—
Tire rotation	—
Adjusting wheel alignment.	—

### Work Procedure

INFOID:000000011280595

#### Decel G sensor calibration

#### CAUTION:

Always use CONSULT for the decel G sensor calibration. (It cannot be adjusted other than with CONSULT.)

#### NOTE:

Yaw rate/side/decel G sensor calibration is performed when performing the decel G sensor calibration.

#### 1. CHECK THE VEHICLE STATUS

1. Steer the steering wheel to the straight-ahead position. Stop the vehicle on level surface.
2. Stop the engine.
3. Turn the ignition switch OFF.

Is the vehicle stopped in the straight-ahead position on level surface?

YES >> GO TO 2.

NO >> Steer the steering wheel to the straight-ahead position. Stop the vehicle on level surface.

#### 2. PERFORM DECEL G SENSOR CALIBRATION

#### CAUTION:

- Never allow passenger or load on the vehicle.
- Never apply vibration to the vehicle body when opening or closing door during calibration.

Ⓜ With CONSULT

1. Turn the ignition switch ON.

#### CAUTION:

Never start engine.

2. Select "ABS", "Work support", "DECEL G SEN CALIBRATION" in this order.
3. Select "Start".
4. After approx. 10 seconds, select "End".
5. Turn ignition switch OFF and then turn it ON again.

#### CAUTION:

Be sure to perform the operation above.

>> GO TO 3.

# CALIBRATION OF DECEL G SENSOR

< BASIC INSPECTION >

[VDC/TCS/ABS]

## 3. CHECK DATA MONITOR

④ With CONSULT

1. Drive the vehicle. Steer the steering wheel to the straight-ahead position. Stop the vehicle on level surface.
2. Select “ABS”, “Data Monitor”, “ECU INPUT SIGNALS” and “DECEL G SENSOR” in this order. Check that the signal is within the specified value.

**DECEL G SENSOR : Approx. ± 0.01 G**

Is the inspection result normal?

YES >> GO TO 4.

NO >> GO TO 1.

## 4. ERASE SELF DIAGNOSTIC MEMORY

④ With CONSULT

Erase “Self Diagnosis Result” of “ABS”.

Are the memories erased?

YES >> Inspection End.

NO >> Check the items indicated by the “Self Diagnostic Result”.

A  
B  
C  
D  
E  
G  
H  
I  
J  
K  
L  
M  
N  
O  
P

BRC

# C1101, C1102, C1103, C1104 WHEEL SENSOR

< DTC/CIRCUIT DIAGNOSIS >

[VDC/TCS/ABS]

## DTC/CIRCUIT DIAGNOSIS

### C1101, C1102, C1103, C1104 WHEEL SENSOR

#### DTC Logic

INFOID:000000011280596

#### DTC DETECTION LOGIC

DTC	Display Item	Malfunction detected condition	Possible causes
C1101	RR RH SENSOR-1	<ul style="list-style-type: none"><li>When power supply voltage of rear wheel sensor RH is low.</li><li>When an open or shorted circuit is detected in rear wheel sensor RH circuit.</li></ul>	<ul style="list-style-type: none"><li>Harness or connector</li><li>Wheel sensor</li><li>ABS actuator and electric unit (control unit)</li></ul>
C1102	RR LH SENSOR-1	<ul style="list-style-type: none"><li>When power supply voltage of rear wheel sensor LH is low.</li><li>When an open or shorted circuit is detected in rear wheel sensor LH circuit.</li></ul>	
C1103	FR RH SENSOR-1	<ul style="list-style-type: none"><li>When power supply voltage of front wheel sensor RH is low.</li><li>When an open or shorted circuit is detected in front wheel sensor RH circuit.</li></ul>	
C1104	FR LH SENSOR-1	<ul style="list-style-type: none"><li>When power supply voltage of front wheel sensor LH is low.</li><li>When an open or shorted circuit is detected in front wheel sensor LH circuit.</li></ul>	

#### DTC CONFIRMATION PROCEDURE

##### 1. CHECK SELF DIAGNOSTIC RESULT

Ⓜ With CONSULT.

- Start engine and drive vehicle at approximately 21 km/h (13 MPH) or more for approximately 5 minutes.
- Perform "Self Diagnostic Result".

Is DTC C1101, C1102, C1103 or C1104 detected?

- YES >> Proceed to diagnosis procedure. Refer to [BRC-72, "Diagnosis Procedure"](#).  
NO >> Inspection End.

#### Diagnosis Procedure

INFOID:000000011280597

Regarding Wiring Diagram information, refer to [BRC-55, "Wiring Diagram"](#).

##### 1. CONFIRM DTC

Ⓜ With CONSULT

- Perform "Self Diagnostic Result" of "ABS" and record all active DTCs.
- Clear all DTCs.
- Perform DTC confirmation procedure. Refer to [BRC-72, "DTC Logic"](#).

Does DTC C1101, C1102, C1103 or C1104 reset?

- YES >> GO TO 2.  
NO >> Refer to [GI-44, "Intermittent Incident"](#).

##### 2. INSPECT WHEEL SENSOR

Inspect the suspect wheel sensor for damage or deformation.

Is the inspection result normal?

- YES >> GO TO 3.  
NO >> Repair or replace as necessary.

##### 3. HARNESS AND CONNECTOR INSPECTION



# C1101, C1102, C1103, C1104 WHEEL SENSOR

[VDC/TCS/ABS]

## < DTC/CIRCUIT DIAGNOSIS >

1. Disconnect ABS actuator and electric unit (control unit) connector E125 and wheel sensor connector of suspect wheel.
2. Check harness, connectors and terminals for corrosion, deformation, disconnection, looseness or damage.

Is the inspection result normal?

- YES >> GO TO 4.  
 NO >> Repair or replace as necessary.

### 4. CHECK WHEEL SENSOR OUTPUT SIGNAL

1. Connect ABS active wheel sensor tester (J-45741) to wheel sensor using appropriate adapter.
2. Turn on the ABS active wheel sensor tester power switch.

**NOTE:**

The green POWER indicator should illuminate. If the POWER indicator does not illuminate, replace the battery in the ABS active wheel sensor tester before proceeding.

3. Spin the wheel of the vehicle by hand and observe the red SENSOR indicator on the ABS active wheel sensor tester. The red SENSOR indicator should flash ON and OFF to indicate an output signal.

**NOTE:**

If the red SENSOR indicator illuminates but does not flash, reverse the polarity of the tester leads and retest.

Does the ABS active wheel sensor tester detect a signal?

- YES >> GO TO 5.  
 NO >> Replace the wheel sensor. Refer to [BRC-130, "FRONT WHEEL SENSOR : Removal and Installation"](#) or [BRC-132, "REAR WHEEL SENSOR : Removal and Installation"](#).

### 5. CHECK WIRING HARNESS FOR SHORT TO VOLTAGE

1. Turn ignition switch ON.
2. Check voltage between wheel sensor harness connector terminals of suspect wheel and ground.

Wheel Sensor			Ground	Voltage
Wheel	Connector	Terminal		
Front LH	E18	1	—	0V
		2		
Front RH	E43	1		
		2		
Rear LH	B58	1		
		2		
Rear RH	B60	1		
		2		

Is the inspection result normal?

- YES >> GO TO 6.  
 NO >> Repair the circuit.

### 6. CHECK WIRING HARNESS FOR SHORT TO GROUND

1. Turn ignition switch OFF.
2. Check continuity between wheel sensor harness connector terminals of suspect wheel and ground.

Wheel Sensor			Ground	Continuity
Wheel	Connector	Terminal		

# C1101, C1102, C1103, C1104 WHEEL SENSOR

< DTC/CIRCUIT DIAGNOSIS >

[VDC/TCS/ABS]

Wheel	Connector	Terminal	Continuity	Result
Front LH	E18	1	—	No
		2		
Front RH	E43	1		
		2		
Rear LH	B58	1		
		2		
Rear RH	B60	1		
		2		

**Is the inspection result normal?**

YES >> GO TO 7.

NO >> Repair the circuit.

## 7. CHECK WIRING HARNESS FOR SHORT BETWEEN CIRCUITS

Check continuity between wheel sensor harness connector terminals of suspect wheel.

Wheel Sensor		(+)	(-)	Continuity
Wheel	Connector	Terminal	Terminal	
Front LH	E18	1	2	No
Front RH	E43			
Rear LH	B58			
Rear RH	B60			

**Is the inspection result normal?**

YES >> GO TO 8.

NO >> Repair the circuit.

## 8. CHECK WIRING HARNESS FOR OPEN CIRCUIT

Check continuity between ABS actuator and electric unit (control unit) harness connector E125 and harness connector of suspect wheel sensor.

Wheel sensor	ABS actuator and electric unit (control unit)		Wheel sensor		Continuity
	Connector	Terminal	Connector	Terminal	
Front LH	E125	19	E18	1	Yes
		8		2	
Front RH		16	E43	1	
		4		2	
Rear LH		31	B58	1	
		18		2	
Rear RH		17	B60	1	
		29		2	

**Is the inspection result normal?**

YES >> GO TO 9.

NO >> Repair the circuit.

## 9. CHECK ABS ACTUATOR AND ELECTRIC UNIT (CONTROL UNIT) POWER SUPPLY CIRCUIT

1. Turn ignition switch ON.
2. Check voltage between ABS actuator and electric unit (control unit) harness connector E125 terminal and ground.

# C1101, C1102, C1103, C1104 WHEEL SENSOR

< DTC/CIRCUIT DIAGNOSIS >

[VDC/TCS/ABS]

ABS actuator and electric unit (control unit)		Ground	Condition	Voltage (Approx.)
Connector	Terminal			
E125	28	—	Ignition switch ON	Battery voltage
			Ignition switch OFF	0V

Is the inspection result normal?

YES >> GO TO 10.

NO >> Check the following:

- 10A fuse No. 21 located in the FUSE BLOCK (J/B)
- Harness between ABS actuator and electric unit (control unit) and IPDM E/R

## 10. CHECK ABS ACTUATOR AND ELECTRIC UNIT (CONTROL UNIT) GROUND CIRCUIT

1. Turn ignition switch OFF.
2. Check continuity between ABS actuator and electric unit (control unit) connector E125 terminals and ground.

ABS actuator and electric unit (control unit)		—	Continuity
Connector	Terminal		
E125	13	Ground	Yes
	38		

Is the inspection result normal?

YES >> GO TO 11.

NO >> Repair or replace malfunctioning components.

## 11. CHECK WHEEL SENSOR INPUT VOLTAGE

1. Connect ABS actuator and electric unit (control unit) connector E125.
2. Turn ignition switch ON.
3. Check voltage between suspect wheel sensor harness connector terminals.

Wheel Sensor		(+)	(-)	Voltage (Approx.)
Wheel	Connector	Terminal	Terminal	
Front LH	E18	1	2	Battery voltage
Front RH	E43			
Rear LH	B58			
Rear RH	B60			

Is the inspection result normal?

YES >> Replace wheel sensor. Refer to [BRC-130, "FRONT WHEEL SENSOR : Removal and Installation"](#) or [BRC-132, "REAR WHEEL SENSOR : Removal and Installation"](#). Then, GO TO 12.

NO >> Replace ABS actuator and electric unit (control unit). Refer to [BRC-134, "Removal and Installation"](#).

## 12. CONFIRM REPAIR

Ⓜ With CONSULT

1. Clear all DTCs.
2. Perform DTC confirmation procedure. Refer to [BRC-72, "DTC Logic"](#).

Does DTC C1101, C1102, C1103 or C1104 reset?

YES >> Replace ABS actuator and electric unit (control unit). Refer to [BRC-134, "Removal and Installation"](#).

NO >> Inspection End.

# C1105, C1106, C1107, C1108 WHEEL SENSOR

< DTC/CIRCUIT DIAGNOSIS >

[VDC/TCS/ABS]

## C1105, C1106, C1107, C1108 WHEEL SENSOR

### DTC Logic

INFOID:000000011280598

#### DTC DETECTION LOGIC

DTC	Display Item	Malfunction detected condition	Possible causes
C1105	RR RH SENSOR-2	<ul style="list-style-type: none"><li>When distance between rear wheel sensor RH and rear wheel sensor RH rotor is large.</li><li>When installation of rear wheel sensor RH or rear wheel sensor RH rotor is not normal.</li></ul>	<ul style="list-style-type: none"><li>Wheel sensor</li><li>ABS actuator and electric unit (control unit)</li><li>Sensor rotor</li></ul>
C1106	RR LH SENSOR-2	<ul style="list-style-type: none"><li>When distance between rear wheel sensor LH and rear wheel sensor LH rotor is large.</li><li>When installation of rear wheel sensor LH or rear wheel sensor LH rotor is not normal.</li></ul>	
C1107	FR RH SENSOR-2	<ul style="list-style-type: none"><li>When distance between front wheel sensor RH and front wheel sensor RH rotor is large.</li><li>When installation of front wheel sensor RH or front wheel sensor RH rotor is not normal.</li></ul>	
C1108	FR LH SENSOR-2	<ul style="list-style-type: none"><li>When distance between front wheel sensor LH and front wheel sensor LH rotor is large.</li><li>When installation of front wheel sensor LH or front wheel sensor LH rotor is not normal.</li></ul>	

#### DTC CONFIRMATION PROCEDURE

##### 1. CHECK SELF-DIAGNOSTIC RESULT

Ⓜ With CONSULT.

- Start engine and drive vehicle at approximately 21 km/h (13 MPH) or more for approximately 5 minutes.
- Perform "Self Diagnostic Result".

Is DTC C1105, C1106, C1107 or C1108 detected?

YES >> Proceed to diagnosis procedure. Refer to [BRC-76, "Diagnosis Procedure"](#).

NO >> Inspection End.

#### Diagnosis Procedure

INFOID:000000011280599

Regarding Wiring Diagram information, refer to [BRC-55, "Wiring Diagram"](#).

##### 1. CONFIRM DTC

Ⓜ With CONSULT

- Perform "Self Diagnostic Result" of "ABS" and record all active DTCs.
- Clear all DTCs.
- Perform DTC confirmation procedure. Refer to [BRC-72, "DTC Logic"](#).

Does DTC C1105, C1106, C1107 or C1108 reset?

YES >> GO TO 2.

NO >> Refer to [GI-44, "Intermittent Incident"](#).

##### 2. CHECK TIRE PRESSURE AND TIRE WEAR

Check tires for excessive wear and proper inflation. Refer to [WT-64, "Adjustment"](#).

Is the inspection result normal?

YES >> GO TO 3.

NO >> Repair or replace as necessary.

##### 3. CHECK WHEEL SENSOR

Check wheel sensor for the following:

- Proper installation

# C1105, C1106, C1107, C1108 WHEEL SENSOR

[VDC/TCS/ABS]

## < DTC/CIRCUIT DIAGNOSIS >

- Physical damage
- Contamination

Is the inspection result normal?

YES >> GO TO 4.

NO >> Repair or replace as necessary.

### 4.CHECK SENSOR ROTOR

Check sensor rotor for the following:

- Contamination
- Physical damage (missing teeth, cracks, etc.)
- Foreign material
- Looseness

Is the inspection result normal?

YES >> Replace the wheel sensor. Refer to [BRC-130. "FRONT WHEEL SENSOR : Removal and Installation"](#) or [BRC-132. "REAR WHEEL SENSOR : Removal and Installation"](#). Then, GO TO 5.

NO >> Repair or replace as necessary.

### 5.CONFIRM REPAIR

Ⓜ With CONSULT

1. Clear all DTCs.
2. Perform DTC confirmation procedure. Refer to [BRC-76. "DTC Logic"](#).

Does DTC C1105, C1106, C1107 or C1108 reset?

YES >> Replace ABS actuator and electric unit (control unit). Refer to [BRC-134. "Removal and Installation"](#).

NO >> Inspection End.

A  
B  
C  
D  
E  
BRC  
G  
H  
I  
J  
K  
L  
M  
N  
O  
P

# C1109 POWER AND GROUND SYSTEM

< DTC/CIRCUIT DIAGNOSIS >

[VDC/TCS/ABS]

## C1109 POWER AND GROUND SYSTEM

### DTC Logic

INFOID:000000011280600

#### DTC DETECTION LOGIC

DTC	Display Item	Malfunction detected condition	Possible causes
C1109	BATTERY VOLTAGE [ABNORMAL]	<ul style="list-style-type: none"> <li>• When ignition voltage is 10 V or less.</li> <li>• When ignition voltage is 16 V or more.</li> </ul>	<ul style="list-style-type: none"> <li>• Harness or connector</li> <li>• ABS actuator and electric unit (control unit)</li> <li>• Fuse</li> <li>• Ignition power supply system</li> <li>• Battery</li> </ul>

#### DTC CONFIRMATION PROCEDURE

##### 1. CHECK SELF DIAGNOSTIC RESULT

Ⓜ With CONSULT.

1. Turn the ignition switch OFF to ON.
2. Perform "Self Diagnostic Result".

Is DTC C1109 detected?

- YES >> Proceed to diagnosis procedure. Refer to [BRC-78, "Diagnosis Procedure"](#).  
 NO >> Inspection End.

#### Diagnosis Procedure

INFOID:000000011280601

Regarding Wiring Diagram information, refer to [BRC-55, "Wiring Diagram"](#).

##### 1. CONNECTOR INSPECTION

1. Turn ignition switch OFF.
2. Disconnect ABS actuator and electric unit (control unit) connectors.
3. Check connectors and terminals for deformation, disconnection, looseness or damage.

Is the inspection result normal?

- YES >> GO TO 2.  
 NO >> Repair or replace as necessary.

##### 2. CHECK ABS ACTUATOR AND ELECTRIC UNIT (CONTROL UNIT) IGNITION POWER SUPPLY CIRCUIT

Check voltage between ABS actuator and electric unit (control unit) connector E125 terminal 28 and ground.

ABS actuator and electric unit (control unit)		Ground	Condition	Voltage (Approx.)
Connector	Terminal			
E125	28	—	Ignition switch ON	Battery voltage
			Ignition switch OFF	0V

Is the inspection result normal?

- YES >> GO TO 3.  
 NO >> Repair or replace malfunctioning components.

##### 3. CHECK ABS ACTUATOR AND ELECTRIC UNIT (CONTROL UNIT) BATTERY POWER SUPPLY CIRCUIT

Check voltage between ABS actuator and electric unit (control unit) connector E125 terminals 1, 25 and ground.

ABS actuator and electric unit (control unit)		Ground	Voltage (Approx.)
Connector	Terminal		

# C1109 POWER AND GROUND SYSTEM

< DTC/CIRCUIT DIAGNOSIS >

[VDC/TCS/ABS]

E125	1	—	Battery voltage
	25		

A

Is the inspection result normal?

YES >> GO TO 4.

NO >> Repair or replace malfunctioning components.

B

## 4. CHECK ABS ACTUATOR AND ELECTRIC UNIT (CONTROL UNIT) GROUND CIRCUIT

1. Turn ignition switch OFF.
2. Check continuity between ABS actuator and electric unit (control unit) connector E125 terminals 13, 38 and ground.

C

ABS actuator and electric unit (control unit)		—	Continuity
Connector	Terminal		
E125	13	Ground	Yes
	38		

D

E

Is the inspection result normal?

YES >> Replace ABS actuator and electric unit (control unit). Refer to [BRC-134, "Removal and Installation"](#).

NO >> Repair or replace malfunctioning components.

BRC

G

H

I

J

K

L

M

N

O

P

# C1111 PUMP MOTOR

< DTC/CIRCUIT DIAGNOSIS >

[VDC/TCS/ABS]

## C1111 PUMP MOTOR

### DTC Logic

INFOID:000000011280602

#### DTC DETECTION LOGIC

DTC	Display Item	Malfunction detected condition	Possible causes
C1111	PUMP MOTOR	When a malfunction is detected in motor or motor relay.	<ul style="list-style-type: none"><li>• Harness or connector</li><li>• ABS actuator and electric unit (control unit)</li><li>• Fusible link</li><li>• Battery power supply system</li></ul>

#### DTC CONFIRMATION PROCEDURE

##### 1. CHECK SELF DIAGNOSTIC RESULT

Ⓜ With CONSULT.

1. Turn ignition switch OFF.
2. Depress brake pedal 20 times or more.
3. Start the engine and wait for 3 minutes or more.
4. Perform "Self Diagnostic Result".

##### Is DTC C1111 detected?

- YES >> Proceed to diagnosis procedure. Refer to [BRC-80. "Diagnosis Procedure"](#).  
NO >> Inspection End.

#### Diagnosis Procedure

INFOID:000000011280603

Regarding Wiring Diagram information, refer to [BRC-55. "Wiring Diagram"](#).

##### 1. CONNECTOR INSPECTION

1. Turn ignition switch OFF.
2. Disconnect ABS actuator and electric unit (control unit) connectors.
3. Check connectors and terminals for deformation, disconnection, looseness or damage.

##### Is the inspection result normal?

- YES >> GO TO 2.  
NO >> Repair or replace as necessary.

##### 2. CHECK ABS MOTOR AND MOTOR RELAY BATTERY POWER SUPPLY

Check voltage between ABS actuator and electric unit (control unit) connector E125 terminal 1 and ground.

ABS actuator and electric unit (control unit)		—	Voltage (Approx.)
Connector	Terminal		
E125	1	Ground	Battery voltage

##### Is the inspection result normal?

- YES >> GO TO 3.  
NO >> Repair or replace malfunctioning components.

##### 3. CHECK ABS ACTUATOR AND ELECTRIC UNIT (CONTROL UNIT) GROUND CIRCUIT

Check continuity between ABS actuator and electric unit (control unit) connector E125 terminals 13, 38 and ground.



# C1111 PUMP MOTOR

< DTC/CIRCUIT DIAGNOSIS >

[VDC/TCS/ABS]

ABS actuator and electric unit (control unit)		—	Continuity
Connector	Terminal		
E125	13	Ground	Yes
	38		

Is the inspection result normal?

YES >> Replace ABS actuator and electric unit (control unit). Refer to [BRC-134, "Removal and Installation"](#)

NO >> Repair or replace harness.

A  
B  
C  
D  
E  
G  
H  
I  
J  
K  
L  
M  
N  
O  
P

**BRC**

# C1113, C1145, C1146 YAW RATE/SIDE/DECEL G SENSOR

< DTC/CIRCUIT DIAGNOSIS >

[VDC/TCS/ABS]

## C1113, C1145, C1146 YAW RATE/SIDE/DECEL G SENSOR

### DTC Logic

INFOID:000000011280604

### DTC DETECTION LOGIC

DTC	Display Item	Malfunction detected condition	Possible causes
C1113	G SENSOR	When a malfunction is detected in longitudinal G sensor signal.	<ul style="list-style-type: none"><li>• Harness or connector</li><li>• Yaw rate/side/decel G sensor</li><li>• ABS actuator and electric unit (control unit)</li><li>• Ignition power supply system</li><li>• Fuse</li></ul>
C1145	YAW RATE SENSOR	<ul style="list-style-type: none"><li>• When a malfunction is detected in yaw rate signal.</li><li>• When yaw rate signal is not continuously received for 2 seconds or more.</li><li>• When side G signal is not continuously received for 2 seconds or more.</li><li>• When decel G signal is not continuously received for 2 seconds or more.</li></ul>	
C1146	SIDE G-SEN CIRCUIT	When a malfunction is detected in side/decel G signal.	

### DTC CONFIRMATION PROCEDURE

#### 1. CHECK SELF DIAGNOSTIC RESULT

Ⓟ With CONSULT.

1. Turn ignition switch OFF to ON.
2. Perform "Self Diagnostic Result".

Is DTC C1113, C1145 or C1146 detected?

YES >> Proceed to diagnosis procedure. Refer to [BRC-82, "Diagnosis Procedure"](#).

NO >> Inspection End.

### Diagnosis Procedure

INFOID:000000011280605

#### 1. REPLACE ABS ACTUATOR AND ELECTRIC UNIT (CONTROL UNIT)

Replace ABS actuator and electric unit (control unit).

>> Replace ABS actuator and electric unit (control unit). Refer to [BRC-134, "Removal and Installation"](#).

# C1115 ABS SENSOR [ABNORMAL SIGNAL]

< DTC/CIRCUIT DIAGNOSIS >

[VDC/TCS/ABS]

## C1115 ABS SENSOR [ABNORMAL SIGNAL]

### DTC Logic

INFOID:000000011280606

### DTC DETECTION LOGIC

DTC	Display Item	Malfunction detected condition	Possible causes
C1115	ABS SENSOR [ABNORMAL SIGNAL]	When difference in wheel speed between any wheel and others is detected while the vehicle is driven because of installation of tires other than specified.	<ul style="list-style-type: none"><li>• Harness or connector</li><li>• Wheel sensor</li><li>• Sensor rotor</li><li>• ABS actuator and electric unit (control unit)</li></ul>

### DTC CONFIRMATION PROCEDURE

#### 1. CHECK SELF DIAGNOSTIC RESULT

Ⓜ With CONSULT.

1. Start engine and drive vehicle at approximately 30 km/h (19 MPH) or more for approximately 1 minute.
2. Perform "Self Diagnostic Result".

Is DTC C1115 detected?

- YES >> Proceed to diagnosis procedure. Refer to [BRC-83, "Diagnosis Procedure"](#).  
NO >> Inspection End.

### Diagnosis Procedure

INFOID:000000011280607

Regarding Wiring Diagram information, refer to [BRC-55, "Wiring Diagram"](#).

#### **CAUTION:**

**Do not check between wheel sensor terminals.**

#### 1. CONNECTOR INSPECTION

1. Disconnect ABS actuator and electric unit (control unit) connector E125 and wheel sensor connector of wheel with DTC.
2. Check terminals for deformation, disconnection, looseness or damage.

Is the inspection result normal?

- YES >> GO TO 2.  
NO >> Repair or replace as necessary.

#### 2. CHECK WHEEL SENSOR OUTPUT SIGNAL

1. Connect ABS active wheel sensor tester (J-45741) to wheel sensor using appropriate adapter.
2. Turn on the ABS active wheel sensor tester power switch.

##### **NOTE:**

The green POWER indicator should illuminate. If the POWER indicator does not illuminate, replace the battery in the ABS active wheel sensor tester before proceeding.

3. Spin the wheel of the vehicle by hand and observe the red SENSOR indicator on the ABS active wheel sensor tester. The red SENSOR indicator should flash on and off to indicate an output signal.

##### **NOTE:**

If the red SENSOR indicator illuminates but does not flash, reverse the polarity of the tester leads and retest.

Does the ABS active wheel sensor tester detect a signal?

- YES >> GO TO 3.  
NO >> Replace the wheel sensor. Refer to [BRC-130, "FRONT WHEEL SENSOR : Removal and Installation"](#) or [BRC-132, "REAR WHEEL SENSOR : Removal and Installation"](#).

#### 3. CHECK TIRES

Check the inflation pressure, wear and size of each tire.

Is the inspection result normal?

## C1115 ABS SENSOR [ABNORMAL SIGNAL]

< DTC/CIRCUIT DIAGNOSIS >

[VDC/TCS/ABS]

- YES >> GO TO 4.  
 NO >> Adjust tire pressure, or replace tire(s).

### 4. CHECK WIRING HARNESS FOR SHORT CIRCUIT

Check continuity between wheel sensor connector terminals and ground of wheel with DTC.

Wheel Sensor			Ground	Continuity
Wheel	Connector	Terminal		
Front LH	E18	1	—	No
		2		
Front RH	E43	1		
		2		
Rear LH	B58	1		
		2		
Rear RH	B60	1		
		2		

Is the inspection result normal?

- YES >> GO TO 5.  
 NO >> Repair the circuit.

### 5. CHECK WIRING HARNESS FOR OPEN CIRCUIT

Check continuity between ABS actuator and electric unit (control unit) connector E125 and wheel sensor connector of wheel with DTC.

Wheel sensor	ABS actuator and electric unit (control unit)		Wheel sensor		Continuity
	Connector	Terminal	Connector	Terminal	
Front LH	E125	19	E18	1	Yes
		8		2	
Front RH		16	E43	1	
		4		2	
Rear LH		31	B58	1	
		18		2	
Rear RH		17	B60	1	
		29		2	

Is the inspection result normal?

- YES >> Replace the ABS actuator and electric unit (control unit). Refer to [BRC-134, "Removal and Installation"](#).  
 NO >> Repair the circuit.

# C1120, C1122, C1124, C1126 ABS IN VALVE SYSTEM

< DTC/CIRCUIT DIAGNOSIS >

[VDC/TCS/ABS]

## C1120, C1122, C1124, C1126 ABS IN VALVE SYSTEM

### DTC Logic

INFOID:0000000011280608

### DTC DETECTION LOGIC

DTC	Display Item	Malfunction detected condition	Possible causes
C1120	FR LH IN ABS SOL	When a malfunction is detected in front LH ABS IN valve.	<ul style="list-style-type: none"> <li>• Harness or connector</li> <li>• ABS actuator and electric unit (control unit)</li> <li>• Fusible link</li> <li>• Battery power supply system</li> </ul>
C1122	FR RH IN ABS SOL	When a malfunction is detected in front RH ABS IN valve.	
C1124	RR LH IN ABS SOL	When a malfunction is detected in rear LH ABS IN valve.	
C1126	RR RH IN ABS SOL	When a malfunction is detected in rear RH ABS IN valve.	

### DTC CONFIRMATION PROCEDURE

#### 1. CHECK SELF DIAGNOSTIC RESULT

Ⓜ With CONSULT.

1. Turn ignition switch OFF to ON.
2. Perform "Self Diagnostic Result".

Is DTC C1120, C1122, C1124 or C1126 detected?

- YES >> Proceed to diagnosis procedure. Refer to [BRC-85, "Diagnosis Procedure"](#).  
 NO >> Inspection End.

### Diagnosis Procedure

INFOID:0000000011280609

Regarding Wiring Diagram information, refer to [BRC-55, "Wiring Diagram"](#).

#### 1. CONNECTOR INSPECTION

1. Turn ignition switch OFF.
2. Disconnect ABS actuator and electric unit (control unit) connectors.
3. Check connectors and terminals for deformation, disconnection, looseness or damage.

Is the inspection result normal?

- YES >> GO TO 2.  
 NO >> Repair or replace as necessary.

#### 2. CHECK ABS ACTUATOR AND ELECTRIC UNIT (CONTROL UNIT) BATTERY POWER SUPPLY

Check voltage between ABS actuator and electric unit (control unit) connector E125 terminal 25 and ground.

ABS actuator and electric unit (control unit)		—	Voltage (Approx.)
Connector	Terminal		
E125	25	Ground	Battery voltage

Is the inspection result normal?

- YES >> GO TO 3.  
 NO >> Repair or replace malfunctioning components.

#### 3. CHECK ABS ACTUATOR AND ELECTRIC UNIT (CONTROL UNIT) GROUND CIRCUIT

Check continuity between ABS actuator and electric unit (control unit) connector E125 terminals 13, 38 and ground.

# C1120, C1122, C1124, C1126 ABS IN VALVE SYSTEM

< DTC/CIRCUIT DIAGNOSIS >

[VDC/TCS/ABS]

ABS actuator and electric unit (control unit)		—	Continuity
Connector	Terminal		
E125	13	Ground	Yes
	38		

Is the inspection result normal?

YES >> Replace ABS actuator and electric unit (control unit). Refer to [BRC-134, "Removal and Installation"](#).

NO >> Repair or replace malfunctioning components.

# C1121, C1123, C1125, C1127 ABS OUT VALVE SYSTEM

< DTC/CIRCUIT DIAGNOSIS >

[VDC/TCS/ABS]

## C1121, C1123, C1125, C1127 ABS OUT VALVE SYSTEM

### DTC Logic

INFOID:0000000011280610

### DTC DETECTION LOGIC

DTC	Display Item	Malfunction detected condition	Possible causes
C1121	FR LH OUT ABS SOL	When a malfunction is detected in front LH ABS OUT valve.	<ul style="list-style-type: none"> <li>• Harness or connector</li> <li>• ABS actuator and electric unit (control unit)</li> <li>• Fusible link</li> <li>• Battery power supply system</li> </ul>
C1123	FR RH OUT ABS SOL	When a malfunction is detected in front RH ABS OUT valve.	
C1125	RR LH OUT ABS SOL	When a malfunction is detected in rear LH ABS OUT valve.	
C1127	RR RH OUT ABS SOL	When a malfunction is detected in rear RH ABS OUT valve.	

### DTC CONFIRMATION PROCEDURE

#### 1. CHECK SELF DIAGNOSTIC RESULT

☑ With CONSULT.

1. Turn ignition switch OFF to ON.
2. Perform "Self Diagnostic Result".

Is DTC C1121, C1123, C1125 or C1127 detected?

- YES >> Proceed to diagnosis procedure. Refer to [BRC-87, "Diagnosis Procedure"](#).  
 NO >> Inspection End.

### Diagnosis Procedure

INFOID:0000000011280611

Regarding Wiring Diagram information, refer to [BRC-55, "Wiring Diagram"](#).

#### 1. CONNECTOR INSPECTION

1. Turn ignition switch OFF.
2. Disconnect ABS actuator and electric unit (control unit) connectors.
3. Check connectors and terminals for deformation, disconnection, looseness or damage.

Is the inspection result normal?

- YES >> GO TO 2.  
 NO >> Repair or replace as necessary.

#### 2. CHECK ABS ACTUATOR AND ELECTRIC UNIT (CONTROL UNIT) BATTERY POWER SUPPLY

Check voltage between ABS actuator and electric unit (control unit) connector E125 terminal 25 and ground.

ABS actuator and electric unit (control unit)		—	Voltage (Approx.)
Connector	Terminal		
E125	25	Ground	Battery voltage

Is the inspection result normal?

- YES >> GO TO 3.  
 NO >> Repair or replace malfunctioning components.

#### 3. CHECK ABS ACTUATOR AND ELECTRIC UNIT (CONTROL UNIT) GROUND CIRCUIT

Check continuity between ABS actuator and electric unit (control unit) connector E125 terminals 13, 38 and ground.

# C1121, C1123, C1125, C1127 ABS OUT VALVE SYSTEM

< DTC/CIRCUIT DIAGNOSIS >

[VDC/TCS/ABS]

ABS actuator and electric unit (control unit)		—	Continuity
Connector	Terminal		
E125	13	Ground	Yes
	38		

Is the inspection result normal?

YES >> Replace ABS actuator and electric unit (control unit). Refer to [BRC-134, "Removal and Installation"](#).

NO >> Repair or replace malfunctioning components.



# C1130 ENGINE SIGNAL

< DTC/CIRCUIT DIAGNOSIS >

[VDC/TCS/ABS]

## C1130 ENGINE SIGNAL

### DTC Logic

INFOID:000000011280612

### DTC DETECTION LOGIC

DTC	Display Item	Malfunction detected condition	Possible causes
C1130	ENGINE SIGNAL 1	When a malfunction is detected in ECM system.	<ul style="list-style-type: none"><li>• ECM</li><li>• ABS actuator and electric unit (control unit)</li><li>• CAN communication line</li></ul>

### DTC CONFIRMATION PROCEDURE

#### 1. CHECK SELF DIAGNOSTIC RESULT

Ⓜ With CONSULT.

1. Turn ignition switch OFF to ON.
2. Perform "Self Diagnostic Result".

Is DTC C1130 detected?

- YES >> Proceed to diagnosis procedure. Refer to [BRC-89, "Diagnosis Procedure"](#).  
NO >> Inspection End.

### Diagnosis Procedure

INFOID:000000011280613

#### 1. CHECK SELF DIAGNOSTIC RESULT FOR ENGINE SYSTEM

Ⓜ With CONSULT.

Perform "Self Diagnostic Result". Refer to [EC-69, "CONSULT Function"](#).

Are any ECM DTCs detected?

- YES >> Refer to [EC-96, "DTC Index"](#).  
NO >> GO TO 2.

#### 2. CHECK SELF DIAGNOSTIC RESULT FOR ABS ACTUATOR AND ELECTRIC UNIT (CONTROL UNIT)

Ⓜ With CONSULT.

1. Perform "Self Diagnostic Result" and erase DTCs.
2. Turn ignition switch OFF.
3. Start engine and drive vehicle for a short period of time.
4. Check that malfunction indicator lamp (MIL) turns OFF.
5. Stop vehicle and perform "Self Diagnostic Result".

Is DTC C1130 detected?

- YES >> Replace ABS actuator and electric unit (control unit). Refer to [BRC-134, "Removal and Installation"](#).  
NO >> Check pin terminals and connection of connectors for abnormal conditions. Repair or replace malfunctioning components.

# C1140 ACTUATOR RELAY SYSTEM

< DTC/CIRCUIT DIAGNOSIS >

[VDC/TCS/ABS]

## C1140 ACTUATOR RELAY SYSTEM

### DTC Logic

INFOID:000000011280614

#### DTC DETECTION LOGIC

DTC	Display Item	Malfunction detected condition	Possible causes
C1140	ACTUATOR RLY	When a malfunction is detected in actuator relay.	<ul style="list-style-type: none"><li>• Harness or connector</li><li>• ABS actuator and electric unit (control unit)</li><li>• Fusible link</li><li>• Battery power supply system</li></ul>

#### DTC CONFIRMATION PROCEDURE

##### 1.CHECK SELF-DIAGNOSTIC RESULT

Ⓜ With CONSULT.

1. Turn ignition switch OFF to ON.
2. Perform "Self Diagnostic Result".

Is DTC C1140 detected?

- YES >> Proceed to diagnosis procedure. Refer to [BRC-90, "Diagnosis Procedure"](#).  
NO >> Inspection End.

#### Diagnosis Procedure

INFOID:000000011280615

Regarding Wiring Diagram information, refer to [BRC-55, "Wiring Diagram"](#).

##### 1.CONNECTOR INSPECTION

1. Turn ignition switch OFF.
2. Disconnect ABS actuator and electric unit (control unit) connectors.
3. Check connectors and terminals for deformation, disconnection, looseness or damage.

Is the inspection result normal?

- YES >> GO TO 2.  
NO >> Repair or replace as necessary.

##### 2.CHECK ABS ACTUATOR AND ELECTRIC UNIT (CONTROL UNIT) BATTERY POWER SUPPLY

Check voltage between ABS actuator and electric unit (control unit) connector E125 terminals 1, 25 and ground.

ABS actuator and electric unit (control unit)		—	Voltage (Approx.)
Connector	Terminal		
E125	1	Ground	Battery voltage
	25		

Is the inspection result normal?

- YES >> GO TO 3.  
NO >> Repair or replace malfunctioning components.

##### 3.CHECK ABS ACTUATOR AND ELECTRIC UNIT (CONTROL UNIT) GROUND CIRCUIT

Check continuity between ABS actuator and electric unit (control unit) connector E125 terminals 13, 38 and ground.

# C1140 ACTUATOR RELAY SYSTEM

< DTC/CIRCUIT DIAGNOSIS >

[VDC/TCS/ABS]

ABS actuator and electric unit (control unit)		—	Continuity
Connector	Terminal		
E125	13	Ground	Yes
	38		

Is the inspection result normal?

- YES >> Replace ABS actuator and electric unit (control unit). Refer to [BRC-134, "Removal and Installation"](#).
- NO >> Repair or replace malfunctioning components.

A  
B  
C  
D  
E  
G  
H  
I  
J  
K  
L  
M  
N  
O  
P

BRC

# C1142 PRESS SENSOR

< DTC/CIRCUIT DIAGNOSIS >

[VDC/TCS/ABS]

## C1142 PRESS SENSOR

### DTC Logic

INFOID:000000011280616

### DTC DETECTION LOGIC

DTC	Display Item	Malfunction detected condition	Possible causes
C1142	PRESS SEN CIRCUIT	When a malfunction is detected in master cylinder pressure sensor.	<ul style="list-style-type: none"><li>• Stop lamp switch system</li><li>• ABS actuator and electric unit (control unit)</li><li>• Brake system</li></ul>

### DTC CONFIRMATION PROCEDURE

#### 1. CHECK SELF DIAGNOSTIC RESULT

Ⓜ With CONSULT.

1. Turn ignition switch OFF to ON.
2. Perform "Self Diagnostic Result".

Is DTC C1142 detected?

- YES >> Proceed to diagnosis procedure. Refer to [BRC-92, "Diagnosis Procedure"](#).  
NO >> Inspection End.

### Diagnosis Procedure

INFOID:000000011280617

#### 1. CHECK STOP LAMP SWITCH SYSTEM

Check stop lamp switch system. Refer to [BR-7, "Inspection"](#).

Is the inspection result normal?

- YES >> GO TO 2.  
NO >> Repair or replace malfunctioning components.

#### 2. CHECK BRAKE FLUID LEAKAGE

Check brake fluid leakage. Refer to [BR-8, "Inspection"](#).

Is the inspection result normal?

- YES >> GO TO 3.  
NO >> Repair or replace malfunctioning components.

#### 3. CHECK BRAKE PEDAL

Check brake pedal. Refer to [BR-7, "Inspection"](#).

Is the inspection result normal?

- YES >> GO TO 4.  
NO >> Repair or replace malfunctioning components.

#### 4. CHECK HYDRAULIC BOOSTER ASSEMBLY

Check hydraulic booster assembly. Refer to [BR-10, "Inspection"](#).

Is the inspection result normal?

- YES >> GO TO 5.  
NO >> Repair or replace malfunctioning components.

#### 5. CHECK SELF DIAGNOSTIC RESULT

Ⓜ With CONSULT.

1. Turn ignition switch OFF to ON.
2. Perform "Self Diagnostic Result".
3. Erase DTCs.
4. Start engine and drive vehicle for a short period of time.
5. Turn ignition switch OFF to ON.

# C1142 PRESS SENSOR

[VDC/TCS/ABS]

< DTC/CIRCUIT DIAGNOSIS >

6. Perform "Self Diagnostic Result".

Is DTC C1142 detected?

YES >> Replace ABS actuator and electric unit (control unit). Refer to [BRC-134. "Removal and Installation"](#).

NO >> Inspection End.

A  
B  
C  
D  
E  
G  
H  
I  
J  
K  
L  
M  
N  
O  
P

**BRC**

# C1143 STEERING ANGLE SENSOR

< DTC/CIRCUIT DIAGNOSIS >

[VDC/TCS/ABS]

## C1143 STEERING ANGLE SENSOR

### DTC Logic

INFOID:000000011280618

### DTC DETECTION LOGIC

DTC	Display Item	Malfunction detected condition	Possible causes
C1143	ST ANG SEN CIRCUIT	When a malfunction is detected in steering angle sensor.	<ul style="list-style-type: none"><li>• Harness or connector</li><li>• Steering angle sensor</li><li>• ABS actuator and electric unit (control unit)</li><li>• Fuse</li><li>• Ignition power supply system</li><li>• CAN communication line</li></ul>

### DTC CONFIRMATION PROCEDURE

#### 1.CHECK SELF DIAGNOSTIC RESULT

④With CONSULT.

1. Turn ignition switch OFF to ON.
2. Perform "Self Diagnostic Result".

Is DTC C1143 detected?

- YES >> Proceed to diagnosis procedure. Refer to [BRC-94, "Diagnosis Procedure"](#).  
NO >> Inspection End.

### Diagnosis Procedure

INFOID:000000011280619

Regarding Wiring Diagram information, refer to [BRC-55, "Wiring Diagram"](#).

#### 1.CONNECTOR INSPECTION

1. Turn ignition switch OFF.
2. Disconnect ABS actuator and electric unit (control unit) and steering angle sensor connectors.
3. Check connectors and terminals for deformation, disconnection, looseness or damage.

Is the inspection result normal?

- YES >> GO TO 2.  
NO >> Repair or replace as necessary.

#### 2.CHECK STEERING ANGLE SENSOR MOUNTING CONDITION

Check steering angle sensor mounting condition.

Is the inspection result normal?

- YES >> GO TO 3.  
NO >> Repair or replace malfunctioning components.

#### 3.CHECK STEERING ANGLE SENSOR POWER SUPPLY

1. Turn ignition switch OFF.
2. Disconnect steering angle sensor connector.
3. Turn ignition switch ON.
4. Check voltage between steering angle sensor connector M56 terminal 4 and ground.

Steering angle sensor		—	Voltage (Approx.)
Connector	Terminal		
M56	4	Ground	Battery voltage

Is the inspection result normal?

- YES >> GO TO 5.

# C1143 STEERING ANGLE SENSOR

[VDC/TCS/ABS]

< DTC/CIRCUIT DIAGNOSIS >

NO >> GO TO 4.

## 4. CHECK STEERING ANGLE SENSOR POWER SUPPLY CIRCUIT

1. Turn ignition switch OFF.
2. Disconnect fuse block (J/B) connector M44.
3. Check continuity between steering angle sensor connector M56 terminal 4 and Fuse block (J/B) connector M44 terminal 7P.

Steering angle sensor		Fuse block (J/B)		Continuity
Connector	Terminal	Connector	Terminal	
M56	4	M44	7P	Yes

4. Check continuity between steering angle sensor connector M54 terminal 4 and ground.

Steering angle sensor		—	Continuity
Connector	Terminal		
M56	4	Ground	No

Is the inspection result normal?

YES >> Perform trouble diagnosis for ignition power supply.

NO >> Repair or replace malfunctioning components.

## 5. CHECK STEERING ANGLE SENSOR GROUND CIRCUIT

1. Turn ignition switch OFF.
2. Check continuity between steering angle sensor connector M56 terminal 1 and ground.

Steering angle sensor		—	Continuity
Connector	Terminal		
M56	1	Ground	Yes

Is the inspection result normal?

YES >> GO TO 6.

NO >> Repair or replace malfunctioning components.

## 6. CHECK CAN COMMUNICATION LINE

Check "STRG BRANCH LINE CIRCUIT". Refer to [LAN-92, "Diagnosis Procedure"](#) (Type 1) or [LAN-113, "Diagnosis Procedure"](#) (Type 2).

Is the inspection result normal?

YES >> Replace ABS actuator and electric unit (control unit). Refer to [BRC-134, "Removal and Installation"](#).

NO >> Repair or replace malfunctioning components.

# C1144 INCOMPLETE STEERING ANGLE SENSOR ADJUSTMENT

< DTC/CIRCUIT DIAGNOSIS >

[VDC/TCS/ABS]

## C1144 INCOMPLETE STEERING ANGLE SENSOR ADJUSTMENT

### DTC Logic

INFOID:000000011280620

### DTC DETECTION LOGIC

DTC	Display Item	Malfunction detected condition	Possible causes
C1144	ST ANG SEN SIGNAL	When neutral position adjustment of steering angle sensor is not complete.	<ul style="list-style-type: none"><li>• Harness or connector</li><li>• Steering angle sensor</li><li>• ABS actuator and electric unit (control unit)</li><li>• Incomplete neutral position adjustment of steering angle sensor</li></ul>

### DTC CONFIRMATION PROCEDURE

#### 1. CHECK SELF-DIAGNOSTIC RESULT

Ⓢ With CONSULT.

1. Turn ignition switch OFF to ON.
2. Perform "Self Diagnostic Result".

Is DTC C1144 detected?

- YES >> Proceed to diagnosis procedure. Refer to [BRC-96, "Diagnosis Procedure"](#).  
NO >> Inspection End.

### Diagnosis Procedure

INFOID:000000011280621

#### 1. ADJUST THE NEUTRAL POSITION OF STEERING ANGLE SENSOR

Perform neutral position adjustment of steering angle sensor. Refer to [BRC-96, "Diagnosis Procedure"](#).

>> GO TO 2.

#### 2. CHECK SELF DIAGNOSTIC RESULT

Ⓢ With CONSULT.

Perform "Self Diagnostic Result".

Is DTC C1144 detected?

- YES >> GO TO 3.  
NO >> Inspection End.

#### 3. CHECK STEERING ANGLE SENSOR SYSTEM

Check steering angle sensor system. Refer to [BRC-94, "Diagnosis Procedure"](#).

Is the inspection result normal?

- YES >> Replace ABS actuator and electric unit (control unit). Refer to [BRC-134, "Removal and Installation"](#).  
NO >> Repair or replace malfunctioning components.



# C1155 BRAKE FLUID LEVEL SWITCH

< DTC/CIRCUIT DIAGNOSIS >

[VDC/TCS/ABS]

## C1155 BRAKE FLUID LEVEL SWITCH

### DTC Logic

INFOID:000000011280622

### DTC DETECTION LOGIC

DTC	Display Item	Malfunction detected condition	Possible causes
C1155	BR FLUID LEVEL LOW	When brake fluid level low signal is detected.	<ul style="list-style-type: none"><li>• Harness or connector</li><li>• ABS actuator and electric unit (control unit)</li><li>• Brake fluid level switch</li><li>• Combination meter</li></ul>

### DTC CONFIRMATION PROCEDURE

#### 1. CHECK SELF DIAGNOSTIC RESULT

Ⓜ With CONSULT.

1. Turn ignition switch OFF to ON and wait 1 minute or more.
2. Perform "Self Diagnostic Result".

Is DTC C1155 detected?

- YES >> Proceed to diagnosis procedure. Refer to [BRC-97, "Diagnosis Procedure"](#).  
NO >> Inspection End.

### Diagnosis Procedure

INFOID:000000011280623

Regarding Wiring Diagram information, refer to [BRC-55, "Wiring Diagram"](#).

#### 1. CHECK BRAKE FLUID LEVEL

1. Turn the ignition switch OFF.
2. Check brake fluid level. Refer to [BR-8, "Inspection"](#).

Is the inspection result normal?

- YES >> GO TO 2.  
NO >> Refill brake fluid. Refer to [BR-16, "Drain and Refill"](#).

#### 2. CONNECTOR INSPECTION

1. Turn ignition switch OFF.
2. Disconnect combination meter connector M76 and brake fluid level switch connector E63.
3. Check connectors and terminals for deformation, disconnection, looseness or damage.

Is the inspection result normal?

- YES >> GO TO 3.  
NO >> Repair or replace as necessary.

#### 3. CHECK BRAKE FLUID LEVEL SWITCH

Check brake fluid level switch. Refer to [BRC-98, "Component Inspection"](#).

Is the inspection result normal?

- YES >> GO TO 4.  
NO >> Replace reservoir tank. Refer to [BR-29, "Disassembly and Assembly"](#).

#### 4. CHECK BRAKE FLUID LEVEL SWITCH CIRCUIT

1. Turn the ignition switch OFF.
2. Disconnect brake fluid level switch harness connector.
3. Disconnect combination meter harness connector.
4. Check continuity between brake fluid level switch harness connector and combination meter harness connector.

# C1155 BRAKE FLUID LEVEL SWITCH

< DTC/CIRCUIT DIAGNOSIS >

[VDC/TCS/ABS]

Brake fluid level switch		Combination meter		Continuity
Connector	Terminal	Connector	Terminal	
E63	1	M76	25	Yes

5. Check continuity between brake fluid level switch harness connector and ground.

Brake fluid level switch		—	Continuity
Connector	Terminal		
E63	1	Ground	No

Is the inspection result normal?

- YES >> GO TO 5.
- NO >> Repair or replace malfunctioning components.

## 5. CHECK BRAKE FLUID LEVEL SWITCH GROUND CIRCUIT

Check continuity between brake fluid level switch harness connector and ground.

Brake fluid level switch		—	Continuity
Connector	Terminal		
E63	2	Ground	Yes

Is the inspection result normal?

- YES >> GO TO 6.
- NO >> Repair or replace malfunctioning components.

## 6. CHECK COMBINATION METER

Check if indication and operation of combination meter are normal. Refer to [MWI-8, "METER SYSTEM : System Description"](#).

Is the inspection result normal?

- YES >> Replace ABS actuator and electric unit (control unit). Refer to [BRC-134, "Removal and Installation"](#).
- NO >> Replace combination meter. Refer to [MWI-84, "Removal and Installation"](#).

## Component Inspection

INFOID:0000000011280624

### 1. CHECK BRAKE FLUID LEVEL SWITCH

1. Turn the ignition switch OFF.
2. Disconnect brake fluid level switch harness connector.
3. Check continuity between terminals of brake fluid level switch.

Brake fluid level switch	Condition	Continuity
Terminal		
1 – 2	When brake fluid level in reservoir tank is within the specified level.	No
	When brake fluid level in reservoir tank is less than the specified level.	Yes

Is the inspection result normal?

- YES >> Inspection End.
- NO >> Replace reservoir tank. Refer to [BR-29, "Disassembly and Assembly"](#).

# C1160 DECEL G SEN SET

< DTC/CIRCUIT DIAGNOSIS >

[VDC/TCS/ABS]

## C1160 DECEL G SEN SET

### DTC Logic

INFOID:000000011280625

### DTC DETECTION LOGIC

DTC	Display Item	Malfunction detected condition	Possible causes
C1160	DECEL G SEN SET	When calibration of yaw rate/side/decel G sensor is not complete.	<ul style="list-style-type: none"><li>• Yaw rate/side/decel G sensor</li><li>• Harness or connector</li><li>• ABS actuator and electric unit (control unit)</li><li>• Decel G sensor calibration is not performed</li></ul>

### DTC CONFIRMATION PROCEDURE

#### 1. CHECK SELF DIAGNOSTIC RESULT

Ⓜ With CONSULT.

1. Turn ignition switch OFF to ON.
2. Perform "Self Diagnostic Result".

Is DTC C1160 detected?

- YES >> Proceed to diagnosis procedure. Refer to [BRC-99, "Diagnosis Procedure"](#).  
NO >> Inspection End.

### Diagnosis Procedure

INFOID:000000011280626

#### 1. DECEL G SENSOR CALIBRATION

Perform decel G sensor calibration. Refer to [BRC-70, "Work Procedure"](#).

>> GO TO 2.

#### 2. CHECK SELF DIAGNOSTIC RESULT

Ⓜ With CONSULT.

Perform "Self Diagnostic Result".

Is DTC C1160 detected?

- YES >> GO TO 3.  
NO >> Inspection End.

#### 3. CHECK YAW RATE/SIDE/DECEL G SENSOR SYSTEM

Check yaw rate/side/decel G sensor system. Refer to [BRC-82, "Diagnosis Procedure"](#).

Is the inspection result normal?

- YES >> Replace ABS actuator and electric unit (control unit). Refer to [BRC-134, "Removal and Installation"](#).  
NO >> Repair or replace malfunctioning components.

# C1164, C1165 CV SYSTEM

< DTC/CIRCUIT DIAGNOSIS >

[VDC/TCS/ABS]

## C1164, C1165 CV SYSTEM

### DTC Logic

INFOID:000000011280627

#### DTC DETECTION LOGIC

DTC	Display Item	Malfunction detected condition	Possible causes
C1164	CV 1	When a malfunction is detected in cut valve 1.	<ul style="list-style-type: none"><li>• Harness or connector</li><li>• ABS actuator and electric unit (control unit)</li><li>• Fusible link</li><li>• Battery power supply system</li></ul>
C1165	CV 2	When a malfunction is detected in cut valve 2.	

#### DTC CONFIRMATION PROCEDURE

##### 1. CHECK SELF DIAGNOSTIC RESULT

Ⓜ With CONSULT.

1. Turn ignition switch ON.
2. Perform "Self Diagnostic Result".

Is DTC "C1164" or "C1165" detected?

- YES >> Proceed to diagnosis procedure. Refer to [BRC-100, "Diagnosis Procedure"](#).  
NO >> Inspection End.

#### Diagnosis Procedure

INFOID:000000011280628

Regarding Wiring Diagram information, refer to [BRC-55, "Wiring Diagram"](#).

##### 1. CONNECTOR INSPECTION

1. Turn ignition switch OFF.
2. Disconnect ABS actuator and electric unit (control unit) connectors.
3. Check connectors and terminals for deformation, disconnection, looseness or damage.

Is the inspection result normal?

- YES >> GO TO 2.  
NO >> Repair or replace as necessary.

##### 2. CHECK ABS ACTUATOR AND ELECTRIC UNIT (CONTROL UNIT) BATTERY POWER SUPPLY

Check voltage between ABS actuator and electric unit (control unit) connector E125 terminals 1, 25 and ground.

ABS actuator and electric unit (control unit)		—	Voltage (Approx.)
Connector	Terminal		
E125	1	Ground	Battery voltage
	25		

Is the inspection result normal?

- YES >> GO TO 3.  
NO >> Repair or replace malfunctioning components.

##### 3. CHECK ABS ACTUATOR AND ELECTRIC UNIT (CONTROL UNIT) GROUND CIRCUIT

Check continuity between ABS actuator and electric unit (control unit) connector E125 terminals 13, 38 and ground.

# C1164, C1165 CV SYSTEM

< DTC/CIRCUIT DIAGNOSIS >

[VDC/TCS/ABS]

ABS actuator and electric unit (control unit)		—	Continuity
Connector	Terminal		
E125	13	Ground	Yes
	38		

Is the inspection result normal?

- YES >> Replace ABS actuator and electric unit (control unit). Refer to [BRC-134, "Removal and Installation"](#).
- NO >> Repair or replace malfunctioning components.

A  
B  
C  
D  
E  
G  
H  
I  
J  
K  
L  
M  
N  
O  
P

BRC

# C1170 VARIANT CODING

< DTC/CIRCUIT DIAGNOSIS >

[VDC/TCS/ABS]

## C1170 VARIANT CODING

### DTC Logic

INFOID:000000011280629

### DTC DETECTION LOGIC

DTC	Display Item	Malfunction detected condition	Possible causes
C1170	VARIANT CODING	When the information in ABS actuator and electric unit (control unit) is not the same.	ABS actuator and electric unit (control unit)

### DTC CONFIRMATION PROCEDURE

#### 1. CHECK SELF DIAGNOSTIC RESULT

Ⓜ With CONSULT.

1. Turn ignition switch ON.
2. Perform "Self Diagnostic Result".

#### Is DTC C1170 detected?

- YES >> Proceed to diagnosis procedure. Refer to [BRC-102, "Diagnosis Procedure"](#).  
NO >> Inspection End.

### Diagnosis Procedure

INFOID:000000011280630

#### 1. REPLACE ABS ACTUATOR AND ELECTRIC UNIT (CONTROL UNIT)

Replace ABS actuator and electric unit (control unit) even if other DTCs are displayed with "VARIANT CODING" in "Self Diagnostic Result".

- >> Replace ABS actuator and electric unit (control unit). Refer to [BRC-134, "Removal and Installation"](#).

# C1197 VACUUM SENSOR

< DTC/CIRCUIT DIAGNOSIS >

[VDC/TCS/ABS]

## C1197 VACUUM SENSOR

### DTC Logic

INFOID:000000011280631

### DTC DETECTION LOGIC

DTC	Display Item	Malfunction detected condition	Possible causes
C1197	VACUUM SENSOR	When a malfunction is detected in vacuum sensor.	<ul style="list-style-type: none"> <li>• Harness or connector</li> <li>• Vacuum sensor (brake booster)</li> <li>• Vacuum piping</li> <li>• ABS actuator and electric unit (control unit)</li> </ul>

### DTC CONFIRMATION PROCEDURE

#### 1. CHECK SELF DIAGNOSTIC RESULT

 With CONSULT.

1. Turn the ignition switch ON.
2. Perform "Self Diagnostic Result".

#### Is DTC C1197 detected?

- YES >> Proceed to diagnosis procedure. Refer to [BRC-103, "Diagnosis Procedure"](#).  
 NO >> Inspection End.

### Diagnosis Procedure

INFOID:000000011280632

Regarding Wiring Diagram information, refer to [BRC-55, "Wiring Diagram"](#).

#### 1. CHECK BRAKE BOOSTER

1. Turn the ignition switch OFF.
2. Check brake booster. Refer to [BR-10, "Inspection"](#).

#### Is the inspection result normal?

- YES >> GO TO 2.  
 NO >> Replace brake booster. Refer to [BR-31, "Removal and installation"](#).

#### 2. CHECK VACUUM PIPING

Check vacuum piping. Refer to [BR-33, "Exploded View"](#).

#### Is the inspection result normal?

- YES >> GO TO 3.  
 NO >> Replace vacuum piping. Refer to [BR-33, "Removal and Installation"](#).

#### 3. CHECK VACUUM SENSOR CIRCUIT

1. Disconnect vacuum sensor harness connector.
2. Disconnect ABS actuator and electric unit (control unit) harness connector.
3. Check continuity between vacuum sensor harness connector and ABS actuator and electric unit (control unit) harness connector.

Vacuum sensor		ABS actuator and electric unit (control unit)		Continuity
Connector	Terminal	Connector	Terminal	
E167	1	E125	12	Yes
	2		24	
	3		5	

4. Check continuity between vacuum sensor harness connector and ground.

# C1197 VACUUM SENSOR

< DTC/CIRCUIT DIAGNOSIS >

[VDC/TCS/ABS]

Vacuum sensor		—	Continuity
Connector	Terminal		
E167	1	Ground	No
	2		
	3		

Is the inspection result normal?

YES >> GO TO 4.

NO >> Repair or replace malfunctioning components.

## 4.CHECK TERMINAL

- Check vacuum sensor pin terminals for damage or loose connection with harness connector.
- Check ABS actuator and electric unit (control unit) pin terminals for damage or loose connection with harness connector.

Is the inspection result normal?

YES >> GO TO 5.

NO >> Repair or replace malfunctioning components.

## 5.REPLACE VACUUM SENSOR

ⓅWith CONSULT

1. Connect ABS actuator and electric unit (control unit) harness connector.
2. Replace vacuum sensor. Refer to [BR-31, "Exploded View"](#).

**CAUTION:**

**Always replace brake booster because vacuum sensor cannot be disassembled.**

3. Erase "Self Diagnostic Result" of "ABS".
4. Turn the ignition switch OFF.
5. Start engine.
6. Perform "Self Diagnostic Result" of "ABS".

Is DTC "C1197" detected?

YES >> Replace ABS actuator and electric unit (control unit). Refer to [BRC-134, "Removal and Installation"](#).

NO >> Inspection End.



# C1198 VACUUM SENSOR

< DTC/CIRCUIT DIAGNOSIS >

[VDC/TCS/ABS]

## C1198 VACUUM SENSOR

### DTC Logic

INFOID:0000000011280633

### DTC DETECTION LOGIC

DTC	Display Item	Malfunction detected condition	Possible causes
C1198	VACUUM SEN CIR	<ul style="list-style-type: none"> <li>When an open circuit is detected in vacuum sensor circuit.</li> <li>When a short circuit is detected in vacuum sensor circuit.</li> <li>When a malfunction is detected in vacuum sensor noise.</li> </ul>	<ul style="list-style-type: none"> <li>Harness or connector</li> <li>Vacuum sensor (brake booster)</li> <li>ABS actuator and electric unit (control unit)</li> </ul>

### DTC CONFIRMATION PROCEDURE

#### 1. CHECK SELF DIAGNOSTIC RESULT

Ⓜ With CONSULT.

- Turn the ignition switch ON.
- Perform "Self Diagnostic Result".

#### Is DTC C1198 detected?

YES >> Proceed to diagnosis procedure. Refer to [BRC-105, "Diagnosis Procedure"](#).

NO >> Inspection End.

### Diagnosis Procedure

INFOID:0000000011280634

Regarding Wiring Diagram information, refer to [BRC-55, "Wiring Diagram"](#).

#### 1. CHECK VACUUM SENSOR CIRCUIT

- Turn the ignition switch OFF.
- Disconnect vacuum sensor harness connector.
- Disconnect ABS actuator and electric unit (control unit) harness connector.
- Check continuity between vacuum sensor harness connector and ABS actuator and electric unit (control unit) harness connector.

Vacuum sensor		ABS actuator and electric unit (control unit)		Continuity
Connector	Terminal	Connector	Terminal	
E167	1	E125	12	Yes
	2		24	
	3		5	

- Check continuity between vacuum sensor harness connector and ground.

Vacuum sensor		—	Continuity
Connector	Terminal		
E167	1	Ground	No
	2		
	3		

#### Is the inspection result normal?

YES >> GO TO 2.

NO >> Repair or replace malfunctioning components.

#### 2. CHECK TERMINAL

## C1198 VACUUM SENSOR

[VDC/TCS/ABS]

< DTC/CIRCUIT DIAGNOSIS >

- Check vacuum sensor pin terminals for damage or loose connection with harness connector.
- Check ABS actuator and electric unit (control unit) pin terminals for damage or loose connection with harness connector.

Is the inspection result normal?

YES >> GO TO 3.

NO >> Repair or replace malfunctioning components.

### 3.REPLACE VACUUM SENSOR

---

ⓅWith CONSULT

1. Connect ABS actuator and electric unit (control unit) harness connector.
2. Replace vacuum sensor. Refer to [BR-31, "Exploded View"](#).

**CAUTION:**

**Always replace brake booster because vacuum sensor cannot be disassembled.**

3. Erase "Self Diagnostic Result" of "ABS".
4. Turn the ignition switch OFF.
5. Start engine.
6. Perform "Self Diagnostic Result" of "ABS".

Is DTC "C1198" detected?

YES >> Replace ABS actuator and electric unit (control unit). Refer to [BRC-134, "Removal and Installation"](#).

NO >> Inspection End.

# C1199 BRAKE BOOSTER

< DTC/CIRCUIT DIAGNOSIS >

[VDC/TCS/ABS]

## C1199 BRAKE BOOSTER

### DTC Logic

INFOID:000000011280635

### DTC DETECTION LOGIC

DTC	Display Item	Malfunction detected condition	Possible causes
C1199	BRAKE BOOSTER	When brake booster vacuum is approx. 0 kPa (0 mm-Hg) during engine running.	<ul style="list-style-type: none"><li>• Harness or connector</li><li>• Vacuum sensor (brake booster)</li><li>• Vacuum piping</li><li>• ABS actuator and electric unit (control unit)</li></ul>

### DTC CONFIRMATION PROCEDURE

#### 1. CHECK SELF DIAGNOSTIC RESULT

Ⓜ With CONSULT.

1. Turn the ignition switch ON.
2. Perform "Self Diagnostic Result".

#### Is DTC C1199 detected?

- YES >> Proceed to diagnosis procedure. Refer to [BRC-107, "Diagnosis Procedure"](#).  
NO >> Inspection End.

### Diagnosis Procedure

INFOID:000000011280636

Regarding Wiring Diagram information, refer to [BRC-55, "Wiring Diagram"](#).

#### 1. CHECK BRAKE BOOSTER

1. Turn the ignition switch OFF.
2. Check brake booster. Refer to [BR-10, "Inspection"](#).

#### Is the inspection result normal?

- YES >> GO TO 2.  
NO >> Replace brake booster. Refer to [BR-31, "Removal and installation"](#).

#### 2. CHECK VACUUM PIPING

Check vacuum piping. Refer to [BR-33, "Exploded View"](#).

#### Is the inspection result normal?

- YES >> GO TO 3.  
NO >> Replace vacuum piping. Refer to [BR-33, "Removal and Installation"](#).

#### 3. CHECK VACUUM SENSOR CIRCUIT

1. Disconnect vacuum sensor harness connector.
2. Disconnect ABS actuator and electric unit (control unit) harness connector.
3. Check continuity between vacuum sensor harness connector and ABS actuator and electric unit (control unit) harness connector.

Vacuum sensor		ABS actuator and electric unit (control unit)		Continuity
Connector	Terminal	Connector	Terminal	
E167	1	E125	12	Yes
	2		24	
	3		5	

4. Check continuity between vacuum sensor harness connector and ground.

# C1199 BRAKE BOOSTER

< DTC/CIRCUIT DIAGNOSIS >

[VDC/TCS/ABS]

Vacuum sensor		—	Continuity
Connector	Terminal		
E167	1	Ground	No
	2		
	3		

Is the inspection result normal?

YES >> GO TO 4.

NO >> Repair or replace malfunctioning components.

## 4. CHECK TERMINAL

- Check vacuum sensor pin terminals for damage or loose connection with harness connector.
- Check ABS actuator and electric unit (control unit) pin terminals for damage or loose connection with harness connector.

Is the inspection result normal?

YES >> GO TO 5.

NO >> Repair or replace malfunctioning components.

## 5. REPLACE VACUUM SENSOR

Ⓜ With CONSULT

1. Connect ABS actuator and electric unit (control unit) harness connector.
2. Replace vacuum sensor. Refer to [BR-31, "Exploded View"](#).

**CAUTION:**

**Always replace brake booster because vacuum sensor cannot be disassembled.**

3. Erase "Self Diagnostic Result" of "ABS".
4. Turn the ignition switch OFF.
5. Start engine.
6. Perform "Self Diagnostic Result" of "ABS".

Is DTC "C1199" detected?

YES >> Replace ABS actuator and electric unit (control unit). Refer to [BRC-134, "Removal and Installation"](#).

NO >> Inspection End.

# C119A VACUUM SENSOR

< DTC/CIRCUIT DIAGNOSIS >

[VDC/TCS/ABS]

## C119A VACUUM SENSOR

### DTC Logic

INFOID:000000011280637

### DTC DETECTION LOGIC

DTC	Display Item	Malfunction detected condition	Possible causes
C119A	VACUUM SEN VOLT	When a malfunction is detected in supply power voltage of vacuum sensor.	<ul style="list-style-type: none"><li>• Harness or connector</li><li>• Vacuum sensor (brake booster)</li><li>• ABS actuator and electric unit (control unit)</li></ul>

### DTC CONFIRMATION PROCEDURE

#### 1. CHECK SELF DIAGNOSTIC RESULT

 With CONSULT.

1. Turn the ignition switch ON.
2. Perform "Self Diagnostic Result".

Is DTC C119A detected?

- YES >> Proceed to diagnosis procedure. Refer to [BRC-109. "Diagnosis Procedure"](#).  
NO >> Inspection End.

### Diagnosis Procedure

INFOID:000000011280638

Regarding Wiring Diagram information, refer to [BRC-55. "Wiring Diagram"](#).

#### 1. CHECK VACUUM SENSOR POWER SUPPLY

1. Turn the ignition switch OFF.
2. Disconnect vacuum sensor harness connector.
3. Check voltage between vacuum sensor harness connector and ground.

Vacuum sensor		—	Voltage (Approx.)
Connector	Terminal		
E167	3	Ground	0 V

4. Turn the ignition switch ON.  
**CAUTION:**  
**Never start engine.**
5. Check voltage between vacuum sensor harness connector and ground.

Vacuum sensor		—	Voltage (Approx.)
Connector	Terminal		
E167	3	Ground	4.75 V – 5.25 V

Is the inspection result normal?

- YES >> GO TO 3.  
NO >> GO TO 2.

#### 2. CHECK VACUUM SENSOR POWER SUPPLY CIRCUIT

1. Turn the ignition switch OFF.
2. Disconnect ABS actuator and electric unit (control unit) harness connector.
3. Check continuity between vacuum sensor harness connector and ABS actuator and electric unit (control unit) harness connector.

# C119A VACUUM SENSOR

< DTC/CIRCUIT DIAGNOSIS >

[VDC/TCS/ABS]

Vacuum sensor		ABS actuator and electric unit (control unit)		Continuity
Connector	Terminal	Connector	Terminal	
E167	3	E125	5	Yes

4. Check continuity between vacuum sensor harness connector and ground.

Vacuum sensor		—	Continuity
Connector	Terminal		
E167	3	Ground	No

Is the inspection result normal?

YES >> Perform diagnosis of ABS actuator and electric unit (control unit) power supply and ground circuit. Refer to [BRC-109, "Diagnosis Procedure"](#).

NO >> Repair or replace malfunctioning components.

## 3. CHECK VACUUM SENSOR GROUND CIRCUIT

1. Turn the ignition switch OFF.
2. Check continuity between vacuum sensor harness connector and ground.

Vacuum sensor		—	Continuity
Connector	Terminal		
E167	2	Ground	Yes

Is the inspection result normal?

YES >> GO TO 4.

NO >> Repair or replace malfunctioning components.

## 4. CHECK TERMINAL

- Check vacuum sensor pin terminals for damage or loose connection with harness connector.
- Check ABS actuator and electric unit (control unit) pin terminals for damage or loose connection with harness connector.

Is the inspection result normal?

YES >> Replace ABS actuator and electric unit (control unit). Refer to [BRC-134, "Removal and Installation"](#).

NO >> Repair or replace malfunctioning components.

# U1000 CAN COMM CIRCUIT

< DTC/CIRCUIT DIAGNOSIS >

[VDC/TCS/ABS]

## U1000 CAN COMM CIRCUIT

### Description

INFOID:0000000011280639

CAN communication allows a high rate of information transmission through the two communication lines (CAN-H line and CAN-L line) connecting various control units in the system. Each control unit transmits/receives data but selectively reads required data only.

### DTC Logic

INFOID:0000000011280640

### DTC DETECTION LOGIC

DTC	Display Item	Malfunction detected condition	Possible causes
U1000	CAN COMM CIRCUIT	When CAN communication signal is not continuously received for 2 seconds or more.	CAN communication system malfunction

### Diagnosis Procedure

INFOID:0000000011280641

#### 1. CHECK SELF DIAGNOSTIC RESULT

BRC

Ⓜ With CONSULT.

1. Turn ignition switch ON.
2. Perform "Self Diagnostic Result".

Is DTC U1000 detected?

- YES >> Proceed to diagnosis procedure. Refer to [LAN-17, "Trouble Diagnosis Flow Chart"](#).  
NO >> Refer to [GI-44, "Intermittent Incident"](#).

# POWER SUPPLY AND GROUND CIRCUIT

< DTC/CIRCUIT DIAGNOSIS >

[VDC/TCS/ABS]

## POWER SUPPLY AND GROUND CIRCUIT

### Diagnosis Procedure

INFOID:000000011377372

Regarding Wiring Diagram information, refer to [PCS-25. "Wiring Diagram"](#).

### 1. CHECK FUSE AND FUSIBLE LINKS

Check that the following IPDM E/R fuse or fusible links are not blown.

Terminal No.	Signal name	Fuse and fusible link Nos.
1	Battery power supply	D (80A)
2		C (100A)

Is the fuse blown?

- YES >> Replace the blown fuse or fusible link after repairing the affected circuit.  
NO >> GO TO 2.

### 2. CHECK BATTERY POWER SUPPLY CIRCUIT

1. Disconnect IPDM E/R connector E118.
2. Check voltage between IPDM E/R connector E118 and ground.

IPDM E/R		Ground	Voltage (Approx.)
Connector	Terminal		
E118	1	—	Battery voltage
	2		

Is the inspection result normal?

- YES >> GO TO 3.  
NO >> Repair or replace harness or connectors.

### 3. CHECK GROUND CIRCUIT

1. Disconnect IPDM E/R connectors E119, E120 and E121.
2. Check continuity between IPDM E/R connectors and ground.

IPDM E/R		Ground	Continuity
Connector	Terminal		
E119	12	Ground	Yes
E120	31		
E121	47		

Is the inspection result normal?

- YES >> Inspection End.  
NO >> Repair or replace harness or connectors.



# PARKING BRAKE SWITCH

< DTC/CIRCUIT DIAGNOSIS >

[VDC/TCS/ABS]

## PARKING BRAKE SWITCH

### Component Function Check

INFOID:0000000011280643

#### 1. CHECK PARKING BRAKE SWITCH OPERATION

Check that brake warning lamp in combination meter turns ON/OFF when parking brake is operated.

Is the inspection result normal?

- YES >> Inspection End.
- NO >> Proceed to [BRC-113, "Diagnosis Procedure"](#).

### Diagnosis Procedure

INFOID:0000000011280644

#### 1. CHECK PARKING BRAKE SWITCH CIRCUIT

1. Turn the ignition switch OFF.
2. Disconnect parking brake switch harness connector.
3. Disconnect combination meter harness connector.
4. Check the continuity between parking brake switch harness connector and combination meter harness connector.

Parking brake switch		Combination meter		Continuity
Connector	Terminal	Connector	Terminal	
E52	1	M76	26	Yes

5. Check the continuity between parking brake switch harness connector and ground.

Parking brake switch		—	Continuity
Connector	Terminal		
E52	1	Ground	No

Is the inspection result normal?

- YES >> GO TO 2.
- NO >> Repair or replace error-detected parts.

#### 2. CHECK PARKING BRAKE SWITCH

Check the parking brake switch. Refer to [PB-4, "Inspection and Adjustment"](#).

Is the inspection result normal?

- YES >> GO TO 3.
- NO >> Replace the parking brake switch. Refer to [PB-7, "Exploded View"](#).

#### 3. CHECK PARKING BRAKE SWITCH SIGNAL

Ⓜ With CONSULT

1. Connect parking brake switch harness connector.
2. Connect combination meter harness connector.
3. Select "ABS", "Data Monitor" and "PARK BRAKE SW" according to this order. Check the parking brake switch signal.

Condition	DATA MONITOR
Operate parking brake	On
Release the parking brake	Off

Is the inspection result normal?

- YES >> Inspection End.
- NO >> GO TO 4.

#### 4. CHECK COMBINATION METER

Check the combination meter. Refer to [MWI-21, "CONSULT Function \(METER/M&A\)"](#).

# PARKING BRAKE SWITCH

[VDC/TCS/ABS]

< DTC/CIRCUIT DIAGNOSIS >

Is the inspection result normal?

YES >> GO TO 5.

NO >> Repair or replace combination meter. Refer to [MWI-84, "Removal and Installation"](#).

## 5.CHECK TERMINAL

1. Check the combination meter pin terminals for damage or loose connection with harness connector.
2. Check the parking brake switch pin terminals for damage or loose connection with harness connector.

Is the inspection result normal?

YES >> Replace the ABS actuator and electric unit (control unit). Refer to [BRC-134, "Removal and Installation"](#).

NO >> Repair or replace error-detected parts.

## Component Inspection

INFOID:000000011280645

### 1.CHECK PARKING BRAKE SWITCH

1. Turn the ignition switch OFF.
2. Disconnect parking brake switch harness connector.
3. Check the continuity between parking brake switch terminal and ground.

Parking brake switch Terminal	—	Condition	Continuity
1	Ground	When parking brake switch is pressed	Yes
		When parking brake switch is released	No

Is the inspection result normal?

YES >> Inspection End.

NO >> Replace the parking brake switch. Refer to [PB-7, "Exploded View"](#).

# VDC OFF SWITCH

< DTC/CIRCUIT DIAGNOSIS >

[VDC/TCS/ABS]

## VDC OFF SWITCH

### Component Function Check

INFOID:0000000011280646

#### 1.CHECK VDC OFF SWITCH OPERATION

Check that VDC OFF indicator lamp in combination meter turns ON/OFF when VDC OFF switch is operated.

Is the inspection result normal?

- YES >> Inspection End.
- NO >> Proceed to [BRC-115. "Diagnosis Procedure"](#).

### Diagnosis Procedure

INFOID:0000000011280647

#### 1.CHECK VDC OFF SWITCH CIRCUIT

1. Turn the ignition switch OFF.
2. Disconnect ABS actuator and electric unit (control unit) harness connector.
3. Disconnect VDC OFF switch harness connector.
4. Check the continuity between ABS actuator and electric unit (control unit) harness connector and VDC OFF switch harness connector.

ABS actuator and electric unit (control unit)		VDC OFF switch		Continuity
Connector	Terminal	Connector	Terminal	
E125	15	M79	6	Yes

5. Check the continuity between ABS actuator and electric unit (control unit) harness connector and ground.

ABS actuator and electric unit (control unit)		—	Continuity
Connector	Terminal		
E125	15	Ground	No

Is the inspection result normal?

- YES >> GO TO 2.
- NO >> Repair or replace error-detected parts.

#### 2.CHECK VDC OFF SWITCH GROUND CIRCUIT

Check the continuity between VDC OFF switch harness connector and ground.

VDC OFF switch		—	Continuity
Connector	Terminal		
M79	8	Ground	Yes

Is the inspection result normal?

- YES >> GO TO 3.
- NO >> Repair or replace error-detected parts.

#### 3.CHECK VDC OFF SWITCH

Check the VDC OFF switch. Refer to [BRC-116. "Component Inspection"](#).

Is the inspection result normal?

- YES >> GO TO 4.
- NO >> Replace the VDC OFF switch. Refer to [BRC-136. "Removal and Installation"](#).

#### 4.CHECK VDC OFF SWITCH SIGNAL

 With CONSULT

1. Connect ABS actuator and electric unit (control unit) harness connector.
2. Connect VDC OFF switch harness connector.
3. Select "ABS", "Data Monitor" and "OFF SW" according to this order. Check the VDC OFF switch signal.

A  
B  
C  
D  
E  
BRC  
G  
H  
I  
J  
K  
L  
M  
N  
O  
P

# VDC OFF SWITCH

< DTC/CIRCUIT DIAGNOSIS >

[VDC/TCS/ABS]

Condition	DATA MONITOR
When VDC OFF switch is pressed and VDC OFF indicator lamp in combination meter is in ON status	On
When VDC OFF switch is pressed and VDC OFF indicator lamp in combination meter is in OFF status	Off

Is the inspection result normal?

- YES >> Inspection End.  
NO >> GO TO 5.

## 5.CHECK TERMINAL

1. Check the ABS actuator and electric unit (control unit) pin terminals for damage or loose connection with harness connector.
2. Check the VDC OFF switch pin terminals for damage or loose connection with harness connector.

Is the inspection result normal?

- YES >> Replace the ABS actuator and electric unit (control unit). Refer to [BRC-134. "Removal and Installation"](#).  
NO >> Repair or replace error-detected parts.

## Component Inspection

INFOID:0000000011280648

## 1.CHECK VDC OFF SWITCH

1. Turn the ignition switch OFF.
2. Disconnect VDC OFF switch harness connector.
3. Check the continuity between terminals of VDC OFF switch connector.

VDC OFF switch	Condition	Continuity
Terminal		
6- 8	When VDC OFF switch is pressed	Yes
	When VDC OFF switch is not pressed	No

Is the inspection result normal?

- YES >> Inspection End.  
NO >> Replace the VDC OFF switch. Refer to [BRC-136. "Removal and Installation"](#).

&lt; DTC/CIRCUIT DIAGNOSIS &gt;

## ABS WARNING LAMP

## Component Function Check

INFOID:0000000011280649

## 1. CHECK ABS WARNING LAMP FUNCTION

Check that ABS warning lamp in combination meter turns ON for 1 second after ignition switch is turned ON.

**CAUTION:****Never start the engine.**

Is the inspection result normal?

YES &gt;&gt; Inspection End.

NO >> Proceed to [BRC-117, "Diagnosis Procedure"](#).

## Diagnosis Procedure

INFOID:0000000011280650

## 1. CHECK ABS ACTUATOR AND ELECTRIC UNIT (CONTROL UNIT) POWER SUPPLY AND GROUND CIRCUIT

Perform the trouble diagnosis for ABS actuator and electric unit (control unit) power supply and ground circuit. Refer to [BRC-117, "Diagnosis Procedure"](#).

Is the inspection result normal?

YES &gt;&gt; GO TO 2.

NO &gt;&gt; Repair or replace error-detected parts.

## 2. PERFORM SELF DIAGNOSTIC

④ With CONSULT

1. Turn the ignition switch OFF → ON.

**CAUTION:**

- Be sure to wait of 10 seconds after turning ignition switch OFF or ON.
- Start the engine.

2. Repeat step 1 two or more times.

3. Perform "Self Diagnostic Result" of "ABS".

Is any DTC detected?

YES >> Check the DTC. Refer to [BRC-53, "DTC Index"](#).

NO &gt;&gt; GO TO 3.

## 3. CHECK ABS WARNING LAMP SIGNAL

④ With CONSULT

1. Select "ABS", "Data Monitor" and "ABS WARN LAMP" according to this order.

2. Turn the ignition switch OFF.

3. Check that data monitor displays "On" for 1 second after ignition switch is turned ON and then changes to "Off".

**CAUTION:****Never start the engine.**

Is the inspection result normal?

YES >> Replace the combination meter. Refer to [MWI-84, "Removal and Installation"](#).NO >> Replace the ABS actuator and electric unit (control unit). Refer to [BRC-134, "Removal and Installation"](#).

## BRAKE WARNING LAMP

## Component Function Check

INFOID:0000000011280651

**1.**CHECK BRAKE WARNING LAMP FUNCTION

Check that brake warning lamp in combination meter turns ON for 1 second after ignition switch is turned ON.

**CAUTION:**

**Never start the engine.**

Is the inspection result normal?

YES >> GO TO 2.

NO >> Proceed to [BRC-118, "Diagnosis Procedure"](#).

**2.**CHECK BRAKE WARNING LAMP FUNCTION

Check that brake warning lamp turns ON/OFF when parking brake is operated.

**NOTE:**

Brake warning lamp turns ON when parking brake is operated (when parking brake switch is ON).

Is the inspection result normal?

YES >> GO TO 3.

NO >> Check the parking brake switch system. Refer to [BRC-113, "Diagnosis Procedure"](#).

**3.**CHECK BRAKE WARNING LAMP FUNCTION

Check that brake warning lamp in combination meter turns ON/OFF when brake fluid level switch is operated while brake fluid level in reservoir tank is with the specified level.

**NOTE:**

Brake warning lamp turns ON when brake fluid is less than the specified level (when brake fluid level switch is ON).

Is the inspection result normal?

YES >> Inspection End.

NO >> Check the brake fluid level switch system. Refer to [BR-28, "Exploded View"](#).

## Diagnosis Procedure

INFOID:0000000011280652

**1.**CHECK ABS ACTUATOR AND ELECTRIC UNIT (CONTROL UNIT) POWER SUPPLY AND GROUND CIRCUIT

Perform the trouble diagnosis for ABS actuator and electric unit (control unit) power supply and ground circuit. Refer to [BRC-118, "Diagnosis Procedure"](#).

Is the inspection result normal?

YES >> GO TO 2.

NO >> Repair or replace error-detected parts.

**2.**PERFORM THE SELF DIAGNOSTIC

 With CONSULT

1. Turn the ignition switch OFF → ON.

**CAUTION:**

- Be sure to wait of 10 seconds after turning ignition switch OFF or ON.
- Start the engine.

2. Repeat step 1 two or more times.

3. Perform "Self Diagnostic Result" of "ABS".

Is any DTC detected?

YES >> Check the DTC. Refer to [BRC-53, "DTC Index"](#).

NO >> GO TO 3.

**3.**CHECK BRAKE WARNING LAMP SIGNAL

 With CONSULT

1. Select "ABS", "Data Monitor" and "EBD WARN LAMP" according to this order.

2. Turn the ignition switch OFF.

# BRAKE WARNING LAMP

< DTC/CIRCUIT DIAGNOSIS >

[VDC/TCS/ABS]

3. Check that data monitor displays “On” for 1 second after ignition switch is turned ON and then changes to “Off”.

**CAUTION:**

**Never start the engine.**

Is the inspection result normal?

- YES >> Replace the combination meter. Refer to [MWI-84, "Removal and Installation"](#).  
NO >> Replace the ABS actuator and electric unit (control unit). Refer to [BRC-134, "Removal and Installation"](#).

A  
B  
C  
D  
E  
G  
H  
I  
J  
K  
L  
M  
N  
O  
P

**BRC**

## VDC WARNING LAMP

## Component Function Check

INFOID:000000011280653

**1.**CHECK VDC WARNING LAMP FUNCTION

Check that VDC warning lamp in combination meter turns ON for 1 second after ignition switch is turned ON.

**CAUTION:**

**Never start the engine.**

Is the inspection result normal?

- YES >> Inspection End.  
 NO >> Proceed to [BRC-120, "Diagnosis Procedure"](#).

## Diagnosis Procedure

INFOID:000000011280654

**1.**CHECK ABS ACTUATOR AND ELECTRIC UNIT (CONTROL UNIT) POWER SUPPLY AND GROUND CIRCUIT

Perform the trouble diagnosis for ABS actuator and electric unit (control unit) power supply and ground circuit. Refer to [BRC-120, "Diagnosis Procedure"](#).

Is the inspection result normal?

- YES >> GO TO 2.  
 NO >> Repair or replace error-detected parts.

**2.**PERFORM THE SELF DIAGNOSTIC

 With CONSULT

1. Turn the ignition switch OFF → ON.

**CAUTION:**

- **Be sure to wait of 10 seconds after turning ignition switch OFF or ON.**
- **Start the engine.**

2. Repeat step 1 two or more times.  
 3. Perform "Self Diagnostic Result" of "ABS".

Is any DTC detected?

- YES >> Check the DTC. Refer to [BRC-53, "DTC Index"](#).  
 NO >> GO TO 3.

**3.**CHECK VDC WARNING LAMP SIGNAL

 With CONSULT

1. Select "ABS", "Data Monitor" and "SLIP/VDC LAMP" according to this order.  
 2. Turn the ignition switch OFF.  
 3. Check that data monitor displays "On" for approx. 1 second after ignition switch is turned ON, and then changes to "Off".

**CAUTION:**

**Never start the engine.**

Is the inspection result normal?

- YES >> Replace the combination meter. Refer to [MWI-84, "Removal and Installation"](#).  
 NO >> Replace the ABS actuator and electric unit (control unit). Refer to [BRC-134, "Removal and Installation"](#).



# VDC OFF INDICATOR LAMP

< DTC/CIRCUIT DIAGNOSIS >

[VDC/TCS/ABS]

## VDC OFF INDICATOR LAMP

### Component Function Check

INFOID:000000011280655

#### 1. CHECK VDC OFF INDICATOR LAMP FUNCTION (1)

Check that VDC OFF indicator lamp in combination meter turns ON for 1 second after ignition switch is turned ON.

**CAUTION:**

**Never start the engine.**

Is the inspection result normal?

YES >> GO TO 2.

NO >> Proceed to [BRC-121, "Diagnosis Procedure"](#).

#### 2. CHECK VDC OFF INDICATOR LAMP FUNCTION (2)

Check that VDC OFF indicator lamp in combination meter turns ON/OFF when VDC OFF switch is operated.

Is the inspection result normal?

YES >> Inspection End.

NO >> Check the VDC OFF switch system. Refer to [BRC-115, "Diagnosis Procedure"](#).

### Diagnosis Procedure

INFOID:000000011280656

#### 1. CHECK ABS ACTUATOR AND ELECTRIC UNIT (CONTROL UNIT) POWER SUPPLY AND GROUND CIRCUIT

Perform the trouble diagnosis for ABS actuator and electric unit (control unit) power supply and ground circuit. Refer to [BRC-121, "Diagnosis Procedure"](#).

Is the inspection result normal?

YES >> GO TO 2.

NO >> Repair or replace error-detected parts.

#### 2. CHECK VDC OFF INDICATOR LAMP SIGNAL

Ⓜ With CONSULT

1. Select "ABS", "Data Monitor" and "OFF LAMP" according to this order.

2. Turn the ignition switch OFF.

3. Check that data monitor displays "On" for 1 second after ignition switch is turned ON, and then changes to "Off".

**CAUTION:**

**Never start the engine.**

Is the inspection result normal?

YES >> GO TO 3.

NO >> Replace the ABS actuator and electric unit (control unit). Refer to [BRC-134, "Removal and Installation"](#).

#### 3. CHECK VDC OFF INDICATOR LAMP SIGNAL

Ⓜ With CONSULT

1. Select "ABS", "Data Monitor" and "OFF LAMP" according to this order.

2. Check that data monitor displays "On" or "Off" each time when VDC OFF switch is operated.

Is the inspection result normal?

YES >> Replace the combination meter. Refer to [MWI-84, "Removal and Installation"](#).

NO >> Check the VDC OFF switch system. Refer to [BRC-115, "Diagnosis Procedure"](#).

# SYMPTOM DIAGNOSIS

## EXCESSIVE OPERATION FREQUENCY

### Description

INFOID:0000000011280657

VDC function, TCS function, ABS function, EBD function, Brake limited slip differential (BLSD) function, Brake assist function, hill start assist function or Brake force distribution function operates in excessive operation frequency.

### Diagnosis Procedure

INFOID:0000000011280658

#### 1. CHECK BRAKING FORCE

Check brake force using a brake tester.

Is the inspection result normal?

YES >> GO TO 2.

NO >> Check brake system.

#### 2. CHECK FRONT AND REAR AXLE

Check that there is no excessive looseness in front and rear axle.

- 2WD: Refer to [FAX-7, "Inspection"](#) (front) or [RAX-6, "Inspection"](#) (rear).
- AWD: Refer to [FAX-45, "Inspection"](#) (front) or [RAX-14, "Inspection"](#) (rear).

Is the inspection result normal?

YES >> GO TO 3.

NO >> Repair or replace error-detected parts.

#### 3. CHECK WHEEL SENSOR

Check wheel sensor.

- Check installation and damage of wheel sensor.
- Check connection of wheel sensor harness connector.
- Check terminal of wheel sensor harness connector.

Is the inspection result normal?

YES >> GO TO 4.

NO >> Repair installation or replace wheel sensor.

- Front wheel sensor: Refer to [BRC-130, "FRONT WHEEL SENSOR : Removal and Installation"](#).
- Rear wheel sensor: Refer to [BRC-132, "REAR WHEEL SENSOR : Removal and Installation"](#).

#### 4. CHECK SENSOR ROTOR

Check that there is no looseness, damage or foreign material on sensor rotor.

Is the inspection result normal?

YES >> GO TO 5.

NO >> Repair installation or replace sensor rotor.

- Front sensor rotor: Refer to [BRC-133, "FRONT SENSOR ROTOR : Removal and Installation - Front Sensor Rotor"](#).
- Rear sensor rotor: Refer to [BRC-133, "REAR SENSOR ROTOR : Removal and Installation - Rear Sensor Rotor"](#).

#### 5. CHECK WARNING LAMP TURNS OFF

Check that ABS warning lamp, brake warning lamp and VDC warning lamp turn OFF approx. 1 second after key switch is turned ON and stay in OFF status during driving.

**CAUTION:**

**Brake warning lamp turns ON when parking brake is operated (parking brake switch is ON) or brake fluid is less than the specified level (brake fluid level switch is ON).**

Is the inspection result normal?

YES >> Normal

NO >> GO TO 6.

#### 6. PERFORM THE SELF DIAGNOSTIC

# EXCESSIVE OPERATION FREQUENCY

< SYMPTOM DIAGNOSIS >

[VDC/TCS/ABS]

④ With CONSULT

1. Turn the ignition switch OFF → ON.

**CAUTION:**

- Be sure to wait of 10 seconds after turning ignition switch OFF or ON.
- Set the vehicle to READY/Start the engine.

2. Repeat step 1 two or more times.

3. Perform "Self Diagnostic Result" of "ABS".

Is any DTC detected?

YES >> Check the DTC. Refer to [BRC-53, "DTC Index"](#).

NO >> Inspection End.

A

B

C

D

E

BRC

G

H

I

J

K

L

M

N

O

P

# UNEXPECTED BRAKE PEDAL REACTION

< SYMPTOM DIAGNOSIS >

[VDC/TCS/ABS]

## UNEXPECTED BRAKE PEDAL REACTION

### Description

INFOID:000000011280659

A malfunction of brake pedal feel (height or others) is detected when brake pedal is depressed.

### Diagnosis Procedure

INFOID:000000011280660

#### 1.CHECK FRONT AND REAR AXLE

Check that there is no excessive looseness in front and rear axle.

- 2WD: Refer to [FAX-7. "Inspection"](#) (front) or [RAX-6. "Inspection"](#) (rear).
- AWD: Refer to [FAX-45. "Inspection"](#) (front) or [RAX-14. "Inspection"](#) (rear).

Is the inspection result normal?

- YES >> GO TO 2.
- NO >> Repair or replace error-detected parts.

#### 2.CHECK DISC ROTOR

Check disc rotor runout.

- Front: Refer to [BR-11. "DISC BRAKE ROTOR : Inspection"](#).
- Rear: Refer to [BR-13. "DISC BRAKE ROTOR : Inspection"](#).

Is the inspection result normal?

- YES >> GO TO 3.
- NO >> Refinish the disc rotor.

#### 3.CHECK BRAKE FLUID LEAKAGE

Check fluid leakage.

Refer to [BR-8. "Inspection"](#)

Is the inspection result normal?

- YES >> GO TO 4.
- NO >> Repair or replace error-detected parts.

#### 4.CHECK BRAKE PEDAL

Check each item of brake pedal. Refer to [BR-15. "Adjustment"](#).

Is the inspection result normal?

- YES >> GO TO 5.
- NO >> Adjust each item of brake pedal. Refer to [BR-15. "Adjustment"](#).

#### 5.CHECK BRAKING FORCE

Check brake force using a brake tester.

Is the inspection result normal?

- YES >> GO TO 6.
- NO >> Check each components of brake system.

#### 6.CHECK BRAKE PERFORMANCE

Disconnect ABS actuator and electric unit (control unit) connector so that ABS does not operate. Check that brake force is normal in this condition. Connect harness connectors after checking.

Is the inspection result normal?

- YES >> Normal
- NO >> Check each components of brake system.

# THE BRAKING DISTANCE IS LONG

< SYMPTOM DIAGNOSIS >

[VDC/TCS/ABS]

## THE BRAKING DISTANCE IS LONG

### Description

INFOID:0000000011280661

Brake stopping distance is long when ABS function is operated.

### Diagnosis Procedure

INFOID:0000000011280662

#### **CAUTION:**

**Brake stopping distance on slippery road like rough road, gravel road or snowy road may become longer when ABS is operated than when ABS is not operated.**

#### **1.CHECK BRAKING FORCE**

Check brake force using a brake tester.

Is the inspection result normal?

YES >> GO TO 2.

NO >> Check each components of brake system.

#### **2.CHECK BRAKE PERFORMANCE**

Disconnect ABS actuator and electric unit (control unit) connector so that ABS does not operate. Check brake stopping distance in this condition. Connect harness connectors after checking.

Is the inspection result normal?

YES >> Normal

NO >> Check each components of brake system.

A  
B  
C  
D  
E  
BRC  
G  
H  
I  
J  
K  
L  
M  
N  
O  
P

## DOES NOT OPERATE

## Description

INFOID:000000011280663

VDC function, TCS function, ABS function, EBD function, Brake limited slip differential (BLSD) function, Brake assist function, hill start assist function or Brake force distribution function does not operate.

## Diagnosis Procedure

INFOID:000000011280664

**CAUTION:**

- VDC function, TCS function, ABS function, EBD function, Brake limited slip differential (BLSD) function, Brake assist function, hill start assist function and Brake force distribution function never operate when the vehicle speed is 10 km/h (6.2 MPH) or less. However, TCS function, Brake limited slip differential (BLSD) function and hill start assist function operates when the vehicle speed is 0 km/h (0 MPH) (the vehicle is in stop status).
- VDC function and TCS function never operate when VDC OFF switch is operated (when VDC OFF indicator lamp turns ON).

**1**.CHECK ABS WARNING LAMP

Check that ABS warning lamp, brake warning lamp and VDC warning lamp turn ON and turn OFF approx. 1 second after key switch is turned ON. Check that ABS warning lamp, brake warning lamp and VDC warning lamp and stay in OFF status during driving.

**CAUTION:**

Brake warning lamp turns ON when parking brake is operated (parking brake switch is ON) or brake fluid is less than the specified level (brake fluid level switch is ON).

Is the inspection result normal?

- YES >> Normal  
NO >> GO TO 2.

**2**.PERFORM SELF DIAGNOSTIC

 With CONSULT

1. Turn the ignition switch OFF → ON.

**CAUTION:**

- Be sure to wait of 10 seconds after turning ignition switch OFF or ON.
- Start the engine.

2. Repeat step 1 two or more times.
3. Perform "Self Diagnostic Result" of "ABS" with CONSULT.

Is any DTC detected?

- YES >> Check the DTC. Refer to [BRC-53, "DTC Index"](#).  
NO >> Inspection End.

# BRAKE PEDAL VIBRATION OR OPERATION SOUND OCCURS

< SYMPTOM DIAGNOSIS >

[VDC/TCS/ABS]

## BRAKE PEDAL VIBRATION OR OPERATION SOUND OCCURS

### Description

INFOID:0000000011280665

- Brake pedal vibrates and motor sound from ABS actuator and electric unit (control unit) occurs, when the engine starts.
- Brake pedal vibrates during braking.

#### **CAUTION:**

Vibration may be felt during brake pedal is lightly depressed (just placing a foot on it) in the following conditions. This is normal.

- When shifting gears
- When driving on slippery road
- During cornering at high speed
- When passing over bumps or grooves [Approx. 50 mm (1.97 in) or more]
- When pulling away just after starting engine [at approx. 10 km/h (6.2 MPH) or higher]

### Diagnosis Procedure

INFOID:0000000011280666

#### 1. SYMPTOM CHECK 1

Check that there are pedal vibrations when the engine is started.

Do vibrations occur?

YES >> GO TO 2.

NO >> Check brake pedal. Refer to [BR-15. "Adjustment"](#).

#### 2. SYMPTOM CHECK 2

Check that motor sound from ABS actuator occurs when the engine starts.

Does the operation sound occur?

YES >> GO TO 3.

NO >> Perform "Self Diagnostic Result" of "ABS" with CONSULT.

#### 3. SYMPTOM CHECK 3

Check symptoms when electrical component (headlamps, etc.) switches are operated.

Does the symptom occur?

YES >> Check that radio (including wiring), antenna and antenna lead-in wires are not located near ABS actuator and electric unit (control unit). Move them if they are located near ABS actuator and electric unit (control unit).

NO >> GO TO 4.

#### 4. PERFORM SELF DIAGNOSTIC RESULT

 With CONSULT

1. Turn the ignition switch OFF → ON.

#### **CAUTION:**

- Be sure to wait of 10 seconds after turning ignition switch OFF or ON.
- Start the engine.

2. Repeat step 1 two or more times.

3. Perform "Self Diagnostic Result" of "ABS".

Is any DTC detected?

YES >> Check the DTC. Refer to [BRC-53. "DTC Index"](#).

NO >> Inspection End.

A  
B  
C  
D  
E  
G  
H  
I  
J  
K  
L  
M  
N  
O  
P

BRC

## VEHICLE JERKS DURING

## Description

INFOID:000000011280667

The vehicle jerks when VDC function, TCS function, ABS function, EBD function, Brake limited slip differential (BLSD) function, Brake assist function, hill start assist function or Brake force distribution function operates.

## Diagnosis Procedure

INFOID:000000011280668

## 1. CHECK SYMPTOM

Check that the vehicle jerks when VDC function, TCS function, ABS function, EBD function, Brake limited slip differential (BLSD) function, Brake assist function, hill start assist function or Brake force distribution function operates.

Is the inspection result normal?

- YES >> Normal  
NO >> GO TO 2.

## 2. PERFORM THE SELF DIAGNOSTIC RESULT

## ④ With CONSULT

1. Turn the ignition switch OFF → ON.

**CAUTION:**

- Be sure to wait of 10 seconds after turning ignition switch OFF or ON.
- Start the engine.

2. Repeat step 1 two or more times.
3. Perform "Self Diagnostic Result" of "ABS".

Is any DTC detected?

- YES >> Check the DTC. Refer to [BRC-53, "DTC Index"](#).  
NO >> GO TO 3.

## 3. CHECK CONNECTOR

## ④ With CONSULT

1. Turn the ignition switch OFF.
2. Disconnect ABS actuator and electric unit (control unit) harness connector.
3. Check connector terminal for deformation, disconnection and looseness.

Is the inspection result normal?

- YES >> GO TO 4.  
NO >> Poor connection of connector terminal. Repair or replace connector terminal.

## 4. PERFORM THE SELF DIAGNOSTIC RESULT

## ④ With CONSULT

1. Connect harness connector.
2. Turn the ignition switch OFF → ON.

**CAUTION:**

- Be sure to wait of 10 seconds after turning ignition switch OFF or ON.
- Start the engine.

3. Repeat step 2 two or more times.
4. Perform "Self Diagnostic Result" of "ABS".

Is any DTC detected?

- YES >> Check the DTC. Refer to [BRC-53, "DTC Index"](#).  
NO >> GO TO 5.

## 5. PERFORM THE SELF DIAGNOSTIC RESULT

## ④ With CONSULT

Perform "Self Diagnostic Result" of "ENGINE", "TRANSMISSION".

Is any DTC detected?

- YES >> Check the DTC.  
NO >> Replace ABS actuator and electric unit (control unit). Refer to [BRC-134, "Removal and Installation"](#).



# NORMAL OPERATING CONDITION

< SYMPTOM DIAGNOSIS >

[VDC/TCS/ABS]

## NORMAL OPERATING CONDITION

### Description

INFOID:0000000011280669

Symptom	Result
Brake pedal slightly vibrates and operation sound (motor sound and sound from suspension) occurs when VDC function, TCS function, ABS function, EBD function, Brake limited slip differential (BLSD) function, Brake assist function, hill start assist function or Brake force distribution function operates.	This is not a malfunction, because it is caused by VDC function, TCS function, ABS function, EBD function, Brake limited slip differential (BLSD) function, Brake assist function, hill start assist function and Brake force distribution function that are normally operated.
Brake stopping distance may become longer than models without ABS function depending on the road conditions, when ABS function is operated on slippery road like rough road, gravel road or snowy road.	
Brake pedal vibrates and operation sound occurs during sudden acceleration and cornering, when VDC function, TCS function, Brake assist function or Brake force distribution function is operated.	
Brake pedal vibrates and motor sound from the engine room occurs, when the engine starts or the vehicle starts just after starting the engine.	This is not a malfunction, because it is caused by operation check of ABS actuator and electric unit (control unit).
Acceleration may be felt insufficient depending on the road conditions.	This is not a malfunction, because it is caused by TCS function that puts the highest priority to obtain the optimum traction (stability).
TCS function may operate momentarily, while driving on a road where friction coefficient varies, or when downshifting, or fully depressing accelerator pedal.	
ABS warning lamp and VDC OFF indicator lamp may turn ON, when the vehicle is on a rotating turntable or is given a strong shaking or large vibrations on a ship while the engine is running.	In this case, restart the engine on a normal road. If the normal condition is restored, there is no malfunction. In that case, erase "ABS" self-diagnosis result memory with CONSULT.
VDC warning lamp may turn ON and VDC function, TCS function, Brake assist function, and Brake force distribution function may not normally operate, when driving on a special road the is extremely slanted (bank in a circuit course).	
A malfunction in yaw rate/side/decel G sensor system may be detected when the vehicle sharply turns during a spin turn, acceleration turn or drift driving while VDC function, TCS function, are OFF (VDC OFF switch is pressed and VDC OFF indicator lamp is in ON status).	
The vehicle speed does not increase, when the accelerator pedal is depressed while the vehicle is on a 2-wheel chassis dynamometer for speedometer check.	This is normal. (When checking the vehicle on a chassis dynamometer, operate VDC OFF switch so that TCS function is OFF.)

A  
B  
C  
D  
E  
**BRC**  
G  
H  
I  
J  
K  
L  
M  
N  
O  
P

# WHEEL SENSOR

< REMOVAL AND INSTALLATION >

[VDC/TCS/ABS]

## REMOVAL AND INSTALLATION

### WHEEL SENSOR

#### FRONT WHEEL SENSOR

#### FRONT WHEEL SENSOR : Exploded View

INFOID:000000011280670

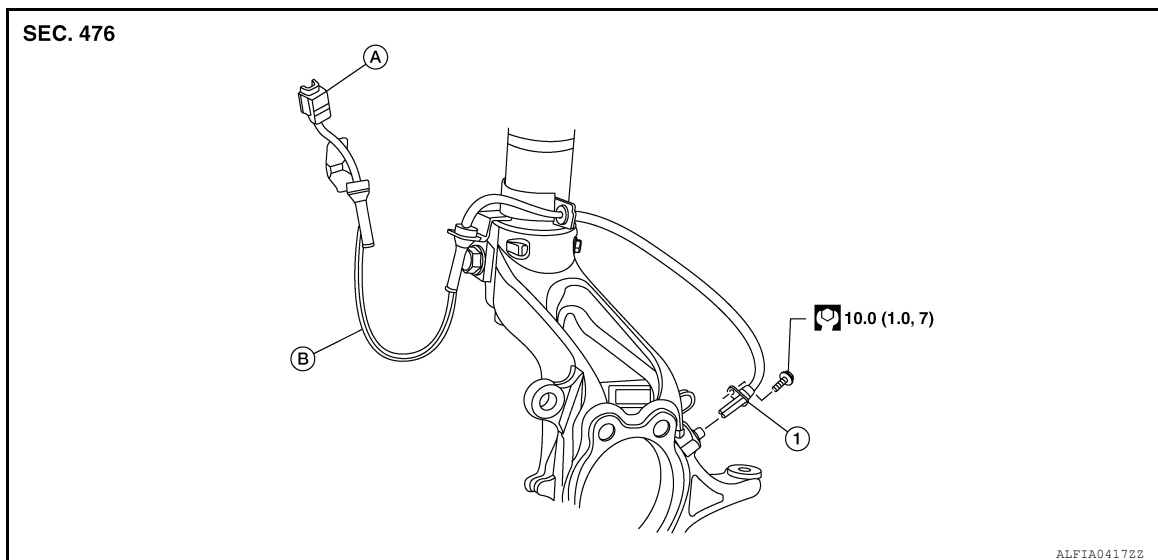

1. Front LH wheel sensor

A. Harness connector

B. Slant line

#### FRONT WHEEL SENSOR : Removal and Installation

INFOID:000000011280671

#### CAUTION:

- Be careful not to damage front wheel sensor edge and sensor rotor teeth.
- When removing the front wheel hub and bearing, first remove the front wheel sensor from the steering knuckle. Failure to do so may result in damage to the front wheel sensor wires making the front wheel sensor inoperative.
- Pull out the front wheel sensor, being careful to turn it as little as possible. Do not pull on the front wheel sensor harness.
- Before installation, check if foreign objects such as iron fragments are adhered to the pick-up part of the front wheel sensor or to the inside of the hole in the steering knuckle for the front wheel sensor, or if a foreign object is caught in the surface of the sensor rotor. Fix as necessary and then install the front wheel sensor.

#### REMOVAL

1. Remove the front wheel and tire using power tool. Refer to [WT-64, "Adjustment"](#).
2. Partially remove the fender protector to gain access to the wheel sensor harness connector. Refer to [EXT-28, "FENDER PROTECTOR : Exploded View"](#).
3. Disconnect the harness connector from the front wheel sensor.
4. Remove the front wheel sensor bolt from the wheel hub and bearing.
5. Remove the front wheel sensor from the strut bracket.
6. Remove the front wheel sensor from the steering knuckle.

#### INSTALLATION

Installation is in the reverse order of removal.

#### CAUTION:

- When installing, make sure there is no foreign material such as iron chips on and in the hole in the steering knuckle for the front wheel sensor. Make sure no foreign material has been caught in the sensor rotor. Remove any foreign material and clean the mount.

# WHEEL SENSOR

< REMOVAL AND INSTALLATION >

[VDC/TCS/ABS]

- Do not twist front wheel sensor harness when installing front wheel sensor. Check that grommet (2) is fully inserted to bracket (1). Check that front wheel sensor harness is not twisted after installation.

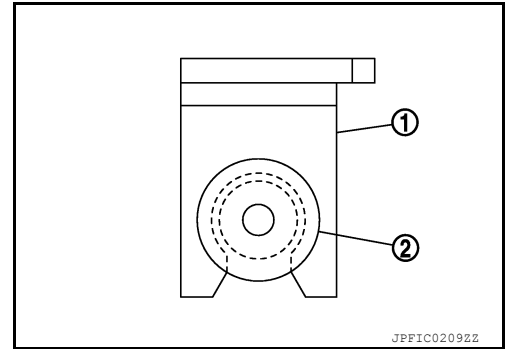

## REAR WHEEL SENSOR

### REAR WHEEL SENSOR : Exploded View

INFOID:0000000011280672

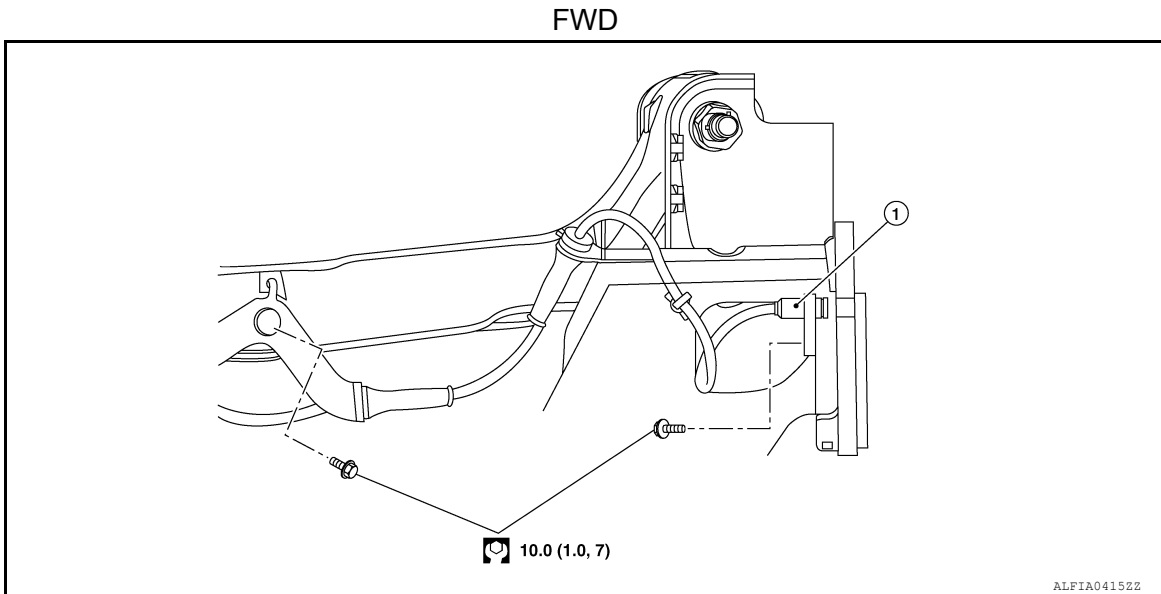

1. Rear LH wheel sensor

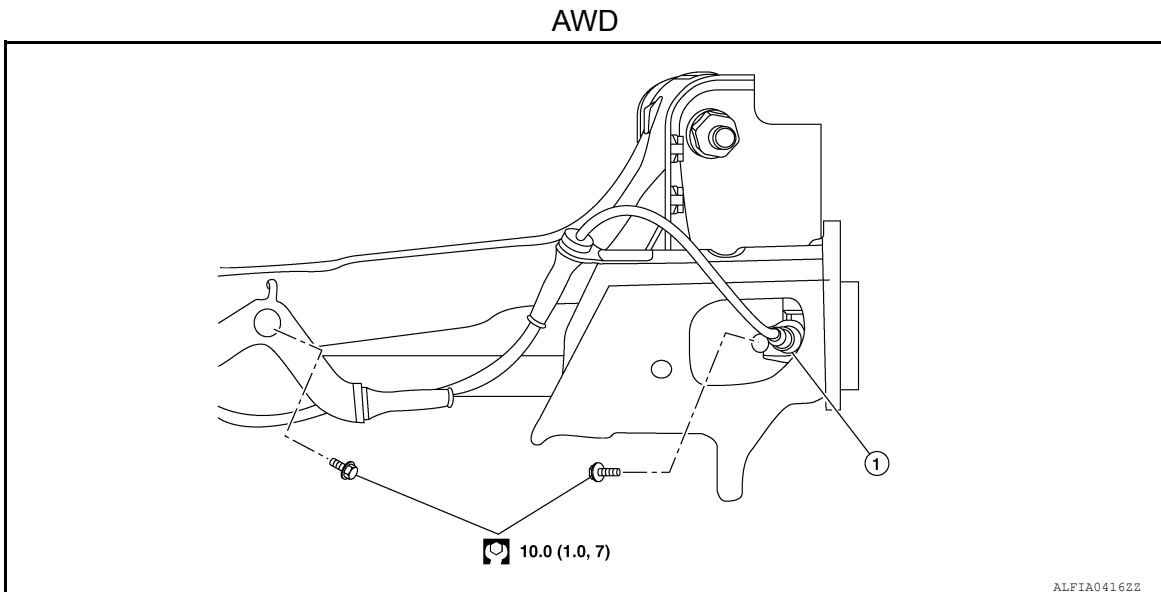

1. Rear LH wheel sensor

A  
B  
C  
D  
E  
BRC  
G  
H  
I  
J  
K  
L  
M  
N  
O  
P

# WHEEL SENSOR

< REMOVAL AND INSTALLATION >

[VDC/TCS/ABS]

## REAR WHEEL SENSOR : Removal and Installation

INFOID:000000011280673

### CAUTION:

- Be careful not to damage rear wheel sensor edge and sensor rotor teeth.
- When removing the rear wheel hub and bearing, first remove the rear wheel sensor from the rear wheel hub and bearing (FWD) or the rear axle housing (AWD). Failure to do so may result in damage to the rear wheel sensor making the rear wheel sensor inoperative.
- Pull out the rear wheel sensor, being careful to turn it as little as possible. Do not pull on the rear wheel sensor harness.
- Before installation, check if foreign objects such as iron fragments are adhered to the pick-up part of the rear wheel sensor or to the inside of the hole in the rear wheel hub and bearing (FWD) or the rear axle housing (AWD) for the rear wheel sensor, or if a foreign object is caught in the surface of the sensor rotor. Fix as necessary and then install the rear wheel sensor.

### REMOVAL

1. Remove the rear wheel and tire using power tool. Refer to [WT-64, "Adjustment"](#).
2. Remove the rear wheel sensor bolt.
3. Disconnect the harness connector from the rear wheel sensor.
4. Remove the rear wheel sensor from the wheel hub and bearing (FWD) or the rear axle housing (AWD).
5. Remove the rear wheel sensor harness grommet from the bracket.
6. Remove the bolt, the rear wheel sensor harness, and the rear wheel sensor from the bracket.

### INSTALLATION

Installation is in the reverse order of removal.

### CAUTION:

- When installing, make sure there is no foreign material such as iron chips on and in the hole in the rear wheel hub and bearing (FWD) or the rear axle housing (AWD) for the rear wheel sensor. Make sure no foreign material has been caught in the sensor rotor. Remove any foreign material and clean the mount.
- Do not twist rear wheel sensor harness when installing rear wheel sensor. Check that grommet (2) is fully inserted to bracket (1). Check that rear wheel sensor harness is not twisted after installation.

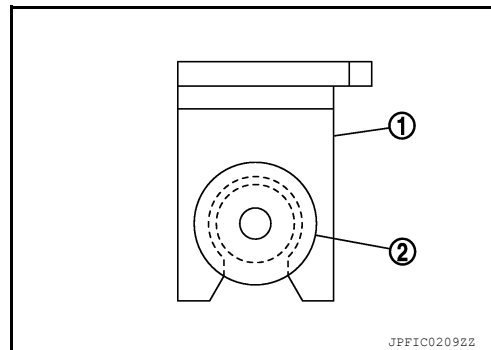

# SENSOR ROTOR

< REMOVAL AND INSTALLATION >

[VDC/TCS/ABS]

## SENSOR ROTOR

### FRONT SENSOR ROTOR

#### FRONT SENSOR ROTOR : Removal and Installation - Front Sensor Rotor INFOID:0000000011280674

The front wheel sensor rotor is an integral part of the wheel hub and bearing and cannot be disassembled. Refer to [FAX-9. "Removal and Installation"](#) (FWD) or [FAX-47. "Removal and Installation"](#) (AWD).

### REAR SENSOR ROTOR

#### REAR SENSOR ROTOR : Removal and Installation - Rear Sensor Rotor INFOID:0000000011280675

For FWD vehicles, the rear wheel sensor rotor is an integral part of the wheel hub and bearing and cannot be disassembled. Refer to [RAX-7. "Removal and Installation"](#) (FWD).

For AWD vehicles, the rear wheel sensor rotor is pressed on the rear drive shaft and can be disassembled. Refer to [RAX-21. "Disassembly and Assembly"](#) (AWD).

A  
B  
C  
D  
E  
G  
H  
I  
J  
K  
L  
M  
N  
O  
P

**BRC**

# ABS ACTUATOR AND ELECTRIC UNIT (CONTROL UNIT)

< REMOVAL AND INSTALLATION >

[VDC/TCS/ABS]

## ABS ACTUATOR AND ELECTRIC UNIT (CONTROL UNIT)

Exploded View

INFOID:000000011280676

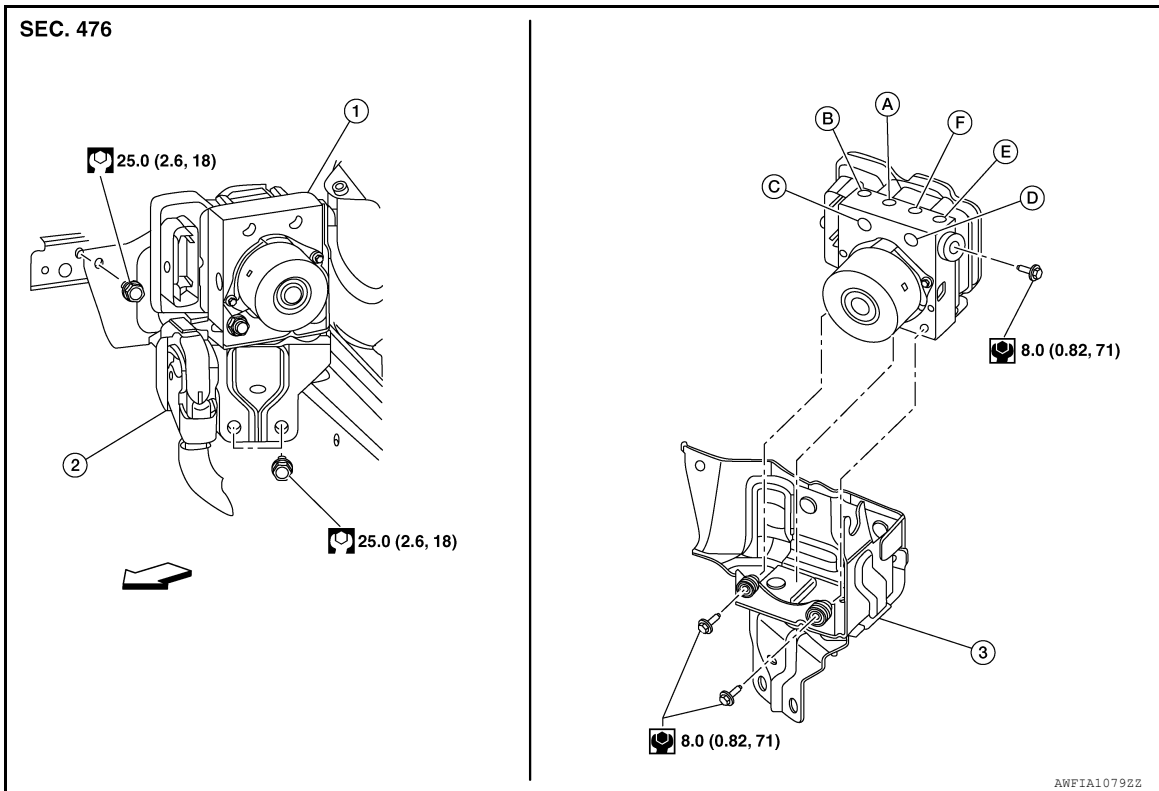

- |  |                             |  |
|--|-----------------------------|--|
| 1. ABS actuator and electric unit (control unit) | 2. Connector                | 3. Bracket                             |
| A. To front LH brake caliper                     | B. To rear RH brake caliper | C. From master cylinder secondary side |
| D. From master cylinder primary side             | E. To rear LH brake caliper | F. To front RH brake caliper           |

## Removal and Installation

INFOID:000000011280677

### REMOVAL

#### CAUTION:

- To remove brake tube, use a flare nut wrench to prevent flare nuts and brake tube from being damaged.
- Do not remove actuator by holding harness.

#### NOTE:

When removing components such as hoses, tubes/lines, etc., cap or plug openings to prevent fluid from spilling.

1. Disconnect negative battery terminal. Refer to [PG-78, "Exploded View"](#).
2. Remove the cowl top cover and cowl top extension. Refer to [EXT-25, "Removal and Installation"](#).
3. Separate brake tubes from ABS actuator and electric unit (control unit). Refer to [BR-22, "FRONT : Exploded View"](#).
4. Remove the brake booster vacuum hose. Refer to [BR-33, "Removal and Installation"](#).
5. Separate the brake booster vacuum tube and place aside. Refer to [BR-23, "FRONT : Removal and Installation"](#).
6. Disconnect the harness connector from the ABS actuator and electric unit (control unit).
7. Remove ABS actuator and electric unit (control unit) bracket bolts and bushings.
8. Remove ABS actuator and electric unit (control unit) from vehicle.

### INSTALLATION

Installation is in the reverse order of removal.

# ABS ACTUATOR AND ELECTRIC UNIT (CONTROL UNIT)

< REMOVAL AND INSTALLATION >

[VDC/TCS/ABS]

- After work is completed, bleed air from brake tube. Refer to [BR-16. "Bleeding Brake System"](#).
- Adjust the neutral position of steering angle sensor. Refer to [BRC-68. "Work Procedure"](#).
- Perform calibration of the decel G sensor. Refer to [BRC-70. "Work Procedure"](#).

A

**CAUTION:**

- **To install, use flare nut crowfoot and torque wrench.**
- **Do not reuse the bushings.**
- **Replace the ABS actuator if it has been dropped or sustained an impact.**
- **Do not install actuator by holding harness.**
- **After installing harness connector in the ABS actuator and electric unit (control unit), make sure connector is securely locked.**

B

C

D

E

**BRC**

G

H

I

J

K

L

M

N

O

P

# VDC OFF SWITCH

< REMOVAL AND INSTALLATION >

[VDC/TCS/ABS]

## VDC OFF SWITCH

Exploded View

INFOID:000000011401012

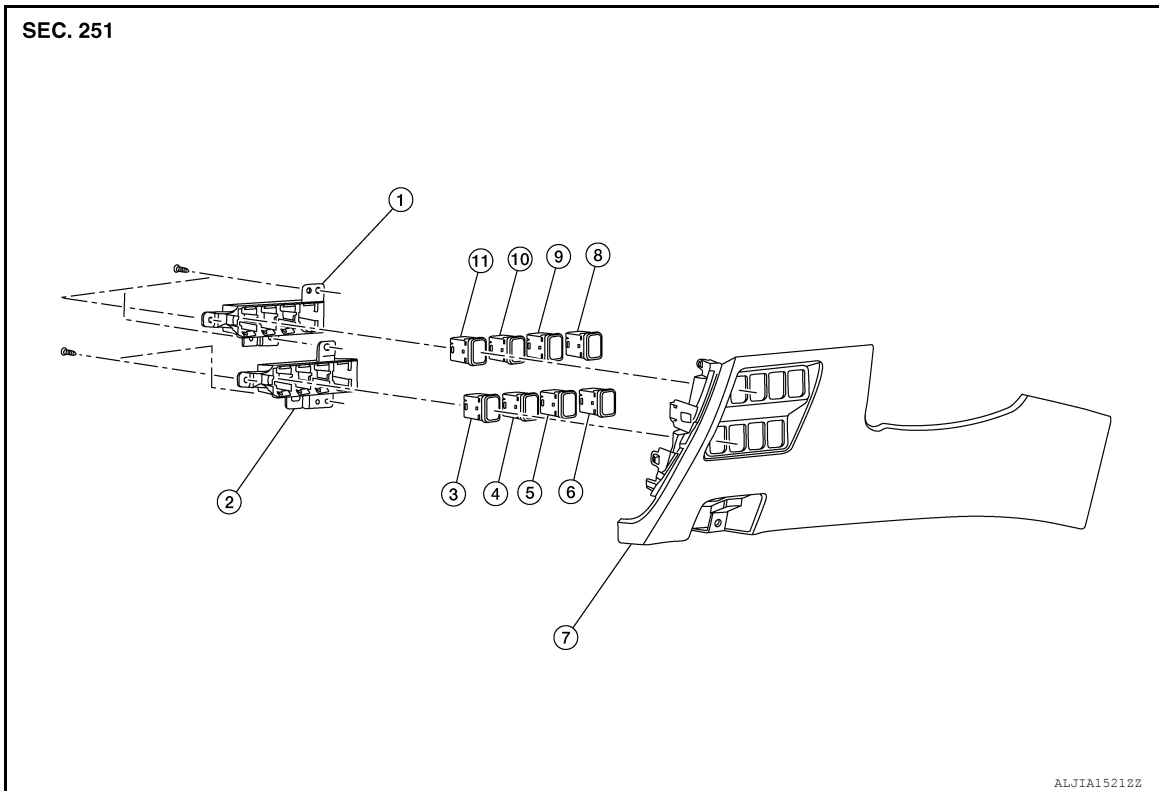

- |                              |                                    |                                |
|------------------------------|------------------------------------|--------------------------------|
| 1. Upper switch carrier      | 2. Lower switch carrier            | 3. Mask                        |
| 4. Warning system switch     | 5. AWD lock switch                 | 6. Hill descent control switch |
| 7. Instrument lower panel LH | 8. Automatic back door main switch | 9. Automatic back door switch  |
| 10. Sport mode switch        | 11. VDC OFF switch                 |                                |

## Removal and Installation

INFOID:000000011280678

### REMOVAL

1. Remove the instrument lower panel LH. Refer to [IP-23. "Removal and Installation"](#).
2. Remove the screws and upper switch carrier from the instrument lower panel LH.
3. Release pawls using suitable tool and remove the VDC OFF switch from the upper switch carrier.

○: Pawl

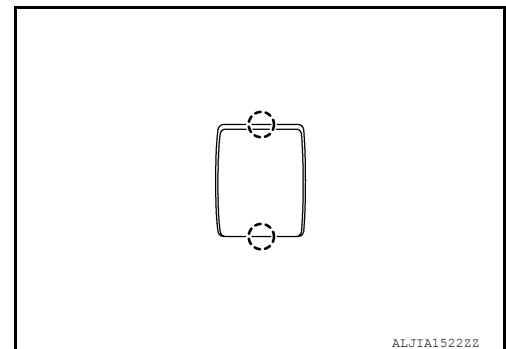

### INSTALLATION

Installation is in the reverse order of removal.



# STEERING ANGLE SENSOR

< REMOVAL AND INSTALLATION >

[VDC/TCS/ABS]

## STEERING ANGLE SENSOR

### Exploded View

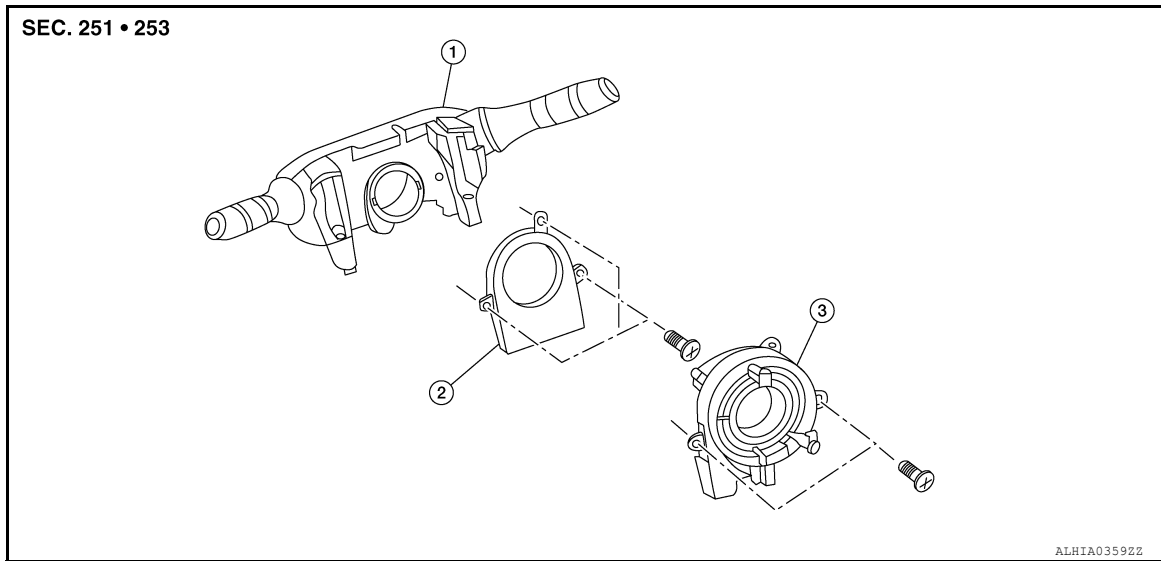

1. Combination switch

2. Steering angle sensor

3. Spiral cable

### Removal and Installation

INFOID:000000011280680

#### Removal and Installation

1. Remove the spiral cable. Refer to [SR-15, "Removal and Installation"](#).
2. Remove screws (A) and then remove steering angle sensor (1).

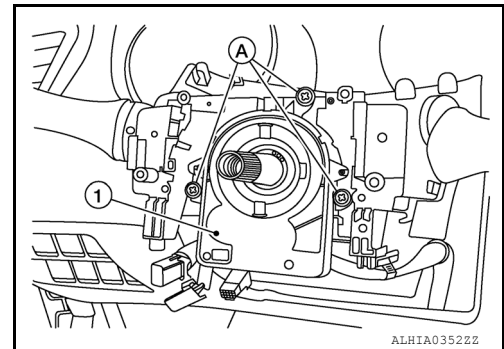

### INSTALLATION

Installation is in the reverse order of removal.

# HILL DESCENT CONTROL SWITCH

< REMOVAL AND INSTALLATION >

[VDC/TCS/ABS]

## HILL DESCENT CONTROL SWITCH

Exploded View

INFOID:000000011395887

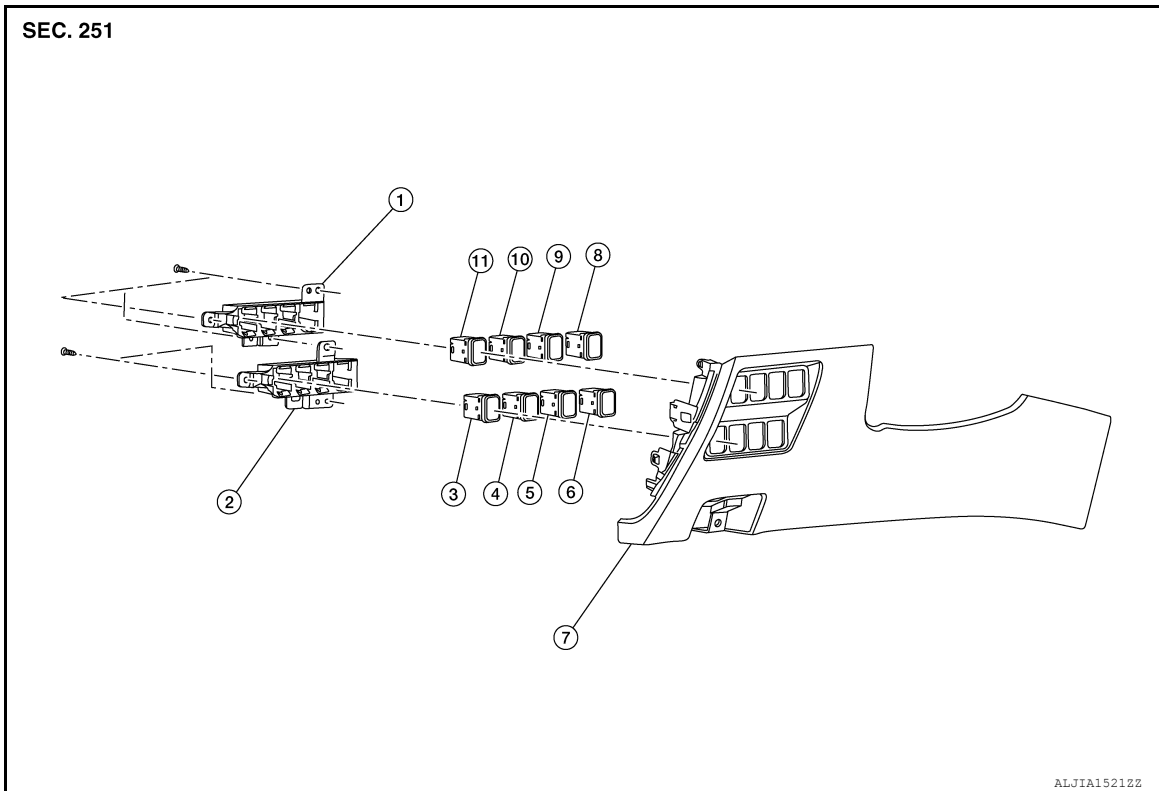

- |                              |                                    |                                |
|------------------------------|------------------------------------|--------------------------------|
| 1. Upper switch carrier      | 2. Lower switch carrier            | 3. Mask                        |
| 4. Warning system switch     | 5. AWD lock switch                 | 6. Hill descent control switch |
| 7. Instrument lower panel LH | 8. Automatic back door main switch | 9. Automatic back door switch  |
| 10. Sport mode switch        | 11. VDC OFF switch                 |                                |

## Removal and Installation

INFOID:000000011395888

### REMOVAL

1. Remove instrument lower panel LH. Refer to [IP-23, "Removal and Installation"](#).
2. Disconnect the harness connectors from the switches.
3. Remove the screws from the upper switch carrier and lower switch carrier.
4. Remove the upper switch carrier and lower switch carrier from the instrument lower panel LH.
5. Release pawls using suitable tool and remove the hill descent control switch from the lower switch carrier.

○: Pawl

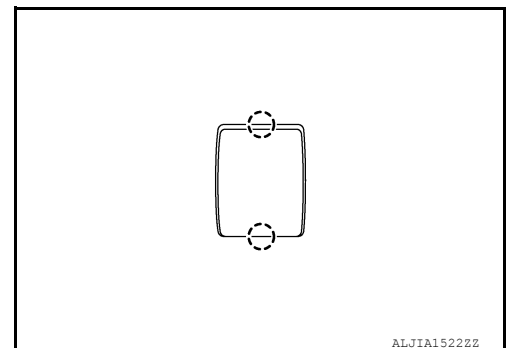

### INSTALLATION

Install in the reverse order of removal.