

A
EM
C
D
E
F
G
H
I
J
K
L
M
N
O
P

SECTION **EM**

ENGINE MECHANICAL

CONTENTS

PRECAUTION	3	SPARK PLUG	19
PRECAUTIONS	3	Exploded View	19
Precaution for Supplemental Restraint System (SRS) "AIR BAG" and "SEAT BELT PRE-TENSIONER"	3	Removal and Installation	19
Precaution for Draining Coolant and Engine Oil	3	CAMSHAFT VALVE CLEARANCE	21
Precaution for Procedure without Cowl Top Cover.....	3	Camshaft valve clearance	21
Parts Requiring Angle Tightening	3	COMPRESSION PRESSURE	24
Precautions For Engine Service	4	Compression pressure	24
Special Cautions to Ensure the Safe Disposal of Sodium-filled Exhaust Valves	4	REMOVAL AND INSTALLATION	26
Precaution for Liquid Gasket	6	AIR CLEANER AND AIR DUCT	26
SYMPTOM DIAGNOSIS	7	Exploded View	26
NOISE, VIBRATION, AND HARSHNESS (NVH) TROUBLESHOOTING	7	Removal and Installation	26
NVH Troubleshooting - Engine Noise	7	Inspection	28
Use the Chart Below to Help You Find the Cause of the Symptom	8	INTAKE MANIFOLD	29
PREPARATION	10	Exploded View	29
PREPARATION	10	Removal and Installation	29
Special Service Tools	10	EXHAUST MANIFOLD AND THREE WAY CATALYST	32
Commercial Service Tool	11	Exploded View	32
PERIODIC MAINTENANCE	15	Removal and Installation	32
DRIVE BELTS	15	OIL PAN AND OIL STRAINER	36
Exploded View	15	Exploded View	36
Checking	15	Removal and Installation	36
Tension Adjustment	15	IGNITION COIL	41
Removal and Installation	15	Exploded View	41
Removal and Installation of Drive Belt Auto-tensioner	16	Removal and Installation	41
AIR CLEANER FILTER	18	ROCKER COVER	42
Exploded View	18	Exploded View	42
Removal and Installation	18	Removal and Installation	42
		FUEL INJECTOR AND FUEL TUBE	45
		Exploded View	45
		Removal and Installation	45
		TIMING CHAIN	49

Exploded View	49	ENGINE ASSEMBLY	86
Removal and Installation	50	Exploded View	86
CYLINDER HEAD	59	Removal and Installation (FWD)	86
Exploded View	59	Removal and Installation (AWD)	90
Removal and Installation	59	Inspection	94
Disassembly and Assembly	61	UNIT DISASSEMBLY AND ASSEMBLY ...	96
Inspection After Disassembly	66	ENGINE STAND SETTING	96
CAMSHAFT	69	Setting	96
Exploded View	69	CYLINDER BLOCK	97
Removal and Installation	69	Exploded View	97
Inspection After Installation	77	Disassembly and Assembly	98
VALVE TIMING CONTROL	79	Inspection	105
Exploded View	79	HOW TO SELECT PISTON AND BEARING ..	114
Intake Valve Timing Intermediate Lock Control Solenoid Valve, Intake Valve Timing Control Solenoid Valve, and Exhaust Valve Timing Control Solenoid Valve	79	How to Select Piston and Bearing	114
Valve Timing Control Cover	80	SERVICE DATA AND SPECIFICATIONS (SDS)	120
OIL SEAL	82	SERVICE DATA AND SPECIFICATIONS (SDS)	120
VALVE OIL SEAL	82	General Specification	120
VALVE OIL SEAL : Removal and Installation	82	Drive belt	120
FRONT OIL SEAL	83	Spark Plug	120
FRONT OIL SEAL : Removal and Installation	83	Exhaust Manifold	121
REAR OIL SEAL	84	Camshaft	121
REAR OIL SEAL : Removal and Installation	84	Cylinder Head	122
UNIT REMOVAL AND INSTALLATION	86	Cylinder Block	125
		Main Bearing	128
		Connecting Rod Bearing	130

PRECAUTIONS

< PRECAUTION >

PRECAUTION

PRECAUTIONS

Precaution for Supplemental Restraint System (SRS) "AIR BAG" and "SEAT BELT PRE-TENSIONER"

INFOID:000000011279924

The Supplemental Restraint System such as "AIR BAG" and "SEAT BELT PRE-TENSIONER", used along with a front seat belt, helps to reduce the risk or severity of injury to the driver and front passenger for certain types of collision. Information necessary to service the system safely is included in the SR and SB section of this Service Manual.

WARNING:

- To avoid rendering the SRS inoperative, which could increase the risk of personal injury or death in the event of a collision which would result in air bag inflation, all maintenance must be performed by an authorized NISSAN/INFINITI dealer.
- Improper maintenance, including incorrect removal and installation of the SRS, can lead to personal injury caused by unintentional activation of the system. For removal of Spiral Cable and Air Bag Module, see the SR section.
- Do not use electrical test equipment on any circuit related to the SRS unless instructed to in this Service Manual. SRS wiring harnesses can be identified by yellow and/or orange harnesses or harness connectors.

PRECAUTIONS WHEN USING POWER TOOLS (AIR OR ELECTRIC) AND HAMMERS

WARNING:

- When working near the Airbag Diagnosis Sensor Unit or other Airbag System sensors with the Ignition ON or engine running, DO NOT use air or electric power tools or strike near the sensor(s) with a hammer. Heavy vibration could activate the sensor(s) and deploy the air bag(s), possibly causing serious injury.
- When using air or electric power tools or hammers, always switch the Ignition OFF, disconnect the battery and wait at least three minutes before performing any service.

Precaution for Draining Coolant and Engine Oil

INFOID:000000011340778

Drain engine coolant and engine oil after the engine has cooled completely.

Precaution for Procedure without Cowl Top Cover

INFOID:000000011279925

When performing the procedure after removing cowl top cover, cover the lower end of windshield with urethane, etc to prevent damage to windshield.

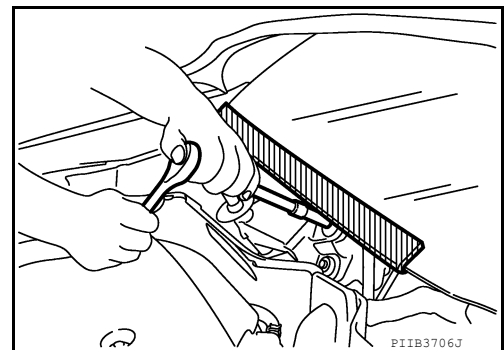

Parts Requiring Angle Tightening

INFOID:000000011279926

- Use the Tool for the final tightening of the following engine parts:

Tool number : KV10112100 (BT-8653-A)

- Camshaft sprocket (INT) bolt
- Cylinder head bolts
- Main bearing cap bolts
- Connecting rod cap bolts
- Crankshaft pulley bolt (The angle wrench is not required as bolt flange is provided with notches for angle tightening)

PRECAUTIONS

< PRECAUTION >

- Do not use a torque value for final tightening.
- Ensure thread and seat surfaces are clean and coated with engine oil.

Precautions For Engine Service

INFOID:000000011279927

DISCONNECTING FUEL PIPING

- Before starting work, check no fire or spark producing items are in the work area.
- Release fuel pressure before disconnecting and disassembly.
- After disconnecting pipes, plug openings to stop fuel leaks.

DRAINING ENGINE COOLANT

Drain engine coolant and engine oil when the engine is cooled.

INSPECTION, REPAIR AND REPLACEMENT

Before repairing or replacing, thoroughly inspect parts. Inspect new replacement parts in the same way, and replace if necessary.

REMOVAL AND DISASSEMBLY

- When instructed to use SST, use specified tools. Always be careful to work safely, avoid forceful or un instructed operations.
- Exercise maximum care to avoid damage to mating or sliding surfaces.
- Dowel pins are used for several parts alignment. When replacing and reassembling parts with dowel pins, check that dowel pins are installed in the original position.
- Cover openings of engine system with a tape or equivalent, if necessary, to seal out foreign materials.
- Mark and arrange disassembly parts in an organized way for easy troubleshooting and reassembly.
- When loosening nuts and bolts, as a basic rule, start with the one furthest outside, then the one diagonally opposite, and so on. If the order of loosening is specified, do exactly as specified. Power tools may be used in the step.

ASSEMBLY AND INSTALLATION

- Use torque wrench to tighten bolts or nuts to specification.
- When tightening nuts and bolts, as a basic rule, equally tighten in several different steps starting with the ones in center, then ones on inside and outside diagonally in this order. If the order of tightening is specified, do exactly as specified.
- Replace with new gasket, packing, oil seal or O-ring.
- Thoroughly wash, clean, and air-blow each part. Carefully check engine oil or engine coolant passages for any restriction and blockage.
- Avoid damaging sliding or mating surfaces. Completely remove foreign materials such as cloth lint or dust. Before assembly, oil sliding surfaces well.
- Release air within route when refilling after draining engine coolant.
- After repairing, start the engine and increase engine speed to check engine coolant, fuel, engine oil, and exhaust gases for leaks.

Special Cautions to Ensure the Safe Disposal of Sodium-filled Exhaust Valves

INFOID:000000011279928

Handling and disposal of sodium-filled exhaust valves requires special care and consideration. Under conditions such as breakage with subsequent contact with water, metal sodium which lines the inner portion of exhaust valve will react violently, forming sodium hydroxide and hydrogen which may result in an explosion. Sodium-filled exhaust valve is identified on the top of its stem as shown in illustration.

(A) : Identification mark of sodium-filled exhaust valve

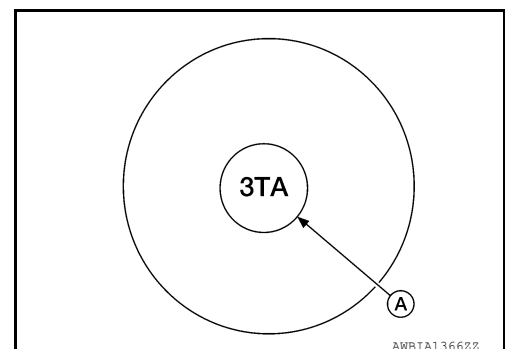

DEALER DISPOSAL INSTRUCTIONS

PRECAUTIONS

< PRECAUTION >

CAUTION:

- Use approved shatter-resistant eye protection when performing this procedure.
- Perform this and all subsequent disposal work procedures in an open room, away from flammable liquids. Keep a fire extinguisher, rated at least 10 ABC, in close proximity to the work area.
- Be sure to wear rubber gloves when performing the following operations.
- Make sure the resultant (high alkalinity) waste water does not contact your skin. If the waste water does contact you, wash the contacted area immediately with large quantities of water.
- Dealers should check their respective state and local regulations concerning any chemical treatment or waste water discharge permits which may be required to dispose of the resultant (high alkalinity) waste water.

1. Clamp valve stem in a vice.
2. The valve has a specially-hardened surface. To cut through it, first remove a half-round section, approximately 30 mm (1.18 in) long using air-powered grinder until black color is removed and silver color appears.

- (A) : Black color
- (B) : Silver color
- (c) : 47 mm (1.85 in)
- (d) : 17 mm (0.67 in)

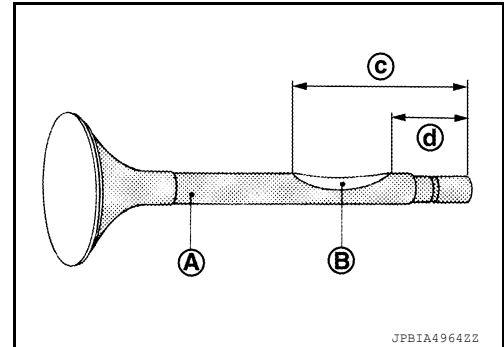

3. Use hacksaw to cut through approximately half the diameter of valve stem. Make the serration at a point 40 mm (1.57 in) from the end of valve stem.

- (a) : 40 mm (1.57 in)

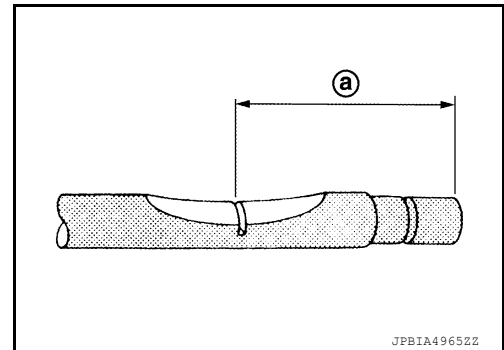

4. Cover the serrated end of the valve with a large shop towel (A). Strike the valve face end with a hammer, separating it into two pieces.
5. Fill a bucket, such as a 20 ℓ (5-1/4 US gal, 4-3/8 Imp gal) oil can, with at least 10 ℓ (2-5/8 US gal, 2-1/4 Imp gal) of water. Carefully place the already cut (serrated) valves into the water one-at-a-time using a set of large tweezers and quickly move away at least 2.7 m (9 ft).

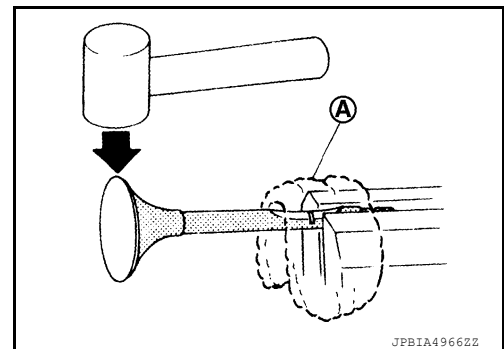

6. The valves should be placed in a standing position as shown in the illustration to allow complete reaction. After the bubbling action has subsided, additional valves can be placed into the bucket allowing each subsequent chemical reaction to subside. However, no more than 8 valves should be placed in the same 10 ℓ (2-5/8 US gal, 2-1/4 Imp gal) amount of water. The complete chemical reaction may take as long as 4 to 5 hours. Remove the valves using a set of large tweezers after the chemical reaction has stopped. Afterwards, valves can be disposed as ordinary scrap.

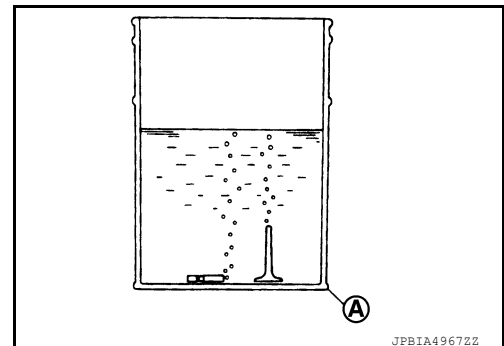

- A : Bucket [Such as 20 ℓ (5-1/4 US gal, 4-3/8 Imp gal) oil can]

PRECAUTIONS

< PRECAUTION >

Precaution for Liquid Gasket

INFOID:000000011340781

REMOVAL OF LIQUID GASKET SEALING

- After removing the bolts and nuts, separate the mating surface and remove the liquid gasket using Tool (A).

Tool Number : KV10111100 (J-37228)

CAUTION:

Be careful not to damage the mating surfaces.

- In areas where the cutter is difficult to use, use a plastic hammer to lightly tap (1) the cutter where the liquid gasket is applied. Use a plastic hammer to slide (2) the cutter by tapping on the side.

CAUTION:

Do not damage the mating surfaces.

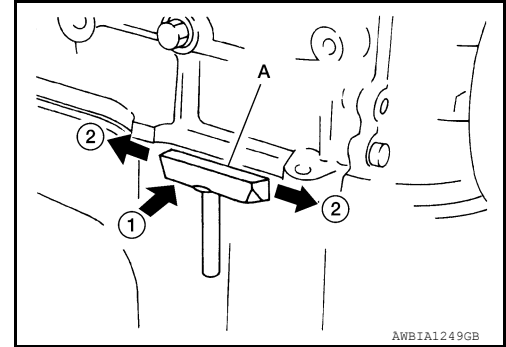

LIQUID GASKET APPLICATION PROCEDURE

1. Using suitable tool (A), remove old liquid gasket adhering to the liquid gasket application surface and the mating surface.
 - Remove liquid gasket completely from the groove of the liquid gasket application surface, mounting bolts, and bolt holes.
2. Thoroughly clean the mating surfaces and remove adhering moisture, grease and foreign materials.

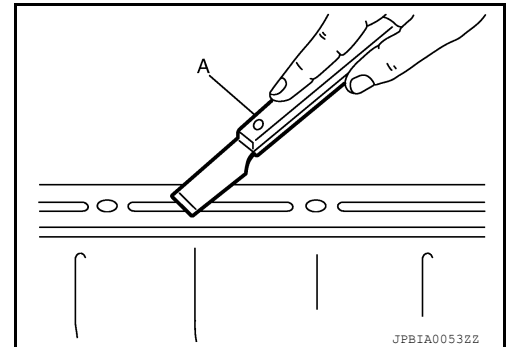

3. Attach liquid gasket tube to the suitable tool.
Use Genuine Silicone RTV Sealant, or equivalent. Refer to [GI-22, "Recommended Chemical Products and Sealants"](#).
4. Apply liquid gasket without gaps to the specified location according to the specified dimensions.
 - If there is a groove for liquid gasket application, apply liquid gasket to the groove.

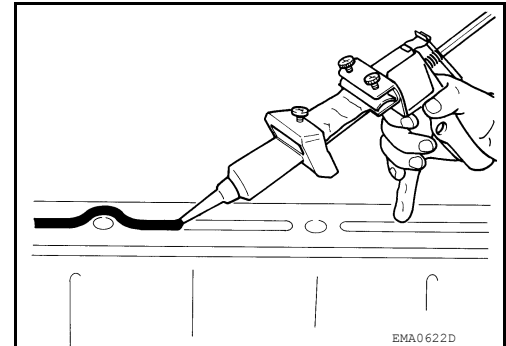

- As for bolt holes (B), normally apply liquid gasket inside the holes. Occasionally, it should be applied outside the holes. Check to read the text of this manual.

(A) : Groove

⇐ : Inside

- Within five minutes of liquid gasket application, install the mating component.
- If liquid gasket protrudes, wipe it off immediately.
- Do not retighten mounting bolts or nuts after the installation.
- After 30 minutes or more have passed from the installation, fill engine oil and engine coolant. Refer to [LU-8, "Refilling"](#) and [CO-9, "Refilling"](#).

CAUTION:

If there are more specific instructions in the procedures contained in this manual concerning liquid gasket application, observe them.

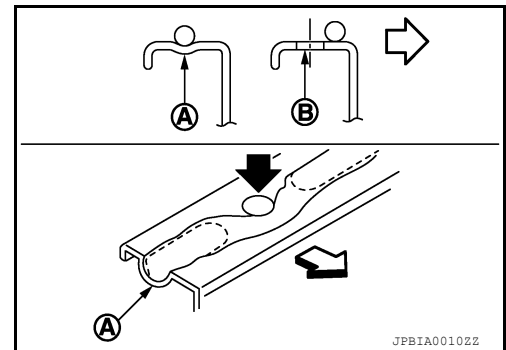

NOISE, VIBRATION, AND HARSHNESS (NVH) TROUBLESHOOTING

< SYMPTOM DIAGNOSIS >

- | | | |
|-----------------------|---|--------------------------------|
| 1. Valve mechanism | 2. Intake and exhaust valve | 3. Water pump |
| 4. Timing chain | 5. Drive belt | 6. Rotation mechanism |
| A. Tappet noise | B. Camshaft bearing noise | C. Water pump noise |
| D. VTC noise | E. Timing chain and chain tensioner noise | F. Drive belt noise (slipping) |
| G. Main bearing noise | H. Connecting rod bearing noise | J. Piston pin noise |
| K. Piston slap noise | | |

Use the Chart Below to Help You Find the Cause of the Symptom

INFOID:000000011279931

1. Locate the area where noise occurs.
2. Confirm the type of noise.
3. Specify the operating condition of engine.
4. Check specified noise source.

If necessary, repair or replace these parts.

Location of noise	Type of noise	Operating condition of engine						Source of noise	Check item	Reference page
		Before warm-up	After warm-up	When starting	When idling	When racing	While driving			
Top of engine Rocker cover Cylinder head	Ticking or clicking	C	A	—	A	B	—	Tappet noise	Valve clearance	EM-121
	Rattle	C	A	—	A	B	C	Camshaft bearing noise	Camshaft journal clearance Camshaft runout	EM-121 EM-121
Crankshaft pulley Cylinder block (Side of engine) Oil pan	Slap or knock	—	A	—	B	B	—	Piston pin noise	Piston and piston pin clearance Connecting rod bushing clearance	EM-130 EM-130
	Slap or rap	A	—	—	B	B	A	Piston slap noise	Piston-to-bore clearance Piston ring side clearance Piston ring end gap Connecting rod bend and torsion	EM-130 EM-130 EM-130 EM-130
	Knock	A	B	C	B	B	B	Connecting rod bearing noise	Connecting rod bushing clearance (Small end) Connecting rod bearing clearance (Big end)	EM-130 EM-130
	Knock	A	B	—	A	B	C	Main bearing noise	Main bearing oil clearance Crankshaft runout	EM-128 EM-125
Front of engine Timing chain cover	Tapping or ticking	A	A	—	B	B	B	Timing chain and chain tensioner noise	Timing chain cracks and wear Timing chain tensioner operation	EM-50

NOISE, VIBRATION, AND HARSHNESS (NVH) TROUBLESHOOTING

< SYMPTOM DIAGNOSIS >

Location of noise	Type of noise	Operating condition of engine						Source of noise	Check item	Reference page
		Before warm-up	After warm-up	When starting	When idling	When racing	While driving			
Front of engine	Squeaking or fizzing	A	B	—	B	—	B	Drive belts (Sticking or slipping)	Drive belts deflection	EM-15
	Creaking	A	B	A	B	A	B	Drive belts (Slipping)	Idler pulley bearing operation	
	Squall Creak	A	B	—	B	A	B	Water pump noise	Water pump operation	CO-19
	Rattle	—	—	A	—	—	—	VTC	VTC sprockets	EM-79

A: Closely related B: Related C: Sometimes related —: Not related

A

EM

C

D

E

F

G

H

I

J

K

L

M

N

O

P

PREPARATION

< PREPARATION >

PREPARATION

PREPARATION

Special Service Tools

INFOID:000000011340782

The actual shape of the tools may differ from those illustrated here.

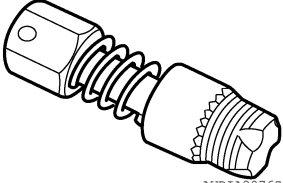
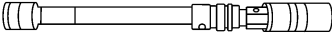
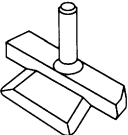
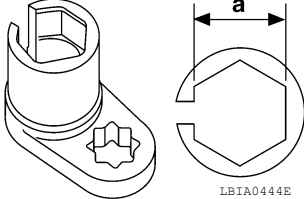
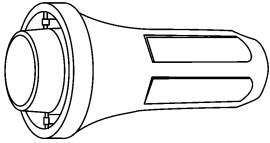
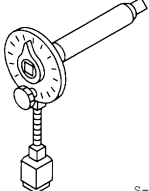
Tool number (TechMate No.) Tool name	Description
(J-43897-18) Oxygen sensor thread cleaner  <p style="text-align: center;">AWBIA2076ZZ</p>	Reconditioning the exhaust system threads before installing a new oxygen sensor (Use with anti-seize lubricant shown below.) J-43897-18 (18 mm dia.) for zirconia oxygen sensor
— (J-48891) Spark plug socket  <p style="text-align: center;">AWBIA1785ZZ</p>	Removing and installing spark plug
KV1011100 (J-37228) Seal cutter  <p style="text-align: center;">S-NT046</p>	Removing oil pan and timing chain case
KV991J0050 (J-44626) Air fuel sensor Socket  <p style="text-align: center;">LBIA0444E</p>	Loosening or tightening air fuel ratio A/F sensor a: 22 mm (0.87 in)
— (J-37067) Seal installer  <p style="text-align: center;">AWBIA2081ZZ</p>	Installing rear main seal
KV10112100 (BT-8653-A) Torque angle meter  <p style="text-align: center;">S-NT014</p>	Tightening bolts for bearing cap, cylinder head, etc.

PREPARATION

< PREPARATION >

Commercial Service Tool

INFOID:000000011340783

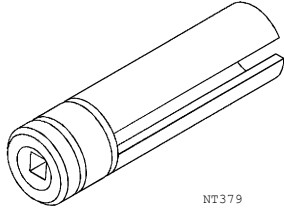
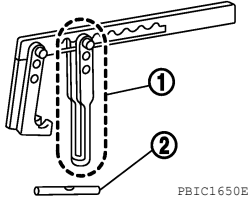
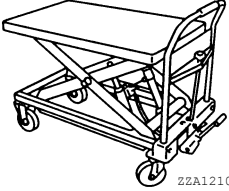
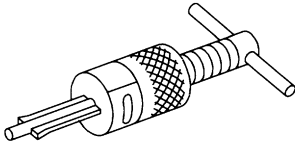
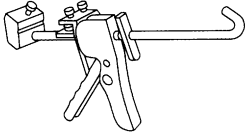
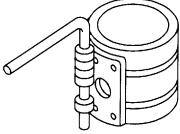
Tool number (TechMate No.) Tool name	Description	EM
KV10117100 (J-36471-A) Heated oxygen sensor wrench	 Loosening or tightening heated oxygen sensor For 22 mm (0.87 in) hexagon nut	A C
KV10116200 (J-26336-A) Valve spring compressor 1. KV10115900 (J-26336-20) Attachment 2. KV10109220 (—) Adapter	 Disassembling valve mechanism Part (1) is a component of KV10116200 (J-26336-A), but part (2) is not.	D E F
Manual lift table caddy	 Removing and installing engine	G H I
ST16610001 (J-23907) Pilot converter puller	 Removing crankshaft pilot converter	J K
Tube presser	 Pressing the tube of liquid gasket	L M
Piston ring compressor	 Installing piston assembly into cylinder bore	N O P

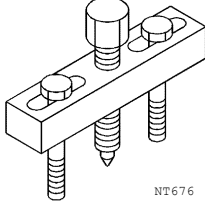
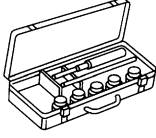
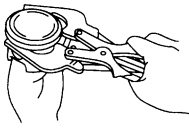
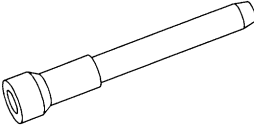
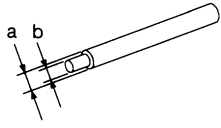
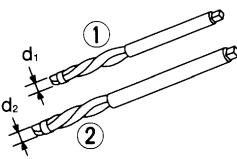

PREPARATION

< PREPARATION >

Tool number (TechMate No.) Tool name	Description
Pulley holder  ZZA1010D	Crankshaft pulley removing and installing
Pulley puller  NT676	Removing crankshaft pulley
Valve seat cutter set  S-NT048	Finishing valve seat dimensions
Piston ring expander  S-NT030	Removing and installing piston ring
— (J-39386) Valve oil seal drift  NT024	Installing valve oil seal
Valve guide drift  S-NT015	Removing and installing valve guide Intake & Exhaust: a: 9.5 mm (0.374 in) dia. b: 5.5 mm (0.217 in) dia.
Valve guide reamer  S-NT016	1: Reaming valve guide inner hole 2: Reaming hole for oversize valve guide Intake & Exhaust: d1: 6.0 mm (0.236 in) dia. d2: 10.2 mm (0.402 in) dia.

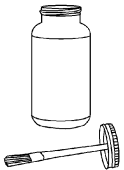
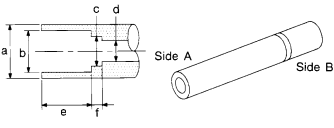

PREPARATION

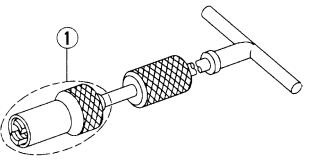
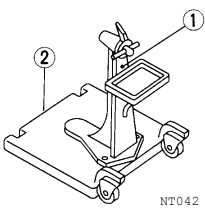
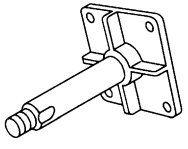
< PREPARATION >

Tool number (TechMate No.) Tool name	Description	
Anti-seize lubricant (Permatex 133AR or equivalent meeting MIL specification MIL-A-907) <div style="text-align: center;">  <p>AEM489</p> </div>	Lubricating oxygen sensor thread cleaning tool when reconditioning exhaust system threads	A EM C
KV10115600 (J-38958) Valve oil seal drift <div style="text-align: center;">  <p>S-NT603</p> </div>	Installing valve oil seal Use side A. a: 20 (0.79) dia. d: 8 (0.31) dia. b: 13 (0.51) dia. e: 10.7 (0.421) dia. c: 10.3 (0.406) dia. f: 5 (0.20) dia. Unit: mm (in)	D E F
Power tool <div style="text-align: center;">  <p>PIIB1407E</p> </div>	Loosening nuts, screws, and bolts	G H
KV10107902 (J-38959) Valve oil seal puller with adapter (1) <div style="text-align: center;">  <p>S-NT605</p> </div>	Removing valve oil seal	I J
ST0501S000 Engine stand assembly (—) 1. ST05011000 (—) Engine stand 2. ST05012000 (—) Base <div style="text-align: center;">  <p>NT042</p> </div>	Disassembling and assembling	K L M
KV10106500 (—) Engine stand shaft <div style="text-align: center;">  <p>NT028</p> </div>	Engine supporting	N O P

PREPARATION

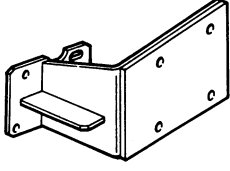
< PREPARATION >

Tool number (TechMate No.) Tool name	Description
KV10115300 (—) Engine sub-attachment  ZZA1078D	Disassembling and assembling
(J-45816) E20 Socket  LBIA0285E	Removing and installing CVT drive plate bolts

DRIVE BELTS

< PERIODIC MAINTENANCE >

PERIODIC MAINTENANCE

DRIVE BELTS

Exploded View

INFOID:0000000011279934

A

EM

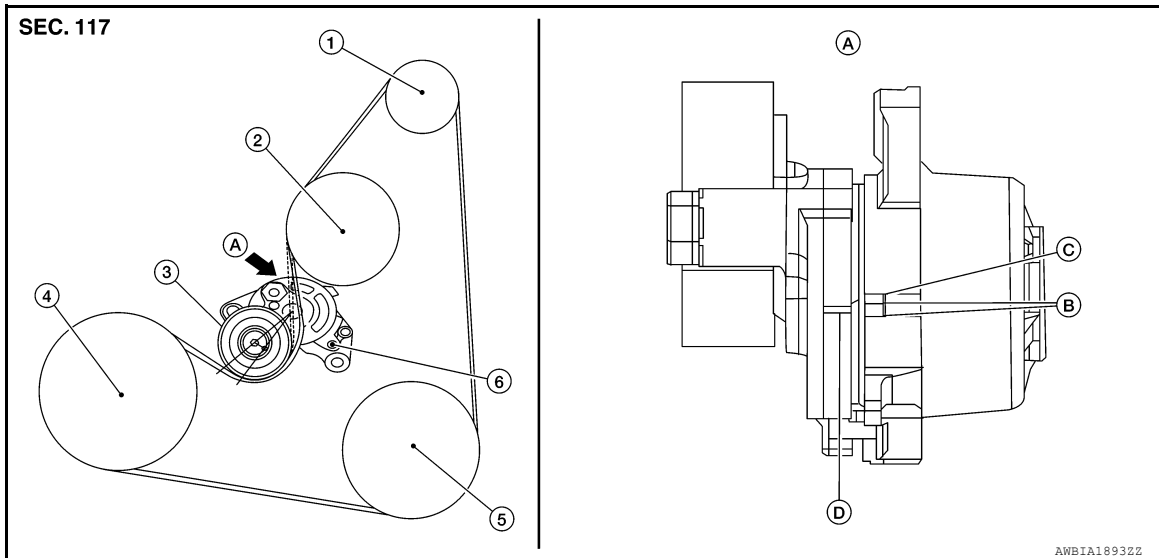

- | | | |
|----------------------|--------------------------|------------------------------|
| 1. Generator pulley | 2. Water pump pulley | 3. Drive belt auto-tensioner |
| 4. Crankshaft pulley | 5. A/C compressor pulley | 6. Drive belt retainer boss |
| A. View A | B. New drive belt range | C. Maximum belt length |
| D. Indicator (notch) | | |

Checking

INFOID:0000000011279935

WARNING:

Inspect the drive belt only when the engine is stopped.

1. Visually check entire drive belt for wear, damage or cracks.
2. Check that the drive belt auto-tensioner indicator is within the possible use range.

NOTE:

- When new drive belt is installed, the drive belt auto-tensioner indicator should be within the new drive belt range.
 - Check the drive belt auto-tensioner indicator when the engine is cold.
3. If the drive belt auto-tensioner indicator is out of the possible use range or belt is damaged, replace drive belt.

Tension Adjustment

INFOID:0000000011279936

Belt tension is not manually adjustable. It is automatically adjusted by the drive belt auto-tensioner.

Removal and Installation

INFOID:0000000011279937

REMOVAL

1. Remove wheel and tire (RH) using a power tool.
2. Remove engine under cover. Refer to [EXT-37, "ENGINE UNDER COVER : Removal and Installation"](#)
3. Remove fender protector side cover. Refer to [EXT-28, "FENDER PROTECTOR : Exploded View"](#).

C

D

E

F

G

H

I

J

K

L

M

N

O

P

DRIVE BELTS

< PERIODIC MAINTENANCE >

- Securely hold the hexagonal part (A) of drive belt auto-tensioner (1) using suitable tool, and move in the direction of arrow (loosening direction of tensioner).
- Insert a rod approximately 6 mm (0.24 in) in diameter through the rear of the drive belt auto-tensioner into retaining boss (B) to lock drive belt auto-tensioner pulley.

WARNING:

Avoid placing hand in a location where pinching may occur if the holding tool accidentally comes off.

NOTE:

Leave drive belt auto-tensioner pulley arm locked until drive belt is installed again.

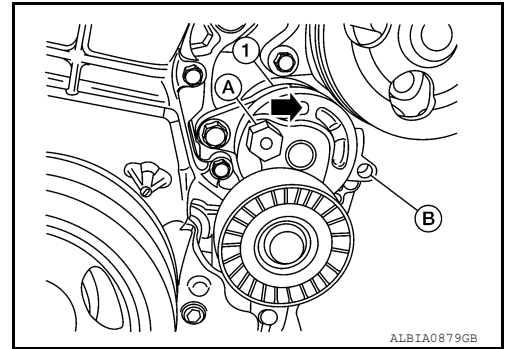

- Loosen drive belt from drive belt auto-tensioner and then remove it from the other pulleys.
- Installation of remaining components is in the reverse order of removal.

INSTALLATION

Installation is in the reverse order of removal.

- Install the drive belt onto all of the pulleys except for the drive belt auto-tensioner. Then install the drive belt onto drive belt auto-tensioner last.

CAUTION:

- Confirm belts are completely set on the pulleys.
- Check for engine oil and engine coolant. Be sure they are not adhered to the drive belt and each pulley groove.

- Release the drive belt auto-tensioner and apply tension to drive belt.

WARNING:

Avoid placing hand in a location where pinching may occur if the holding tool accidentally comes off.

- Turn crankshaft pulley clockwise several times to equalize tension between each pulley.
- Confirm the indicator is within the possible use range. Refer to [EM-15. "Checking"](#).
- Install wheel and tire (RH). Refer to [WT-64. "Adjustment"](#).

Removal and Installation of Drive Belt Auto-tensioner

INFOID:000000011279938

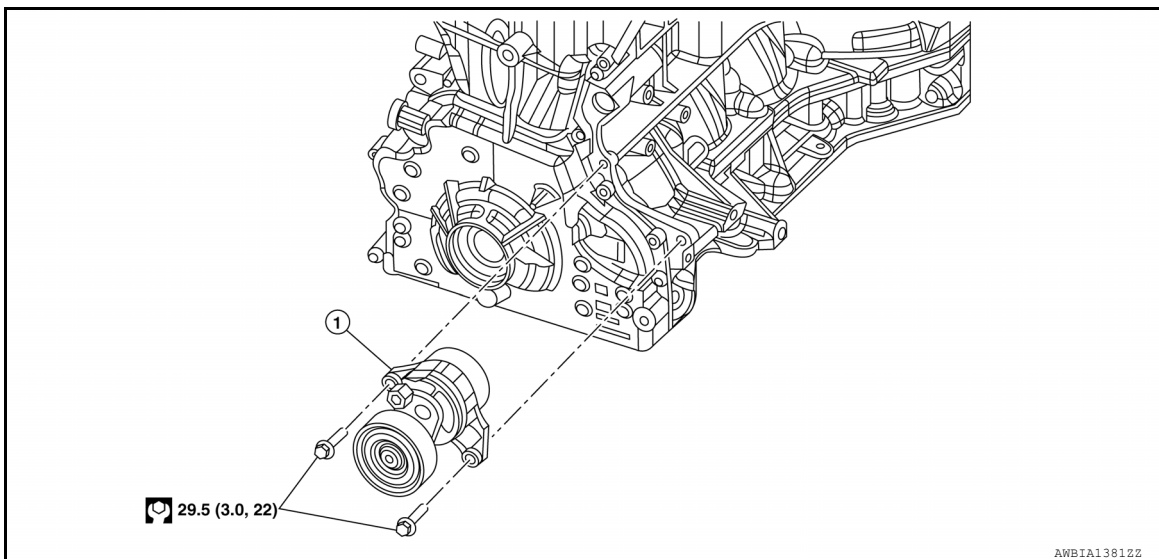

1. Drive belt auto-tensioner

REMOVAL

CAUTION:

The complete drive belt auto-tensioner must be replaced as a unit, including the pulley.

DRIVE BELTS

< PERIODIC MAINTENANCE >

1. Remove the drive belt. Refer to [EM-15. "Removal and Installation"](#).
2. Remove the drive belt auto-tensioner.

INSTALLATION

Installation is in the reverse order of removal.

CAUTION:

- Install the drive belt auto-tensioner carefully so not to damage the water pump pulley.
- If there is damage greater than peeled paint, replace the drive belt auto-tensioner.

A

EM

C

D

E

F

G

H

I

J

K

L

M

N

O

P

AIR CLEANER FILTER

< PERIODIC MAINTENANCE >

AIR CLEANER FILTER

Exploded View

INFOID:000000011279939

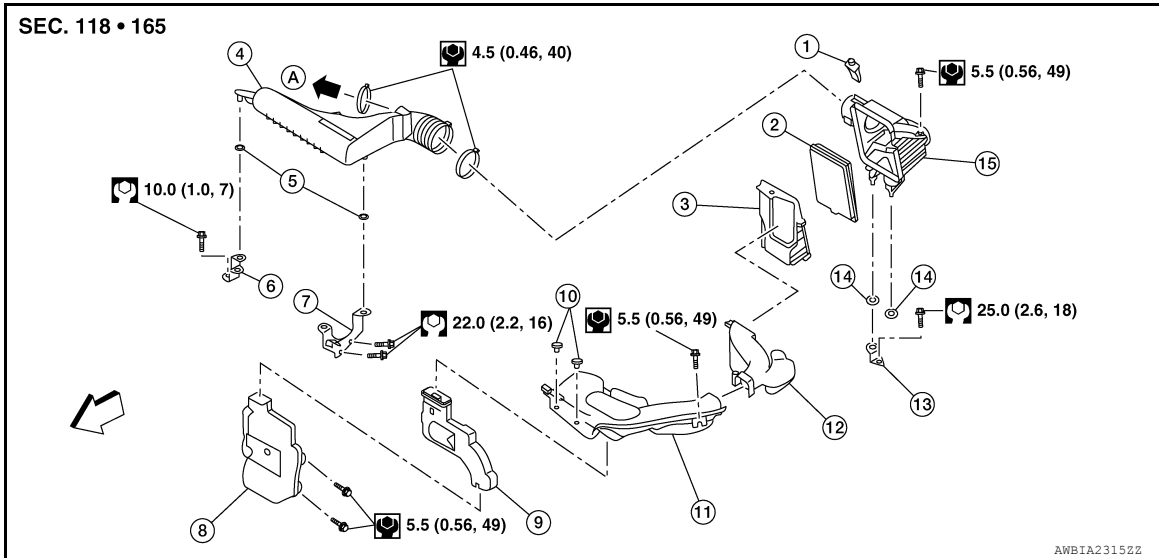

- | | | |
|--|------------------------------|------------------------------|
| 1. Mass air flow sensor | 2. Air cleaner filter | 3. Air cleaner case (lower) |
| 4. Air duct assembly (aft) | 5. Grommet | 6. Resonator bracket (front) |
| 7. Resonator bracket (rear) | 8. Resonator | 9. Air duct |
| 10. Mounting clip | 11. Air duct assembly (fore) | 12. Air duct assembly |
| 13. Air cleaner bracket | 14. Grommet | 15. Air cleaner case (upper) |
| A. To Electric throttle control actuator | ↔ Front | |

Removal and Installation

INFOID:000000011279940

CHANGING THE AIR CLEANER FILTER

1. Remove air duct assembly from air cleaner case (upper).
2. Open the air cleaner case.
3. Remove the air cleaner filter.
4. Install a new air cleaner filter.
5. Close the air cleaner case.
6. Secure the air cleaner case clips.

INSPECTION AFTER REMOVAL

Examine the air cleaner filter for stains, clogging, or damage.

- Remove dirt and foreign objects (such as dead leaves) on air cleaner filter surface and inside cleaner case.
- If clogging or damage is observed, replace the air cleaner filter.

CAUTION:

Do not clean the viscous paper type air cleaner filter by blowing as there is a risk of deterioration of its performance.

MAINTENANCE INTERVAL

Refer to [MA-7, "Introduction of Periodic Maintenance"](#).

SPARK PLUG

< PERIODIC MAINTENANCE >

SPARK PLUG

Exploded View

INFOID:000000011279941

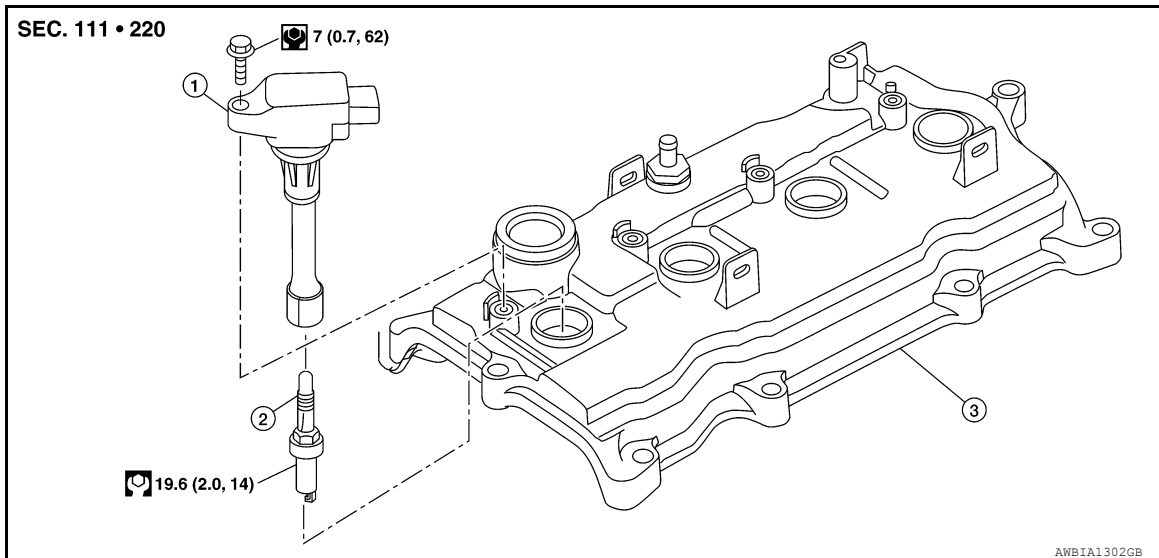

1. Ignition coil

2. Spark plug

3. Rocker cover

Removal and Installation

INFOID:000000011279942

REMOVAL

1. Remove air duct assembly.
2. Remove ignition coil. Refer to [EM-41, "Exploded View"](#).
3. Remove spark plug using Tool.

Tool number : — (J-48891)

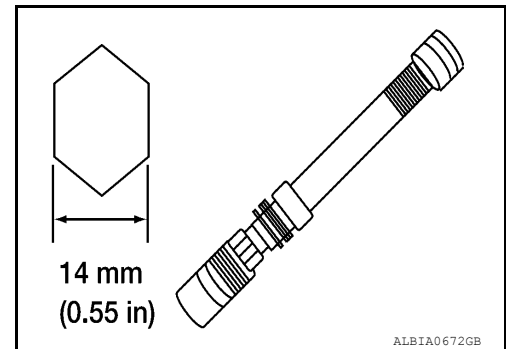

INSPECTION AFTER REMOVAL

Visually check the electrode for dirt and wear and the insulator for burning.

(A) : Iridium alloy

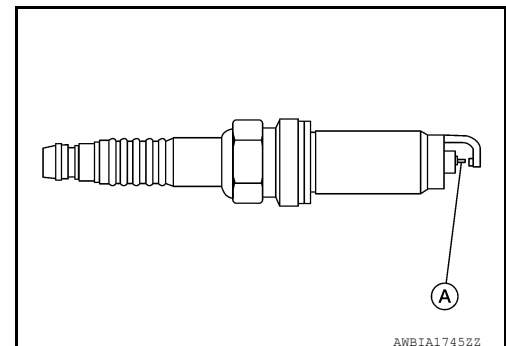

SPARK PLUG

< PERIODIC MAINTENANCE >

- Do not use a wire brush for cleaning the spark plugs. Replace as necessary.

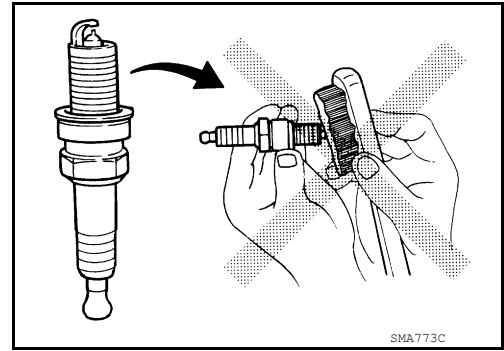

- If plug is covered with carbon, a spark plug cleaner may be used.

Cleaner air pressure : less than 588 kPa (6 kg/cm², 85 psi)

Cleaning time : less than 20 seconds

- Checking and adjusting plug gap is not required between change intervals. If the gap is out of specification, replace the spark plug.

CAUTION:

Do not drop or shock plug.

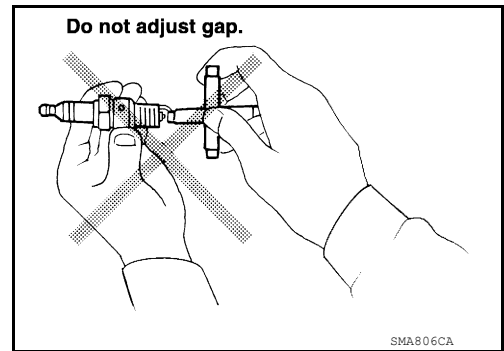

INSTALLATION

Installation is in the reverse order of removal.

Standard type*	DENSO
	FXE20HE11C
Gap (nominal)	1.1 mm (0.043 in)

*: Always check with the Parts Department for the latest parts information.

CAMSHAFT VALVE CLEARANCE

< PERIODIC MAINTENANCE >

CAMSHAFT VALVE CLEARANCE

Camshaft valve clearance

INFOID:0000000011279943

A

EM

- Perform this inspection as follows after removal, installation, or replacement of the camshaft or any valve parts, or if there are any unusual engine conditions due to changes in valve clearance over time (starting, idling, and/or noise).

1. Remove the fender protector side cover (RH). Refer to [EXT-28. "FENDER PROTECTOR : Exploded View"](#).

2. Remove the rocker cover. Refer to [EM-42. "Exploded View"](#).

3. Turn crankshaft pulley clockwise when viewed from front to align TDC identification mark (B) with timing indicator (A).

NOTE:

Do not confuse TDC mark (B) with paint marks (C).

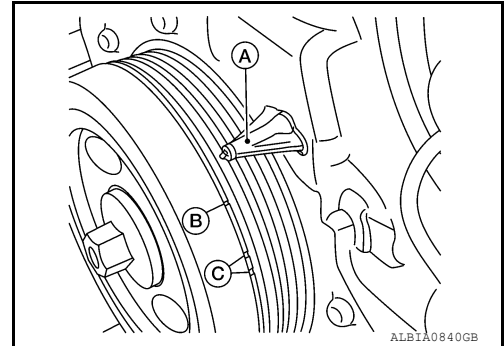

4. At this time, check that the both intake and exhaust cam lobes of No. 1 cylinder face outside.

- If they do not face outside, turn crankshaft pulley once more.

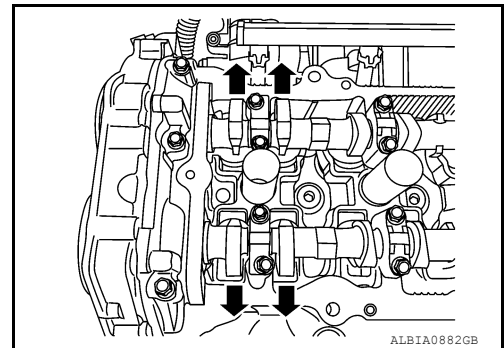

5. Measure valve clearances with a suitable tool at locations marked (X) in the table below.

- No.1 cylinder compression TDC.

Cylinder	No.1 (A)		No.2 (B)		No.3 (C)		No.4 (D)	
Valve	INT (E)	EXH (F)	INT (E)	EXH (F)	INT (E)	EXH (F)	INT (E)	EXH (F)
Measure	x	x	x			x		

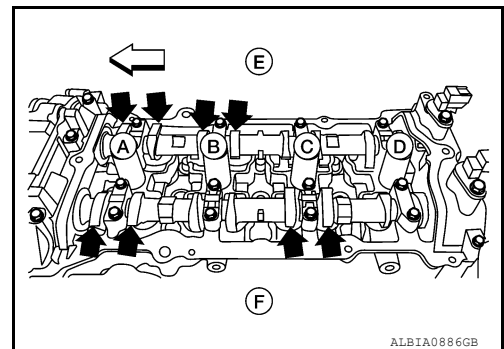

← : Engine front

C

D

E

F

G

H

I

J

K

L

M

N

O

P

CAMSHAFT VALVE CLEARANCE

< PERIODIC MAINTENANCE >

- Use a suitable tool to measure the clearance between valve lifter and camshaft.

Valve clearance: Refer to [EM-121, "Camshaft"](#).

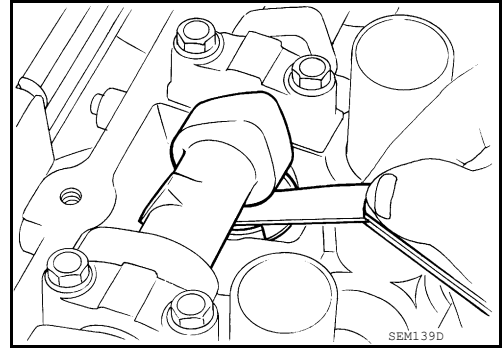

- Turn crankshaft one complete revolution (360°) and align mark on crankshaft pulley with pointer.
- Measure valve clearances with a suitable tool at locations marked (X) in the table below.
 - No.4 cylinder compression TDC.

Cylinder	No.1 (A)		No.2 (B)		No.3 (C)		No.4 (D)	
Valve	INT (E)	EXH (F)	INT (E)	EXH (F)	INT (E)	EXH (F)	INT (E)	EXH (F)
Measure				X	X		X	X

If out of specifications, make necessary adjustment.

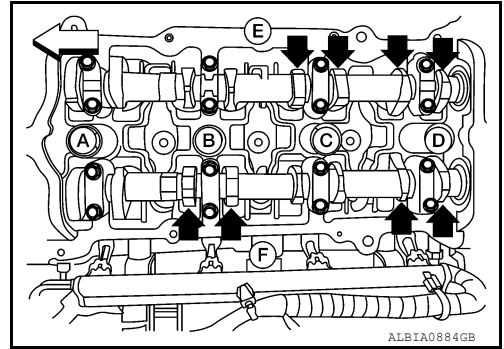

← : Engine front

ADJUSTMENT

NOTE:

- Perform adjustment by selecting the valve lifter with the correct head thickness.
- Remove camshaft. Refer to [EM-121, "Camshaft"](#).
 - Remove the valve lifters at the locations that are outside the standard.
 - Measure the center thickness of the removed valve lifters with a suitable tool (A).

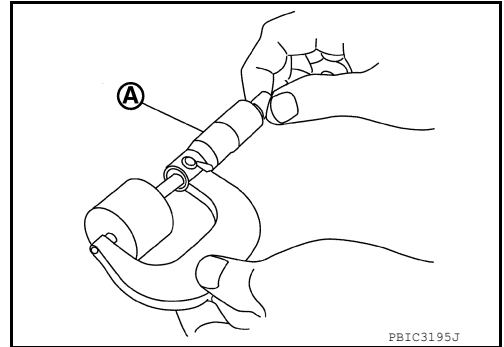

- Use the equation below to calculate valve lifter thickness for replacement.

- Valve lifter thickness calculation.

$$t = t1 + (C1 - C2)$$

t = Thickness of replacement valve lifter.
 t1 = Thickness of removed valve lifter.
 C1 = Measured valve clearance.
 C2 = Standard valve clearance.

CAMSHAFT VALVE CLEARANCE

< PERIODIC MAINTENANCE >

- Thickness of a new valve lifter (B) can be identified by stamp marks (A) on the reverse side (inside the cylinder). Stamp mark 324H indicates a thickness of 3.24 mm (0.1276 in)

Available thickness of valve lifter: 26 sizes with a range of 3.00 to 3.50 mm (0.1181 to 0.1378 in), in steps of 0.02 mm (0.0008 in), when assembled at the factory.

5. Install the selected valve lifter.
6. Install camshaft. Refer to [EM-69, "Removal and Installation"](#).
7. Install timing chain and related parts. Refer to [EM-49, "Exploded View"](#).
8. Manually rotate crankshaft pulley a few rotations.
9. Check that valve clearances for cold engine are within specifications by referring to the specified values.

Valve clearance Refer to [EM-121, "Camshaft"](#).

10. Install all removed parts in the reverse order of removal.
11. Warm up the engine, and check for unusual noise and vibration.

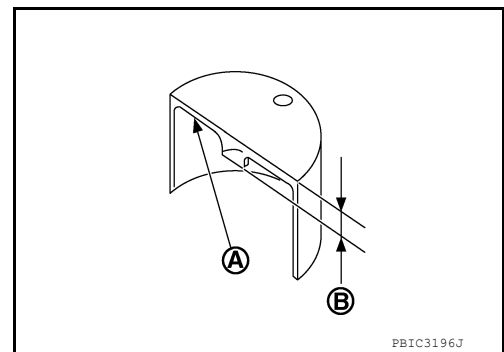

A

EM

C

D

E

F

G

H

I

J

K

L

M

N

O

P

COMPRESSION PRESSURE

< PERIODIC MAINTENANCE >

COMPRESSION PRESSURE

Compression pressure

INFOID:000000011279944

CHECKING COMPRESSION PRESSURE

1. Warm up the engine to full operating temperature.
2. Release the fuel pressure. Refer to [EC-147, "Work Procedure"](#).
3. Remove the ignition coil and spark plug from each cylinder. Refer to [EM-41, "Removal and Installation"](#) and [EM-19, "Removal and Installation"](#).
4. Connect engine tachometer (not required in use of CONSULT).
5. Disconnect the fuel injector harness connector to avoid any residual fuel injection during the measurement.
6. Install the compression tester with the adapter into the spark plug hole.

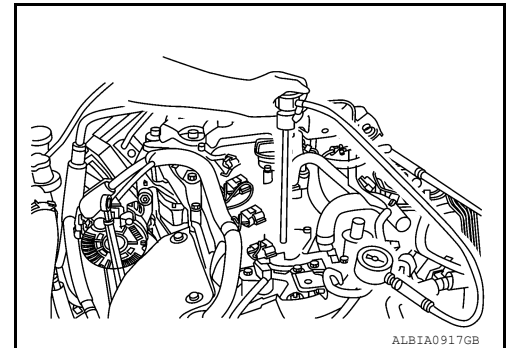

- Use compression tester whose end (a) (rubber portion) is smaller than 20 mm (0.79 in) in diameter. Otherwise, it may be caught by cylinder head during removal.

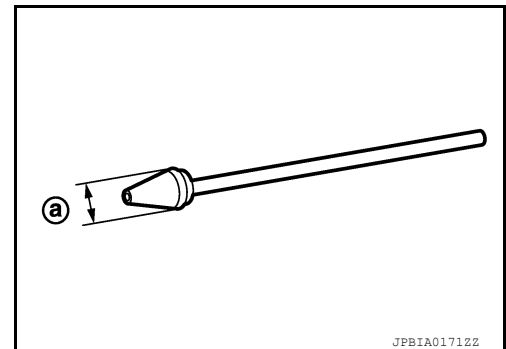

7. With the accelerator pedal fully depressed, turn the ignition switch to the "START" position to crank over the engine. When the gauge pointer stabilizes, read the compression pressure and engine rpm. Perform these steps to check each cylinder.

Unit: kPa (kg/cm², psi) / rpm

Standard	Minimum	Difference limit between cylinders
1410 (14.4, 204.5) / 250	1220 (12.4, 176.9) / 250	100 (1.0, 14) / 250

CAUTION:

Always use a fully charged battery to obtain specified engine cranking speed.

- If the engine speed is out of specified rpm range, check the battery. Check engine speed again with a fully charged battery.
- If compression pressure is below minimum value, check valve clearances and parts associated with combustion chamber (valve, valve seat, piston, piston ring, cylinder bore, cylinder head, cylinder head gasket). After the checking, measure compression pressure again.
- If some cylinders have low compression pressure, pour small amount of engine oil into the spark plug hole of the cylinder to re-check it for compression.
- If the added engine oil improves the compression, the piston rings may be worn or damaged. Check the piston rings and replace if necessary.
- If the compression pressure remains at low level despite the addition of engine oil, the valves may be malfunctioning. Check the valves for damage. Replace the valve or valve seat accordingly.

COMPRESSION PRESSURE

< PERIODIC MAINTENANCE >

- If two adjacent cylinders have respectively low compression pressure and their compression remains low even after the addition of engine oil, the head gasket is leaking. In such a case, replace the cylinder head gasket.
8. Install spark plug, ignition coil and harness connectors. Refer to [EM-19. "Removal and Installation"](#).

A

EM

C

D

E

F

G

H

I

J

K

L

M

N

O

P

AIR CLEANER AND AIR DUCT

< REMOVAL AND INSTALLATION >

REMOVAL AND INSTALLATION

AIR CLEANER AND AIR DUCT

Exploded View

INFOID:0000000011279945

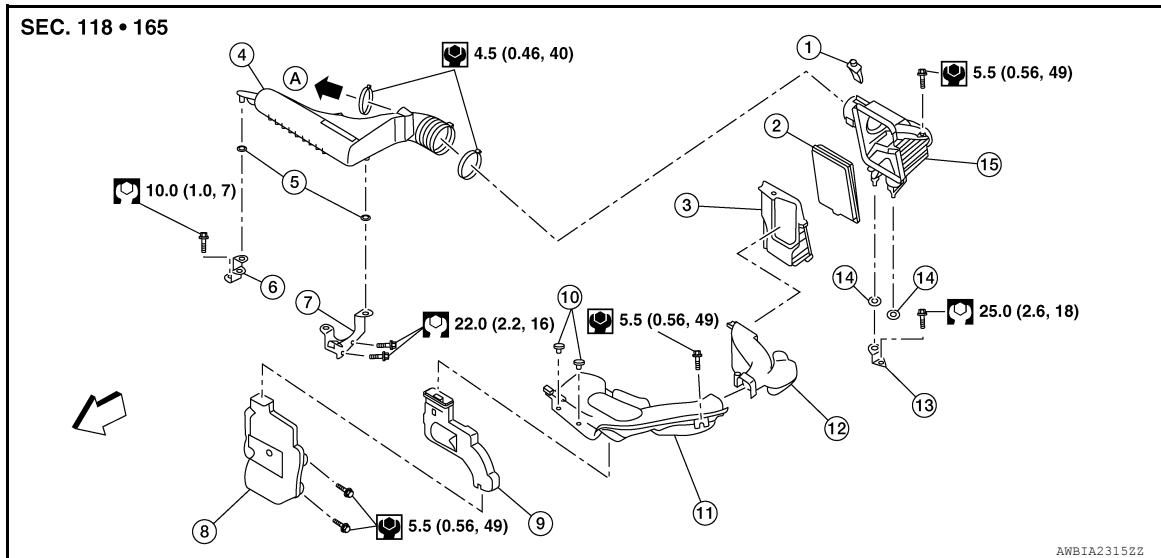

- | | | |
|--|------------------------------|------------------------------|
| 1. Mass air flow sensor | 2. Air cleaner filter | 3. Air cleaner case (lower) |
| 4. Air duct assembly (aft) | 5. Grommet | 6. Resonator bracket (front) |
| 7. Resonator bracket (rear) | 8. Resonator | 9. Air duct |
| 10. Mounting clip | 11. Air duct assembly (fore) | 12. Air cleaner case duct |
| 13. Air cleaner bracket | 14. Grommet | 15. Air cleaner case (upper) |
| A. To Electric throttle control actuator | ← Front | |

Removal and Installation

INFOID:0000000011279946

REMOVAL

1. Remove cowl top extension. Refer to [EXT-25. "Removal and Installation"](#).
2. Remove air cleaner filter. Refer to [EM-18. "Removal and Installation"](#).
3. Remove air duct assembly from air cleaner case (lower).
4. Remove air cleaner case (lower).
5. Disconnect harness connector from mass air flow sensor.
6. Remove air cleaner case (upper).
7. Remove mass air flow sensor from air cleaner case (upper) (if necessary).

CAUTION:

Handle the mass air flow sensor with care.

- Do not shock mass air flow sensor
- Do not disassemble mass air flow sensor
- Do not touch the internal sensor

AIR CLEANER AND AIR DUCT

< REMOVAL AND INSTALLATION >

8. Separate air cleaner case (lower) (2) from air cleaner case duct (1) and air duct assembly (fore) (3).
 - Pull to the direction of the arrow and detach lock (B).
 - Detach the snap fits (C).

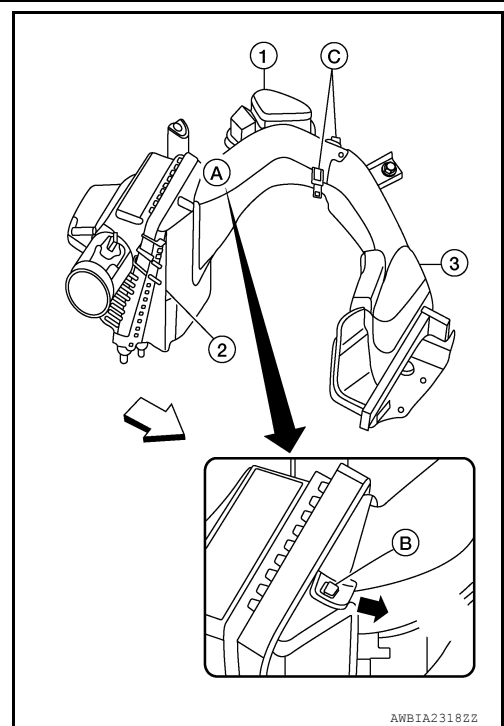

- Lift up to separate the air cleaner case duct (1) from the air cleaner case (lower) (2) and the air duct assembly (fore) (3).

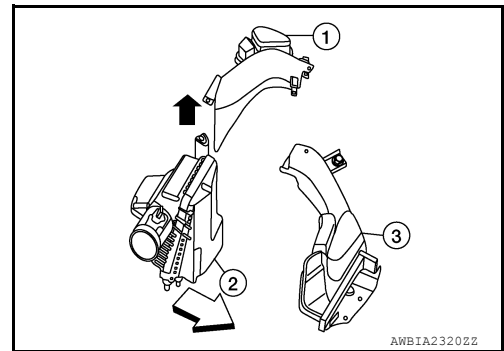

INSTALLATION

Installation is in the reverse order of removal.

- Align mating marks (C) of air duct assembly (B) with air cleaner case (upper) (A) as shown.

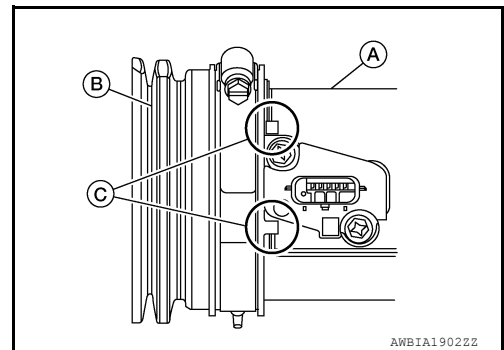

AIR CLEANER AND AIR DUCT

< REMOVAL AND INSTALLATION >

- Align mating marks (C) of air duct assembly (A) with electric throttle control actuator (B) as shown.

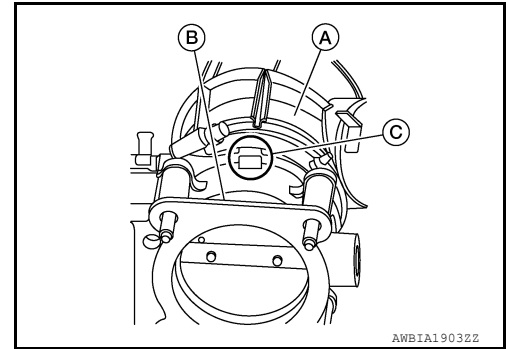

INFOID:000000011279947

Inspection

INSPECTION AFTER REMOVAL

Inspect air duct and resonator assembly for cracks or tears.

- If anything found, replace air duct and resonator assembly.

INTAKE MANIFOLD

< REMOVAL AND INSTALLATION >

INTAKE MANIFOLD

Exploded View

INFOID:000000011350509

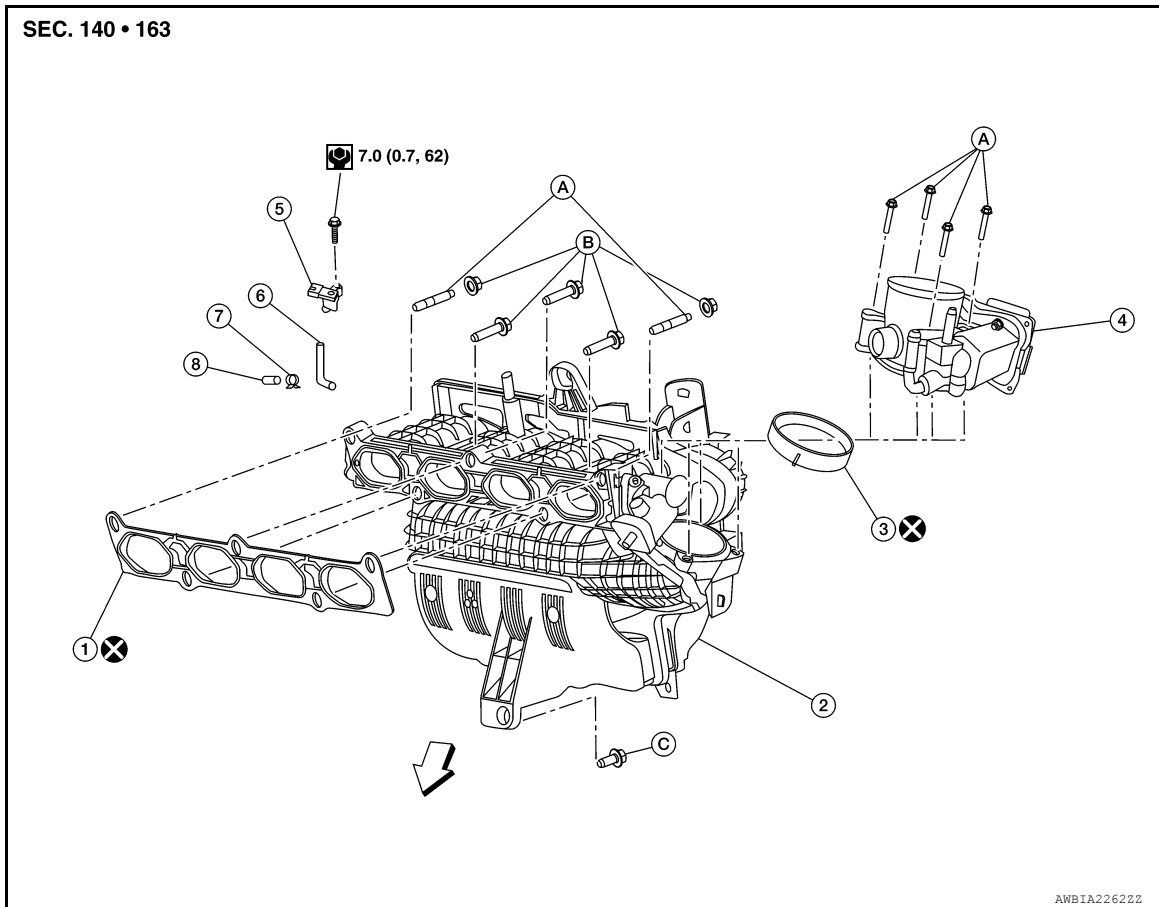

- | | | |
|---------------------------------------|---------------------------------|--|
| 1. Intake manifold gasket | 2. Intake manifold | 3. Electric throttle control actuator O-ring |
| 4. Electric throttle control actuator | 5. Map sensor (California only) | 6. Map hose (California only) |
| 7. Clamp | 8. Cap (except California) | A. Refer to INSTALLATION |
| B. Refer to INSTALLATION | C. Refer to INSTALLATION | ← Front |

Removal and Installation

INFOID:000000011350510

REMOVAL

WARNING:

To avoid the danger of being scalded, do not drain the coolant when the engine is hot.

NOTE:

When removing components such as hoses, tubes/lines, etc., cap or plug openings to prevent fluid from spilling.

1. Disconnect battery negative terminal.
2. Release the fuel pressure. Refer to [EC-147, "Work Procedure"](#).
3. Partially drain engine coolant. Refer to [CO-8, "Draining"](#).
4. Remove the air cleaner case assembly and air duct hose and resonator assembly. Refer to [EM-26, "Removal and Installation"](#).
5. Remove cowl top finisher. Refer to [EXT-25, "Exploded View"](#).
6. Disconnect the PCV hose from the rocker cover.
7. Disconnect the EVAP hose and EVAP canister purge volume control solenoid.
8. Disconnect the brake booster vacuum hose from the intake manifold.

INTAKE MANIFOLD

< REMOVAL AND INSTALLATION >

9. Disconnect the fuel quick connector from the fuel tube assembly. Refer to [EM-45, "Exploded View"](#).
10. Disconnect the water hoses from the electric throttle control actuator.

NOTE:

When removing only intake manifold, position electric throttle control actuator aside without disconnecting the water hose.

11. Loosen bolts in reverse order as shown, then remove electric throttle control actuator and electric throttle actuator gasket.

CAUTION:

Handle carefully to avoid any damage.

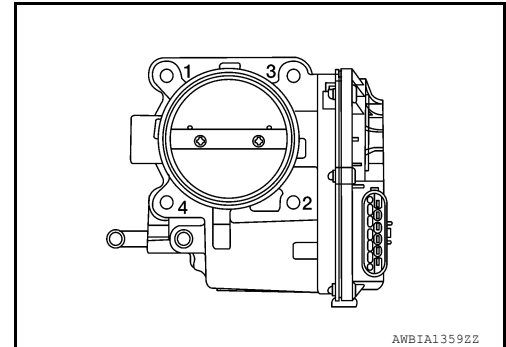

12. Disconnect harness connectors from the tumble control valve, tumble control valve position sensor, and power valve motor.

13. Remove front exhaust tube and exhaust gasket. Refer to [EX-5, "Exploded View"](#).

14. Remove the bolts and nuts in the reverse order shown and remove the intake manifold assembly with gasket.

CAUTION:

Cover engine openings to prevent entry of foreign materials.

NOTE:

Disregard No. 6 when loosening.

15. Remove tumble control valve position sensor from intake manifold (if necessary).

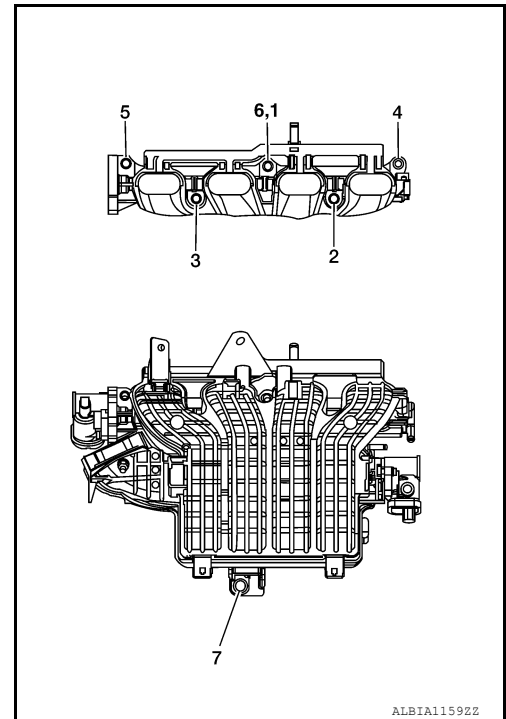

INSTALLATION

Installation is in the reverse order of removal. Follow the tightening sequences and specifications below and perform the following:

- Add engine coolant (if necessary). Refer to [CO-9, "Refilling"](#).
- Perform the "Throttle Valve Closed Position Learning" when harness connector of electric throttle control actuator is disconnected. Refer to [EC-143, "Work Procedure"](#).
- Perform the "Idle Air Volume Learning" and "Throttle Valve Closed Position Learning" when electric throttle control actuator is replaced. Refer to [EC-144, "Work Procedure"](#) (Idle Air Volume Learning) and [EC-143, "Work Procedure"](#) (Throttle Valve Closed Position Learning).

Intake Manifold

1. Securely install intake manifold gasket to the mounting groove.

CAUTION:

Do not reuse intake manifold gasket.

2. If studs were removed, install them and tighten to specification.

INTAKE MANIFOLD

< REMOVAL AND INSTALLATION >

Studs : 9.4 N·m (0.96 kg-m, 83 in-lb)

3. Tighten in numerical order as shown.

CAUTION:

After tightening the five bolts in the order shown, the 1, 6 position designates that the first bolt tightened is to be retightened to specification.

Bolts 1, 2, 3, 4, 5, 6 : 25.0 N·m (2.6 kg-m, 18 ft-lb)

Nuts 4, 5 : 25.0 N·m (2.6 kg-m, 18 ft-lb)

Bolt 7 : 45.0 N·m (4.6 kg-m, 33 ft-lb)

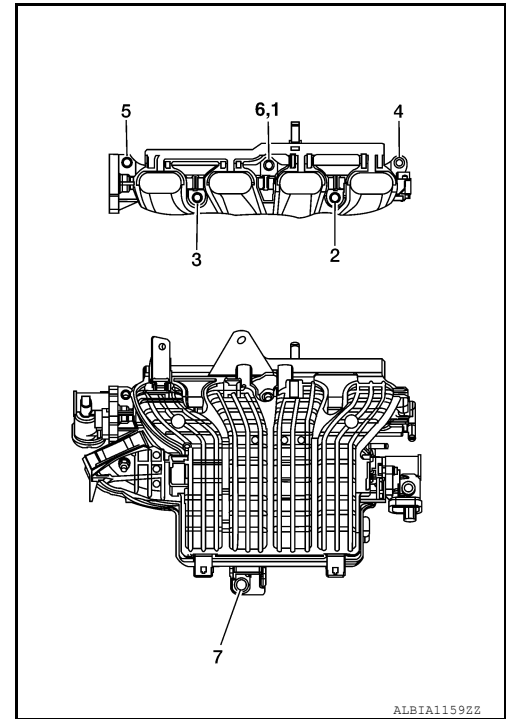

Electric Throttle Control Actuator

1. Install a new gasket on the electric throttle control actuator.

CAUTION:

Do not reuse electric throttle control actuator gasket.

2. Tighten the bolts of electric throttle control actuator in numerical order as shown.

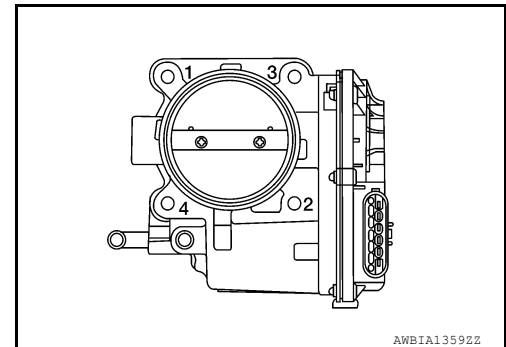

INSPECTION AFTER INSTALLATION

Make sure there are no fuel leaks at connections as follows:

1. Apply fuel pressure to fuel lines by turning ignition switch ON (with engine stopped). Then check for fuel leaks at connections.

NOTE:

Use mirrors for checking on connections out of the direct line of sight.

2. Start the engine and rev it up and check for fuel leaks at connections.

WARNING:

Do not touch engine immediately after stopping as engine is extremely hot.

EXHAUST MANIFOLD AND THREE WAY CATALYST

< REMOVAL AND INSTALLATION >

EXHAUST MANIFOLD AND THREE WAY CATALYST

Exploded View

INFOID:000000011279950

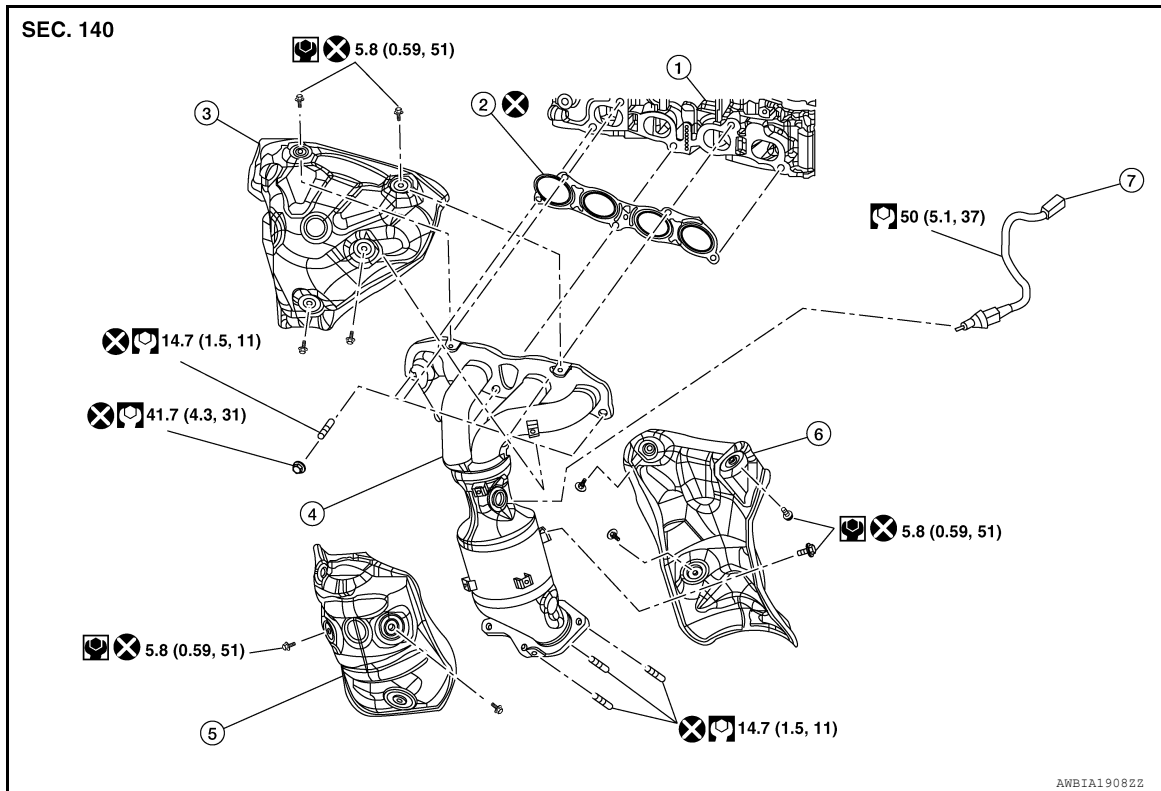

1. Cylinder head
2. Exhaust manifold and three way catalyst gasket
3. Exhaust manifold cover (upper)
4. Exhaust manifold and three way catalyst
5. Exhaust manifold cover (lower front)
6. Exhaust manifold cover (lower rear)
7. Air fuel ratio (A/F) sensor 1

Removal and Installation

INFOID:000000011279951

REMOVAL

1. Disconnect battery negative terminal.
2. Remove A/C line bracket bolt (A).

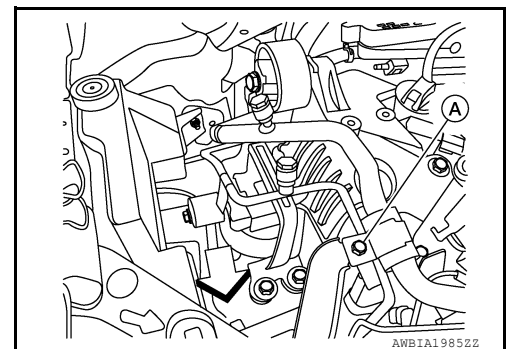

3. Remove engine under cover. Refer to [EXT-37, "ENGINE UNDER COVER : Removal and Installation"](#).
4. Remove the oil level gauge and oil level gauge guide. Refer to [EM-97, "Exploded View"](#).
5. Remove harness ground wire bolt from generator bracket.
6. Remove the generator. Refer to [CHG-20, "Removal and Installation"](#).
7. Disconnect harness connector from air fuel ratio (A/F) sensor 1.

EXHAUST MANIFOLD AND THREE WAY CATALYST

< REMOVAL AND INSTALLATION >

8. Remove the air fuel ratio (A/F) sensor 1 using Tool, (if necessary).

Tool numbers : KV991J0050 (J-44626)

CAUTION:

- Clean exhaust manifold and three way catalyst port securing air fuel ratio (A/F) sensor 1 with anti-seize lubricant, or equivalent.
 - Be careful not to damage air fuel ratio (A/F) sensor.
 - Discard any air fuel ratio (A/F) sensor which has been dropped from a height of more than 0.5 m (19.7 in) onto a hard surface such as a concrete floor; replace with a new one.
9. Detach front exhaust tube from exhaust manifold and three way catalyst. Discard the gasket. Refer to [EX-5, "Exploded View"](#).
 10. Remove the exhaust manifold cover (upper).
 11. Loosen the exhaust manifold and three way catalyst nuts in the reverse order as shown.

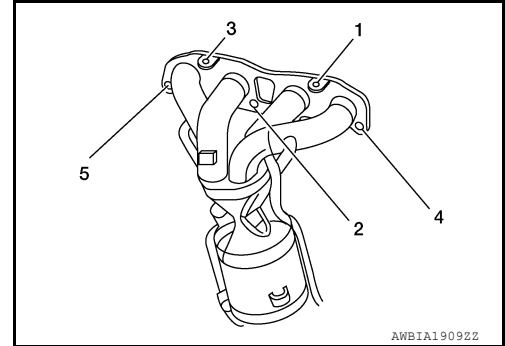

12. Remove exhaust manifold and three way catalyst.
13. Remove exhaust manifold and three way catalyst gasket.
14. Remove the exhaust manifold cover (lower front) (if necessary).
15. Remove the exhaust manifold cover (lower rear) (if necessary).

INSPECTION AFTER REMOVAL

Surface Distortion

- Check the flatness of exhaust manifold and three way catalyst using suitable tools (A/B).

NOTE:

Place the suitable tool (A) diagonally and measure in several locations.

Limit : 0.3 mm (0.012 in)

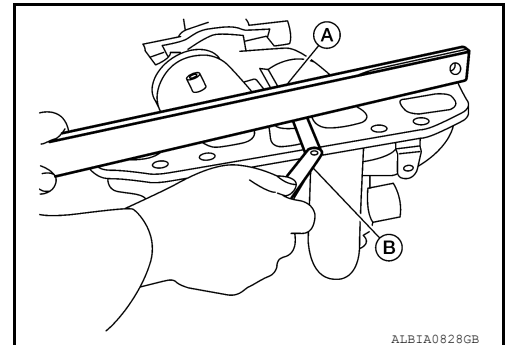

INSTALLATION

Exhaust Manifold

1. Install studs in cylinder head and exhaust manifold (if removed). Then tighten to specification.

CAUTION:

Do not reuse cylinder head gasket or exhaust manifold studs.

EXHAUST MANIFOLD AND THREE WAY CATALYST

< REMOVAL AND INSTALLATION >

2. Install exhaust manifold cover (lower rear) (if removed) and bolts. Then tighten the bolts to specification in the numerical order shown.

CAUTION:

Do not reuse bolts.

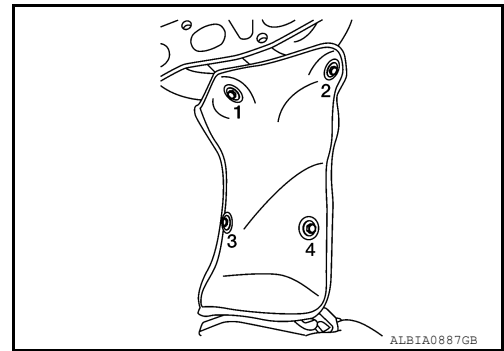

3. Install the exhaust manifold and three way catalyst, along with the exhaust manifold and three way catalyst gasket. Then tighten the nuts to specification in the numerical order shown.

CAUTION:

Do not reuse gasket.

⇐ : Front

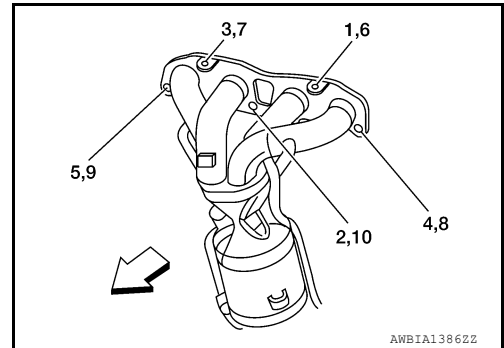

4. Install the exhaust manifold cover (lower front) and bolts. Then tighten the bolts to specification in the numerical order shown.

CAUTION:

Do not reuse bolts.

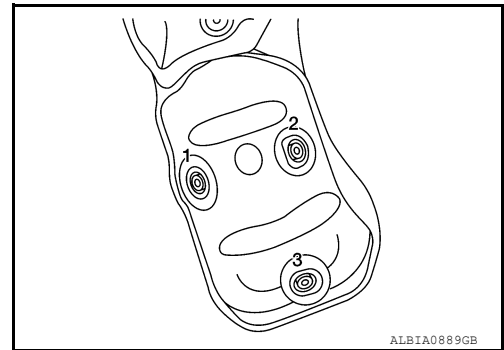

5. Clean exhaust manifold and three way catalyst port securing air fuel ratio (A/F) sensor 1 with Tool.

Tool numbers : (J-43897-18)

6. Install the air fuel ratio (A/F) sensor 1 using Tool and tighten to specification.

Tool numbers : KV991J0050 (J-44626)

CAUTION:

- Clean exhaust manifold and three way catalyst port securing air fuel ratio (A/F) sensor 1 with anti-seize lubricant, or equivalent.
- Be careful not to damage air fuel ratio (A/F) sensor 1.
- Discard any air fuel ratio (A/F) sensor 1 which has been dropped from a height of more than 0.5 m (19.7 in) onto a hard surface such as a concrete floor; replace with a new one.
- Do not over-tighten the air fuel ratio (A/F) sensor 1. Doing so may cause damage to the air fuel ratio (A/F) sensor 1, resulting in a malfunction and the MIL coming on.

EXHAUST MANIFOLD AND THREE WAY CATALYST

< REMOVAL AND INSTALLATION >

7. Install the exhaust manifold cover (upper). Then tighten the bolts to specification in the numerical order shown.

CAUTION:

Do not reuse bolts.

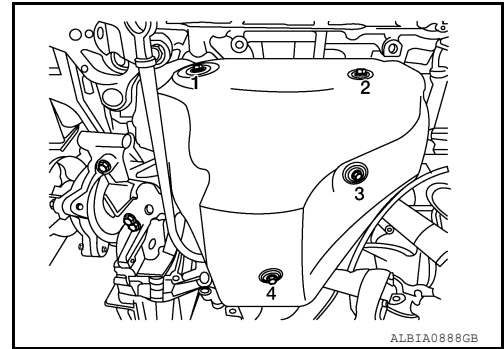

A

EM

C

D

E

F

G

H

I

J

K

L

M

N

O

P

OIL PAN AND OIL STRAINER

< REMOVAL AND INSTALLATION >

OIL PAN AND OIL STRAINER

Exploded View

INFOID:000000011358721

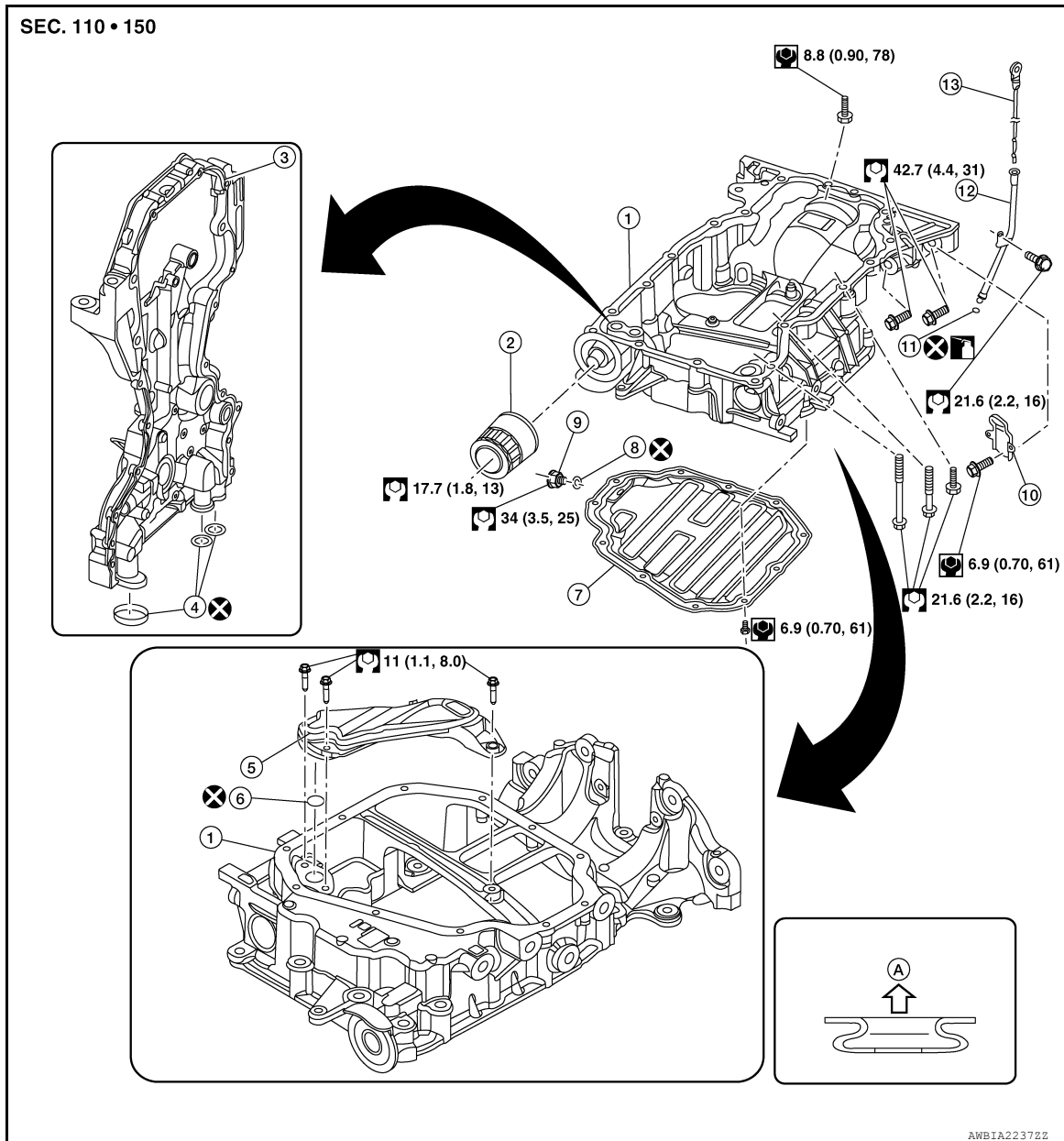

- | | | |
|----------------------|-----------------------|---------------------------|
| 1. Oil pan (upper) | 2. Oil filter | 3. Front cover |
| 4. O-ring | 5. Oil strainer | 6. O-ring |
| 7. Oil pan (lower) | 8. Washer | 9. Drain plug |
| 10. Rear cover plate | 11. O-ring | 12. Oil level gauge guide |
| 13. Oil level gauge | A. To oil pan (lower) | |

Removal and Installation

INFOID:000000011279953

REMOVAL

WARNING:

To avoid danger of being scalded, do not drain engine oil when engine is hot.

1. Drain engine oil. Refer to [LU-8, "Draining"](#).
2. Remove the oil filter. Refer to [LU-10, "Removal and Installation"](#).

OIL PAN AND OIL STRAINER

< REMOVAL AND INSTALLATION >

3. Remove fender protector (RH). Refer to [EXT-28, "FENDER PROTECTOR : Removal and Installation"](#).
4. Remove the front driveshaft (RH). Refer to [FAX-23, "Removal and Installation \(RH\)"](#).
5. Remove the front exhaust tube and gaskets. Refer to [EX-5, "Exploded View"](#).
6. Remove bolt (A) securing oil level gauge (2).
7. Remove oil level gauge (1), oil level gauge guide (2), and O-ring (3).

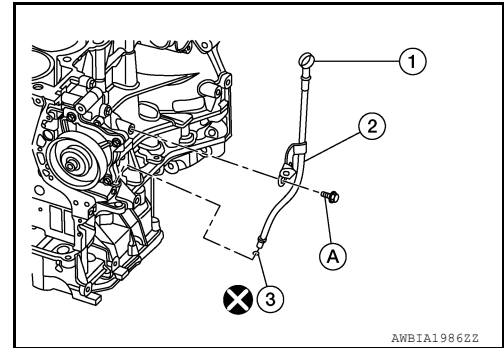

8. Remove the power steering gear bolts and support the power steering gear. Refer to [ST-14, "Removal and Installation"](#).
9. Remove the rear engine mount torque rod bracket. Refer to [EM-86, "Exploded View"](#).
10. Remove the front suspension member for clearance to remove the oil pan. Refer to [FSU-22, "Removal and Installation"](#).
11. On models equipped with AWD, remove transfer assembly. Refer to [DLN-71, "Removal and Installation"](#).
12. Disconnect the A/C compressor harness connector.
13. Remove the A/C compressor bolts, position the A/C compressor aside and support. Refer to [HA-29, "Removal and Installation"](#).
14. Remove the lower oil pan bolts in the reverse order as shown.

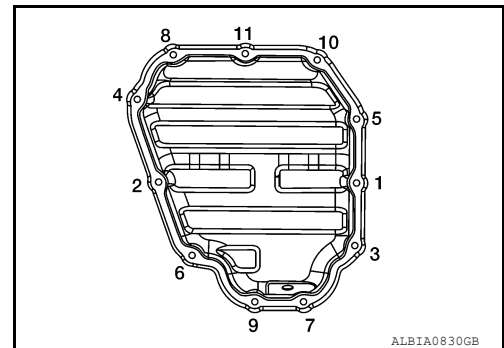

15. Remove the lower oil pan using Tool (A).

CAUTION:

Be careful not to damage the mating surfaces.

NOTE:

In areas where the cutter is difficult to use, use a plastic hammer to lightly tap (1) the cutter where the liquid gasket is applied. Use a plastic hammer to slide (2) the cutter by tapping on the side.

Tool number : KV10111100 (J-37228)

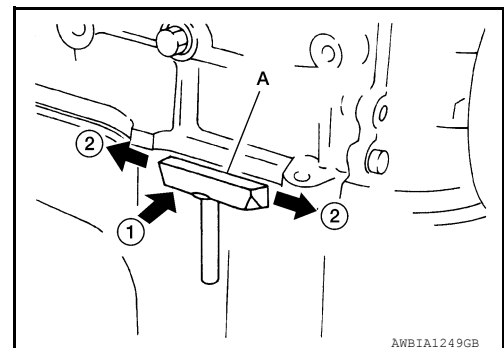

OIL PAN AND OIL STRAINER

< REMOVAL AND INSTALLATION >

16. Remove the oil strainer bolts in the reverse order as shown then remove the oil strainer.

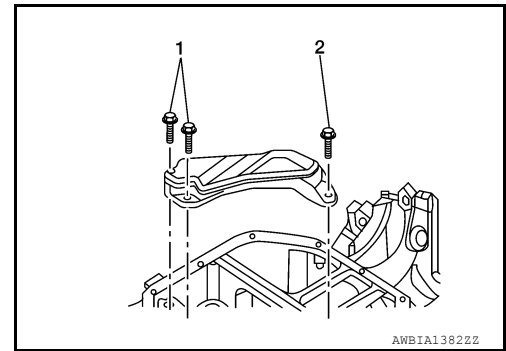

17. Remove rear cover plate and engine-to transaxle bolts.
18. Loosen the upper oil pan bolts in the order shown.

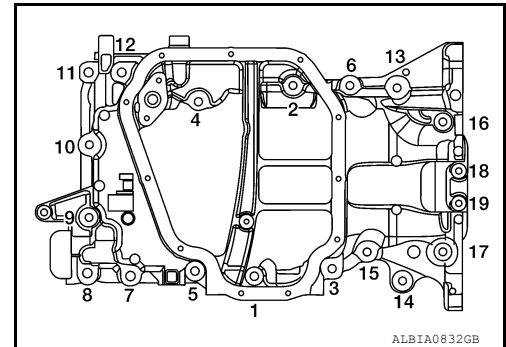

19. Remove upper oil pan using Tool (A).
• Remove the three O-rings from the upper oil pan and front cover.
- CAUTION:**
Be careful not to damage the mating surfaces.
- NOTE:**
In areas where the cutter is difficult to use, use a plastic hammer to lightly tap (1) the cutter where the liquid gasket is applied. Use a plastic hammer to slide (2) the cutter by tapping on the side.

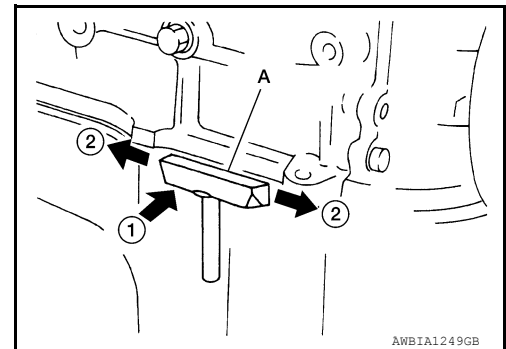

Tool number : KV10111100 (J-37228)

INSPECTION AFTER REMOVAL

Clean the oil strainer screen to remove any foreign material.

INSTALLATION

1. Apply Genuine Silicone RTV Sealant or equivalent to the upper oil pan at the specified sealant bead diameter (A) as shown. Refer to [GI-22, "Recommended Chemical Products and Sealants"](#).

Sealant bead diameter (A) : 4.0 - 5.0 mm (0.157 - 0.197 in)

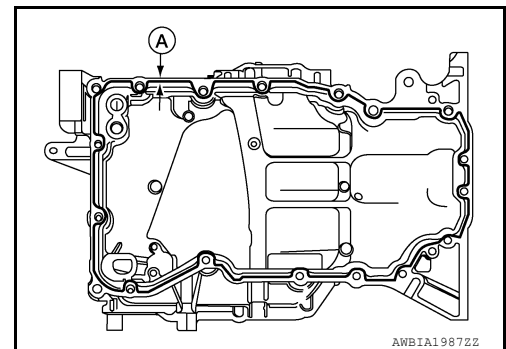

CAUTION:

- Be sure liquid gasket application surface is free from dust, grease, and water.
- Install two new O-rings in the upper oil pan and a new O-ring in the front cover.
- Do not reuse O-rings.

OIL PAN AND OIL STRAINER

< REMOVAL AND INSTALLATION >

- Be sure to apply liquid gasket to the outside of bolt holes 1, 2, and 4.

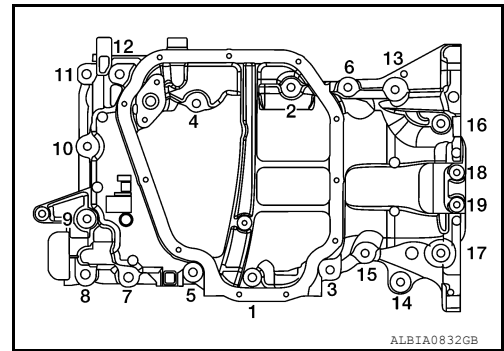

- Be sure to apply liquid gasket without breaks or overlap.
- Installation should be done within 5 minutes after applying liquid gasket.
- Do not fill the engine with engine oil for at least 30 minutes after the components are installed to allow the liquid gasket to cure.

2. Install the upper oil pan to the block and tighten the upper oil pan bolts to specification in the order shown.

CAUTION:

Install upper oil pan bolts in the same position from which they were removed.

All bolts except 18 and 19 : 21.6 N·m (2.2 kg-m, 16 ft-lb)

Bolts 18 and 19 : 8.8 N·m (0.90 kg-m, 78 in-lb)

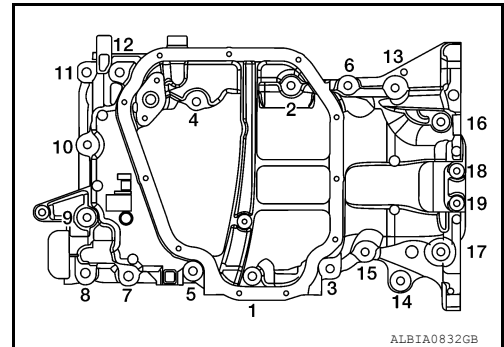

3. Apply Genuine Silicone RTV Sealant or equivalent to the lower oil pan at the specified sealant bead diameter (A) as shown. Refer to [GI-22, "Recommended Chemical Products and Sealants"](#).

CAUTION:

- Be sure liquid gasket application surface is free from dust, grease, and water.
- Be sure to apply liquid gasket to the inside of all bolt holes.
- Be sure to apply liquid gasket without breaks or overlap.
- Installation should be done within 5 minutes after applying liquid gasket.
- Do not fill the engine with engine oil for at least 30 minutes after the components are installed to allow the liquid gasket to cure.

Sealant bead diameter (A) : 4.0 - 5.0 mm (0.157 - 0.197 in)

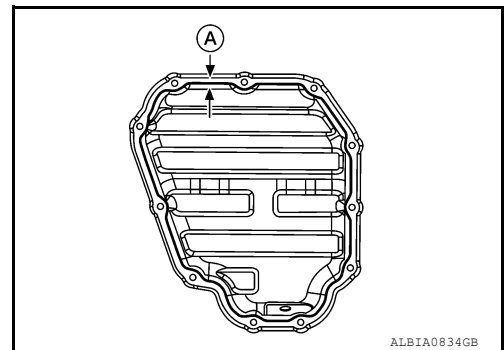

4. Install the lower oil pan to the upper oil pan and tighten the lower oil pan bolts to specification in the numerical order shown.

CAUTION:

OIL PAN AND OIL STRAINER

< REMOVAL AND INSTALLATION >

Install new drain plug washer.

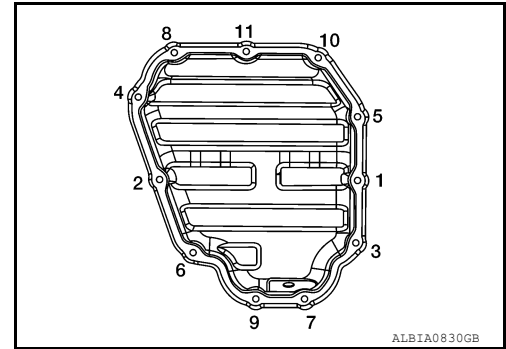

5. Install oil level gauge (1), oil level gauge guide (2), and O-ring (3).

CAUTION:

Do not reuse oil level gauge guide O-ring.

Bolt (A) : 21.6 N·m (2.2 kg-m, 16 ft-lb)

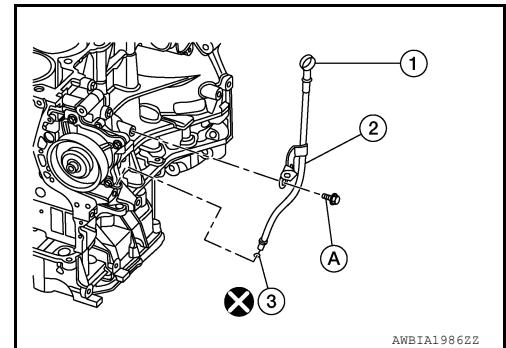

6. Installation of the remaining components is in the reverse order of removal.

INSPECTION AFTER INSTALLATION

Check for engine oil leaks with the engine at operating temperature and running at idle. Refer to [LU-7, "Inspection"](#).

IGNITION COIL

< REMOVAL AND INSTALLATION >

IGNITION COIL

Exploded View

INFOID:000000011279954

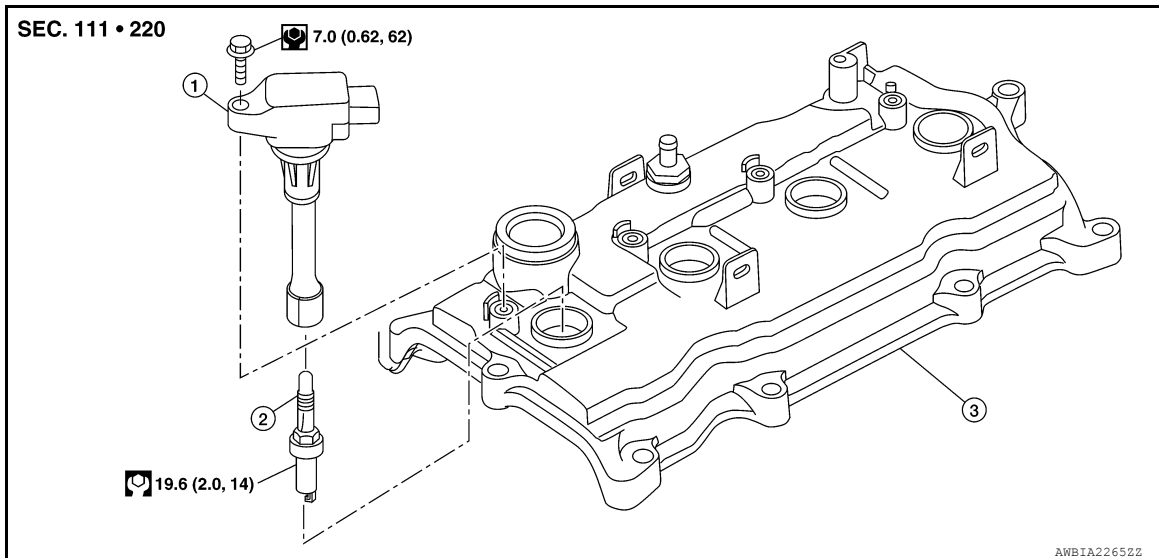

1. Ignition coil

2. Spark plug

3. Rocker cover

Removal and Installation

INFOID:000000011279955

REMOVAL

1. Remove air cleaner and air duct. Refer to [EM-26. "Exploded View"](#) .
2. Disconnect the harness connector from the ignition coil.
3. Remove the ignition coil.

CAUTION:

Discard any ignition coil which has been dropped or shocked.

INSTALLATION

Installation is in the reverse order of removal.

ROCKER COVER

< REMOVAL AND INSTALLATION >

ROCKER COVER

Exploded View

INFOID:000000011279956

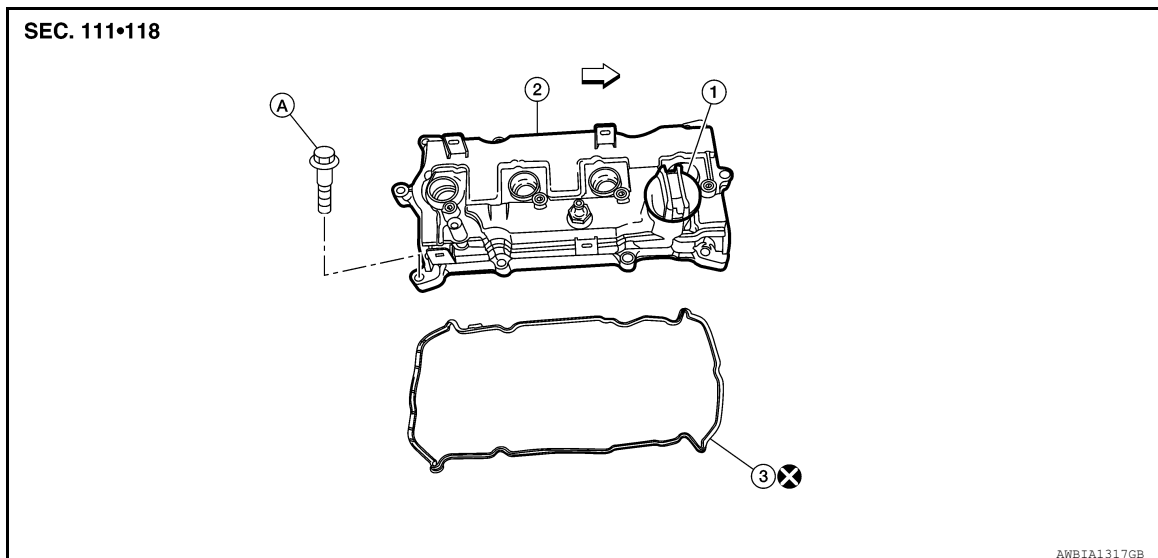

1. Oil filler cap 2. Rocker cover 3. Rocker cover gasket
A. Refer to INSTALLATION ⇐ Engine front

Removal and Installation

INFOID:000000011279957

REMOVAL

1. Remove intake manifold. Refer to [EM-29, "Removal and Installation"](#).
2. Remove wheel and tire (RH) using a power tool.
3. Remove engine under cover. Refer to [EXT-37, "ENGINE UNDER COVER : Removal and Installation"](#).
4. Remove fender protector side cover. Refer to [EXT-28, "FENDER PROTECTOR : Exploded View"](#).
5. Remove drive belt. Refer to [EM-15, "Removal and Installation"](#).
6. Use a suitable jack (A) to securely support the bottom of the engine (1) and the transaxle assembly (2).

CAUTION:

Put a piece of wood or an equivalent as the supporting surface and secure in a stable condition.

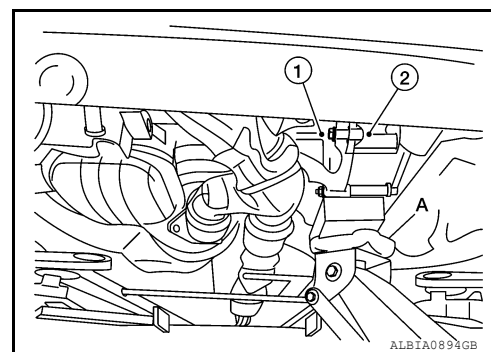

7. Remove the RH engine mount torque rod. Refer to [EM-86, "Exploded View"](#).

ROCKER COVER

< REMOVAL AND INSTALLATION >

8. Remove A/C line bracket bolt.

← : Engine front

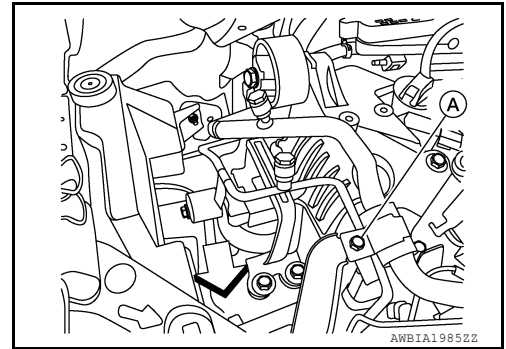

9. Remove harness grounds from engine mounting bracket (RH).
10. Remove harness retainers from engine mounting bracket (RH).
11. Remove the engine mounting bracket (RH). Refer to [EM-86. "Exploded View"](#)
12. Remove the engine mounting bracket (LH). Refer to [EM-86. "Exploded View"](#)
13. Disconnect the PCV hose.
14. Disconnect harness connector from intake valve timing control solenoid valve. Refer to [EM-49. "Exploded View"](#)
15. Disconnect harness connector from intermediate valve timing control solenoid valve. Refer to [EM-49. "Exploded View"](#)
16. Disconnect harness connector from exhaust valve timing control solenoid valve. Refer to [EM-49. "Exploded View"](#)
17. Disconnect harness connector from camshaft position sensors. Refer to [EM-69. "Exploded View"](#).
18. Remove the spark plugs. Refer to [EM-19. "Removal and Installation"](#).
19. Loosen the bolts in the numerical order as shown using power tool.
20. Remove the rocker cover and the rocker cover gasket. Discard the rocker cover gasket.
CAUTION:
Do not reuse the rocker cover gasket.
21. Remove the oil filler cap, (if necessary).

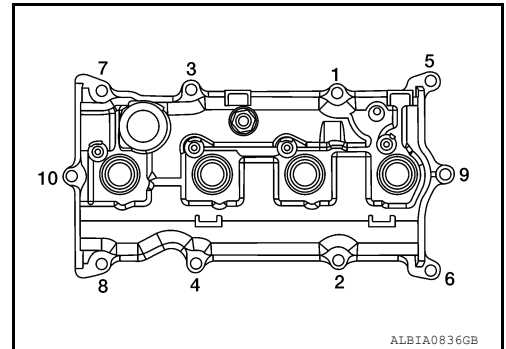

INSTALLATION

ROCKER COVER

< REMOVAL AND INSTALLATION >

1. Apply liquid gasket to the position shown (A) with the following procedure:
 - a. Apply liquid gasket to joint part of No.1 camshaft bracket (1) and cylinder head.
 - b. Apply liquid gasket in a 90° degree angle (B).
 - **Use Genuine Silicone RTV Sealant, or equivalent. Refer to [GI-22. "Recommended Chemical Products and Sealants"](#).**

(B) : 10 mm (0.39 in)

(C) : 4 mm (0.16 in)

(D) : 5 mm (0.20 in)

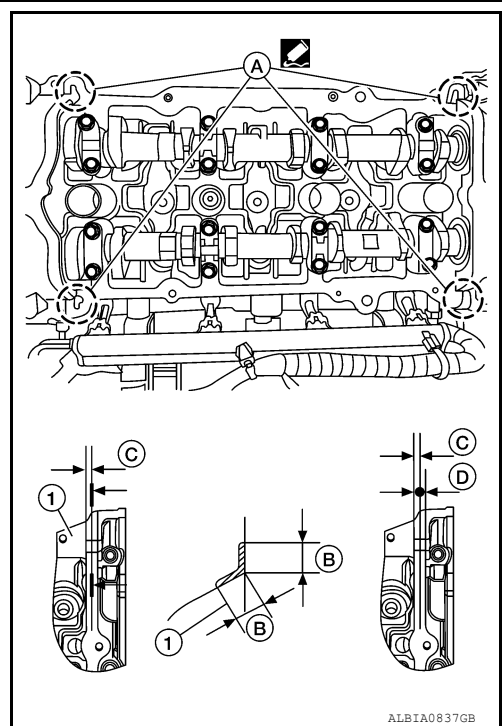

2. Install rocker cover gasket to rocker cover.
NOTE:
The rocker cover gasket must be securely installed in the groove in the rocker cover.
3. Install the rocker cover and rocker cover gasket onto the cylinder head.
4. Tighten the rocker cover bolts to specification in two steps in the order shown.

Step 1 : 1.96 N·m (0.20 kg-m, 17 in-lb)

Step 2 : 8.33 N·m (0.85 kg-m, 74 in-lb)

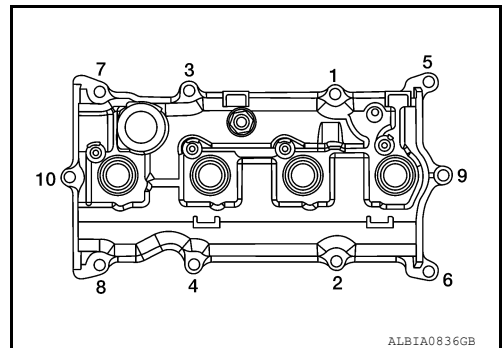

5. Installation of the remaining components is in the reverse order of removal.
6. Inspect for engine oil leaks. Refer to [LU-7. "Inspection"](#).

FUEL INJECTOR AND FUEL TUBE

< REMOVAL AND INSTALLATION >

FUEL INJECTOR AND FUEL TUBE

Exploded View

INFOID:000000011279958

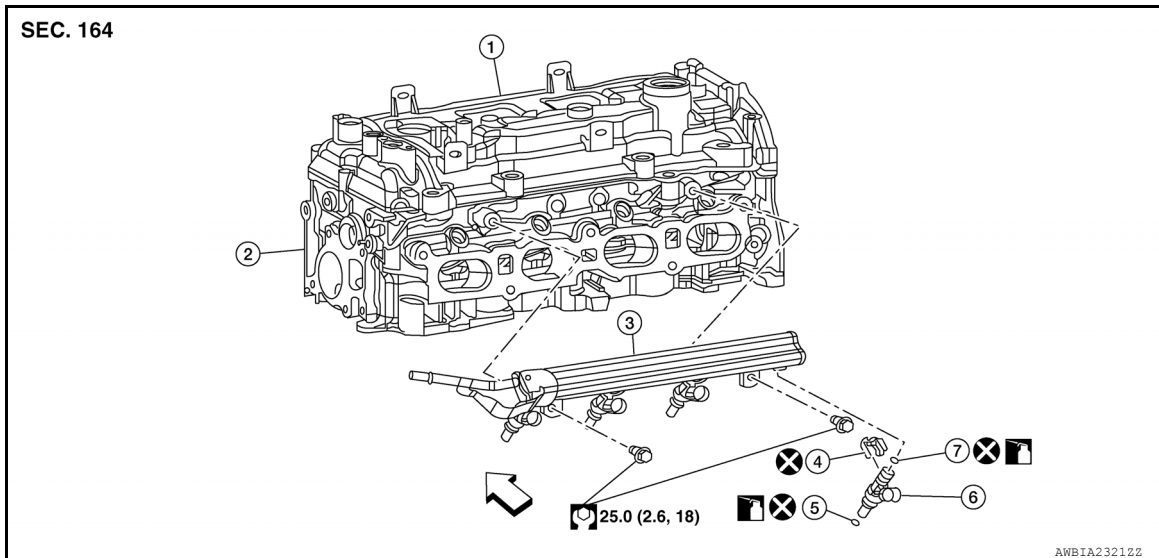

- | | | |
|-------------------|-------------------|------------------|
| 1. Rocker cover | 2. Cylinder head | 3. Fuel tube |
| 4. Clip | 5. O-ring (green) | 6. Fuel injector |
| 7. O-ring (black) | ↵ Front | |

Removal and Installation

INFOID:000000011279959

WARNING:

- Put a "CAUTION: FLAMMABLE" sign in the workshop.
- Be sure to work in a well ventilated area and furnish workshop with a CO2 fire extinguisher.
- Do not smoke while servicing fuel system. Keep open flames and sparks away from the work area.

CAUTION:

- Apply new engine oil before installing the parts, as shown above.
- Do not remove or disassemble parts unless instructed as shown.

REMOVAL

1. Release the fuel pressure. Refer to [EC-147, "Work Procedure"](#).
2. Remove intake manifold. Refer to [EM-29, "Removal and Installation"](#).
3. Disengage red locking clip on quick connector.
4. Disconnect the fuel hose quick connector (1) at the fuel tube side (A).

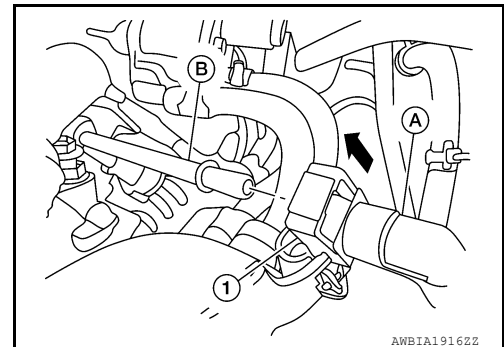

CAUTION:

- Do not pull with lateral force applied. O-ring inside quick connector may be damaged.
- Prepare container and cloth beforehand as fuel will leak out.

FUEL INJECTOR AND FUEL TUBE

< REMOVAL AND INSTALLATION >

- Avoid fire and sparks.
 - Keep parts away from heat source. Especially, be careful when welding is performed around them.
 - Do not expose parts to battery electrolyte or other acids.
 - Do not bend or twist connection between quick connector and fuel feed tube during installation/removal.
 - To keep the connecting portion clean and to avoid damage and foreign materials, cover them completely with plastic bags or something similar.
 - Do not reuse O-ring.
5. Disconnect sub-harness for injectors at engine front side, and remove it from bracket.
 6. Disconnect the fuel injector harness connectors.
 7. Loosen the bolts in the reverse order shown, then remove fuel tube and fuel injectors as an assembly.
 8. Remove the fuel injectors from the fuel tube, (if necessary).
 - a. Release the clip.
 - b. Pull fuel injector straight out of the fuel tube.

CAUTION:

- Be careful not to damage the nozzle.
- Avoid any impact, such as dropping the fuel injector.
- Do not disassemble or adjust the fuel injector.

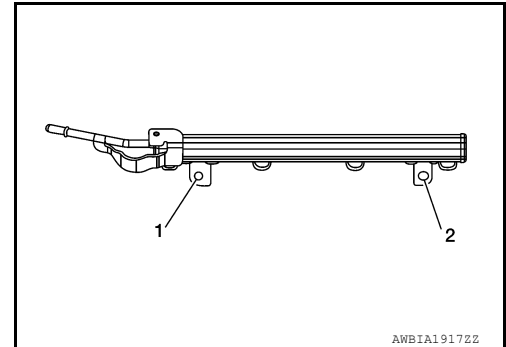

AWBIA1917ZZ

INSTALLATION

1. Install new O-rings on the fuel injector.

CAUTION:

- Do not reuse O-rings.
- Upper and lower O-rings are different. Be careful not to confuse them.

Fuel tube side : Black

Nozzle side : Green

- Handle O-rings with bare hands only. Do not wear gloves.
- Lubricate O-rings with new engine oil.
- Do not clean O-rings with solvent.
- Make sure that O-ring and its mating part are free of foreign material.
- Be careful not to scratch O-rings during installation.
- Do not twist or stretch the O-ring. If the O-ring was stretched while it is attached, do not insert it into the fuel tube immediately.

FUEL INJECTOR AND FUEL TUBE

< REMOVAL AND INSTALLATION >

2. Install the fuel injector (5) into the fuel tube (1) with the following procedure:
 - (2): O-ring (black)
 - (4): O-ring (green)
 - a. Insert the new clip (3) into the clip groove (F) on fuel injector (5).
 - Insert the clip (3) so that protrusion (E) of fuel injector (5) matches cutout (C) of the clip (3).
 - CAUTION:**
 - Do not reuse clip (3), replace it with a new one.
 - Be careful to keep clip from interfering with O-ring. If interference occurs, replace O-ring.
 - b. Insert fuel injector (5) into fuel tube (1) with clip (3) attached.
 - Insert fuel injector (5) so that protrusion (A) of fuel tube (1) matches cut-out (B) of the clip (3).
 - Check that fuel tube flange (G) is securely fixed in flange groove (D) on the clip (3).
 - c. Check that installation is complete by checking that fuel injector (5) does not rotate or come off.

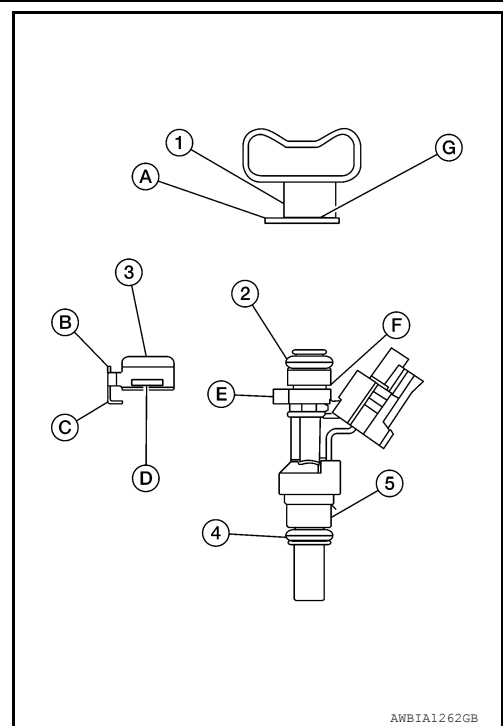

3. Install fuel tube and fuel injector assembly with the following procedure.
 - a. Insert the tip of each fuel injector into intake manifold.
 - b. Tighten the bolts to specification in the numerical order as shown.

CAUTION:

After properly connecting fuel tube assembly to injector and fuel hose, check connection for fuel leaks.

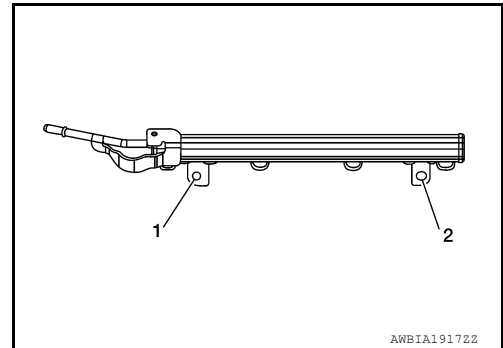

4. Connect the fuel hose quick connector.
 - a. Make sure no foreign substances are deposited in and around the fuel tube and quick connector, and there is no damage to them.
 - b. Thinly apply new engine oil around the fuel tube tip end.
 - c. Align center to insert quick connector straight onto fuel tube.
 - d. Insert fuel tube into quick connector (1) until the spool (B) on fuel tube is inserted completely.
 - e. Engage red locking clip on quick connector.

CAUTION:

- Hold at position (A) as shown, when inserting the fuel tube into the quick connector (1).
- Carefully align to center to avoid inclined insertion to prevent damage to the O-ring inside the quick connector (1).
- Insert the fuel tube until you hear a “click” sound and actually feel the engagement.
- To avoid misidentification of engagement with a similar sound.
- Do not reuse O-ring.
- Ensure that red locking clip is firmly secured.

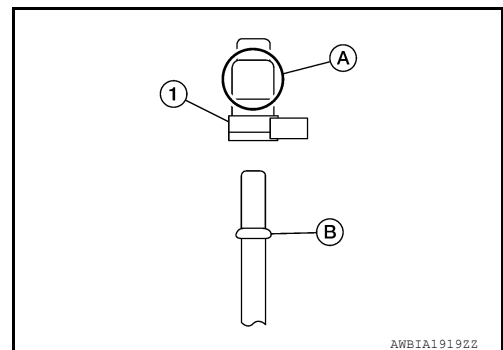

5. Installation of the remaining components is in the reverse order of removal.

FUEL INJECTOR AND FUEL TUBE

< REMOVAL AND INSTALLATION >

INSPECTION AFTER INSTALLATION

Make sure there are no fuel leaks at connections as follows:

1. Apply fuel pressure to fuel lines by turning ignition switch ON (with engine stopped). Then check for fuel leaks at connections.
2. Start the engine and rev it up and check for fuel leaks at connections.
 - Perform procedures for “Throttle Valve Closed Position Learning” after finishing repairs. Refer to [EC-143, "Work Procedure"](#).
 - If electric throttle control actuator is replaced, perform procedures for “Idle Air Volume Learning” after finishing repairs. Refer to [EC-144, "Work Procedure"](#).

WARNING:

Do not touch engine immediately after stopping as engine is extremely hot.

NOTE:

Use mirrors for checking on connections out of the direct line of sight.

TIMING CHAIN

< REMOVAL AND INSTALLATION >

TIMING CHAIN

Exploded View

INFOID:000000011279960

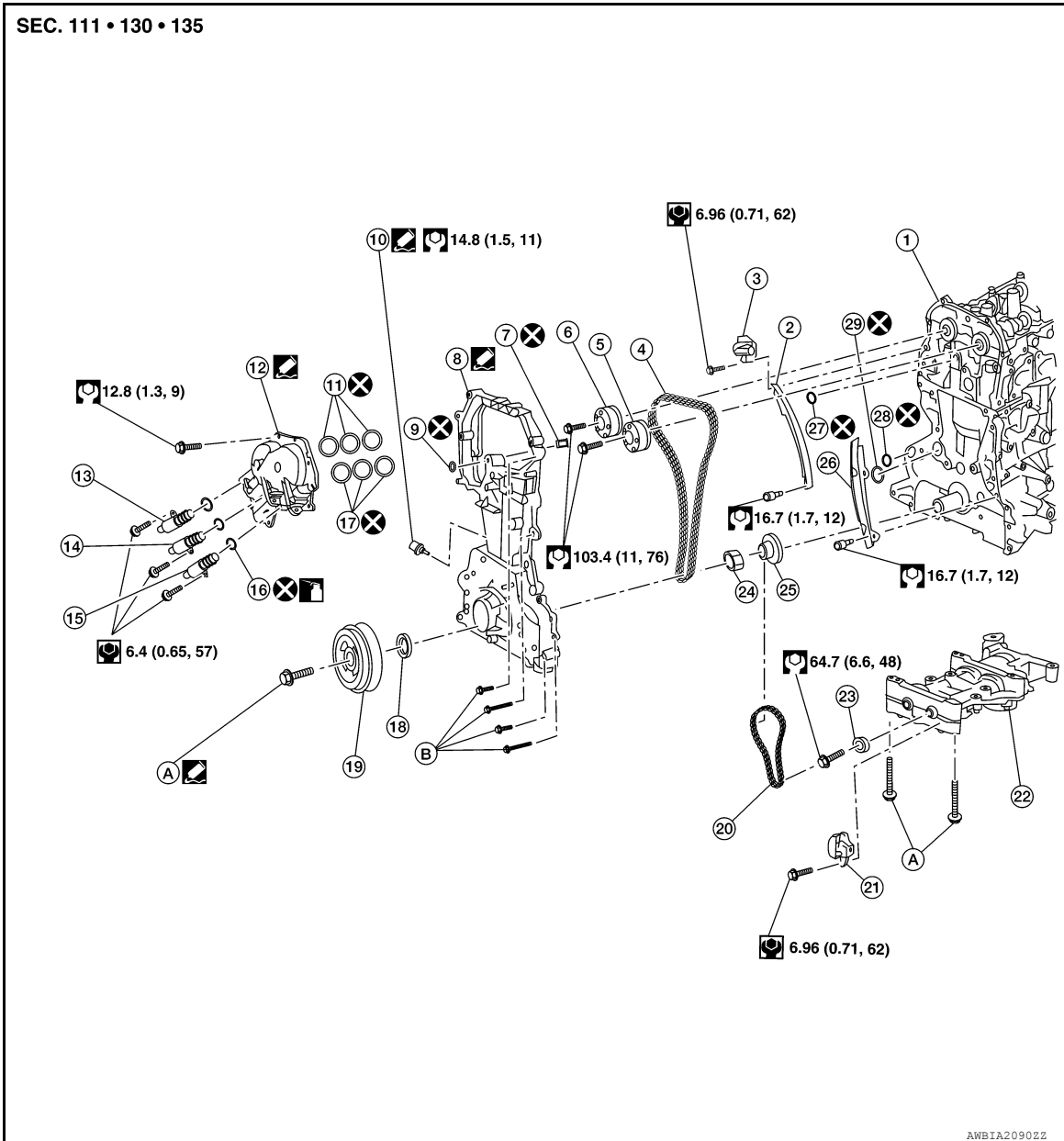

- | | | |
|--|--|---|
| 1. Cylinder block | 2. Timing chain slack guide | 3. Chain tensioner |
| 4. Timing chain | 5. Camshaft sprocket (EXH) | 6. Camshaft sprocket (INT) |
| 7. Oil filter | 8. Front cover | 9. O-ring |
| 10. Oil pressure sensor | 11. Valve timing control cover O-rings | 12. Valve timing control cover |
| 13. Intake valve timing intermediate lock control solenoid valve | 14. Intake valve timing control solenoid valve | 15. Exhaust valve timing control solenoid valve |
| 16. Valve timing control solenoid valve O-rings | 17. Valve timing control cover O-rings | 18. Front oil seal |
| 19. Crankshaft pulley | 20. Balancer unit timing chain | 21. Balancer unit timing chain tensioner |
| 22. Balancer unit | 23. Balancer unit sprocket | 24. Oil pump drive spacer |
| 25. Crankshaft sprocket | 26. Timing chain tension guide | 27. O-ring |

TIMING CHAIN

< REMOVAL AND INSTALLATION >

28. O-ring

B. Refer to INSTALLATION

29. O-ring

A. Refer to INSTALLATION

Removal and Installation

INFOID:000000011279961

CAUTION:

Apply new engine oil to parts as indicated in the illustration before installation.

REMOVAL

1. Remove the engine and transaxle assembly. Refer to [EM-86, "Exploded View"](#).
2. Remove intake manifold. Refer to [EM-29, "Removal and Installation"](#).
3. Remove the drive plate assembly. Refer to [EM-97, "Exploded View"](#).
4. Install engine to a suitable engine stand. Refer to [EM-96, "Setting"](#).
5. Disconnect harness connector from intake valve timing intermediate lock control solenoid valve.
6. Disconnect harness connector from intake valve timing control solenoid valve.
7. Disconnect harness connector from exhaust valve timing control solenoid valve.
8. Remove valve timing control cover.
9. Remove the upper and lower oil pan, oil strainer, and O-ring. Refer to [EM-36, "Removal and Installation"](#).
10. Remove generator. Refer to [CHG-20, "Removal and Installation"](#).
11. Set the No.1 cylinder at TDC on the compression stroke using the following procedure:
 - a. Rotate the crankshaft pulley clockwise and align the mating mark (B) to the timing indicator (A) on the front cover.
NOTE:
Do not use the white paint marks (C).

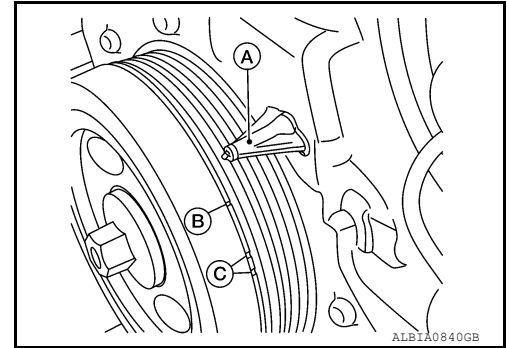

- b. At the same time, make sure that the camshaft sprocket mating marks (B) line up with the painted marks on the timing chain (A).
 - If not lined up, rotate the crankshaft pulley one more turn to line up the mating marks to the positions as shown.**NOTE:**
Shown with front cover removed for illustration purposes only.

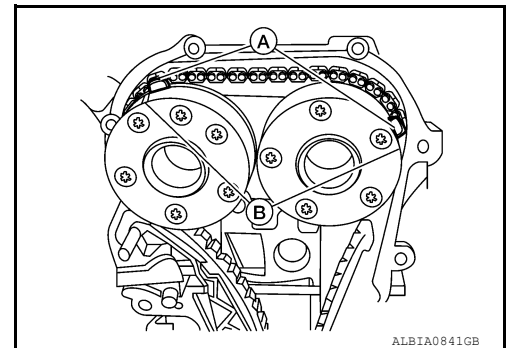

12. Remove crankshaft pulley (1) using the following procedure:
 - a. Hold the crankshaft pulley (1) using suitable tool (A), then loosen and remove the crankshaft pulley bolt.

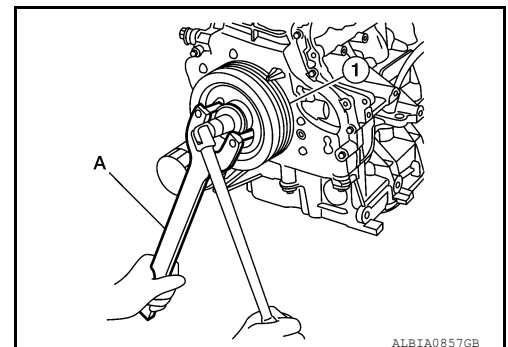

TIMING CHAIN

< REMOVAL AND INSTALLATION >

- b. Attach suitable tool (A) in the M 6 (0.24 in diameter) thread hole on crankshaft pulley (1), and remove crankshaft pulley.

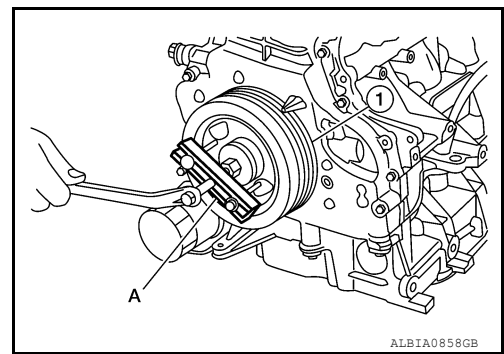

13. Remove the intake valve timing control cover. Refer to [EM-80. "Valve Timing Control Cover"](#).
14. Remove the front cover using the following procedure:
a. Loosen the bolts in reverse order as shown, and remove them.

(A) : Dowel pin

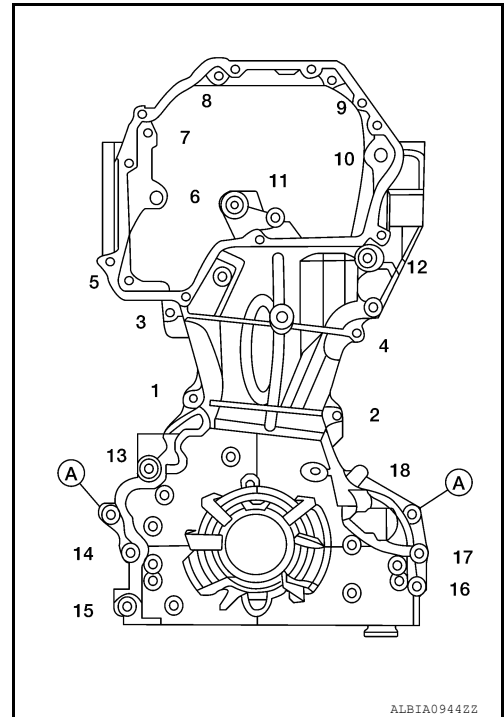

- b. Cut liquid gasket using Tool (A).

Tool number : KV10111100 (J-37228)

CAUTION:

Be careful not to damage the front cover.

- c. Remove the front cover.
d. Remove front oil seal using suitable tool, (if necessary).

CAUTION:

Be careful not to damage the front cover.

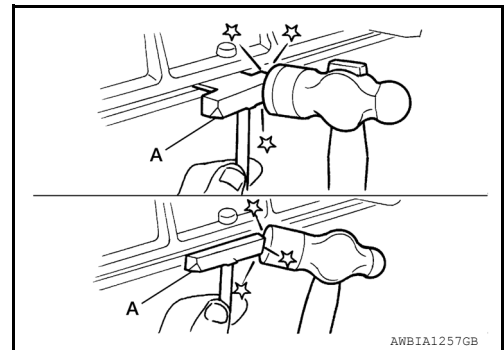

15. Remove chain tensioner (1) and timing chain using the following procedure:
a. Pull the lever (B) down and release the plunger stopper tab (C).

TIMING CHAIN

< REMOVAL AND INSTALLATION >

- Plunger stopper tab (C) can be pushed up to release (coaxial structure with lever (B)).

- b. Insert the stopper pin (A) into the tensioner body hole to hold the lever (B) and keep tab released.

NOTE:

Allen wrench [2.5 mm (0.098)] is used for a stopper pin as an example.

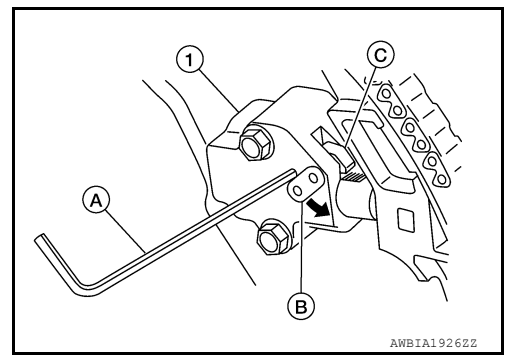

- c. Insert plunger (C) into tensioner body by pressing timing chain slack guide (1).
- d. Keep timing chain slack (1) guide pressed and hold it by pushing the stopper pin (B) through the lever hole and body hole.
- e. Remove the chain tensioner bolts (A) and chain tensioner.

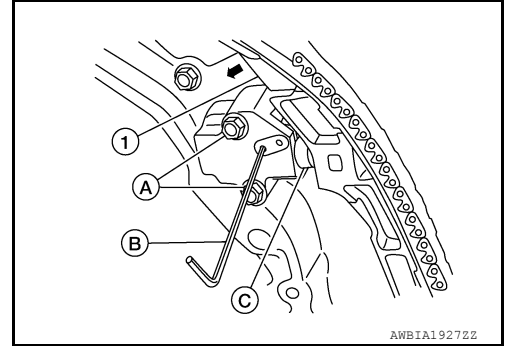

- f. Remove the timing chain.

CAUTION:

Do not rotate the crankshaft or camshafts while the timing chain is removed. It can cause damage to the valves and pistons.

16. Remove the camshaft sprockets using the following procedure:

- a. Secure hexagonal part of the camshaft with a wrench and loosen the camshaft sprocket bolt.
- b. Remove the camshaft sprocket bolt and camshaft sprockets for both camshafts.

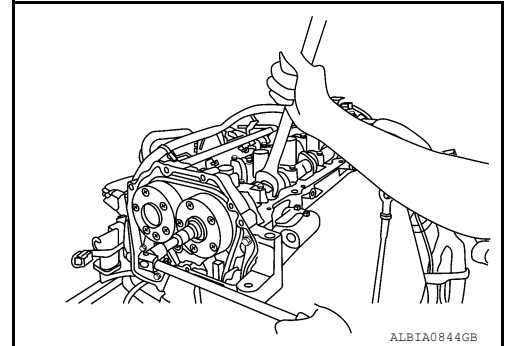

17. Remove the timing chain slack guide, timing chain tension guide, and oil pump drive spacer.

TIMING CHAIN

< REMOVAL AND INSTALLATION >

18. Press stopper tab (A) in the direction shown to push the timing chain slack guide (B) toward timing chain tensioner (1) for the balancer unit.
 - The timing chain slack guide (B) is released by pressing the stopper tab (A). As a result, the timing chain slack guide (B) can be moved.
19. Insert stopper pin (D) into tensioner body hole (C) to secure timing chain slack guide (B).

NOTE:
Use a hard metal pin with a diameter of approximately 1.2 mm (0.047 in) as a stopper pin.
20. Remove timing chain tensioner (1) for balancer unit.
21. Secure width across flats of the balancer unit LH side shaft using a suitable tool. Loosen the balancer unit sprocket bolt.
22. Remove balancer unit timing chain, balancer unit sprocket and crankshaft sprocket.

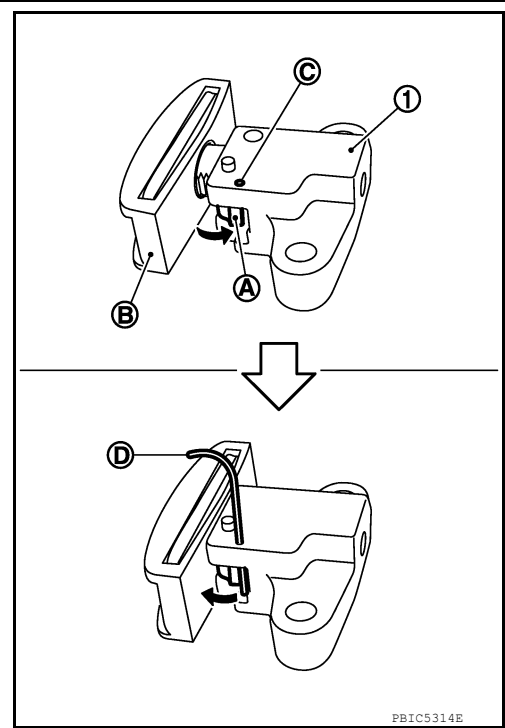

PBIC5314E

23. Loosen bolts in the reverse order shown, and remove balancer unit.

CAUTION:

- Do not disassemble balancer unit.

← : Engine front

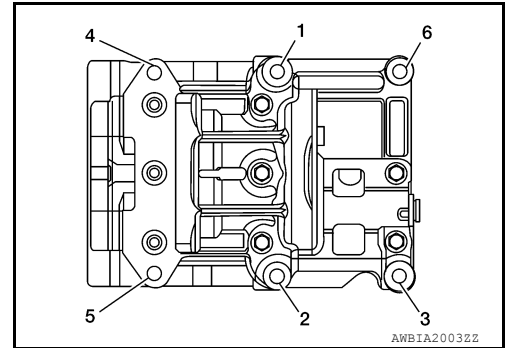

AWBIA2003ZZ

INSPECTION AFTER REMOVAL

Oil Filter

- Check that there is no foreign material on the oil filter (1) and check for clogging.
- Check the oil filter for damage.
- If there is damage, replace the oil filter.

CAUTION:

Do not reuse oil filter.

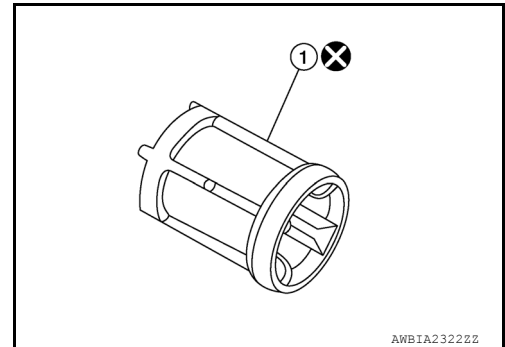

AWBIA2322ZZ

Timing Chain

A
EM
C
D
E
F
G
H
I
J
K
L
M
N
O
P

TIMING CHAIN

< REMOVAL AND INSTALLATION >

Check the timing chain for cracks (A) or excessive wear (B). If a defect is found, replace the timing chain.

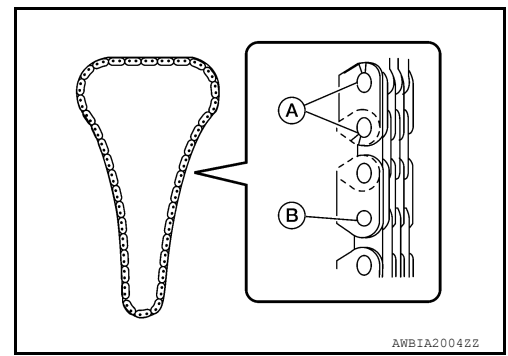

Balancer Unit Bolt Outer Diameter

- Measure outer diameters (d1, d2) at the two positions as shown.
- Measure d2 within the range (A).
- If the value difference (d1 - d2) exceeds the limit, replace the balancer unit bolt with a new one.

Limit : 0.15 mm (0.0059 in) or more

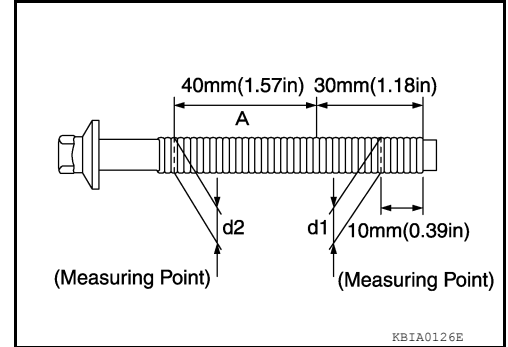

INSTALLATION

1. Make sure the crankshaft key points straight up.
2. Install the balancer unit and tighten the bolts in the numerical order as shown:

← : Engine front

CAUTION:

- When reusing a bolt, check its outer diameter before installation. Follow the Balancer Unit Bolt Outer Diameter procedure.
- Apply new engine oil to threads and seating surfaces of bolts.

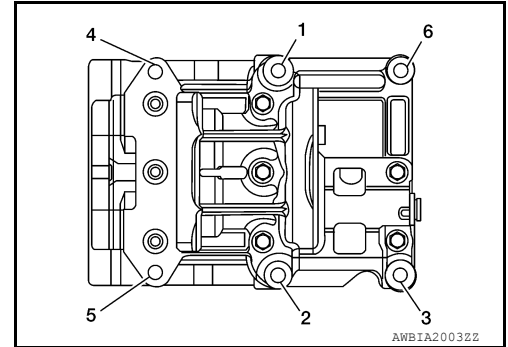

- Check tightening angle with an angle wrench (A) or a protractor. Do not make judgment by visual check alone.

Tool number : KV10112100 (BT-8653-A)

Step 1	Bolts 1-5	: 42 N·m (4.3 kg-m, 31 ft-lb)
	Bolt 6	: 36 N·m (3.7 kg-m, 27 ft-lb)
Step 2	Bolts 1-5	: 120° + 5°
	Bolt 6	: 90° + 5°
Step 3	Loosen in reverse order	: 0 N·m (0 kg-m, 0 ft-lb)
Step 4	Bolts 1-5	: 42 N·m (4.3 kg-m, 31 ft-lb)
	Bolt 6	: 36 N·m (3.7 kg-m, 27 ft-lb)
Step 5	Bolts 1-5	: 120° + 5°
	Bolt 6	: 90° + 5°

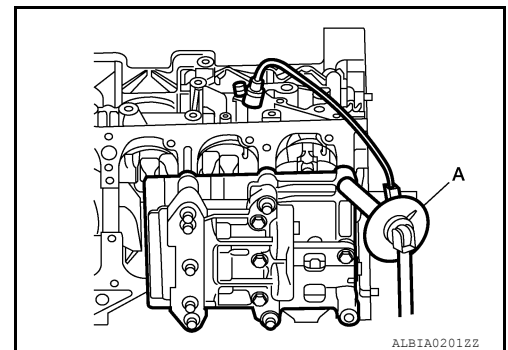

TIMING CHAIN

< REMOVAL AND INSTALLATION >

3. Install the crankshaft sprocket (1) and timing chain (2) for the balancer unit.
 - Make sure that the crankshaft sprocket (1) is positioned with mating marks (A) on the block and sprocket meeting at the top.
 - Install it by lining up mating marks on each sprocket (A), (C) and timing chain (B), (D).
 - (B): Pink link
 - (D): Yellow link

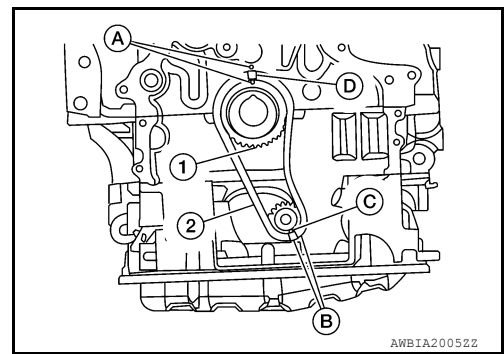

4. Install timing chain tensioner for balancer unit (1).
 - Compress the plunger, insert a stopper pin (A), and then install the tensioner for the balancer unit.
 - Do not pull out (←) the stopper pin until after installing the timing chain tensioner for balancer unit.
 - Check matching mark position of balancer unit drive chain and each sprocket again.

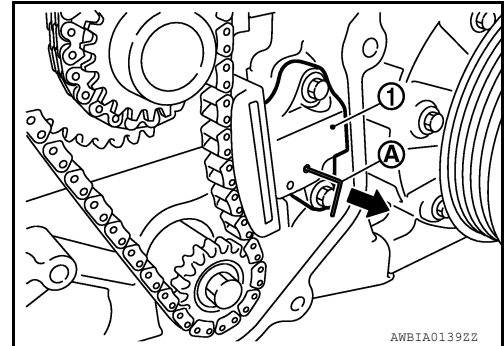

5. Install camshaft sprockets.
 - Install them by lining up the mating marks on each camshaft sprocket (B) with the ones painted on the timing chain (A) during removal.
 - Before installation of chain tensioner, it is possible to re-match the marks on timing chain with the ones on each sprocket.

CAUTION:

- **Aligned mating marks could slip. Therefore, after matching them, hold the timing chain in place by hand.**
- **Before and after installing chain tensioner, check again to make sure that mating marks have not slipped.**

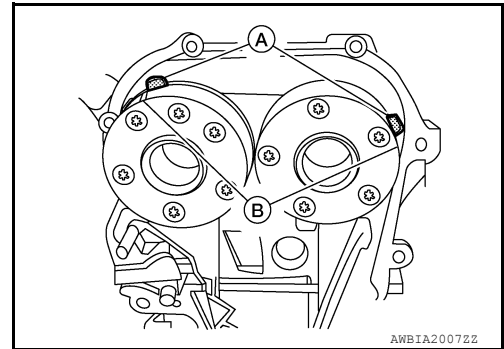

6. Install chain tensioner using the following procedure:
 - a. Install stopper pin (A) into the chain tensioner (1).
 - b. Install the chain tensioner and pull the stopper pin out.

CAUTION:

- **After installation, pull the stopper pin out, and make sure that the tensioner is fully released.**

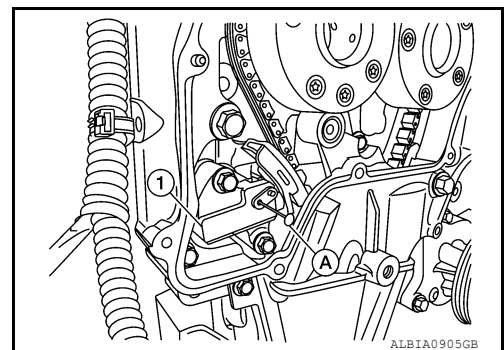

A
EM
C
D
E
F
G
H
I
J
K
L
M
N
O
P

TIMING CHAIN

< REMOVAL AND INSTALLATION >

7. Install timing chain (1) and related parts.
 - Install by lining up mating marks on each sprocket and timing chain as shown.
 - Before and after installing chain tensioner (3), check to make sure the mating marks have not slipped.
 - After installing timing chain tensioner (3), remove the stopper pin, and make sure that the tensioner moves freely.

CAUTION:

- For the following note, after the mating marks are aligned, keep them aligned by holding them by hand.
- To avoid skipped teeth, do not move crankshaft and camshaft until front cover is installed.

NOTE:

- Before installing chain tensioner (3) it is possible to slip the chain on the sprocket to align the chain timing mark with the sprocket timing mark.
- There may be two color variations of the link marks (link colors) on the timing chain.
- There are 26 links between the pink mating marks on the timing chain; and 64 links between the camshaft sprocket pink link and the crankshaft sprocket yellow link, on the timing chain side without the tensioner.

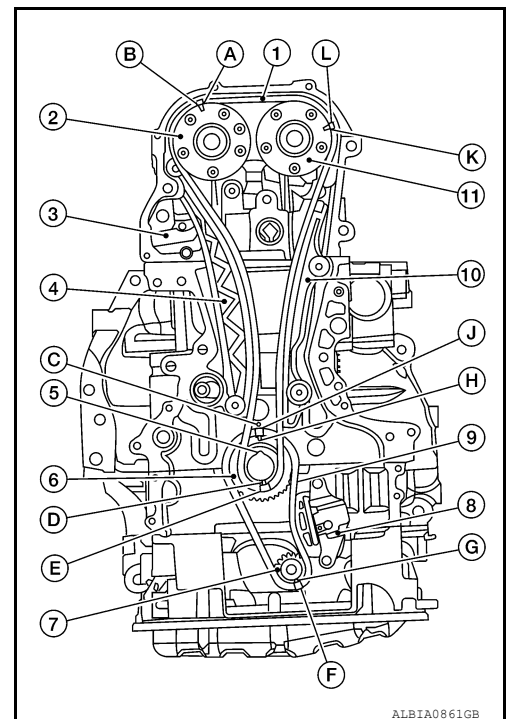

- (2) : Camshaft sprocket (INT)
- (4) : Timing chain slack guide
- (5) : Crankshaft key
- (6) : Crankshaft sprocket
- (7) : Balancer unit sprocket
- (8) : Balancer unit chain tensioner
- (9) : Balancer unit timing chain
- (10) : Timing chain tension guide
- (11) : Camshaft sprocket (EXH)
- (A) : Mating mark (Outer groove)
- (B) : Pink link
- (C) : Mating mark (lug)
- (D) : Mating mark (stamp)
- (E) : Yellow link
- (F) : Pink link
- (G) : Mating mark (stamp)
- (H) : Mating mark (stamp)
- (J) : Yellow link
- (K) : Mating mark (Outer groove)
- (L) : Pink link

8. Install new front oil seal to front cover. Refer to [EM-83. "FRONT OIL SEAL : Removal and Installation"](#).
9. Install front cover with the following procedure:
 - a. Install O-rings to cylinder head and cylinder block.

CAUTION:

Do not reuse O-rings.

TIMING CHAIN

< REMOVAL AND INSTALLATION >

- b. Apply a continuous bead of liquid gasket to front cover as shown.

- (a) : 35.7 mm (1.406 in)
- (b) : 6.0 – 7.0 mm (0.236 – 0.276 in)
- (c) : 3.4 – 4.4 mm (0.134 – 0.173 in)
- (d) : 179.6 mm (7.07 in)
- (e) : 35.5 mm (1.398 in)
- (f) : 31.3 mm (1.232 in)
- (G) : Dowel pin hole

Use Genuine RTV Silicone Sealant or equivalent. Refer to [GI-22, "Recommended Chemical Products and Sealants"](#).

CAUTION:

- Be sure sealant surfaces are free from grease, dirt, water, and engine oil.
- Be sure to apply sealant without breaks or overlap.
- Installation should be done within 5 minutes after application of liquid gasket.
- Do not fill the engine with engine oil for at least 30 minutes after the components are installed to allow the liquid gasket to cure.

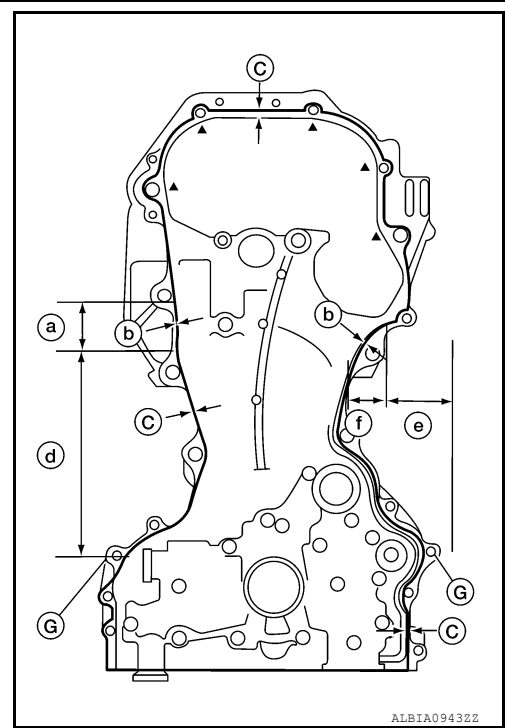

- c. Make sure the mating marks on the timing chain and each sprocket are still aligned. Then install the front cover.

CAUTION:

Do not damage the front oil seal during installation.

- d. Tighten front cover bolts in the numerical order shown.
 e. After all bolts are tightened, retighten them to the specified torque.

Front cover bolts

- Bolts 6, 10, 12** : 49 N·m (5.0 kg-m, 36 ft-lb)
- Bolts (all remaining)** : 12.8 N·m (1.3 kg-m, 9 ft-lb)
- (A)** : Dowel pin

CAUTION:

Wipe off excess sealant leaking at the surface for installing the oil pan.

10. Install the chain guide between the camshaft sprockets.

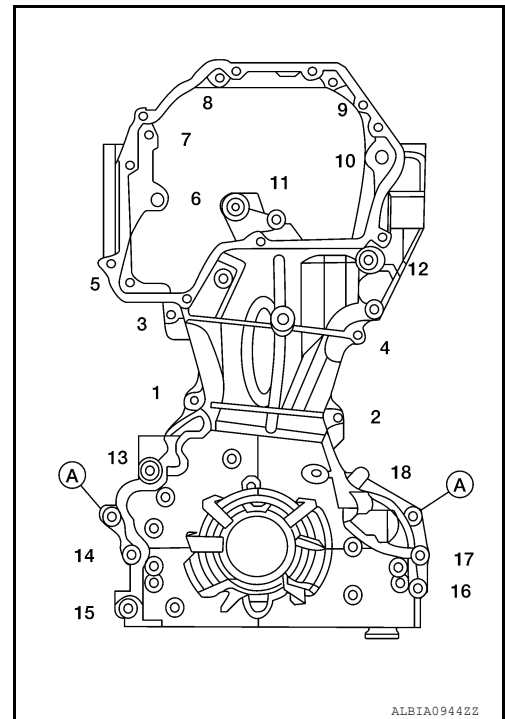

11. Install valve timing control cover. Refer to [EM-80, "Valve Timing Control Cover"](#).

12. Insert crankshaft pulley by aligning with crankshaft key.

- Tap its center with a plastic hammer to insert.

CAUTION:

- Do not hit belt mounting section with hammer to avoid breaking belt guide.
- Be sure not to damage front oil seal while installing crankshaft pulley.

TIMING CHAIN

< REMOVAL AND INSTALLATION >

13. Install crankshaft pulley bolt (1) and tighten to specification.

CAUTION:

- Apply anti-corrosive engine oil to threads of crankshaft pulley bolt (1) and bolt bearing surface prior to installation.
- Secure crankshaft pulley (2) with suitable tool to tighten the bolt.

Step 1 : Crankshaft bolt (1) : 42.1 N·m (4.3 kg-m, 31 ft-lb)

Step 2 : Crankshaft bolt (1) : 60° + 6°

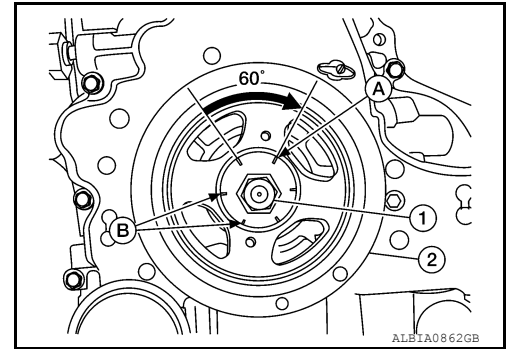

14. Apply a paint mark (A) on the front cover, mating with any one of six easy to recognize stamp marks on bolt flange (B).

15. Installation of the remaining components is in the reverse order of removal.

CYLINDER HEAD

< REMOVAL AND INSTALLATION >

CYLINDER HEAD

Exploded View

INFOID:000000011279962

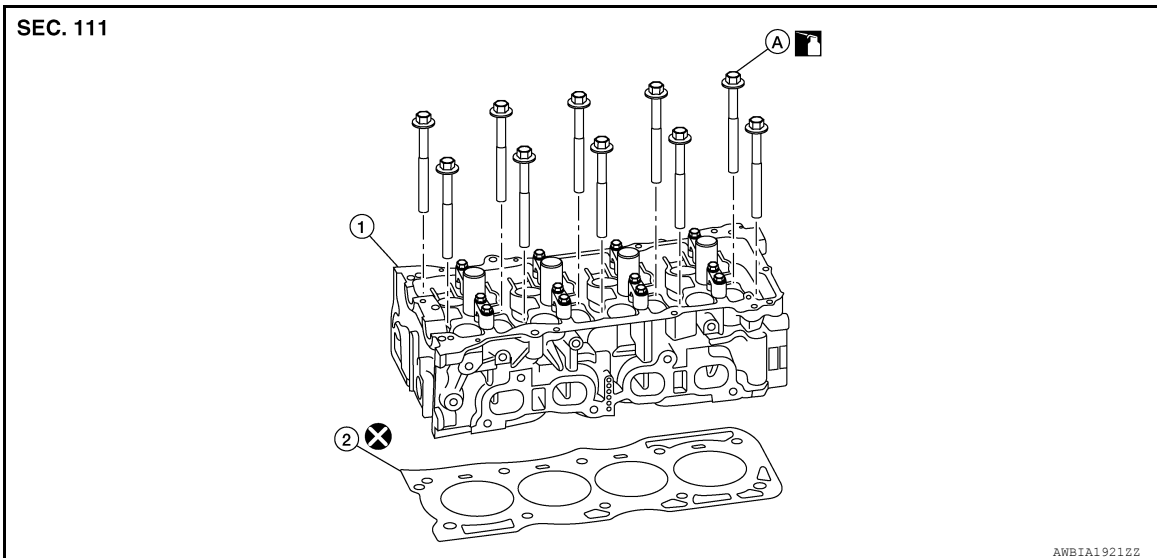

1. Cylinder head

2. Cylinder head gasket

A. Refer to INSTALLATION

Removal and Installation

INFOID:000000011279963

REMOVAL

1. Remove the timing chain. Refer to [EM-50, "Removal and Installation"](#).
2. Remove the camshafts. Refer to [EM-69, "Removal and Installation"](#).
3. Remove spark plugs. Refer to [EM-19, "Removal and Installation"](#).
4. Remove the intake manifold. Refer to [EM-29, "Removal and Installation"](#).
5. Remove the exhaust manifold and three way catalyst. Refer to [EM-32, "Removal and Installation"](#).
6. Loosen the cylinder head bolts in the reverse order shown, using power tool.

← : Engine front

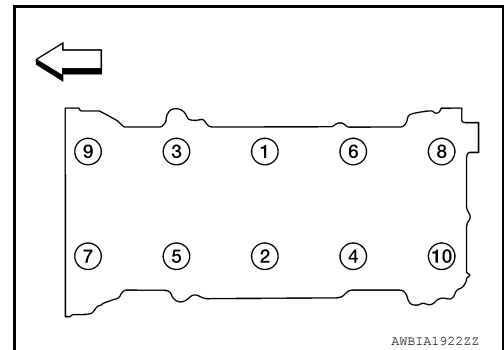

7. Remove cylinder head.
8. Remove cylinder head gasket.

INSPECTION AFTER REMOVAL

Outer Diameter of Cylinder Head Bolts

CYLINDER HEAD

< REMOVAL AND INSTALLATION >

- Replace the cylinder head bolts with new ones if the size difference between d1 and d2 exceeds the limit.

Limit (d1 - d2) : 0.23 mm (0.0091 in) or more

- If reduction of outer diameter appears in a position other than d2, use it as d2 point.

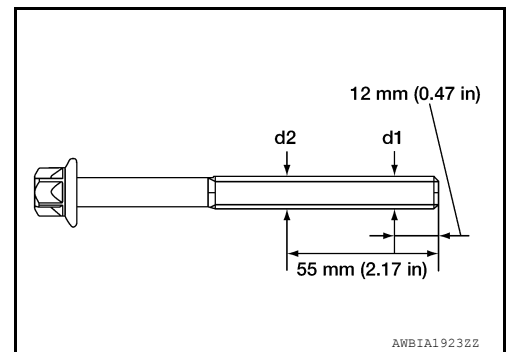

INSTALLATION

1. Clean surfaces of cylinder head and cylinder block.
2. Install a new cylinder head gasket.
 - CAUTION:**
Do not reuse cylinder head gasket.
3. Install the cylinder head.
4. Follow the steps below to tighten the cylinder head bolts in the numerical order as shown.
 - Clean threads and seating surfaces of bolts.
 - Apply new engine oil to the threads and the seating surfaces of bolts.

CAUTION:

- If cylinder head bolts are re-used, check their outer diameters before installation. Follow the Outer Diameter of Cylinder Head Bolts measurement procedure.
- Check and confirm the tightening angle by using angle wrench or protractor. Do not judge angle by visual inspection.

Tool number (A) : KV10112100 (BT-8653-A)

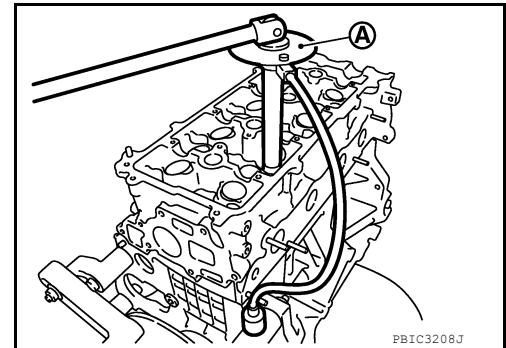

- Step a : 50 N·m (5.1 kg-m, 37 ft-lb) in order**
- Step b : 60° clockwise in order**
- Step c : Loosen to 0 N·m in order**
- Step d : 39.2 N·m (4.0 kg-m, 29 ft-lb) in order**
- Step e : 75° clockwise in order**
- Step f : 75° clockwise in order**

← : Engine front

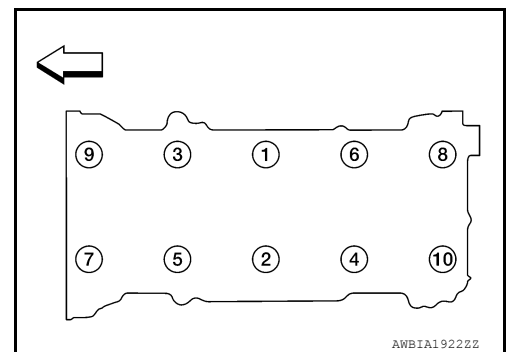

5. Installation of the remaining components is in the reverse order of removal.

CYLINDER HEAD

< REMOVAL AND INSTALLATION >

Disassembly and Assembly

INFOID:000000011279964

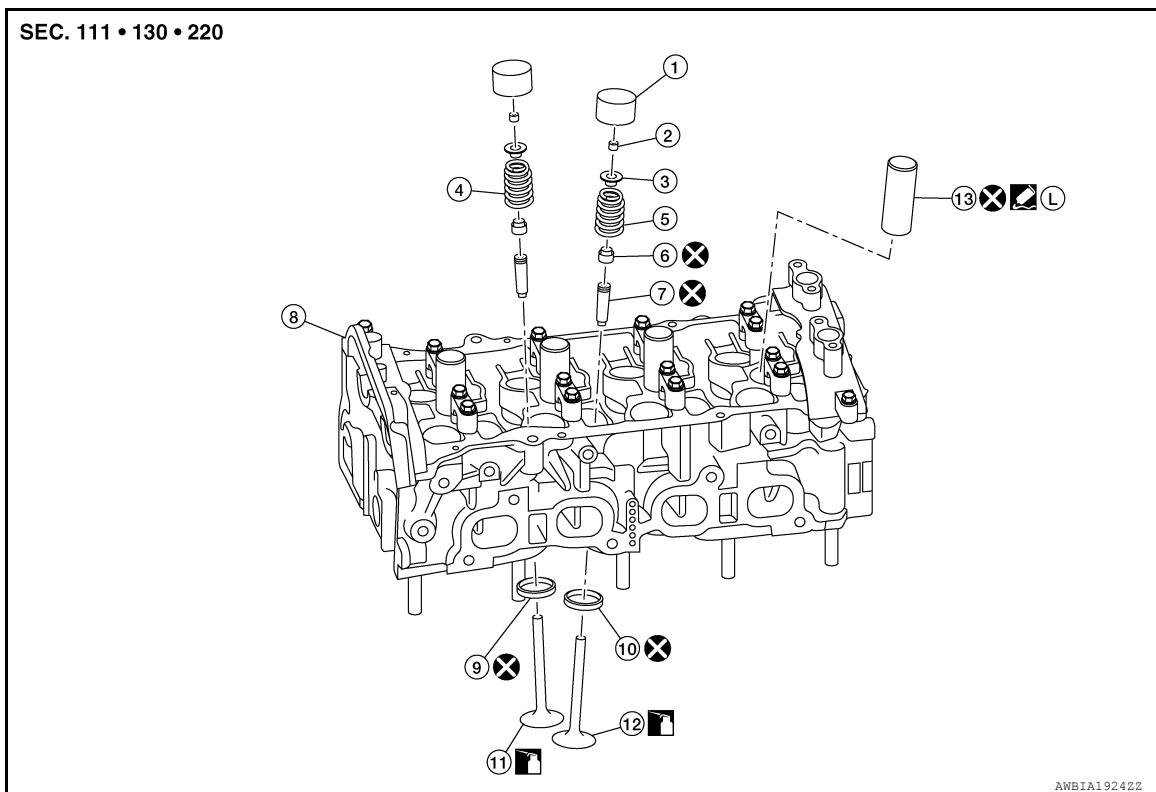

- | | | |
|-----------------------|---------------------------------|--------------------------|
| 1. Valve lifter | 2. Valve collet | 3. Valve spring retainer |
| 4. Valve spring (INT) | 5. Valve spring (EXH) | 6. Valve oil seal |
| 7. Valve guide | 8. Cylinder head | 9. Valve seat (INT) |
| 10. Valve seat (EXH) | 11. Valve (INT) | 12. Valve (EXH) |
| 13. Spark plug tube | L. Apply thread locking sealant | |

CAUTION:

- When installing camshafts, chain tensioners, oil seals or other sliding parts, lubricate contacting surfaces with new engine oil.
- Apply new engine oil to threads and seat surfaces when installing the cylinder head, camshaft sprocket, crankshaft pulley and camshaft bracket.
- Attach tags to valve lifters so all parts are assembled in their original position.

CAUTION:

Read PRECAUTION carefully.

The exhaust valve contains metallic sodium. Therefore, extreme caution must be taken when handling and disposing of the exhaust valve. Refer to [EM-4, "Special Cautions to Ensure the Safe Disposal of Sodium-filled Exhaust Valves"](#).

DISASSEMBLY

1. Remove the valve lifter.

NOTE:

Confirm installation point to return valve lifter to original location during assembly.

CYLINDER HEAD

< REMOVAL AND INSTALLATION >

2. Remove valve collet, valve spring retainer, and valve spring using suitable tool (A). Remove valve collet with magnetic hand.

CAUTION:

- Be careful not to damage valve lifter holes.

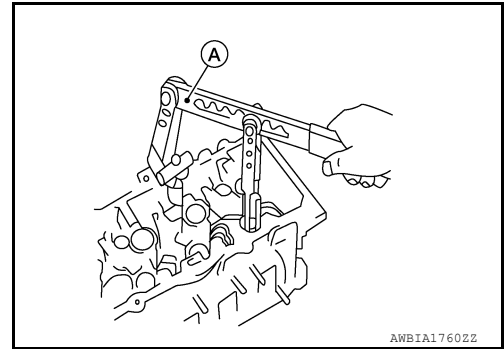

- Install suitable tool (A) in the center of valve spring retainer (1) to install it.

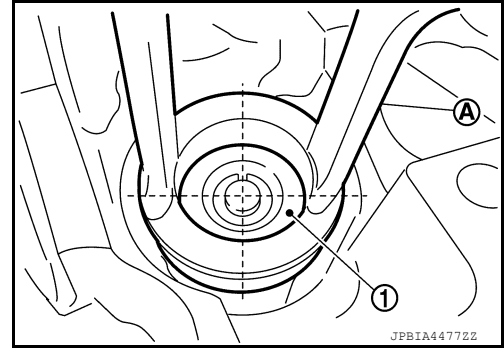

3. Remove valve spring retainer and valve spring (with valve spring seat).

CAUTION:

Do not remove valve spring seat from valve spring.

4. Push valve stem to combustion chamber side, and remove valve.
 - Inspect valve guide clearance before removal. Refer to [EM-66, "Inspection After Disassembly"](#).
 - Confirm installation point to return valve to original location during assembly.
5. Remove valve oil seal using suitable tool (A).

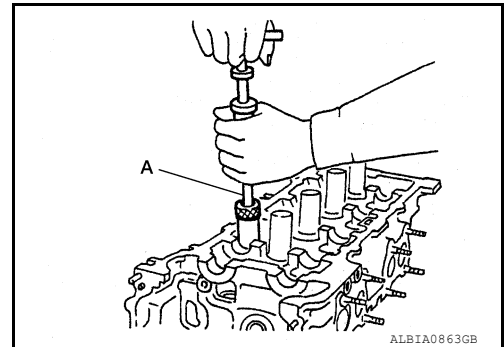

6. Remove valve seat, if necessary.
 - Bore out old seat until it collapses. Boring should not continue beyond the bottom face of the seat recess in cylinder head. Set the machine depth stop to ensure this. Refer to [EM-122, "Cylinder Head"](#).

CAUTION:

Do not bore excessively to prevent damage to cylinder head.

7. Remove valve guide, if necessary.

CYLINDER HEAD

< REMOVAL AND INSTALLATION >

- a. To remove valve guide, heat cylinder head to 110°C to 130°C (230°F to 266°F) by soaking in heated engine oil (A).

WARNING:

Cylinder head contains heat. When working, wear protective equipment to avoid getting burned.

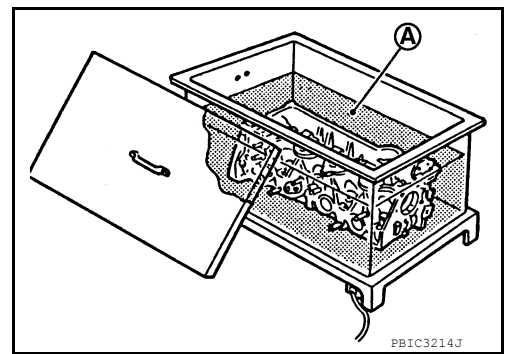

- b. Drive out valve guide using suitable tool.

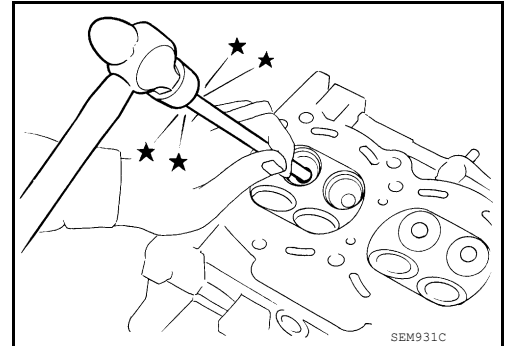

8. Remove spark plugs. Refer to [EM-19. "Removal and Installation"](#)

9. Remove spark plug tubes, if necessary, using suitable tool.

CAUTION:

- Be careful not to damage cylinder head.
- Do not remove spark plug tube if not necessary. Once removed, the spark plug tube cannot be reused because of deformation during removal.

ASSEMBLY

1. Install valve guide, if removed.

- a. Ream cylinder head valve guide hole using suitable tool (A). Refer to [EM-122. "Cylinder Head"](#).

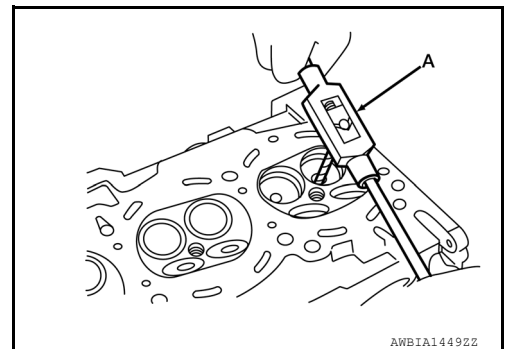

- b. Heat cylinder head to 110°C to 130°C (230°F to 266°F) by soaking in heated engine oil (A).

WARNING:

Cylinder head contains heat. When working, wear protective equipment to avoid getting burned.

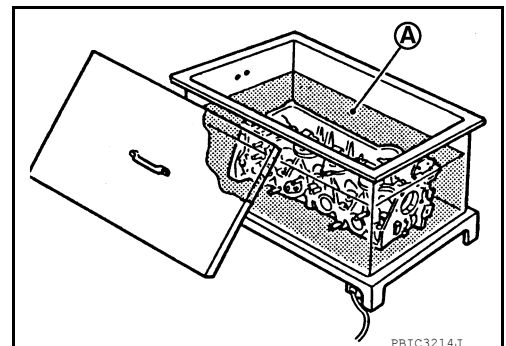

CYLINDER HEAD

< REMOVAL AND INSTALLATION >

- c. Press valve guide (1) into cylinder head (2) from camshaft side to dimension as shown.

Projection (H) : Refer to [EM-122, "Cylinder Head"](#)

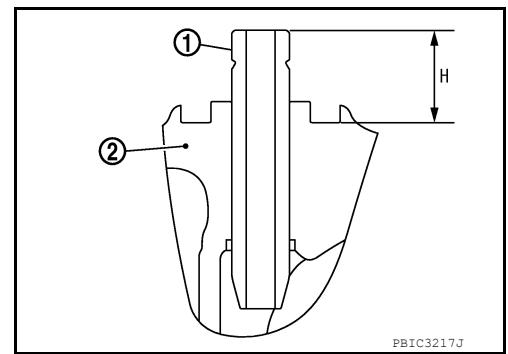

- d. Apply reamer finish to valve guide using suitable tool (A).

Standard : Refer to [EM-122, "Cylinder Head"](#)

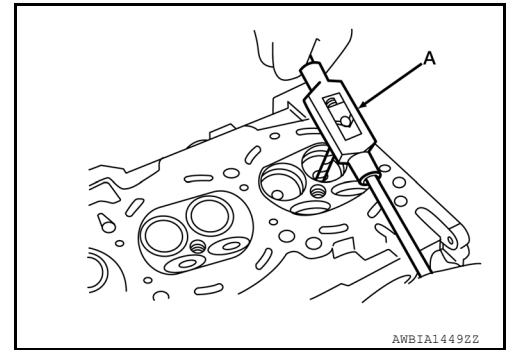

2. Install valve seat, if removed.

- a. Ream cylinder head (1) recess diameter for service valve seat (2).

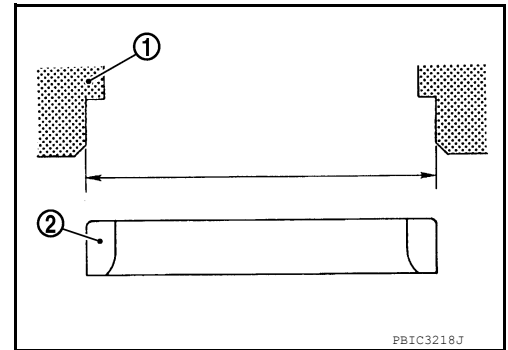

- b. Heat cylinder head to 110°C to 130°C (230°F to 266°F) by soaking in heated engine oil (A).

WARNING:

Cylinder head contains heat. When working, wear protective equipment to avoid getting burned.

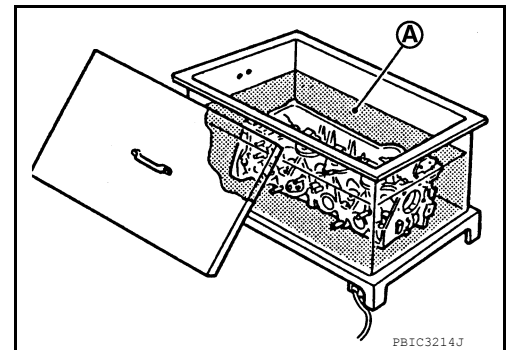

- c. Allow valve seats to cool with dry ice. Press-fit valve seat into cylinder head.

CAUTION:

Do not touch cold valve seats directly.

CYLINDER HEAD

< REMOVAL AND INSTALLATION >

- d. Finish valve seat to the specified dimension using suitable tool. Refer to [EM-122, "Cylinder Head"](#).

CAUTION:

When using valve seat cutter, firmly grip the cutter handle with both hands. Then, press on the contacting surface all around the circumference to cut in a single drive. Improper pressure on the cutter or cutting many different times may result in stage valve seat.

- e. Using compound, grind to adjust valve.

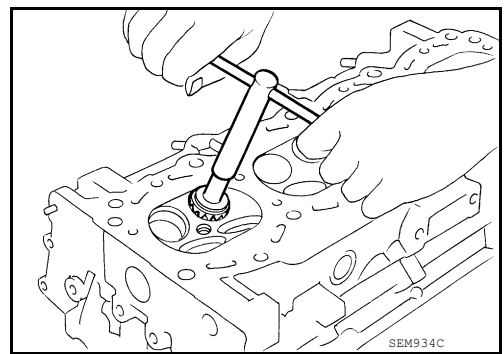

- f. Check again for normal contact. Refer to [EM-122, "Cylinder Head"](#).

(A) : OK

(B) : NG

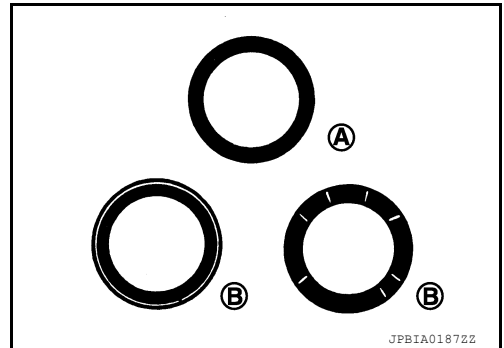

3. Apply new engine oil to new valve oil seal joint surface and seal lip.
4. Install new valve oil seal using suitable tool (A) as shown.

NOTE:

Dimension is height measured before installing valve spring (with valve spring seat).

Projection (H) : Refer to [EM-122, "Cylinder Head"](#)

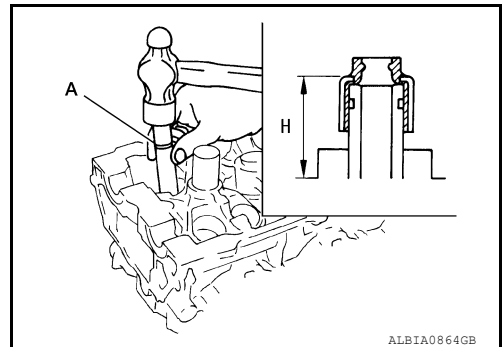

5. Install valve.
• Install larger diameter to intake side.
6. Install valve spring with valve spring seat (1).
• Install valve spring so that the identification color faces upward (A).
• Install smaller pitch to cylinder head side (B).
• Confirm the identification color of the valve spring.

Intake : White

Exhaust : Light blue

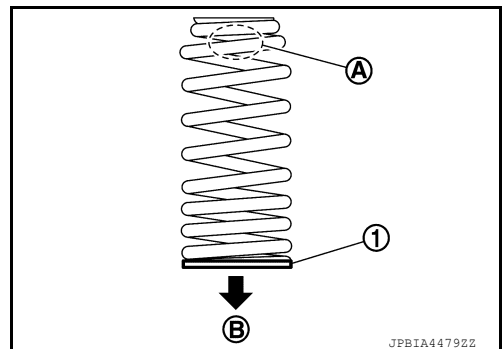

7. Install valve spring retainer.
8. Install valve collet.

CYLINDER HEAD

< REMOVAL AND INSTALLATION >

- Compress valve spring using suitable tool (A). Install valve collet with a magnet hand.
- CAUTION:**
When working do not damage valve lifter holes.
- Tap valve stem edge lightly with a plastic hammer after installation to check its installed condition.

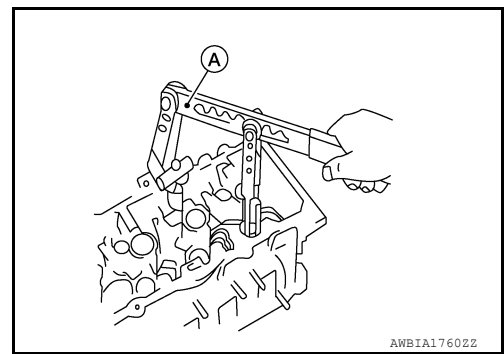

9. Install valve lifter.
10. Install spark plug. Refer to [EM-19, "Removal and Installation"](#)

Inspection After Disassembly

INFOID:000000011279965

CYLINDER HEAD DISTORTION

1. Wipe off engine oil and remove water scale deposits, old gasket, old sealer, and carbon using a suitable tool.
- CAUTION:**
Use care not to allow gasket debris to enter passages for engine oil or engine coolant.
2. At each of several locations on bottom surface of cylinder head, measure distortion in six directions using suitable tools (A, B).

Limit : Refer to [EM-122, "Cylinder Head"](#)

- If measurements exceed the limit, replace cylinder head.

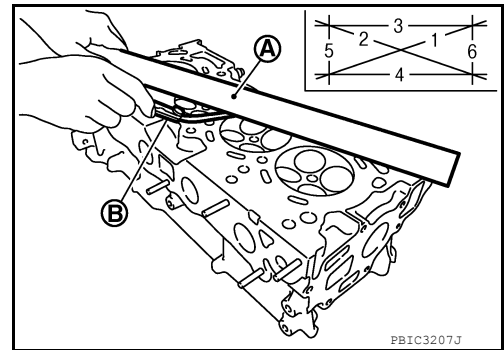

VALVE DIMENSIONS

1. Check dimensions of each valve. Refer to [EM-122, "Cylinder Head"](#).
2. If dimensions are out of the standard, replace valve and check valve seat contact.

VALVE SEAT CONTACT

NOTE:

After confirming that the dimensions of valve guides and valves are within specifications, perform this procedure:

1. Apply prussian blue (or white lead) onto contacting surface of valve seat to check the condition of the valve contact on the seat surface.
2. Ensure that the contact area band is continuous all around the circumference.

(A) : OK

(B) : NG

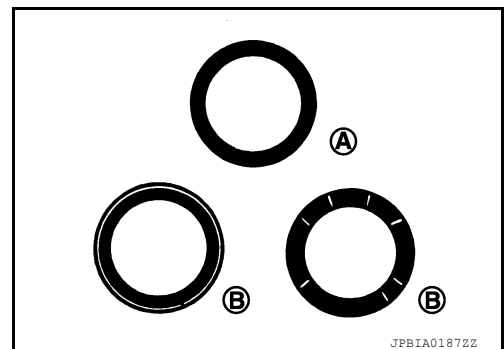

3. If the contact area is not continuous, grind to adjust valve fitting and check again. If the contacting surface still has NG conditions even after the re-check, replace the valve seat.

VALVE GUIDE CLEARANCE

CYLINDER HEAD

< REMOVAL AND INSTALLATION >

1. Measure diameter of valve stem using suitable tool (A) as shown.

Standard : Refer to [EM-122, "Cylinder Head"](#)

2. Measure inner diameter of valve guide using suitable tool.

Standard : Refer to [EM-122, "Cylinder Head"](#)

3. Valve guide clearance = (Valve guide inner diameter) - (Valve stem diameter)

Standard and Limit : Refer to [EM-122, "Cylinder Head"](#)

4. If the calculated value exceeds the limit, replace valve and/or valve guide. When valve guide must be replaced. Refer to [EM-61, "Disassembly and Assembly"](#)

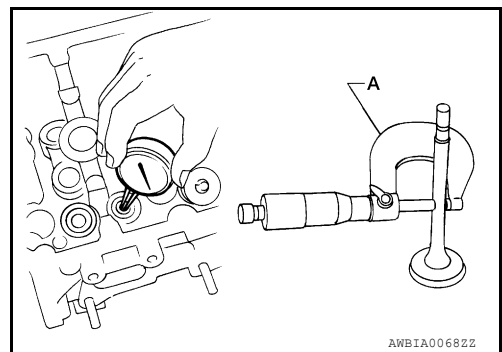

VALVE SPRING SQUARENESS

CAUTION:

Do not remove the valve spring seat from the valve spring

1. Set a try square (A) along the side of valve spring and rotate spring. Measure the maximum clearance between the top of spring and try square.

(B) : Contact

Limit : Refer to [EM-122, "Cylinder Head"](#).

2. If the valve spring exceeds the limit, replace the valve spring with the valve spring seat.

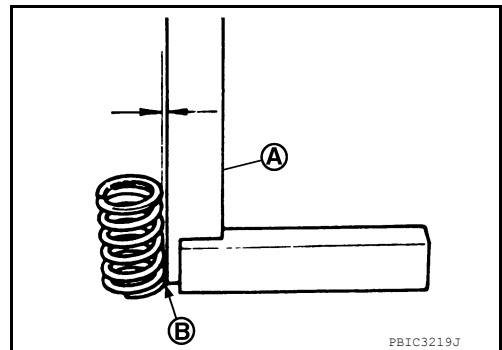

VALVE SPRING PRESSURE LOAD

CAUTION:

Do not remove the valve spring seat.

1. Check valve spring pressure with valve spring seat installed at the specified spring height.

Standard : Refer to [EM-122, "Cylinder Head"](#).

2. If the installation load or load with valve open is out of the standard, replace valve spring with valve spring seat.

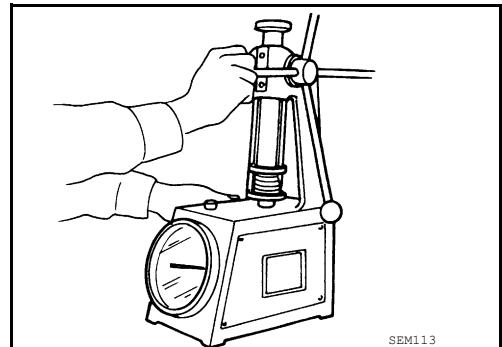

INSPECTION AFTER INSTALLATION

Inspection for Leaks

1. Before starting engine, check oil/fluid levels including engine coolant and engine oil. If less than required quantity, fill to the specified level. Refer to [LU-8, "Refilling"](#).
2. Use the following steps to check for fuel leaks.
 - a. Turn ignition switch "ON" (with engine stopped).
 - b. With fuel pressure applied to fuel piping, check for fuel leaks at connection points.

CYLINDER HEAD

< REMOVAL AND INSTALLATION >

- c. Start engine.
- d. With engine speed increased, check again for fuel leaks at connection points.
3. Run engine to check for unusual noise and vibration.

NOTE:

If hydraulic pressure inside timing chain tensioner drops after removal and installation, slack in the guide may generate a pounding noise during and just after engine start. However, this is normal. Noise will stop after hydraulic pressure rises.

4. Warm up engine thoroughly to check there are no fuel leaks, exhaust gas leaks, or any oil/fluid leaks including engine oil and engine coolant.
5. Bleed air from lines and hoses of applicable lines, such as in cooling system.
6. After cooling down engine, again check oil/fluid levels including engine oil and engine coolant. Refill to the specified level, if necessary.

Summary of the inspection items:

Items		Before starting engine	Engine running	After engine stopped
Engine coolant		Level	Leakage	Level
Engine oil		Level	Leakage	Level
Transmission / transaxle fluid	AT & CVT Models	Leakage	Level / Leakage	Leakage
	MT Models	Level / Leakage	Leakage	Level / Leakage
Other oils and fluids*		Level	Leakage	Level
Fuel		Leakage	Leakage	Leakage
Exhaust gases		—	Leakage	—

*: Power steering fluid, brake fluid, etc.

CAMSHAFT

< REMOVAL AND INSTALLATION >

CAMSHAFT

Exploded View

INFOID:0000000011366284

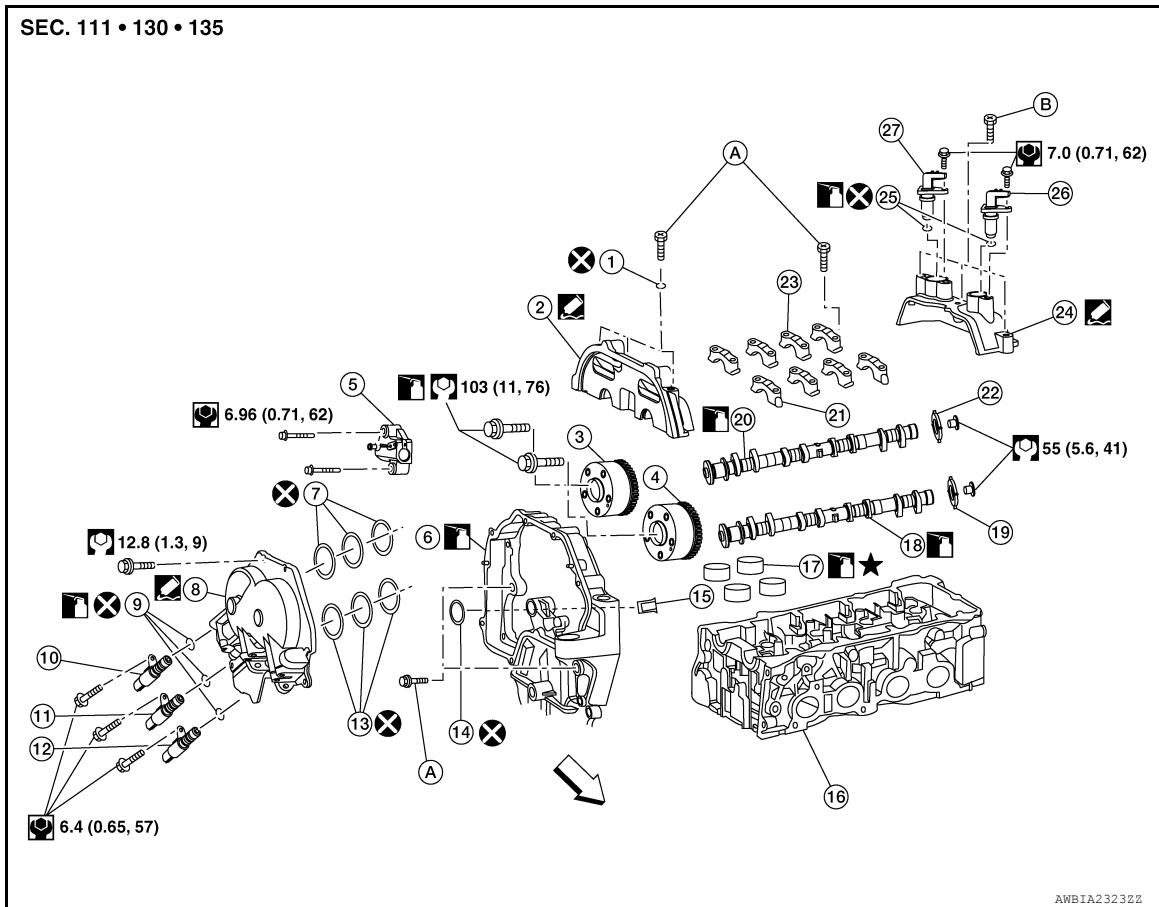

- | | | |
|--|--|---|
| 1. Washer | 2. Camshaft bracket (No.1) | 3. Camshaft sprocket (INT) |
| 4. Camshaft sprocket (EXH) | 5. Chain tensioner | 6. Front cover (partial view) |
| 7. Valve timing control cover O-rings (INT) | 8. Valve timing control cover | 9. Valve timing control solenoid valve O-rings |
| 10. Intake valve timing intermediate lock control solenoid valve | 11. Intake valve timing control solenoid valve | 12. Exhaust valve timing control solenoid valve |
| 13. Valve timing control cover O-rings (EXH) | 14. O-ring | 15. Oil filter |
| 16. Cylinder head | 17. Valve lifters | 18. Camshaft (EXH) |
| 19. Signal plate (EXH) | 20. Camshaft (INT) | 21. Camshaft brackets (EXH) |
| 22. Signal plate (INT) | 23. Camshaft brackets (INT) | 24. Camshaft position sensor bracket |
| 25. Camshaft position sensor O-ring | 26. Camshaft position sensor (EXH) | 27. Camshaft position sensor (INT) |
| A. Refer to INSTALLATION | B. Refer to INSTALLATION | ← Front |

Removal and Installation

INFOID:0000000011279967

REMOVAL

1. Remove the rocker cover. Refer to [EM-42. "Removal and Installation"](#).
2. Remove camshaft position sensors.
3. Remove camshaft position sensor bracket.
4. Remove the valve timing control cover. Refer to [EM-80. "Valve Timing Control Cover"](#).

CAMSHAFT

< REMOVAL AND INSTALLATION >

5. Set the No.1 cylinder at TDC on its compression stroke using the following procedure:
- Rotate crankshaft pulley clockwise, and align mating mark for TDC (B) with timing indicator (A) on front cover, as shown.

NOTE:

Do not use the white paint mark (C).

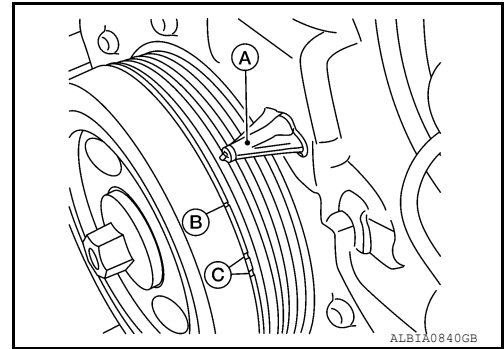

- At the same time, make sure that the mating marks (outer groove) (B) on camshaft sprockets are lined up with the pink links (A) in the timing chain, as shown.

- If not, rotate crankshaft pulley one more turn to line up the mating marks (outer groove) (B) to the pink links (A), as shown.

NOTE:

Shown with front cover removed for illustration purposes only.

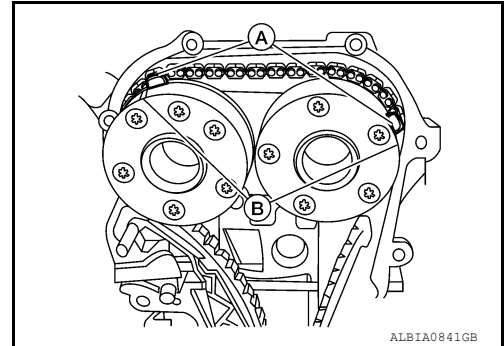

6. Remove chain tensioner (1) and timing chain using the following procedure:

- Pull the lever (B) down and release the plunger stopper tab (C).
 - Plunger stopper tab (C) can be pushed up to release (coaxial structure with lever (B)).
- Insert the stopper pin (A) into the tensioner body hole to hold the lever (B) and keep tab released.

NOTE:

Allen wrench [2.5 mm (0.098)] is used for a stopper pin as an example.

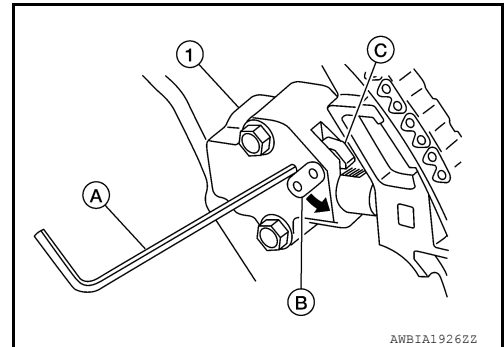

- Insert plunger (C) into tensioner body by pressing timing chain slack guide (1).
- Keep timing chain slack (1) guide pressed and hold it by pushing the stopper pin (B) through the lever hole and body hole.
- Remove the chain tensioner bolts (A) and chain tensioner.

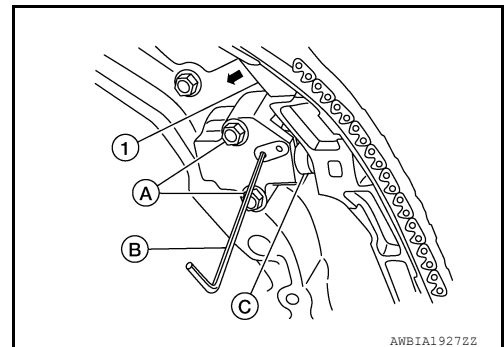

- Remove the timing chain from camshaft sprocket (INT) and camshaft sprocket (EXH).

CAUTION:

- Use suitable tool to prevent timing chain from falling into front cover after it has been removed from camshaft sprocket (INT) and camshaft sprocket (EXH).
- Do not rotate the crankshaft or camshafts while the timing chain is removed. It can cause damage to the valves and pistons.

CAMSHAFT

< REMOVAL AND INSTALLATION >

7. Remove the camshaft sprockets using the following procedure:
 - a. Secure hexagonal part of the camshaft with a suitable tool and loosen the camshaft sprocket bolt.
 - b. Remove the camshaft sprocket bolt and camshaft sprockets for both camshafts.

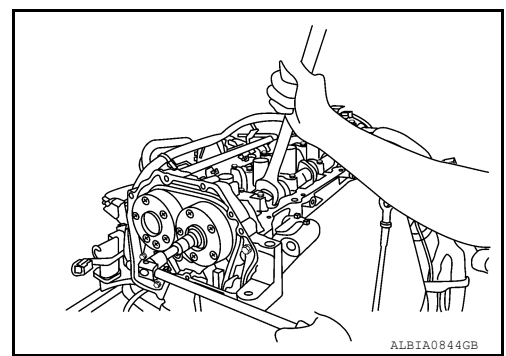

8. Loosen the camshaft bracket bolts in the order as shown, and remove the camshaft brackets and camshafts.

NOTE:

Remove camshaft bracket (No. 1) by slightly tapping it with a rubber mallet.

- (A) : Intake side
- (B) : Exhaust side
- ↶ : Engine front

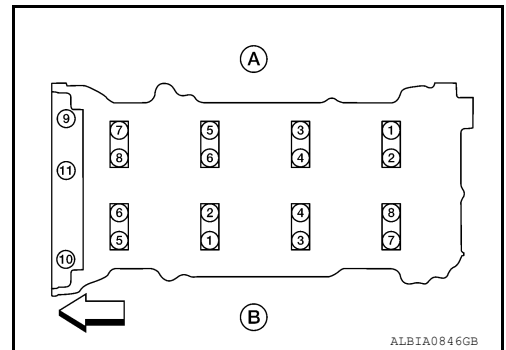

9. Remove the valve lifters.

NOTE:

Check installation positions, and set them aside in the order removed.

INSPECTION AFTER REMOVAL

Camshaft Runout

1. Put the camshaft on a V-block supporting the No.2 and No.5 journals.

CAUTION:

Do not support the No. 1 journal (on the side of the camshaft sprocket) because it has different diameter from the other four locations.

2. Set suitable tool (A) vertically on the No.3 journal.
3. Turn camshaft in one direction by hand, and measure the camshaft runout on the dial gauge total indicator reading.

Standard : Refer to [EM-121, "Camshaft"](#)

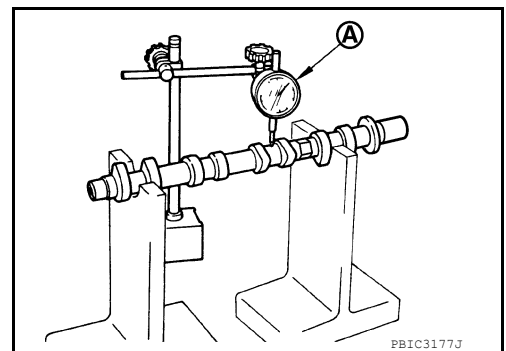

Camshaft Cam Height

1. Measure the camshaft cam height using suitable tool (A).

Standard intake cam height : Refer to [EM-121, "Camshaft"](#)

Standard exhaust cam height : Refer to [EM-121, "Camshaft"](#)

2. If wear is beyond the limit, replace the camshaft.

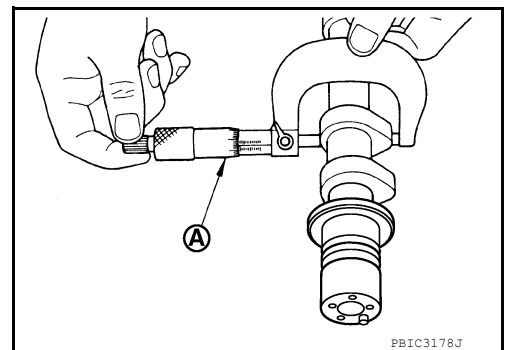

Camshaft Journal Clearance

Outer Diameter of Camshaft Journal

CAMSHAFT

< REMOVAL AND INSTALLATION >

- Measure the outer diameter of the camshaft journal using suitable tool (A).

Standard No.1 outer diameter : Refer to [EM-121, "Camshaft"](#)

Standard No.2, 3, 4, 5, outer diameter : Refer to [EM-121, "Camshaft"](#)

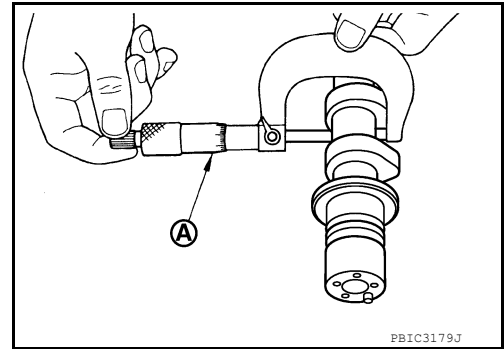

Inner Diameter of Camshaft Bracket

- Tighten the camshaft bracket bolts to the specified torque following the tightening pattern as shown.

Step 1 (bolts 9 - 11) : 1.96 N·m (0.20 kg-m, 17 in-lb)

Step 2 (bolts 1 - 8) : 1.96 N·m (0.20 kg-m, 17 in-lb)

Step 3 (bolts 1 - 11) : 5.88 N·m (0.60 kg-m, 52 in-lb)

Step 4 (bolts 1 - 11) : 10.41 N·m (1.1 kg-m, 8 ft-lb)

(A) : Intake side

(B) : Exhaust side

↙ : Engine front

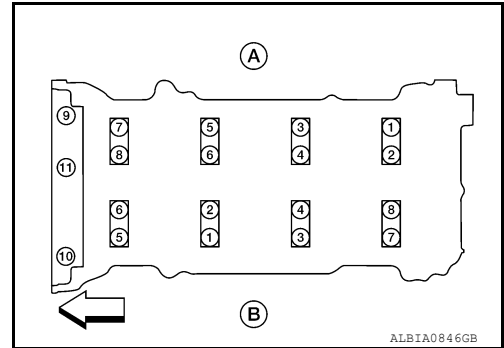

- Using suitable tool (A), measure inner diameter of camshaft bracket (1).

Standard No.1 : Refer to [EM-121, "Camshaft"](#)

Standard No.2, 3, 4, 5 : Refer to [EM-121, "Camshaft"](#)

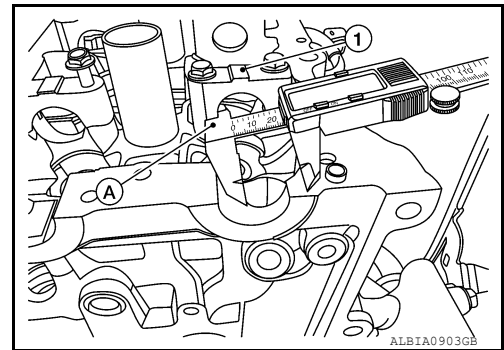

Calculation of Camshaft Journal Clearance

- (Journal clearance) = (inner diameter of camshaft bracket) – (outer diameter of camshaft journal)

Standard : Refer to [EM-121, "Camshaft"](#)

- When out of the specified range above, replace either or both the camshaft and the cylinder head assembly.

NOTE:

Inner diameter of the camshaft bracket is manufactured together with the cylinder head. If the camshaft bracket is out of specification, replace the whole cylinder head assembly.

Camshaft End Play

CAMSHAFT

< REMOVAL AND INSTALLATION >

1. Install suitable tool (A) in the thrust direction on the front end of the camshaft. Measure the end play with the dial gauge while moving the camshaft forward and backward (in direction to axis).

Standard end play : Refer to [EM-121, "Camshaft"](#)

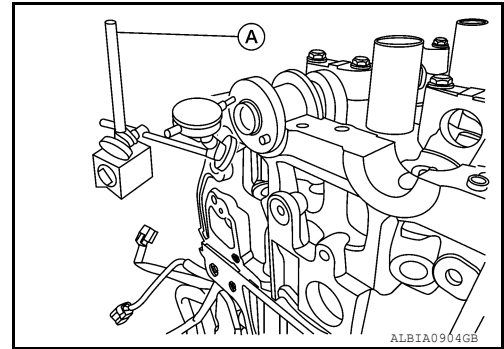

- Measure the following parts if out of the standard.
- Dimension (A) for camshaft No. 1 journal

Standard : Refer to [EM-121, "Camshaft"](#)

- Dimension (B) for cylinder head No. 1 journal

Standard : Refer to [EM-121, "Camshaft"](#)

- Refer to the standards above, and then replace camshaft and/or cylinder head.

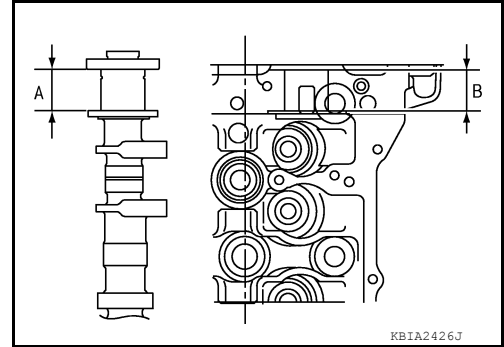

Camshaft Sprocket Runout

1. Install the camshaft in the cylinder head.
2. Install the camshaft sprocket on the camshaft.
3. Measure camshaft sprocket runout while turning the camshaft by hand using suitable tool (A).

Runout : Refer to [EM-121, "Camshaft"](#)

4. If it exceeds the specification, replace camshaft sprocket.

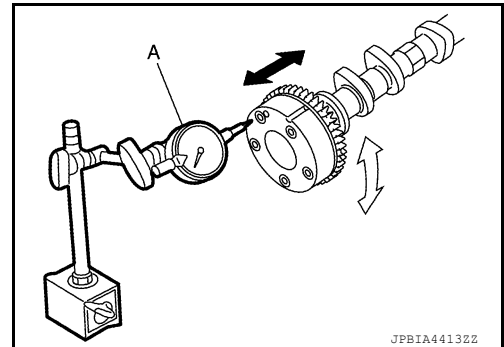

Valve Lifter

- Check if the surface of the valve lifter has any excessive wear or cracks, replace as necessary.

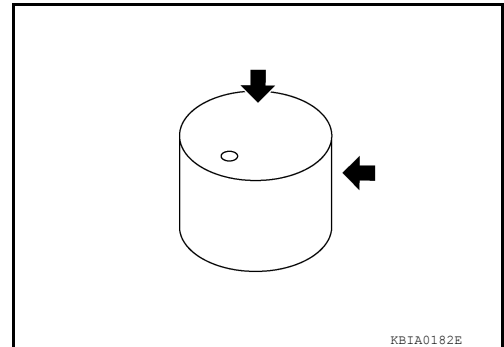

Valve Lifter Clearance

Outer Diameter of Valve Lifter

CAMSHAFT

< REMOVAL AND INSTALLATION >

- Measure the outer diameter of the valve lifter using suitable tool (A).

Valve lifter outer diameter : Refer to [EM-121, "Camshaft"](#)

- If out of the specified range, replace the valve lifter.

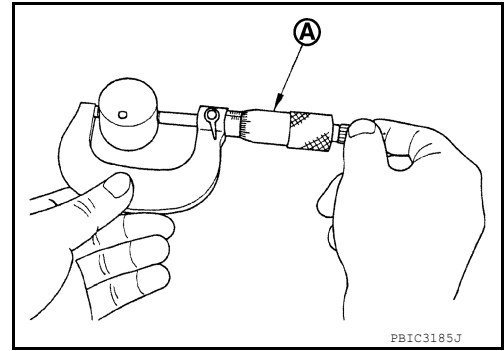

Valve Lifter Bore Inner Diameter

- Measure diameter of valve lifter bore of cylinder head using suitable tool (A).

Standard : Refer to [EM-121, "Camshaft"](#)

- If out of the specified range, replace the cylinder head assembly.

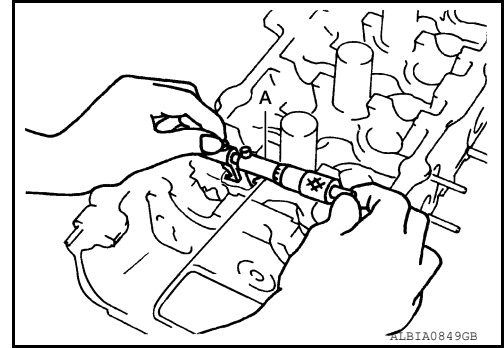

Calculation of Valve Lifter Clearance

- (Valve lifter clearance) = (hole diameter for valve lifter) – (outer diameter of valve lifter)

Standard : Refer to [EM-121, "Camshaft"](#)

- If out of specified range, replace either or both valve lifter and cylinder head assembly.

INSTALLATION

1. Install the valve lifter.
 - Install them in the same position from which they were removed.
2. Install the camshafts.

- (1) : Exhaust camshaft
- (2) : Intake camshaft

NOTE:

The distinction between the intake and exhaust camshafts is the difference in the shape of the rear.

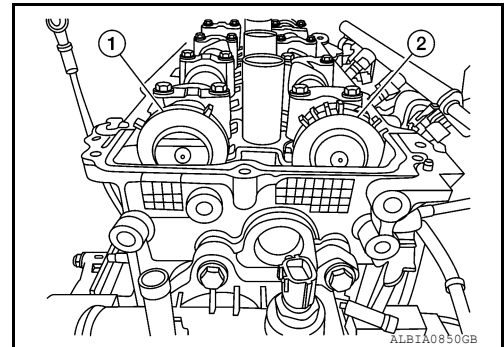

- Install camshafts so that the dowel pins (A) on the front side are positioned as shown.

- (1) : Intake camshaft
- (2) : Exhaust camshaft

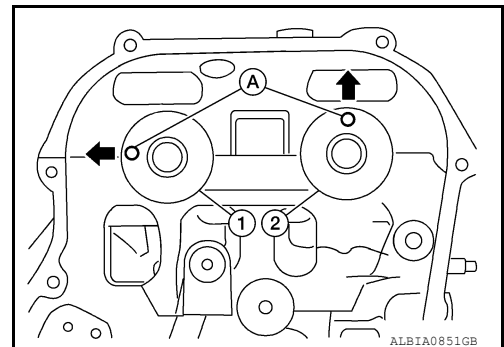

CAMSHAFT

< REMOVAL AND INSTALLATION >

3. Install camshaft brackets.

- Install by referring to identification mark on upper surface mark.
- Install so that identification mark can be correctly read when viewed from the exhaust side.

- (A) : Intake side
 (B) : Exhaust side
 ⇐ : Engine front

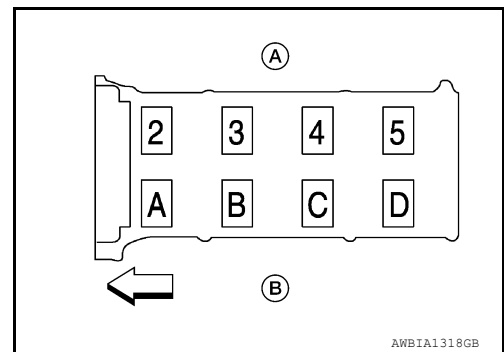

- Install camshaft bracket (No. 1) as follows.
- Apply liquid gasket to camshaft bracket (No. 1) as shown (A - C). Refer to [EM-6. "Precaution for Liquid Gasket"](#).

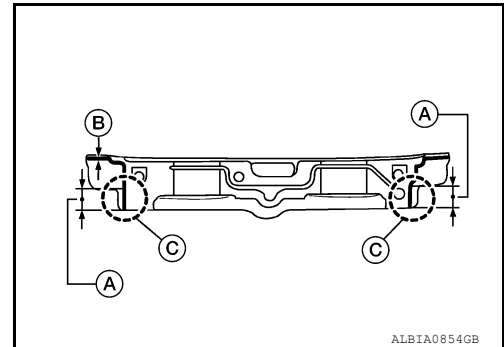

- Apply liquid gasket to camshaft bracket (No. 1) contact surface on the front cover backside. Refer to [EM-6. "Precaution for Liquid Gasket"](#)

(a) : 3.4 - 4.4 mm (0.134-0.173 in)

- (1) : Front cover

- Apply liquid gasket to the outside of bolt hole on front cover. Refer to [EM-6. "Precaution for Liquid Gasket"](#)

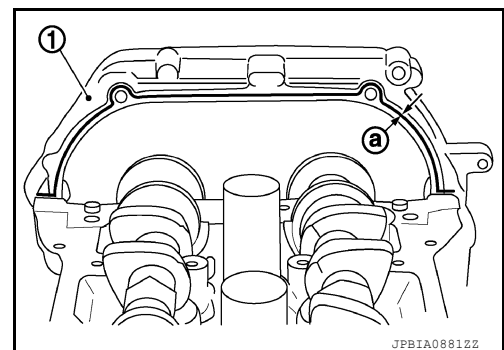

- Position the camshaft bracket (No. 1) near the installation position, and install it without disturbing the liquid gasket applied to the surfaces.

- (1) : Camshaft bracket (No. 1)
 (2) : Front cover

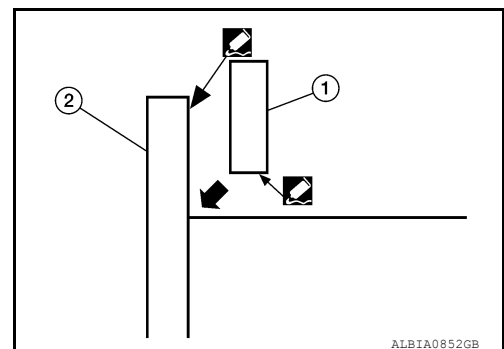

CAMSHAFT

< REMOVAL AND INSTALLATION >

4. Tighten camshaft bracket bolts in four steps in the order as shown.

- Step 1 (bolts 9 - 11) : 1.96 N·m (0.20 kg-m, 17 in-lb)**
Step 2 (bolts 1 - 8) : 1.96 N·m (0.20 kg-m, 17 in-lb)
Step 3 (bolts 1 - 11) : 5.88 N·m (0.60 kg-m, 52 in-lb)
Step 4 (bolts 1 - 11) : 10.41 N·m (1.1 kg-m, 8 ft-lb)

- (A) : Intake side
(B) : Exhaust side
⇐ : Engine front

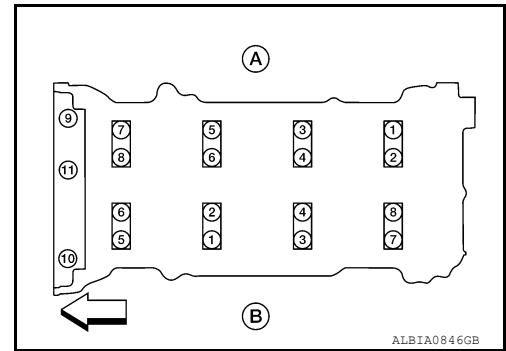

CAUTION:

After tightening camshaft bracket bolts, be sure to wipe off excessive liquid gasket from the parts listed below.

- Mating surface of rocker cover.
- Mating surface of front cover, when installed without the front cover.

5. Install camshaft sprockets.
- Install them by lining up the mating marks (outer groove) (B) on each camshaft sprocket with the painted marks (A) on the timing chain during removal.
 - Before installation of chain tensioner, it is possible to re-match the painted marks (A) on timing chain with the mating marks (B) on each sprocket.

CAUTION:

- Aligned mating marks could slip. Therefore, after matching them, hold the timing chain in place by hand.
- Before and after installing chain tensioner, check again to make sure that mating marks have not slipped.

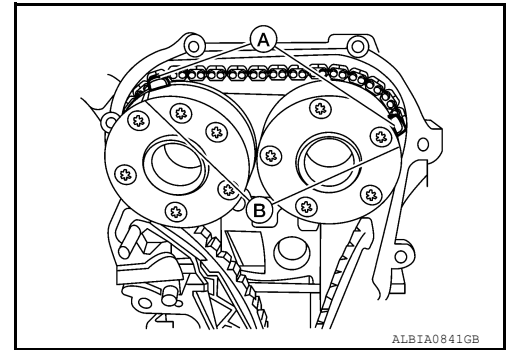

6. Install timing chain tension guide.
7. Install chain tensioner using the following procedure:
- a. Install stopper pin (A) into the chain tensioner (1).
 - b. Install the chain tensioner and pull the stopper pin out.

CAUTION:

After installation, pull the stopper pin out, and make sure that the tensioner is fully released.

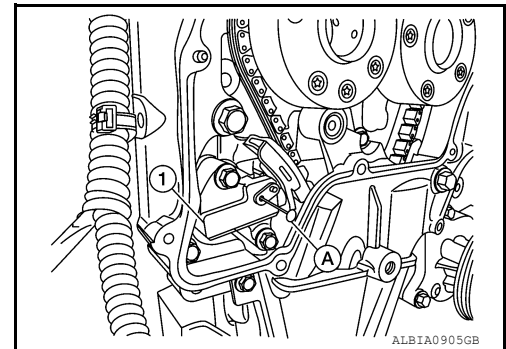

8. Install intake valve timing control cover with the following procedure.
- a. Install intake valve timing intermediate lock control solenoid valve, intake valve timing control solenoid valve, and exhaust valve timing control solenoid valve to valve timing control cover.

CAUTION:

Do not reuse O-ring.

- b. Install O-ring to front cover side.

CAUTION:

Do not reuse O-ring.

CAMSHAFT

< REMOVAL AND INSTALLATION >

- c. Apply liquid gasket to the positions shown. Refer to [GI-22. "Recommended Chemical Products and Sealants"](#).

Diameter (A) : 3.4 - 4.4 mm (0.134 - 0.173 in)

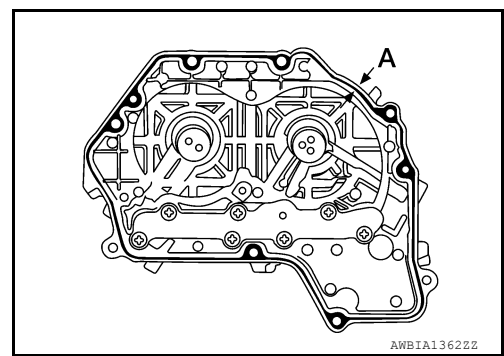

- d. Install valve timing control cover.
- Tighten the bolts to specification in the numerical order as shown.

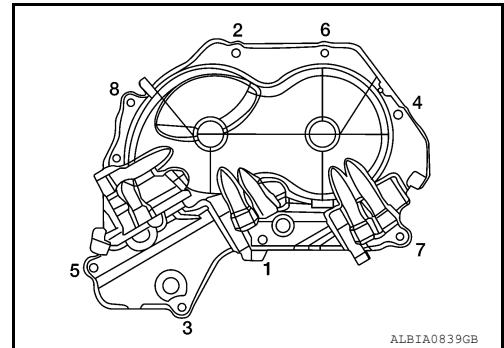

9. Check and adjust valve clearances. Refer to [EM-21. "Camshaft valve clearance"](#).
 10. Install camshaft position sensor bracket.

- a. Apply liquid gasket to camshaft position sensor bracket as shown.

(A) : 2.0 - 3.0 mm (0.079-0.118)

(B) : 10.5 mm (0.413 in)

CAUTION:

- Use Genuine Silicone RTV Sealant, or equivalent. Refer to [GI-22. "Recommended Chemical Products and Sealants"](#).
- After installation be sure to wipe off excessive liquid gasket leaking from part (B).
- Installation should be done within 5 minutes after applying liquid gasket.
- Do not fill the engine with engine oil for at least 30 minutes after the components are installed to allow the liquid gasket to cure.

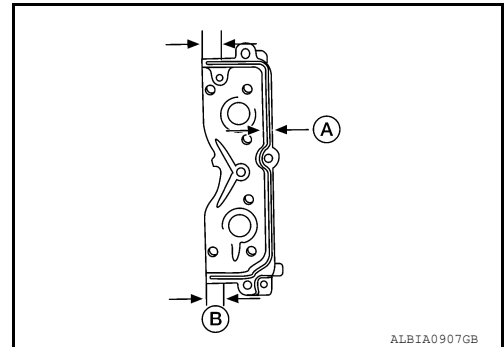

- b. Tighten bolts to specification in numerical order shown.

Camshaft position sensor bracket bolts : 10.41 N·m (1.1 kg-m, 8 ft-lb)

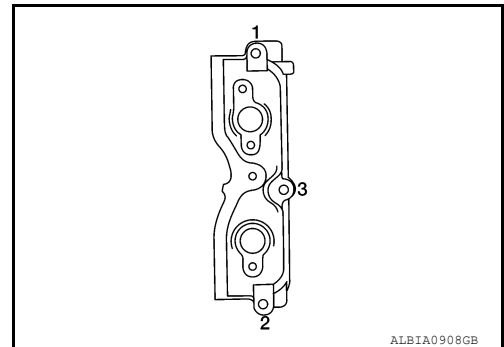

11. Install the camshaft position sensors. Refer to [EM-69. "Exploded View"](#).
 12. Installation of the remaining components is in the reverse order of removal.

Inspection After Installation

INFOID:000000011279968

Inspection of Camshaft Sprocket (INT) Oil Groove and Camshaft Sprocket (EXH) Oil Groove

CAMSHAFT

< REMOVAL AND INSTALLATION >

WARNING:

Check when engine is cold so as to prevent burns from any splashing engine oil.

CAUTION:

Perform this inspection only when DTC P0011, P0014, P052A, P052B is detected in self-diagnostic results of CONSULT and it is directed according to inspection procedure of EC section.

1. Check engine oil level and adjust oil level as necessary. Refer to [LU-7, "Inspection"](#).
2. Remove the intake valve timing intermediate lock control solenoid valve, intake valve timing control solenoid valve, and exhaust valve timing control solenoid valve. Refer to [EM-79, "Intake Valve Timing Intermediate Lock Control Solenoid Valve, Intake Valve Timing Control Solenoid Valve, and Exhaust Valve Timing Control Solenoid Valve"](#).
3. Perform the following procedure to prevent the engine from being unintentionally started while checking.
 - a. Release fuel pressure. Refer to [EC-147, "Work Procedure"](#).
 - b. Disconnect injector harness connectors.
4. Crank engine, and then make sure that engine oil comes out of the valve timing control cover oil holes (A). End cranking after checking.

WARNING:

Be careful not to touch rotating parts (drive belt, crankshaft pulley, etc.).

CAUTION:

- Engine oil may squirt from intake valve timing intermediate lock control solenoid valve, intake valve timing control solenoid valve, exhaust valve timing control solenoid valve installation holes during cranking. Use a shop cloth to prevent engine oil from splashing on worker, engine components and vehicle.
 - Do not allow engine oil to get on rubber components such as drive belts or engine mount insulators. Immediately wipe off any splashed engine oil.
5. If engine oil does not come out from valve timing control cover oil holes (A), diagnose problem in lubrication circuit such as dirty oil groove between oil strainer and intake valve timing intermediate lock control solenoid valve, intake valve timing control solenoid valve, or exhaust valve timing control solenoid valve. Refer to [LU-5, "Engine Lubrication System"](#).
 - a. Remove components between intake valve timing intermediate lock control solenoid valve, intake valve timing control solenoid valve, exhaust valve timing control solenoid valve and camshaft sprocket (INT) or camshaft sprocket (EXH), (if necessary) and then check each oil groove for clogging.
 - b. Clean oil groove if necessary. Refer to [LU-5, "Engine Lubrication System"](#).
 6. After inspection, install the remaining components in the reverse order of removal.

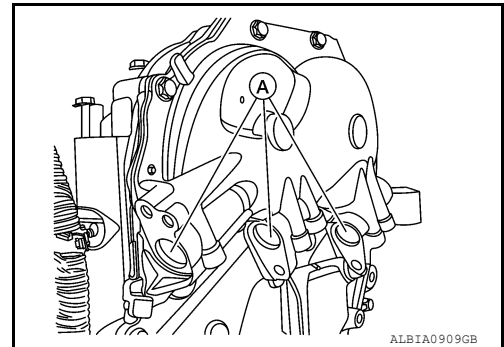

VALVE TIMING CONTROL

< REMOVAL AND INSTALLATION >

VALVE TIMING CONTROL

Exploded View

INFOID:000000011279969

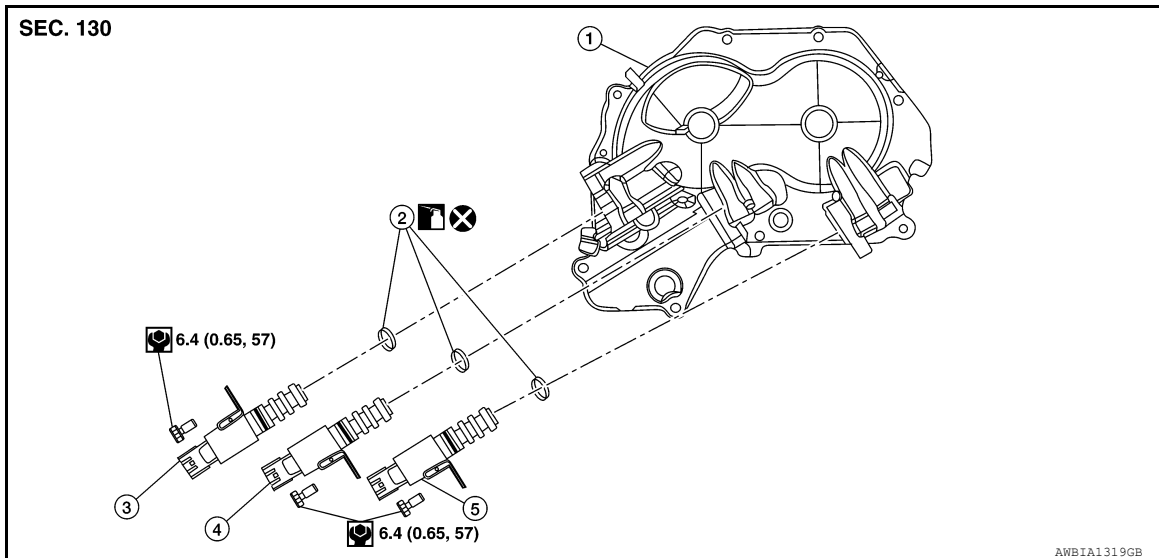

- | | | |
|---|--|---|
| 1. Valve timing cover | 2. O-rings | 3. Intake valve timing intermediate lock control solenoid valve |
| 4. Intake valve timing control solenoid valve | 5. Exhaust valve timing control solenoid valve | |

Intake Valve Timing Intermediate Lock Control Solenoid Valve, Intake Valve Timing Control Solenoid Valve, and Exhaust Valve Timing Control Solenoid Valve

INFOID:000000011279970

REMOVAL

1. Disconnect the battery negative terminal. Refer to [PG-78. "Exploded View"](#).
2. Remove cowl top extension. Refer to [EXT-25. "Removal and Installation"](#).
3. Remove the RH engine mount torque rod. Refer to [EM-86. "Exploded View"](#).
4. Use a suitable jack (A) to securely support the bottom of the engine (1) and the transaxle assembly (2).

CAUTION:

Put a piece of wood or an equivalent as the supporting surface and secure in a stable condition.

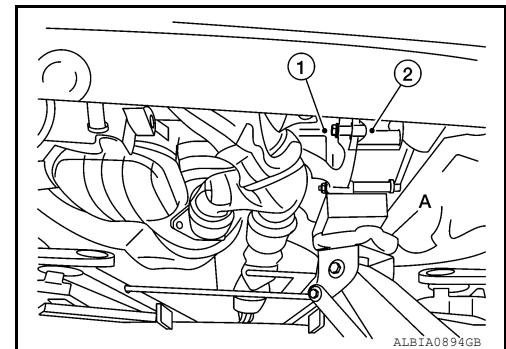

5. Remove A/C line bracket bolt.
6. Remove harness grounds from engine mounting bracket (RH).
7. Remove harness retainers from engine mounting bracket (RH).
8. Remove the engine mounting bracket (RH). Refer to [EM-86. "Exploded View"](#).
9. Remove the RH engine mounting support bracket. Refer to [EM-86. "Exploded View"](#).
10. Remove the RH engine mount torque rod. Refer to [EM-86. "Exploded View"](#).
11. Disconnect harness connectors from intake valve timing intermediate lock control solenoid valve, intake valve timing control solenoid valve, and exhaust valve timing control solenoid valve connectors.

VALVE TIMING CONTROL

< REMOVAL AND INSTALLATION >

12. Remove intake valve timing intermediate lock control solenoid valve, intake valve timing control solenoid valve, and exhaust valve timing control solenoid valve bolts.
13. Remove intake valve timing intermediate lock control solenoid valve, intake valve timing control solenoid valve, exhaust valve timing control solenoid valve from valve timing control cover.
14. Remove O-rings from intake valve timing intermediate lock control solenoid valve, intake valve timing control solenoid valve, and exhaust valve timing control solenoid valve.

INSTALLATION

Installation is in the reverse order of removal.

CAUTION:

- Do not reuse O-rings.
- Lubricate O-rings with clean engine oil before installing.

Valve Timing Control Cover

INFOID:000000011279971

REMOVAL

1. Remove the intake valve timing intermediate lock control solenoid valve, intake valve timing control solenoid valve, exhaust valve timing control solenoid valve. Refer to [EM-79, "Intake Valve Timing Intermediate Lock Control Solenoid Valve, Intake Valve Timing Control Solenoid Valve, and Exhaust Valve Timing Control Solenoid Valve"](#).
2. Remove harness grounds and retainers from the top of the engine mount bracket.
3. Loosen the valve timing control cover bolts in the reverse order shown.
 - a. Remove the valve timing control cover bolts.

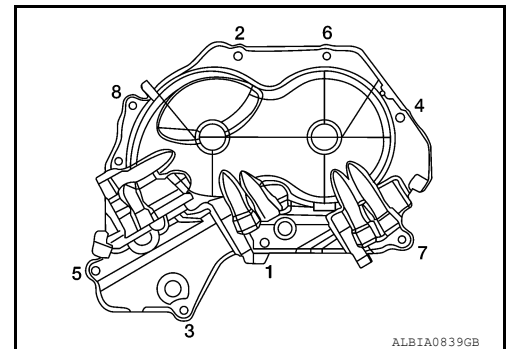

- b. Remove the valve timing control cover by cutting the liquid gasket using Tool (A).

Tool number : KV10111100 (J-37228)

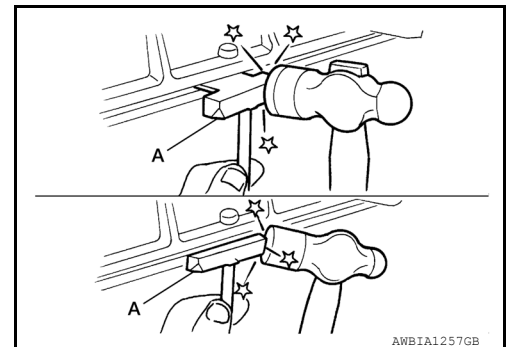

NOTE:

Do not loosen screws (A) on the back of the valve timing control cover.

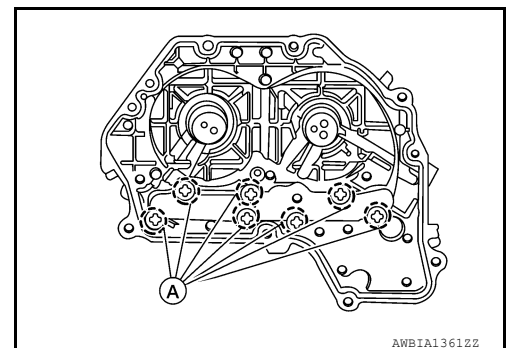

VALVE TIMING CONTROL

< REMOVAL AND INSTALLATION >

INSTALLATION

1. Install valve timing control cover with the following procedure.
 - a. Install intake valve timing intermediate lock control solenoid valve, intake valve timing control solenoid valve and exhaust valve timing control solenoid valve to valve timing control cover.
 - b. Install O-ring to front cover side.

CAUTION:

Do not reuse O-ring.

- c. Apply liquid gasket to the positions shown. Refer to [GI-22. "Recommended Chemical Products and Sealants"](#).

Diameter (A) : 3.4 - 4.4 mm (0.134 - 0.173 in)

- d. Install valve timing control cover.
 - Tighten the bolts to specification in the numerical order shown.

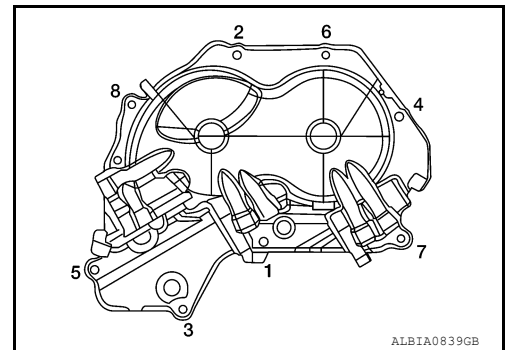
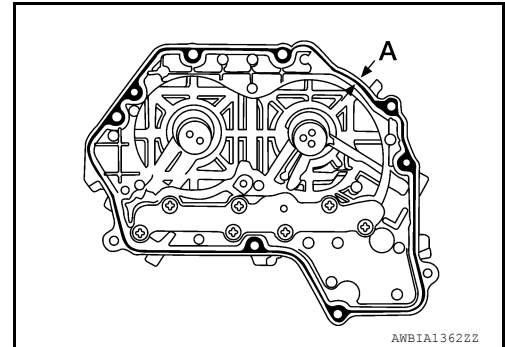

A

EM

C

D

E

F

G

H

I

J

K

L

M

N

O

P

OIL SEAL

< REMOVAL AND INSTALLATION >

OIL SEAL

VALVE OIL SEAL

VALVE OIL SEAL : Removal and Installation

INFOID:000000011279972

REMOVAL

1. Remove camshafts. Refer to [EM-69. "Removal and Installation"](#).
2. Remove valve lifters. Refer to [EM-61. "Disassembly and Assembly"](#).
3. Rotate crankshaft, and set piston whose valve oil seal is to be removed to TDC. This will prevent valve from dropping into cylinder.

CAUTION:

When rotating crankshaft, be careful to avoid scarring front cover with timing chain.

4. Remove valve collet.
 - Compress valve spring using suitable tool (A). Remove valve collet with a magnet.

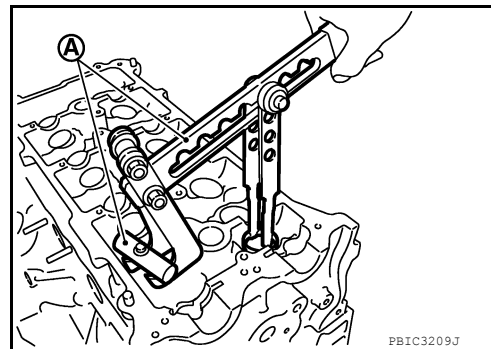

CAUTION:

- Be careful not to damage valve lifter holes.
- Install suitable tool (A) in the center of valve spring retainer (1) to press it.

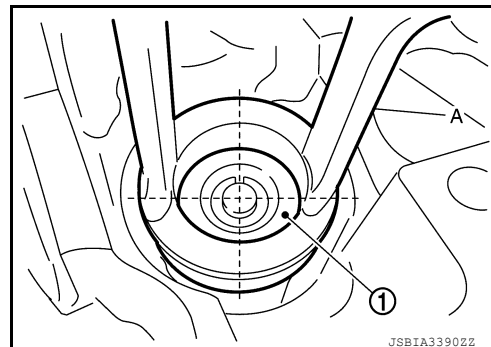

5. Remove valve spring retainer and valve spring (with valve spring seat).

CAUTION:

Do not remove valve spring seat from valve spring.

6. Remove valve oil seal using suitable tool (A).

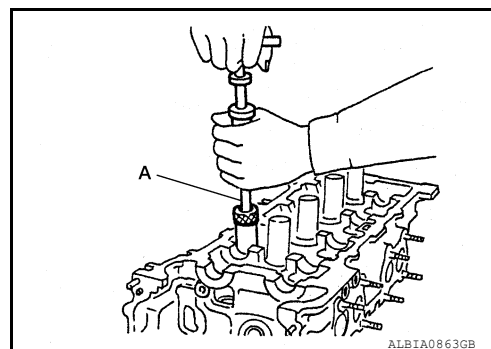

INSTALLATION

1. Apply new engine oil to valve oil seal joint surface and seal lip.

OIL SEAL

< REMOVAL AND INSTALLATION >

2. Press in valve oil seal to the height "H" as shown using suitable tool (A).

Height "H" : Refer to [EM-122. "Cylinder Head"](#)

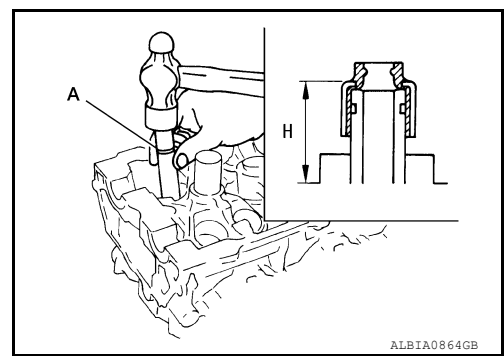

3. Installation of the remaining components is in the reverse order of removal.

FRONT OIL SEAL

FRONT OIL SEAL : Removal and Installation

INFOID:0000000011279973

REMOVAL

1. Remove engine undercover. Refer to [EXT-37. "ENGINE UNDER COVER : Removal and Installation"](#).
2. Remove front fender protector. Refer to [EXT-28. "FENDER PROTECTOR : Removal and Installation"](#).
3. Remove drive belt. Refer to [EM-15. "Removal and Installation"](#).
4. Remove crankshaft pulley (1) using the following procedure:
 - a. Hold the crankshaft pulley (1) using suitable tool (A), then loosen and remove the crankshaft pulley bolt.

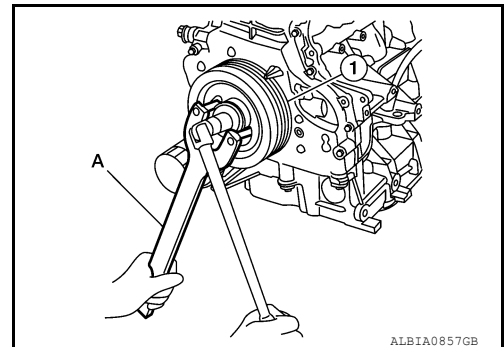

- b. Attach suitable tool (A) in the threaded hole on crankshaft pulley (1), and remove crankshaft pulley.

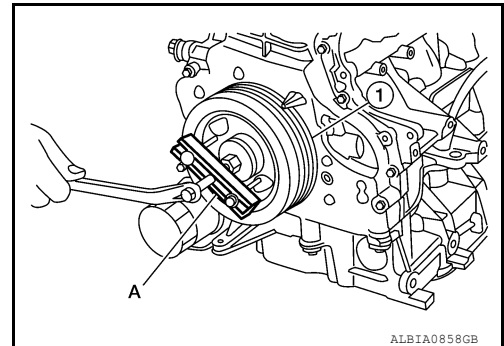

5. Remove front oil seal with a suitable tool.
CAUTION:
Do not damage front cover and crankshaft.

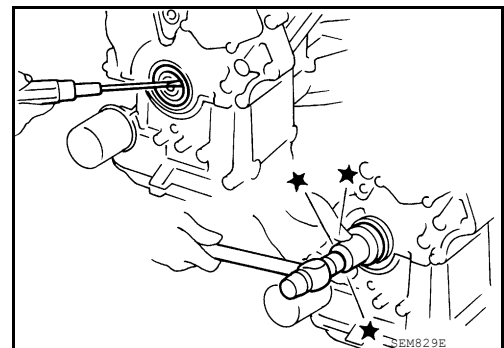

INSTALLATION

OIL SEAL

< REMOVAL AND INSTALLATION >

1. Apply new engine oil to seal lip.
2. Install front oil seal so that each seal lip is oriented as shown.

- (A) : Dust seal lip
- (B) : Oil seal lip
- ⇐ : Engine outside
- ⇨ : Engine inside

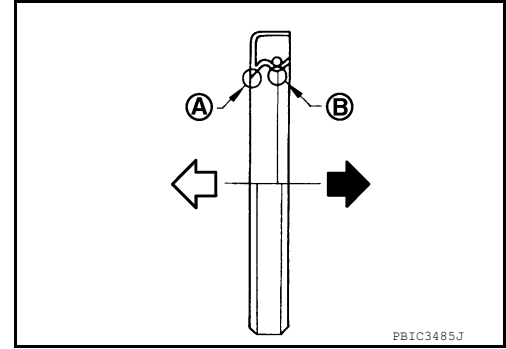

- Press-fit front oil seal until it is flush with front end surface of front cover using a suitable drift (A).

CAUTION:

- Do not damage front cover and crankshaft.
- Press-fit oil seal straight to avoid causing burrs or tilting.
- Do not touch the grease applied to the oil seal lip.
- Do not reuse oil seal.

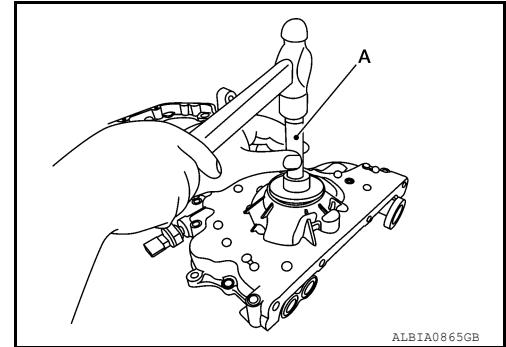

3. Insert crankshaft pulley (2) by aligning with crankshaft key.
 - Tap its center with a plastic hammer to insert.
 - Do not tap the crankshaft pulley outer diameter.
 4. Tighten crankshaft pulley bolt.
 - Secure crankshaft pulley with suitable tool to tighten the bolt.
 - Perform angle tightening with the following procedure.
- a. Apply new engine oil to threads and seat surfaces of bolts.
 - b. Apply a paint mark (A) on the front cover, mating with any one of six easy to recognize stamp marks on bolt flange (B).
 - c. Tighten crankshaft bolt (1) to specification.

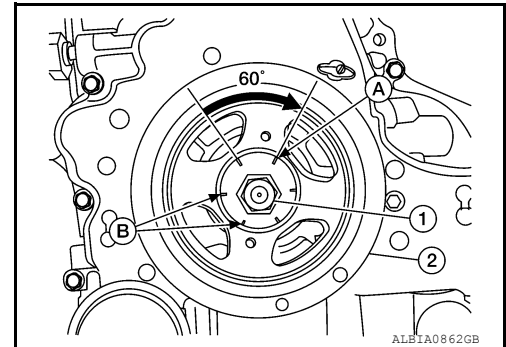

NOTE:

Check that the assembled unit does not interfere with adjacent components by turning the crankshaft in the tightening direction.

Step 1 : 42.1 N·m (4.3 kg-m, 31 ft-lb)

Step 2 : Turn crankshaft bolt (1) an additional 60° +6°/-0°.

5. Installation of the remaining components is in the reverse order of removal.

REAR OIL SEAL

REAR OIL SEAL : Removal and Installation

INFOID:000000011279974

REMOVAL

1. Remove the engine and transaxle. Refer to [EM-86, "Removal and Installation \(FWD\)"](#) and [EM-90, "Removal and Installation \(AWD\)"](#).
2. Separate engine from transaxle.
3. Remove drive plate. Refer to [EM-97, "Exploded View"](#).
4. Remove rear oil seal with a suitable tool.

CAUTION:

Be careful not to damage crankshaft and cylinder block.

OIL SEAL

< REMOVAL AND INSTALLATION >

INSTALLATION

1. Apply new engine oil to rear oil seal lip.
2. Install rear oil seal so that each seal lip is oriented as shown.

- (A) : Dust seal lip
- (B) : Oil seal lip
- ⇐ : Engine outside
- ➡ : Engine inside

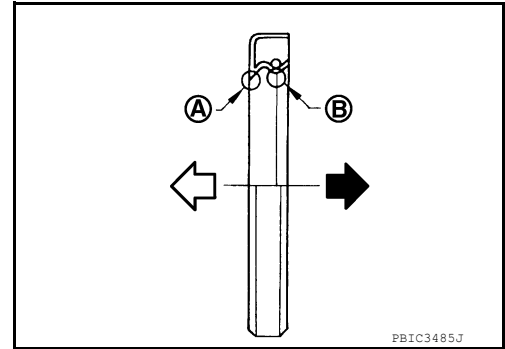

- Press-fit rear oil seal with a suitable drift.

CAUTION:

- Do not damage crankshaft and cylinder block.
- Press-fit oil seal straight to avoid causing burrs or tilting.
- Do not touch grease applied onto oil seal lip.
- Apply neutral detergent (if needed) to outer circumference of oil seal to aid installation. Do not allow detergent to contact inner circumference of oil seal.

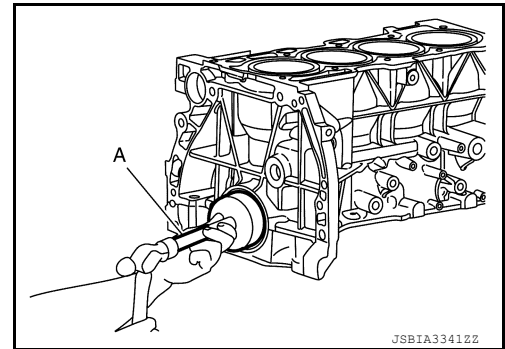

- Press in the new rear oil seal (1) to the position as shown.

- (A) : Rear end surface of cylinder block
- (b) : 0.0 mm - 0.5 mm (0.000 in - 0.020 in)

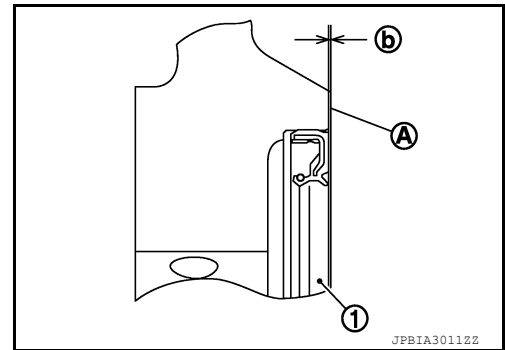

3. Installation of the remaining components is in the reverse order of removal.

ENGINE ASSEMBLY

< UNIT REMOVAL AND INSTALLATION >

UNIT REMOVAL AND INSTALLATION

ENGINE ASSEMBLY

Exploded View

INFOID:0000000011279975

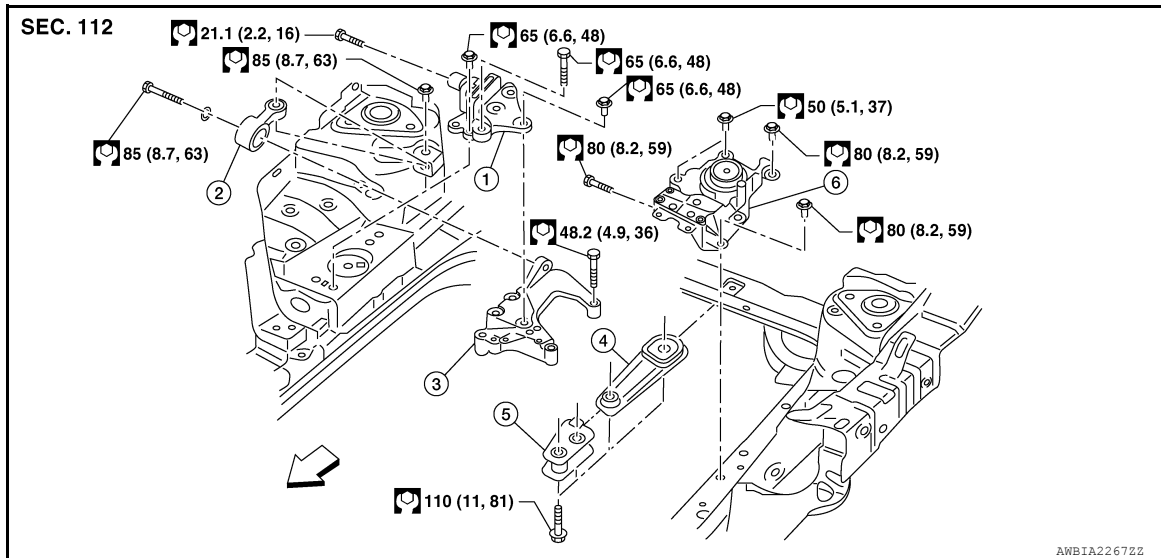

- | | | |
|-----------------------------------|-----------------------------|-----------------------------------|
| 1. Engine mounting insulator (RH) | 2. Upper torque rod (RH) | 3. Engine mounting bracket (RH) |
| 4. Lower torque rod | 5. Lower torque rod bracket | 6. Engine mounting insulator (LH) |

⇐ Front

Removal and Installation (FWD)

INFOID:0000000011279976

WARNING:

- Situate the vehicle on a flat and solid surface.
- Place chocks at front and back of rear wheels.
- Attach proper slingers and bolts described in PARTS CATALOG if engine slingers are not equipped.

CAUTION:

- Always be careful to work safely, avoid forceful or uninstructed operations.
- Do not start working until exhaust system and engine coolant is cool enough.
- If items or work required are not covered by the engine section, refer to the applicable sections.
- Always use the support point specified for lifting.
- Use either 2-pole lift type or separate type lift as best you can. If board-on type is used for unavoidable reasons, support at the rear axle jacking point with a transmission jack or similar tool before starting work, in preparation for the backward shift of center of gravity.
- For supporting points for lifting and jacking point at rear axle, refer to [GI-29, "Garage Jack and Safety Stand and 2-Pole Lift"](#).

NOTE:

When removing components such as hoses, tubes/lines, etc., cap or plug openings to prevent fluid from spilling.

REMOVAL

1. Remove hood assembly. Refer to [DLK-240, "HOOD ASSEMBLY : Removal and Installation"](#).
2. Relieve fuel system pressure. Refer to [EC-147, "Work Procedure"](#).
3. Remove fender protector. Refer to [EXT-28, "FENDER PROTECTOR : Removal and Installation"](#).
4. Remove battery tray. Refer to [PG-79, "Removal and Installation \(Battery Tray\)"](#).
5. Remove air cleaner and air duct. Refer to [EM-26, "Removal and Installation"](#).
6. Remove harness grounds.
7. Remove harness bracket retainer.

ENGINE ASSEMBLY

< UNIT REMOVAL AND INSTALLATION >

8. Remove relay box assembly from underhood.
9. Remove front under cover. Refer to [EXT-16, "Exploded View"](#).
10. Drain engine coolant. Refer to [CO-8, "Draining"](#).
11. Remove radiator hose (upper/lower). Refer to [CO-13, "Exploded View"](#).
12. Disconnect heater hose inlet from engine side.
13. Disconnect heater hose outlet from engine side.
14. Disconnect CVT control cable. Refer to [TM-197, "Removal and Installation"](#).
15. Remove EVAP and vacuum hose from intake manifold.
16. Remove quick connector cap from fuel hose and fuel tube.
17. Disconnect fuel hose.
18. Remove harness ground wire bolt from generator bracket.
19. Remove fuse box cover.
20. Disconnect harness connector from fuse box.
21. Disconnect harness connector from IPDM E/R.
22. Disconnect harness connector from cooling fan controller.
23. Disconnect harness connector from refrigerant pressure sensor.
24. Remove low-pressure pipe. Refer to [HA-31, "LOW-PRESSURE PIPE : Removal and Installation"](#).
25. Remove high-pressure pipe. Refer to [HA-34, "HIGH-PRESSURE PIPE : Removal and Installation"](#).
26. Remove steering knuckles (LH/RH). Refer to [FSU-10, "Exploded View"](#).
27. Remove front drive shaft (LH/RH). Refer to [FAX-19, "Removal and Installation \(LH\)"](#) and [FAX-23, "Removal and Installation \(RH\)"](#).
28. Remove front exhaust tube. Refer to [EX-5, "Exploded View"](#).
29. Remove front suspension member. Refer to [FSU-22, "Removal and Installation"](#).
30. Remove CVT fluid cooler hoses from radiator. Refer to [CO-13, "Exploded View"](#).
31. Disconnect battery negative cable ground bolt from transaxle.
32. Remove upper torque rod (RH).
33. Remove engine mounting bracket (RH).
34. Install engine slingers into front left of engine mount bracket (RH) and rear right of cylinder head.

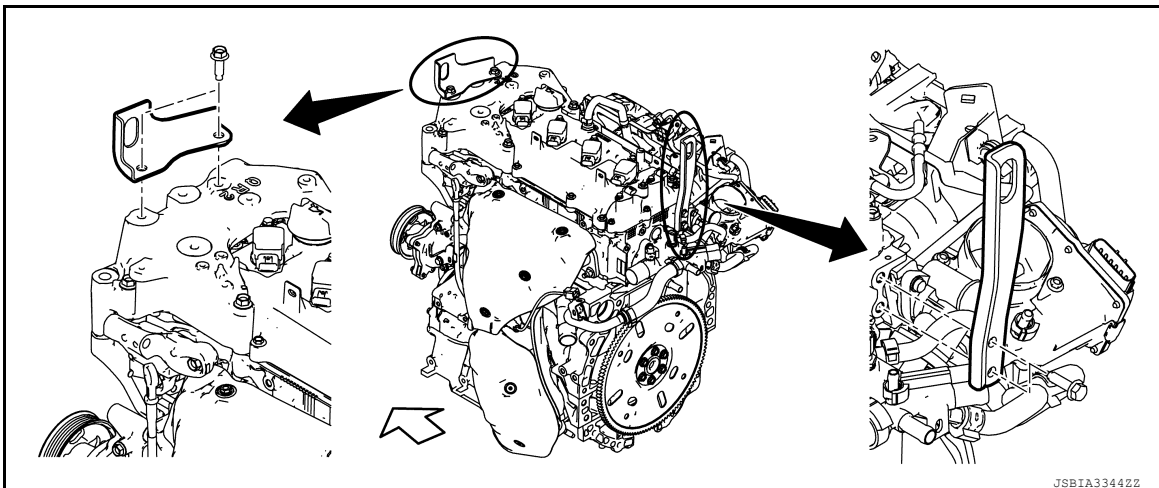

← : Engine front

Slinger bolts

Cylinder head side : 22.0 N·m (2.2 kg-m, 16 ft-lb)

Engine mount bracket side : 48.1 N·m (4.9 kg-m, 35 ft-lb)

35. Support weight of engine and transaxle assembly with a shop crane.

ENGINE ASSEMBLY

< UNIT REMOVAL AND INSTALLATION >

36. Use a suitable jack and securely support bottom of the engine and the transaxle assembly.

CAUTION:

Put a piece of wood or an equivalent as the supporting surface, secure a completely stable condition.

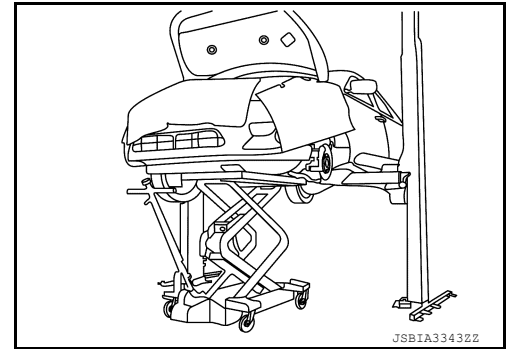

37. Slowly lower engine and transaxle assembly.

CAUTION:

- As engine and transaxle assembly is being lowered ensure there is no interference with body or engine harness connectors.
- Before and during this procedure, always check if any harnesses are left connected.
- Avoid any damage to, or any oil/grease smearing or spills onto the engine mounting insulators.

38. Disconnect harness connector from input speed sensor. Refer to [TM-207, "Removal and Installation"](#).
39. Disconnect harness connector from output speed sensor. Refer to [TM-209, "Removal and Installation"](#).
40. Disconnect harness connector from primary speed sensor. Refer to [TM-208, "Removal and Installation"](#).
41. Remove PNP switch from transaxle assembly.
42. Remove harness connector from transaxle assembly.
43. Remove starter motor. Refer to [STR-21, "Removal and Installation"](#).
44. Remove drive plate inspection cover from engine.
45. Hold drive plate with suitable tool and remove torque converter nuts.
46. Remove transaxle to engine mount bolts.
47. Separate engine and transaxle assembly.

INSTALLATION

Installation is in the reverse order of removal.

NOTE:

- Tighten drive plate bolts to specification. Refer to [EM-97, "Exploded View"](#).
- Tighten the transmission bolts to specification. Refer to [TM-220, "Exploded View"](#).
- Do not allow oil to get on mounting insulators. Be careful not to damage mounting insulators.

1. Install the engine mount insulator (RH) as follows:
- a. Temporarily tighten the bolts.
 - b. Tighten the bolts in sequence as shown to the specified torque.

↩ : Front

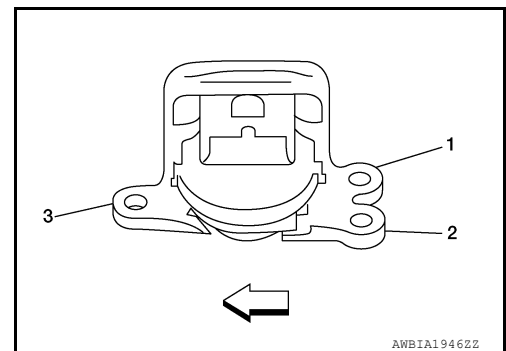

- c. Temporarily tighten the bolts.

NOTE:

ENGINE ASSEMBLY

< UNIT REMOVAL AND INSTALLATION >

Bolt is initially installed at position 1; Positions 2 - 5 are then tightened to specification.

- d. Tighten the bolts in sequence as shown to the specified torque.

↩ : Front

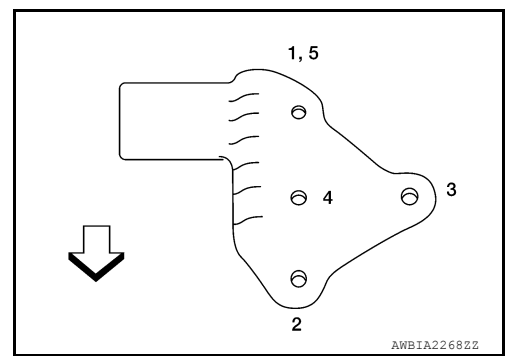

2. Install the engine mounting bracket (RH).

- a. Temporarily tighten the bolts.

NOTE:

Bolt is initially installed at position 1; Positions 2 - 5 are then tightened to specification.

- b. Tighten the bolts in sequence as shown to the specified torque.

↩ : Front

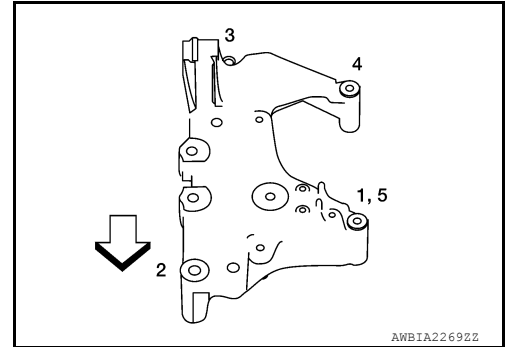

3. Install the upper torque rod (RH) as follows:

- a. Temporarily tighten bolts.

- b. Tighten the bolts in sequence as shown to the specified torque.

↩ : Front

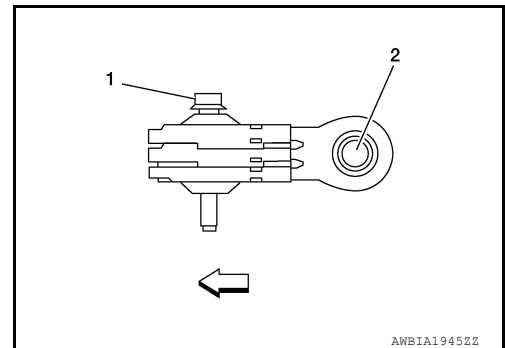

4. Install the lower torque rod bolts as follows:

- a. Temporarily tighten the bolts.

- b. Tighten the bolts in sequence as shown to the specified torque.

↩ : Front

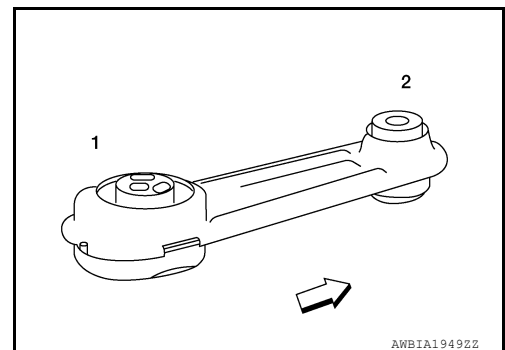

ENGINE ASSEMBLY

< UNIT REMOVAL AND INSTALLATION >

5. Install the lower torque rod bracket bolts as follows:
 - a. Temporarily tighten the bolts.
 - b. Tighten the bolts in sequence as shown to the specified torque.

↶ : Front

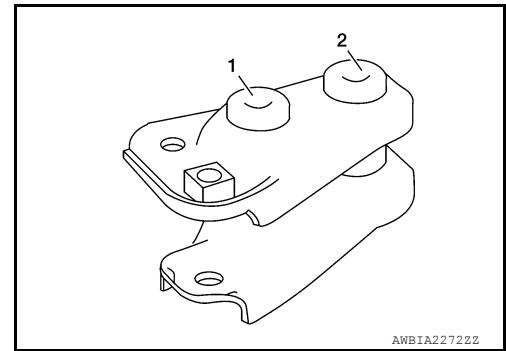

6. Install the engine mounting insulator (LH) as follows:
 - a. Temporarily tighten the bolts.
NOTE:
Bolts are initially installed at positions 1 and 2; Positions 3 - 6 are then tightened to specification.
 - b. Tighten the bolts in sequence as shown to the specified torque.

↶ : Front

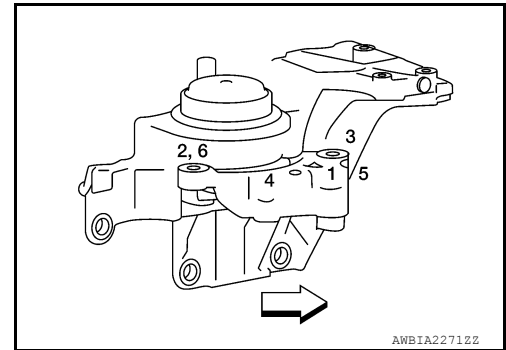

- c. Temporarily tighten the bolts.
 - d. Tighten the bolts in sequence as shown to the specified torque.

↶ : Front

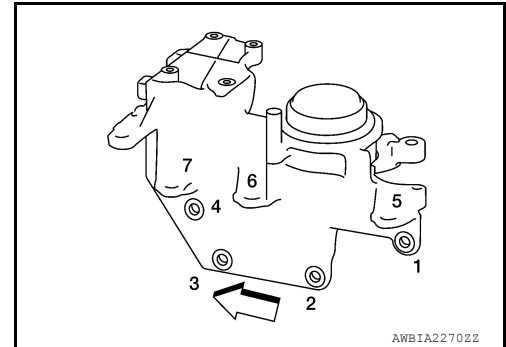

Removal and Installation (AWD)

INFOID:000000011279977

WARNING:

- Situate the vehicle on a flat and solid surface.
- Place chocks at front and back of rear wheels.
- Attach proper slingers and bolts described in PARTS CATALOG if engine slingers are not equipped.

CAUTION:

- Always be careful to work safely, avoid forceful or uninstructed operations.
- Do not start working until exhaust system and engine coolant is cool enough.
- If items or work required are not covered by the engine section, refer to the applicable sections.
- Always use the support point specified for lifting.
- Use either 2-pole lift type or separate type lift as best you can. If board-on type is used for unavoidable reasons, support at the rear axle jacking point with a transmission jack or similar tool before starting work, in preparation for the backward shift of center of gravity.
- For supporting points for lifting and jacking point at rear axle, refer to [GI-29, "Garage Jack and Safety Stand and 2-Pole Lift"](#).

NOTE:

When removing components such as hoses, tubes/lines, etc., cap or plug openings to prevent fluid from spilling.

REMOVAL

ENGINE ASSEMBLY

< UNIT REMOVAL AND INSTALLATION >

1. Remove hood assembly. Refer to [DLK-240, "HOOD ASSEMBLY : Removal and Installation"](#).
2. Relieve fuel system pressure. Refer to [EC-147, "Work Procedure"](#).
3. Remove fender protector. Refer to [EXT-28, "FENDER PROTECTOR : Removal and Installation"](#).
4. Remove battery tray. Refer to [PG-79, "Removal and Installation \(Battery Tray\)"](#).
5. Remove air cleaner and air duct. Refer to [EM-26, "Removal and Installation"](#).
6. Remove harness grounds.
7. Remove harness bracket retainer.
8. Remove relay box assembly from underhood.
9. Drain engine coolant. Refer to [CO-8, "Draining"](#).
10. Remove radiator hose (upper/lower). Refer to [CO-13, "Exploded View"](#).
11. Disconnect heater hose inlet from engine side.
12. Disconnect heater hose outlet from engine side.
13. Disconnect CVT control cable. Refer to [TM-197, "Removal and Installation"](#).
14. Remove EVAP and vacuum hose from intake manifold.
15. Remove quick connector cap from fuel hose and fuel tube.
16. Disconnect fuel hose.
17. Remove harness ground wire bolt from generator bracket.
18. Remove fuse box cover.
19. Disconnect harness connector from fuse box.
20. Disconnect harness connector from IPDM E/R.
21. Disconnect harness connector from cooling fan controller.
22. Disconnect harness connector from refrigerant pressure sensor.
23. Remove low-pressure pipe. Refer to [HA-31, "LOW-PRESSURE PIPE : Removal and Installation"](#).
24. Remove high-pressure pipe. Refer to [HA-34, "HIGH-PRESSURE PIPE : Removal and Installation"](#).
25. Remove steering knuckles (LH/RH). Refer to [FSU-10, "Exploded View"](#).
26. Remove front drive shaft (LH/RH). Refer to [FAX-19, "Removal and Installation \(LH\)"](#) and [FAX-61, "Removal and Installation \(RH\)"](#).
27. Remove front exhaust tube. Refer to [EX-5, "Exploded View"](#).
28. Remove transfer assembly. Refer to [DLN-71, "Removal and Installation"](#).
29. Remove front suspension member. Refer to [FSU-22, "Removal and Installation"](#).
30. Remove CVT fluid cooler hoses from radiator. Refer to [CO-13, "Exploded View"](#).
31. Disconnect battery negative cable ground bolt from transaxle.
32. Remove upper torque rod (RH).
33. Remove engine mounting bracket (RH).
34. Install engine slingers into front left of engine mount bracket (RH) and rear right of cylinder head.

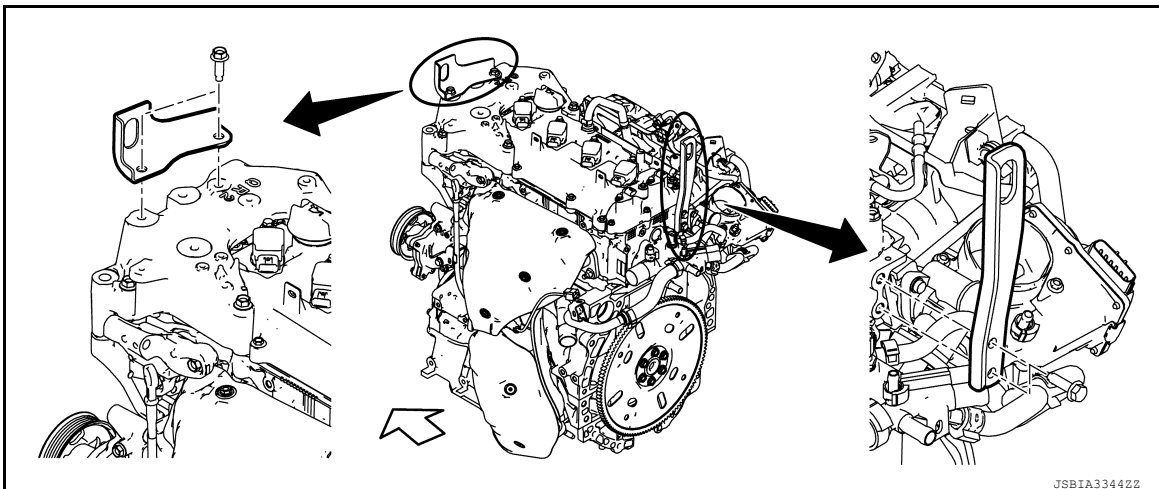

ENGINE ASSEMBLY

< UNIT REMOVAL AND INSTALLATION >

← : Engine front

Slinger bolts

Cylinder head side : 22.0 N·m (2.2 kg-m, 16 ft-lb)

Engine mount bracket side : 48.1 N·m (4.9 kg-m, 35 ft-lb)

35. Support weight of engine and transaxle assembly with a shop crane.
36. Use a suitable jack and securely support bottom of the engine and the transaxle assembly.

CAUTION:

Put a piece of wood or an equivalent as the supporting surface, secure a completely stable condition.

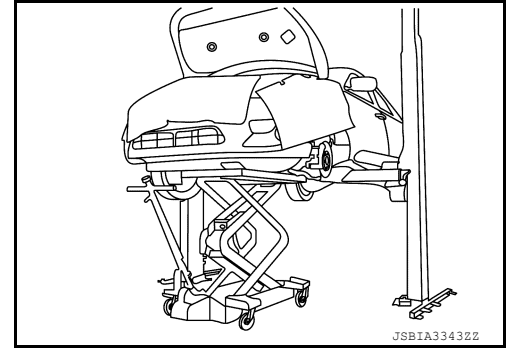

37. Slowly lower engine and transaxle assembly.

CAUTION:

- As engine and transaxle assembly is being lowered ensure there is no interference with body or engine harness connectors.
- Before and during this procedure, always check if any harnesses are left connected.
- Avoid any damage to, or any oil/grease smearing or spills onto the engine mounting insulators.

38. Disconnect harness connector from input speed sensor. Refer to [TM-207, "Removal and Installation"](#).
39. Disconnect harness connector from output speed sensor. Refer to [TM-209, "Removal and Installation"](#).
40. Disconnect harness connector from primary speed sensor. Refer to [TM-208, "Removal and Installation"](#).
41. Remove PNP switch from transaxle assembly.
42. Remove harness connector from transaxle assembly.
43. Remove starter motor. Refer to [STR-21, "Removal and Installation"](#).
44. Remove drive plate inspection cover from engine.
45. Hold drive plate with suitable tool and remove torque converter nuts.
46. Remove transaxle to engine mount bolts.

INSTALLATION

Installation is in the reverse order of removal.

NOTE:

- Tighten drive plate bolts to specification. Refer to [EM-97, "Exploded View"](#).
- Tighten the transmission bolts to specification. Refer to [TM-220, "Exploded View"](#).
- Do not allow oil to get on mounting insulators. Be careful not to damage mounting insulators.

1. Install the engine mount insulator (RH) as follows:
 - a. Temporarily tighten the bolts.
 - b. Tighten the bolts in sequence as shown to the specified torque.

← : Front

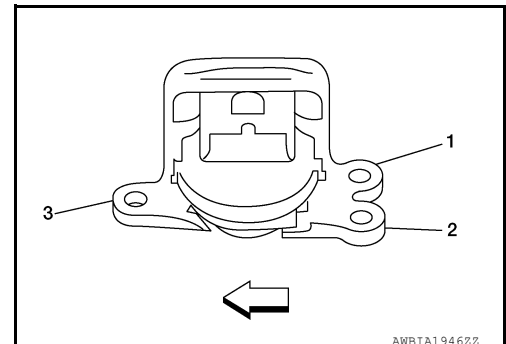

- c. Temporarily tighten the bolts.

NOTE:

ENGINE ASSEMBLY

< UNIT REMOVAL AND INSTALLATION >

Bolt is initially installed at position 1; Positions 2 - 5 are then tightened to specification.

- d. Tighten the bolts in sequence as shown to the specified torque.

↔ : Front

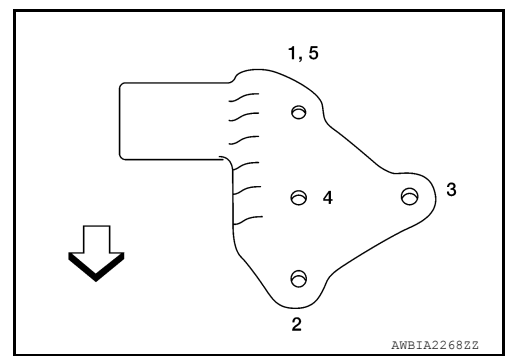

- 2. Install the engine mounting bracket (RH).

- a. Temporarily tighten the bolts.

NOTE:

Bolt is initially installed at position 1; Positions 2 - 5 are then tightened to specification.

- b. Tighten the bolts in sequence as shown to the specified torque.

↔ : Front

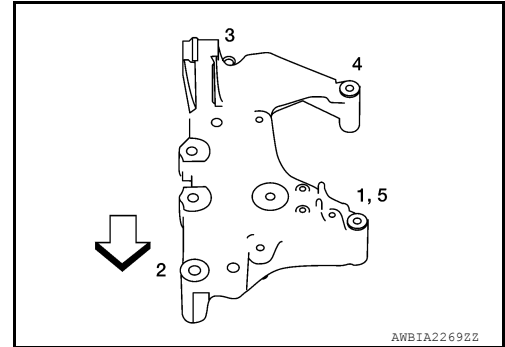

- 3. Install the upper torque rod (RH) as follows:

- a. Temporarily tighten bolts.

- b. Tighten the bolts in sequence as shown to the specified torque.

↔ : Front

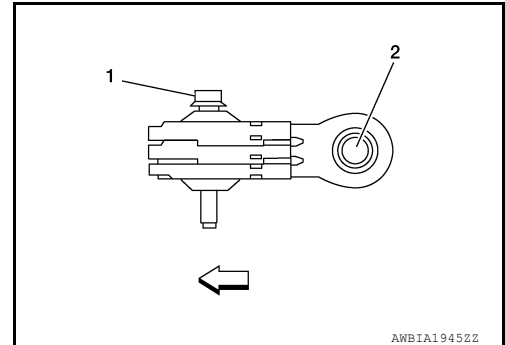

- 4. Install the lower torque rod bolts as follows:

- a. Temporarily tighten the bolts.

- b. Tighten the bolts in sequence as shown to the specified torque.

↔ : Front

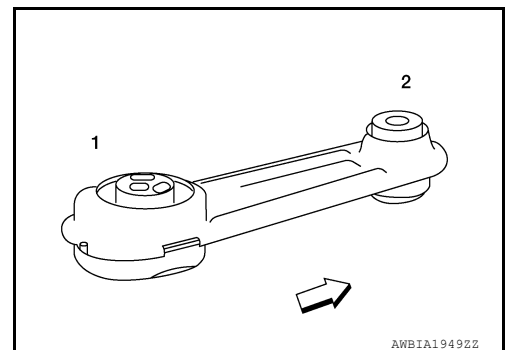

A
EM
C
D
E
F
G
H
I
J
K
L
M
N
O
P

ENGINE ASSEMBLY

< UNIT REMOVAL AND INSTALLATION >

5. Install the lower torque rod bracket bolts as follows:
 - a. Temporarily tighten the bolts.
 - b. Tighten the bolts in sequence as shown to the specified torque.

↶ : Front

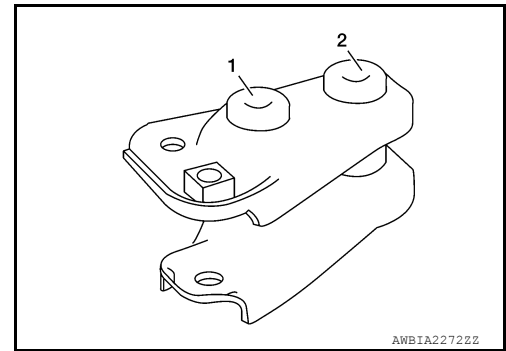

6. Install the engine mounting insulator (LH) as follows:
 - a. Temporarily tighten the bolts.

NOTE:

Bolts are initially installed at positions 1 and 2; Positions 3 - 6 are then tightened to specification.

- b. Tighten the bolts in sequence as shown to the specified torque.

↶ : Front

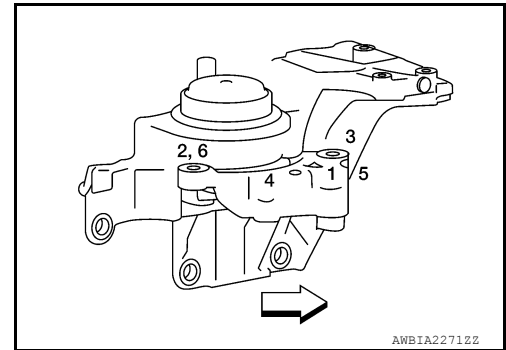

- c. Temporarily tighten the bolts.
 - d. Tighten the bolts in sequence as shown to the specified torque.

↶ : Front

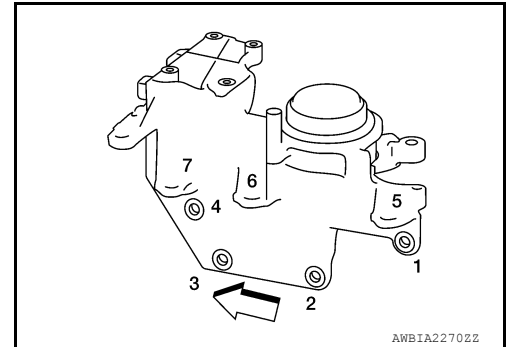

Inspection

INFOID:000000011279978

INSPECTION AFTER INSTALLATION

- Before starting engine, check oil/fluid levels including engine coolant and engine oil. If less than required quantity, fill to the specified level. Refer to [MA-11, "Fluids and Lubricants"](#).
- Use procedure below to check for fuel leaks.
- Turn ignition switch ON (with engine stopped). With fuel pressure applied to fuel piping, check for fuel leaks at connection points.
- Start engine. With engine speed increased, check again for fuel leaks at connection points.
- Run engine to check for unusual noise and vibration.

NOTE:

If hydraulic pressure inside timing chain tensioner drops after removal and installation, slack in the guide may generate a pounding noise during and just after engine start. However, this is normal. Noise will stop after hydraulic pressure rises.

- Warm up engine thoroughly to make sure there are no leaks of fuel, exhaust gas, or any oils/fluids including engine oil and engine coolant.
- Bleed air from passages in lines and hoses, such as in cooling system.
- After cooling down engine, again check oil/fluid levels including engine oil and engine coolant. Refill to specified level, if necessary.
- Summary of the inspection items:

ENGINE ASSEMBLY

< UNIT REMOVAL AND INSTALLATION >

Items	Before starting engine	Engine running	After engine stopped	
Engine coolant	Level	Leakage	Level	A
Engine oil	Level	Leakage	Level	EM
Transmission / transaxle fluid	AT & CVT Models Leakage	Level / Leakage	Leakage	EM
Other oils and fluids*	Level	Leakage	Level	C
Fuel	Leakage	Leakage	Leakage	D
Exhaust gases	—	Leakage	—	E

*: Power steering fluid, brake fluid, etc.

A
EM
C
D
E
F
G
H
I
J
K
L
M
N
O
P

ENGINE STAND SETTING

< UNIT DISASSEMBLY AND ASSEMBLY >

UNIT DISASSEMBLY AND ASSEMBLY

ENGINE STAND SETTING

Setting

INFOID:0000000011279979

NOTE:

Explained here is how to disassemble with engine stand supporting transaxle surface. When using a different type of engine stand, note difference in steps, etc.

1. Remove engine and transaxle assembly from vehicle, and separate transaxle from engine. Refer to [EM-86. "Exploded View"](#).
2. Install engine to engine stand with the following procedure:
 - a. Remove drive plate.
 - Secure drive plate (1) using suitable tool (A) and remove bolts using suitable tool.

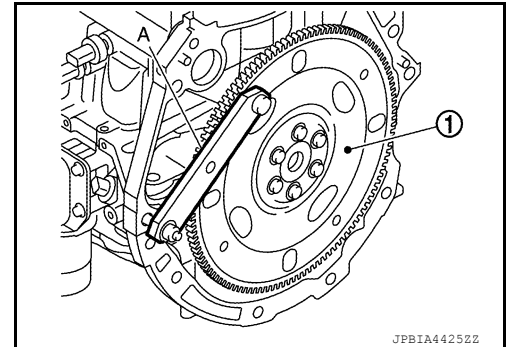

- b. Remove the reinforcement plate. Refer to [EM-97. "Exploded View"](#).
 - c. Remove pilot converter (1) from the rear end of the crankshaft. Use suitable tool (A), if necessary.

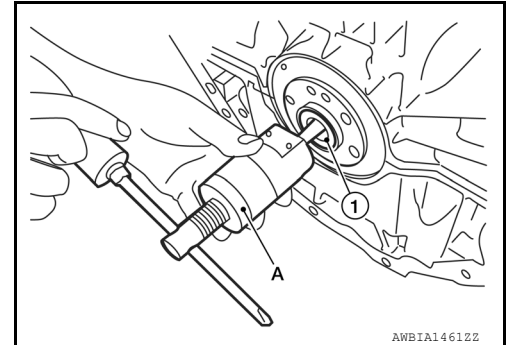

- d. Lift the engine with a hoist to install it onto widely used engine stand.

CAUTION:

- Use the engine stand that has a load capacity [approximately 135 kg (298 lb) or more] large enough for supporting the engine weight.
- If the load capacity of stand is not adequate, remove the following parts beforehand to reduce the potential risk of overturning stand.
 - Intake manifold: Refer to [EM-29. "Removal and Installation"](#).
 - Exhaust manifold: Refer to [EM-32. "Removal and Installation"](#).
 - Rocker cover: Refer to [EM-42. "Removal and Installation"](#).

NOTE:

The figure shows an example of widely used engine stand (A) that can support mating surface of transaxle with drive plate removed.

CAUTION:

Before removing the hanging chains, check the engine stand is stable and there is no risk of overturning.

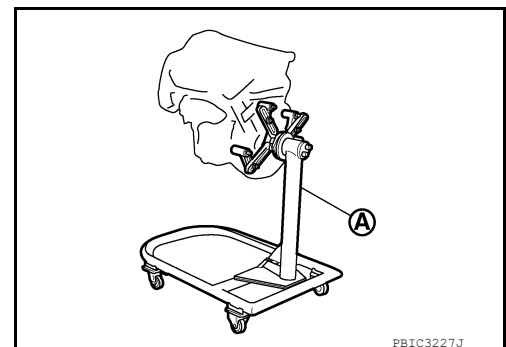

CYLINDER BLOCK

< UNIT DISASSEMBLY AND ASSEMBLY >

CYLINDER BLOCK

Exploded View

INFOID:000000011279980

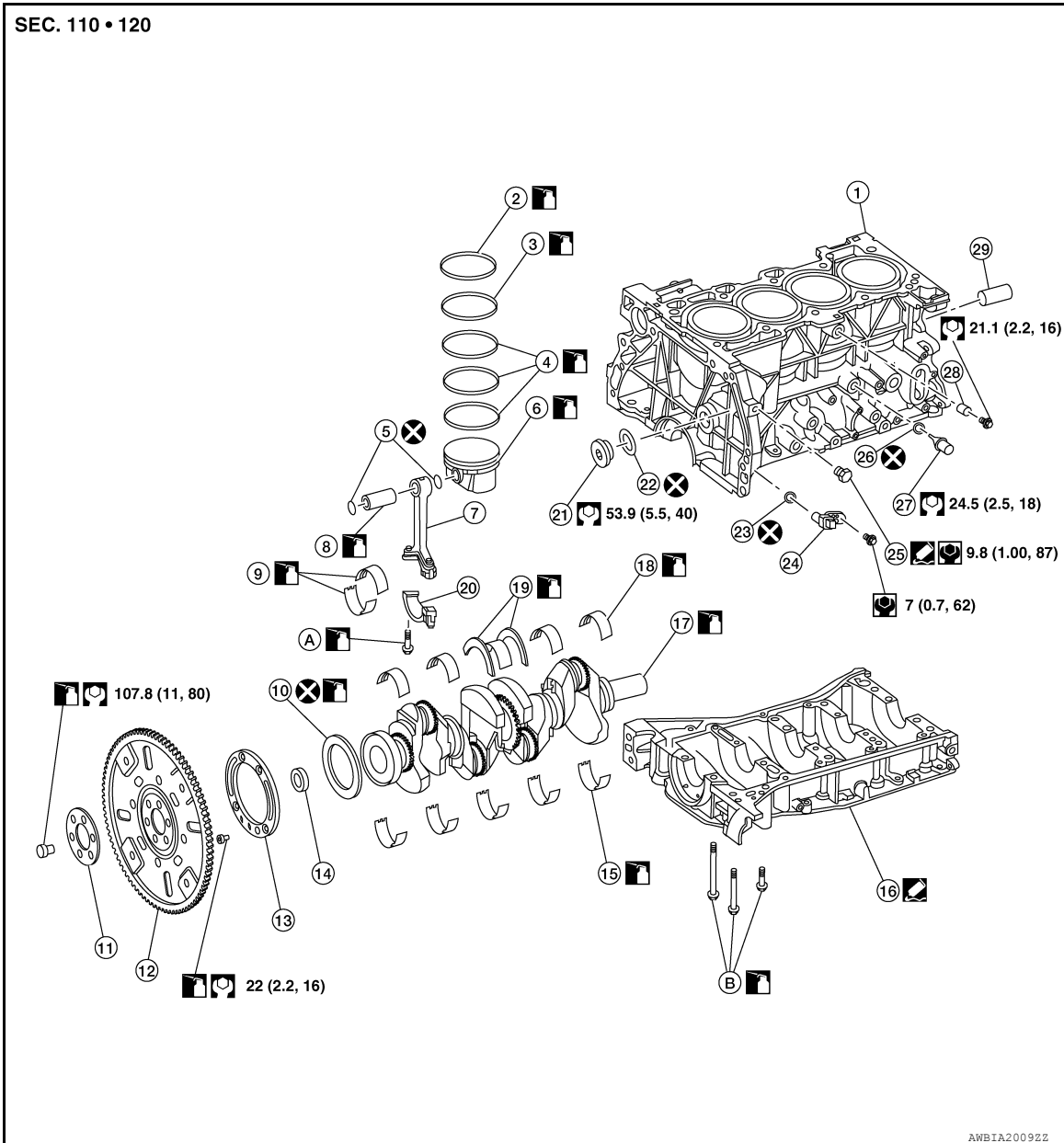

- | | | |
|--------------------------|---|--------------------------------|
| 1. Cylinder block | 2. Top ring | 3. Second ring |
| 4. Oil ring | 5. Snap ring | 6. Piston |
| 7. Connecting rod | 8. Piston pin | 9. Connecting rod bearing |
| 10. Rear oil seal | 11. Reinforcement plate | 12. Drive plate |
| 13. Signal plate | 14. Pilot converter | 15. Main bearing (lower) |
| 16. Lower cylinder block | 17. Crankshaft | 18. Main bearing (upper) |
| 19. Thrust bearing | 20. Connecting rod bearing cap | 21. Drain plug |
| 22. O-ring | 23. O-ring | 24. Crankshaft position sensor |
| 25. Drain plug | 26. O-ring | 27. Oil temperature sensor |
| 28. Knock sensor | 29. Cylinder block heater (if equipped) | A. Refer to INSTALLATION |
| B. Refer to INSTALLATION | | |

CYLINDER BLOCK

< UNIT DISASSEMBLY AND ASSEMBLY >

Disassembly and Assembly

INFOID:000000011279981

DISASSEMBLY

1. Mount the engine on a suitable engine stand. Refer to [EM-96, "Setting"](#).
2. Drain any remaining engine oil and engine coolant, (if necessary).
3. Remove drain plugs from cylinder block.
4. Remove cylinder block heater (if equipped).
5. Remove cylinder head. Refer to [EM-59, "Exploded View"](#).
6. Remove knock sensor.
CAUTION:
Carefully handle knock sensor avoiding shocks.
7. Remove crankshaft position sensor (POS) (2).

(1) : O-ring

⇐ : Engine front

CAUTION:

- Avoid impacts such as dropping.
- Do not disassemble.
- Keep crankshaft position sensor (POS) away from metal particles.
- Do not place crankshaft position sensor (POS) in a location where it is exposed to magnetism.

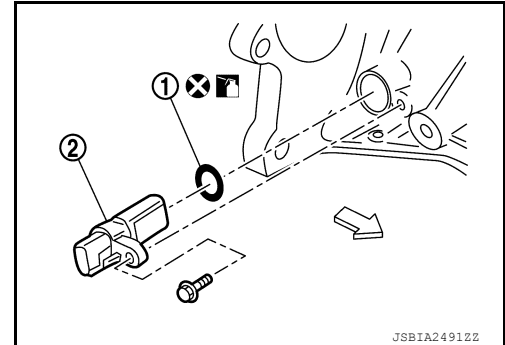

8. Remove oil temperature sensor.

CAUTION:

Do not reuse O-ring.

9. Remove piston and connecting rod assembly with the following procedure:
 - Before removing piston and connecting rod assembly, check the connecting rod side clearance. Refer to [EM-105, "Inspection"](#).
- a. Position crankshaft pin corresponding to connecting rod to be removed onto the bottom dead center.
- b. Remove connecting rod cap. Number connecting rod caps so they can be assembled in the same position and direction.
- c. Using a hammer handle or similar tool, push piston and connecting rod assembly out to cylinder head side.

CAUTION:

- Do not damage matching surface with connecting rod cap.
- Do not damage cylinder wall and crankshaft pin, resulting from an interference of the connecting rod big end.

NOTE:

Number the pistons and rods so they can be installed in the same position.

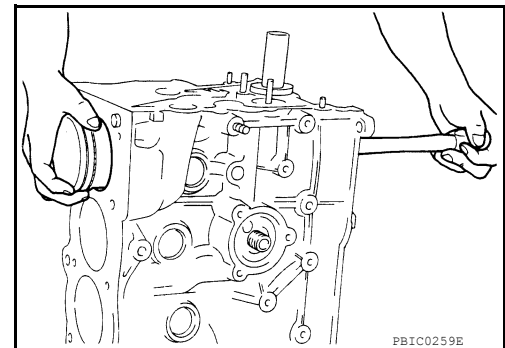

10. Remove connecting rod bearings.

CAUTION:

When removing them note the installation position. Keep them in the correct order.

11. Remove piston rings from piston.
 - Before removing piston rings check the piston ring side clearance. Refer to [EM-105, "Inspection"](#).

CYLINDER BLOCK

< UNIT DISASSEMBLY AND ASSEMBLY >

- Remove piston rings using suitable tool (A).

CAUTION:

- When removing piston rings, be careful not to damage the piston.
- Do not damage piston rings by expanding them excessively.

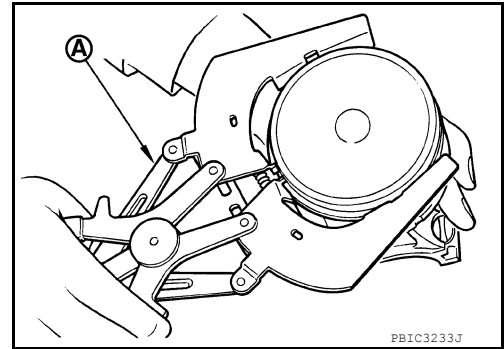

12. Remove piston from connecting rod using the following procedure:

- a. Remove snap rings using snap ring pliers (A).

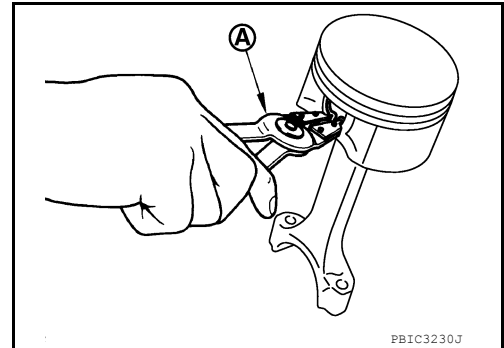

- b. Heat piston to 60°C to 70°C (140°F to 158°F) with a heat gun (A).

CAUTION:

- Avoid directly touching piston.
- Piston contains heat, when working, wear protective equipment to avoid getting burned.

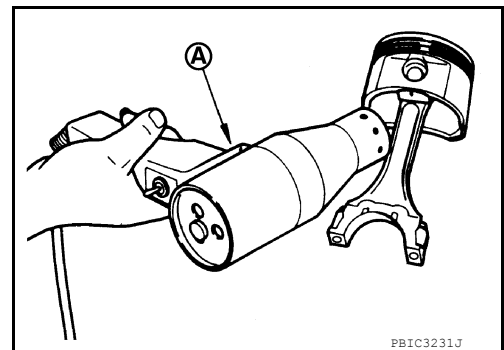

- c. Push out piston pin using a suitable tool.

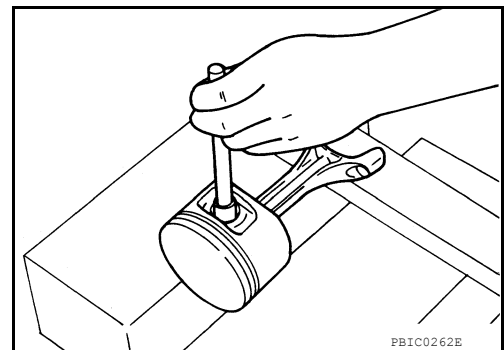

13. Remove lower cylinder block using the following procedure:

- Measure crankshaft end play before loosening lower cylinder block bolts. Refer to [EM-105, "Inspection"](#).

A
EM
C
D
E
F
G
H
I
J
K
L
M
N
O
P

CYLINDER BLOCK

< UNIT DISASSEMBLY AND ASSEMBLY >

- a. Loosen and remove lower cylinder block bolts in reverse order as shown.

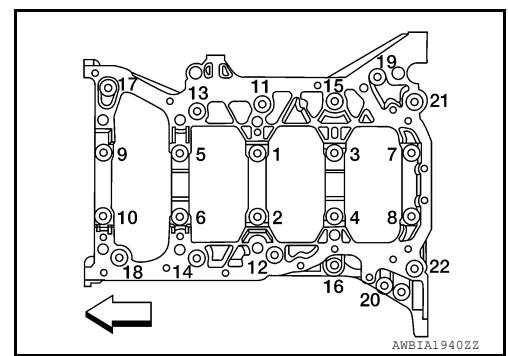

- b. Remove the lower cylinder block using Tool (A).

CAUTION:

Be careful not to damage the mating surfaces.

NOTE:

In areas where the cutter is difficult to use, use a plastic hammer to lightly tap (1) the cutter where the liquid gasket is applied. Use a plastic hammer to slide (2) the cutter by tapping on the side.

Tool number : KV10111100 (J-37228)

- c. Remove the lower cylinder block while tapping lightly with a plastic hammer.

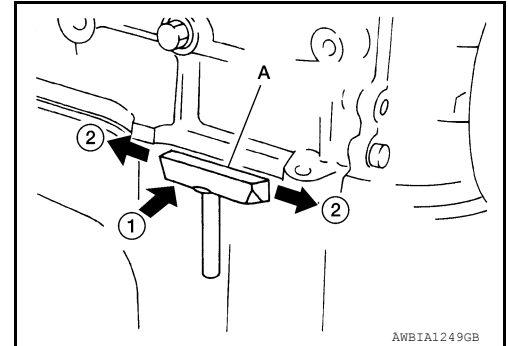

14. Remove crankshaft (2).

CAUTION:

- Do not damage or deform signal plate (1) mounted on crankshaft.
- When setting crankshaft on a flat floor surface, use a block of wood to avoid contact between signal plate and floor surface.
- Do not remove signal plate unless it is necessary.

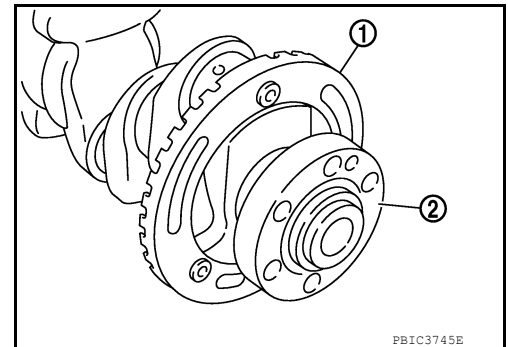

15. Remove rear oil seal from rear end of crankshaft.

CAUTION:

Do not damage the crankshaft or cylinder block when removing the rear main seal.

16. Remove main bearing (upper and lower) and thrust bearings from cylinder block and lower cylinder block.

CAUTION:

When removing bearings note the installation position. Keep them in the correct order.

NOTE:

When removing the rear oil seal without removing the cylinder block, use a suitable tool to pull it out between the crankshaft and block.

17. Remove oil jets (1) from cylinder block.

CAUTION:

When removing oil jet assemblies note the installation position. Keep them in the correct order.

⇐ **Engine front**

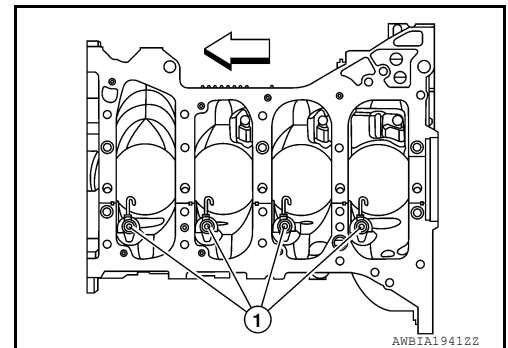

ASSEMBLY

CYLINDER BLOCK

< UNIT DISASSEMBLY AND ASSEMBLY >

1. Fully air-blow engine coolant and engine oil passages in cylinder block, cylinder bore and crankcase to remove any foreign material.

CAUTION:

Use goggles to protect your eyes.

2. Install drain plugs to cylinder block as shown.

CAUTION:

Do not reuse washer (1).

- Apply liquid gasket to the threads of drain plug (3).

Use Genuine RTV Silicone Sealant or equivalent. Refer to [GI-22, "Recommended Chemical Products and Sealants"](#).

NOTE:

Do not apply liquid gasket to the thread of plug (2).

← **Engine front**

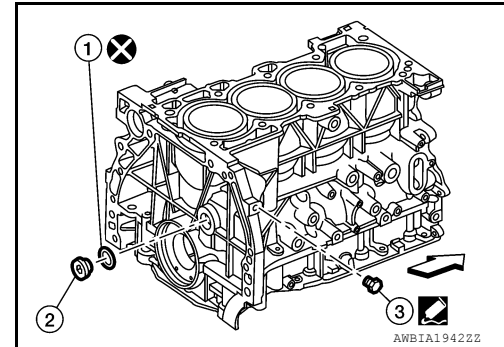

- Tighten each plug as specified below.

Part	Washer	Tightening torque
2	Yes	53.9 N·m (5.5 kg-m, 40 ft-lb)
3	No	9.8 N·m (1.00 kg-m, 17 in-lb)

3. Install oil jets (1).

Oil jets (1) : 23 N·m (2.3 kg-m, 17 ft-lb)

← **Engine front**

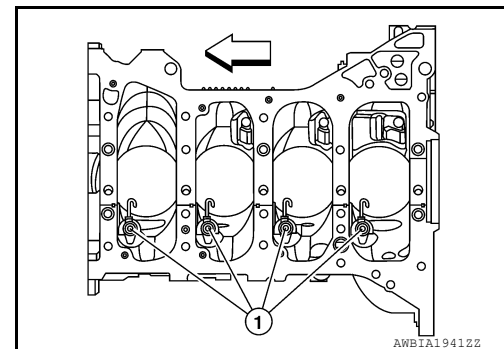

4. Install main bearings and thrust bearings using following procedure:

- a. Remove dust, dirt, and engine oil on the bearing mating surfaces of cylinder block and lower cylinder block.
- b. Install thrust bearings (1) to both sides of the No. 3 journal (A) housing on cylinder block.
 - Install thrust bearings with the oil groove (B) facing crankshaft arm (outside).

← **Engine front**

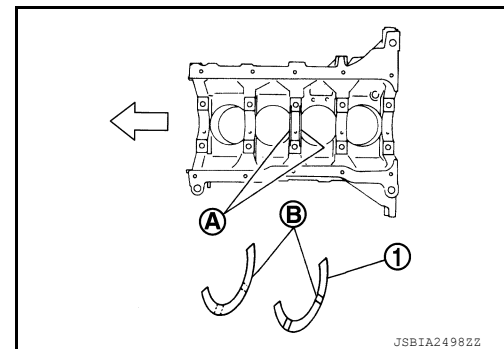

- c. Install the main bearings paying attention to the direction.

- Main bearing with an oil hole and groove (E) goes on cylinder block. The one without them (C) goes on lower cylinder block.

CYLINDER BLOCK

< UNIT DISASSEMBLY AND ASSEMBLY >

- Only main bearing (on cylinder block) for No. 3 journal (2) has different specifications.

- (1) : Journal other than no. 3
- (D) : Thrust bearings

- Before installing main bearings, apply new engine oil to the bearing surface (inside). Do not apply engine oil to the back surface, but thoroughly clean it.
- When installing, align main bearing stopper (B) to the notch.
- Ensure the oil holes (A) on cylinder block and those on the corresponding bearing are aligned.

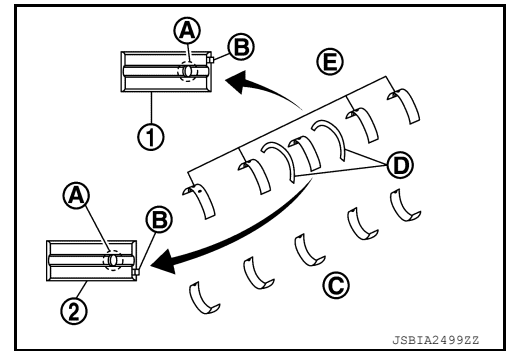

JSBIA2499ZZ

5. Install signal plate to crankshaft (if removed).

- a. Set the signal plate with flange facing toward the counterweight side (engine front side).
- b. After positioning crankshaft (2) and signal plate (1) with positioning dowl pin (A), tighten bolts.

- (1) : Signal plate
- (2) : Crankshaft
- (A) : Dowel pin (used to position the signal plate)

- c. Remove dowel pin.

CAUTION:

Be sure to remove dowel pin.

6. Install crankshaft to cylinder block.

- While turning crankshaft by hand, check that it turns smoothly.

CAUTION:

Do not install rear oil seal yet.

7. Install lower cylinder block with the following procedure:

- a. Apply liquid gasket with a suitable tool to lower cylinder block. **Use Genuine RTV Silicone Sealant or equivalent. Refer to [GI-22, "Recommended Chemical Products and Sealants"](#).**

- (B) : Apply liquid gasket to an end
- (a) : 4.0 - 5.0 mm (0.157 - 0.197 in)

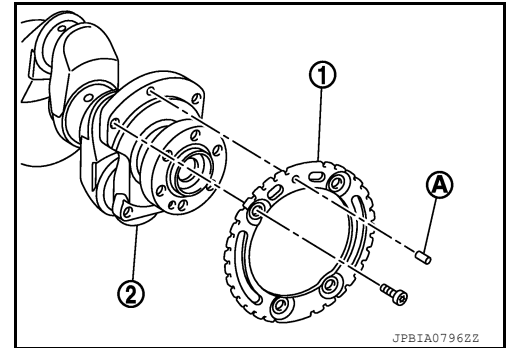

JPBIA0796ZZ

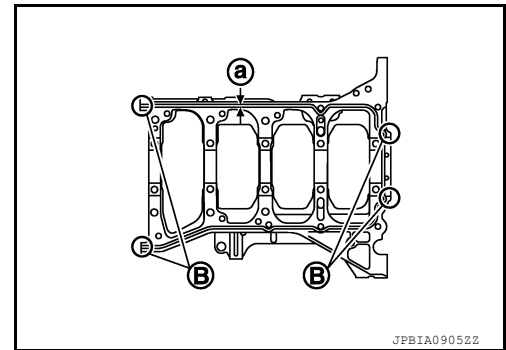

JPBIA0905ZZ

NOTE:

Lower cylinder block cannot be replaced as a single part because it is machined together with cylinder block.

- b. Apply new engine oil to threads and seat surfaces of the bolts.
- c. Tighten lower cylinder block bolts to specification in the numerical order as shown.

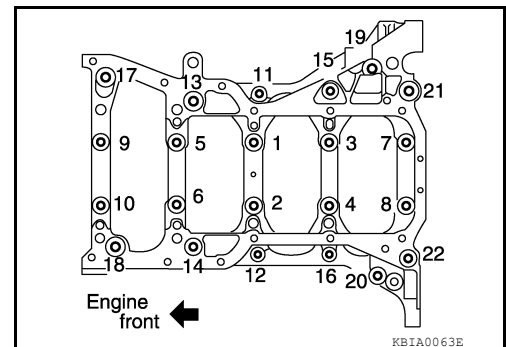

KBIA0063E

CYLINDER BLOCK

< UNIT DISASSEMBLY AND ASSEMBLY >

- d. Tighten bolts to specification using suitable tool and Tool (A).

CAUTION:

Check rotation angle. Do not judge angle by visual inspection.

Step 1, bolts 11 - 22 only : 25.1 N·m (2.6 kg-m, 19 ft-lb)

Step 2, bolts 1 - 10 only : 39.2 N·m (4.0 kg-m, 29 ft-lb)

Step 3, bolts 1 - 10 only : 60°degrees rotation

Tool number (A) : KV10112100 (BT-8653-A)

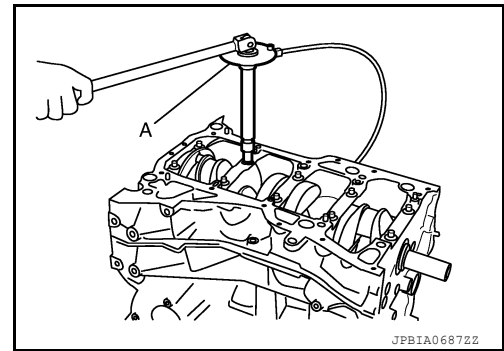

NOTE:

Torque and rotation angle should be within tolerance.

Torque : Within 2.9 N·m (0.30 kg-m, 26 in-lb)

Rotation angle : Within 5° degrees rotation

- e. Install rear oil seal. Refer to [EM-84, "REAR OIL SEAL : Removal and Installation"](#).

- After installing bolts, check that crankshaft can be rotated smoothly by hand.
- Wipe off completely any protruding liquid gasket on front side of engine.
- Check crankshaft end play. Refer to [EM-105, "Inspection"](#).

8. Install piston to connecting rod with the following procedure:

- a. Install new snap ring to the groove of the piston rear side using snap ring pliers.
- Insert it fully into groove to install.

CAUTION:

Do not reuse snap rings.

- b. Assemble piston to connecting rod.

- Using a heat gun (A), heat piston until piston pin can be pushed in by hand without excess force [approximately 60°C to 70°C (140°F to 158°F)]. From the front to the rear, insert piston pin into piston and connecting rod.

CAUTION:

- **Avoid directly touching piston.**
- **Piston contains heat, when working, wear protective equipment to avoid getting burned.**

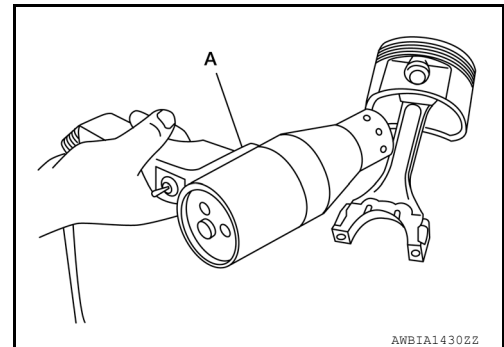

- Set so that the front mark (A) on the piston head, the oil splash (B) and the cylinder number (C) on connecting rod are positioned as shown.

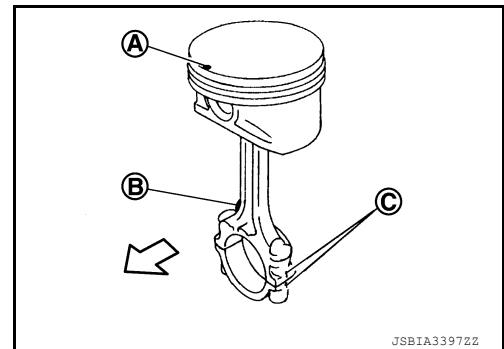

- c. Install new snap ring to the groove of the piston front side.
- Insert it fully into groove to install.
 - After installing, check that connecting rod moves smoothly.

CYLINDER BLOCK

< UNIT DISASSEMBLY AND ASSEMBLY >

9. Install piston rings using suitable tool.
- Position each ring with the gap as shown referring to the piston front mark (B).

- (A) : Oil ring upper or lower rail gap (either of them)
- (C) : Second ring and oil ring spacer gap
- (D) : Top ring gap

- Install second ring with the stamped surface (E) facing upward.

CAUTION:

- Do not damage piston.
- Do not damage piston rings by expanding them excessively.
- Do not contact rail end gap under oil ring with oil drain cast groove of piston.

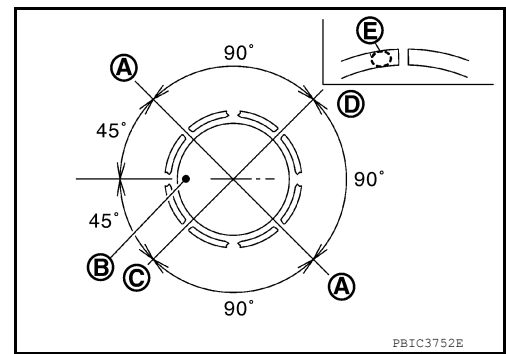

10. Install connecting rod bearings to connecting rod and connecting rod cap.

- When installing connecting rod bearings apply new engine oil to the bearing surface (inside). Do not apply engine oil to the back surface, but thoroughly clean it.
- When installing, align the connecting rod bearing stopper protrusion (A) with the cutout (B) of connecting rod and connecting rod cap to install.
- Ensure the oil hole on connecting rod and that on the corresponding bearing are aligned.

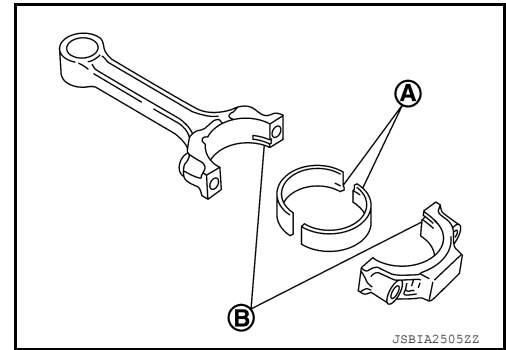

11. Install piston (A) and connecting rod assembly to crankshaft.

- Position crankshaft pin corresponding to connecting rod to be installed onto the bottom dead center.
- Apply new engine oil sufficiently to the cylinder bore, piston and crankshaft pin.
- Match the cylinder position with the cylinder number on connecting rod to install.
- Using a suitable tool, install piston with the front mark on the piston head facing the front of the engine.

CAUTION:

Be careful not to damage the cylinder wall and crankshaft pin, resulting from an interference of the connecting rod big end.

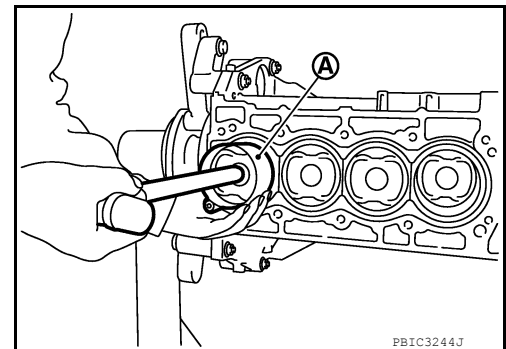

12. Install connecting rod cap.

- Match the stamped cylinder number marks on connecting rod with those on connecting rod cap to install.

- (A) : Oil splash
- (B) : Small end diameter grade
- (C) : Production control number
- (D) : Bearing stopper groove
- (E) : Production control number
- (F) : Cylinder number
- (G) : Big end diameter grade

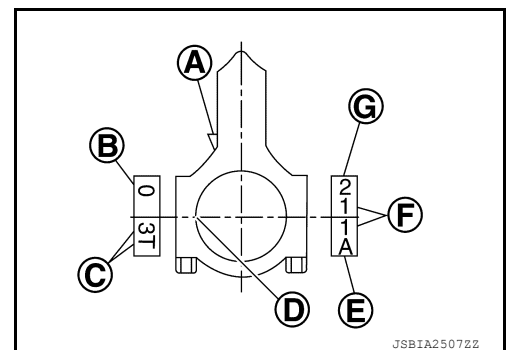

13. Tighten connecting rod bolt with the following procedure:

CYLINDER BLOCK

< UNIT DISASSEMBLY AND ASSEMBLY >

- a. Tighten the connecting rod bolts using Tool (A) as follows:
Apply engine oil to the threads and seats of the connecting rod bolts.

CAUTION:

Check tightening angle. Do not judge angle by visual inspection.

- Step 1 : 27.4 N·m (2.8 kg-m, 20 ft-lb)**
Step 2 : 0 N·m
Step 3 : 19.6 N·m (2.0 kg-m, 14 lb-ft)
Step 4 : Rotate bolts 90° + 0.5°

Tool number : KV10112100 (BT-8653-A)

- After tightening connecting rod bolts, check that crankshaft rotates smoothly.
- Check the connecting rod side clearance. Refer to [EM-105. "Inspection"](#).

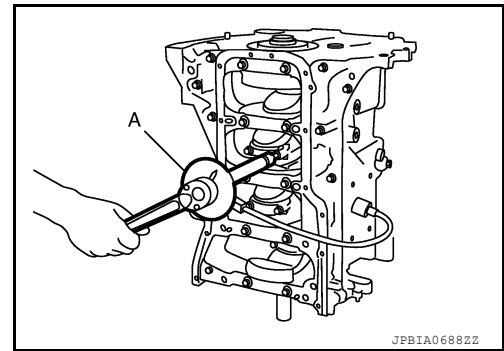

14. Install knock sensor (1).

- Install knock sensor with connector facing 180° +/- 15° (a) as shown.

CAUTION:

- **Do not tighten bolts while holding connector.**
- **If any impact by dropping is applied to knock sensor, replace it with a new one.**

NOTE:

- Check that there is no foreign material on the cylinder block mating surface and the back surface of knock sensor.
- Check that knock sensor does not interfere with other parts.

15. Install crankshaft position sensor (POS).

16. Assembly of remaining components is in the reverse order of disassembly.

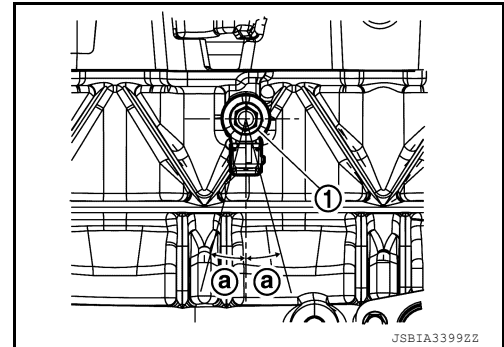

Inspection

INFOID:0000000011279982

CRANKSHAFT END PLAY

- Measure clearance between thrust bearings and crankshaft arm when crankshaft is moved fully forward or backward using suitable tool (A).

Standard and Limit : Refer to [EM-125. "Cylinder Block"](#).

- If measured value exceeds limit replace thrust bearings and measure again. If it still exceeds limit replace crankshaft.

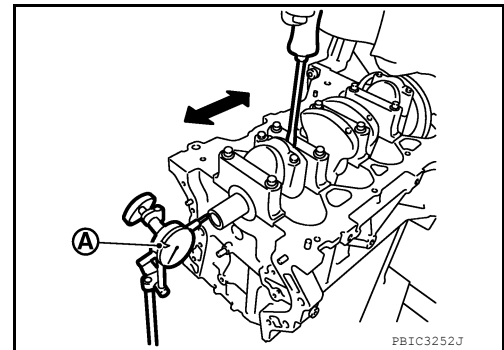

CONNECTING ROD SIDE CLEARANCE

- Measure side clearance between connecting rod and crankshaft arm using suitable tool (A).

Standard and Limit : Refer to [EM-125. "Cylinder Block"](#).

- If measured value exceeds limit replace connecting rod and measure again. If it still exceeds limit replace crankshaft.

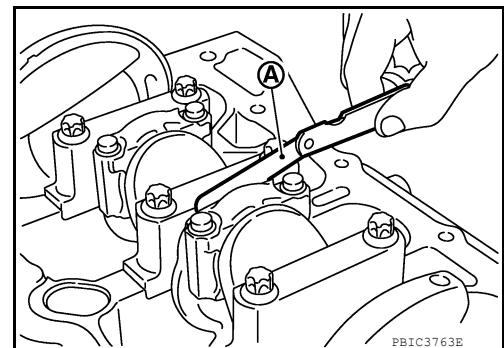

A
EM
C
D
E
F
G
H
I
J
K
L
M
N
O
P

CYLINDER BLOCK

< UNIT DISASSEMBLY AND ASSEMBLY >

PISTON TO PISTON PIN OIL CLEARANCE

Piston Pin Hole Diameter

- Measure inner diameter of piston pin hole using suitable tool (A).

Standard : Refer to [EM-125, "Cylinder Block"](#).

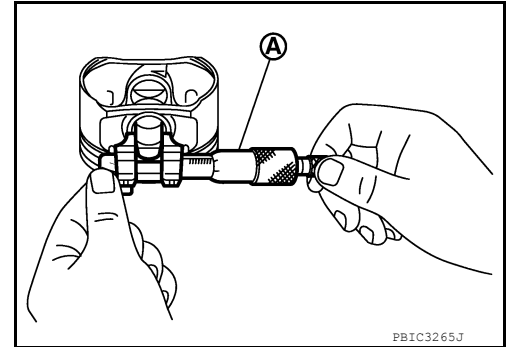

Piston Pin Outer Diameter

- Measure outer diameter of piston pin using suitable tool (A).

Standard : Refer to [EM-125, "Cylinder Block"](#).

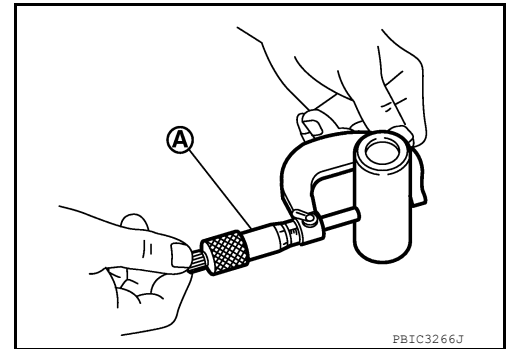

Piston to Piston Pin Oil Clearance

- $(\text{Piston to piston pin oil clearance}) = (\text{Piston pin hole diameter}) - (\text{Piston pin outer diameter})$

Standard : Refer to [EM-125, "Cylinder Block"](#).

- If oil clearance value exceeds the limit replace piston and piston pin assembly.

NOTE:

Piston is available together with piston pin as assembly.

PISTON RING SIDE CLEARANCE

- Measure side clearance of piston ring and piston ring groove using suitable tool (A).

Standard and Limit : Refer to [EM-125, "Cylinder Block"](#).

- If measured value exceeds limit replace piston ring and measure again. If value still exceeds the limit replace piston.

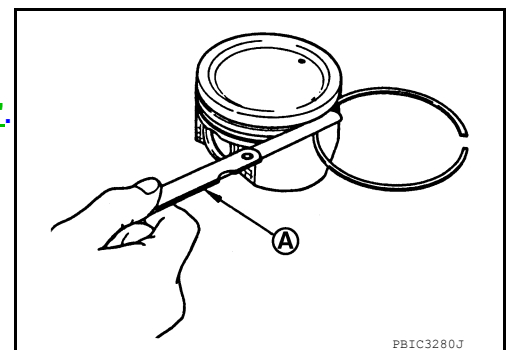

CONNECTING ROD BEND AND TORSION

CYLINDER BLOCK

< UNIT DISASSEMBLY AND ASSEMBLY >

- Check with a connecting rod aligner.

- (A) : Bend
- (B) : Torsion
- (C) : Feeler gauge

Limit : Refer to [EM-125, "Cylinder Block"](#).

- If measured value exceeds limit replace connecting rod assembly.

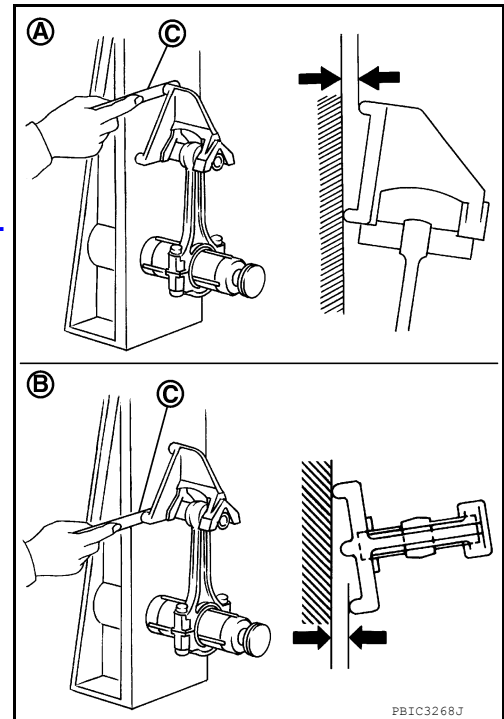

CONNECTING ROD BIG END DIAMETER

- Install connecting rod cap (1) without connecting rod bearing installed and tighten connecting rod bolts. Refer to [EM-98, "Disassembly and Assembly"](#).

- (2) : Connecting rod
- (A) : Example
- (B) : Measuring direction of inner diameter

- Measure inner diameter of connecting rod big end using suitable tool.

Standard : Refer to [EM-125, "Cylinder Block"](#).

- If measured value exceeds standard replace connecting rod assembly.

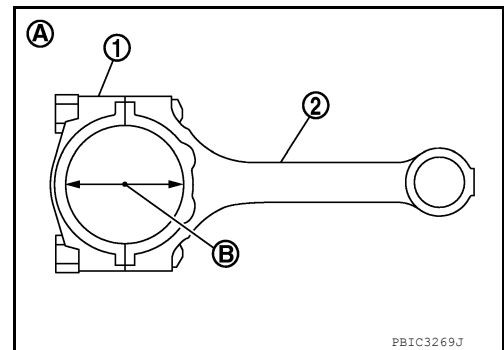

CONNECTING ROD BUSHING OIL CLEARANCE

Connecting Rod Bushing Inner Diameter

- Measure inner diameter of connecting rod bushing using suitable tool (A).

Standard : Refer to [EM-125, "Cylinder Block"](#).

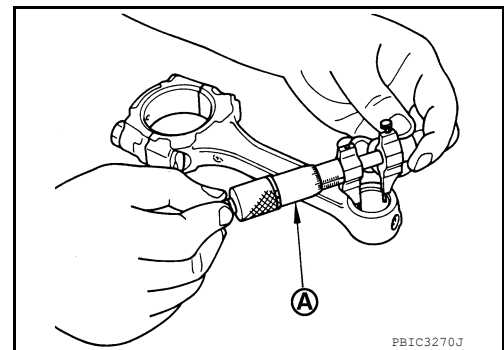

Piston Pin Outer Diameter

CYLINDER BLOCK

< UNIT DISASSEMBLY AND ASSEMBLY >

- Measure outer diameter of piston pin using suitable tool (A).

Standard : Refer to [EM-125, "Cylinder Block"](#).

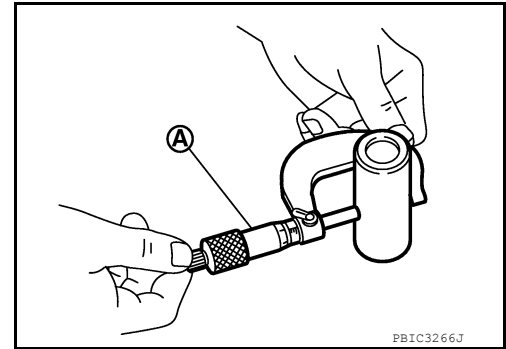

Connecting Rod Bushing Oil Clearance

- (Connecting rod bushing oil clearance) = (Connecting rod bushing inner diameter) - (Piston pin outer diameter)

Standard : Refer to [EM-125, "Cylinder Block"](#).

- If measured value exceeds standard replace connecting rod assembly and/or piston and piston pin assembly.

CYLINDER BLOCK TOP SURFACE DISTORTION

- Remove gasket on the cylinder block surface and also remove engine oil, scale, carbon and other contamination using suitable tool.

CAUTION:

Do not allow gasket flakes to enter engine oil or engine coolant passages.

- Measure distortion on cylinder block upper face at some different points in six directions using suitable tools (A/B).

Limit : Refer to [EM-125, "Cylinder Block"](#).

- If measured value exceeds standard replace cylinder block.

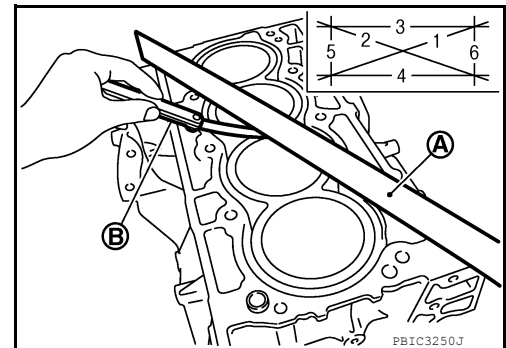

MAIN BEARING HOUSING INNER DIAMETER

- Install lower cylinder block without main bearings installed and tighten lower cylinder block bolts. Refer to [EM-98, "Disassembly and Assembly"](#).
- Measure inner diameter of main bearing housing using suitable tool.

Standard : Refer to [EM-125, "Cylinder Block"](#).

- If measured value exceeds standard replace cylinder block (1) and lower cylinder block (2) assembly.

NOTE:

Lower cylinder block cannot be replaced as a single unit because it is machined together with cylinder block.

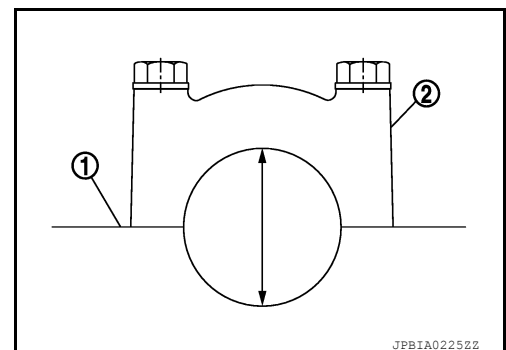

PISTON TO CYLINDER BORE CLEARANCE

Cylinder Bore Inner Diameter

- Measure cylinder bore for wear, out-of-round and taper at six different points on each cylinder using suitable tool. [(A) and (B) directions at (C), (D), and (E)] [(A) is in longitudinal direction of engine]

CYLINDER BLOCK

< UNIT DISASSEMBLY AND ASSEMBLY >

- (f) : 10 mm (0.39 in)
- (g) : 75 mm (2.95 in)
- (h) : 140 mm (5.51 in)

NOTE:

When determining cylinder bore grade, measure the cylinder bore at (B) position.

Standard:

Cylinder bore inner diameter

: Refer to [EM-125, "Cylinder Block"](#).

Limit:

Out-of-round [Difference between (A) and (B)]

Taper [Difference between (C) and (D)]

: Refer to [EM-125, "Cylinder Block"](#).

- If measured value exceeds limit or if there are scratches and/or seizure on the cylinder inner wall hone or re-bore the cylinder inner wall.

Piston Skirt Diameter

- Measure outer diameter of piston skirt with suitable tool (A).

Standard : Refer to [EM-125, "Cylinder Block"](#).

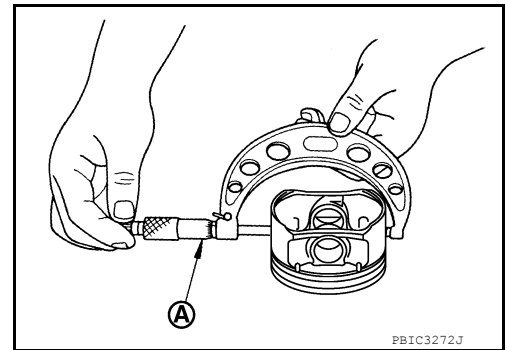
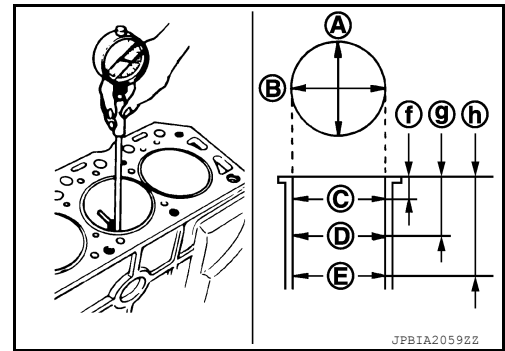

Piston to Cylinder Bore Clearance

- (Piston to cylinder bore clearance) = (Cylinder bore inner diameter) - (Piston skirt diameter)

Standard and Limit : Refer to [EM-125, "Cylinder Block"](#).

- If measured value exceeds limit replace piston and piston pin assembly..

PISTON RING END GAP

- Check that cylinder bore inner diameter is within standards.
- Lubricate with new engine oil to piston (1) and piston ring (2), and then insert (A) piston ring to middle of cylinder (B) with piston and measure piston ring end gap using suitable tool (C).

Standard and Limit : Refer to [EM-125, "Cylinder Block"](#).

- If measured value exceeds limit replace piston ring and measure again. If it still exceeds the limit replace cylinder block.

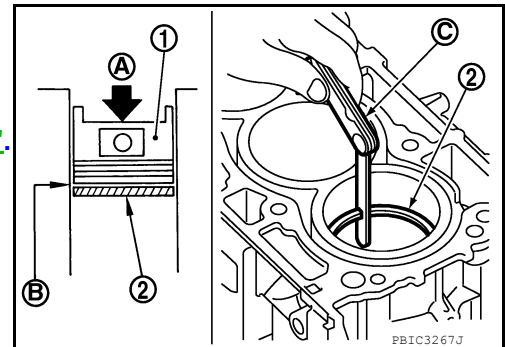

CRANKSHAFT MAIN JOURNAL DIAMETER

CYLINDER BLOCK

< UNIT DISASSEMBLY AND ASSEMBLY >

- Measure outer diameter of crankshaft main journals using suitable tool (A).

Standard : Refer to [EM-125, "Cylinder Block"](#).

- If measured value exceeds limit measure the main bearing oil clearance and use undersize bearing.

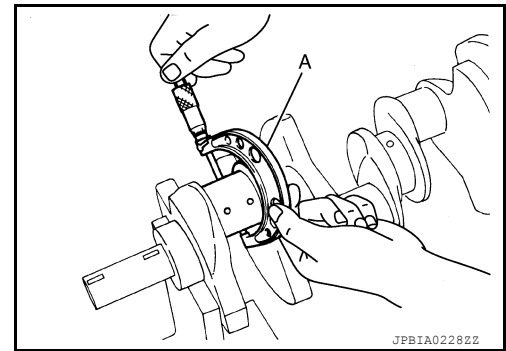

CRANKSHAFT PIN JOURNAL DIAMETER

- Measure outer diameter of crankshaft pin journal using suitable tool.

Standard : Refer to [EM-125, "Cylinder Block"](#).

- If measured value exceeds limit measure connecting rod bearing oil clearance and use undersize bearing.

OUT-OF-ROUND AND TAPER OF CRANKSHAFT

- Measure dimensions at four different points as shown on each main journal and pin journal using suitable tool.
- Out-of-round is indicated by the difference in dimension between (a) and (b) at (c) and (d).
- Taper is indicated by difference in dimension between (c) and (d) at (a) and (b).

Limit:

Out-of-round [Difference between (a) and (b)]

Taper [Difference between (c) and (d)]

: Refer to [EM-125, "Cylinder Block"](#).

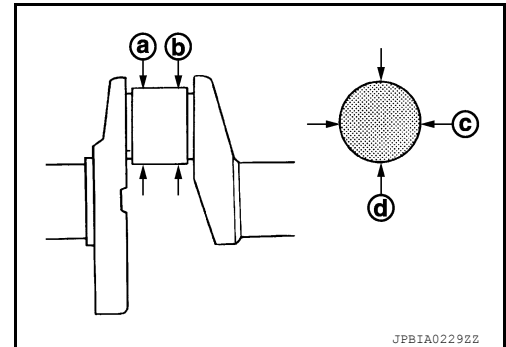

- If measured value exceeds limit correct or replace crankshaft.
- If corrected, measure bearing oil clearance of corrected main journal and/or pin journal. Then select main bearing and/or connecting rod bearing.

CRANKSHAFT RUNOUT

- Place V-block on precise flat table to support the journals on both ends of crankshaft.
- Place suitable tool (A) straight up on No. 3 journal.
- While rotating crankshaft, read movement of pointer on suitable tool. (Total indicator reading)

Limit : Refer to [EM-125, "Cylinder Block"](#).

- If measured value exceeds limit replace crankshaft.

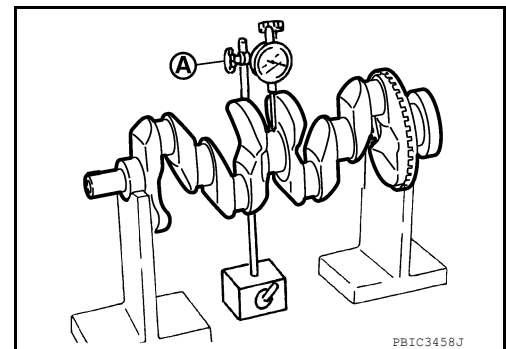

CONNECTING ROD BEARING OIL CLEARANCE

Method by Calculation

CYLINDER BLOCK

< UNIT DISASSEMBLY AND ASSEMBLY >

- Install connecting rod bearings (2) to connecting rod (3) and connecting rod bearings cap (1) and tighten connecting rod bolts. Refer to [EM-98, "Disassembly and Assembly"](#).

(A) : Example

- Measure inner diameter (B) of connecting rod bearing using suitable tool.
- (Bearing oil clearance) = (Connecting rod bearing inner diameter) - (Crankshaft pin journal diameter)

Standard and Limit : Refer to [EM-130, "Connecting Rod Bearing"](#).

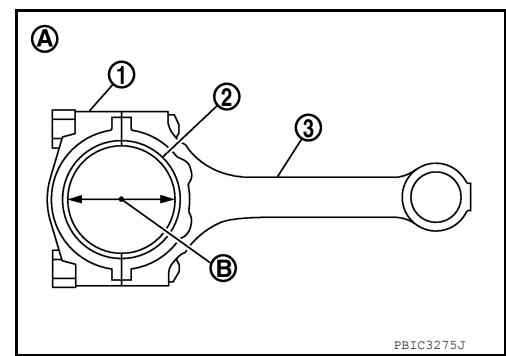

- If measured value exceeds limit select proper connecting rod bearing. Use connecting rod big end diameter and crankshaft pin journal diameter to obtain specified bearing oil clearance.

Method by Using Plastigage

- Remove engine oil and dust on crankshaft pin and the surfaces of each bearing completely.
- Cut plastigage slightly shorter than bearing width and place it in crankshaft axial direction avoiding oil holes.
- Install connecting rod bearings to connecting rod and cap and tighten connecting rod bolts. Refer to [EM-98, "Disassembly and Assembly"](#).

CAUTION:

Do not rotate crankshaft.

- Remove connecting rod cap and bearing and using the scale (A) on the plastigage bag measure the plastigage width.

NOTE:

The procedure when the measured value exceeds the limit is same as that described in the "Method by Calculation".

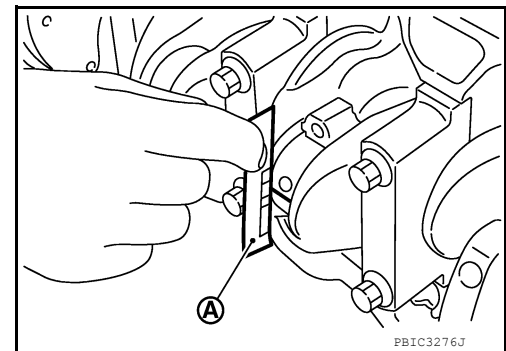

MAIN BEARING OIL CLEARANCE

Method by Calculation

- Install main bearings (3) to cylinder block (1) and lower cylinder block (2) and tighten lower cylinder block bolts. Refer to [EM-98, "Disassembly and Assembly"](#).

(A) : Example

- Measure the inner diameter (B) of main bearing with bore gauge.
- (Bearing oil clearance) = (Main bearing inner diameter) - (Crankshaft main journal diameter)

Standard and Limit : Refer to [EM-128, "Main Bearing"](#).

- If measured value exceeds limit select proper main bearing. Use main bearing inner diameter and crankshaft main journal diameter to obtain specified bearing oil clearance. Refer to [EM-98, "Disassembly and Assembly"](#).

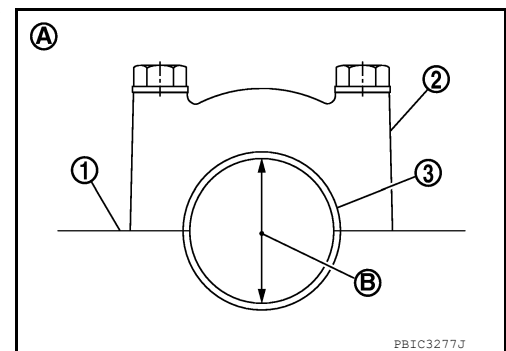

Method by Using Plastigage

- Remove engine oil and dust on crankshaft main journal and surfaces of each bearing completely.
- Cut plastigage slightly shorter than bearing width and place it in crankshaft axial direction avoiding oil holes.
- Install main bearings on cylinder block and lower cylinder block and tighten lower cylinder block bolts. Refer to [EM-98, "Disassembly and Assembly"](#).

CAUTION:

Do not rotate crankshaft.

CYLINDER BLOCK

< UNIT DISASSEMBLY AND ASSEMBLY >

- Remove lower cylinder block and bearings and using the scale (A) on the plastigage bag measure the plastigage width.

NOTE:

The procedure when measured value exceeds the limit is same as that described in "Method by Calculation".

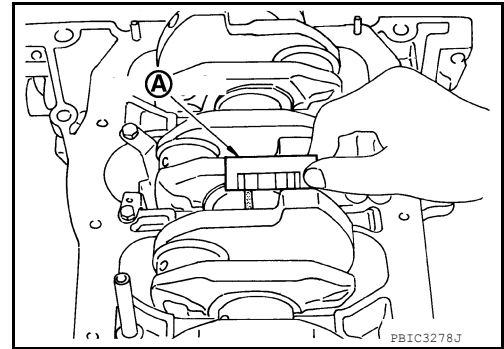

MAIN BEARING CRUSH HEIGHT

- When lower cylinder block is removed after being tightened to specified torque with main bearings (1) installed, tip end of bearing must protrude (B). Refer to [EM-98, "Disassembly and Assembly"](#).

(A) : Example

Standard: There must be crush height.

- If standard is not met, replace main bearings.

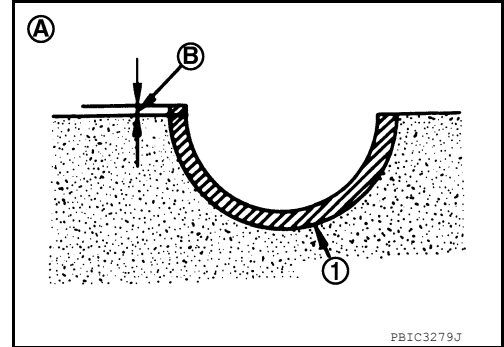

CONNECTING ROD BEARING CRUSH HEIGHT

- When connecting rod bearing cap is removed after being tightened to specified torque with connecting rod bearings (1) installed, tip end of bearing must protrude (B). Refer to [EM-98, "Disassembly and Assembly"](#).

(A) : Example

Standard: There must be crush height.

- If standard is not met, replace connecting rod bearings.

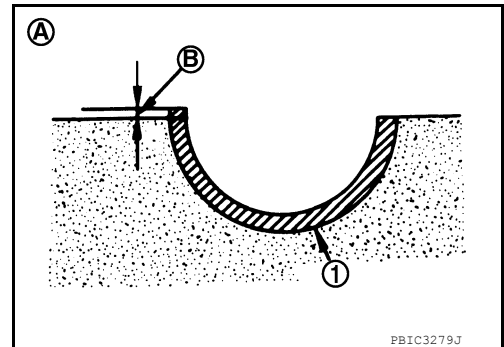

LOWER CYLINDER BLOCK BOLT OUTER DIAMETER

- Measure outer diameters (d1) and (d2) at two positions as shown.
- If reduction appears in (B) range, regard it as (d2).

Limit [(d1) - (d2)]: 0.13 mm (0.0051 in)

- If measured value exceeds limit (a large difference in dimensions) replace lower cylinder block bolt with new one.

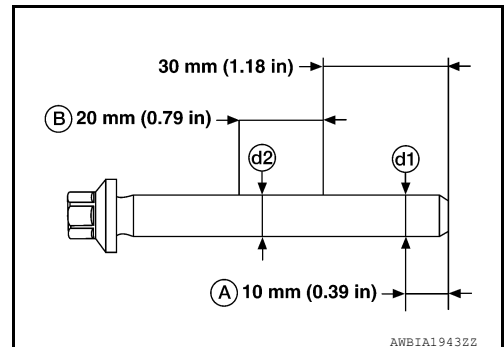

CONNECTING ROD BOLT OUTER DIAMETER

CYLINDER BLOCK

< UNIT DISASSEMBLY AND ASSEMBLY >

- Measure outer diameter (d) at position as shown.
- If reduction appears in position other than (d), regard it as (d).

Limit: 7.75 mm (0.3051 in)

- If measured value exceeds limit (large difference in dimensions) replace connecting rod bolt with new one.

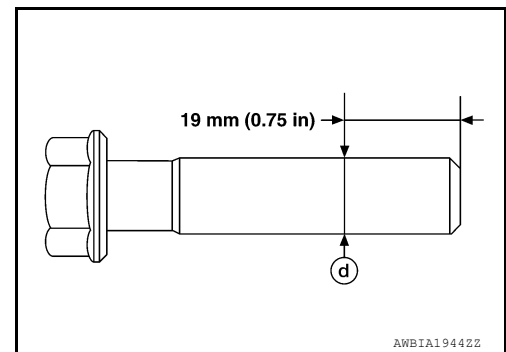

A

EM

C

D

E

F

G

H

I

J

K

L

M

N

O

P

HOW TO SELECT PISTON AND BEARING

< UNIT DISASSEMBLY AND ASSEMBLY >

HOW TO SELECT PISTON AND BEARING

How to Select Piston and Bearing

INFOID:000000011279983

DESCRIPTION

Selection points	Selection parts	Selection items	Selection methods
Between cylinder block to crankshaft	Main bearing	Main bearing grade (bearing thickness)	Determined by match of cylinder block bearing housing grade (inner diameter of housing) and crankshaft journal grade (outer diameter of journal)
Between crankshaft to connecting rod	Connecting rod bearing	Connecting rod bearing grade (bearing thickness)	Combining service grades for connecting rod big end inner diameter and crankshaft pin outer diameter determine connecting rod bearing selection
Between cylinder block to piston	Piston and piston pin assembly (The piston is available together with piston pin as an assembly)	Piston grade (piston outer diameter)	Piston grade = cylinder bore grade (inner diameter of bore)
*Between piston to connecting rod	—	—	—

*For the service parts, the grade for fitting cannot be selected between a piston pin and a connecting rod. (Only 0 grade is available.) The information at the shipment from the plant is described as a reference.

- The identification grade stamped on each part is the grade for the dimension measured in new condition. This grade cannot apply to reused parts.
- For reused or repaired parts, measure the dimension accurately. Determine the grade by comparing the measurement with the values of each selection table.
- For details of the measurement method of each part, the reuse standards, and the selection method of the selective fitting parts, follow the applicable procedures.

HOW TO SELECT A PISTON

When New Cylinder Block is Used:

- Check the cylinder bore grade on rear left side of cylinder block, and select a piston of the same grade.

- (A) : Front mark
- (B) : Piston pin bore grade
- (C) : Piston grade I.D. stamp
- (D) : Piston crown I.D. code stamp
- (E) : ID marks

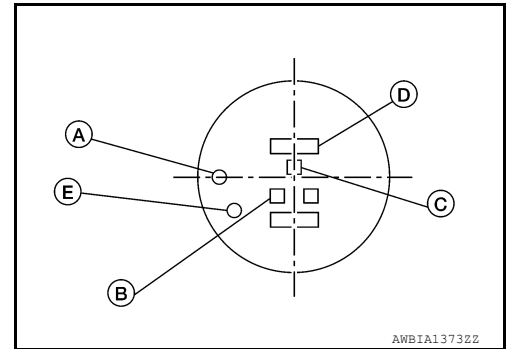

- If there is a corrected stamp mark on the cylinder block, use it as a correct reference.

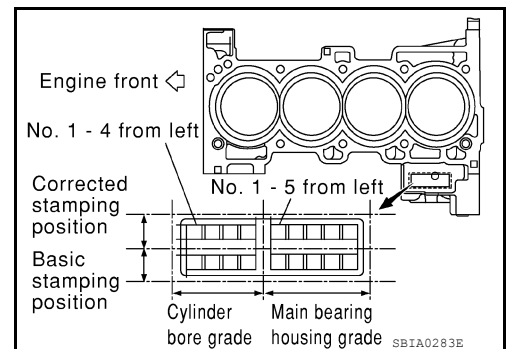

HOW TO SELECT PISTON AND BEARING

< UNIT DISASSEMBLY AND ASSEMBLY >

When a Cylinder Block is Reused:

1. Measure the cylinder block bore inner diameter.
2. Determine the bore grade by comparing the measurement with the values under the cylinder bore inner diameter of the "Piston Selection Table". Select the piston of the same grade.

Piston Selection Table

- For the piston selection table, refer to [EM-125, "Cylinder Block"](#).

NOTE:

- The piston is available together with piston pin as an assembly.
- The piston pin (piston pin bore) grade is provided only for the parts installed at the plant. For service parts, no grades can be selected. Only 0 grade is available.

HOW TO SELECT A CONNECTING ROD BEARING

When New Connecting Rod and Crankshaft are Used:

1. Apply big end inside diameter grade stamped on connecting rod side face to the row in the "Connecting Rod Bearing Selection Table".

- (A) : Oil splash
- (B) : Small end diameter grade
- (C) : Reference code
- (D) : Bearing stopper groove
- (E) : Reference code
- (F) : Cylinder No.
- (G) : Big end diameter grade

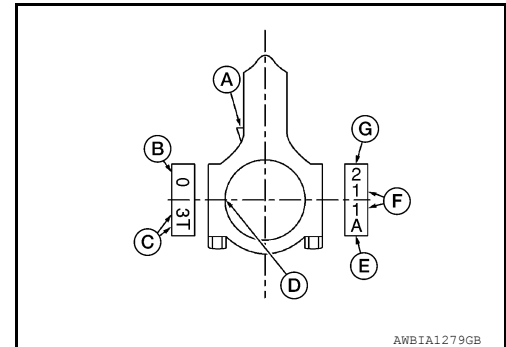

2. Apply pin diameter grade (B) stamped on crankshaft front side to the column in the "Connecting Rod Bearing Selection Table".
 - Journal diameter grade (A)
3. Read the symbol at the cross point of selected row and column in the "Connecting Rod Bearing Selection Table".
4. Apply the symbol obtained to connecting rod bearing grade table to select.

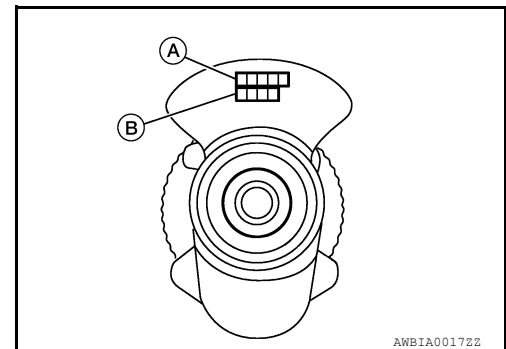

When Crankshaft and Connecting Rod are Reused:

1. Measure dimensions of the big end inner diameter of connecting rod and outer diameter of crankshaft pin individually.
2. Apply the dimension measured to the "Connecting Rod Bearing Selection Table" below.

HOW TO SELECT PISTON AND BEARING

< UNIT DISASSEMBLY AND ASSEMBLY >

Connecting Rod Bearing Selection Table

Mark	Outer diameter Unit: mm (in)	Connecting rod big end. inner diameter		Crankshaft pin outer diameter		Mark	Inner diameter Unit: mm (in)													
		0	1	2	3		4	5	6	7	8	9	A	B	C					
		48.000 - 48.001 (1.8898 - 1.8898)	48.001 - 48.002 (1.8898 - 1.8898)	48.002 - 48.003 (1.8898 - 1.8899)	48.003 - 48.004 (1.8899 - 1.8899)		48.000 - 48.001 (1.8898 - 1.8898)	48.001 - 48.002 (1.8898 - 1.8898)	48.002 - 48.003 (1.8898 - 1.8899)	48.003 - 48.004 (1.8899 - 1.8899)	48.004 - 48.005 (1.8899 - 1.8900)	48.005 - 48.006 (1.8899 - 1.8900)	48.006 - 48.007 (1.8899 - 1.8900)	48.007 - 48.008 (1.8899 - 1.8901)	48.008 - 48.009 (1.8901 - 1.8901)	48.009 - 48.010 (1.8901 - 1.8902)	48.010 - 48.011 (1.8902 - 1.8902)	48.011 - 48.012 (1.8902 - 1.8902)	48.012 - 48.013 (1.8902 - 1.8903)	
A	44.974 - 44.973 (1.7706 - 1.7706)	0	0	0	0	01	01	01	01	01	01	01	01	1	1	1	12	12	12	12
B	44.973 - 44.972 (1.7706 - 1.7705)	0	0	0	01	01	01	01	01	01	01	01	1	1	1	12	12	12	12	2
C	44.972 - 44.971 (1.7705 - 1.7705)	0	0	01	01	01	01	01	1	1	1	1	1	1	12	12	12	12	2	2
D	44.971 - 44.970 (1.7705 - 1.7705)	0	01	01	01	01	1	1	1	1	1	1	12	12	12	12	2	2	2	2
E	44.970 - 44.969 (1.7705 - 1.7704)	01	01	01	1	1	1	1	1	12	12	12	12	2	2	2	2	2	2	23
F	44.969 - 44.968 (1.7704 - 1.7704)	01	01	1	1	1	1	12	12	12	12	12	2	2	2	2	2	2	23	23
G	44.968 - 44.967 (1.7704 - 1.7704)	01	1	1	1	1	12	12	12	12	12	12	2	2	2	2	23	23	23	23
H	44.967 - 44.966 (1.7704 - 1.7703)	1	1	1	12	12	12	12	2	2	2	2	2	2	23	23	23	23	23	3
J	44.966 - 44.965 (1.7703 - 1.7703)	1	1	12	12	12	12	2	2	2	2	2	2	23	23	23	23	23	3	3
K	44.965 - 44.964 (1.7703 - 1.7702)	1	12	12	12	12	2	2	2	2	23	23	23	23	23	23	3	3	3	3
L	44.964 - 44.963 (1.7702 - 1.7702)	12	12	12	2	2	2	2	23	23	23	23	23	3	3	3	3	3	3	34
M	44.963 - 44.962 (1.7702 - 1.7702)	12	12	2	2	2	2	23	23	23	23	23	23	3	3	3	3	3	34	34
N	44.962 - 44.961 (1.7702 - 1.7701)	12	2	2	2	23	23	23	23	23	23	23	23	3	3	3	34	34	34	34
P	44.961 - 44.960 (1.7701 - 1.7701)	2	2	2	23	23	23	23	23	23	23	23	23	3	3	3	34	34	34	4
R	44.960 - 44.959 (1.7701 - 1.7700)	2	2	23	23	23	23	23	23	23	23	23	23	3	3	3	34	34	34	4
S	44.959 - 44.958 (1.7700 - 1.7700)	2	23	23	23	23	23	23	23	23	23	23	23	3	3	3	34	34	34	4
T	44.958 - 44.957 (1.7700 - 1.7700)	23	23	23	23	23	23	23	23	23	23	23	23	3	3	3	34	34	34	4
U	44.957 - 44.956 (1.7700 - 1.7699)	23	23	23	23	23	23	23	23	23	23	23	23	3	3	3	34	34	34	4

AMBIA0021GB

Connecting Rod Bearing Grade Table. Refer to [EM-130, "Connecting Rod Bearing"](#).

Undersize Bearing Usage Guide

- When the specified oil clearance is not obtained with standard size connecting rod bearing, use undersize (US) bearing.
- When using undersize bearing, measure the bearing inner diameter with bearing installed, and grind the crankshaft pin so that the oil clearance satisfies the standard.

Bearing Undersize Table

Size U.S.	Thickness
0.25 (0.0098)	1.622 - 1.630 (0.0639 - 0.0642)

Unit: mm (in)

CAUTION:

In grinding the crankshaft pin to use undersize bearings, do not damage the fillet R (All crankshaft pins).

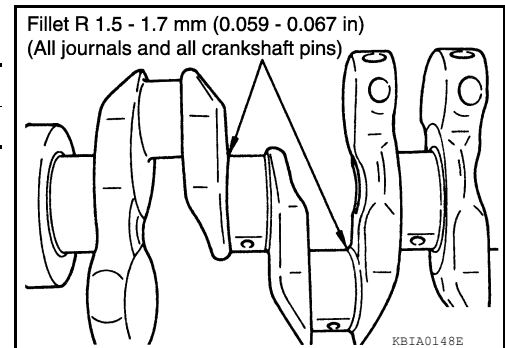

HOW TO SELECT A MAIN BEARING

When New Cylinder Block and Crankshaft are Used:

HOW TO SELECT PISTON AND BEARING

< UNIT DISASSEMBLY AND ASSEMBLY >

1. "Main Bearing Selection Table" rows correspond to bearing housing grade on rear left side of cylinder block.
 - If there is a corrected stamp mark on the cylinder block, use it as a correct reference.

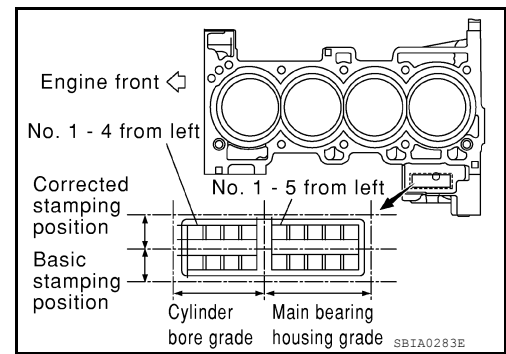

2. Apply journal diameter grade (A) stamped on crankshaft front side to column in "Main Bearing Selection Table".

(B) : Pin diameter grade

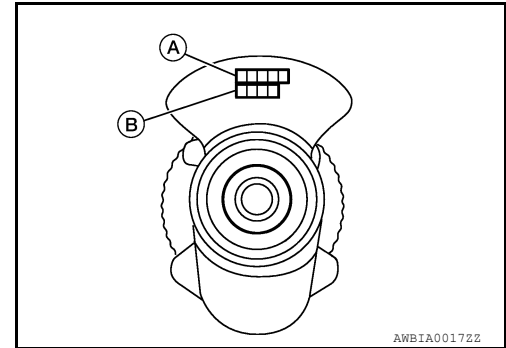

3. Find value at crossing of row and column in "Main Bearing Selection Table".

CAUTION:

- There are two main bearing selection tables. One is for odd-numbered journals (1, 3, and 5) and the other is for even-numbered journals (2 and 4). Make certain to use the appropriate table. This is due to differences in the specified clearances.

4. Apply the symbol obtained to "Main Bearing Grade Table" to select.

NOTE:

- Service parts are available as a set of both upper and lower.

When Cylinder Block and Crankshaft are Reused:

1. Measure inner diameter of cylinder block main bearing housing and outer diameter of crankshaft journal.
2. Apply measurement in above step 1 to the "Main Bearing Selection Table".
3. Follow steps 3 and 4 in "When New Cylinder Block and Crankshaft are Used".

HOW TO SELECT PISTON AND BEARING

< UNIT DISASSEMBLY AND ASSEMBLY >

Main Bearing Selection Table (No.1, 3, and No.5 journals)

Cylinder block main bearing housing inner diameter		Mark	Inner diameter Unit: mm (in)																								
			A	B	C	D	E	F	G	H	J	K	L	M	N	P	R	S	T	U	V	W	X	Y	4	7	
Mark	Outer diameter Unit: mm (in)	Inner diameter Unit: mm (in)																									
		58.944 - 58.945 (2.3206 - 2.3207)	58.945 - 58.946 (2.3207 - 2.3207)	58.946 - 58.947 (2.3207 - 2.3207)	58.947 - 58.948 (2.3207 - 2.3208)	58.948 - 58.949 (2.3208 - 2.3208)	58.949 - 58.950 (2.3209 - 2.3209)	58.950 - 58.951 (2.3209 - 2.3209)	58.951 - 58.952 (2.3209 - 2.3210)	58.952 - 58.953 (2.3209 - 2.3210)	58.953 - 58.954 (2.3210 - 2.3210)	58.954 - 58.955 (2.3210 - 2.3211)	58.955 - 58.956 (2.3211 - 2.3211)	58.956 - 58.957 (2.3211 - 2.3211)	58.957 - 58.958 (2.3211 - 2.3212)	58.958 - 58.959 (2.3212 - 2.3212)	58.959 - 58.960 (2.3212 - 2.3213)	58.960 - 58.961 (2.3213 - 2.3213)	58.961 - 58.962 (2.3213 - 2.3213)	58.962 - 58.963 (2.3213 - 2.3214)	58.963 - 58.964 (2.3214 - 2.3214)	58.964 - 58.965 (2.3214 - 2.3215)	58.965 - 58.966 (2.3215 - 2.3215)	58.966 - 58.967 (2.3215 - 2.3215)	58.967 - 58.968 (2.3215 - 2.3216)		
A	54.979 - 54.978 (2.1645 - 2.1645)	0	0	01	01	01	1	1	1	12	12	12	2	2	2	23	23	23	3	3	3	34	34	34	4	4	4
B	54.978 - 54.977 (2.1645 - 2.1644)	0	01	01	01	1	1	1	12	12	12	2	2	2	23	23	23	3	3	3	34	34	34	4	4	4	
C	54.977 - 54.976 (2.1644 - 2.1644)	01	01	01	1	1	1	12	12	12	2	2	2	23	23	23	3	3	3	3	34	34	34	4	4	4	
D	54.976 - 54.975 (2.1644 - 2.1644)	01	01	1	1	1	12	12	12	2	2	2	23	23	23	3	3	3	3	34	34	34	4	4	4	45	
E	54.975 - 54.974 (2.1644 - 2.1643)	01	1	1	1	12	12	12	2	2	2	23	23	23	3	3	3	3	34	34	34	4	4	4	45	45	
F	54.974 - 54.973 (2.1643 - 2.1643)	1	1	1	12	12	12	2	2	2	23	23	23	3	3	3	34	34	34	4	4	4	4	45	45	45	
G	54.973 - 54.972 (2.1643 - 2.1642)	1	1	12	12	12	2	2	2	23	23	23	3	3	3	34	34	34	4	4	4	4	45	45	45	5	
H	54.972 - 54.971 (2.1642 - 2.1642)	1	12	12	12	2	2	2	23	23	23	3	3	3	34	34	34	4	4	4	4	45	45	45	5	5	
J	54.971 - 54.970 (2.1642 - 2.1642)	12	12	12	2	2	2	23	23	23	3	3	3	34	34	34	4	4	4	4	45	45	45	5	5	5	
K	54.970 - 54.969 (2.1642 - 2.1641)	12	12	2	2	2	23	23	23	3	3	3	34	34	34	4	4	4	4	45	45	45	5	5	5	56	
L	54.969 - 54.968 (2.1641 - 2.1641)	12	2	2	2	23	23	23	3	3	3	34	34	34	4	4	4	4	45	45	45	5	5	5	56	56	
M	54.968 - 54.967 (2.1641 - 2.1641)	2	2	2	23	23	23	3	3	3	34	34	34	4	4	4	4	45	45	45	5	5	5	56	56	56	
N	54.967 - 54.966 (2.1641 - 2.1640)	2	2	23	23	23	3	3	3	34	34	34	4	4	4	4	45	45	45	5	5	5	56	56	56	6	
P	54.966 - 54.965 (2.1640 - 2.1640)	2	23	23	23	3	3	3	34	34	34	4	4	4	4	45	45	45	5	5	5	56	56	56	6	6	
R	54.965 - 54.964 (2.1640 - 2.1639)	23	23	23	3	3	3	34	34	34	4	4	4	45	45	45	5	5	5	56	56	56	6	6	6	6	
S	54.964 - 54.963 (2.1639 - 2.1639)	23	23	3	3	3	34	34	34	4	4	4	45	45	45	5	5	5	56	56	56	6	6	6	6	67	
T	54.963 - 54.962 (2.1639 - 2.1639)	23	3	3	3	34	34	34	4	4	4	45	45	45	5	5	5	56	56	56	6	6	6	6	67	67	
U	54.962 - 54.961 (2.1639 - 2.1638)	3	3	3	34	34	34	4	4	4	45	45	45	5	5	5	56	56	56	6	6	6	6	67	67	67	
V	54.961 - 54.960 (2.1638 - 2.1638)	3	3	34	34	34	4	4	4	45	45	45	5	5	5	56	56	56	6	6	6	6	67	67	67	7	
W	54.960 - 54.959 (2.1638 - 2.1637)	3	34	34	34	4	4	4	45	45	45	5	5	5	56	56	56	6	6	6	6	67	67	67	7	7	
X	54.959 - 54.958 (2.1637 - 2.1637)	34	34	34	4	4	4	45	45	45	5	5	5	56	56	56	6	6	6	6	67	67	67	7	7	7	
Y	54.958 - 54.957 (2.1637 - 2.1637)	34	34	4	4	4	45	45	45	5	5	5	56	56	56	6	6	6	6	67	67	67	7	7	7	7	
4	54.957 - 54.956 (2.1637 - 2.1636)	34	4	4	4	45	45	45	5	5	5	56	56	56	6	6	6	6	67	67	67	7	7	7	7	7	
7	54.956 - 54.955 (2.1636 - 2.1636)	4	4	4	45	45	45	5	5	5	56	56	56	6	6	6	67	67	67	7	7	7	7	7	7	7	

KBIA0149E

SERVICE DATA AND SPECIFICATIONS (SDS)

< SERVICE DATA AND SPECIFICATIONS (SDS)

SERVICE DATA AND SPECIFICATIONS (SDS)

SERVICE DATA AND SPECIFICATIONS (SDS)

General Specification

INFOID:0000000011279984

GENERAL SPECIFICATIONS

Cylinder arrangement		In-line 4
Displacement	cm ³ (cu in)	2,488 (151.82)
Bore and stroke	mm (in)	89.0 x 100.0 (3.504 x 3.940)
Valve arrangement		DOHC
Firing order		1-3-4-2
Number of piston rings	Compression	2
	Oil	1
Compression ratio		10.0
Compression pressure kPa (kg/cm ² , psi)/250 rpm	Standard	1,412 (14.4, 204.7)
	Minimum	1,216 (12.4, 176.3)
	Differential limit between cylinders	100 (1.0, 14.5)

Unit: degree

Valve timing ⇐ : Intake valve ⇐ : Exhaust valve						
	a	b	c	d	e	f
	224	244	8 (-32) ATDC	64 (24) ABDC	8	36

() : Valve timing control "ON"

Drive belt

INFOID:0000000011279985

DRIVE BELT

Tension of drive belt	Belt tension is not necessary, as it is automatically adjusted by drive belt auto-tensioner.
-----------------------	--

Spark Plug

INFOID:0000000011279986

SPARK PLUG

Unit: mm (in)

Make	DENSO
Standard type	FXE20HE11C
Spark plug gap (Nominal)	1.1 (0.043)

SERVICE DATA AND SPECIFICATIONS (SDS)

< SERVICE DATA AND SPECIFICATIONS (SDS)

Exhaust Manifold

INFOID:0000000011279988

EXHAUST MANIFOLD

Unit: mm (in)

Items	Limit
Surface distortion Exhaust manifold	0.3 (0.012)

Camshaft

INFOID:0000000011279989

CAMSHAFT

Unit: mm (in)

Items	Standard	Limit
Camshaft journal oil clearance	0.045 - 0.086 (0.0018 - 0.0034)	—
Camshaft bracket inner diameter	No. 1	28.000 - 28.021 (1.1024 - 1.1032)
	No. 2, 3, 4, 5	23.500 - 23.521 (0.9252 - 0.9260)
Camshaft journal diameter	No. 1	27.935 - 27.955 (1.0998 - 1.1006)
	No. 2, 3, 4, 5	23.435 - 23.455 (0.9226 - 0.9234)
Camshaft end play	0.115 - 0.188 (0.0045 - 0.0074)	—
Camshaft cam height "A"	Intake	45.865 - 46.055 (1.8057 - 1.8132)
	Exhaust	44.175 - 44.365 (1.7392 - 1.7467)
Camshaft runout [TIR* ²]	Less than 0.02 mm (0.0008)	—
Camshaft sprocket runout [TIR* ²]	—	0.15 (0.0059)

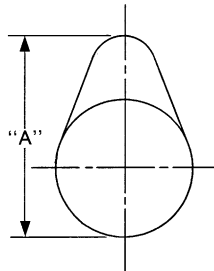

SEM671

*1: Cam wear limit

*2: Total indicator reading

VALVE LIFTER

Unit: mm (in)

Items	Standard
Valve lifter outer diameter	33.977 - 33.987 (1.3377 - 1.3381)
Valve lifter hole diameter	34.000 - 34.021 (1.3386 - 1.3394)
Valve lifter clearance	0.013 - 0.034 (0.0008 - 0.0012)

VALVE CLEARANCE

Unit: mm (in)

Items	Cold	Hot* (reference data)
Intake	0.240 - 0.320 (0.0094 - 0.0126)	0.304 - 0.416 (0.0120 - 0.0164)
Exhaust	0.260 - 0.340 (0.0102 - 0.0134)	0.308 - 0.432 (0.0121 - 0.0170)

*: Approximately 80°C (176°F)

SERVICE DATA AND SPECIFICATIONS (SDS)

< SERVICE DATA AND SPECIFICATIONS (SDS)

AVAILABLE VALVE LIFTER

Unit: mm (in)

Thickness	Identification (stamped) mark
3.00 (0.1181)	300H
3.02 (0.1189)	302H
3.04 (0.1197)	304H
3.06 (0.1205)	306H
3.08 (0.1213)	308H
3.10 (0.1220)	310H
3.12 (0.1228)	312H
3.14 (0.1236)	314H
3.16 (0.1244)	316H
3.18 (0.1252)	318H
3.20 (0.1260)	320H
3.22 (0.1268)	322H
3.24 (0.1276)	324H
3.26 (0.1283)	326H
3.28 (0.1291)	328H
3.30 (0.1299)	330H
3.32 (0.1307)	332H
3.34 (0.1315)	334H
3.36 (0.1323)	336H
3.38 (0.1331)	338H
3.40 (0.1339)	340H
3.42 (0.1346)	342H
3.44 (0.1354)	344H
3.46 (0.1362)	346H
3.48 (0.1370)	348H
3.50 (0.1378)	350H

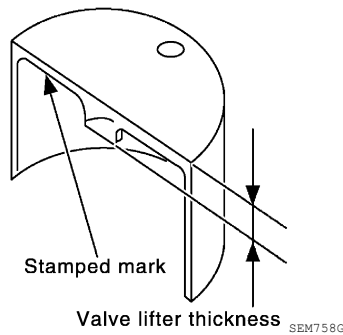

Cylinder Head

INFOID:000000011279990

CYLINDER HEAD

Unit: mm (in)

Items	Standard	Limit
Head surface distortion	Less than 0.03 (0.0012)	0.1 (0.004)

SERVICE DATA AND SPECIFICATIONS (SDS)

< SERVICE DATA AND SPECIFICATIONS (SDS)

Items	Standard	Limit
Normal cylinder head height "H"	129.3 - 129.5 (5.09 - 5.10)	—

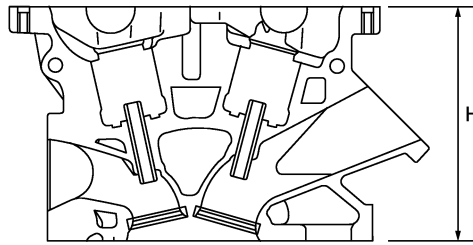

PBIC0924E

VALVE DIMENSIONS

Unit: mm (in)

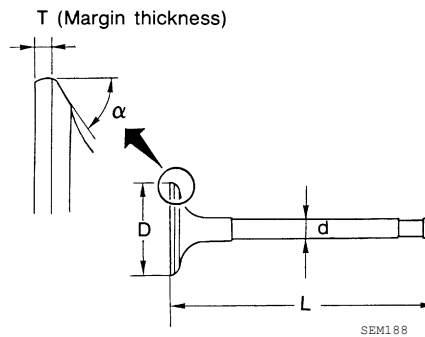

Valve head diameter "D"	Intake	35.5 - 35.8 (1.398 - 1.409)
	Exhaust	30.3 - 30.6 (1.193 - 1.205)
Valve length "L"	Intake	101.72 (4.005)
	Exhaust	102.78 (4.046)
Valve stem diameter "d"	Intake	5.965 - 5.980 (0.2348 - 0.2354)
	Exhaust	5.955 - 5.970 (0.2344 - 0.2350)
Valve seat angle " α "	Intake	44°15' - 44°45'
	Exhaust	
Valve margin "T"	Intake	1.15 - 1.45 (0.0453 - 0.0571)
	Exhaust	1.45 - 1.75 (0.0571 - 0.0689)
Valve stem end surface grinding limit		0.2 (0.008)

VALVE GUIDE

SERVICE DATA AND SPECIFICATIONS (SDS)

< SERVICE DATA AND SPECIFICATIONS (SDS)

Unit: mm (in)

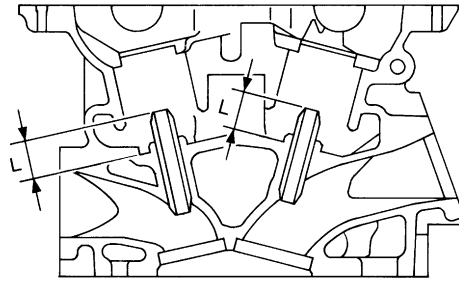

SEM950E

Items		Standard	Oversize (Service) [0.2 (0.008)]
Valve guide	Outer diameter	10.023 - 10.034 (0.3946 - 0.3950)	10.223 - 10.234 (0.4025 - 0.4029)
	Inner diameter (Finished size)	6.000 - 6.018 (0.2362 - 0.2369)	
Cylinder head valve guide hole diameter		9.975 - 9.996 (0.3927 - 0.3935)	10.175 - 10.196 (0.4006 - 0.4014)
Interference fit of valve guide		0.027 - 0.059 (0.0011 - 0.0023)	
Items		Standard	Limit
Valve guide clearance	Intake	0.020 - 0.053 (0.0008 - 0.0021)	0.08 (0.0031)
	Exhaust	0.030 - 0.063 (0.0012 - 0.0025)	0.09 (0.0035)
Projection length "L"	Intake	10.1 - 10.3 (0.398 - 0.406)	
	Exhaust	10.0 - 10.4 (0.394 - 0.409)	

VALVE SEAT

Unit: mm (in)

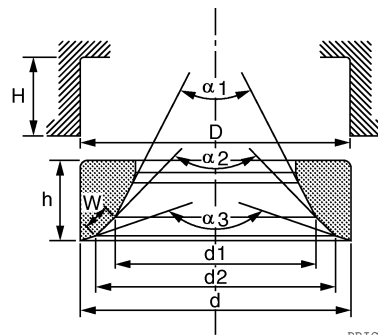

PBIC2745E

Items		Standard	Oversize (Service) [0.5 (0.020)]
Cylinder head seat recess diameter "D"	Intake	36.500 - 36.516 (1.4370 - 1.4376)	37.000 - 37.016 (1.4567 - 1.4573)
	Exhaust	31.500 - 31.516 (1.2402 - 1.2408)	32.000 - 32.016 (1.2598 - 1.2605)
Valve seat outer diameter "d"	Intake	36.597 - 36.613 (1.4408 - 1.4415)	37.097 - 37.113 (1.4605 - 1.4611)
	Exhaust	31.600 - 31.616 (1.2441 - 1.2447)	32.100 - 32.116 (1.2638 - 1.2644)
Valve seat interference fit	Intake	0.081 - 0.113 (0.0032 - 0.0044)	
	Exhaust	0.084 - 0.116 (0.0033 - 0.0046)	
Diameter "d1"*1	Intake	30.85 - 31.15 (1.2146 - 1.2264)	
	Exhaust	25.05 - 25.35 (0.9862 - 0.9980)	
Diameter "d2"*2	Intake	34.35 - 34.65 (1.3524 - 1.3642)	
	Exhaust	29.35 - 29.65 (1.1555 - 1.1673)	
Angle "α1"	Intake	60°	
	Exhaust	60°	

SERVICE DATA AND SPECIFICATIONS (SDS)

< SERVICE DATA AND SPECIFICATIONS (SDS)

Angle "α2"	Intake	88°45' - 90°15'	
	Exhaust	88°45' - 90°15'	
Angle "α3"	Intake	120°	
	Exhaust	120°	
Contacting width "W"*3	Intake	0.99 - 1.35 (0.0390 - 0.0531)	
	Exhaust	1.19 - 1.55 (0.0469 - 0.0610)	
Height "h"	Intake	5.9 - 6.0 (0.232 - 0.236)	5.0 - 5.1 (0.197 - 0.201)
	Exhaust	5.9 - 6.0 (0.232 - 0.236)	4.91 - 5.01 (0.1933 - 0.1972)
Depth "H"	6.0 (0.236)		

*1: Diameter made by intersection point of conic angles "α1" and "α2"

*2: Diameter made by intersection point of conic angles "α2" and "α3"

*3: Machining data

VALVE SPRING

Items	Intake	Exhaust
Free height	47.02 mm (1.8512 in)	47.75 mm (1.8799 in)
Installation height	35.96 mm (1.4157 in)	35.96 mm (1.4157 in)
Installation load	153N - 173N (15.6kg - 17.6kg, 34.4lb - 38.9lb)	153N - 173N (15.6kg - 17.6kg, 34.4lb - 38.9lb)
Height during valve open	25.76 mm (1.0142 in)	27.46 mm (1.0811 in)
Load with valve open	337N - 381N (34.4kg - 38.9kg, 75.8lb - 85.6lb)	302N - 340N (30.8kg - 34.7kg, 67.9lb - 76.4lb)
Identification color	White	Light blue
Out-of-Square	1.6 mm (0.063 in)	1.7 mm (0.067 in)

Cylinder Block

INFOID:0000000011279991

CYLINDER BLOCK

Unit: mm (in)

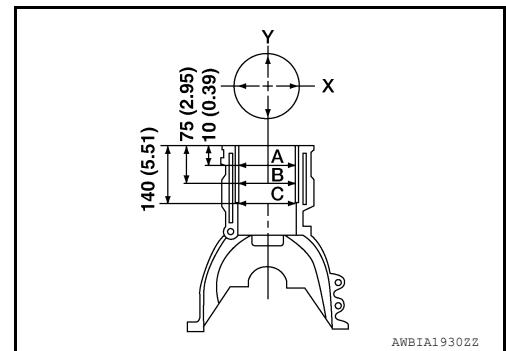

Surface distortion	Limit	0.1 (0.004)	
Cylinder bore	Standard	Grade No. 2	89.010 - 89.020 (3.5043 - 3.5047)
		Grade No. 3	89.020 - 89.030 (3.5047 - 3.5051)
	Wear limit	0.2 (0.008)	
Out-of-round (Difference between "X" and "Y")	Limit	0.015 (0.0006)	
Taper (Difference between "A" and "C")		0.01 (0.0004)	

SERVICE DATA AND SPECIFICATIONS (SDS)

< SERVICE DATA AND SPECIFICATIONS (SDS)

Main bearing housing inner diameter grade	Grade No. A	58.944 - 58.945 (2.3206 - 2.3207)
	Grade No. B	58.945 - 58.946 (2.3207 - 2.3207)
	Grade No. C	58.946 - 58.947 (2.3207 - 2.3207)
	Grade No. D	58.947 - 58.948 (2.3207 - 2.3208)
	Grade No. E	58.948 - 58.949 (2.3208 - 2.3208)
	Grade No. F	58.949 - 58.950 (2.3208 - 2.3209)
	Grade No. G	58.950 - 58.951 (2.3209 - 2.3209)
	Grade No. H	58.951 - 58.952 (2.3209 - 2.3209)
	Grade No. J	58.952 - 58.953 (2.3209 - 2.3210)
	Grade No. K	58.953 - 58.954 (2.3210 - 2.3210)
	Grade No. L	58.954 - 58.955 (2.3210 - 2.3211)
	Grade No. M	58.955 - 58.956 (2.3211 - 2.3211)
	Grade No. N	58.956 - 58.957 (2.3211 - 2.3211)
	Grade No. P	58.957 - 58.958 (2.3211 - 2.3212)
	Grade No. R	58.958 - 58.959 (2.3212 - 2.3212)
	Grade No. S	58.959 - 58.960 (2.3212 - 2.3213)
	Grade No. T	58.960 - 58.961 (2.3213 - 2.3213)
	Grade No. U	58.961 - 58.962 (2.3213 - 2.3213)
Grade No. V	58.962 - 58.963 (2.3213 - 2.3214)	
Grade No. W	58.963 - 58.964 (2.3214 - 2.3214)	
Grade No. X	58.964 - 58.965 (2.3214 - 2.3215)	
Grade No. Y	58.965 - 58.966 (2.3215 - 2.3215)	
Grade No. 4	58.966 - 58.967 (2.3215 - 2.3215)	
Grade No. 7	58.967 - 58.968 (2.3215 - 2.3216)	
Difference in inner diameter between cylinders	Standard	Less than 0.03 (0.0012)

AVAILABLE PISTON

Unit: mm (in)

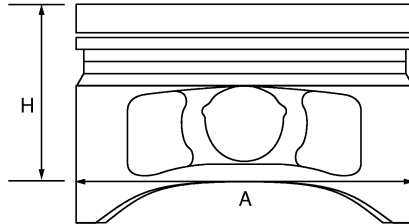

PBIC0188E

Piston skirt diameter "A"	Standard	Grade No. 2	88.990 - 89.000 (3.5035 - 3.5039)
		Grade No. 3	89.000 - 89.010 (3.5039 - 3.5043)
		Oversize (Service) [0.20 (0.008)]	89.180 - 89.210 (3.5110 - 3.5122)
Piston height "H" dimension			48.95 (1.9272)
Piston pin hole diameter	Grade No. 0	19.993 - 19.999 (0.7871 - 0.7874)	
	Grade No. 1	19.999 - 20.005 (0.7874 - 0.7876)	
Piston to cylinder bore clearance	Standard	0.010 - 0.030 (0.0004 - 0.0012)	
	Limit	0.08 (0.0031)	

PISTON RING

Unit: mm (in)

Items		Standard	Limit
Side clearance	Top	0.040 - 0.080 (0.0016 - 0.0031)	0.11 (0.0043)
	2nd	0.030 - 0.070 (0.0012 - 0.0028)	0.1 (0.004)
	Oil ring	0.045 - 0.125 (0.0018 - 0.0049)	—

SERVICE DATA AND SPECIFICATIONS (SDS)

< SERVICE DATA AND SPECIFICATIONS (SDS)

End gap	Top	0.21 - 0.31 (0.0083 - 0.0122)	0.54 (0.0213)
	2nd	0.37 - 0.52 (0.0146 - 0.0205)	0.80 (0.0315)
	Oil (rail ring)	0.20 - 0.45 (0.0079 - 0.0177)	0.90 (0.0354)

PISTON PIN

Unit: mm (in)

Items	Standard	Limit
Piston pin outer diameter	Grade No. 0	19.989 - 19.995 (0.7870 - 0.7872)
	Grade No. 1	19.995 - 20.001 (0.7872 - 0.7874)
Piston to piston pin oil clearance	0.002 - 0.006 (0.0001 - 0.0002)	—
Connecting rod bushing oil clearance	0.005 - 0.017 (0.0002 - 0.0007)	0.030 (0.0012)

CONNECTING ROD

Unit: mm (in)

Center distance		143.00 - 143.10 (5.63 - 5.63)
Bend [per 100 (3.94)]	Limit	0.15 (0.0059)
Torsion [per 100 (3.94)]	Limit	0.3 (0.012)
Connecting rod bushing inner diameter*	Grade No. 0	20.000 - 20.006 (0.7874 - 0.7876)
	Grade No. 1	20.006 - 20.012 (0.7876 - 0.7879)
Side clearance	Standard	0.20 - 0.35 (0.0079 - 0.0138)
	Limit	0.5 (0.020)
Connecting rod big end diameter	Grade No. 0	48.000 - 48.001 (1.8898 - 1.8898)
	Grade No. 1	48.001 - 48.002 (1.8898 - 1.8898)
	Grade No. 2	48.002 - 48.003 (1.8898 - 1.8899)
	Grade No. 3	48.003 - 48.004 (1.8899 - 1.8899)
	Grade No. 4	48.004 - 48.005 (1.8899 - 1.8900)
	Grade No. 5	48.005 - 48.006 (1.8900 - 1.8900)
	Grade No. 6	48.006 - 48.007 (1.8900 - 1.8900)
	Grade No. 7	48.007 - 48.008 (1.8900 - 1.8901)
	Grade No. 8	48.008 - 48.009 (1.8901 - 1.8901)
	Grade No. 9	48.009 - 48.010 (1.8901 - 1.8902)
	Grade No. A	48.010 - 48.011 (1.8902 - 1.8902)
	Grade No. B	48.011 - 48.012 (1.8902 - 1.8902)
Grade No. C	48.012 - 48.013 (1.8902 - 1.8903)	

*: After installing in connecting rod

CRANKSHAFT

Unit: mm (in)

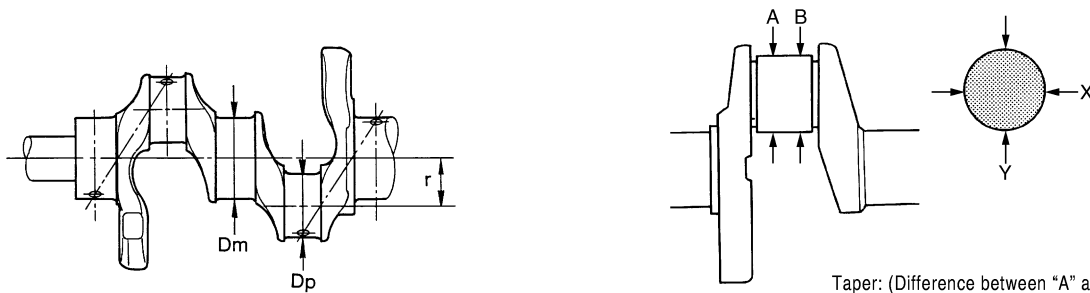

Taper: (Difference between "A" and "B")
Out-of-round: (Difference between "X" and "Y")

Center distance "r"		50.52 - 51.00 (1.9890 - 2.0079)
Out-of-round (Difference between "X" and "Y")	Limit	0.005 (0.0002)
Taper (Difference between "A" and "B")	Limit	0.005 (0.0002)
Runout [TIR*]	Limit	0.05 (0.0020)

SERVICE DATA AND SPECIFICATIONS (SDS)

< SERVICE DATA AND SPECIFICATIONS (SDS)

Crankshaft end play	Standard	0.10 - 0.26 (0.0039 - 0.0102)
	Limit	0.3 (0.012)
Pin journal diameter grade. "Dp"	Grade No. A	44.973 - 44.974 (1.7706 - 1.7706)
	Grade No. B	44.972 - 44.973 (1.7705 - 1.7706)
	Grade No. C	44.971 - 44.972 (1.7705 - 1.7705)
	Grade No. D	44.970 - 44.971 (1.7705 - 1.7705)
	Grade No. E	44.969 - 44.970 (1.7704 - 1.7705)
	Grade No. F	44.968 - 44.969 (1.7704 - 1.7704)
	Grade No. G	44.967 - 44.968 (1.7704 - 1.7704)
	Grade No. H	44.966 - 44.967 (1.7703 - 1.7704)
	Grade No. J	44.965 - 44.966 (1.7703 - 1.7703)
	Grade No. K	44.964 - 44.965 (1.7702 - 1.7703)
	Grade No. L	44.963 - 44.964 (1.7702 - 1.7702)
	Grade No. M	44.962 - 44.963 (1.7702 - 1.7702)
	Grade No. N	44.961 - 44.962 (1.7701 - 1.7702)
	Grade No. P	44.960 - 44.961 (1.7701 - 1.7701)
	Grade No. R	44.959 - 44.960 (1.7700 - 1.7701)
	Grade No. S	44.958 - 44.959 (1.7700 - 1.7700)
Grade No. T	44.957 - 44.958 (1.7700 - 1.7700)	
Grade No. U	44.956 - 44.957 (1.7699 - 1.7700)	
Main journal diameter grade. "Dm"	Grade No. A	54.978 - 54.979 (2.1645 - 2.1645)
	Grade No. B	54.977 - 54.978 (2.1644 - 2.1645)
	Grade No. C	54.967 - 54.977 (2.1644 - 2.1644)
	Grade No. D	54.975 - 54.976 (2.1644 - 2.1644)
	Grade No. E	54.974 - 54.975 (2.1643 - 2.1644)
	Grade No. F	54.973 - 54.974 (2.1643 - 2.1643)
	Grade No. G	54.972 - 54.973 (2.1642 - 2.1643)
	Grade No. H	54.971 - 54.972 (2.1642 - 2.1642)
	Grade No. J	54.970 - 54.971 (2.1642 - 2.1642)
	Grade No. K	54.969 - 54.970 (2.1641 - 2.1642)
	Grade No. L	54.968 - 54.969 (2.1641 - 2.1641)
	Grade No. M	54.967 - 54.968 (2.1641 - 2.1641)
	Grade No. N	54.966 - 54.967 (2.1640 - 2.1641)
	Grade No. P	54.965 - 54.966 (2.1640 - 2.1640)
	Grade No. R	54.964 - 54.965 (2.1639 - 2.1640)
	Grade No. S	54.963 - 54.964 (2.1639 - 2.1639)
	Grade No. T	54.962 - 54.963 (2.1639 - 2.1639)
	Grade No. U	54.961 - 54.962 (2.1638 - 2.1639)
	Grade No. V	54.960 - 54.961 (2.1638 - 2.1638)
Grade No. W	54.959 - 54.960 (2.1637 - 2.1638)	
Grade No. X	54.958 - 54.959 (2.1637 - 2.1637)	
Grade No. Y	54.957 - 54.958 (2.1637 - 2.1637)	
Grade No. 4	54.956 - 54.957 (2.1636 - 2.1637)	
Grade No. 7	54.955 - 54.956 (2.1636 - 2.1636)	

*: Total indicator reading

Main Bearing

INFOID:0000000011279992

MAIN BEARING

SERVICE DATA AND SPECIFICATIONS (SDS)

< SERVICE DATA AND SPECIFICATIONS (SDS)

Unit: mm (in)

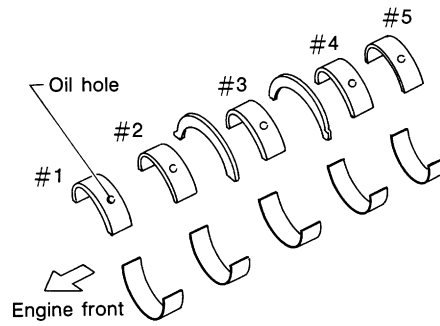

SEM685D

Grade number		Thickness	Identification color	Remarks
-1		1.970 - 1.973 (0.0776 - 0.0777)	Red	Grade and color are the same upper and lower bearings
0		1.973 - 1.976 (0.0777 - 0.0778)	Black	
1		1.976 - 1.979 (0.0778 - 0.0779)	Brown	
2		1.979 - 1.982 (0.0779 - 0.0780)	Green	
3		1.982 - 1.985 (0.0780 - 0.0781)	Yellow	
4		1.985 - 1.988 (0.0781 - 0.0783)	Blue	
5		1.988 - 1.991 (0.0783 - 0.0784)	Pink	
6		1.991 - 1.994 (0.0784 - 0.0785)	Purple	
7		1.994 - 1.997 (0.0785 - 0.0786)	White	
-10	UPR	1.970 - 1.973 (0.0776 - 0.0777)	Red	Grade and color are different for upper and lower bearings
	LWR	1.973 - 1.976 (0.0777 - 0.0778)	Black	
01	UPR	1.973 - 1.976 (0.0777 - 0.0778)	Black	
	LWR	1.976 - 1.979 (0.0778 - 0.0779)	Brown	
12	UPR	1.976 - 1.979 (0.0778 - 0.0779)	Brown	
	LWR	1.979 - 1.982 (0.0779 - 0.0780)	Green	
23	UPR	1.979 - 1.982 (0.0779 - 0.0780)	Green	
	LWR	1.982 - 1.985 (0.0780 - 0.0781)	Yellow	
34	UPR	1.982 - 1.985 (0.0780 - 0.0781)	Yellow	
	LWR	1.985 - 1.988 (0.0781 - 0.0783)	Blue	
45	UPR	1.985 - 1.988 (0.0781 - 0.0783)	Blue	
	LWR	1.988 - 1.991 (0.0783 - 0.0784)	Pink	
56	UPR	1.988 - 1.991 (0.0783 - 0.0784)	Pink	
	LWR	1.991 - 1.994 (0.0784 - 0.0785)	Purple	
67	UPR	1.991 - 1.994 (0.0784 - 0.0785)	Purple	
	LWR	1.994 - 1.997 (0.0785 - 0.0786)	White	

UNDERSIZE

Unit: mm (in)

Items	Thickness	Main journal diameter
0.25 (0.0098)	2.106 - 2.114 (0.0829 - 0.0832)	Grind so that bearing clearance is the specified value.

MAIN BEARING OIL CLEARANCE

SERVICE DATA AND SPECIFICATIONS (SDS)

< SERVICE DATA AND SPECIFICATIONS (SDS)

Unit: mm (in)

Main bearing oil clearance	Standard	No. 1 and 5	0.012 - 0.022 (0.0005 - 0.0009)
		No. 2 and 4	0.018 - 0.028 (0.0007 - 0.0011)
		No. 3	0.021 - 0.031 (0.0008 - 0.0012)
	Limit	0.1 (0.004)	

Connecting Rod Bearing

INFOID:000000011279993

CONNECTING ROD BEARING

Unit: mm (in)

Grade number	Thickness	Identification color	Remarks
0	1.493 - 1.496 (0.0588 - 0.0589)	Black	Grade and color are the same for upper and lower bearings.
1	1.496 - 1.499 (0.0589 - 0.0590)	Brown	
2	1.499 - 1.502 (0.0590 - 0.0591)	Green	
3	1.502 - 1.505 (0.0591 - 0.0593)	Yellow	
4	1.505 - 1.508 (0.0593 - 0.0594)	Blue	
01	UPR	1.493 - 1.496 (0.0588 - 0.0589)	Grade and color are different for upper and lower bearings.
	LWR	1.496 - 1.499 (0.0589 - 0.0590)	
12	UPR	1.496 - 1.499 (0.0589 - 0.0590)	
	LWR	1.499 - 1.502 (0.0590 - 0.0591)	
23	UPR	1.499 - 1.502 (0.0590 - 0.0591)	
	LWR	1.502 - 1.505 (0.0591 - 0.0593)	
34	UPR	1.502 - 1.505 (0.0591 - 0.0593)	
	LWR	1.505 - 1.508 (0.0593 - 0.0594)	

UNDERSIZE

Unit: mm (in)

Items	Thickness	Crank pin journal diameter
0.25 (0.0098)	1.622 - 1.630 (0.0639 - 0.0642)	Grind so that bearing clearance is the specified value.

CONNECTING ROD BEARING OIL CLEARANCE

Unit: mm (in)

Items	Standard	Limit
Connecting rod bearing oil clearance	0.035 - 0.045 (0.0014 - 0.0018)	0.1 (0.004)