

EXL

SECTION

EXTERIOR LIGHTING SYSTEM

A
B
C
D
E
F
G
H
I
J
K
EXL
M
N
O
P

CONTENTS

<p>HALOGEN HEADLAMP</p> <p>PRECAUTION 7</p> <p>PRECAUTIONS 7</p> <p style="padding-left: 20px;">Precaution for Supplemental Restraint System (SRS) "AIR BAG" and "SEAT BELT PRE-TENSIONER" 7</p> <p style="padding-left: 20px;">Precaution for Work 7</p> <p>PREPARATION 8</p> <p>PREPARATION 8</p> <p style="padding-left: 20px;">Special Service Tool 8</p> <p>SYSTEM DESCRIPTION 9</p> <p>COMPONENT PARTS 9</p> <p style="padding-left: 20px;">Component Parts Location 9</p> <p style="padding-left: 20px;">Optical Sensor 10</p> <p style="padding-left: 20px;">Hazard Switch 11</p> <p>SYSTEM 12</p> <p>HEADLAMP SYSTEM 12</p> <p style="padding-left: 20px;">HEADLAMP SYSTEM : System Description 12</p> <p style="padding-left: 20px;">HEADLAMP SYSTEM : Fail-Safe 12</p> <p>AUTO LIGHT SYSTEM 13</p> <p style="padding-left: 20px;">AUTO LIGHT SYSTEM : System Description 13</p> <p>DAYTIME RUNNING LIGHT SYSTEM 14</p> <p style="padding-left: 20px;">DAYTIME RUNNING LIGHT SYSTEM : System Description 14</p> <p>TURN SIGNAL AND HAZARD WARNING LAMP SYSTEM 14</p> <p style="padding-left: 20px;">TURN SIGNAL AND HAZARD WARNING LAMP SYSTEM : System Description 15</p> <p>PARKING, LICENSE PLATE, SIDE MARKER AND TAIL LAMP SYSTEM 15</p>	<p>PARKING, LICENSE PLATE, SIDE MARKER AND TAIL LAMP SYSTEM : System Description 15</p> <p>PARKING, LICENSE PLATE, SIDE MARKER AND TAIL LAMP SYSTEM : Fail-Safe 16</p> <p>FRONT FOG LAMP SYSTEM 16</p> <p style="padding-left: 20px;">FRONT FOG LAMP SYSTEM : System Description 17</p> <p style="padding-left: 20px;">FRONT FOG LAMP SYSTEM : Fail-Safe 17</p> <p>EXTERIOR LAMP BATTERY SAVER SYSTEM 17</p> <p style="padding-left: 20px;">EXTERIOR LAMP BATTERY SAVER SYSTEM : System Description 18</p> <p>DIAGNOSIS SYSTEM (BCM) 19</p> <p>WITH INTELLIGENT KEY 19</p> <p style="padding-left: 20px;">WITH INTELLIGENT KEY : CONSULT Function (BCM - COMMON ITEM) 19</p> <p style="padding-left: 20px;">WITH INTELLIGENT KEY : CONSULT Function (BCM - HEADLAMP) 19</p> <p style="padding-left: 20px;">WITH INTELLIGENT KEY : CONSULT Function (BCM - FLASHER) 21</p> <p>WITHOUT INTELLIGENT KEY 21</p> <p style="padding-left: 20px;">WITHOUT INTELLIGENT KEY : CONSULT Function (BCM - COMMON ITEM) 21</p> <p style="padding-left: 20px;">WITHOUT INTELLIGENT KEY : CONSULT Function (BCM - HEADLAMP) 22</p> <p style="padding-left: 20px;">WITHOUT INTELLIGENT KEY : CONSULT Function (BCM - FLASHER) 23</p> <p>DIAGNOSIS SYSTEM (IPDM E/R) 24</p> <p style="padding-left: 20px;">CONSULT Function (IPDM E/R) 24</p> <p>ECU DIAGNOSIS INFORMATION 27</p> <p>BCM, IPDM E/R 27</p> <p style="padding-left: 20px;">List of ECU Reference 27</p> <p>WIRING DIAGRAM 28</p> <p>HEADLAMP 28</p>
--	---

Wiring Diagram	28	HAZARD SWITCH	90
DAYTIME RUNNING LIGHT SYSTEM	35	Component Function Check	90
Wiring Diagram	35	Diagnosis Procedure	90
AUTO LIGHT SYSTEM	42	TURN SIGNAL LAMP CIRCUIT	92
Wiring Diagram	42	Description	92
FRONT FOG LAMP SYSTEM	49	Component Function Check	92
Wiring Diagram	49	Diagnosis Procedure	92
TURN SIGNAL AND HAZARD WARNING LAMP SYSTEM	55	B121A FRONT FOG LAMP LH POWER SUP- PLY CIRCUIT	96
Wiring Diagram	55	DTC Logic	96
PARKING, LICENSE PLATE AND TAIL LAMPS SYSTEM	62	Diagnosis Procedure	96
Wiring Diagram	62	B1231 DAYTIME RUNNING LIGHT RH POW- ER SUPPLY CIRCUIT	97
STOP LAMP	73	DTC Logic	97
Wiring Diagram	73	Diagnosis Procedure	97
BACK-UP LAMP	77	B1256 FRONT FOG LAMP RH POWER SUP- PLY CIRCUIT	98
Wiring Diagram	77	DTC Logic	98
BASIC INSPECTION	81	Diagnosis Procedure	98
DIAGNOSIS AND REPAIR WORKFLOW	81	B20CB DAYTIME RUNNING LIGHT LH POW- ER SUPPLY CIRCUIT	99
Work Flow	81	DTC Logic	99
INSPECTION AND ADJUSTMENT	84	Diagnosis Procedure	99
ADDITIONAL SERVICE WHEN REPLACING CONTROL UNIT	84	B20CE HEADLAMP (HI) LH POWER SUP- PLY CIRCUIT	100
ADDITIONAL SERVICE WHEN REPLACING CONTROL UNIT : Description	84	DTC Logic	100
ADDITIONAL SERVICE WHEN REPLACING CONTROL UNIT : Special Repair Requirement	84	Diagnosis Procedure	100
SENSOR INITIALIZE	84	B20CF HEADLAMP (HI) RH POWER SUP- PLY CIRCUIT	101
SENSOR INITIALIZE : Description	84	DTC Logic	101
SENSOR INITIALIZE : Special Repair Require- ment	84	Diagnosis Procedure	101
DTC/CIRCUIT DIAGNOSIS	85	B20D0 HEADLAMP (LO) LH POWER SUP- PLY CIRCUIT	102
POWER SUPPLY AND GROUND CIRCUIT	85	DTC Logic	102
BCM (BODY CONTROL SYSTEM) (WITH INTEL- LIGENT KEY SYSTEM)	85	Diagnosis Procedure	102
BCM (BODY CONTROL SYSTEM) (WITH INTEL- LIGENT KEY SYSTEM) : Diagnosis Procedure	85	B20D1 HEADLAMP (LO) RH POWER SUP- PLY CIRCUIT	103
BCM (BODY CONTROL SYSTEM) (WITHOUT IN- TELLIGENT KEY SYSTEM)	85	DTC Logic	103
BCM (BODY CONTROL SYSTEM) (WITHOUT INTELLIGENT KEY SYSTEM) : Diagnosis Proce- dure	85	Diagnosis Procedure	103
OPTICAL SENSOR	87	B20D2 PARKING LAMP POWER SUPPLY CIRCUIT	104
Component Function Check	87	DTC Logic	104
Diagnosis Procedure	87	Diagnosis Procedure	104
		B20D4 TAIL LAMP LH POWER SUPPLY CIR- CUIT	105
		DTC Logic	105
		Diagnosis Procedure	105
		B20D5 TAIL LAMP RH POWER SUPPLY CIRCUIT	106

DTC Logic	106	Removal and Installation	125	
Diagnosis Procedure	106	SIDE TURN SIGNAL LAMP	126	A
SYMPTOM DIAGNOSIS	107	Removal and Installation	126	
EXTERIOR LIGHTING SYSTEM SYMPTOMS.	107	Bulb Replacement	126	B
Symptom Table	107	REAR COMBINATION LAMP	127	
NORMAL OPERATING CONDITION	109	Exploded View	127	
Description	109	Removal and Installation	127	C
BOTH SIDE HEADLAMPS (HI) ARE NOT		Bulb Replacement	127	
TURNED ON	110	HIGH-MOUNTED STOP LAMP	129	
Description	110	Exploded View	129	D
Diagnosis Procedure	110	Removal and Installation	129	
BOTH SIDE HEADLAMPS (LO) ARE NOT		Bulb Replacement	129	E
TURNED ON	111	BACK-UP LAMP ASSEMBLY	130	
Description	111	Exploded View	130	
Diagnosis Procedure	111	Removal and Installation	130	F
PARKING, LICENSE PLATE, SIDE MARKER		Bulb Replacement	130	
AND TAIL LAMPS ARE NOT TURNED ON ...	112	LICENSE PLATE LAMP	132	
Description	112	Exploded View	132	G
Diagnosis Procedure	112	Removal and Installation	132	
BOTH SIDE FRONT FOG LAMPS ARE NOT		Bulb Replacement	132	
TURNED ON	113	UNIT DISASSEMBLY AND ASSEMBLY .	134	H
Description	113	FRONT COMBINATION LAMP	134	
Diagnosis Procedure	113	Exploded View	134	I
PERIODIC MAINTENANCE	114	Disassembly and Assembly	134	
HEADLAMP AIMING ADJUSTMENT	114	REAR COMBINATION LAMP	135	
Inspection	114	Exploded View	135	J
Aiming Adjustment Procedure	115	Disassembly and Assembly	135	
FRONT FOG LAMP AIMING ADJUSTMENT ..	117	SERVICE DATA AND SPECIFICATIONS		K
Aiming Adjustment Procedure	117	(SDS)	136	
REMOVAL AND INSTALLATION	119	SERVICE DATA AND SPECIFICATIONS		EXL
FRONT COMBINATION LAMP	119	(SDS)	136	
Exploded View	119	Bulb Specifications	136	
Removal and Installation	119	LED HEADLAMP		M
Bulb Replacement	119	PRECAUTION	137	
FRONT FOG LAMP	121	PRECAUTIONS	137	
Exploded View	121	Precaution for Supplemental Restraint System		N
Removal and Installation	121	(SRS) "AIR BAG" and "SEAT BELT PRE-TEN-		
Bulb Replacement	121	SIONER"	137	O
OPTICAL SENSOR	123	Precaution for Work	137	
Exploded View	123	PREPARATION	138	
Removal and Installation	123	PREPARATION	138	P
COMBINATION SWITCH	124	Special Service Tool	138	
Exploded View	124	SYSTEM DESCRIPTION	139	
Removal and Installation	124	COMPONENT PARTS	139	
HAZARD SWITCH	125	Component Parts Location	139	
Exploded View	125	Optical Sensor	140	

Hazard Switch	141	ECU DIAGNOSIS INFORMATION	158
SYSTEM	142	BCM, IPDM E/R	158
HEADLAMP SYSTEM	142	List of ECU Reference	158
HEADLAMP SYSTEM : System Description	142	WIRING DIAGRAM	159
HEADLAMP SYSTEM : Fail-Safe	142	HEADLAMP	159
AUTO LIGHT SYSTEM	143	Wiring Diagram	159
AUTO LIGHT SYSTEM : System Description	143	DAYTIME RUNNING LIGHT SYSTEM	165
DAYTIME RUNNING LIGHT SYSTEM	144	Wiring Diagram	165
DAYTIME RUNNING LIGHT SYSTEM : System Description	144	AUTO LIGHT SYSTEM	172
HEADLAMP AIMING CONTROL SYSTEM (AUTO)	144	Wiring Diagram	172
HEADLAMP AIMING CONTROL SYSTEM (AUTO) : System Diagram	145	FRONT FOG LAMP SYSTEM	179
HEADLAMP AIMING CONTROL SYSTEM (AUTO) : System Description	145	Wiring Diagram	179
TURN SIGNAL AND HAZARD WARNING LAMP SYSTEM	145	TURN SIGNAL AND HAZARD WARNING LAMP SYSTEM	185
TURN SIGNAL AND HAZARD WARNING LAMP SYSTEM : System Description	146	Wiring Diagram	185
PARKING, LICENSE PLATE, SIDE MARKER AND TAIL LAMP SYSTEM	146	PARKING, LICENSE PLATE AND TAIL LAMPS SYSTEM	192
PARKING, LICENSE PLATE, SIDE MARKER AND TAIL LAMP SYSTEM : System Description	146	Wiring Diagram	192
PARKING, LICENSE PLATE, SIDE MARKER AND TAIL LAMP SYSTEM : Fail-Safe	147	STOP LAMP	203
FRONT FOG LAMP SYSTEM	147	Wiring Diagram	203
FRONT FOG LAMP SYSTEM : System Description	148	BACK-UP LAMP	207
FRONT FOG LAMP SYSTEM : Fail-Safe	148	Wiring Diagram	207
EXTERIOR LAMP BATTERY SAVER SYSTEM	148	HEADLAMP AIMING SYSTEM (AUTOMATIC)	211
EXTERIOR LAMP BATTERY SAVER SYSTEM : System Description	149	Wiring Diagram	211
DIAGNOSIS SYSTEM (BCM)	150	BASIC INSPECTION	218
WITH INTELLIGENT KEY	150	DIAGNOSIS AND REPAIR WORKFLOW	218
WITH INTELLIGENT KEY : CONSULT Function (BCM - COMMON ITEM)	150	Work Flow	218
WITH INTELLIGENT KEY : CONSULT Function (BCM - HEADLAMP)	150	INSPECTION AND ADJUSTMENT	221
WITH INTELLIGENT KEY : CONSULT Function (BCM - FLASHER)	152	ADDITIONAL SERVICE WHEN REPLACING CONTROL UNIT	221
WITHOUT INTELLIGENT KEY	152	ADDITIONAL SERVICE WHEN REPLACING CONTROL UNIT : Description	221
WITHOUT INTELLIGENT KEY : CONSULT Function (BCM - COMMON ITEM)	152	ADDITIONAL SERVICE WHEN REPLACING CONTROL UNIT : Special Repair Requirement ..	221
WITHOUT INTELLIGENT KEY : CONSULT Function (BCM - HEADLAMP)	153	SENSOR INITIALIZE	221
WITHOUT INTELLIGENT KEY : CONSULT Function (BCM - FLASHER)	154	SENSOR INITIALIZE : Description	221
DIAGNOSIS SYSTEM (IPDM E/R)	155	SENSOR INITIALIZE : Special Repair Requirement	221
CONSULT Function (IPDM E/R)	155	LED HEADLAMP OPERATION INSPECTION	223
		Diagnosis Procedure	223
		DTC/CIRCUIT DIAGNOSIS	224
		POWER SUPPLY AND GROUND CIRCUIT	224

BCM (BODY CONTROL SYSTEM) (WITH INTELLIGENT KEY SYSTEM)	224	B20CF HEADLAMP (HI) RH POWER SUPPLY CIRCUIT	245	A
BCM (BODY CONTROL SYSTEM) (WITH INTELLIGENT KEY SYSTEM) : Diagnosis Procedure ...	224	DTC Logic	245	
		Diagnosis Procedure	245	
BCM (BODY CONTROL SYSTEM) (WITHOUT INTELLIGENT KEY SYSTEM)	224	B20D0 HEADLAMP (LO) LH POWER SUPPLY CIRCUIT	246	B
BCM (BODY CONTROL SYSTEM) (WITHOUT INTELLIGENT KEY SYSTEM) : Diagnosis Procedure	224	DTC Logic	246	
		Diagnosis Procedure	246	C
OPTICAL SENSOR	226	B20D1 HEADLAMP (LO) RH POWER SUPPLY CIRCUIT	247	D
Component Function Check	226	DTC Logic	247	
Diagnosis Procedure	226	Diagnosis Procedure	247	
HAZARD SWITCH	229	B20D2 PARKING LAMP POWER SUPPLY CIRCUIT	248	E
Component Function Check	229	DTC Logic	248	
Diagnosis Procedure	229	Diagnosis Procedure	248	F
TURN SIGNAL LAMP CIRCUIT	231	B20D4 TAIL LAMP LH POWER SUPPLY CIRCUIT	249	G
Description	231	DTC Logic	249	
Component Function Check	231	Diagnosis Procedure	249	
Diagnosis Procedure	231	B20D5 TAIL LAMP RH POWER SUPPLY CIRCUIT	250	H
B121A FRONT FOG LAMP LH POWER SUPPLY CIRCUIT	235	DTC Logic	250	
DTC Logic	235	Diagnosis Procedure	250	I
Diagnosis Procedure	235	B20DB HEIGHT SENSOR INITIALIZE NOT DONE	251	J
B1231 DAYTIME RUNNING LIGHT RH POWER SUPPLY CIRCUIT	236	DTC Logic	251	
DTC Logic	236	Diagnosis Procedure	251	
Diagnosis Procedure	236	B20E2 LED HEADLAMP RH	252	K
B1256 FRONT FOG LAMP RH POWER SUPPLY CIRCUIT	237	DTC Logic	252	
DTC Logic	237	Diagnosis Procedure	252	
Diagnosis Procedure	237	B20E3 LED HEADLAMP LH	253	EXL
B1C00 HEIGHT SENSOR POWER SUPPLY CIRCUIT	238	DTC Logic	253	
DTC Logic	238	Diagnosis Procedure	253	
Diagnosis Procedure	238	SYMPTOM DIAGNOSIS	254	M
B1C02 REAR HEIGHT SENSOR SIGNAL	239	EXTERIOR LIGHTING SYSTEM SYMPTOMS	254	N
DTC Logic	239	Symptom Table	254	
Diagnosis Procedure	239	NORMAL OPERATING CONDITION	256	O
B1C07 AIMING MOTOR DRIVE SIGNAL	241	Description	256	
DTC Logic	241	BOTH SIDE HEADLAMPS (HI) ARE NOT TURNED ON	257	P
Diagnosis Procedure	241	Description	257	
B20CB DAYTIME RUNNING LIGHT LH POWER SUPPLY CIRCUIT	243	Diagnosis Procedure	257	
DTC Logic	243	BOTH SIDE HEADLAMPS (LO) ARE NOT TURNED ON	258	
Diagnosis Procedure	243	Description	258	
B20CE HEADLAMP (HI) LH POWER SUPPLY CIRCUIT	244	Diagnosis Procedure	258	
DTC Logic	244			
Diagnosis Procedure	244			

PARKING, LICENSE PLATE, SIDE MARKER AND TAIL LAMPS ARE NOT TURNED ON ..	259	Exploded View	273
Description	259	Removal and Installation	273
Diagnosis Procedure	259	SIDE TURN SIGNAL LAMP	274
BOTH SIDE FRONT FOG LAMPS ARE NOT TURNED ON	260	Removal and Installation	274
Description	260	Bulb Replacement	274
Diagnosis Procedure	260	REAR COMBINATION LAMP	275
PERIODIC MAINTENANCE	261	Exploded View	275
HEADLAMP AIMING ADJUSTMENT	261	Removal and Installation	275
Inspection	261	Bulb Replacement	275
Aiming Adjustment Procedure	262	HIGH-MOUNTED STOP LAMP	277
FRONT FOG LAMP AIMING ADJUSTMENT .	264	Exploded View	277
Aiming Adjustment Procedure	264	Removal and Installation	277
REMOVAL AND INSTALLATION	266	Bulb Replacement	277
FRONT COMBINATION LAMP	266	BACK-UP LAMP ASSEMBLY	278
Exploded View	266	Exploded View	278
Removal and Installation	266	Removal and Installation	278
Bulb Replacement	266	Bulb Replacement	278
HEIGHT SENSOR	268	LICENSE PLATE LAMP	280
Exploded View	268	Exploded View	280
Removal and Installation - Rear Height Sensor ...	268	Removal and Installation	280
FRONT FOG LAMP	269	Bulb Replacement	280
Exploded View	269	UNIT DISASSEMBLY AND ASSEMBLY ..	282
Removal and Installation	269	FRONT COMBINATION LAMP	282
Bulb Replacement	269	Exploded View	282
OPTICAL SENSOR	271	Disassembly and Assembly	282
Exploded View	271	REAR COMBINATION LAMP	283
Removal and Installation	271	Exploded View	283
COMBINATION SWITCH	272	Disassembly and Assembly	283
Exploded View	272	SERVICE DATA AND SPECIFICATIONS (SDS)	284
Removal and Installation	272	SERVICE DATA AND SPECIFICATIONS (SDS)	284
HAZARD SWITCH	273	Bulb Specifications	284

PRECAUTION

PRECAUTIONS

Precaution for Supplemental Restraint System (SRS) "AIR BAG" and "SEAT BELT PRE-TENSIONER"

INFOID:000000011280700

The Supplemental Restraint System such as "AIR BAG" and "SEAT BELT PRE-TENSIONER", used along with a front seat belt, helps to reduce the risk or severity of injury to the driver and front passenger for certain types of collision. Information necessary to service the system safely is included in the SR and SB section of this Service Manual.

WARNING:

- To avoid rendering the SRS inoperative, which could increase the risk of personal injury or death in the event of a collision which would result in air bag inflation, all maintenance must be performed by an authorized NISSAN/INFINITI dealer.
- Improper maintenance, including incorrect removal and installation of the SRS, can lead to personal injury caused by unintentional activation of the system. For removal of Spiral Cable and Air Bag Module, see the SR section.
- Do not use electrical test equipment on any circuit related to the SRS unless instructed to in this Service Manual. SRS wiring harnesses can be identified by yellow and/or orange harnesses or harness connectors.

PRECAUTIONS WHEN USING POWER TOOLS (AIR OR ELECTRIC) AND HAMMERS

WARNING:

- When working near the Airbag Diagnosis Sensor Unit or other Airbag System sensors with the Ignition ON or engine running, DO NOT use air or electric power tools or strike near the sensor(s) with a hammer. Heavy vibration could activate the sensor(s) and deploy the air bag(s), possibly causing serious injury.
- When using air or electric power tools or hammers, always switch the Ignition OFF, disconnect the battery and wait at least three minutes before performing any service.

Precaution for Work

INFOID:000000011280701

- When removing or disassembling each component, be careful not to damage or deform it. If a component may be subject to interference, be sure to protect it with a shop cloth.
- When removing (disengaging) components with a screwdriver or similar tool, be sure to wrap the component with a shop cloth or vinyl tape to protect it.
- Protect the removed parts with a shop cloth and prevent them from being dropped.
- Replace a deformed or damaged clip.
- If a part is specified as a non-reusable part, always replace it with a new one.
- Be sure to tighten bolts and nuts securely to the specified torque.
- After installation is complete, be sure to check that each part works properly.
- Follow the steps below to clean components:
 - Water soluble dirt:
 - Dip a soft cloth into lukewarm water, wring the water out of the cloth and wipe the dirty area.
 - Then rub with a soft, dry cloth.
 - Oily dirt:
 - Dip a soft cloth into lukewarm water with mild detergent (concentration: within 2 to 3%) and wipe the dirty area.
 - Then dip a cloth into fresh water, wring the water out of the cloth and wipe the detergent off.
 - Then rub with a soft, dry cloth.
 - Do not use organic solvent such as thinner, benzene, alcohol or gasoline.
 - For genuine leather seats, use a genuine leather seat cleaner.

A
B
C
D
E
F
G
H
I
J
K
M
N
O
P

EXL

< PREPARATION >

PREPARATION

PREPARATION

Special Service Tool

INFOID:000000011280702

The actual shape of the tools may differ from those illustrated here.

Tool number (TechMate No.) Tool name	Description
— (J-46534) Trim Tool Set	Removing trim components

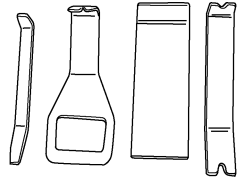

AWJIA0483ZZ

COMPONENT PARTS

< SYSTEM DESCRIPTION >

[HALOGEN HEADLAMP]

SYSTEM DESCRIPTION

COMPONENT PARTS

Component Parts Location

INFOID:0000000011280703

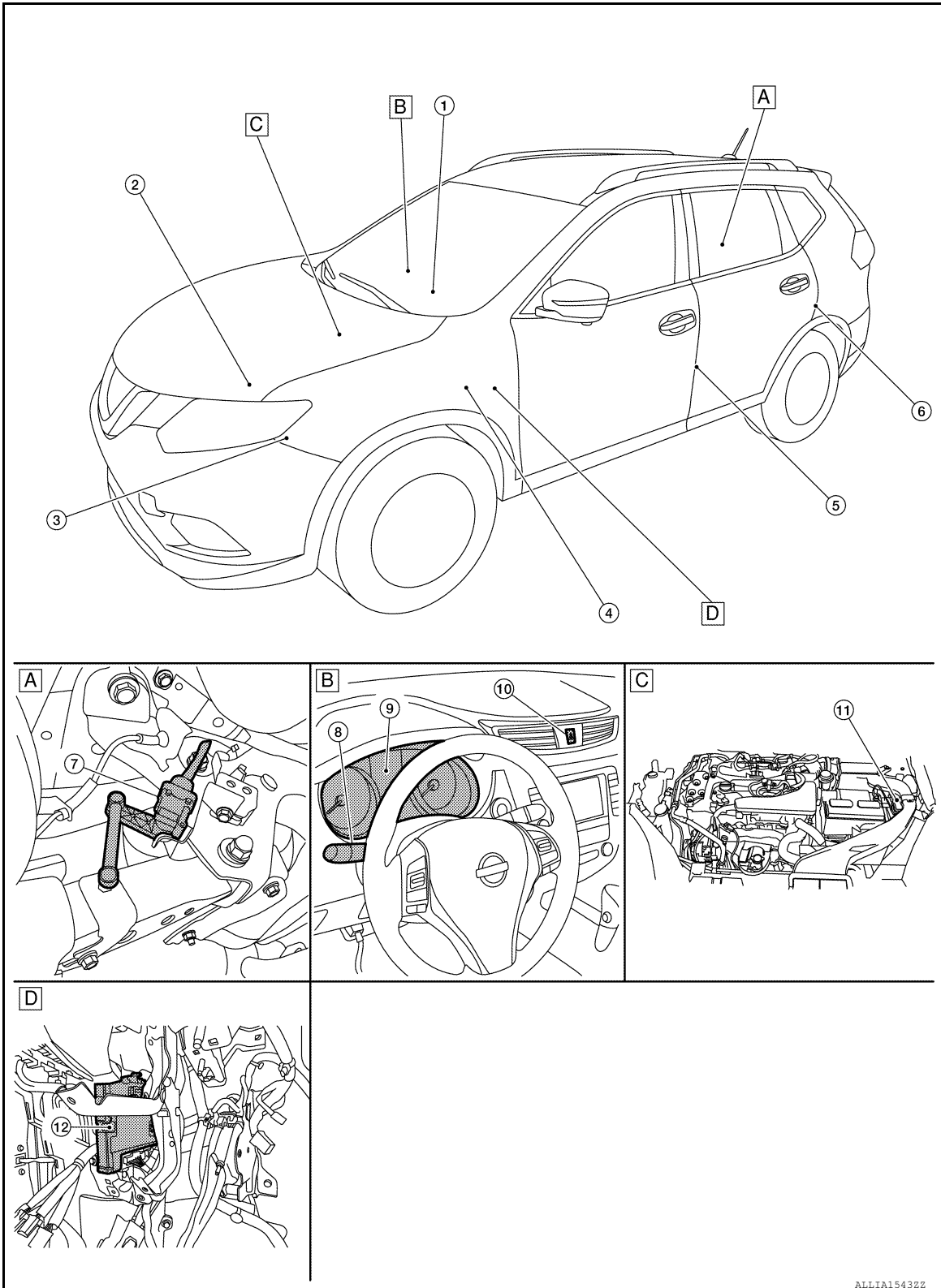

ALLIA15432Z

COMPONENT PARTS

[HALOGEN HEADLAMP]

< SYSTEM DESCRIPTION >

- A. Right rear wheel area B. Instrument panel C. Engine compartment
 D. Left side of instrument panel (view with trim panel removed)

No.	Part	Function
1.	Optical sensor	Refer to EXL-10, "Optical Sensor" .
2.	LED headlamp control module	Turns the headlamps ON according to the power supply from IPDM E/R.
3.	Headlamp aiming motor	Moves the headlamps up/down based on inputs from the rear height sensor.
4.	Parking brake switch	Transmits the parking brake switch signal to the combination meter to operate the daytime running light system.
5.	Front door switch LH (RH similar)	Transmits the door open signal to the BCM to operate the autolight system.
6.	Rear door switch LH (RH similar)	
7.	Rear height sensor	Sends the vehicles pitch angle signal to the IPDM E/R necessary for adjusting the headlamp aiming motors.
8.	Combination switch (Lighting and turn signal switch)	Refer to BCS-9, "COMBINATION SWITCH READING SYSTEM : System Description" (with Intelligent Key system) or BCS-81, "COMBINATION SWITCH READING SYSTEM : System Description" (without Intelligent Key system).
9.	Combination meter	Refer to MWI-8, "METER SYSTEM : System Description" .
10.	Hazard switch	Refer to EXL-11, "Hazard Switch" .
11.	IPDM E/R	<ul style="list-style-type: none"> Supplies voltage to the load according to the request from BCM (via CAN communication). Refer to PCS-6, "Component Parts Location" for detailed installation location.
12.	BCM	<ul style="list-style-type: none"> Detects each switch condition by the combination switch reading function. Judges that the exterior lamps are turned ON according to the vehicle condition. Requests the headlamp (HI/LO), tail lamp and front fog lamp ON to IPDM E/R (via CAN communication). Requests high beam indicator lamp ON to the combination meter (via CAN communication). Judges the outside brightness from the optical sensor signal. Judges the ON/OFF timing according to the vehicle condition. Judges the ON/OFF status of the exterior lamp according to the outside brightness and the vehicle condition. Refer to BCS-7, "BODY CONTROL SYSTEM : Component Parts Location" (with Intelligent Key system) or BCS-79, "BODY CONTROL SYSTEM : Component Parts Location" (without Intelligent Key system).

Optical Sensor

INFOID:000000011280704

Optical sensor converts the outside brightness (lux) to voltage and transmits the optical sensor signal to BCM.

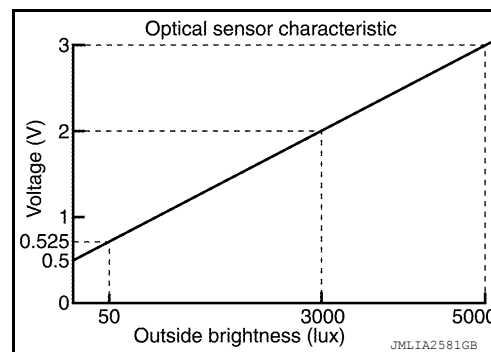

COMPONENT PARTS

< SYSTEM DESCRIPTION >

[HALOGEN HEADLAMP]

Hazard Switch

INFOID:000000011280705

Inputs the hazard switch ON/OFF signal to BCM.

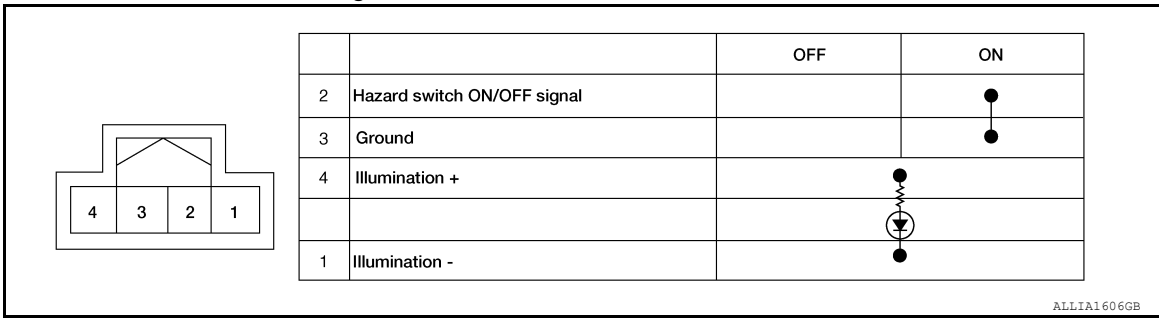

A
B
C
D
E
F
G
H
I
J
K
EXL
M
N
O
P

SYSTEM

HEADLAMP SYSTEM

HEADLAMP SYSTEM : System Description

INFOID:000000011280706

SYSTEM DIAGRAM

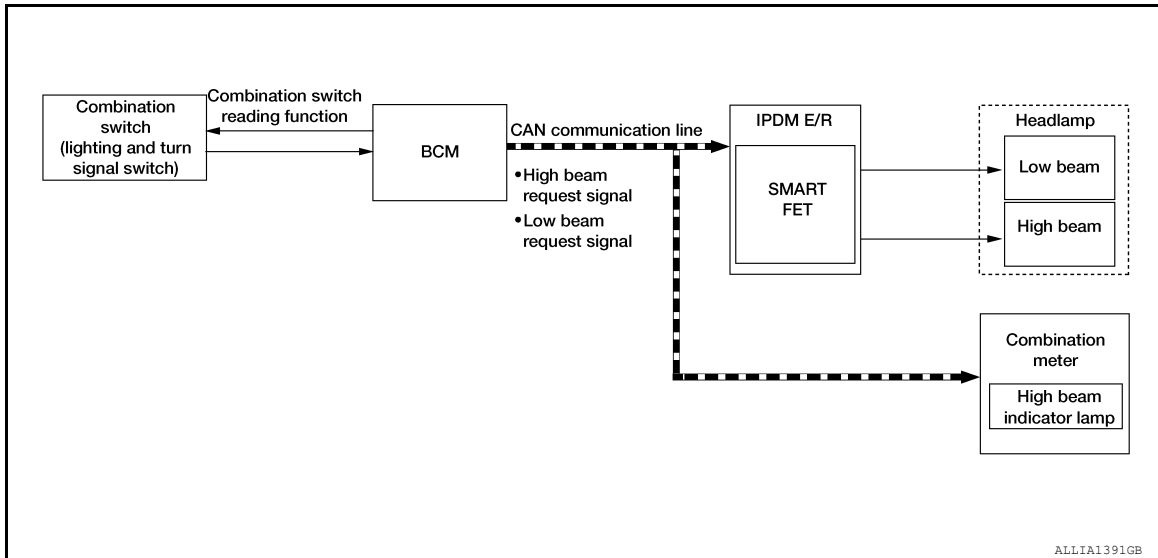

OUTLINE

Headlamp is controlled by combination switch reading function and headlamp control function of BCM, and Smart FET control function of IPDM E/R.

HEADLAMP (LO) OPERATION

- BCM detects the combination switch condition with the combination switch reading function.
- BCM transmits the low beam request signal to IPDM E/R with CAN communication according to the headlamp (LO) ON condition.

Headlamp (LO) ON condition:

- Lighting switch 2ND
- Lighting switch AUTO (auto light function ON judgment)
- Lighting switch AUTO, with the front fog lamp switch ON and the ignition switch ON
- Lighting switch PASS

HEADLAMP (HI) OPERATION

- BCM transmits the high beam request signal to IPDM E/R and the combination meter with CAN communication according to the headlamp (HI) ON condition.

Headlamp (HI) ON condition:

- Lighting switch HI with the lighting switch 2ND or AUTO (auto light function ON judgment)
- Lighting switch PASS
- Lighting switch AUTO, with the front fog lamp switch ON, the ignition switch ON and lighting switch HI
- Combination meter turns the high beam indicator lamp ON according to the high beam request signal.
- IPDM E/R turns the headlamp ON according to the high beam request signal.

HEADLAMP SYSTEM : Fail-Safe

INFOID:000000011280707

CAN COMMUNICATION CONTROL

When CAN communication with BCM is impossible, IPDM E/R performs fail-safe control. After CAN communication recovers normally, it also returns to normal control.

If no CAN communication is available with BCM

SYSTEM

< SYSTEM DESCRIPTION >

[HALOGEN HEADLAMP]

Control part	Fail-safe operation
Headlamp	<ul style="list-style-type: none"> • Turns ON the headlamp low beam when the ignition switch is turned ON • Turns OFF the headlamp low beam when the ignition switch is turned OFF

AUTO LIGHT SYSTEM

AUTO LIGHT SYSTEM : System Description

INFOID:000000011280708

SYSTEM DIAGRAM

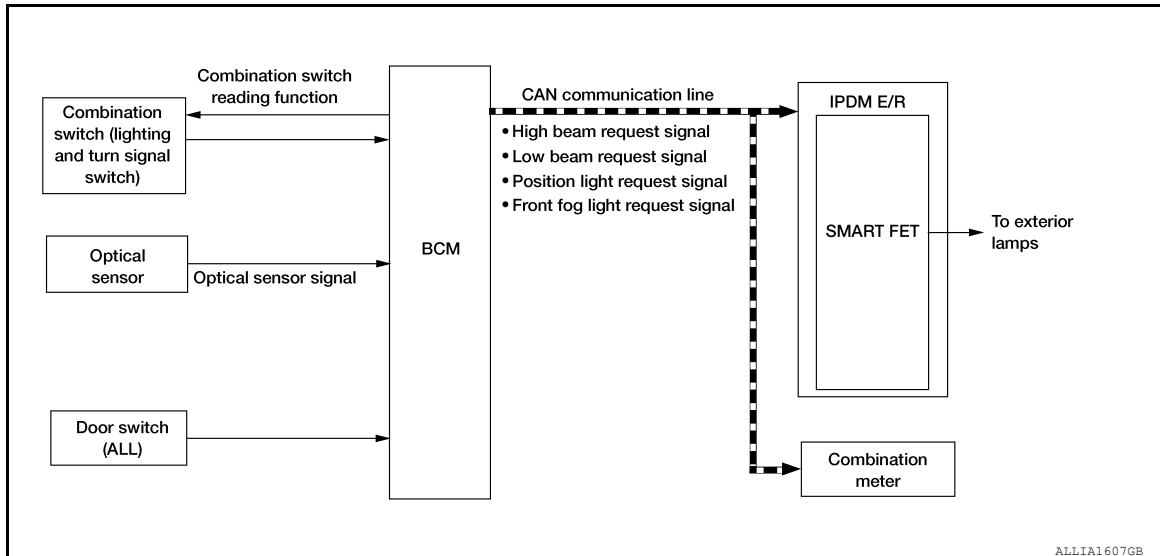

OUTLINE

- Auto light system is controlled by each function of BCM and IPDM E/R.

Controlled by BCM:

- Combination switch reading function
- Headlamp control function
- Auto light function
- Delay timer function
- Auto light adjustment system

Controlled by IPDM E/R:

- Auto light system has the auto light function and delay timer function.
- Auto light function automatically turns ON/OFF the exterior lamps* and each illumination automatically, depending on the outside brightness.
- When auto light system turns the exterior lamps ON with the ignition switch OFF, delay timer function turns the exterior lamps OFF, depending on the vehicle condition with the auto light function after a certain period of time.

*: Headlamp (LO/HI), parking lamp, side marker lamp, tail lamp and front fog lamp (Headlamp HI and front fog lamp depend on the combination switch condition).

AUTO LIGHT FUNCTION

- BCM detects the combination switch condition with the combination switch reading function.
- BCM supplies voltage to optical sensor when the ignition switch is turned ON or ACC.
- Optical sensor converts outside brightness (lux) to voltage and transmits the optical sensor signal to BCM.
- BCM judges outside brightness from the optical sensor signal and judges ON/OFF condition of the exterior lamp and each illumination according to the outside brightness.
- BCM transmits each request signal to IPDM E/R and combination meter via CAN communication according to ON/OFF condition by the auto light function.

NOTE:

ON/OFF timing differs based on the sensitivity from the setting. The setting can be set by CONSULT. Refer to [BCS-19. "HEADLAMP : CONSULT Function \(BCM - HEADLAMP\)"](#).

AUTO LIGHT ADJUSTMENT SYSTEM

A
B
C
D
E
F
G
H
I
J
K

EXL

M
N
O
P

SYSTEM

[HALOGEN HEADLAMP]

< SYSTEM DESCRIPTION >

The auto light adjustment system automatically dims/brightens the display according to brightness outside the vehicle when lighting switch 1ST, lighting switch 2ND or lighting switch AUTO is operated. Refer to [EXL-13, "AUTO LIGHT SYSTEM : System Description"](#).

DELAY TIMER FUNCTION

BCM turns the exterior lamp OFF depending on the vehicle condition with the auto light function when the ignition switch is turned OFF.

- Turns the exterior lamp OFF 5 minutes after detecting that any door opens. (Door switch ON).
- Turns the exterior lamp OFF a certain period of time* after closing all doors. (Door switch ON→OFF).
- Turns the exterior lamp OFF with the ignition switch ACC or the light switch OFF.

*: The preset time is 45 seconds. The timer operating time can be set by CONSULT. Refer to [BCS-19, "HEADLAMP : CONSULT Function \(BCM - HEADLAMP\)"](#) (with Intelligent Key system) or [BCS-90, "HEADLAMP : CONSULT Function \(BCM - HEADLAMP\)"](#) (without Intelligent Key system).

NOTE:

When any position other than the light switch AUTO is set, the auto light system function switches to the exterior lamp battery saver function.

DAYTIME RUNNING LIGHT SYSTEM

DAYTIME RUNNING LIGHT SYSTEM : System Description

INFOID:000000011280709

SYSTEM DIAGRAM

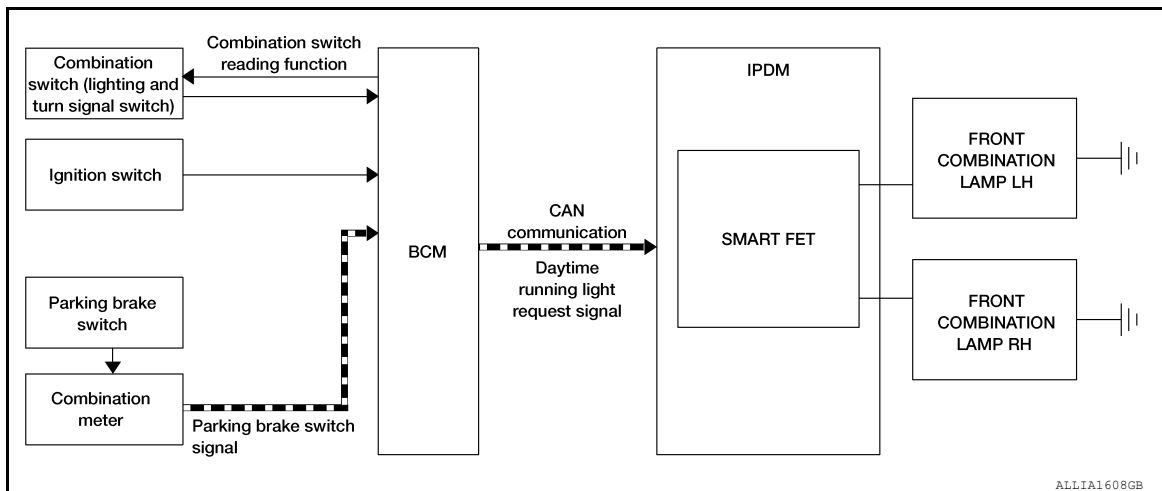

OUTLINE

- Daytime running light is controlled by daytime running light control function and combination switch reading function of BCM, and smart FET of IPDM E/R.

DAYTIME RUNNING LIGHT OPERATION

- BCM detects the combination switch condition by the combination switch reading function.
- BCM detects the vehicle condition according to ignition switch
- BCM detects the parking brake condition by the parking brake switch signal received from combination meter using CAN communication.
- BCM transmits the daytime running light request signal to IPDM E/R using CAN communication according to the daytime running light ON condition.

Daytime running light ON condition:

- Vehicle condition READY
- Lighting switch OFF or 1ST
- Lighting switch AUTO, and the auto light function OFF judgment
- Parking brake switch OFF
- IPDM E/R controls the daytime running light request signal.
- Power is supplied from the IPDM E/R to the daytime lights.

TURN SIGNAL AND HAZARD WARNING LAMP SYSTEM

TURN SIGNAL AND HAZARD WARNING LAMP SYSTEM : System Description

INFOID:000000011280710

SYSTEM DIAGRAM

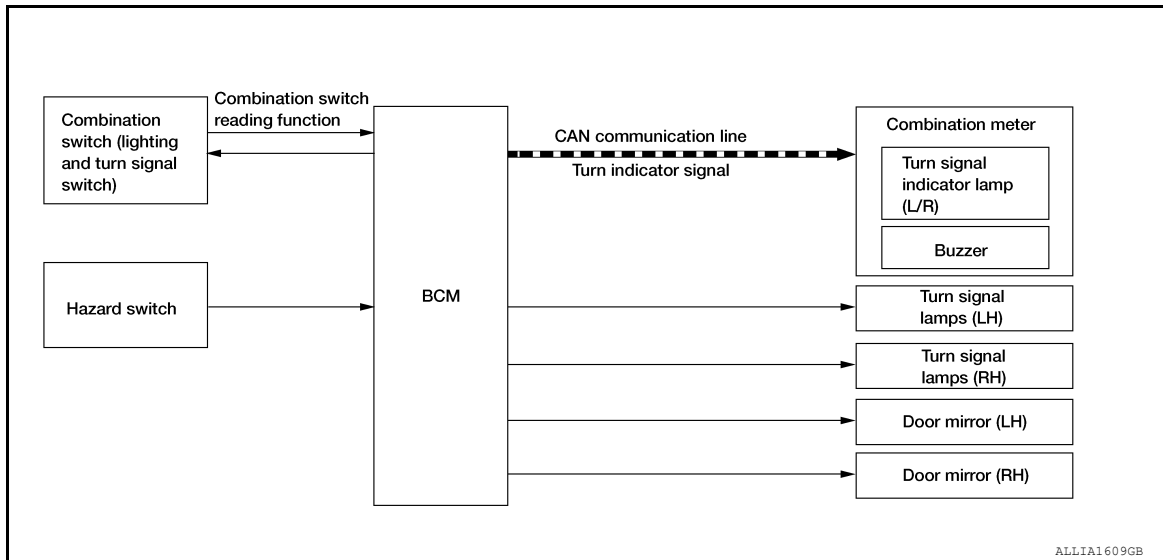

OUTLINE

Turn signal lamp and the hazard warning lamp is controlled by combination switch reading function and the flasher control function of BCM.

TURN SIGNAL LAMP OPERATION

- BCM detects the combination switch condition by the combination switch reading function.
- BCM supplies voltage to the right (left) turn signal lamp circuit when the ignition switch is ON and the turn signal switch is in the right (left) position. BCM blinks the turn signal lamp.

HAZARD WARNING LAMP OPERATION

BCM supplies voltage to both turn signal lamp circuit when the hazard switch is ON. BCM blinks the hazard warning lamp.

TURN SIGNAL INDICATOR LAMP AND TURN SIGNAL OPERATION

- BCM transmits the turn signal indicator lamp signal to the combination meter using CAN communication while the turn signal lamp and the hazard warning lamp are operating.
- Combination meter outputs the turn signal sound with the integrated buzzer while blinking the turn signal indicator lamp according to the turn signal indicator lamp signal.

HIGH FLASHER OPERATION

- BCM detects the turn signal lamp circuit status from the current value.
- BCM increases the turn signal lamp blinking speed if the bulb or harness open is detected with the turn signal lamp operating.

NOTE:

The blinking speed is normal while operating the hazard warning lamp.

PARKING, LICENSE PLATE, SIDE MARKER AND TAIL LAMP SYSTEM

PARKING, LICENSE PLATE, SIDE MARKER AND TAIL LAMP SYSTEM : System De-

A
B
C
D
E
F
G
H
I
J
K
EXL
M
N
O
P

scription

SYSTEM DIAGRAM

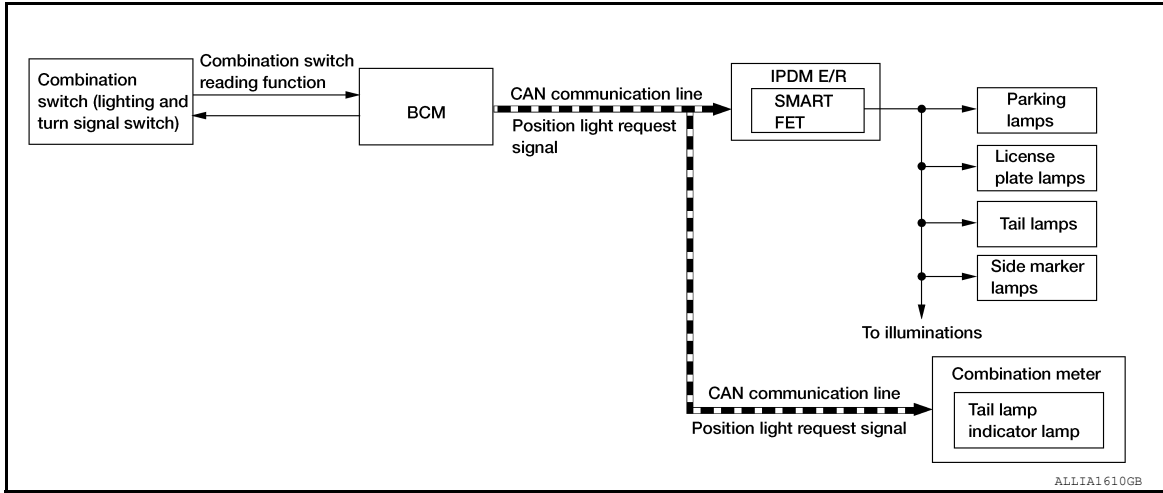

OUTLINE

Parking, license plate, side marker and tail lamps are controlled by combination switch reading function and headlamp control function of BCM, and smart FET of IPDM E/R.

PARKING, LICENSE PLATE, SIDE MARKER AND TAIL LAMPS OPERATION

- BCM detects the combination switch condition by the combination switch reading function.
- BCM transmits the position light request signal to IPDM E/R and the combination meter via CAN communication according to the ON/OFF condition of the parking, license plate, side marker and tail lamps.

Parking, license plate, side marker and tail lamps ON condition:

- Lighting switch 1ST
- Lighting switch 2ND
- Lighting switch AUTO, and the auto light function ON judgment
- Lighting switch AUTO, with the front fog lamp switch ON and the ignition switch ON
- IPDM E/R turns the parking, license plate, side marker and tail lamps ON according to the position light request signal.
- Combination meter turns the tail lamp indicator lamp ON according to the position light request signal.

PARKING, LICENSE PLATE, SIDE MARKER AND TAIL LAMP SYSTEM : Fail-Safe

CAN COMMUNICATION CONTROL

When CAN communication with BCM is impossible, IPDM E/R performs fail-safe control. After CAN communication recovers normally, it also returns to normal control.

If no CAN communication is available with BCM

Control part	Fail-safe operation
<ul style="list-style-type: none"> • Parking lamp • License plate lamp • Illumination • Tail lamp • Side marker lamp 	<ul style="list-style-type: none"> • Turns ON the tail lamp when the ignition switch is turned ON • Turns OFF the tail lamp when the ignition switch is turned OFF

FRONT FOG LAMP SYSTEM

FRONT FOG LAMP SYSTEM : System Description

INFOID:000000011280713

SYSTEM DIAGRAM

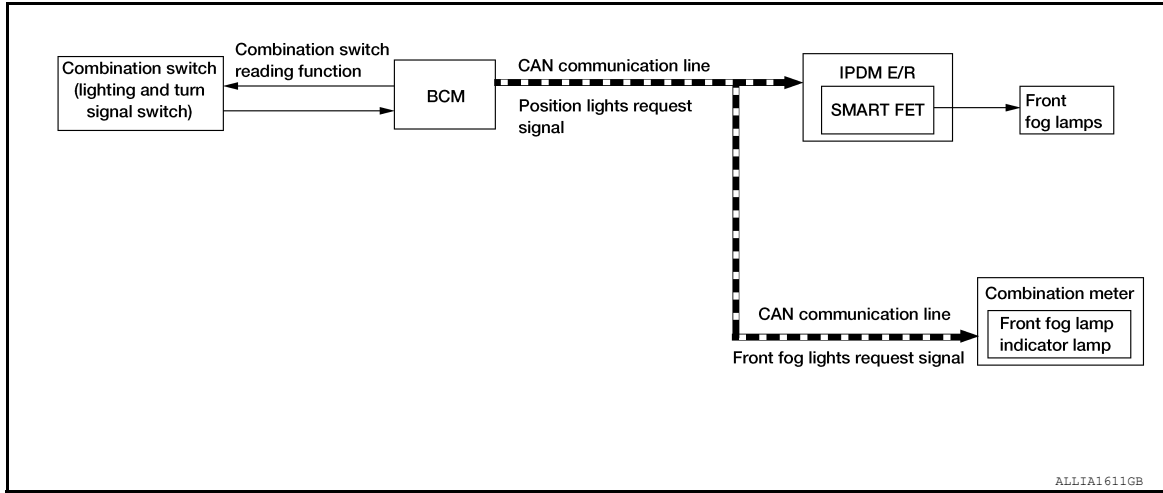

OUTLINE

Front fog lamp is controlled by combination switch reading function, front fog lamp control function of BCM, and smart FET function of IPDM E/R.

FRONT FOG LAMP OPERATION

- BCM detects the combination switch condition by the combination switch reading function.
- BCM transmits the front fog lights request signal to IPDM E/R and the combination meter via CAN communication according to the front fog lamp ON condition.

Front fog lamp ON condition:

- Front fog lamp switch ON, and any of the following conditions are satisfied (except for the high beam ON):
 - Lighting switch 2ND
 - Lighting switch AUTO and the ignition switch ON

IPDM E/R turns the front fog lamp ON according to the front fog lights request signal.

Combination meter turns the front fog lamp indicator lamp ON according to the front fog lights request signal.

FRONT FOG LAMP SYSTEM : Fail-Safe

INFOID:000000011280714

CAN COMMUNICATION CONTROL

When CAN communication with BCM is impossible, IPDM E/R performs fail-safe control. After CAN communication recovers normally, it also returns to normal control.

If no CAN communication is available with BCM

Control part	Fail-safe operation
Front fog lamp	Front fog lamp OFF

EXTERIOR LAMP BATTERY SAVER SYSTEM

A
B
C
D
E
F
G
H
I
J
K
EXL
M
N
O
P

EXTERIOR LAMP BATTERY SAVER SYSTEM : System Description

INFOID:000000011280715

SYSTEM DIAGRAM

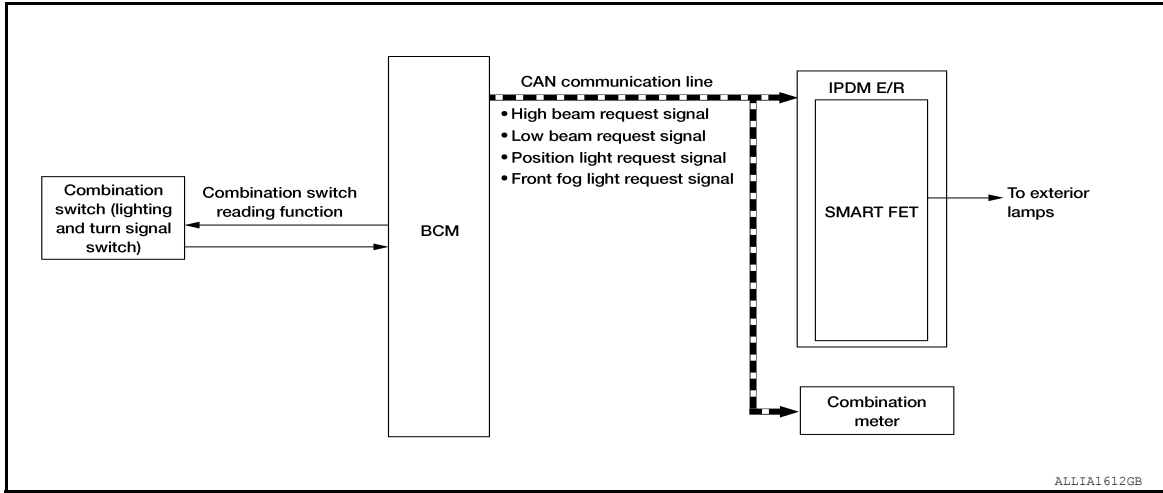

OUTLINE

- Exterior lamp battery saver system is controlled by each function of BCM and IPDM E/R.

Controlled by BCM:

- Combination switch reading function
- Headlamp control function
- Exterior lamp battery saver function

Controlled by IPDM E/R:

- BCM turns the exterior lamps* OFF after a period of time to prevent the battery from over-discharge when the ignition switch is turned OFF with the exterior lamps ON.

*: Headlamp (LO/HI), parking lamp, tail lamp, side marker lamp, license plate lamp and front fog lamp

EXTERIOR LAMP BATTERY SAVER ACTIVATION

BCM activates the timer and turns the exterior lamp OFF 5 minutes after the ignition switch is turned from ON → OFF with the exterior lamps ON.

NOTE:

- Headlamp control function turns the exterior lamps ON normally when the ignition switch is turned ACC or set the vehicle to READY (both before and after the exterior lamp battery saver is turned OFF).
- The timer starts at the time that the lighting switch is turned from OFF → 1ST or 2ND with the exterior lamps OFF.

DIAGNOSIS SYSTEM (BCM)

[HALOGEN HEADLAMP]

< SYSTEM DESCRIPTION >

DIAGNOSIS SYSTEM (BCM) WITH INTELLIGENT KEY

WITH INTELLIGENT KEY : CONSULT Function (BCM - COMMON ITEM) INFOID:0000000011392712

APPLICATION ITEM

CONSULT performs the following functions via CAN communication with BCM.

Direct Diagnostic Mode	Description
Ecu Identification	The BCM part number is displayed.
Self Diagnostic Result	The BCM self diagnostic results are displayed.
Data Monitor	The BCM input/output data is displayed in real time.
Active Test	The BCM activates outputs to test components.
Work support	The settings for BCM functions can be changed.
Configuration	<ul style="list-style-type: none"> • The vehicle specification can be read and saved. • The vehicle specification can be written when replacing BCM.
CAN Diag Support Mntr	The result of transmit/receive diagnosis of CAN communication is displayed.

SYSTEM APPLICATION

BCM can perform the following functions.

System	Sub System	Direct Diagnostic Mode						
		Ecu Identification	Self Diagnostic Result	Data Monitor	Active Test	Work support	Configuration	CAN Diag Support Mntr
Door lock	DOOR LOCK		x	x	x	x		
Rear window defogger	REAR DEFOGGER			x	x	x		
Warning chime	BUZZER			x	x			
Interior room lamp timer	INT LAMP			x	x	x		
Exterior lamp	HEADLAMP			x	x	x		
Wiper and washer	WIPER			x	x	x		
Turn signal and hazard warning lamps	FLASHER			x	x			
Intelligent Key system	INTELLIGENT KEY		x	x	x	x		
Combination switch	COMB SW			x				
BCM	BCM	x	x			x	x	x
Immobilizer	IMMU		x	x	x			
Interior room lamp battery saver	BATTERY SAVER			x	x			
Back door open	TRUNK			x				
Vehicle security system	THEFT ALM			x	x	x		
RAP system	RETAINED PWR			x				
Signal buffer system	SIGNAL BUFFER			x				
Air conditioner	AIR CONDITIONER				x			

WITH INTELLIGENT KEY : CONSULT Function (BCM - HEADLAMP)

INFOID:0000000011392713

DATA MONITOR

DIAGNOSIS SYSTEM (BCM)

[HALOGEN HEADLAMP]

< SYSTEM DESCRIPTION >

Monitor Item [Unit]	Description
PUSH SW [On/Off]	Indicates condition of push-button ignition switch.
ENGINE STATE [STOP/STALL/CRANK/RUN]	Indicates engine status received from ECM on CAN communication line.
VEH SPEED 1 [km/h]	Indicates vehicle speed signal received from ABS on CAN communication line.
TURN SIGNAL R [On/Off]	Indicates condition of combination switch.
TURN SIGNAL L [On/Off]	
TAIL LAMP SW [On/Off]	
HI BEAM SW [On/Off]	
HEAD LAMP SW [On/Off]	
LIGHT OFF SW [On/Off]	
PASSING SW [On/Off]	
AUTO LIGHT SW [On/Off]	
FR FOG SW [On/Off]	
DOOR SW-DR [On/Off]	
DOOR SW-AS [On/Off]	Indicates condition of front door switch RH.
DOOR SW-RR [On/Off]	Indicates condition of rear door switch RH.
DOOR SW-RL [On/Off]	Indicates condition of rear door switch LH.
DOOR SW-BK [On/Off]	Indicates condition of back door switch.
OPTI SEN (DTCT) [V]	Indicates outside brightness voltage signal from optical sensor.
OPTI SEN (FILT) [V]	Indicates outside brightness voltage signal from optical sensor filtered by BCM.
OPTICAL SENSOR [On/Off]	Indicates condition of optical sensor.

ACTIVE TEST

Test Item	Description
FR FOG LAMP	This test is able to check front fog lamp operation [On/Off].
STOP LAMP 1	This test is able to check rear combination lamp stop lamp operation [On/Off].
STOP LAMP 3	This test is able to check high-mounted stop lamp operation [On/Off].
DAYTIME RUNNING LIGHT	This test is able to check daytime running light operation [On/Off].
ILL DIM SIGNAL	This test is able to check illumination dimmer signal [On/Off].

WORK SUPPORT

Support Item	Setting	Description
TWILIGHT ON	MODE2*	Autolamp function ON.
	MODE1	Autolamp function OFF.
CUSTOM A/LIGHT SETTING	MODE4	Less sensitive than normal setting (turns ON later).
	MODE3	More sensitive than MODE2.
	MODE2	More sensitive than normal setting (turns ON earlier).
	MODE1*	Normal setting.

DIAGNOSIS SYSTEM (BCM)

< SYSTEM DESCRIPTION >

[HALOGEN HEADLAMP]

Support Item	Setting	Description
ILL DELAY SET	MODE 8	Autolamp delay timer.
	MODE 7	
	MODE 6	
	MODE 4	
	MODE 5	
	MODE 3	
	MODE 2	
	MODE 1*	

*: Initial setting

WITH INTELLIGENT KEY : CONSULT Function (BCM - FLASHER)

INFOID:0000000011392714

DATA MONITOR

Monitor Item [Unit]	Description
REQ SW -DR [On/Off]	Indicates condition of door request switch LH.
REQ SW -AS [On/Off]	Indicates condition of door request switch RH.
PUSH SW [On/Off]	Indicates condition of push-button ignition switch.
TURN SIGNAL R [On/Off]	Indicates condition of turn signal function of combination switch.
TURN SIGNAL L [On/Off]	
HAZARD SW [On/Off]	Indicates condition of hazard switch.
RKE-LOCK [On/Off]	Indicates condition of lock signal from Intelligent Key.
RKE-UNLOCK [On/Off]	Indicates condition of unlock signal from Intelligent Key.
RKE-PANIC [On/Off]	Indicates condition of panic alarm signal from Intelligent Key.

WORK SUPPORT

Support Item	Setting	Description
3-TIME FLASHER SETTING	On*	3-time flasher setting ON.
	Off	3-time flasher setting OFF.

*: Initial setting

WITHOUT INTELLIGENT KEY

WITHOUT INTELLIGENT KEY : CONSULT Function (BCM - COMMON ITEM)

INFOID:0000000011392715

APPLICATION ITEM

CONSULT performs the following functions via CAN communication with BCM.

Direct Diagnostic Mode	Description
Ecu Identification	The BCM part number is displayed.
Self Diagnostic Result	The BCM self diagnostic results are displayed.
Data Monitor	The BCM input/output data is displayed in real time.
Active Test	The BCM activates outputs to test components.
Work support	The settings for BCM functions can be changed.
Configuration	<ul style="list-style-type: none"> • The vehicle specification can be read and saved. • The vehicle specification can be written when replacing BCM.
CAN Diag Support Mntr	The result of transmit/receive diagnosis of CAN communication is displayed.

DIAGNOSIS SYSTEM (BCM)

[HALOGEN HEADLAMP]

< SYSTEM DESCRIPTION >

SYSTEM APPLICATION

BCM can perform the following functions.

System	Sub System	Direct Diagnostic Mode						
		Ecu Identification	Self Diagnostic Result	Data Monitor	Active Test	Work support	Configuration	CAN Diag Support Mntr
Door lock	DOOR LOCK			×	×	×		
Rear window defogger	REAR DEFOGGER			×	×	×		
Warning chime	BUZZER			×	×			
Interior room lamp timer	INT LAMP			×	×	×		
Remote keyless entry system	MULTI REMOTE ENT					×		
Exterior lamp	HEADLAMP			×	×			
Wiper and washer	WIPER			×	×	×		
Turn signal and hazard warning lamps	FLASHER			×	×			
Combination switch	COMB SW			×				
BCM	BCM	×	×			×	×	×
Immobilizer	IMMU		×		×			
Interior room lamp battery saver	BATTERY SAVER			×	×			
Back door open	TRUNK			×				
Vehicle security system	THEFT ALM			×	×	×		
RAP system	RETAINED PWR			×				
TPMS	AIR PRESSURE MONITOR		×	×	×	×		

WITHOUT INTELLIGENT KEY : CONSULT Function (BCM - HEADLAMP) INFOID:000000011393083

DATA MONITOR

Monitor Item [Unit]	Description
TURN SIGNAL R [On/Off]	Indicates condition of combination switch.
TURN SIGNAL L [On/Off]	
TAIL LAMP SW [On/Off]	
HI BEAM SW [On/Off]	
HEAD LAMP SW [On/Off]	
LIGHT OFF SW [On/Off]	
PASSING SW [On/Off]	
DOOR SW-DR [On/Off]	Indicates condition of front door switch LH.
DOOR SW-AS [On/Off]	Indicates condition of front door switch RH.
DOOR SW-RR [On/Off]	Indicates condition of rear door switch RH.
DOOR SW-RL [On/Off]	Indicates condition of rear door switch LH.
DOOR SW-BK [On/Off]	Indicates condition of back door switch.

ACTIVE TEST

DIAGNOSIS SYSTEM (BCM)

< SYSTEM DESCRIPTION >

[HALOGEN HEADLAMP]

Test Item	Description
DAYTIME RUNNING LIGHT	This test is able to check daytime running lamp operation [On/Off].
ILL DIM SIGNAL	This test is able to check head lamp illumination dimming operation [On/Off].

WITHOUT INTELLIGENT KEY : CONSULT Function (BCM - FLASHER)

INFOID:000000011393084

DATA MONITOR

Monitor Item [Unit]	Description
TURN SIGNAL R [On/Off]	Indicates condition of turn signal function of combination switch.
TURN SIGNAL L [On/Off]	
HAZARD SW [On/Off]	Indicates condition of hazard switch.
RKE-LOCK [On/Off]	Indicates condition of lock signal from Intelligent Key.
RKE-UNLOCK [On/Off]	Indicates condition of unlock signal from Intelligent Key.
RKE-PANIC [On/Off]	Indicates condition of panic alarm signal from Intelligent Key.

ACTIVE TEST

Test Item	Description
FLASHER	This test is able to check turn signal lamp operation [Off/LH/RH].

A
B
C
D
E
F
G
H
I
J
K
L
M
N
O
P

EXL

DIAGNOSIS SYSTEM (IPDM E/R)

< SYSTEM DESCRIPTION >

[HALOGEN HEADLAMP]

DIAGNOSIS SYSTEM (IPDM E/R)

CONSULT Function (IPDM E/R)

INFOID:000000011393085

APPLICATION ITEM

CONSULT performs the following functions via CAN communication with IPDM E/R.

Direct Diagnostic Mode	Description
ECU Identification	The IPDM E/R part number is displayed.
Self Diagnostic Result	The IPDM E/R self diagnostic results are displayed.
Data Monitor	The IPDM E/R input/output data is displayed in real time.
Active Test	The IPDM E/R activates outputs to test components.
CAN Diag Support Mntr	The result of transmit/receive diagnosis of CAN communication is displayed.

ECU IDENTIFICATION

The IPDM E/R part number is displayed.

SELF DIAGNOSTIC RESULT

Refer to [PCS-22. "DTC Index"](#).

DATA MONITOR

Monitor Item [Unit]	Description
REVERSE SIGNAL [Open/Close]	Indicates condition of transmission range switch R (Reverse) position.
IGN RELAY [Open/Close]	Indicates condition of ignition relay-1.
PUSH SW [Open/Close]	Indicates condition of push-button ignition switch.
INTERLOCK/PNP SW [Open/Close]	Indicates condition of transmission range switch P (Park) and N (Neutral) positions.
OIL PRESSURE SW [Open/Close]	Indicates condition of oil pressure switch.
HOOD SW [Open/Close]	Indicates condition of hood switch.
COMPRESSOR [OFF/ON]	Indicates condition of A/C compressor.
HORN RELAY [OFF/ ON]	Indicates condition of horn relay.
COOLING FAN [OFF/ON]	Indicates condition of cooling fan relay-1.
FRONT WIPER HI/LO RELAY [OFF/ON]	Indicates condition of front wiper high relay.
FRONT WIPER RELAY [OFF/ON]	Indicates condition of front wiper relay.
IGN RELAY OFF STATUS [OFF/ON]	Indicates condition of ignition relay-1 OFF status.
IGN RELAY ON STATUS [OFF/ON]	Indicates condition of ignition relay-1 ON status.
COOLING FAN RELAY 1 [OFF/ON]	Indicates condition of cooling fan relay-1.
STARTER RELAY [OFF/ON]	Indicates condition of starter relay.
COMP ECV DUTY [%]	Indicates condition of A/C compressor.
COOLING FAN RELAY 2 [%]	Indicates condition of cooling fan relay-2.
FR FOG LAMP LH [%]	Indicates condition of front fog lamp LH.
FR FOG LAMP RH [%]	Indicates condition of front fog lamp RH.
PARKING LAMP [%]	Indicates condition of parking lamp.
TAIL LAMP LH [%]	Indicates condition of tail lamp LH.
TAIL LAMP RH [%]	Indicates condition of tail lamp RH.
DAYTIME RUNNING LIGHT LH [%]	Indicates condition of daytime running light LH.
DAYTIME RUNNING LIGHT RH [%]	Indicates condition of daytime running light RH.
HEADLAMP (HI) LH [%]	Indicates condition of headlamp high beam LH.

DIAGNOSIS SYSTEM (IPDM E/R)

< SYSTEM DESCRIPTION >

[HALOGEN HEADLAMP]

Monitor Item [Unit]	Description	
HEADLAMP (HI) RH [%]	Indicates condition of headlamp high beam RH.	A
HEADLAMP (LO) LH [%]	Indicates condition of headlamp low beam LH.	
HEADLAMP (LO) RH [%]	Indicates condition of headlamp low beam RH.	B
A/C RELAY STUCK [NG/OK]	Indicates condition of A/C relay.	
A/C RELAY [Off/On]	Indicates condition of A/C relay.	
COMP ECV STATUS [NG/OK]	Indicates condition of A/C compressor.	C
VEHICLE SECURITY HORN [Off/On]	Indicates condition of horn relay.	
BATTERY CURRENT SENSOR [NG/OK]	Indicates condition of battery current sensor.	D
FRONT FOG LAMP [Off/On]	Indicates condition of front fog lamps.	
COMP ECV CURRENT [A]	Indicates condition of A/C compressor current.	
BATTERY VOLTAGE [V]	Indicates condition of battery voltage.	E
COOLING FAN DUTY [%]	Indicates condition of cooling fans.	
HOOD SW (CAN) [OPEN/CLOSE]	Indicates condition of hood switch.	F
FRONT WIPER [STOP/LOW/HIGH]	Indicates condition of front wiper motor.	
FR WIPER STOP POSITION [STOP P/ACTIVE P]	Indicates condition of front wiper motor stop.	
HEADLAMP (HI) [Off/On]	Indicates condition of headlamp high beams.	G
HEADLAMP (LO) [Off/On]	Indicates condition of headlamp low beams.	
IGNITION RELAY STATUS [Off/On]	Indicates condition of ignition relay-1.	
IGN RELAY MONITOR [Off/On]	Indicates condition of ignition relay-1 feedback.	H
IGNITION POWER SUPPLY [Off/On]	Indicates condition of ignition relay-1.	
INTERLOCK/PNP SW (CAN) [Off/On]	Indicates condition of transmission range switch P (Park) and N (Neutral) positions.	I
PUSH-BUTTON IGN SW (CAN) [Off/On]	Indicates condition of push-button ignition switch.	
TAIL LAMP [Off/On]	Indicates condition of tail lamps.	J
REVERSE SIGNAL (CAN) [Off/On]	Indicates condition of transmission range switch R (Reverse) position.	
ST&ST CONT RELAY STATUS [Off/ST R On]	Indicates condition of starter cut and starter relays.	K
STARTER MOTOR STATUS [Off/On]	Indicates condition of starter motor.	
STARTER RELAY (CAN) [LOW/HIGH]	Indicates condition of starter relay.	EXL
IPDM NOT SLEEP [NO RDY/RDY]	Indicates condition of IPDM E/R sleep status.	
AFTER COOLING TIME [No request/Request]	Indicates condition of cooling fan request.	
AFTER COOLING SPEED [%]	Indicates condition of cooling fans.	M
COOLING FAN TYPE [NISSAN/RENAULT]	Indicates cooling fan type.	
COMPRESSOR REQ1 [Off/On]	Indicates condition of A/C compressor request.	
VHCL SECURITY HORN REQ [Off/On]	Indicates condition of horn relay request.	N
DTRL REQ [Off/On]	Indicates condition of daytime running light request.	
SLEEP/WAKE UP [WAKEUP/SLEEP]	Indicates condition of IPDM E/R sleep/wake.	O
CRANKING ENABLE-TCM [NG/OK]	Indicates condition of crank enable from TCM.	
CRANKING ENABLE-ECM [NG/OK]	Indicates condition of crank enable from ECM.	
CAN DIAGNOSIS [NG/OK]	Indicates condition of CAN diagnosis.	P
FRONT FOG LAMP REQ [Off/On]	Indicates condition of front fog lamp request.	
HIGH BEAM REQ [Off/On]	Indicates condition of headlamp high beam request.	
HORN CHIRP [Off/On]	Indicates condition of horn relay request.	
COOLING FAN REQ [%]	Indicates condition of cooling fan request.	
ENGINE STATUS [STOP/RUN/IDLING]	Indicates condition of engine status.	

DIAGNOSIS SYSTEM (IPDM E/R)

[HALOGEN HEADLAMP]

< SYSTEM DESCRIPTION >

Monitor Item [Unit]	Description
TURN SIGNAL REQ [Off/LH/RH]	Indicates condition of turn signal request.
FR WIPER REQ [RETURN/LOW/HIGH]	Indicates condition of front wiper motor request.
SHIFT POSITION [P/R/N/D/L]	Indicates condition of transmission range switch positions.
LOW BEAM REQ [Off/On]	Indicates condition of headlamp low beam request.
POSITION LIGHT REQ [Off/On]	Indicates condition of parking lamp request.
COMPRESSOR REQ2 [Off/On]	Indicates condition of A/C compressor request.
IGNITION SW [Off/On]	Indicates condition of ignition switch.
VEHICLE SPEED (METER) [mph/km/h]	Indicates vehicle speed.
BAT DISCHARGE COUNT [0-100]	Indicates condition of battery discharge.
BATTERY STATUS [NG/OK]	Indicates battery status.

ACTIVE TEST

Test item	Description
HORN	This test is able to check horn operation [Off/On].
FRONT WIPER	This test is able to check wiper motor operation [Off/Low/High].
COMPRESSOR	This test is able to check A/C compressor operation [Off/On].
COOLING FAN (DUAL)	This test is able to check cooling fan operation [Off/LO/HI].
HEADLAMP (HI)	This test is able to check headlamp high beam operation [Off/3/5].
HEADLAMP (LO)	This test is able to check headlamp low beam operation [Off/3/5].
FRONT FOG LAMP	This test is able to check front fog lamp operation [Off/3/5].
DAYTIME RUNNING LAMP	This test is able to check daytime running lamp operation [Off/3/5].
PARKING LAMP	This test is able to check parking lamp operation [Off/3/5].
TAIL LAMP	This test is able to check tail lamp operation [Off/3/5].

CAN DIAG SUPPORT MNTR

Refer to [LAN-14, "CAN Diagnostic Support Monitor"](#).

ECU DIAGNOSIS INFORMATION

BCM, IPDM E/R

List of ECU Reference

INFOID:0000000011280723

ECU	Reference
BCM (with Intelligent Key system)	BCS-28, "Reference Value"
	BCS-46, "Fail Safe"
	BCS-46, "DTC Inspection Priority Chart"
	BCS-47, "DTC Index"
BCM (without Intelligent Key system)	BCS-96, "Reference Value"
	BCS-107, "Fail Safe"
	BCS-107, "DTC Inspection Priority Chart"
	BCS-108, "DTC Index"
IPDM E/R	PCS-14, "Reference Value".
	PCS-21, "Fail-safe"
	PCS-22, "DTC Index"

A
B
C
D
E
F
G
H
I
J
K
L
M
N
O
P

EXL

HEADLAMP

[HALOGEN HEADLAMP]

< WIRING DIAGRAM >

WIRING DIAGRAM

HEADLAMP

Wiring Diagram

INFOID:0000000011280724

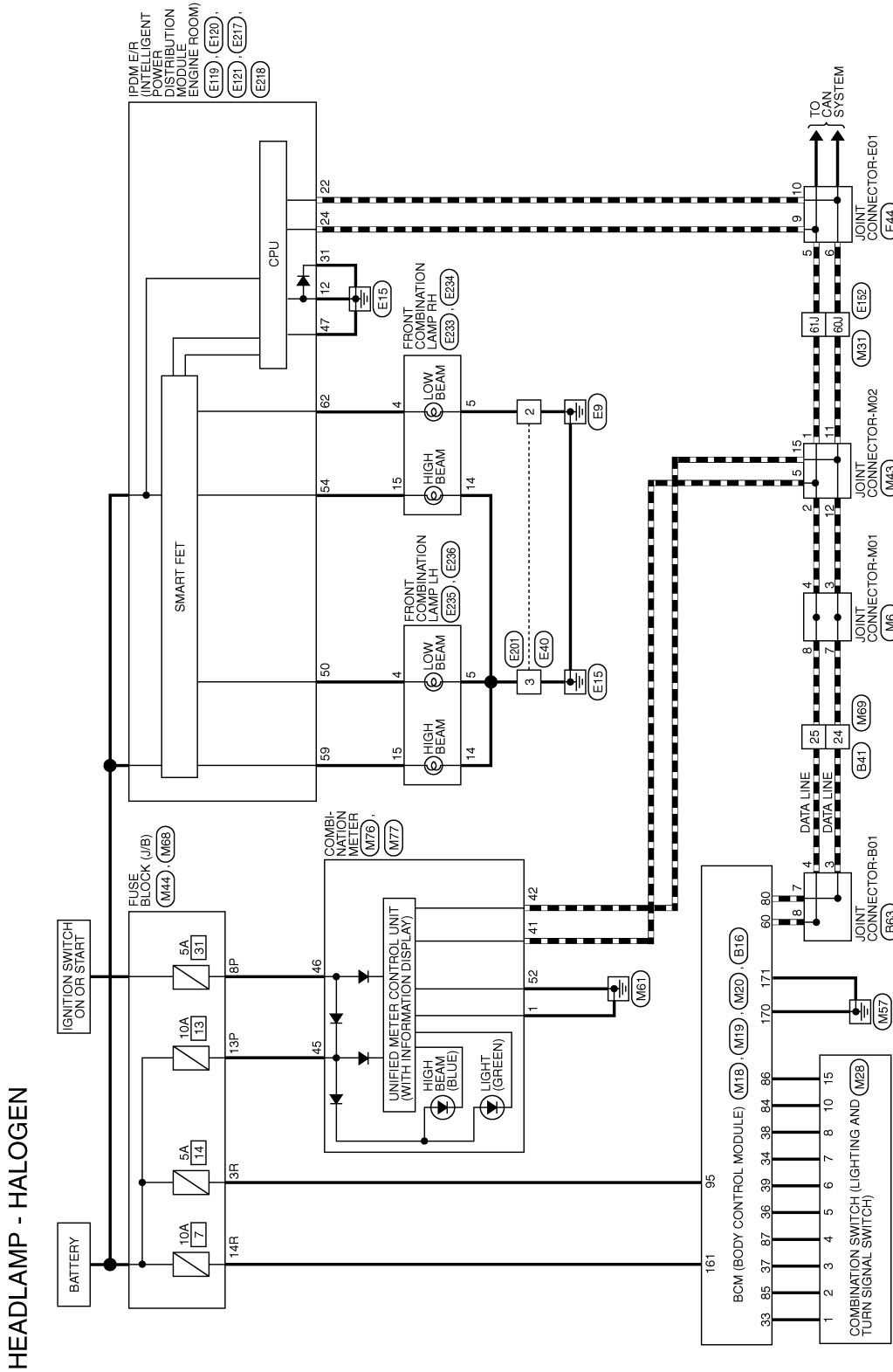

AALWA1050GB

HEADLAMP

< WIRING DIAGRAM >

[HALOGEN HEADLAMP]

HEADLAMP CONNECTORS - HALOGEN

Connector No.	M6
Connector Name	JOINT CONNECTOR-M01
Connector Color	GRAY

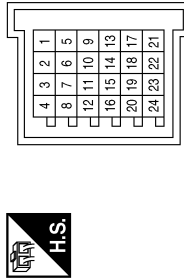

Terminal No.	Color of Wire	Signal Name
3	P	-
4	L	-
7	P	-
8	L	-

Connector No.	M18
Connector Name	BCM (BODY CONTROL MODULE)
Connector Color	GRAY

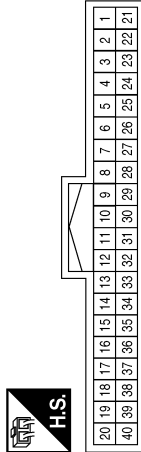

Terminal No.	Color of Wire	Signal Name
33	LG	ICSW 5
34	Y	O CSW 5
36	G	ICSW 3
37	GR	ICSW 4
38	V	ICSW 1
39	W	ICSW 2

Connector No.	M19
Connector Name	BCM (BODY CONTROL MODULE)
Connector Color	BLACK

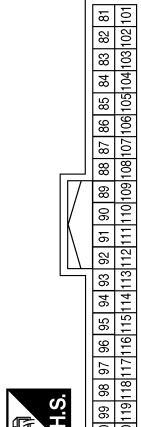

Terminal No.	Color of Wire	Signal Name
84	BR	O CSW 2
85	SB	O CSW 1
86	P	O CSW 3
87	BG	O CSW 4
95	V	I SHORTING PIN

Connector No.	M20
Connector Name	BCM (BODY CONTROL MODULE)
Connector Color	BROWN



Terminal No.	Color of Wire	Signal Name
161	W	I PWR ECU
170	B	I GND1
171	B	I GND2

Connector No.	M28
Connector Name	COMBINATION SWITCH (LIGHTING AND TURN SIGNAL SWITCH)
Connector Color	WHITE

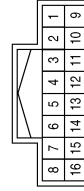

Terminal No.	Color of Wire	Signal Name
1	LG	-
2	SB	-
3	GR	-

Terminal No.	Color of Wire	Signal Name
4	BG	-
5	G	-
6	W	-
7	Y	-
8	V	-
10	BR	-
15	P	-

A
B
C
D
E
F
G
H
I
J
K
EXL
M
N
O
P

HEADLAMP

< WIRING DIAGRAM >

[HALOGEN HEADLAMP]

Connector No.	M31
Connector Name	WIRE TO WIRE
Connector Color	WHITE

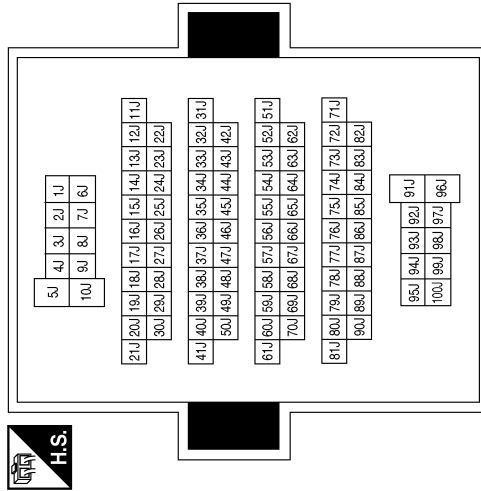

Terminal No.	Color of Wire	Signal Name
60J	P	-
61J	L	-

Connector No.	M43
Connector Name	JOINT CONNECTOR-M02
Connector Color	BLUE

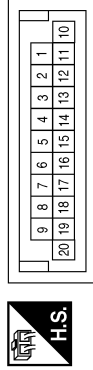

Terminal No.	Color of Wire	Signal Name
1	L	-
2	L	-
5	L	-
11	P	-
12	P	-
15	P	-

Connector No.	M44
Connector Name	FUSE BLOCK (J/B)
Connector Color	WHITE



Terminal No.	Color of Wire	Signal Name
8P	LA/BR	-
13P	LA/G	-

Connector No.	M68
Connector Name	FUSE BLOCK (J/B)
Connector Color	BROWN



Terminal No.	Color of Wire	Signal Name
3R	V	-
14R	W	-

Connector No.	M69
Connector Name	WIRE TO WIRE
Connector Color	WHITE

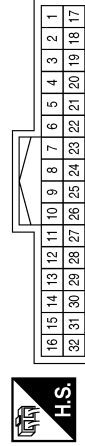

Terminal No.	Color of Wire	Signal Name
24	P	-
25	L	-

HEADLAMP

< WIRING DIAGRAM >

[HALOGEN HEADLAMP]

Connector No.	E40
Connector Name	WIRE TO WIRE
Connector Color	WHITE



Terminal No.	Color of Wire	Signal Name
2	GR	-
3	B	-

Connector No.	M77
Connector Name	COMBINATION METER
Connector Color	WHITE

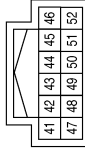

Terminal No.	Color of Wire	Signal Name
41	L	CAN-H
42	P	CAN-L
45	LA/G	BAT
46	LA/BR	IGN
52	B	G1

Connector No.	M76
Connector Name	COMBINATION METER
Connector Color	WHITE

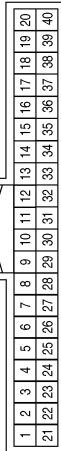

Terminal No.	Color of Wire	Signal Name
1	B	GND

Connector No.	E120
Connector Name	IPDM E/R (INTELLIGENT POWER DISTRIBUTION MODULE ENGINE ROOM)
Connector Color	GRAY

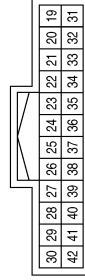

Connector No.	E119
Connector Name	IPDM E/R (INTELLIGENT POWER DISTRIBUTION MODULE ENGINE ROOM)
Connector Color	GRAY

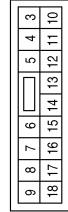

Terminal No.	Color of Wire	Signal Name
22	P	CAN-L
24	L	CAN-H
31	B	2ND SIGNAL GROUND

Connector No.	E44
Connector Name	JOINT CONNECTOR-E01
Connector Color	WHITE

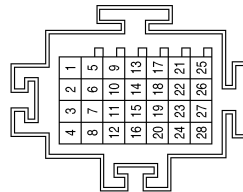

Terminal No.	Color of Wire	Signal Name
5	L	-
6	P	-
9	L	-
10	P	-

AALIA2976GB

A
B
C
D
E
F
G
H
I
J
K
L
M
N
O
P

EXL

HEADLAMP

< WIRING DIAGRAM >

[HALOGEN HEADLAMP]

Terminal No.	Color of Wire	Signal Name
60J	P	-
61J	L	-

Connector No.	E152
Connector Name	WIRE TO WIRE
Connector Color	WHITE

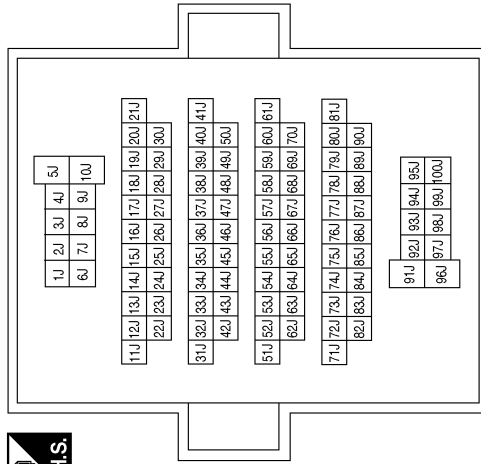

Connector No.	E121
Connector Name	IPDM E/R (INTELLIGENT POWER DISTRIBUTION MODULE ENGINE ROOM)
Connector Color	RED



Terminal No.	Color of Wire	Signal Name
47	B	POWER GROUND

Connector No.	E218
Connector Name	IPDM E/R (INTELLIGENT POWER DISTRIBUTION MODULE ENGINE ROOM)
Connector Color	WHITE

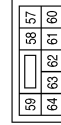

Connector No.	E217
Connector Name	IPDM E/R (INTELLIGENT POWER DISTRIBUTION MODULE ENGINE ROOM)
Connector Color	BROWN



Connector No.	E201
Connector Name	WIRE TO WIRE
Connector Color	WHITE



Terminal No.	Color of Wire	Signal Name
59	G	O LIGHT HBEAM LH
62	SB	O LIGHT LBEAM RH

Terminal No.	Color of Wire	Signal Name
50	L	O LIGHT LBEAM LH
54	LG	O LIGHT HBEAM RH

Terminal No.	Color of Wire	Signal Name
2	B	-
3	B	-

AALIA2977GB

HEADLAMP

< WIRING DIAGRAM >

[HALOGEN HEADLAMP]

Connector No.	E235
Connector Name	FRONT COMBINATION LAMP LH
Connector Color	BLACK



Terminal No.	Color of Wire	Signal Name
4	L	-
5	B	-

Connector No.	E234
Connector Name	FRONT COMBINATION LAMP RH
Connector Color	GRAY



Terminal No.	Color of Wire	Signal Name
14	B	-
15	LG	-

Connector No.	E233
Connector Name	FRONT COMBINATION LAMP RH
Connector Color	BLACK



Terminal No.	Color of Wire	Signal Name
4	SB	-
5	B	-

Connector No.	B41
Connector Name	WIRE TO WIRE
Connector Color	WHITE

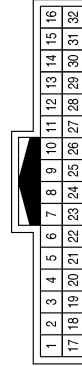

Terminal No.	Color of Wire	Signal Name
24	P	-
25	L	-

Connector No.	B16
Connector Name	BCM (BODY CONTROL MODULE)
Connector Color	GREEN



Terminal No.	Color of Wire	Signal Name
60	L	CAN-H
80	P	CAN-L

Connector No.	E236
Connector Name	FRONT COMBINATION LAMP LH
Connector Color	GRAY



Terminal No.	Color of Wire	Signal Name
14	B	-
15	G	-

AALIA2988GB

A
B
C
D
E
F
G
H
I
J
K
EXL
M
N
O
P

HEADLAMP

< WIRING DIAGRAM >

[HALOGEN HEADLAMP]

Connector No.	B63
Connector Name	JOINT CONNECTOR-B01
Connector Color	GRAY

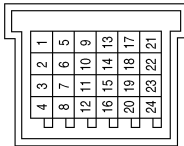

Terminal No.	Color of Wire	Signal Name
3	P	-
4	L	-
7	P	-
8	L	-

AALIA2137GB

DAYTIME RUNNING LIGHT SYSTEM

< WIRING DIAGRAM >

[HALOGEN HEADLAMP]

DAYTIME RUNNING LIGHT SYSTEM

Wiring Diagram

INFOID:000000011280725

DAYTIME RUNNING LIGHT SYSTEM

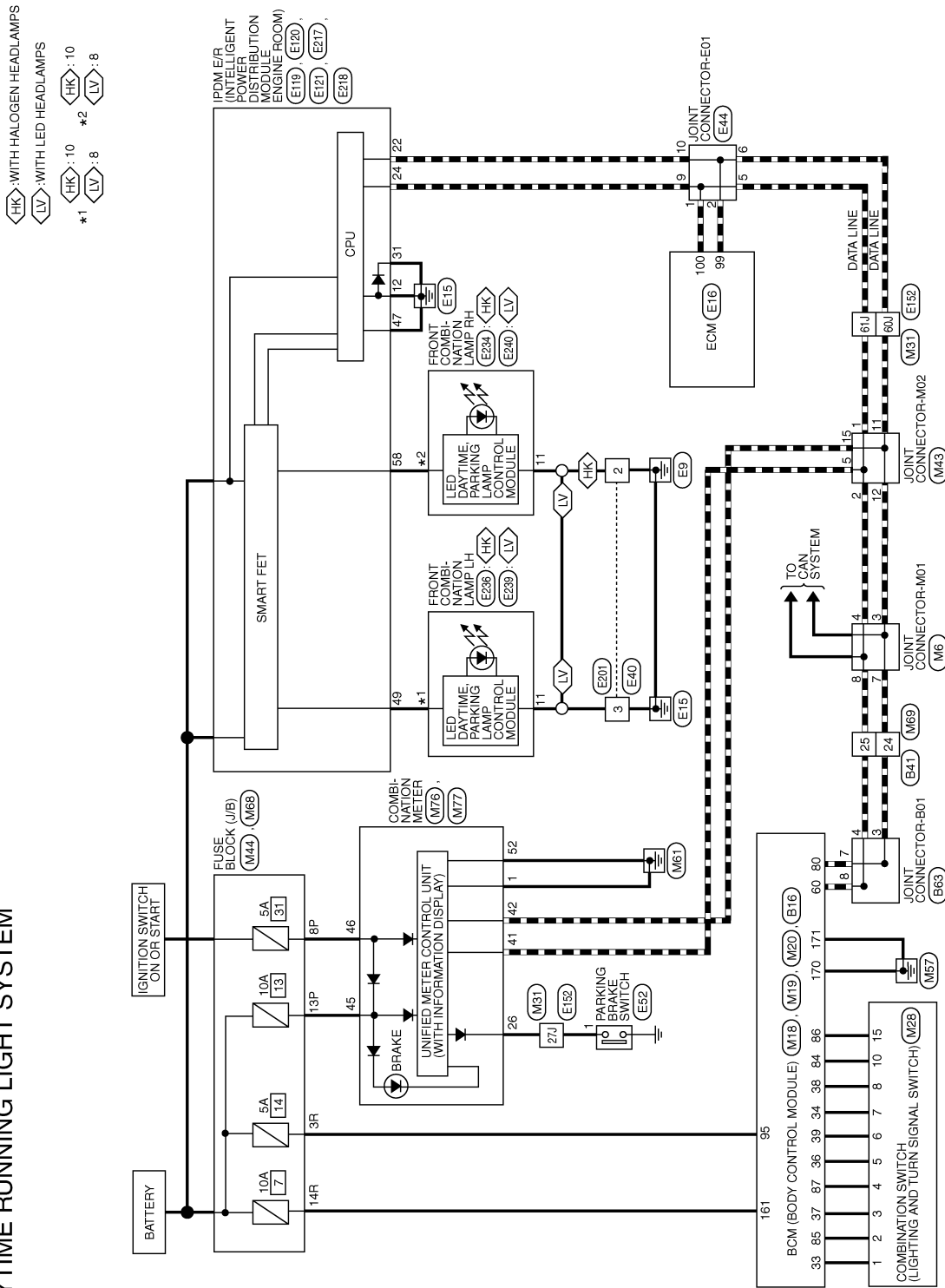

◻ HK ◻ : WITH HALOGEN HEADLAMPS
 ◻ LV ◻ : WITH LED HEADLAMPS
 *1 ◻ HK ◻ : 10
 *2 ◻ LV ◻ : 8

A
B
C
D
E
F
G
H
I
J
K
L
M
N
O
P

EXL

AALWA1045GB

DAYTIME RUNNING LIGHT SYSTEM

< WIRING DIAGRAM >

[HALOGEN HEADLAMP]

DAYTIME RUNNING LIGHT SYSTEM CONNECTORS

Connector No.	M6
Connector Name	JOINT CONNECTOR-M01
Connector Color	GRAY

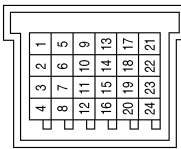

Terminal No.	Color of Wire	Signal Name
3	P	-
4	L	-
7	P	-
8	L	-

Connector No.	M18
Connector Name	BCM (BODY CONTROL MODULE)
Connector Color	GRAY

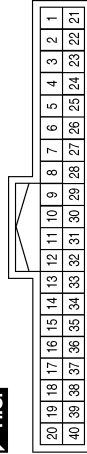

Terminal No.	Color of Wire	Signal Name
33	LG	I CSW 5
34	Y	O CSW 5
36	G	I CSW 3
37	GR	I CSW 4
38	V	I CSW 1
39	W	I CSW 2

Connector No.	M19
Connector Name	BCM (BODY CONTROL MODULE)
Connector Color	BLACK

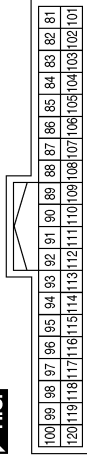

Terminal No.	Color of Wire	Signal Name
84	BR	O CSW 2
85	SB	O CSW 1
86	P	O CSW 3
87	BG	O CSW 4
95	V	I SHORTING PIN

Connector No.	M20
Connector Name	BCM (BODY CONTROL MODULE)
Connector Color	BROWN



Terminal No.	Color of Wire	Signal Name
161	W	I PWR ECU
170	B	I GND1
171	B	I GND2

Connector No.	M28
Connector Name	COMBINATION SWITCH (LIGHTING AND TURN SIGNAL SWITCH)
Connector Color	WHITE

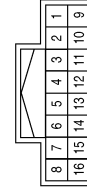

Terminal No.	Color of Wire	Signal Name
1	LG	-
2	SB	-
3	GR	-
4	BG	-

Terminal No.	Color of Wire	Signal Name
5	G	-
6	W	-
7	Y	-
8	V	-
10	BR	-
15	P	-

DAYTIME RUNNING LIGHT SYSTEM

< WIRING DIAGRAM >

[HALOGEN HEADLAMP]

Connector No.	M31
Connector Name	WIRE TO WIRE
Connector Color	WHITE

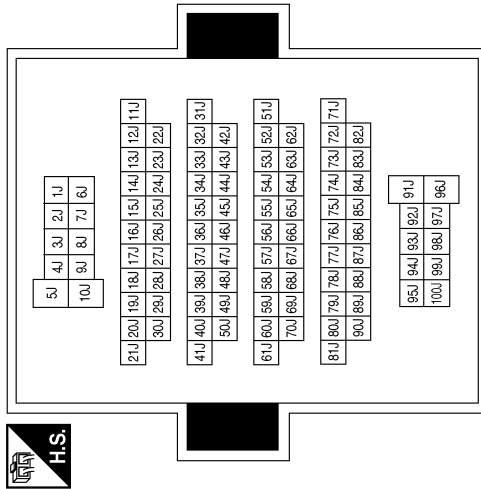

Connector No.	M43
Connector Name	JOINT CONNECTOR-M02
Connector Color	BLUE

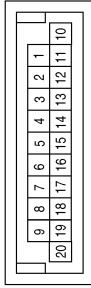

Terminal No.	Color of Wire	Signal Name
1	L	-
2	L	-
5	L	-
11	P	-
12	P	-
15	P	-

Connector No.	M44
Connector Name	FUSE BLOCK (J/B)
Connector Color	WHITE



Terminal No.	Color of Wire	Signal Name
8P	LA/BR	-
13P	LA/G	-

Terminal No.	Color of Wire	Signal Name
27J	G	-
60J	P	-
61J	L	-

Connector No.	M68
Connector Name	FUSE BLOCK (J/B)
Connector Color	BROWN



Terminal No.	Color of Wire	Signal Name
3R	V	-
14R	W	-

Connector No.	M69
Connector Name	WIRE TO WIRE
Connector Color	WHITE

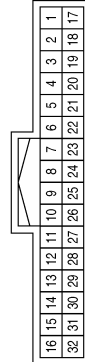

Terminal No.	Color of Wire	Signal Name
24	P	-
25	L	-

Connector No.	M76
Connector Name	COMBINATION METER
Connector Color	WHITE

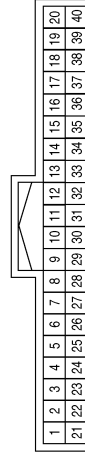

Terminal No.	Color of Wire	Signal Name
1	B	GND
26	G	PBK SW

AALIA2954GB

A
B
C
D
E
F
G
H
I
J
K
L
M
N
O
P

EXL

DAYTIME RUNNING LIGHT SYSTEM

< WIRING DIAGRAM >

[HALOGEN HEADLAMP]

Connector No.	E40
Connector Name	WIRE TO WIRE
Connector Color	WHITE



Terminal No.	Color of Wire	Signal Name
2	GR	-
3	B	-

Connector No.	E16
Connector Name	ECM
Connector Color	BLACK

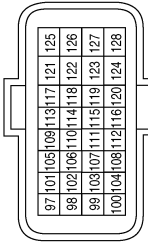

Terminal No.	Color of Wire	Signal Name
99	P	CAN-L
100	L	CAN-H

Connector No.	M77
Connector Name	COMBINATION METER
Connector Color	WHITE

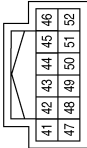

Terminal No.	Color of Wire	Signal Name
41	L	CAN-H
42	P	CAN-L
45	LA/G	BAT
46	LA/BR	IGN
52	B	G1

Connector No.	E119
Connector Name	IPDM E/R (INTELLIGENT POWER DISTRIBUTION MODULE ENGINE ROOM)
Connector Color	GRAY

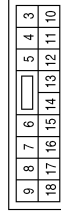

Connector No.	E52
Connector Name	PARKING BRAKE SWITCH
Connector Color	BLACK



Terminal No.	Color of Wire	Signal Name
12	B	SIGNAL GROUND

Connector No.	E44
Connector Name	JOINT CONNECTOR-E01
Connector Color	WHITE

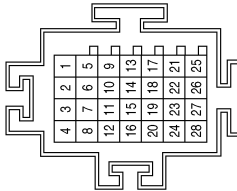

Terminal No.	Color of Wire	Signal Name
1	L	-
2	P	-
5	L	-
6	P	-
9	L	-
10	P	-

AALIA2955GB

DAYTIME RUNNING LIGHT SYSTEM

< WIRING DIAGRAM >

[HALOGEN HEADLAMP]

Connector No.	E121
Connector Name	IPDM E/R (INTELLIGENT POWER DISTRIBUTION MODULE ENGINE ROOM)
Connector Color	RED



Terminal No.	Color of Wire	Signal Name
47	B	POWER GROUND

Connector No.	E120
Connector Name	IPDM E/R (INTELLIGENT POWER DISTRIBUTION MODULE ENGINE ROOM)
Connector Color	GRAY

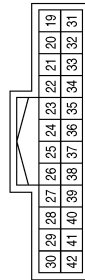

Terminal No.	Color of Wire	Signal Name
22	P	CAN-L
24	L	CAN-H
31	B	2ND SIGNAL GROUND

Connector No.	E201
Connector Name	WIRE TO WIRE
Connector Color	WHITE



Terminal No.	Color of Wire	Signal Name
2	B	-
3	B	-

Terminal No.	Color of Wire	Signal Name
27J	G	-
60J	P	-
61J	L	-

Connector No.	E152
Connector Name	WIRE TO WIRE
Connector Color	WHITE

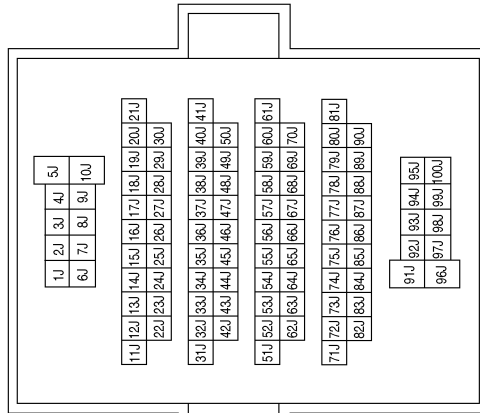

AALIA2956GB

A
B
C
D
E
F
G
H
I
J
K
L
M
N
O
P

EXL

DAYTIME RUNNING LIGHT SYSTEM

< WIRING DIAGRAM >

[HALOGEN HEADLAMP]

Connector No.	E234
Connector Name	FRONT COMBINATION LAMP RH (WITH HALOGEN HEADLAMPS)
Connector Color	GRAY



Terminal No.	Color of Wire	Signal Name
10	R	-
11	GR	-

Connector No.	E218
Connector Name	IPDM E/R (INTELLIGENT POWER DISTRIBUTION MODULE ENGINE ROOM)
Connector Color	WHITE

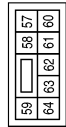

Terminal No.	Color of Wire	Signal Name
58	R	O LIGHT DTRL RH

Connector No.	E217
Connector Name	IPDM E/R (INTELLIGENT POWER DISTRIBUTION MODULE ENGINE ROOM)
Connector Color	BROWN



Terminal No.	Color of Wire	Signal Name
49	R	O LIGHT DTRL LH

Connector No.	E240
Connector Name	FRONT COMBINATION LAMP RH (WITH LED HEADLAMPS)
Connector Color	BLACK

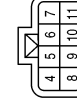

Terminal No.	Color of Wire	Signal Name
8	R	-
11	B	-

Connector No.	E239
Connector Name	FRONT COMBINATION LAMP LH (WITH LED HEADLAMPS)
Connector Color	BLACK

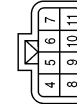

Terminal No.	Color of Wire	Signal Name
8	R	-
11	B	-

Connector No.	E236
Connector Name	FRONT COMBINATION LAMP LH (WITH HALOGEN HEADLAMPS)
Connector Color	GRAY



Terminal No.	Color of Wire	Signal Name
10	R	-
11	GR	-

AALIA21256B

DAYTIME RUNNING LIGHT SYSTEM

< WIRING DIAGRAM >

[HALOGEN HEADLAMP]

Connector No.	B63
Connector Name	JOINT CONNECTOR-B01
Connector Color	GRAY

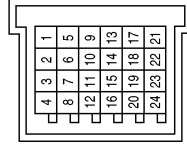

Terminal No.	Color of Wire	Signal Name
3	P	-
4	L	-
7	P	-
8	L	-

Connector No.	B41
Connector Name	WIRE TO WIRE
Connector Color	WHITE

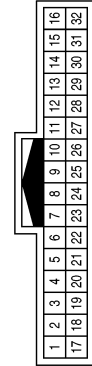

Terminal No.	Color of Wire	Signal Name
24	P	-
25	L	-

Connector No.	B16
Connector Name	BCM (BODY CONTROL MODULE)
Connector Color	GREEN

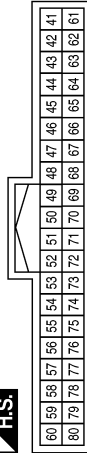

Terminal No.	Color of Wire	Signal Name
60	L	CAN-H
80	P	CAN-L

A
B
C
D
E
F
G
H
I
J
K
EXL
M
N
O
P

AALIA2126GB

AUTO LIGHT SYSTEM

[HALOGEN HEADLAMP]

< WIRING DIAGRAM >

AUTO LIGHT SYSTEM

Wiring Diagram

INFOID:000000011280726

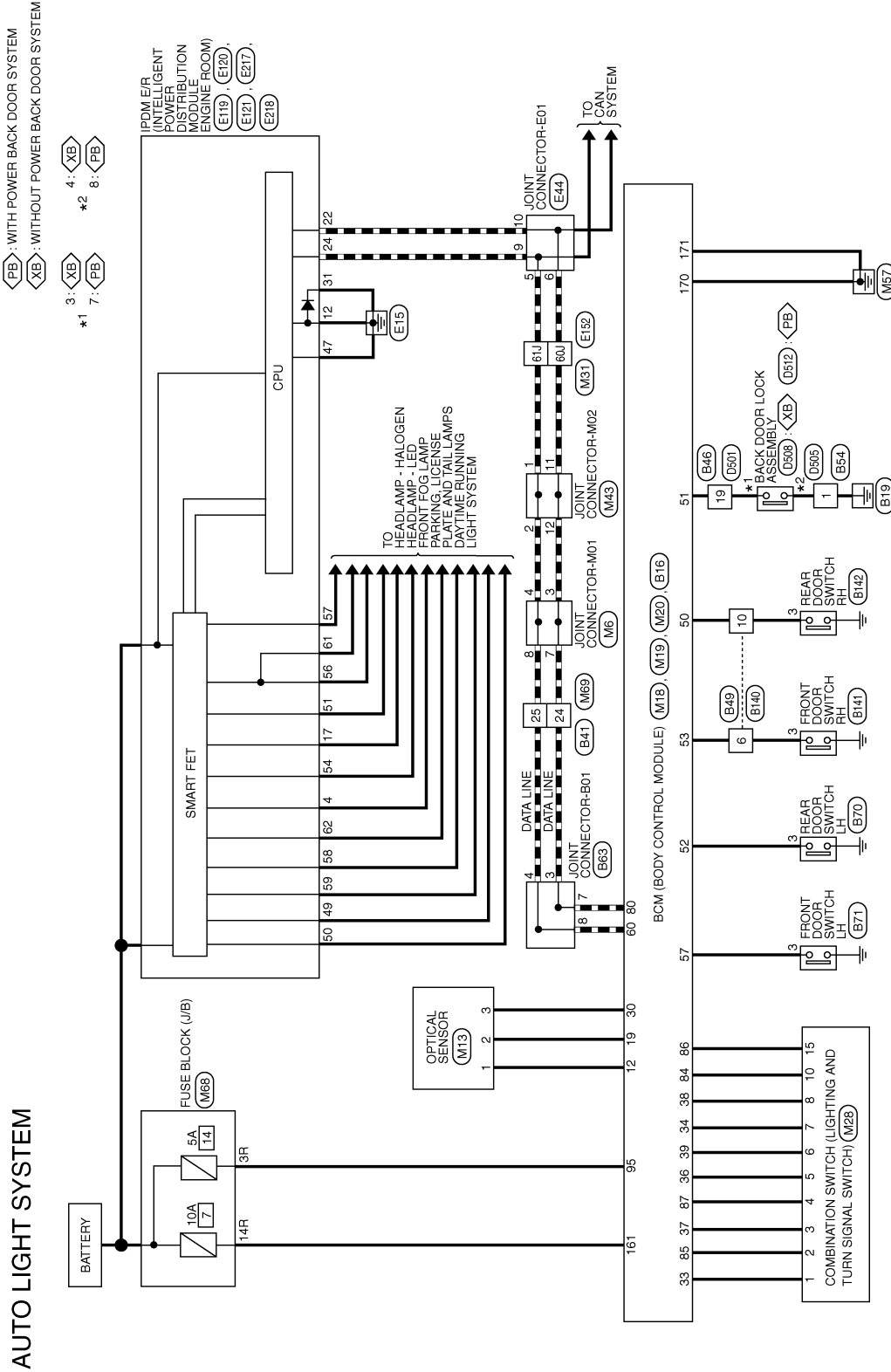

AALWA1043GB

AUTO LIGHT SYSTEM CONNECTORS

Connector No.	M6
Connector Name	JOINT CONNECTOR-M01
Connector Color	GRAY

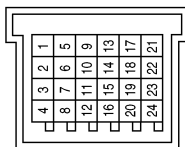

Terminal No.	Color of Wire	Signal Name
3	P	-
4	L	-
7	P	-
8	L	-

Connector No.	M13
Connector Name	OPTICAL SENSOR
Connector Color	WHITE



Terminal No.	Color of Wire	Signal Name
1	W	-
2	LG	-
3	V	-

Connector No.	M18
Connector Name	BCM (BODY CONTROL MODULE)
Connector Color	GRAY



Terminal No.	Color of Wire	Signal Name
12	W	O PWR AUTOLIGHT SENSOR
19	LG	I AUTOLIGHT SENSOR
30	V	O GND AUTOLIGHT SENSOR
33	LG	I CSW 5
34	Y	O CSW 5
36	G	I CSW 3
37	GR	I CSW 4
38	V	I CSW 1
39	W	I CSW 2

Connector No.	M19
Connector Name	BCM (BODY CONTROL MODULE)
Connector Color	BLACK

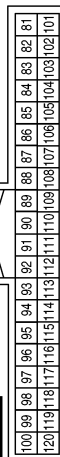

Terminal No.	Color of Wire	Signal Name
84	BR	O CSW 2
85	SB	O CSW 1
86	P	O CSW 3
87	BG	O CSW 4
95	V	I SHORTING PIN

Connector No.	M20
Connector Name	BCM (BODY CONTROL MODULE)
Connector Color	BROWN



Terminal No.	Color of Wire	Signal Name
161	W	I PWR ECU
170	B	I GND1
171	B	I GND2

AALIA2112GB

A B C D E F G H I J K L M N O P

EXL

AUTO LIGHT SYSTEM

< WIRING DIAGRAM >

[HALOGEN HEADLAMP]

Connector No.	M43
Connector Name	JOINT CONNECTOR-M02
Connector Color	BLUE

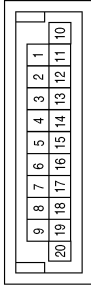

Terminal No.	Color of Wire	Signal Name
1	L	-
2	L	-
11	P	-
12	P	-

Connector No.	M31
Connector Name	WIRE TO WIRE
Connector Color	WHITE

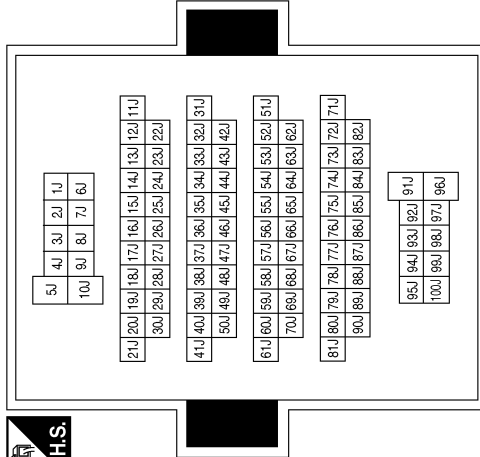

Terminal No.	Color of Wire	Signal Name
60J	P	-
61J	L	-

Connector No.	M28
Connector Name	COMBINATION SWITCH (LIGHTING AND TURN SIGNAL SWITCH)
Connector Color	WHITE

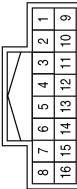

Terminal No.	Color of Wire	Signal Name
1	LG	-
2	SB	-
3	GR	-
4	BG	-
5	G	-
6	W	-
7	Y	-
8	V	-
10	BR	-
15	P	-

Connector No.	M68
Connector Name	FUSE BLOCK (J/B)
Connector Color	BROWN



Terminal No.	Color of Wire	Signal Name
3R	V	-
14R	W	-

Connector No.	M69
Connector Name	WIRE TO WIRE
Connector Color	WHITE

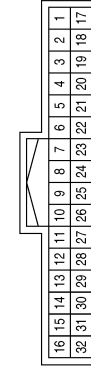

Terminal No.	Color of Wire	Signal Name
24	P	-
25	L	-

AUTO LIGHT SYSTEM

< WIRING DIAGRAM >

[HALOGEN HEADLAMP]

Connector No.	E44
Connector Name	JOINT CONNECTOR-E01
Connector Color	WHITE

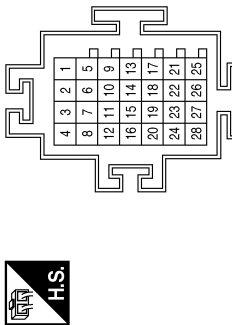

Terminal No.	Color of Wire	Signal Name
5	L	-
6	P	-
9	L	-
10	P	-

Connector No.	E121
Connector Name	IPDM E/R (INTELLIGENT POWER DISTRIBUTION MODULE ENGINE ROOM)
Connector Color	RED



Terminal No.	Color of Wire	Signal Name
47	B	POWER GROUND

Connector No.	E119
Connector Name	IPDM E/R (INTELLIGENT POWER DISTRIBUTION MODULE ENGINE ROOM)
Connector Color	GRAY

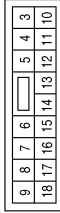

Terminal No.	Color of Wire	Signal Name
4	Y	O LIGHT POSITION REAR LH
12	B	SIGNAL GROUND
17	W	O LIGHT POSITION REAR RH

Connector No.	E152
Connector Name	WIRE TO WIRE
Connector Color	WHITE

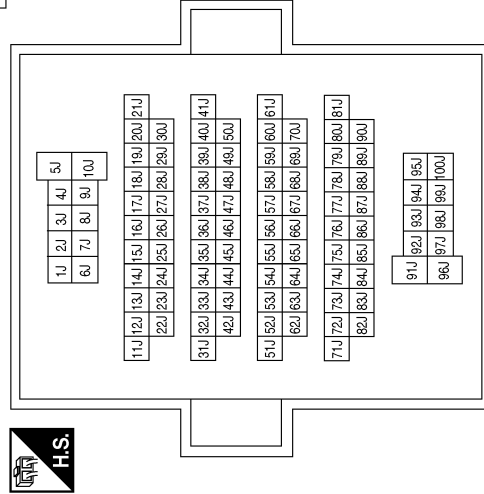

Connector No.	E120
Connector Name	IPDM E/R (INTELLIGENT POWER DISTRIBUTION MODULE ENGINE ROOM)
Connector Color	GRAY

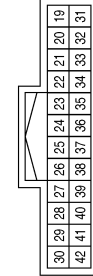

Terminal No.	Color of Wire	Signal Name
22	P	CAN-L
24	L	CAN-H
31	B	2ND SIGNAL GROUND

Terminal No.	Color of Wire	Signal Name
60J	P	-
61J	L	-

A
B
C
D
E
F
G
H
I
J
K
EXL
M
N
O
P

AUTO LIGHT SYSTEM

< WIRING DIAGRAM >

[HALOGEN HEADLAMP]

Connector No.	B16
Connector Name	BCM (BODY CONTROL MODULE)
Connector Color	GREEN

60	59	58	57	56	55	54	53	52	51	50	49	48	47	46	45	44	43	42	41	
80	79	78	77	76	75	74	73	72	71	70	69	68	67	66	65	64	63	62	61	

Terminal No.	Color of Wire	Signal Name
50	W	I RR DOOR SW
51	LG	I TGATE SW
52	R	I RL DOOR SW
53	SB	I AS DOOR2 SW
57	SB	I DR DOOR2 SW
60	L	CAN-H
80	P	CAN-L

Connector No.	E218
Connector Name	IPDM E/R (INTELLIGENT POWER DISTRIBUTION MODULE ENGINE ROOM)
Connector Color	WHITE

59	58	57	64	63	62	61	60
----	----	----	----	----	----	----	----

Terminal No.	Color of Wire	Signal Name
57	W	O LIGHT FR FOG LAMPS RH
58	R	O LIGHT DTRL RH
59	G	O LIGHT HBEAM LH
61	GR	O LIGHT CLEARANCE FR RH
62	SB	O LIGHT LBEAM RH

Connector No.	E217
Connector Name	IPDM E/R (INTELLIGENT POWER DISTRIBUTION MODULE ENGINE ROOM)
Connector Color	BROWN

51	50	49	56	55	54	53	52
----	----	----	----	----	----	----	----

Terminal No.	Color of Wire	Signal Name
49	R	O LIGHT DTRL LH
50	L	O LIGHT LBEAM LH
51	V	O LIGHT FR FOG LAMPS LH
54	LG	O LIGHT HBEAM RH
56	BG	O LIGHT CLEARANCE FR LH

Connector No.	B49
Connector Name	WIRE TO WIRE
Connector Color	WHITE

1	2	3	4	5	6	7	8	9	10	11	12
---	---	---	---	---	---	---	---	---	----	----	----

Terminal No.	Color of Wire	Signal Name
6	SB	—
10	W	—

Connector No.	B46
Connector Name	WIRE TO WIRE
Connector Color	WHITE

1	2	3	4	5	6	7	8	9	10	11	12	13	14	15	16
17	18	19	20	21	22	23	24	25	26	27	28	29	30	31	32

Terminal No.	Color of Wire	Signal Name
19	LG	—

Connector No.	B41
Connector Name	WIRE TO WIRE
Connector Color	WHITE

1	2	3	4	5	6	7	8	9	10	11	12	13	14	15	16
17	18	19	20	21	22	23	24	25	26	27	28	29	30	31	32

Terminal No.	Color of Wire	Signal Name
24	P	—
25	L	—

AALIA2115GB

AUTO LIGHT SYSTEM

< WIRING DIAGRAM >

[HALOGEN HEADLAMP]

Connector No.	B70
Connector Name	REAR DOOR SWITCH LH
Connector Color	WHITE

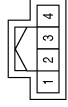

Terminal No.	Color of Wire	Signal Name
3	R	-

Connector No.	B63
Connector Name	JOINT CONNECTOR-B01
Connector Color	GRAY

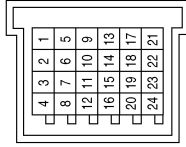

Terminal No.	Color of Wire	Signal Name
3	P	-
4	L	-
7	P	-
8	L	-

Connector No.	B54
Connector Name	WIRE TO WIRE
Connector Color	WHITE



Terminal No.	Color of Wire	Signal Name
1	B	-

Connector No.	B141
Connector Name	FRONT DOOR SWITCH RH
Connector Color	WHITE

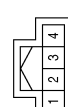

Terminal No.	Color of Wire	Signal Name
3	GR	-

Connector No.	B140
Connector Name	WIRE TO WIRE
Connector Color	WHITE

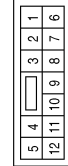

Terminal No.	Color of Wire	Signal Name
6	GR	-
10	W	-

Connector No.	B71
Connector Name	FRONT DOOR SWITCH LH
Connector Color	WHITE



Terminal No.	Color of Wire	Signal Name
3	SB	-

AALIA2116GB

A
B
C
D
E
F
G
H
I
J
K
EXL
M
N
O
P

AUTO LIGHT SYSTEM

< WIRING DIAGRAM >

[HALOGEN HEADLAMP]

Connector No.	D505
Connector Name	WIRE TO WIRE
Connector Color	WHITE



Terminal No.	Color of Wire	Signal Name
1	B	-

Connector No.	D501
Connector Name	WIRE TO WIRE
Connector Color	WHITE



Terminal No.	Color of Wire	Signal Name
19	W	-

Connector No.	B142
Connector Name	REAR DOOR SWITCH RH
Connector Color	WHITE

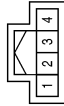

Terminal No.	Color of Wire	Signal Name
3	W	-

Connector No.	D512
Connector Name	BACK DOOR LOCK ASSEMBLY (WITH POWER BACK DOOR SYSTEM)
Connector Color	WHITE

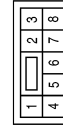

Terminal No.	Color of Wire	Signal Name
7	W	-
8	B	-

Connector No.	D508
Connector Name	BACK DOOR LOCK ASSEMBLY (WITHOUT POWER BACK DOOR SYSTEM)
Connector Color	WHITE



Terminal No.	Color of Wire	Signal Name
3	W	-
4	GR	-

AALIA2117GB

FRONT FOG LAMP SYSTEM

< WIRING DIAGRAM >

[HALOGEN HEADLAMP]

FRONT FOG LAMP SYSTEM

Wiring Diagram

INFOID:000000011280727

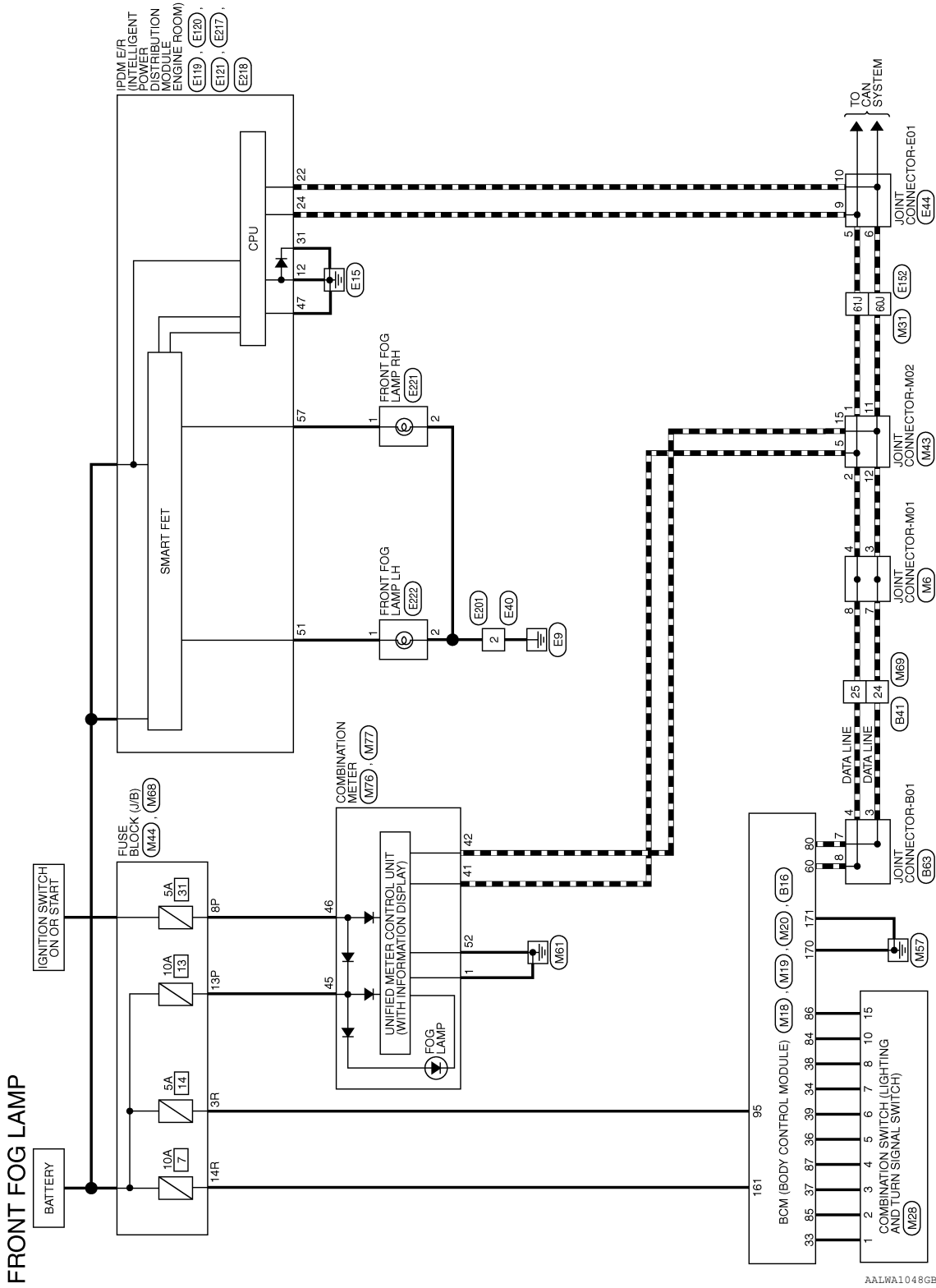

AALWA1048GB

A
B
C
D
E
F
G
H
I
J
K
EXL
M
N
O
P

FRONT FOG LAMP SYSTEM

[HALOGEN HEADLAMP]

< WIRING DIAGRAM >

FRONT FOG LAMP CONNECTORS

Connector No.	M6
Connector Name	JOINT CONNECTOR-M01
Connector Color	GRAY

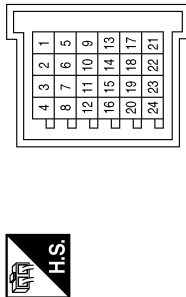

Terminal No.	Color of Wire	Signal Name
3	P	-
4	L	-
7	P	-
8	L	-

Connector No.	M18
Connector Name	BCM (BODY CONTROL MODULE)
Connector Color	GRAY

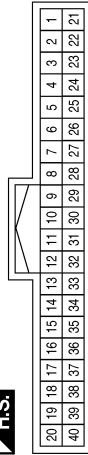

Terminal No.	Color of Wire	Signal Name
33	LG	I CSW 5
34	Y	O CSW 5
36	G	I CSW 3
37	GR	I CSW 4
38	V	I CSW 1
39	W	I CSW 2

Connector No.	M19
Connector Name	BCM (BODY CONTROL MODULE)
Connector Color	BLACK

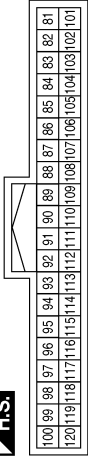

Terminal No.	Color of Wire	Signal Name
84	BR	O CSW 2
85	SB	O CSW 1
86	P	O CSW 3
87	BG	O CSW 4
95	V	I SHORTING PIN

Connector No.	M20
Connector Name	BCM (BODY CONTROL MODULE)
Connector Color	BROWN



Terminal No.	Color of Wire	Signal Name
161	W	I PWR ECU
170	B	I GND1
171	B	I GND2

Connector No.	M28
Connector Name	COMBINATION SWITCH (LIGHTING AND TURN SIGNAL SWITCH)
Connector Color	WHITE

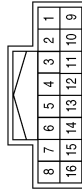

Terminal No.	Color of Wire	Signal Name
1	LG	-
2	SB	-
3	GR	-
4	BG	-
5	G	-

Terminal No.	Color of Wire	Signal Name
6	W	-
7	Y	-
8	V	-
10	BR	-
15	P	-

FRONT FOG LAMP SYSTEM

< WIRING DIAGRAM >

[HALOGEN HEADLAMP]

Connector No.	M43
Connector Name	JOINT CONNECTOR-M02
Connector Color	BLUE

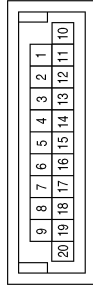

Terminal No.	Color of Wire	Signal Name
1	L	-
2	L	-
5	L	-
11	P	-
12	P	-
15	P	-

Terminal No.	Color of Wire	Signal Name
60J	P	-
61J	L	-

Connector No.	M31
Connector Name	WIRE TO WIRE
Connector Color	WHITE

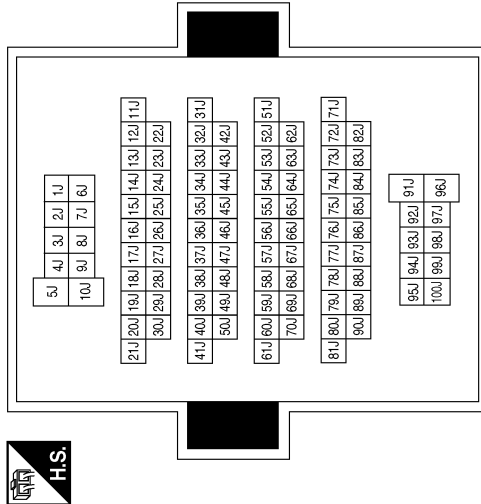

Connector No.	M69
Connector Name	WIRE TO WIRE
Connector Color	WHITE



Terminal No.	Color of Wire	Signal Name
24	P	-
25	L	-

Connector No.	M68
Connector Name	FUSE BLOCK (J/B)
Connector Color	BROWN



Terminal No.	Color of Wire	Signal Name
3R	V	-
14R	W	-

Connector No.	M44
Connector Name	FUSE BLOCK (J/B)
Connector Color	WHITE



Terminal No.	Color of Wire	Signal Name
8P	LA/BR	-
13P	LA/G	-

AALIA2967GB

A
B
C
D
E
F
G
H
I
J
K
EXL
M
N
O
P

FRONT FOG LAMP SYSTEM

< WIRING DIAGRAM >

[HALOGEN HEADLAMP]

Connector No.	E40
Connector Name	WIRE TO WIRE
Connector Color	WHITE



Terminal No.	Color of Wire	Signal Name
2	GR	-

Connector No.	M77
Connector Name	COMBINATION METER
Connector Color	WHITE

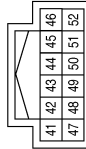

Terminal No.	Color of Wire	Signal Name
41	L	CAN-H
42	P	CAN-L
45	LA/G	BAT
46	LA/BR	IGN
52	B	G1

Connector No.	M76
Connector Name	COMBINATION METER
Connector Color	WHITE

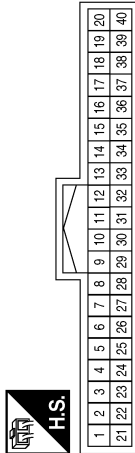

Terminal No.	Color of Wire	Signal Name
1	B	GND

Connector No.	E120
Connector Name	IPDM E/R (INTELLIGENT POWER DISTRIBUTION MODULE ENGINE ROOM)
Connector Color	GRAY

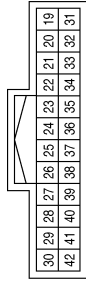

Connector No.	E119
Connector Name	IPDM E/R (INTELLIGENT POWER DISTRIBUTION MODULE ENGINE ROOM)
Connector Color	GRAY

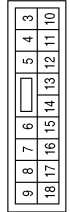

Connector No.	E44
Connector Name	JOINT CONNECTOR-E01
Connector Color	WHITE

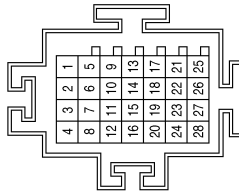

Terminal No.	Color of Wire	Signal Name
22	P	CAN-L
24	L	CAN-H
31	B	2ND SIGNAL GROUND

Terminal No.	Color of Wire	Signal Name
12	B	SIGNAL GROUND

Terminal No.	Color of Wire	Signal Name
5	L	-
6	P	-
9	L	-
10	P	-

AALIA2968GB

FRONT FOG LAMP SYSTEM

< WIRING DIAGRAM >

[HALOGEN HEADLAMP]

Terminal No.	Color of Wire	Signal Name
60J	P	-
61J	L	-

Connector No.	E152
Connector Name	WIRE TO WIRE
Connector Color	WHITE

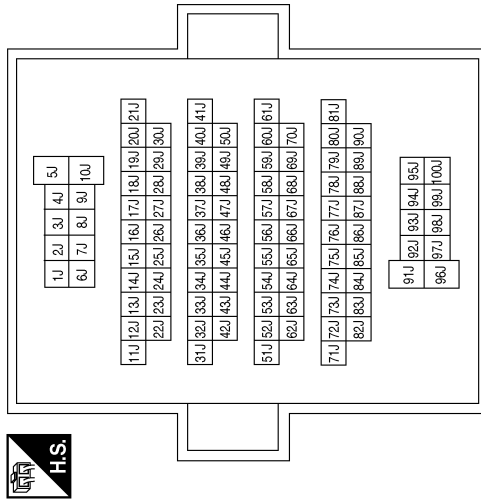

Connector No.	E121
Connector Name	IPDM E/R (INTELLIGENT POWER DISTRIBUTION MODULE ENGINE ROOM)
Connector Color	RED



Terminal No.	Color of Wire	Signal Name
47	B	POWER GROUND

Connector No.	E218
Connector Name	IPDM E/R (INTELLIGENT POWER DISTRIBUTION MODULE ENGINE ROOM)
Connector Color	WHITE



Terminal No.	Color of Wire	Signal Name
57	W	O LIGHT FR FOG LAMPS RH

Connector No.	E217
Connector Name	IPDM E/R (INTELLIGENT POWER DISTRIBUTION MODULE ENGINE ROOM)
Connector Color	BROWN

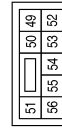

Terminal No.	Color of Wire	Signal Name
51	V	O LIGHT FR FOG LAMPS LH

Connector No.	E201
Connector Name	WIRE TO WIRE
Connector Color	WHITE



Terminal No.	Color of Wire	Signal Name
2	B	-

AALIA2969GB

A
B
C
D
E
F
G
H
I
J
K
L
M
N
O
P

EXL

FRONT FOG LAMP SYSTEM

< WIRING DIAGRAM >

[HALOGEN HEADLAMP]

Connector No.	E221
Connector Name	FRONT FOG LAMP RH
Connector Color	BLACK



Terminal No.	Color of Wire	Signal Name
1	W	-
2	GR	-

Connector No.	E222
Connector Name	FRONT FOG LAMP LH
Connector Color	BLACK



Terminal No.	Color of Wire	Signal Name
1	V	-
2	GR	-

Connector No.	B16
Connector Name	BCM (BODY CONTROL MODULE)
Connector Color	GREEN

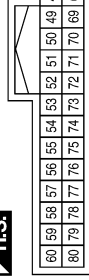

Terminal No.	Color of Wire	Signal Name
60	L	CAN-H
80	P	CAN-L

Connector No.	B41
Connector Name	WIRE TO WIRE
Connector Color	WHITE

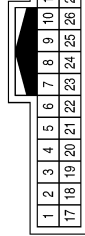

Terminal No.	Color of Wire	Signal Name
24	P	-
25	L	-

Connector No.	B63
Connector Name	JOINT CONNECTOR-B01
Connector Color	GRAY

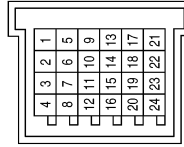

Terminal No.	Color of Wire	Signal Name
3	P	-
4	L	-
7	P	-
8	L	-

TURN SIGNAL AND HAZARD WARNING LAMP SYSTEM

< WIRING DIAGRAM >

[HALOGEN HEADLAMP]

TURN SIGNAL AND HAZARD WARNING LAMP SYSTEM

Wiring Diagram

INFOID:000000011280728

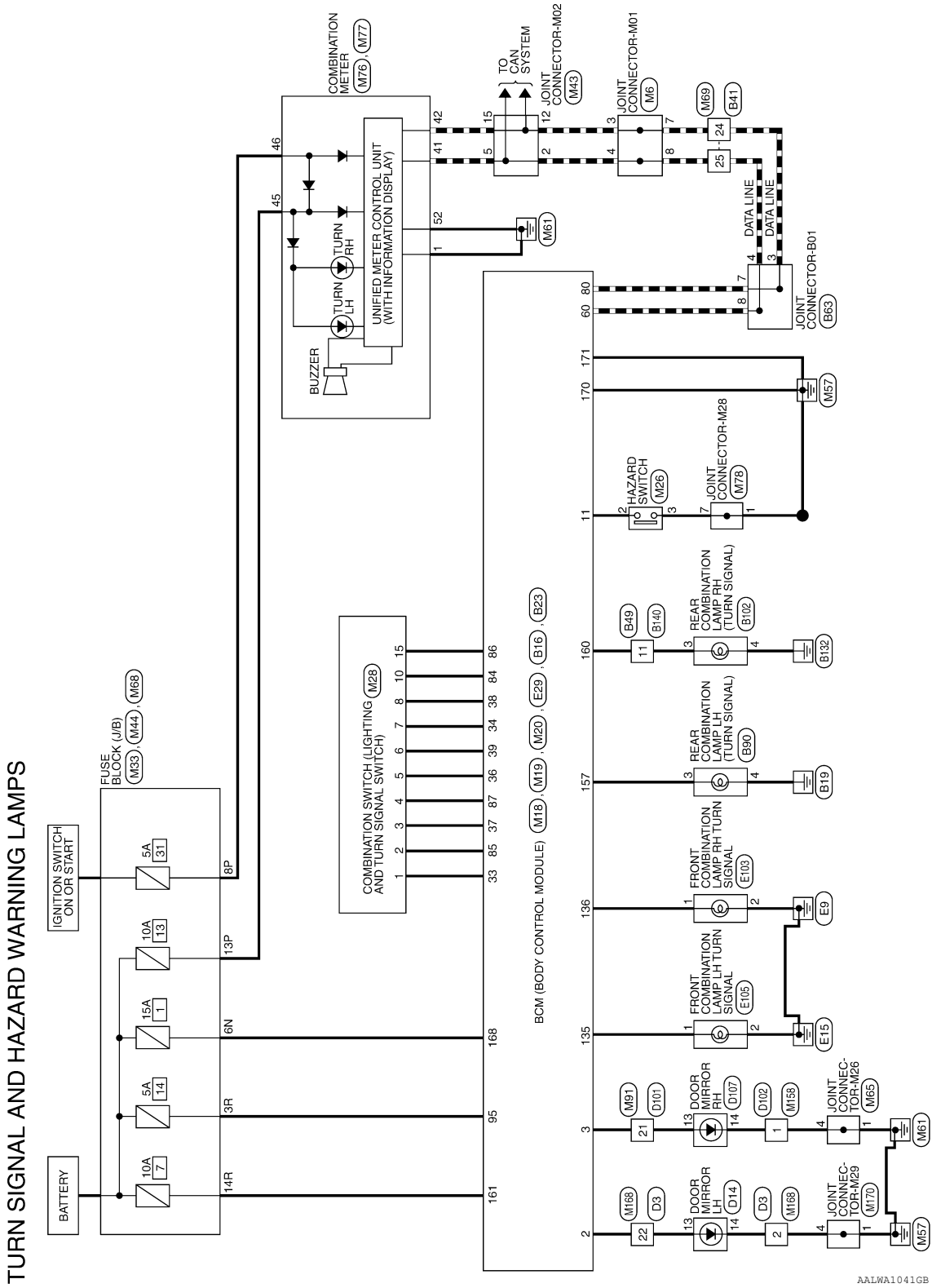

AALWA1041GB

A
B
C
D
E
F
G
H
I
J
K
EXL
M
N
O
P

TURN SIGNAL AND HAZARD WARNING LAMP SYSTEM

[HALOGEN HEADLAMP]

< WIRING DIAGRAM >

TURN SIGNAL AND HAZARD WARNING LAMPS CONNECTORS

Connector No.	M6
Connector Name	JOINT CONNECTOR-M01
Connector Color	GRAY

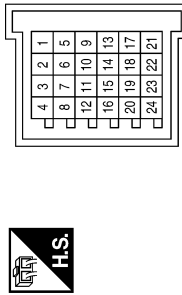

Terminal No.	Color of Wire	Signal Name
3	P	-
4	L	-
7	P	-
8	L	-

Connector No.	M18
Connector Name	BCM (BODY CONTROL MODULE)
Connector Color	GRAY

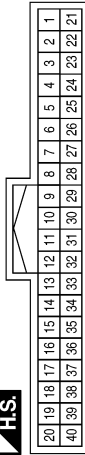

Terminal No.	Color of Wire	Signal Name
2	LA/G	O DI FR LEFT D
3	LAY	O DI FR RIGHT D
11	Y	I HAZARD SW D
33	LG	I CSW 5
34	Y	O CSW 5
36	G	I CSW 3
37	GR	I CSW 4
38	V	I CSW 1
39	W	I CSW 2

Connector No.	M19
Connector Name	BCM (BODY CONTROL MODULE)
Connector Color	BLACK

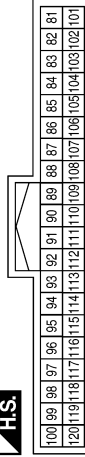

Terminal No.	Color of Wire	Signal Name
84	BR	O CSW 2
85	SB	O CSW 1
86	P	O CSW 3
87	BG	O CSW 4
95	V	I SHORTING PIN

Connector No.	M20
Connector Name	BCM (BODY CONTROL MODULE)
Connector Color	BROWN



Terminal No.	Color of Wire	Signal Name
161	W	I PWR ECU
168	BG	I PWR FLASHERS
170	B	I GND1
171	B	I GND2

Connector No.	M26
Connector Name	HAZARD SWITCH
Connector Color	WHITE



Terminal No.	Color of Wire	Signal Name
2	Y	-
3	GR	-

AALIA2949GB

TURN SIGNAL AND HAZARD WARNING LAMP SYSTEM

< WIRING DIAGRAM >

[HALOGEN HEADLAMP]

Connector No.	M43
Connector Name	JOINT CONNECTOR-M02
Connector Color	BLUE

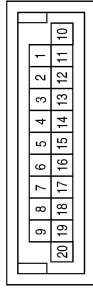

Terminal No.	Color of Wire	Signal Name
2	L	-
5	L	-
12	P	-
15	P	-

Connector No.	M33
Connector Name	FUSE BLOCK (J/B)
Connector Color	WHITE

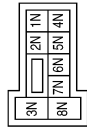

Terminal No.	Color of Wire	Signal Name
6N	BG	-

Connector No.	M28
Connector Name	COMBINATION SWITCH (LIGHTING AND TURN SIGNAL SWITCH)
Connector Color	WHITE

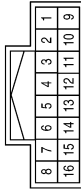

Terminal No.	Color of Wire	Signal Name
1	LG	-
2	SB	-
3	GR	-
4	BG	-
5	G	-
6	W	-
7	Y	-
8	V	-
10	BR	-
15	P	-

Connector No.	M68
Connector Name	FUSE BLOCK (J/B)
Connector Color	BROWN



Terminal No.	Color of Wire	Signal Name
3R	V	-
14R	W	-

Connector No.	M65
Connector Name	JOINT CONNECTOR-M26
Connector Color	WHITE

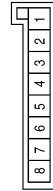

Terminal No.	Color of Wire	Signal Name
1	B	-
4	B	-

Connector No.	M44
Connector Name	FUSE BLOCK (J/B)
Connector Color	WHITE



Terminal No.	Color of Wire	Signal Name
8P	LA/BR	-
13P	LA/G	-

AALIA2950GB

A
B
C
D
E
F
G
H
I
J
K
L
M
N
O
P

EXL

TURN SIGNAL AND HAZARD WARNING LAMP SYSTEM

< WIRING DIAGRAM >

[HALOGEN HEADLAMP]

Connector No.	M77
Connector Name	COMBINATION METER
Connector Color	WHITE

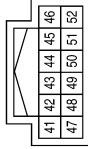

Terminal No.	Color of Wire	Signal Name
41	L	CAN-H
42	P	CAN-L
45	LA/G	BAT
46	LA/BR	IGN
52	B	G1

Connector No.	M76
Connector Name	COMBINATION METER
Connector Color	WHITE

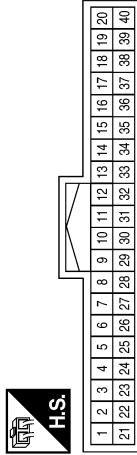

Terminal No.	Color of Wire	Signal Name
1	B	GND

Connector No.	M69
Connector Name	WIRE TO WIRE
Connector Color	WHITE

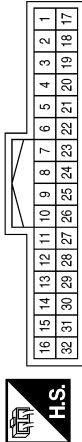

Terminal No.	Color of Wire	Signal Name
24	P	-
25	L	-

Connector No.	M158
Connector Name	WIRE TO WIRE
Connector Color	WHITE



Terminal No.	Color of Wire	Signal Name
1	B	-

Connector No.	M91
Connector Name	WIRE TO WIRE
Connector Color	WHITE

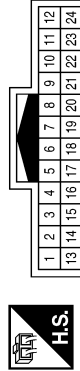

Terminal No.	Color of Wire	Signal Name
21	LAY	-

Connector No.	M78
Connector Name	JOINT CONNECTOR-M28
Connector Color	WHITE

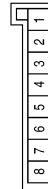

Terminal No.	Color of Wire	Signal Name
1	GR	-
7	GR	-

AALIA2980GB

TURN SIGNAL AND HAZARD WARNING LAMP SYSTEM

< WIRING DIAGRAM >

[HALOGEN HEADLAMP]

Connector No.	E29
Connector Name	BCM (BODY CONTROL MODULE)
Connector Color	BLACK

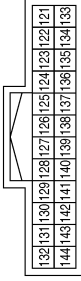

Terminal No.	Color of Wire	Signal Name
135	BR	DI FR LEFT E
136	GR	O DI FR RIGHT E

Connector No.	M170
Connector Name	JOINT CONNECTOR-M29
Connector Color	WHITE



Terminal No.	Color of Wire	Signal Name
1	B	-
4	B	-

Connector No.	M168
Connector Name	WIRE TO WIRE
Connector Color	WHITE

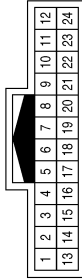

Terminal No.	Color of Wire	Signal Name
2	B	-
22	LA/G	-

Connector No.	B16
Connector Name	BCM (BODY CONTROL MODULE)
Connector Color	GREEN

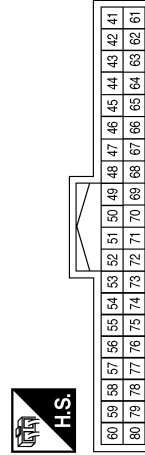

Terminal No.	Color of Wire	Signal Name
60	L	CAN-H
80	P	CAN-L

Connector No.	E105
Connector Name	FRONT COMBINATION LAMP LH
Connector Color	GRAY



Terminal No.	Color of Wire	Signal Name
1	BR	-
2	B	-

Connector No.	E103
Connector Name	FRONT COMBINATION LAMP RH
Connector Color	GRAY



Terminal No.	Color of Wire	Signal Name
1	GR	-
2	BR	-

AALIA2165GB

A
B
C
D
E
F
G
H
I
J
K
EXL
M
N
O
P

TURN SIGNAL AND HAZARD WARNING LAMP SYSTEM

< WIRING DIAGRAM >

[HALOGEN HEADLAMP]

Connector No.	B49
Connector Name	WIRE TO WIRE
Connector Color	WHITE

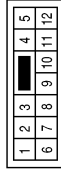

Terminal No.	Color of Wire	Signal Name
11	P	-

Connector No.	B41
Connector Name	WIRE TO WIRE
Connector Color	WHITE

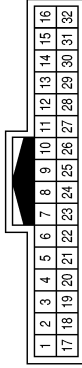

Terminal No.	Color of Wire	Signal Name
24	P	-
25	L	-

Connector No.	B23
Connector Name	BCM (BODY CONTROL MODULE)
Connector Color	GRAY



Terminal No.	Color of Wire	Signal Name
157	GR	O D I RR LEFT B
160	P	O D I RR RIGHT B

Connector No.	B102
Connector Name	REAR COMBINATION LAMP RH
Connector Color	WHITE



Terminal No.	Color of Wire	Signal Name
3	LA/V	-
4	B	-

Connector No.	B90
Connector Name	REAR COMBINATION LAMP LH
Connector Color	WHITE



Terminal No.	Color of Wire	Signal Name
3	GR	-
4	B	-

Connector No.	B63
Connector Name	JOINT CONNECTOR-B01
Connector Color	GRAY

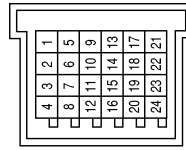

Terminal No.	Color of Wire	Signal Name
3	P	-
4	L	-
7	P	-
8	L	-

AALIA2166GB

TURN SIGNAL AND HAZARD WARNING LAMP SYSTEM

< WIRING DIAGRAM >

[HALOGEN HEADLAMP]

Connector No.	D14
Connector Name	DOOR MIRROR LH
Connector Color	WHITE

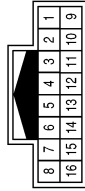

Terminal No.	Color of Wire	Signal Name
13	LA/G	-
14	LA/B	-

Connector No.	D3
Connector Name	WIRE TO WIRE
Connector Color	WHITE

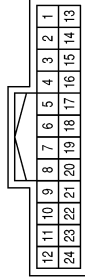

Terminal No.	Color of Wire	Signal Name
2	LA/B	-
22	LA/G	-

Connector No.	B140
Connector Name	WIRE TO WIRE
Connector Color	WHITE

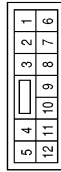

Terminal No.	Color of Wire	Signal Name
11	LAV	-

Connector No.	D107
Connector Name	DOOR MIRROR RH
Connector Color	WHITE

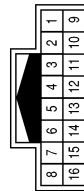

Terminal No.	Color of Wire	Signal Name
13	LA/G	-
14	LA/B	-

Connector No.	D102
Connector Name	WIRE TO WIRE
Connector Color	WHITE

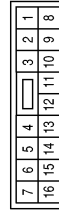

Terminal No.	Color of Wire	Signal Name
1	LA/B	-

Connector No.	D101
Connector Name	WIRE TO WIRE
Connector Color	WHITE

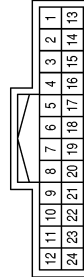

Terminal No.	Color of Wire	Signal Name
21	LA/G	-

AALIA2239GB

A
B
C
D
E
F
G
H
I
J
K
EXL
M
N
O
P

PARKING, LICENSE PLATE AND TAIL LAMPS SYSTEM

< WIRING DIAGRAM >

[HALOGEN HEADLAMP]

PARKING, LICENSE PLATE AND TAIL LAMPS SYSTEM

Wiring Diagram

INFOID:000000011280729

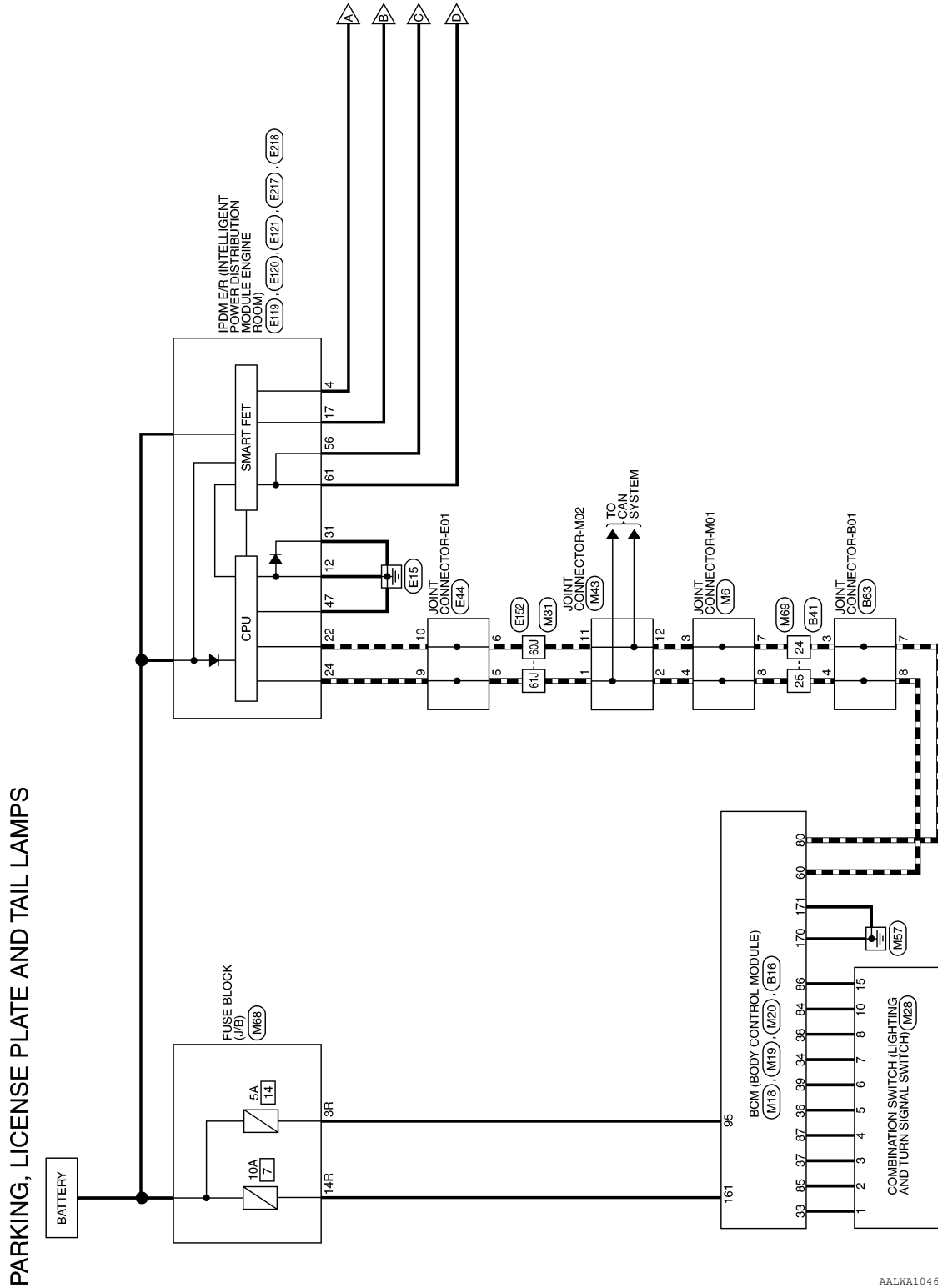

AALWA1046GB

PARKING, LICENSE PLATE AND TAIL LAMPS SYSTEM

< WIRING DIAGRAM >

[HALOGEN HEADLAMP]

<HK> : WITH HALOGEN HEADLAMPS
 <LV> : WITH LED HEADLAMPS
 *1 <HK> : 12 *2 <HK> : 9
 *1 <LV> : 9 *2 <LV> : 10

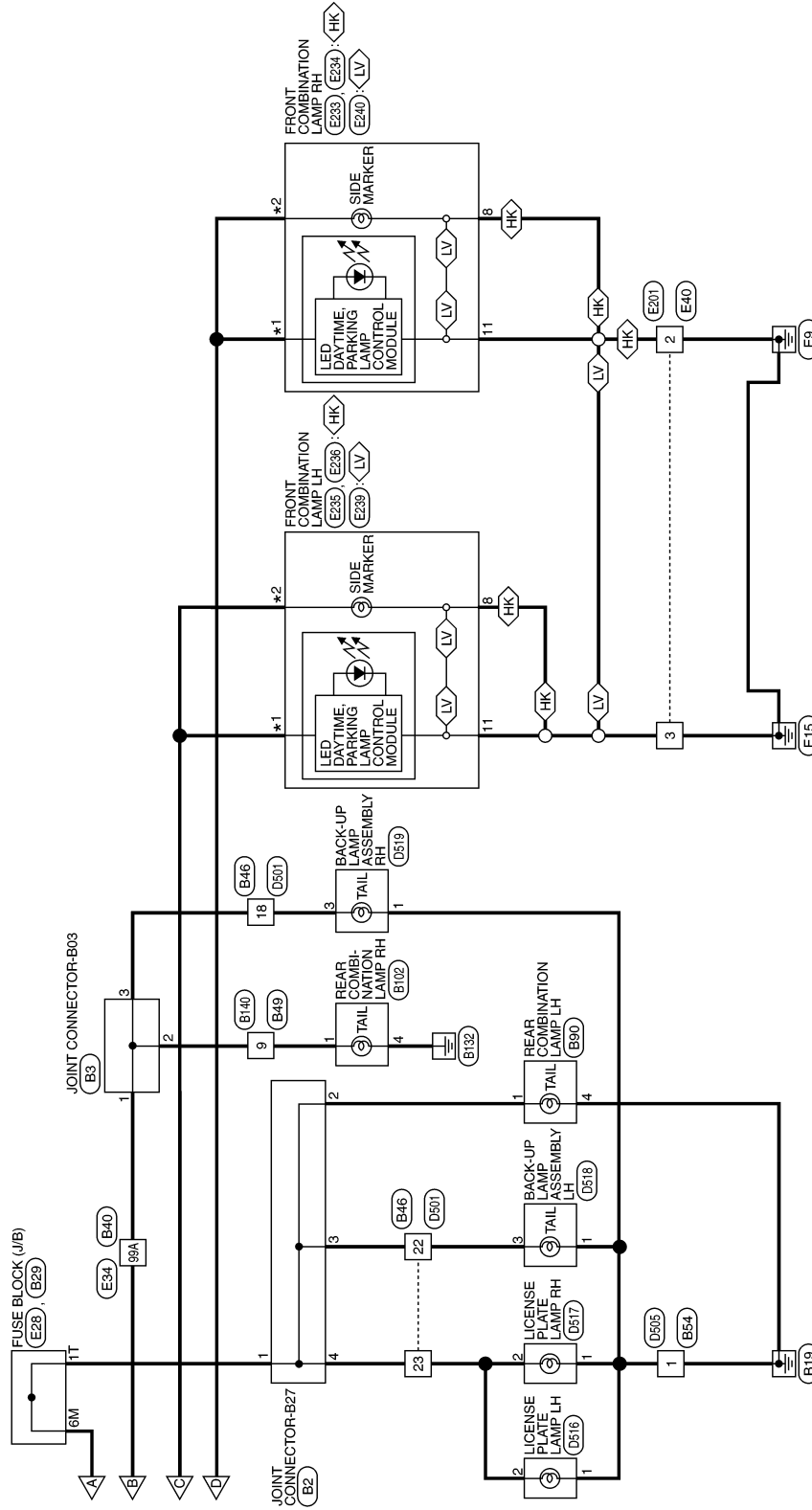

AALWA1047GB

A
B
C
D
E
F
G
H
I
J
K
EXL
M
N
O
P

PARKING, LICENSE PLATE AND TAIL LAMPS SYSTEM

< WIRING DIAGRAM >

[HALOGEN HEADLAMP]

PARKING, LICENSE AND TAIL LAMPS CONNECTORS

Connector No.	M6
Connector Name	JOINT CONNECTOR-M01
Connector Color	GRAY

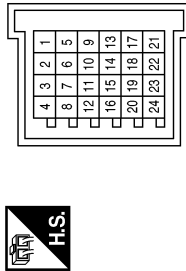

Terminal No.	Color of Wire	Signal Name
3	P	-
4	L	-
7	P	-
8	L	-

Connector No.	M18
Connector Name	BCM (BODY CONTROL MODULE)
Connector Color	GRAY

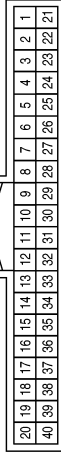

Terminal No.	Color of Wire	Signal Name
33	LG	I CSW 5
34	Y	O CSW 5
36	G	I CSW 3
37	GR	I CSW 4
38	V	I CSW 1
39	W	I CSW 2

Connector No.	M19
Connector Name	BCM (BODY CONTROL MODULE)
Connector Color	BLACK



Terminal No.	Color of Wire	Signal Name
84	BR	O CSW 2
85	SB	O CSW 1
86	P	O CSW 3
87	BG	O CSW 4
95	V	I SHORTING PIN

Connector No.	M20
Connector Name	BCM (BODY CONTROL MODULE)
Connector Color	BROWN



Terminal No.	Color of Wire	Signal Name
161	W	I PWR ECU
170	B	I GND1
171	B	I GND2

Connector No.	M28
Connector Name	COMBINATION SWITCH (LIGHTING AND TURN SIGNAL SWITCH)
Connector Color	WHITE

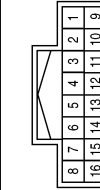

Terminal No.	Color of Wire	Signal Name
1	LG	-
2	SB	-
3	GR	-
4	BG	-

Terminal No.	Color of Wire	Signal Name
5	G	-
6	W	-
7	Y	-
8	V	-
10	BR	-
15	P	-

PARKING, LICENSE PLATE AND TAIL LAMPS SYSTEM

< WIRING DIAGRAM >

[HALOGEN HEADLAMP]

Connector No.	M43
Connector Name	JOINT CONNECTOR-M02
Connector Color	BLUE

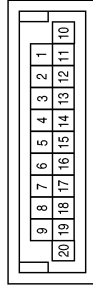

Terminal No.	Color of Wire	Signal Name
1	L	-
2	L	-
11	P	-
12	P	-

Terminal No.	Color of Wire	Signal Name
60J	P	-
61J	L	-

Connector No.	M31
Connector Name	WIRE TO WIRE
Connector Color	WHITE

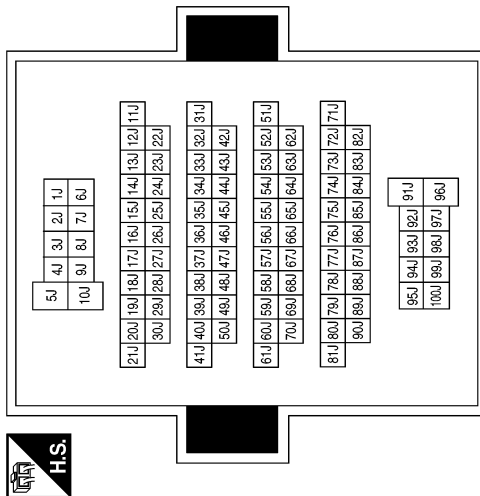

Connector No.	E28
Connector Name	FUSE BLOCK (J/B)
Connector Color	WHITE



Terminal No.	Color of Wire	Signal Name
6M	Y	-

Connector No.	M69
Connector Name	WIRE TO WIRE
Connector Color	WHITE

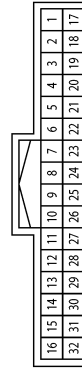

Terminal No.	Color of Wire	Signal Name
24	P	-
25	L	-

Connector No.	M68
Connector Name	FUSE BLOCK (J/B)
Connector Color	BROWN



Terminal No.	Color of Wire	Signal Name
3R	V	-
14R	W	-

AALIA2958GB

A
B
C
D
E
F
G
H
I
J
K
L
M
N
O
P

EXL

PARKING, LICENSE PLATE AND TAIL LAMPS SYSTEM

< WIRING DIAGRAM >

[HALOGEN HEADLAMP]

Connector No.	E40
Connector Name	WIRE TO WIRE
Connector Color	WHITE



Terminal No.	Color of Wire	Signal Name
2	GR	-
3	B	-

Terminal No.	99A	Color of Wire	W	Signal Name	-
--------------	-----	---------------	---	-------------	---

Connector No.	E34
Connector Name	WIRE TO WIRE
Connector Color	GRAY

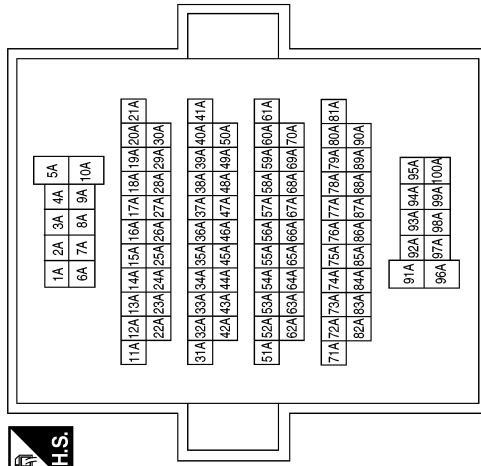

Connector No.	E119
Connector Name	IPDM E/R (INTELLIGENT POWER DISTRIBUTION MODULE ENGINE ROOM)
Connector Color	GRAY

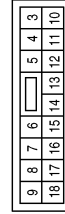

Terminal No.	Color of Wire	Signal Name
4	Y	O LIGHT POSITION REAR LH
12	B	SIGNAL GROUND
17	W	O LIGHT POSITION REAR RH

Terminal No.	5	Color of Wire	L	Signal Name	-
	6	Color of Wire	P	Signal Name	-
	9	Color of Wire	L	Signal Name	-
	10	Color of Wire	P	Signal Name	-

Connector No.	E44
Connector Name	JOINT CONNECTOR-E01
Connector Color	WHITE

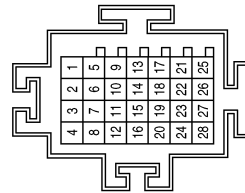

AALIA2959GB

PARKING, LICENSE PLATE AND TAIL LAMPS SYSTEM

< WIRING DIAGRAM >

[HALOGEN HEADLAMP]

Connector No.	E121
Connector Name	IPDM E/R (INTELLIGENT POWER DISTRIBUTION MODULE ENGINE ROOM)
Connector Color	RED



Terminal No.	Color of Wire	Signal Name
47	B	POWER GROUND

Connector No.	E120
Connector Name	IPDM E/R (INTELLIGENT POWER DISTRIBUTION MODULE ENGINE ROOM)
Connector Color	GRAY

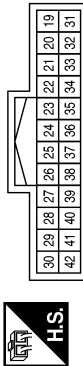

Terminal No.	Color of Wire	Signal Name
22	P	CAN-L
24	L	CAN-H
31	B	2ND SIGNAL GROUND

Connector No.	E201
Connector Name	WIRE TO WIRE
Connector Color	WHITE



Terminal No.	Color of Wire	Signal Name
2	B	-
3	B	-

Terminal No.	Color of Wire	Signal Name
60J	P	-
61J	L	-

Connector No.	E152
Connector Name	WIRE TO WIRE
Connector Color	WHITE

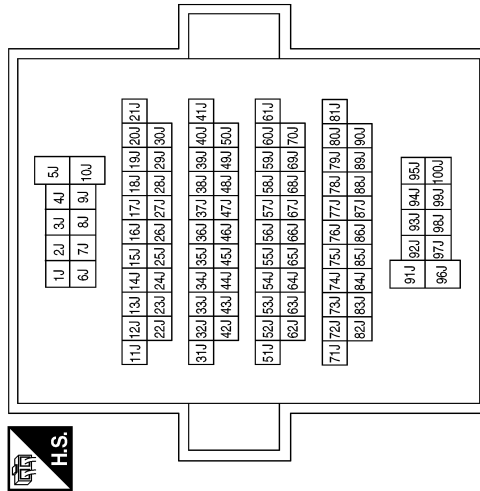

AALIA2960GB

A
B
C
D
E
F
G
H
I
J
K
EXL
M
N
O
P

PARKING, LICENSE PLATE AND TAIL LAMPS SYSTEM

< WIRING DIAGRAM >

[HALOGEN HEADLAMP]

Connector No.	E233
Connector Name	FRONT COMBINATION LAMP RH (WITH HALOGEN HEADLAMPS)
Connector Color	BLACK



Terminal No.	Color of Wire	Signal Name
8	B	-
9	W	-

Connector No.	E218
Connector Name	IPDM E/R (INTELLIGENT POWER DISTRIBUTION MODULE ENGINE ROOM)
Connector Color	WHITE

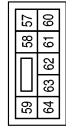

Terminal No.	Color of Wire	Signal Name
61	GR	O LIGHT CLEARANCE FR RH

Connector No.	E217
Connector Name	IPDM E/R (INTELLIGENT POWER DISTRIBUTION MODULE ENGINE ROOM)
Connector Color	BROWN

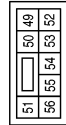

Terminal No.	Color of Wire	Signal Name
56	BG	O LIGHT CLEARANCE FR LH

Connector No.	E236
Connector Name	FRONT COMBINATION LAMP LH (WITH HALOGEN HEADLAMPS)
Connector Color	GRAY



Terminal No.	Color of Wire	Signal Name
11	GR	-
12	BG	-

Connector No.	E235
Connector Name	FRONT COMBINATION LAMP LH (WITH HALOGEN HEADLAMPS)
Connector Color	BLACK



Terminal No.	Color of Wire	Signal Name
8	B	-
9	P	-

Connector No.	E234
Connector Name	FRONT COMBINATION LAMP RH (WITH HALOGEN HEADLAMPS)
Connector Color	GRAY



Terminal No.	Color of Wire	Signal Name
11	GR	-
12	GR	-

AALIA2961GB

PARKING, LICENSE PLATE AND TAIL LAMPS SYSTEM

< WIRING DIAGRAM >

[HALOGEN HEADLAMP]

Connector No.	B2
Connector Name	JOINT CONNECTOR-B27
Connector Color	WHITE



Terminal No.	Color of Wire	Signal Name
1	LA/R	-
2	LA/R	-
3	LA/R	-
4	LA/R	-

Connector No.	E240
Connector Name	FRONT COMBINATION LAMP RH (WITH LED HEADLAMPS)
Connector Color	BLACK

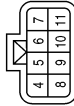

Terminal No.	Color of Wire	Signal Name
9	GR	-
10	W	-
11	B	-

Connector No.	E239
Connector Name	FRONT COMBINATION LAMP LH (WITH LED HEADLAMPS)
Connector Color	BLACK

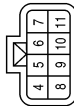

Terminal No.	Color of Wire	Signal Name
9	BG	-
10	P	-
11	B	-

Connector No.	B29
Connector Name	FUSE BLOCK (J/B)
Connector Color	WHITE

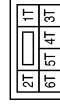

Terminal No.	Color of Wire	Signal Name
1T	LA/R	-

Connector No.	B16
Connector Name	BCM (BODY CONTROL MODULE)
Connector Color	GREEN

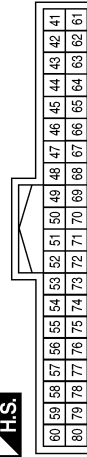

Terminal No.	Color of Wire	Signal Name
60	L	CAN-H
80	P	CAN-L

Connector No.	B3
Connector Name	JOINT CONNECTOR-B03
Connector Color	WHITE



Terminal No.	Color of Wire	Signal Name
1	LA/BR	-
2	LA/BR	-
3	LA/BR	-

AALIA2962GB

A
B
C
D
E
F
G
H
I
J
K
L
M
N
O
P

EXL

PARKING, LICENSE PLATE AND TAIL LAMP SYSTEM

< WIRING DIAGRAM >

[HALOGEN HEADLAMP]

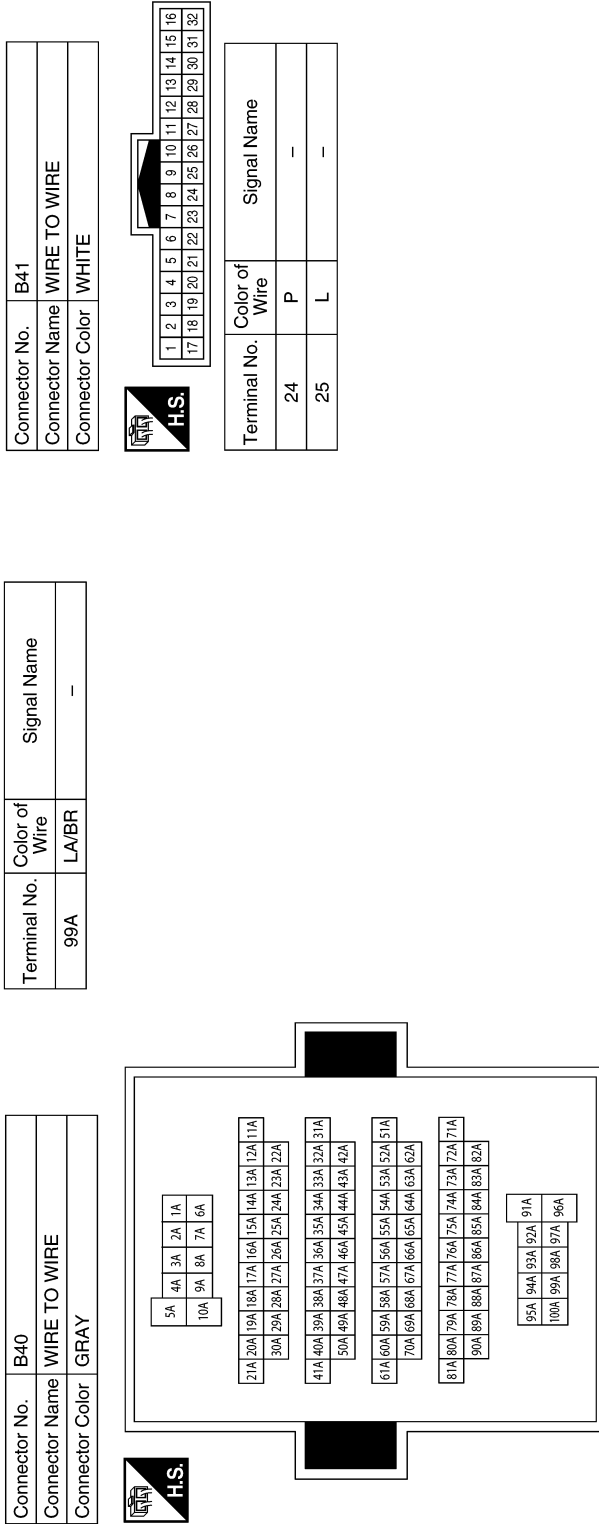

Terminal No.	Color of Wire	Signal Name
99A	LA/BR	-

Connector No.	B41
Connector Name	WIRE TO WIRE
Connector Color	WHITE

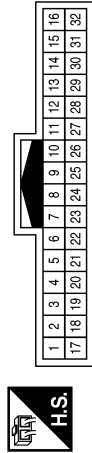

Terminal No.	Color of Wire	Signal Name
24	P	-
25	L	-

Connector No.	B46
Connector Name	WIRE TO WIRE
Connector Color	WHITE

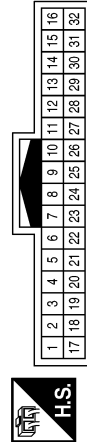

Terminal No.	Color of Wire	Signal Name
18	LA/BR	-
22	LA/R	-
23	LA/R	-

Connector No.	B49
Connector Name	WIRE TO WIRE
Connector Color	WHITE



Terminal No.	Color of Wire	Signal Name
9	LA/BR	-

Connector No.	B54
Connector Name	WIRE TO WIRE
Connector Color	WHITE



Terminal No.	Color of Wire	Signal Name
1	B	-

PARKING, LICENSE PLATE AND TAIL LAMPS SYSTEM

< WIRING DIAGRAM >

[HALOGEN HEADLAMP]

Connector No.	B102
Connector Name	REAR COMBINATION LAMP RH
Connector Color	WHITE



Terminal No.	Color of Wire	Signal Name
1	LA/BR	-
4	B	-

Connector No.	B90
Connector Name	REAR COMBINATION LAMP LH
Connector Color	WHITE



Terminal No.	Color of Wire	Signal Name
1	LA/R	-
4	B	-

Connector No.	B63
Connector Name	JOINT CONNECTOR-B01
Connector Color	GRAY

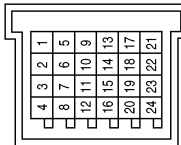

Terminal No.	Color of Wire	Signal Name
3	P	-
4	L	-
7	P	-
8	L	-

Connector No.	D505
Connector Name	WIRE TO WIRE
Connector Color	WHITE



Terminal No.	Color of Wire	Signal Name
1	B	-

Connector No.	D501
Connector Name	WIRE TO WIRE
Connector Color	WHITE

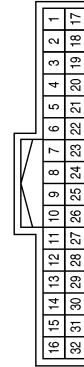

Terminal No.	Color of Wire	Signal Name
18	LA/R	-
22	LA/Y	-
23	P	-

Connector No.	B140
Connector Name	WIRE TO WIRE
Connector Color	WHITE



Terminal No.	Color of Wire	Signal Name
9	LA/BR	-

A
B
C
D
E
F
G
H
I
J
K
EXL
M
N
O
P

PARKING, LICENSE PLATE AND TAIL LAMPS SYSTEM

< WIRING DIAGRAM >

[HALOGEN HEADLAMP]

Connector No.	D518
Connector Name	BACK-UP LAMP ASSEMBLY LH
Connector Color	WHITE

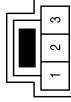

Terminal No.	Color of Wire	Signal Name
1	GR	-
3	LAVY	-

Connector No.	D517
Connector Name	LICENSE PLATE LAMP RH
Connector Color	BROWN



Terminal No.	Color of Wire	Signal Name
1	B	-
2	R	-

Connector No.	D516
Connector Name	LICENSE PLATE LAMP LH
Connector Color	BROWN



Terminal No.	Color of Wire	Signal Name
1	B	-
2	P	-

AALIA2978GB

STOP LAMP

[HALOGEN HEADLAMP]

< WIRING DIAGRAM >

STOP LAMP

Wiring Diagram

INFOID:000000011280730

STOP LAMP

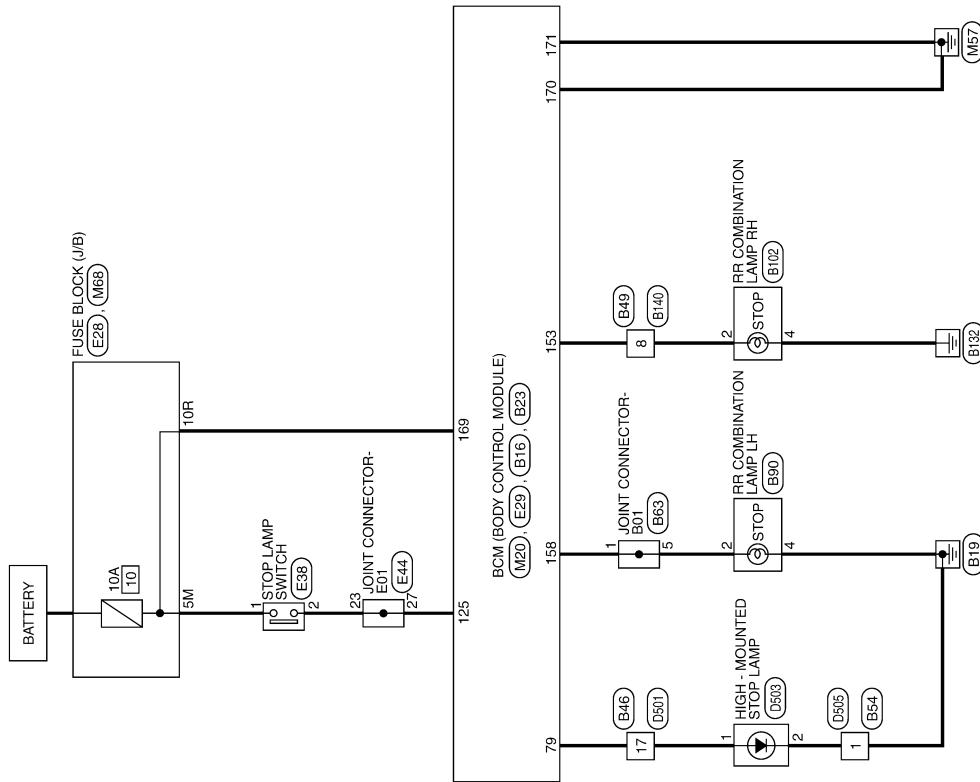

A
B
C
D
E
F
G
H
I
J
K
EXL
M
N
O
P

AALWA1042GB

STOP LAMP

< WIRING DIAGRAM >

[HALOGEN HEADLAMP]

STOP LAMP CONNECTORS

Connector No.	M20
Connector Name	BCM (BODY CONTROL MODULE)
Connector Color	BROWN



Terminal No.	Color of Wire	Signal Name
169	GR	I PWR STOP LAMP
170	B	I GND1
171	B	I GND2

Connector No.	M68
Connector Name	FUSE BLOCK (J/B)
Connector Color	BROWN



Terminal No.	Color of Wire	Signal Name
10R	GR	-

Connector No.	E28
Connector Name	FUSE BLOCK (J/B)
Connector Color	WHITE

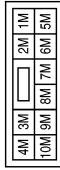

Terminal No.	Color of Wire	Signal Name
5M	V	-

Connector No.	E29
Connector Name	BCM (BODY CONTROL MODULE)
Connector Color	BLACK

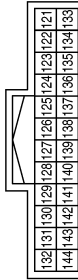

Terminal No.	Color of Wire	Signal Name
125	LG	I BRAKE SW2

Connector No.	E38
Connector Name	STOP LAMP SWITCH
Connector Color	WHITE



Terminal No.	Color of Wire	Signal Name
1	V	-
2	LG	-

Connector No.	E44
Connector Name	JOINT CONNECTOR-E01
Connector Color	WHITE

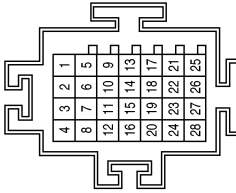

Terminal No.	Color of Wire	Signal Name
23	LG	-
27	LG	-

STOP LAMP

< WIRING DIAGRAM >

[HALOGEN HEADLAMP]

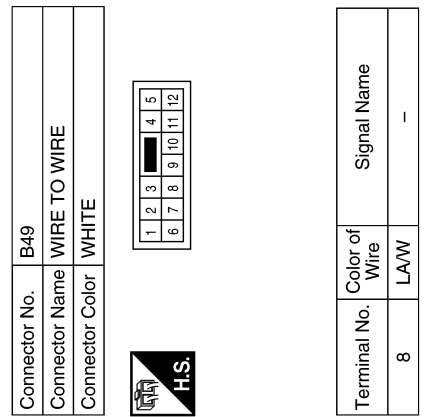
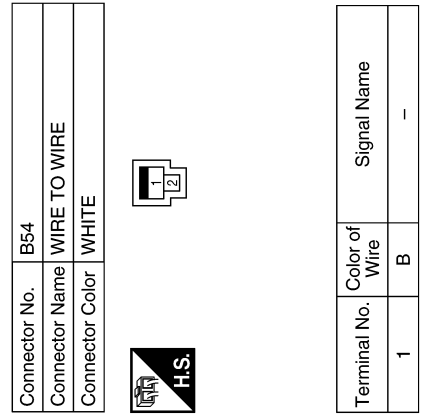
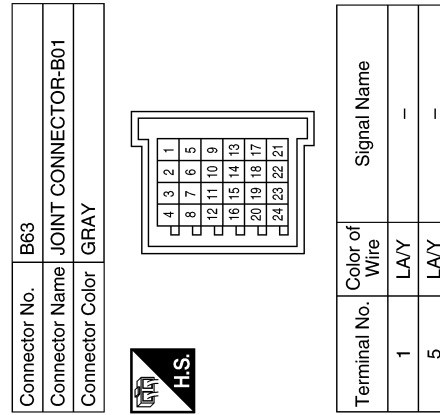
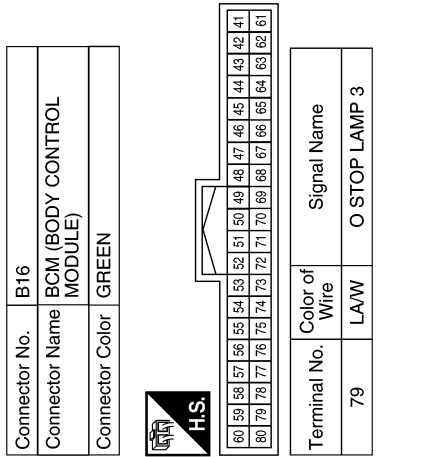
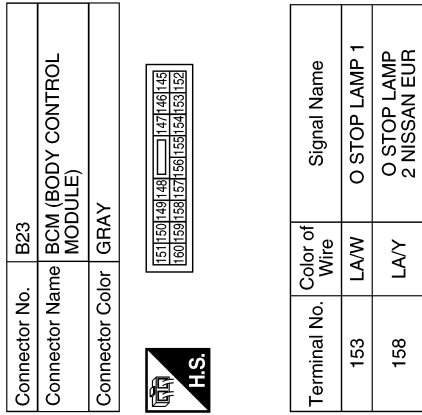
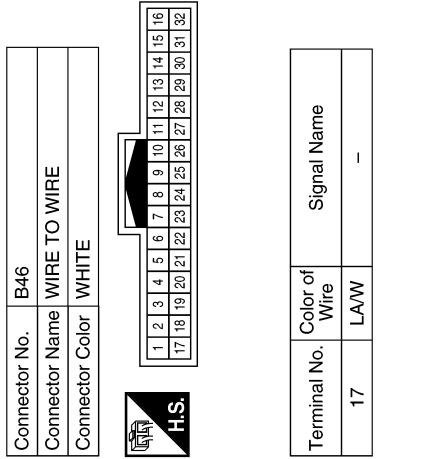

AALIA2159GB

A
B
C
D
E
F
G
H
I
J
K
L
M
N
O
P

EXL

STOP LAMP

< WIRING DIAGRAM >

[HALOGEN HEADLAMP]

Connector No.	B140
Connector Name	WIRE TO WIRE
Connector Color	WHITE

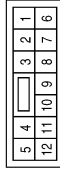

Terminal No.	8	Color of Wire	LAY	Signal Name	-
--------------	---	---------------	-----	-------------	---

Connector No.	B102
Connector Name	REAR COMBINATION LAMP RH
Connector Color	WHITE



Terminal No.	2	Color of Wire	LAY	Signal Name	-
4	B				-

Connector No.	B90
Connector Name	REAR COMBINATION LAMP LH
Connector Color	WHITE



Terminal No.	2	Color of Wire	LAY	Signal Name	-
4	B				-

Connector No.	D505
Connector Name	WIRE TO WIRE
Connector Color	WHITE



Terminal No.	1	Color of Wire	B	Signal Name	-
--------------	---	---------------	---	-------------	---

Connector No.	D503
Connector Name	HIGH-MOUNTED STOP LAMP
Connector Color	WHITE



Terminal No.	1	Color of Wire	Y	Signal Name	-
2	B				-

Connector No.	D501
Connector Name	WIRE TO WIRE
Connector Color	WHITE

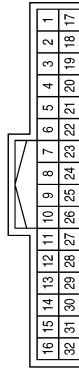

Terminal No.	17	Color of Wire	Y	Signal Name	-
--------------	----	---------------	---	-------------	---

AALIA2160GB

BACK-UP LAMP

[HALOGEN HEADLAMP]

< WIRING DIAGRAM >

BACK-UP LAMP

Wiring Diagram

INFOID:0000000011280731

BACK-UP LAMP

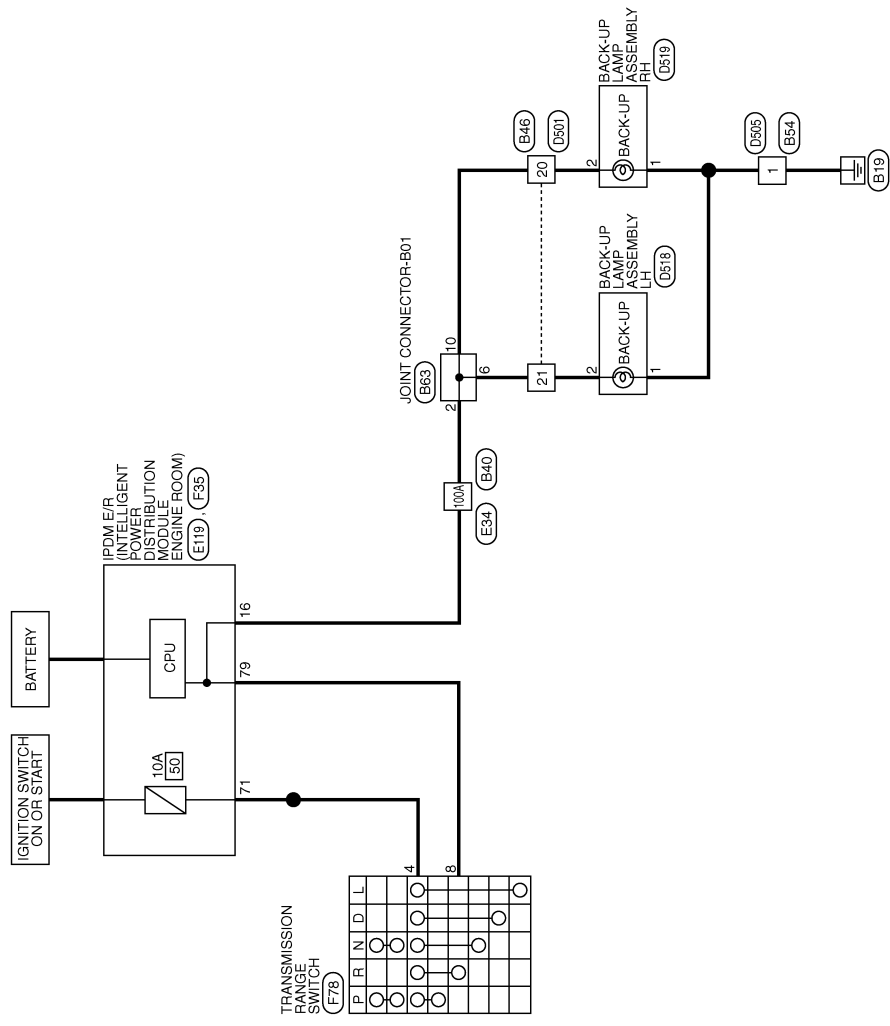

A
B
C
D
E
F
G
H
I
J
K
EXL
M
N
O
P

AALWA1044GB

BACK-UP LAMP

< WIRING DIAGRAM >

[HALOGEN HEADLAMP]

BACK-UP LAMP CONNECTORS

Connector No.	E34
Connector Name	WIRE TO WIRE
Connector Color	GRAY

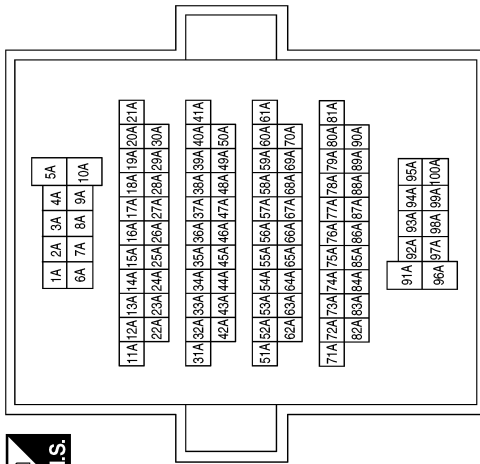

Terminal No.	Color of Wire	Signal Name
100A	G	-

Connector No.	E119
Connector Name	IPDM E/R (INTELLIGENT POWER DISTRIBUTION MODULE ENGINE ROOM)
Connector Color	GRAY

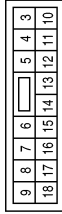

Terminal No.	Color of Wire	Signal Name
16	G	O LIGHT REVERSE LAMP

Connector No.	F35
Connector Name	IPDM E/R (INTELLIGENT POWER DISTRIBUTION MODULE ENGINE ROOM)
Connector Color	WHITE



Connector No.	F78
Connector Name	TRANSMISSION RANGE SWITCH
Connector Color	BLACK

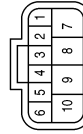

Terminal No.	Color of Wire	Signal Name
71	SB	O IGN REVERSE SW AC VALVE
79	G	LI LIGHT REVERSE SW

Terminal No.	Color of Wire	Signal Name
4	W	-
8	G	-

BACK-UP LAMP

< WIRING DIAGRAM >

[HALOGEN HEADLAMP]

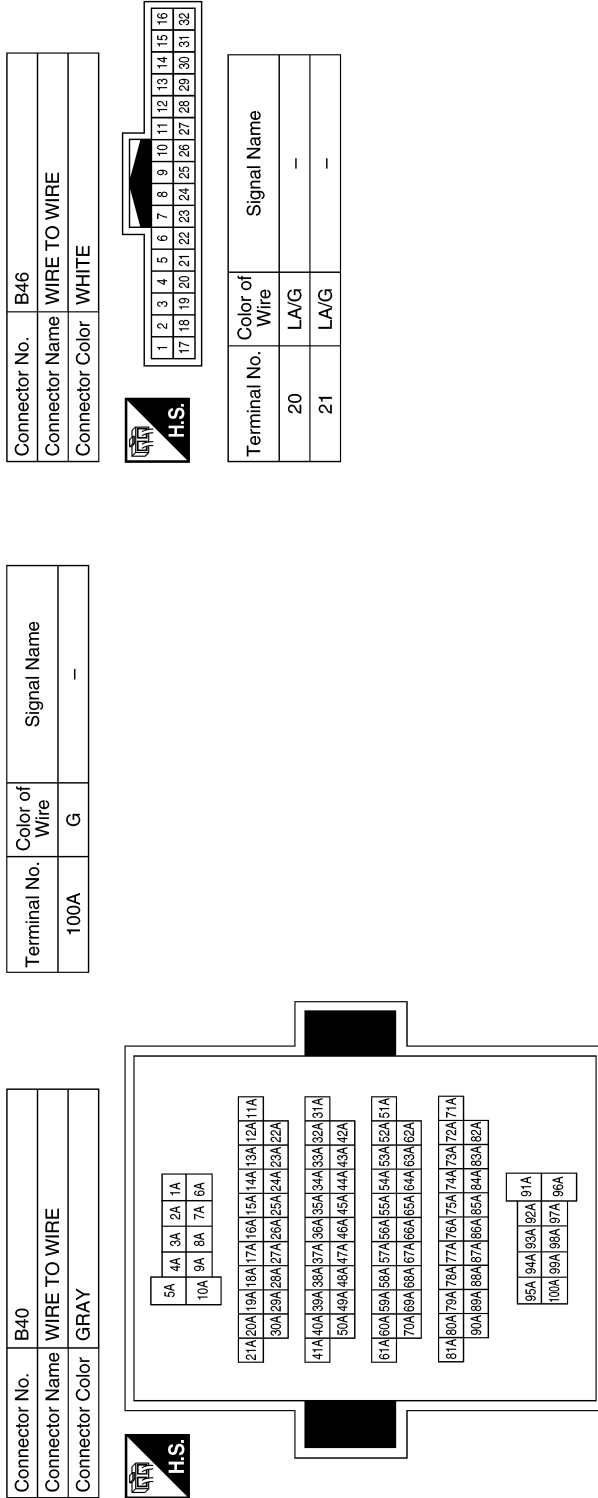

AALIA2119GB

A
B
C
D
E
F
G
H
I
J
K
EXL
M
N
O
P

BACK-UP LAMP

< WIRING DIAGRAM >

[HALOGEN HEADLAMP]

Connector No.	D519
Connector Name	BACK-UP LAMP ASSEMBLY RH
Connector Color	WHITE

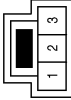

Terminal No.	Color of Wire	Signal Name
1	GR	-
2	LA/L	-

Connector No.	D518
Connector Name	BACK-UP LAMP ASSEMBLY LH
Connector Color	WHITE

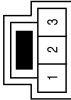

Terminal No.	Color of Wire	Signal Name
1	GR	-
2	LA/G	-

Connector No.	D505
Connector Name	WIRE TO WIRE
Connector Color	WHITE



Terminal No.	Color of Wire	Signal Name
1	B	-

AALIA2120GB

DIAGNOSIS AND REPAIR WORKFLOW

< BASIC INSPECTION >

[HALOGEN HEADLAMP]

BASIC INSPECTION

DIAGNOSIS AND REPAIR WORKFLOW

Work Flow

INFOID:000000011280732

OVERALL SEQUENCE

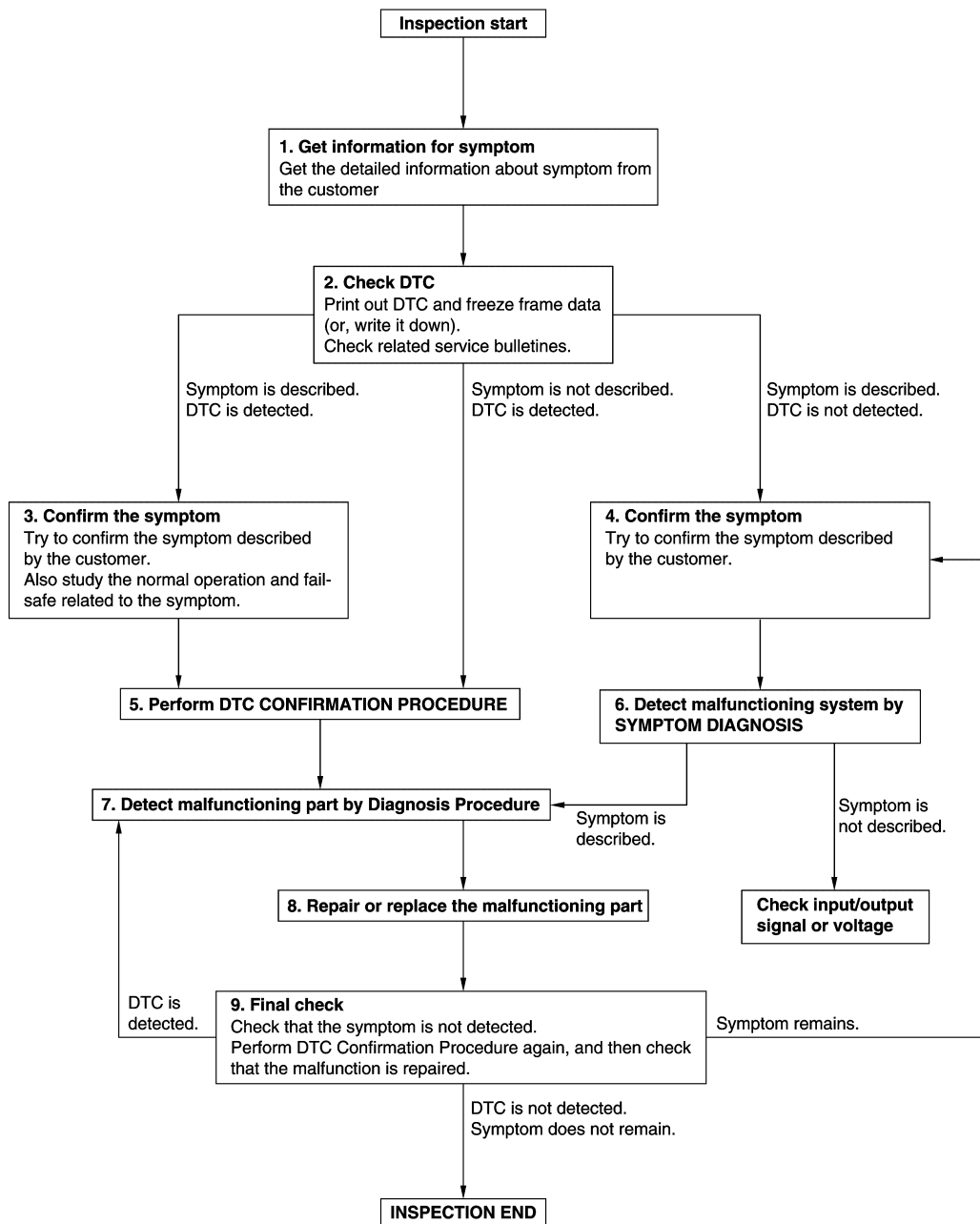

DETAILED FLOW

Revision: August 2014

EXL-81

2015 Rogue NAM

JMKIA8652GB

A
B
C
D
E
F
G
H
I
J
K
EXL
M
N
O
P

DIAGNOSIS AND REPAIR WORKFLOW

< BASIC INSPECTION >

[HALOGEN HEADLAMP]

1. GET INFORMATION FOR SYMPTOM

1. Get detailed information from the customer about the symptom (the condition and the environment when the incident/malfunction occurs).
2. Check operation condition of the function that is malfunctioning.

>> GO TO 2.

2. CHECK DTC

1. Check DTC.
2. Perform the following procedure if DTC is detected:
 - Record DTC and freeze frame data (Print them out using CONSULT.)
 - Erase DTC.
 - Study the relationship between the cause detected by DTC and the symptom described by the customer.
3. Check related service bulletins for information.

Are any symptoms described and any DTC detected?

Symptom is described, DTC is detected>>GO TO 3.

Symptom is described, DTC is not detected>>GO TO 4.

Symptom is not described, DTC is detected>>GO TO 5.

3. CONFIRM THE SYMPTOM

Try to confirm the symptom described by the customer.

Also study the normal operation and fail-safe related to the symptom.

Verify relation between the symptom and the condition when the symptom is detected.

>> GO TO 5.

4. CONFIRM THE SYMPTOM

Try to confirm the symptom described by the customer.

Verify relation between the symptom and the condition when the symptom is detected.

>> GO TO 6.

5. PERFORM DTC CONFIRMATION PROCEDURE

Perform DTC CONFIRMATION PROCEDURE for the detected DTC, and then check that DTC is detected again. At this time, always connect CONSULT to the vehicle, and check self diagnostic results in real time.

If two or more DTCs are detected, refer to [BCS-46, "DTC Inspection Priority Chart"](#) (BCM) (with Intelligent Key System) or [BCS-107, "DTC Inspection Priority Chart"](#) (BCM) (without Intelligent Key System) or [PCS-14, "Reference Value"](#) (IPDM E/R), and determine trouble diagnosis order.

NOTE:

- Freeze frame data is useful if the DTC is not detected.
- Perform Component Function Check if DTC CONFIRMATION PROCEDURE is not included on Service Manual. This simplified check procedure is an effective alternative though DTC cannot be detected during this check.
If the result of Component Function Check is NG, it is the same as the detection of DTC by DTC CONFIRMATION PROCEDURE.

Is DTC detected?

YES >> GO TO 7.

NO >> Check according to [GI-44, "Intermittent Incident"](#).

6. DETECT MALFUNCTIONING SYSTEM BY SYMPTOM DIAGNOSIS

Detect malfunctioning system according to SYMPTOM DIAGNOSIS based on the confirmed symptom in step 4, and determine the trouble diagnosis order based on possible causes and symptom.

Is the symptom described?

YES >> GO TO 7.

NO >> Monitor input data from related sensors or check voltage of related module terminals using CONSULT.

DIAGNOSIS AND REPAIR WORKFLOW

< BASIC INSPECTION >

[HALOGEN HEADLAMP]

7. DETECT MALFUNCTIONING PART BY DIAGNOSTIC PROCEDURE

Inspect according to Diagnostic Procedure of the system.

Is malfunctioning part detected?

YES >> GO TO 8.

NO >> Check according to [GI-44. "Intermittent Incident"](#).

8. REPAIR OR REPLACE THE MALFUNCTIONING PART

1. Repair or replace the malfunctioning part.
2. Reconnect parts or connectors disconnected during Diagnostic Procedure again after repair and replacement.
3. Check DTC. If DTC is detected, erase it.

>> GO TO 9.

9. FINAL CHECK

When DTC is detected in step 2, perform DTC CONFIRMATION PROCEDURE again, and then check that the malfunction is repaired securely.

When symptom is described by the customer, refer to confirmed symptom in step 3 or 4, and check that the symptom is not detected.

Is DTC detected and does symptom remain?

YES-1 >> DTC is detected: GO TO 7.

YES-2 >> Symptom remains: GO TO 4.

NO >> Before returning the vehicle to the customer, always erase DTC.

A
B
C
D
E
F
G
H
I
J
K
EXL
M
N
O
P

INSPECTION AND ADJUSTMENT

ADDITIONAL SERVICE WHEN REPLACING CONTROL UNIT

ADDITIONAL SERVICE WHEN REPLACING CONTROL UNIT : Description

INFOID:000000011280733

CAUTION:

- When the IPDM E/R is replaced or disconnected and reconnected, perform “SENSOR INITIALIZE” with CONSULT.

ADDITIONAL SERVICE WHEN REPLACING CONTROL UNIT : Special Repair Requirement

INFOID:000000011280734

1.SENSOR INITIALIZE

ⓈCONSULT WORK SUPPORT

Perform “SENSOR INITIALIZE”. Refer to [EXL-84. "SENSOR INITIALIZE : Special Repair Requirement"](#).

>> Work End.

SENSOR INITIALIZE

SENSOR INITIALIZE : Description

INFOID:000000011280735

HEADLAMP AIMING CONTROL SYSTEM

Perform the sensor initialize when installing, removing and replacing the auto levelizer control unit or suspension components.

SENSOR INITIALIZE : Special Repair Requirement

INFOID:000000011280736

CAUTION:

When performing aiming adjustment after the levelizer initialization, be sure to start the engine after turning ignition switch OFF.

1.VEHICLE CONDITION CHECK

1. Park the vehicle in the straight-forward position.
2. Unload the vehicle (no passenger aboard).

>> GO TO 2.

2.SENSOR INITIALIZE

ⓈCONSULT WORK SUPPORT

1. Select “SENSOR INITIALIZE” in “Work Support” of “IPDM E/R”.
2. Select “START”.
3. When “INITIALIZE COMPLETE”, select “END”.

CAUTION:

If “INITIALIZE NOT DONE” is indicated, auto levelizer control unit detects that the sensor lever signal was changing. The sensor initialization is cancelled. In this case, turn the ignition switch OFF, do not allow the vehicle height to change. Perform the sensor initialization again.

Is the sensor initialize completed?

- YES >> GO TO 3.
NO >> Perform the sensor initialize again.

3.SELF DIAGNOSTIC RESULT CHECK

Perform the “Self Diagnostic Result” with CONSULT. Check that any DTC is not detected.

Is any DTC detected?

- YES >> GO TO 2.
NO >> Sensor initialize completed.

POWER SUPPLY AND GROUND CIRCUIT

< DTC/CIRCUIT DIAGNOSIS >

[HALOGEN HEADLAMP]

DTC/CIRCUIT DIAGNOSIS

POWER SUPPLY AND GROUND CIRCUIT

BCM (BODY CONTROL SYSTEM) (WITH INTELLIGENT KEY SYSTEM)

BCM (BODY CONTROL SYSTEM) (WITH INTELLIGENT KEY SYSTEM) : Diagnosis Procedure

INFOID:000000011393969

Regarding Wiring Diagram information, refer to [BCS-50. "Wiring Diagram"](#).

1. CHECK FUSE

Check that the following fuse is not blown.

Terminal No.	Signal name	Fuse No.
161	BCM power supply	7 (10A)

Is the fuse blown?

- YES >> Replace the blown fuse after repairing the affected circuit.
- NO >> GO TO 2.

2. CHECK POWER SUPPLY CIRCUIT

1. Disconnect BCM connector M20.
2. Check voltage between BCM connector M20 and ground.

BCM		Ground	Voltage (Approx.)
Connector	Terminal		
M20	161	—	Battery voltage

Is the inspection result normal?

- YES >> GO TO 3.
- NO >> Repair or replace harness or connectors.

3. CHECK GROUND CIRCUIT

Check continuity between BCM connector M20 and ground.

BCM		Ground	Continuity
Connector	Terminal		
M20	170	—	Yes
	171		

Is the inspection result normal?

- YES >> Inspection End.
- NO >> Repair or replace harness or connectors.

BCM (BODY CONTROL SYSTEM) (WITHOUT INTELLIGENT KEY SYSTEM)

BCM (BODY CONTROL SYSTEM) (WITHOUT INTELLIGENT KEY SYSTEM) : Diagnosis Procedure

INFOID:000000011393970

Regarding Wiring Diagram information, refer to [BCS-110. "Wiring Diagram"](#).

1. CHECK FUSE

POWER SUPPLY AND GROUND CIRCUIT

< DTC/CIRCUIT DIAGNOSIS >

[HALOGEN HEADLAMP]

Check that the following fuse is not blown.

Terminal No.	Signal name	Fuse No.
161	BCM power supply	7 (10A)

Is the fuse blown?

YES >> Replace the blown fuse after repairing the affected circuit.

NO >> GO TO 2.

2. CHECK POWER SUPPLY CIRCUIT

1. Disconnect BCM connector M20.
2. Check voltage between BCM connector M20 and ground.

BCM		Ground	Voltage (Approx.)
Connector	Terminal		
M20	161	—	Battery voltage

Is the inspection result normal?

YES >> GO TO 3.

NO >> Repair or replace harness or connectors.

3. CHECK GROUND CIRCUIT

Check continuity between BCM connector M20 and ground.

BCM		Ground	Continuity
Connector	Terminal		
M20	170	—	Yes
	171		

Is the inspection result normal?

YES >> Inspection End.

NO >> Repair or replace harness or connectors.

OPTICAL SENSOR

< DTC/CIRCUIT DIAGNOSIS >

[HALOGEN HEADLAMP]

OPTICAL SENSOR

Component Function Check

INFOID:0000000011280739

1.CHECK OPTICAL SENSOR SIGNAL BY CONSULT

CONSULT DATA MONITOR

1. Turn ignition switch ON.
2. Select "OPTICAL SENSOR" in "Data Monitor" of "BCM (HEADLAMP)".
3. Turn lighting switch AUTO.
4. With the optical sensor illuminating, check the monitor status.

Monitor item	Condition		Voltage (Approx.)
OPTICAL SENSOR	Optical sensor	When illuminating	3.1 V or more *
		When shutting off light	0.6 V or less

*: Illuminates the optical sensor. The value may be less than the standard value if brightness is weak.

Is the inspection result normal?

- YES >> Optical sensor is normal.
 NO >> Refer to [EXL-87, "Diagnosis Procedure"](#).

Diagnosis Procedure

INFOID:0000000011280740

1.CHECK OPTICAL SENSOR POWER SUPPLY INPUT

1. Turn ignition switch ON.
2. Turn lighting switch AUTO.
3. Check voltage between optical sensor harness connector and ground.

(+)		(-)	Voltage (Approx.)
Optical sensor			
Connector	Terminal		
M13	1	Ground	5 V

Is the inspection result normal?

- YES >> GO TO 2.
 NO >> GO TO 4.

2.CHECK OPTICAL SENSOR GROUND INPUT

Check voltage between optical sensor harness connector and ground.

(+)		(-)	Voltage (Approx.)
Optical sensor			
Connector	Terminal		
M13	3	Ground	0 V

Is the inspection result normal?

- YES >> GO TO 3.
 NO >> GO TO 6.

3.CHECK OPTICAL SENSOR SIGNAL OUTPUT

With illuminating the optical sensor, check voltage between optical sensor harness connector and ground.

OPTICAL SENSOR

[HALOGEN HEADLAMP]

< DTC/CIRCUIT DIAGNOSIS >

(+)		(-)	Condition	Voltage (Approx.)
Optical sensor				
Connector	Terminal			
M13	2	Ground	Optical sensor	When illuminating 3.1 V or more *
				When shutting off light 0.6 V or less

*: Illuminate the optical sensor. The value may be less than the standard if brightness is weak.

Is the inspection result normal?

YES >> GO TO 7.

NO >> Replace the optical sensor.

4.CHECK OPTICAL SENSOR OPEN CIRCUIT

1. Turn ignition switch OFF.
2. Disconnect optical sensor connector and BCM connector.
3. Check continuity between optical sensor harness connector and BCM harness connector.

Optical sensor		BCM		Continuity
Connector	Terminal	Connector	Terminal	
M13	1	M18	12	Yes

Is the inspection result normal?

YES >> GO TO 5.

NO >> Repair or replace harness.

5.CHECK OPTICAL SENSOR SHORT CIRCUIT

Check continuity between optical sensor harness connector and ground.

Optical sensor		Ground	Continuity
Connector	Terminal		
M13	1		No

Is the inspection result normal?

YES >> Replace BCM. Refer to [BCS-75. "Removal and Installation"](#) (with Intelligent Key system) or [BCS-135. "Removal and Installation"](#) (without Intelligent Key system).

NO >> Repair or replace harness.

6.CHECK OPTICAL SENSOR GROUND OPEN CIRCUIT

1. Turn ignition switch OFF.
2. Disconnect optical sensor connector and BCM connector.
3. Check continuity between optical sensor harness connector and BCM harness connector.

Optical sensor		BCM		Continuity
Connector	Terminal	Connector	Terminal	
M13	3	M18	30	Yes

Is the inspection result normal?

YES >> Replace BCM. Refer to [BCS-75. "Removal and Installation"](#) (with Intelligent Key system) or [BCS-135. "Removal and Installation"](#) (without Intelligent Key system).

NO >> Repair or replace harness.

7.CHECK OPTICAL SENSOR SIGNAL OPEN CIRCUIT

1. Turn ignition switch OFF.
2. Disconnect optical sensor connector and BCM connector.
3. Check continuity between optical sensor harness connector and BCM harness connector.

OPTICAL SENSOR

< DTC/CIRCUIT DIAGNOSIS >

[HALOGEN HEADLAMP]

Optical sensor		BCM		Continuity
Connector	Terminal	Connector	Terminal	
M13	2	M18	19	Yes

Is the inspection result normal?

YES >> GO TO 8.

NO >> Repair or replace harness.

8. CHECK OPTICAL SENSOR SHORT CIRCUIT

Check continuity between optical sensor harness connector and ground.

Optical sensor		Ground	Continuity
Connector	Terminal		
M13	2		No

Is the inspection result normal?

YES >> Replace BCM. Refer to [BCS-75, "Removal and Installation"](#) (with Intelligent Key system) or [BCS-135, "Removal and Installation"](#) (without Intelligent Key system).

NO >> Repair or replace harness.

A
B
C
D
E
F
G
H
I
J
K
EXL
M
N
O
P

HAZARD SWITCH

< DTC/CIRCUIT DIAGNOSIS >

[HALOGEN HEADLAMP]

HAZARD SWITCH

Component Function Check

INFOID:000000011280741

1. CHECK HAZARD SWITCH SIGNAL BY CONSULT

CONSULT DATA MONITOR

1. Turn ignition switch ON.
2. Select "HAZARD SW" in "Data Monitor" of "BCM (FLASHER)".
3. With operating the hazard switch, check the monitor status.

Monitor item	Condition		Monitor status
HAZARD SW	Hazard switch	ON	On
		OFF	Off

Is the inspection result normal?

- YES >> Hazard switch circuit is normal.
NO >> Refer to [EXL-90, "Diagnosis Procedure"](#).

Diagnosis Procedure

INFOID:000000011280742

1. CHECK HAZARD SWITCH SIGNAL INPUT

1. Turn ignition switch OFF.
2. Disconnect hazard switch connector.
3. Check voltage between hazard switch connector and ground.

(+)		(-)	Voltage (Approx.)
Hazard switch			
Connector	Terminal	Ground	Battery voltage
M26	2		

Is the inspection result normal?

- YES >> GO TO 4.
NO >> GO TO 2.

2. CHECK HAZARD SWITCH SIGNAL OPEN CIRCUIT

1. Disconnect BCM connector.
2. Check continuity between hazard switch harness connector and BCM harness connector.

Hazard switch		BCM		Continuity
Connector	Terminal	Connector	Terminal	
M26	2	M18	11	Yes

Is the inspection result normal?

- YES >> GO TO 3.
NO >> Repair or replace harness.

3. CHECK HAZARD SWITCH SIGNAL SHORT CIRCUIT

Check continuity between hazard switch harness connector and ground.

Hazard switch		Ground	Continuity
Connector	Terminal		
M26	2		No

Is the inspection result normal?

- YES >> Replace BCM. Refer to [BCS-75, "Removal and Installation"](#) (with Intelligent Key system) or [BCS-135, "Removal and Installation"](#) (without Intelligent Key system).
NO >> Repair or replace harness.

HAZARD SWITCH

< DTC/CIRCUIT DIAGNOSIS >

[HALOGEN HEADLAMP]

4. CHECK HAZARD SWITCH GROUND OPEN CIRCUIT

Check continuity between hazard switch harness connector and ground.

Hazard switch		Ground	Continuity
Connector	Terminal		
M26	3		Yes

Is the inspection result normal?

YES >> Replace hazard switch. Refer to [EXL-125, "Removal and Installation"](#).

NO >> Repair or replace harness.

A
B
C
D
E
F
G
H
I
J
K
L
M
N
O
P

EXL

TURN SIGNAL LAMP CIRCUIT

< DTC/CIRCUIT DIAGNOSIS >

[HALOGEN HEADLAMP]

TURN SIGNAL LAMP CIRCUIT

Description

INFOID:000000011421526

The BCM monitors inputs from the combination switch (lighting and turn signal switch) to determine when to activate the turn signals. The BCM outputs voltage direction to the left and right turn signals during turn signal operation or both during hazard warning operation. The BCM sends a turn signal indicator request to the combination meter via the CAN communication lines.

The BCM performs the fast flasher operation (fail-safe) if any bulb or harness of the turn signal lamp circuit is open.

NOTE:

Turn signal lamp blinks at normal speed when using the hazard warning lamp.

Component Function Check

INFOID:000000011421527

1. CHECK TURN SIGNAL LAMP

CONSULT

1. Select "FLASHER" in "Active Test" of "BCM (FLASHER)".
2. While operating the test items, check that the turn signal lamp blinks.

LH : Turn signal lamps (LH) ON
RH : Turn signal lamps (RH) ON
Off : Turn signal lamps OFF

Is the inspection result normal?

- YES >> Turn signal lamp circuit is normal.
NO >> Refer to [EXL-92. "Diagnosis Procedure"](#).

Diagnosis Procedure

INFOID:000000011421528

Regarding Wiring Diagram information, refer to [EXL-55. "Wiring Diagram"](#).

1. CHECK TURN SIGNAL LAMP BULB

Check the applicable lamp bulb to be sure the proper bulb standard is in use and the bulb is not open.

Is the bulb OK?

- YES >> GO TO 2.
NO >> Replace the bulb.

2. CHECK TURN SIGNAL LAMP OUTPUT VOLTAGE

1. Turn the ignition switch OFF.
2. Disconnect the front combination lamp harness connector, door mirror harness connector or the side turn signal harness connector or the rear combination lamp harness connector in question.
3. Turn the ignition switch ON.
4. Operate the turn signal switch.
5. While the turn signal is operating, check the voltage between the front combination lamp harness connector and ground.

(+)		(-)	Voltage (Approx.)
Connector	Terminal		

TURN SIGNAL LAMP CIRCUIT

< DTC/CIRCUIT DIAGNOSIS >

[HALOGEN HEADLAMP]

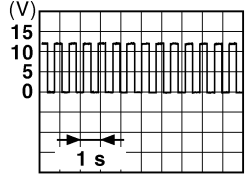
LH	E105			
RH	E103	1	Ground	 <small>PKID0926E</small>

6. While the turn signal is operating, check the voltage between the door mirror harness connector and ground.

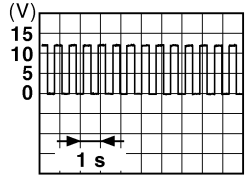
(+)		Terminal	(-)	Voltage (Approx.)
Connector				
LH	D14		Ground	 <small>PKID0926E</small>
RH	D107			

7. While the turn signal is operating, check the voltage between the rear combination lamp harness connector and ground.

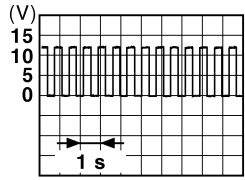
(+)		Terminal	(-)	Voltage (Approx.)
Connector				
LH	B90	3	Ground	 <small>PKID0926E</small>
RH	B102			

Are the inspection results normal?

- YES >> GO TO 5.
- NO >> GO TO 3.

3. CHECK TURN SIGNAL LAMP CIRCUIT FOR OPEN

1. Turn the ignition switch OFF.
2. Disconnect BCM harness connector E29, M18 or B23.
3. Check continuity between the BCM harness connector E29 and the front combination lamp harness connector.

BCM			Front combination lamp		Continuity
Connector		Terminal	Connector	Terminal	
LH	E29	135	E105	1	Yes
RH		136	E103		

4. Check continuity between the BCM harness connector B23 and the door mirror harness connector.

BCM			Door mirror		Continuity
Connector		Terminal	Connector	Terminal	
LH	M18	2	D14	13	Yes
RH		3	D107		

A
B
C
D
E
F
G
H
I
J
K
M
N
O
P

EXL

TURN SIGNAL LAMP CIRCUIT

[HALOGEN HEADLAMP]

< DTC/CIRCUIT DIAGNOSIS >

5. Check continuity between the BCM harness connector B23 and the rear combination lamp harness connector.

BCM			Rear combination lamp		Continuity
Connector		Terminal	Connector	Terminal	
LH	B23	157	B90	3	Yes
RH		160	B102		

Are the inspection results normal?

YES >> GO TO 4.

NO >> Repair or replace the harness or connectors.

4. CHECK TURN SIGNAL LAMP SHORT CIRCUIT

1. Check continuity between the BCM harness connector E29 and ground.

BCM			Ground	Continuity
Connector		Terminal		
LH	E29	135		No
RH		136		

2. Check continuity between the BCM harness connector M18 and ground.

BCM			Ground	Continuity
Connector		Terminal		
LH	B18	2		No
RH		3		

3. Check continuity between the BCM harness connector M23 and ground.

BCM			Ground	Continuity
Connector		Terminal		
LH	B23	157		No
RH		160		

Are the inspection results normal?

YES >> Replace BCM. Refer to [BCS-75. "Removal and Installation"](#) (with Intelligent Key system) or [BCS-135. "Removal and Installation"](#) (without Intelligent Key system).

NO >> Repair or replace the harness or connectors.

5. CHECK TURN SIGNAL LAMP GROUND CIRCUIT

1. Turn the ignition switch OFF.
2. Check continuity between the front combination lamp harness connector, the door mirror connector or the rear combination lamp harness connector in question and ground.

Front combination lamp			(-)	Continuity
Connector		Terminal		
LH	E105	2	Ground	Yes
RH	E103			

3. Check continuity between the door mirror harness connector and ground.

Door mirror			(-)	Continuity
Connector		Terminal		

TURN SIGNAL LAMP CIRCUIT

< DTC/CIRCUIT DIAGNOSIS >

[HALOGEN HEADLAMP]

LH	D14	14	Ground	Yes
RH	D107			

A

4. Check continuity between the rear combination lamp harness connector and ground.

B

Rear combination lamp		Terminal	(-)	Continuity
Connector				
LH	B90	4	Ground	Yes
RH	B102			

C

Are the inspection results normal?

D

- YES >> Replace the malfunctioning lamp.
- NO >> Repair or replace the harness or connectors.

E

F

G

H

I

J

K

EXL

M

N

O

P

B121A FRONT FOG LAMP LH POWER SUPPLY CIRCUIT

< DTC/CIRCUIT DIAGNOSIS >

[HALOGEN HEADLAMP]

B121A FRONT FOG LAMP LH POWER SUPPLY CIRCUIT

DTC Logic

INFOID:000000011280746

DTC DETECTION LOGIC

DTC	Display Item	Malfunction detected condition	Possible causes
B121A	FR FOG LAMP LH PWR SPLY CIRC [CIRC SHORT TO GROUND]	Short to ground	<ul style="list-style-type: none"> IPDM E/R Short to ground

DTC CONFIRMATION PROCEDURE

1. CHECK SELF DIAGNOSTIC RESULT

 With CONSULT.

- Turn ignition switch ON.
- Perform "Self Diagnostic Result".

Is DTC B121A detected?

- YES >> Proceed to diagnosis procedure. Refer to [EXL-96, "Diagnosis Procedure"](#).
 NO >> Inspection End.

Diagnosis Procedure

INFOID:000000011280747

1. CHECK FOG LAMP SHORT CIRCUIT TO GROUND

- Disconnect fog lamp connector and IPDM E/R connector.
- Check continuity between IPDM E/R harness connector and ground.

IPDM E/R		Ground	Continuity
Connector	Terminal		
E217	51		No

Is the inspection result normal?

- YES >> GO TO 2.
 NO >> Repair or replace harness.

2. CHECK FOG LAMP SHORT CIRCUIT TO GROUND

- Reconnect IPDM E/R connector.
- Check continuity between fog lamp harness connector and ground.

Fog lamp			Ground	Continuity
Connector	Terminal			
LH	E222	1		No

Is the inspection result normal?

- YES >> Refer to [GI-44, "Intermittent Incident"](#).
 NO >> Replace IPDM E/R. Refer to [PCS-40, "Removal and Installation"](#).

B1231 DAYTIME RUNNING LIGHT RH POWER SUPPLY CIRCUIT

< DTC/CIRCUIT DIAGNOSIS >

[HALOGEN HEADLAMP]

B1231 DAYTIME RUNNING LIGHT RH POWER SUPPLY CIRCUIT

DTC Logic

INFOID:000000011280748

DTC DETECTION LOGIC

DTC	Display Item	Malfunction detected condition	Possible causes
B1231	DTRL RH PWR SPLY CIRC [CIRC SHORT TO GRND]	When a short circuit to ground in the daytime running lamp circuit is detected.	<ul style="list-style-type: none"> IPDM E/R Short to ground

DTC CONFIRMATION PROCEDURE

1. CHECK SELF DIAGNOSTIC RESULT

 With CONSULT.

1. Turn ignition switch ON.

2. Perform "Self Diagnostic Result".

Is DTC B1231 detected?

YES >> Proceed to diagnosis procedure. Refer to [EXL-97, "Diagnosis Procedure"](#).

NO >> Inspection End.

Diagnosis Procedure

INFOID:000000011280749

1. CHECK FRONT COMBINATION LAMP SHORT CIRCUIT TO GROUND

1. Disconnect front combination lamp connector and IPDM E/R connector.

2. Check continuity between IPDM E/R harness connector and ground.

IPDM E/R		Ground	Continuity
Connector	Terminal		
E218	58		No

Is the inspection result normal?

YES >> GO TO 2.

NO >> Repair or replace harness.

2. CHECK FRONT COMBINATION LAMP SHORT CIRCUIT TO GROUND

1. Reconnect IPDM E/R connector.

2. Check continuity between front combination lamp harness connector and ground.

Front combination lamp			Ground	Continuity
Connector	Terminal			
RH	E234	10		No

Is the inspection result normal?

YES >> Refer to [GI-44, "Intermittent Incident"](#).

NO >> Replace IPDM E/R. Refer to [PCS-40, "Removal and Installation"](#).

B1256 FRONT FOG LAMP RH POWER SUPPLY CIRCUIT

< DTC/CIRCUIT DIAGNOSIS >

[HALOGEN HEADLAMP]

B1256 FRONT FOG LAMP RH POWER SUPPLY CIRCUIT

DTC Logic

INFOID:000000011280750

DTC DETECTION LOGIC

DTC	Display Item	Malfunction detected condition	Possible causes
B1256	FR FOG LAMP RH PWR SPLY CIRC [CIRC SHORT TO GRND]	When a short circuit to ground is detected.	<ul style="list-style-type: none">IPDM E/RShort to ground

DTC CONFIRMATION PROCEDURE

1. CHECK SELF DIAGNOSTIC RESULT

Ⓜ With CONSULT.

- Turn ignition switch ON.
- Perform "Self Diagnostic Result".

Is DTC B1256 detected?

- YES >> Proceed to diagnosis procedure. Refer to [EXL-98, "Diagnosis Procedure"](#).
NO >> Inspection End.

Diagnosis Procedure

INFOID:000000011280751

1. CHECK FOG LAMP SHORT CIRCUIT TO GROUND

- Disconnect fog lamp connector and IPDM E/R connector.
- Check continuity between IPDM E/R harness connector and ground.

IPDM E/R		Ground	Continuity
Connector	Terminal		
E218	57		No

Is the inspection result normal?

- YES >> GO TO 2.
NO >> Repair or replace harness.

2. CHECK FOG LAMP SHORT CIRCUIT TO GROUND

- Reconnect IPDM E/R connector.
- Check continuity between fog lamp harness connector and ground.

Fog lamp			Ground	Continuity
Connector	Terminal			
RH	E221	1		No

Is the inspection result normal?

- YES >> Refer to [GI-44, "Intermittent Incident"](#).
NO >> Replace IPDM E/R. Refer to [PCS-40, "Removal and Installation"](#).

B20CB DAYTIME RUNNING LIGHT LH POWER SUPPLY CIRCUIT

< DTC/CIRCUIT DIAGNOSIS >

[HALOGEN HEADLAMP]

B20CB DAYTIME RUNNING LIGHT LH POWER SUPPLY CIRCUIT

DTC Logic

INFOID:000000011280752

DTC DETECTION LOGIC

DTC	Display Item	Malfunction detected condition	Possible causes
B02CB	DTRL LH PWR SPLY CIRC [CIRC SHORT TO GRND]	When a short circuit to ground is detected.	<ul style="list-style-type: none">IPDM E/RShort to ground

DTC CONFIRMATION PROCEDURE

1. CHECK SELF DIAGNOSTIC RESULT

 With CONSULT.

1. Turn ignition switch ON.

2. Perform "Self Diagnostic Result".

Is DTC B02CB detected?

YES >> Proceed to diagnosis procedure. Refer to [EXL-99, "Diagnosis Procedure"](#).

NO >> Inspection End.

Diagnosis Procedure

INFOID:000000011280753

1. CHECK FRONT COMBINATION LAMP SHORT CIRCUIT TO GROUND

1. Disconnect front combination lamp connector and IPDM E/R connector.

2. Check continuity between IPDM E/R harness connector and ground.

IPDM E/R		Ground	Continuity
Connector	Terminal		
E217	49		No

Is the inspection result normal?

YES >> GO TO 2.

NO >> Repair or replace harness.

2. CHECK FRONT COMBINATION LAMP SHORT CIRCUIT TO GROUND

1. Reconnect IPDM E/R connector.

2. Check continuity between fog lamp harness connector and ground.

Front combination lamp			Ground	Continuity
Connector		Terminal		
LH	E236	10		No

Is the inspection result normal?

YES >> Refer to [GI-44, "Intermittent Incident"](#).

NO >> Replace IPDM E/R. Refer to [PCS-40, "Removal and Installation"](#).

B20CE HEADLAMP (HI) LH POWER SUPPLY CIRCUIT

< DTC/CIRCUIT DIAGNOSIS >

[HALOGEN HEADLAMP]

B20CE HEADLAMP (HI) LH POWER SUPPLY CIRCUIT

DTC Logic

INFOID:000000011280754

DTC DETECTION LOGIC

DTC	Display Item	Malfunction detected condition	Possible causes
B20CE	DTRL LH PWR SPLY CIRC [CIRC SHORT TO GRND]	Short to ground	<ul style="list-style-type: none">IPDM E/RShort to ground

DTC CONFIRMATION PROCEDURE

1.CHECK SELF DIAGNOSTIC RESULT

Ⓜ With CONSULT.

- Turn ignition switch ON.
- Perform "Self Diagnostic Result".

Is DTC B20CE detected?

- YES >> Proceed to diagnosis procedure. Refer to [EXL-100, "Diagnosis Procedure"](#).
NO >> Inspection End.

Diagnosis Procedure

INFOID:000000011280755

1.CHECK HEAD LAMP SHORT CIRCUIT TO GROUND

- Disconnect front combination lamp connector and IPDM E/R connector.
- Check continuity between IPDM E/R harness connector and ground.

IPDM E/R		Ground	Continuity
Connector	Terminal		
E218	59		No

Is the inspection result normal?

- YES >> GO TO 2.
NO >> Repair or replace harness.

2.CHECK HEAD LAMP SHORT CIRCUIT TO GROUND

- Reconnect IPDM E/R connector.
- Check continuity between front combination lamp harness connector and ground.

Front combination lamp			Ground	Continuity
Connector	Terminal			
LH	E236	15		No

Is the inspection result normal?

- YES >> Refer to [GI-44, "Intermittent Incident"](#).
NO >> Replace IPDM E/R. Refer to [PCS-40, "Removal and Installation"](#).

B20CF HEADLAMP (HI) RH POWER SUPPLY CIRCUIT

< DTC/CIRCUIT DIAGNOSIS >

[HALOGEN HEADLAMP]

B20CF HEADLAMP (HI) RH POWER SUPPLY CIRCUIT

DTC Logic

INFOID:000000011280756

DTC DETECTION LOGIC

DTC	Display Item	Malfunction detected condition	Possible causes
B20CF	HL (HI) RH PWR SPLY CIRC [CIRC SHORT TO GRND]	Short to ground	<ul style="list-style-type: none"> IPDM E/R Short to ground

DTC CONFIRMATION PROCEDURE

1. CHECK SELF DIAGNOSTIC RESULT

 With CONSULT.

1. Turn ignition switch ON.

2. Perform "Self Diagnostic Result".

Is DTC B20CF detected?

YES >> Proceed to diagnosis procedure. Refer to [EXL-101, "Diagnosis Procedure"](#).

NO >> Inspection End.

Diagnosis Procedure

INFOID:000000011280757

1. CHECK HEAD LAMP SHORT CIRCUIT TO GROUND

1. Disconnect front combination lamp connector and IPDM E/R connector.

2. Check continuity between IPDM E/R harness connector and ground.

IPDM E/R		Ground	Continuity
Connector	Terminal		
E217	54		No

Is the inspection result normal?

YES >> GO TO 2.

NO >> Repair or replace harness.

2. CHECK HEAD LAMP SHORT CIRCUIT TO GROUND

1. Reconnect IPDM E/R connector.

2. Check continuity between front combination lamp harness connector and ground.

Front combination lamp			Ground	Continuity
Connector	Terminal			
RH	E234	15		No

Is the inspection result normal?

YES >> Refer to [GI-44, "Intermittent Incident"](#).

NO >> Replace IPDM E/R. Refer to [PCS-40, "Removal and Installation"](#).

B20D0 HEADLAMP (LO) LH POWER SUPPLY CIRCUIT

< DTC/CIRCUIT DIAGNOSIS >

[HALOGEN HEADLAMP]

B20D0 HEADLAMP (LO) LH POWER SUPPLY CIRCUIT

DTC Logic

INFOID:000000011280758

DTC DETECTION LOGIC

DTC	Display Item	Malfunction detected condition	Possible causes
B20D0	HI (LO) RH PWR SPLY CIRC [CIRC SHORT TO GRND]	Short to ground	<ul style="list-style-type: none">IPDM E/RShort to ground

DTC CONFIRMATION PROCEDURE

1. CHECK SELF DIAGNOSTIC RESULT

 With CONSULT.

- Turn ignition switch ON.
- Perform "Self Diagnostic Result".

Is DTC B20D0 detected?

- YES >> Proceed to diagnosis procedure. Refer to [EXL-102, "Diagnosis Procedure"](#).
NO >> Inspection End.

Diagnosis Procedure

INFOID:000000011280759

1. CHECK FRONT COMBINATION LAMP SHORT CIRCUIT TO GROUND

- Disconnect front combination lamp connector and IPDM E/R connector.
- Check continuity between IPDM E/R harness connector and ground.

IPDM E/R		Ground	Continuity
Connector	Terminal		
E217	50		No

Is the inspection result normal?

- YES >> GO TO 2.
NO >> Repair or replace harness.

2. CHECK FRONT COMBINATION LAMP SHORT CIRCUIT TO GROUND

- Reconnect IPDM E/R connector.
- Check continuity between front combination lamp harness connector and ground.

Front combination lamp			Ground	Continuity
Connector		Terminal		
LH	E235	4		No

Is the inspection result normal?

- YES >> Refer to [GI-44, "Intermittent Incident"](#).
NO >> Replace IPDM E/R. Refer to [PCS-40, "Removal and Installation"](#).

B20D1 HEADLAMP (LO) RH POWER SUPPLY CIRCUIT

< DTC/CIRCUIT DIAGNOSIS >

[HALOGEN HEADLAMP]

B20D1 HEADLAMP (LO) RH POWER SUPPLY CIRCUIT

DTC Logic

INFOID:000000011280760

DTC DETECTION LOGIC

DTC	Display Item	Malfunction detected condition	Possible causes
B20D1	HL (LO) RH PWR SPLY CIRC [CIRC SHORT TO GRND]	Short to ground	<ul style="list-style-type: none"> IPDM E/R Short to ground

DTC CONFIRMATION PROCEDURE

1. CHECK SELF DIAGNOSTIC RESULT

 With CONSULT.

1. Turn ignition switch ON.

2. Perform "Self Diagnostic Result".

Is DTC B20D1 detected?

YES >> Proceed to diagnosis procedure. Refer to [EXL-103, "Diagnosis Procedure"](#).

NO >> Inspection End.

Diagnosis Procedure

INFOID:000000011280761

1. CHECK FRONT COMBINATION LAMP SHORT CIRCUIT TO GROUND

1. Disconnect front combination lamp connector and IPDM E/R connector.

2. Check continuity between IPDM E/R harness connector and ground.

IPDM E/R		Ground	Continuity
Connector	Terminal		
E218	62		No

Is the inspection result normal?

YES >> GO TO 2.

NO >> Repair or replace harness.

2. CHECK FRONT COMBINATION LAMP SHORT CIRCUIT TO GROUND

1. Reconnect IPDM E/R connector.

2. Check continuity between fog lamp harness connector and ground.

Front combination lamp			Ground	Continuity
Connector	Terminal			
RH	E233	4		No

Is the inspection result normal?

YES >> Refer to [GI-44, "Intermittent Incident"](#).

NO >> Replace IPDM E/R. Refer to [PCS-40, "Removal and Installation"](#).

B20D2 PARKING LAMP POWER SUPPLY CIRCUIT

< DTC/CIRCUIT DIAGNOSIS >

[HALOGEN HEADLAMP]

B20D2 PARKING LAMP POWER SUPPLY CIRCUIT

DTC Logic

INFOID:000000011280762

DTC DETECTION LOGIC

DTC	Display Item	Malfunction detected condition	Possible causes
B20D2	PARKING LAMP PWR SPLY CIRC [CIRC SHORT TO GROUND]	When a short to ground is detected in the parking lamp power supply circuit.	• Short to ground

DTC CONFIRMATION PROCEDURE

1. CHECK SELF DIAGNOSTIC RESULT

Ⓜ With CONSULT.

1. Turn ignition switch ON.
2. Perform "Self Diagnostic Result".

Is DTC B20D2 detected?

- YES >> Proceed to diagnosis procedure. Refer to [EXL-104, "Diagnosis Procedure"](#).
NO >> Inspection End.

Diagnosis Procedure

INFOID:000000011280763

1. CHECK FRONT COMBINATION LAMP SHORT CIRCUIT TO GROUND

1. Disconnect front combination lamp connectors and IPDM E/R connector.
2. Check continuity between IPDM E/R harness connector and ground.

IPDM E/R			Ground	Continuity
Connector		Terminal		
LH	E217	56	Ground	No
RH	E218	61		

Is the inspection result normal?

- YES >> GO TO 2.
NO >> Repair or replace harness.

2. CHECK FRONT COMBINATION LAMP SHORT CIRCUIT TO GROUND

1. Reconnect IPDM E/R connector.
2. Check continuity between front combination lamp harness connector and ground.

IPDM E/R			Ground	Continuity
Connector		Terminal		
LH	E236 (parking lamp)	12	Ground	No
	E235 (side marker lamp)	9		
RH	E234 (parking lamp)	12		
	E233 (side marker lamp)	9		

Is the inspection result normal?

- YES >> Refer to [GI-44, "Intermittent Incident"](#).
NO >> Replace IPDM E/R. Refer to [PCS-40, "Removal and Installation"](#).

B20D4 TAIL LAMP LH POWER SUPPLY CIRCUIT

< DTC/CIRCUIT DIAGNOSIS >

[HALOGEN HEADLAMP]

B20D4 TAIL LAMP LH POWER SUPPLY CIRCUIT

DTC Logic

INFOID:000000011280764

DTC DETECTION LOGIC

DTC	Display Item	Malfunction detected condition	Possible causes
B20D4	TAIL LAMP LH PWR SPLY CIRC [CIRC SHORT TO GRND]	Short to ground	<ul style="list-style-type: none"> IPDM E/R Short to ground

DTC CONFIRMATION PROCEDURE

1. CHECK SELF DIAGNOSTIC RESULT

Ⓜ With CONSULT.

- Turn ignition switch ON.
- Perform "Self Diagnostic Result".

Is DTC B20D4 detected?

- YES >> Proceed to diagnosis procedure. Refer to [EXL-105, "Diagnosis Procedure"](#).
 NO >> Inspection End.

Diagnosis Procedure

INFOID:000000011280765

1. CHECK TAIL LAMP SHORT CIRCUIT TO GROUND

- Disconnect rear combination lamp (LH), license plate lamps, back up lamp connectors and IPDM E/R connector.
- Check continuity between IPDM E/R harness connector and ground.

IPDM E/R		Ground	Continuity
Connector	Terminal		
E119	4		No

Is the inspection result normal?

- YES >> GO TO 2.
 NO >> Repair or replace harness.

2. CHECK TAIL LAMP SHORT CIRCUIT TO GROUND

- Reconnect IPDM E/R connector.
- Check continuity between rear combination lamp harness connector and ground.

Rear combination lamp			Ground	Continuity
Connector	Terminal			
LH	B90	1		No

Is the inspection result normal?

- YES >> Refer to [GI-44, "Intermittent Incident"](#).
 NO >> Replace IPDM E/R. Refer to [PCS-40, "Removal and Installation"](#).

A
B
C
D
E
F
G
H
I
J
K
EXL
M
N
O
P

B20D5 TAIL LAMP RH POWER SUPPLY CIRCUIT

< DTC/CIRCUIT DIAGNOSIS >

[HALOGEN HEADLAMP]

B20D5 TAIL LAMP RH POWER SUPPLY CIRCUIT

DTC Logic

INFOID:000000011280766

DTC DETECTION LOGIC

DTC	Display Item	Malfunction detected condition	Possible causes
B20D5	TAIL LAMP RH PWR SPLY CIRC [CIRC SHORT TO GRND]	When a short circuit to ground is detected in the tail lamp supply voltage circuit.	<ul style="list-style-type: none">• IPDM E/R• Short to ground

DTC CONFIRMATION PROCEDURE

1. CHECK SELF DIAGNOSTIC RESULT

Ⓜ With CONSULT.

1. Turn ignition switch ON.
2. Perform "Self Diagnostic Result".

Is DTC B20D5 detected?

- YES >> Proceed to diagnosis procedure. Refer to [EXL-106, "Diagnosis Procedure"](#).
NO >> Inspection End.

Diagnosis Procedure

INFOID:000000011280767

1. CHECK TAIL LAMP SHORT CIRCUIT TO GROUND

1. Disconnect rear combination lamp (RH), back up lamp connectors and IPDM E/R connector.
2. Check continuity between IPDM E/R harness connector and ground.

IPDM E/R		Ground	Continuity
Connector	Terminal		
E119	17		No

Is the inspection result normal?

- YES >> GO TO 2.
NO >> Repair or replace harness.

2. CHECK TAIL LAMP SHORT CIRCUIT TO GROUND

1. Reconnect IPDM E/R connector.
2. Check continuity between rear combination lamp harness connector and ground.

Rear combination lamp			Ground	Continuity
Connector		Terminal		
RH	B102	1		No

Is the inspection result normal?

- YES >> Refer to [GI-44, "Intermittent Incident"](#).
NO >> Replace IPDM E/R. Refer to [PCS-40, "Removal and Installation"](#).

EXTERIOR LIGHTING SYSTEM SYMPTOMS

< SYMPTOM DIAGNOSIS >

[HALOGEN HEADLAMP]

SYMPTOM DIAGNOSIS

EXTERIOR LIGHTING SYSTEM SYMPTOMS

Symptom Table

INFOID:000000011280768

CAUTION:

Perform the “Self Diagnostic Result” with CONSULT before the symptom diagnosis. Perform the trouble diagnosis if any DTC is detected.

Symptom		Possible cause	Inspection item
Headlamp (HI) is not turned ON.	One side	<ul style="list-style-type: none"> • Fuse • Halogen bulb (HI) • Harness between IPDM E/R and headlamp (HI) • Harness between headlamp (HI) and ground • IPDM E/R 	Headlamp (HI) circuit Refer to EXL-100, "DTC Logic" (LH) or EXL-101, "DTC Logic" (RH).
	Both sides	<p>Symptom diagnosis “BOTH SIDE HEADLAMPS (HI) ARE NOT TURNED ON” Refer to EXL-100, "DTC Logic" (LH) or EXL-101, "DTC Logic" (RH).</p>	
High beam indicator lamp is not turned ON. [Headlamp (HI) is turned ON.]		Combination meter	<ul style="list-style-type: none"> • Combination meter “Data Monitor” “HI-BEAM IND” • BCM (HEAD LAMP) “Active Test” “HEADLAMP”
Headlamp (LO) is not turned ON.	One side	<ul style="list-style-type: none"> • Fuse • Halogen bulb (LO) • Harness between IPDM E/R and headlamp lamp (LO) • Harness between headlamp (LO) and ground • IPDM E/R 	Headlamp (LO) circuit Refer to EXL-102, "DTC Logic" (LH) or EXL-103, "DTC Logic" (RH).
	Both sides	<p>Symptom diagnosis “BOTH SIDE HEADLAMPS (LO) ARE NOT TURNED ON” Refer to EXL-102, "DTC Logic" (LH) or EXL-103, "DTC Logic" (RH).</p>	
Each lamp is not turned ON/OFF with lighting switch AUTO.		<ul style="list-style-type: none"> • Combination switch • Harness between combination switch and BCM • BCM 	Combination switch Refer to BCS-73, "Symptom Table" (with Intelligent Key system) or BCS-133, "Symptom Table" (without Intelligent Key system).
		<ul style="list-style-type: none"> • Optical sensor • Harness between optical sensor and BCM • BCM 	Optical sensor Refer to EXL-87, "Component Function Check" .
Daytime running light is not turned ON. [Headlamp (HI) is turned ON.]		<ul style="list-style-type: none"> • Fuse • Harness between IPDM E/R and front combination lamp • IPDM E/R • BCM • ECM • Combination meter 	<ul style="list-style-type: none"> • Daytime running light circuit Refer to EXL-97, "DTC Logic". • BCM (HEADLAMP) “Data Monitor” “ENGINE STATE” • Combination meter “Data Monitor” “PKB SW” • BCM (HEADLAMP) “Active Test” “DAYTIME RUNNING LIGHT”
Parking lamp is not turned ON.		<ul style="list-style-type: none"> • Fuse • Parking lamp bulb • Harness between IPDM E/R and front combination lamp • IPDM E/R 	Parking lamp circuit Refer to EXL-104, "DTC Logic" .

A
B
C
D
E
F
G
H
I
J
K
M
N
O
P

EXL

EXTERIOR LIGHTING SYSTEM SYMPTOMS

< SYMPTOM DIAGNOSIS >

[HALOGEN HEADLAMP]

Symptom	Possible cause	Inspection item	
Front side marker lamp is not turned ON.	<ul style="list-style-type: none"> • Front side marker lamp bulb • Harness between IPDM E/R and front side marker lamp • Harness between front side marker lamp and ground • IPDM E/R 	Front side marker lamp circuit Refer to EXL-104, "DTC Logic" .	
License plate lamp is not turned ON.	<ul style="list-style-type: none"> • License plate lamp bulb • Harness between IPDM E/R and license plate lamp • Harness between license plate lamp and ground 	License plate lamp circuit Refer to EXL-105, "DTC Logic" .	
Parking lamp, side marker lamp, tail lamp and license plate lamp are not turned ON.	Symptom diagnosis "PARKING, SIDE MARKER, LICENSE PLATE AND TAIL LAMPS ARE NOT TURNED ON" Refer to EXL-104, "DTC Logic" .		
Tail lamp indicator is not turned ON. (Exterior lamps are turned ON.)	Combination meter	<ul style="list-style-type: none"> • Combination meter "Data Monitor" "LIGHT IND" • BCM (HEADLAMP) "Active Test" "TAIL LAMP" 	
Turn signal lamp does not blink.	Indicator lamp is normal. (Applicable side performs high flasher activation.)	<ul style="list-style-type: none"> • Turn signal lamp bulb • Door mirror • Harness between BCM and each turn signal lamp • Harness between each turn signal lamp and ground Turn signal lamp circuit Refer to EXL-92, "Component Function Check" .	
Turn signal indicator lamp does not blink. (Turn signal lamp is normal.)	One side	Combination meter	—
	Both sides (Always)	<ul style="list-style-type: none"> • Turn signal indicator lamp signal • BCM • Combination meter 	<ul style="list-style-type: none"> • Combination meter "Data Monitor" "TURN IND" • BCM (FLASHER) "Active Test" "FLASHER"
	Both sides (Only when activating hazard warning lamp with ignition switch OFF)	<ul style="list-style-type: none"> • Combination meter power supply and ground circuit • Combination meter 	Combination meter Power supply and ground circuit Refer to MWI-60, "COMBINATION METER : Diagnosis Procedure" .
<ul style="list-style-type: none"> • Hazard warning lamp does not activate. • Hazard warning lamp continues activating. (Turn signal is normal.) 	<ul style="list-style-type: none"> • Hazard switch • Harness between hazard switch and BCM • Harness between hazard switch and ground • BCM 	Hazard switch circuit Refer to EXL-90, "Component Function Check" .	
Front fog lamp is not turned ON.	One side	<ul style="list-style-type: none"> • Front fog lamp bulb • Harness between IPDM E/R and front fog lamp • Harness between front fog lamp and ground • IPDM E/R 	Front fog lamp circuit Refer to EXL-96, "DTC Logic" (LH) or EXL-98, "DTC Logic" (RH).
	Both sides	Symptom diagnosis "BOTH SIDE FRONT FOG LAMPS ARE NOT TURNED ON" Refer to EXL-96, "DTC Logic" (LH) or EXL-98, "DTC Logic" (RH).	

NORMAL OPERATING CONDITION

< SYMPTOM DIAGNOSIS >

[HALOGEN HEADLAMP]

NORMAL OPERATING CONDITION

Description

INFOID:000000011280769

AUTO LIGHT SYSTEM

The headlamp may not be turned ON/OFF immediately after passing dark area or bright area (short tunnel, sky bridge, shadowed area, etc.) while using the auto light system. This is caused by the control difference. This is normal.

A

B

C

D

E

F

G

H

I

J

K

EXL

M

N

O

P

BOTH SIDE HEADLAMPS (HI) ARE NOT TURNED ON

< SYMPTOM DIAGNOSIS >

[HALOGEN HEADLAMP]

BOTH SIDE HEADLAMPS (HI) ARE NOT TURNED ON

Description

INFOID:000000011280770

Both side headlamps (HI) are not turned ON when setting to the lighting switch HI or PASS.

Diagnosis Procedure

INFOID:000000011280771

1.COMBINATION SWITCH INSPECTION

Check combination switch. Refer to [BCS-73, "Symptom Table"](#) (with Intelligent Key system) or [BCS-133, "Symptom Table"](#) (without Intelligent Key system).

Is the inspection result normal?

YES >> GO TO 2.

NO >> Repair or replace the malfunctioning part.

2.CHECK HEADLAMP (HI) REQUEST SIGNAL INPUT

④CONSULT DATA MONITOR

1. Select "HEADLAMP (HI)" in "Data Monitor" of "IPDM E/R".
2. With operating the lighting switch, check the monitor status.

Monitor item	Condition		Monitor status
HEADLAMP (HI)	Lighting switch (2ND)	HI or PASS	On
		LO	Off

Is the inspection result normal?

YES >> GO TO 3.

NO >> Replace BCM. Refer to [BCS-75, "Removal and Installation"](#) (with Intelligent Key system) or [BCS-135, "Removal and Installation"](#) (without Intelligent Key system).

3.HEADLAMP (HI) CIRCUIT INSPECTION

Check headlamp (HI) circuit. Refer to [EXL-100, "DTC Logic"](#) (LH) or [EXL-101, "DTC Logic"](#) (RH).

Is the inspection result normal?

YES >> Refer to [GI-44, "Intermittent Incident"](#).

NO >> Repair or replace the malfunctioning part.

BOTH SIDE HEADLAMPS (LO) ARE NOT TURNED ON

< SYMPTOM DIAGNOSIS >

[HALOGEN HEADLAMP]

BOTH SIDE HEADLAMPS (LO) ARE NOT TURNED ON

Description

INFOID:0000000011280772

Both side headlamps (LO) are not turned ON in any condition.

Diagnosis Procedure

INFOID:0000000011280773

1. CHECK COMBINATION SWITCH

Check combination switch. Refer to [BCS-73. "Symptom Table"](#) (with Intelligent Key system) or [BCS-133. "Symptom Table"](#) (without Intelligent Key system).

Is the inspection result normal?

YES >> GO TO 2.

NO >> Repair or replace the malfunctioning part.

2. CHECK HEADLAMP (LO) REQUEST SIGNAL INPUT

CONSULT DATA MONITOR

1. Select "HEADLAMP (LO)" in "Data Monitor" of "IPDM E/R".
2. With operating the lighting switch, check the monitor status.

Monitor item	Condition		Monitor status
HEADLAMP (LO)	Lighting switch	2ND	On
		OFF	Off

Is the inspection result normal?

YES >> GO TO 3.

NO >> Replace BCM. Refer to [BCS-75. "Removal and Installation"](#) (with Intelligent Key system) or [BCS-135. "Removal and Installation"](#) (without Intelligent Key system).

3. HEADLAMP (LO) CIRCUIT INSPECTION

Check headlamp (LO) circuit. Refer to [EXL-102. "DTC Logic"](#) (LH) or [EXL-103. "DTC Logic"](#) (RH).

Is the inspection result normal?

YES >> Refer to [GI-44. "Intermittent Incident"](#).

NO >> Repair or replace the malfunctioning part.

A
B
C
D
E
F
G
H
I
J
K
M
N
O
P

EXL

PARKING, LICENSE PLATE, SIDE MARKER AND TAIL LAMPS ARE NOT TURNED ON

< SYMPTOM DIAGNOSIS >

[HALOGEN HEADLAMP]

PARKING, LICENSE PLATE, SIDE MARKER AND TAIL LAMPS ARE NOT TURNED ON

Description

INFOID:000000011280774

The parking, license plate, side marker, tail lamps and each illumination are not turned ON in any condition.

Diagnosis Procedure

INFOID:000000011280775

1.COMBINATION SWITCH INSPECTION

Check combination switch. Refer to [BCS-73, "Symptom Table"](#) (with Intelligent Key system) or [BCS-133, "Symptom Table"](#) (without Intelligent Key system).

Is the combination switch normal?

YES >> GO TO 2.

NO >> Repair or replace the malfunctioning part.

2.CHECK TAIL LAMP REQUEST SIGNAL INPUT

CONSULT DATA MONITOR

1. Select "TAIL LAMP" in "Data Monitor" of "IPDM E/R".
2. With operating the lighting switch, check the monitor status.

Monitor item	Condition		Monitor status
TAIL LAMP	Lighting switch	1ST	On
		OFF	Off

Is the inspection result normal?

YES >> Replace IPDM E/R. Refer to [PCS-40, "Removal and Installation"](#).

NO >> Replace BCM. Refer to [BCS-75, "Removal and Installation"](#) (with Intelligent Key system) or [BCS-135, "Removal and Installation"](#) (without Intelligent Key system).

BOTH SIDE FRONT FOG LAMPS ARE NOT TURNED ON

< SYMPTOM DIAGNOSIS >

[HALOGEN HEADLAMP]

BOTH SIDE FRONT FOG LAMPS ARE NOT TURNED ON

Description

INFOID:000000011280776

The front fog lamps are not turned ON in any condition.

Diagnosis Procedure

INFOID:000000011280777

1. CHECK COMBINATION SWITCH

Check combination switch. Refer to [BCS-73, "Symptom Table"](#) (with Intelligent Key system) or [BCS-133, "Symptom Table"](#) (without Intelligent Key system).

Is the inspection result normal?

YES >> GO TO 3.

NO >> Repair or replace the malfunctioning part.

2. CHECK FRONT FOG LAMP REQUEST SIGNAL INPUT

CONSULT DATA MONITOR

1. Select "FRONT FOG LAMP REQ" in "Data Monitor" of "IPDM E/R".
2. With operating the front fog lamp switch, check the monitor status.

Monitor item	Condition		Monitor status
FRONT FOG LAMP REQ	Front fog lamp switch (With lighting switch 2ND)	ON	On
		OFF	Off

Is the item status normal?

YES >> Replace IPDM E/R. Refer to [PCS-40, "Removal and Installation"](#).

NO >> Replace BCM. Refer to [BCS-75, "Removal and Installation"](#) (with Intelligent Key system) or [BCS-135, "Removal and Installation"](#) (without Intelligent Key system).

A
B
C
D
E
F
G
H
I
J
K
M
N
O
P

EXL

HEADLAMP AIMING ADJUSTMENT

< PERIODIC MAINTENANCE >

[HALOGEN HEADLAMP]

PERIODIC MAINTENANCE

HEADLAMP AIMING ADJUSTMENT

Inspection

INFOID:000000011280778

PREPARATION BEFORE ADJUSTING

Before performing aiming adjustment, check the following:

- Make sure all tires are inflated to correct pressure.
- Place vehicle and screen on level surface.
- Make sure there is no load in vehicle other than the driver (or equivalent weight placed in driver's position).
- Coolant and engine oil filled to correct level, and fuel tank full.
- Remove cargo and/or luggage to maintain an unloaded vehicle condition.
- Confirm spare tire, jack and tools are properly stowed.
- Carefully wipe off any dirt from headlamp lens.

CAUTION:

Do not use organic solvent (thinner, gasoline etc.)

- Place a driver or equivalent weight of 68.5 kg (150 lb) on the driver seat.
- By hand, bounce the front and rear of the vehicle to settle the suspension and eliminate any static load.
- Place the front tires in the straight ahead position.
- Aim each headlamp individually and ensure other headlamp beam pattern is blocked from screen.

NOTE:

- For headlamp aiming details, refer to regulations in your area.
- By regulation, no means for horizontal aim adjustment is provided from the factory; only vertical aim is adjustable.
- Use adjusting screw to perform aiming adjustment.
- Perform headlamp aiming if:
 - The vehicle front body has been repaired;
 - The front combination lamp has been removed or replaced;
 - Any outfitting has been installed;
 - The vehicle's standard load condition has been substantially increased.

AIMING ADJUSTMENT SCREW

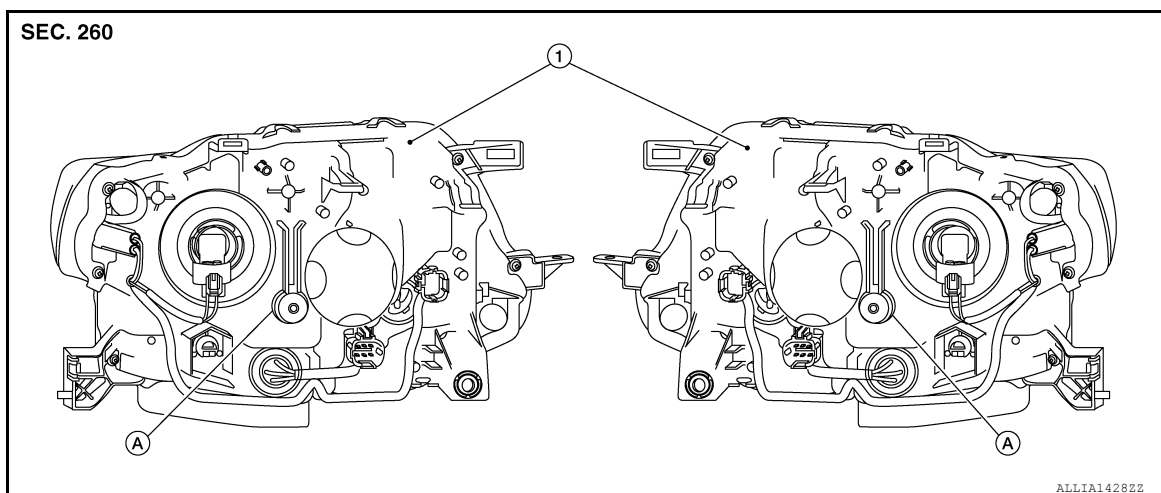

1. Front combination lamp
(view from rear)

A. Headlamp HI/LO (UP/DOWN)
adjustment screw

HEADLAMP AIMING ADJUSTMENT

< PERIODIC MAINTENANCE >

[HALOGEN HEADLAMP]

Aiming Adjustment Procedure

INFOID:000000011280779

Aiming Chart

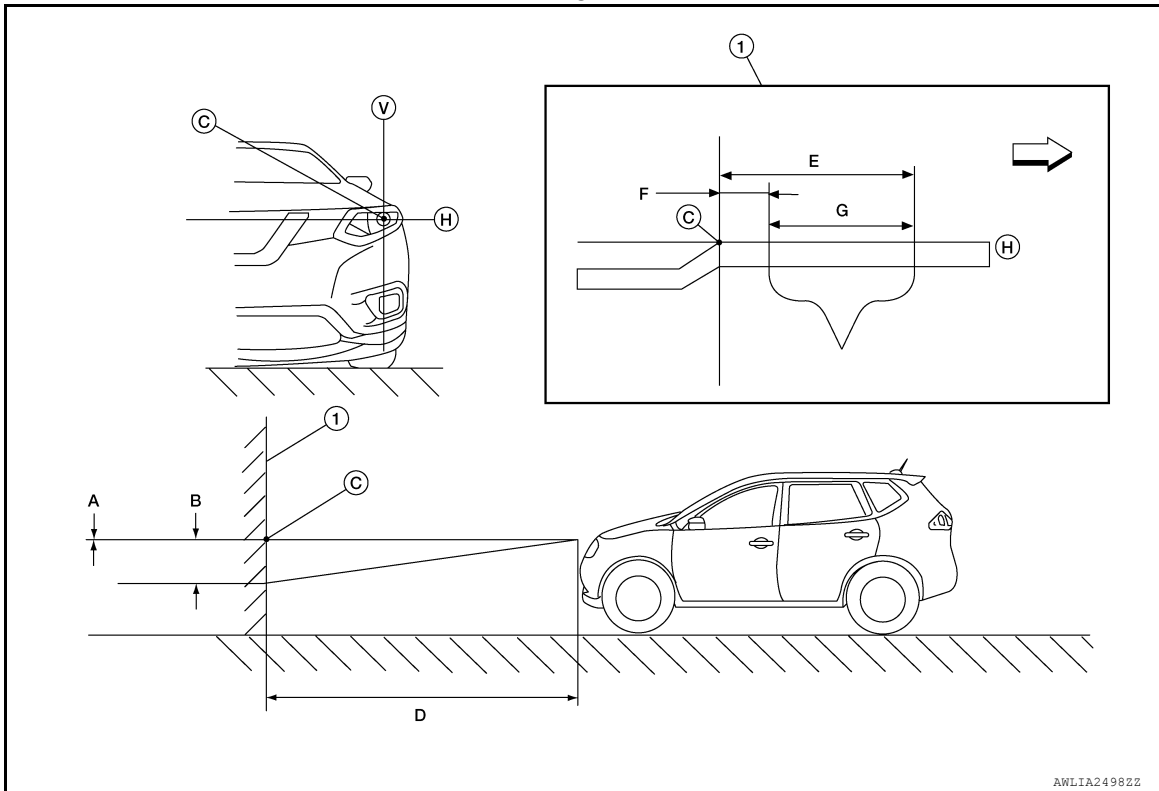

- | | | |
|---|---|---|
| 1. Adjustment screen | A. Highest cutoff line height | B. Lowest cutoff line height |
| C. Headlamp bulb center (H-V point) | D. Distance of headlamp aiming screen from vehicle 7.62 m (25 ft) | E. Maximum aim evaluation distance from vertical center on aiming screen 399 mm (3°R) |
| F. Minimum aim evaluation distance from vertical center on aiming screen 133 mm (1°R) | G. Aim evaluation area | H. Horizontal aiming evaluation line |
| V. Vertical aiming evaluation line | ↔ Right | |

A (Highest cutoff line height)	-13.3 mm (0.5 in)	0.1° up
B (Lowest cutoff line height)	53.2 mm (2.1 in)	0.4° down

LOW BEAM AND HIGH BEAM

NOTE:

- Basic illuminating area for evaluation and/or adjustment should be within range shown on aiming chart.

1. Use adjustment screw to perform aiming adjustment.
 - **Ensure fog lamps are turned off.**
2. Block the opposite headlamp from projecting a beam pattern onto the adjustment screen, using a suitable object. Aim each headlamp individually.

CAUTION:

Do not cover the lens surface with a tape etc. The lens is made of resin.

3. Place the screen on the same level and flat surface as the vehicle.

NOTE:

Surface should be free of any debris that would cause a difference between the headlamp center and the adjustment screen.

4. Face the front of the vehicle to the screen and measure distance between the headlamp center and the screen surface.

A
B
C
D
E
F
G
H
I
J
K

EXL

M
N
O
P

HEADLAMP AIMING ADJUSTMENT

< PERIODIC MAINTENANCE >

[HALOGEN HEADLAMP]

Distance between the headlamp center and the screen (D) : 7.62 m (25 ft)

5. Start the engine. Turn the headlamp on.
6. Determine the preferred vertical aim range dimensions, using the aiming chart.
7. Measure the projected beam within the aim evaluation segment on the screen.
8. Adjust the beam pattern of each headlamp until the aim evaluation segment (the area relative to both the highest and lowest cutoff line height) is positioned within the vertical aim range dimensions shown on the aiming chart.

FRONT FOG LAMP AIMING ADJUSTMENT

< PERIODIC MAINTENANCE >

[HALOGEN HEADLAMP]

FRONT FOG LAMP AIMING ADJUSTMENT

Aiming Adjustment Procedure

INFOID:000000011280780

Aiming Chart

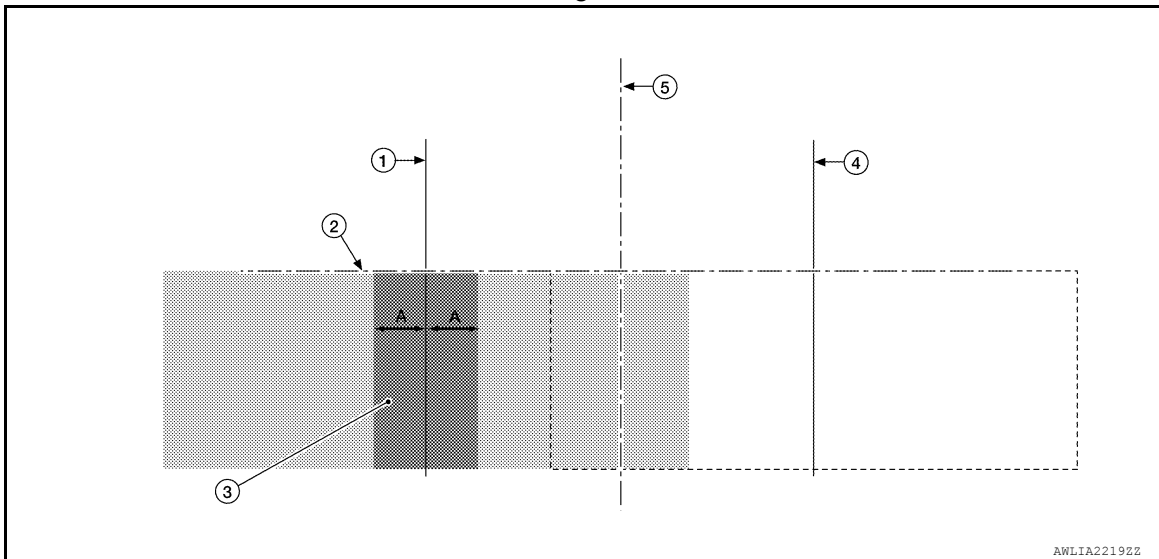

- | | | |
|--|-----------------------------|--|
| 1. Vertical center line of front fog lamp (LH) | 2. Lamp center above ground | 3. Front fog lamp high intensity area (LH) |
| 4. Vertical center line of front fog lamp (RH) | 5. Vertical center axis | A. 100mm (4in) |

NOTE:

- (LH) Front fog lamp aiming specifications shown, (RH) similar.
- Check the following conditions before performing the aiming adjustment.
 - Keep all tires inflated to correct pressure.
 - Place vehicle on level ground.
 - See that vehicle is unloaded (except for full levels of coolant, engine oil and fuel, and spare tire, jack, and tools). Have the driver or equivalent weight placed in driver seat.
 - When performing adjustment, if necessary, cover the headlamps and opposite front fog lamp.

1. Set the distance between the screen and the center of the front fog lamp lens as shown.

- (1) Aiming screen or a matte white surface
- (2) 7.62 m (25 ft)
- (3) Floor to center of front fog lamp lens
- (4) Floor

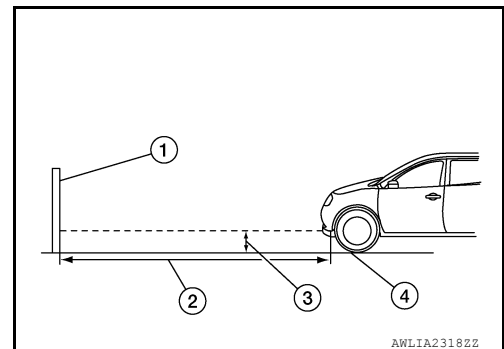

2. Turn front fog lamps ON.

FRONT FOG LAMP AIMING ADJUSTMENT

< PERIODIC MAINTENANCE >

[HALOGEN HEADLAMP]

3. Access adjusting screw (A) from underneath front bumper fascia. Adjust front fog lamps using adjusting screw so that the top edge of the high intensity zone is at the front fog lamp centers above ground.

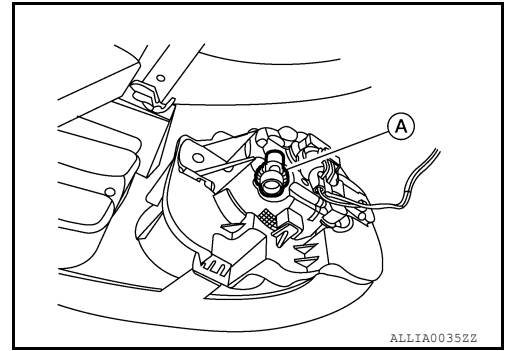

FRONT COMBINATION LAMP

< REMOVAL AND INSTALLATION >

[HALOGEN HEADLAMP]

REMOVAL AND INSTALLATION

FRONT COMBINATION LAMP

Exploded View

INFOID:000000011280781

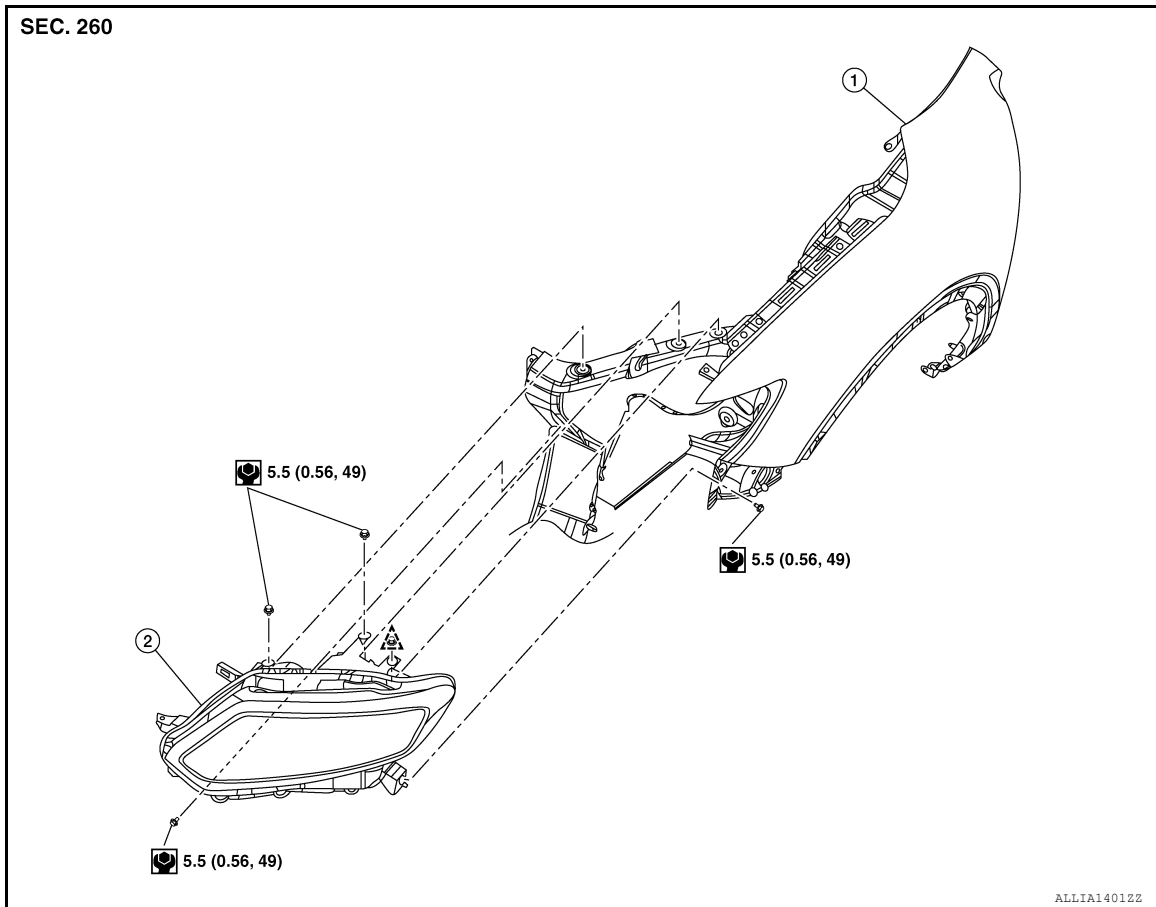

1. Front fender

2. Front combination lamp

Clip

Removal and Installation

INFOID:000000011280782

REMOVAL

1. Remove front bumper fascia. Refer to [EXT-17, "Removal and Installation"](#).
2. Remove front combination lamp bolts and clip.
3. Pull front combination lamp forward.
4. Disconnect the harness connectors from the front combination lamp and remove.

INSTALLATION

Installation is in the reverse order of removal.

NOTE:

After installation, perform headlamp aiming adjustment. Refer to [EXL-114, "Inspection"](#).

Bulb Replacement

INFOID:000000011280783

WARNING:

Do not touch bulb by hand while it is lit or right after being turned off. Burning may result.

CAUTION:

- Do not touch the glass surface of the bulb with bare hands or allow oil or grease to get on it to prevent damage to the bulb.

A
B
C
D
E
F
G
H
I
J
K

EXL

M
N
O
P

FRONT COMBINATION LAMP

< REMOVAL AND INSTALLATION >

[HALOGEN HEADLAMP]

- **Do not leave bulb out of lamp reflector for a long time because dust, moisture smoke, etc. may affect the performance of lamp. When replacing bulb, be sure to replace it with new one.**

HEADLAMP (LOW BEAM) BULB

Removal

1. Rotate the bulb counterclockwise and remove from the front combination lamp.
2. Disconnect the harness connector from bulb and remove.

Installation

Installation is in the reverse order of removal.

CAUTION:

After installing the bulb, install the bulb socket securely for watertightness.

HEADLAMP (HIGH BEAM) BULB

Removal

1. Remove plastic cover.
2. Rotate the bulb counterclockwise and remove from the front combination lamp.
3. Disconnect the harness connector from bulb and remove.

Installation

Installation is in the reverse order of removal.

CAUTION:

After installing the bulb, install the bulb socket securely for watertightness.

SIDE MARKER LAMP BULB

Removal

1. Rotate the bulb counterclockwise and remove from the front combination lamp.
2. Remove the bulb from the bulb socket.

Installation

Installation is in the reverse order of removal.

CAUTION:

After installing the bulb, install the bulb socket securely for watertightness.

TURN SIGNAL LAMP BULB

Removal

1. Rotate bulb socket counterclockwise and remove from the front combination lamp.
2. Remove the bulb from bulb socket.

Installation

Installation is in the reverse order of removal.

CAUTION:

After installing the bulb, install the bulb socket securely for watertightness.

FRONT FOG LAMP

< REMOVAL AND INSTALLATION >

[HALOGEN HEADLAMP]

FRONT FOG LAMP

Exploded View

INFOID:000000011280784

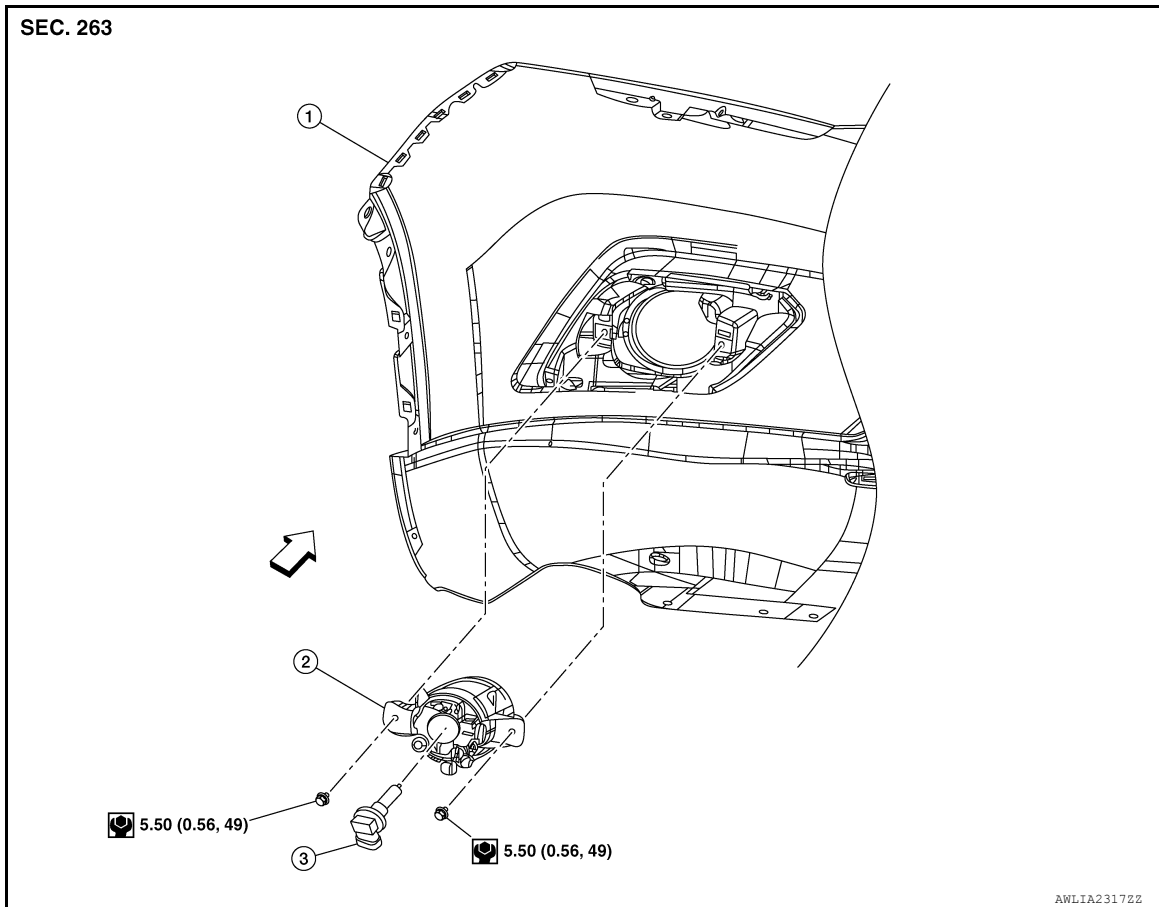

1. Front bumper fascia 2. Front fog lamp 3. Front fog lamp bulb
← Front

Removal and Installation

INFOID:000000011280785

EXL

REMOVAL

1. Partially remove front fender protector.
2. Disconnect the harness connector from the front fog lamp.
3. Remove front fog lamp bolts and front fog lamp.

INSTALLATION

Installation in the reverse order of removal.

NOTE:

After installation, perform front fog lamp aiming adjustment. Refer to [EXL-117. "Aiming Adjustment Procedure"](#).

Bulb Replacement

INFOID:000000011280786

WARNING:

Do not touch bulb by hand while it is lit or right after being turned off. Burning may result.

CAUTION:

- Do not touch the glass surface of the bulb with bare hands or allow oil or grease to get on it to prevent damage to the bulb.

FRONT FOG LAMP

[HALOGEN HEADLAMP]

< REMOVAL AND INSTALLATION >

- Do not leave bulb out of lamp reflector for a long time because dust, moisture smoke, etc. may affect the performance of lamp. When replacing bulb, be sure to replace it with new one.

REMOVAL

1. Partially remove front fender protector. Refer to [EXT-28. "FENDER PROTECTOR : Exploded View"](#).
2. Disconnect the harness connector (A) from the front fog lamp.
3. Rotate bulb (1) counterclockwise and remove.

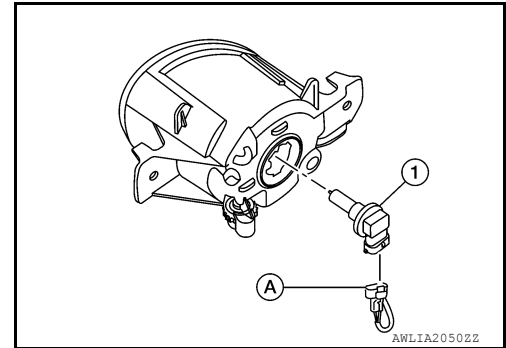

INSTALLATION

Installation is in the reverse order of removal.

CAUTION:

After installing the bulb, install the bulb socket securely for watertightness.

OPTICAL SENSOR

< REMOVAL AND INSTALLATION >

[HALOGEN HEADLAMP]

OPTICAL SENSOR

Exploded View

INFOID:000000011343028

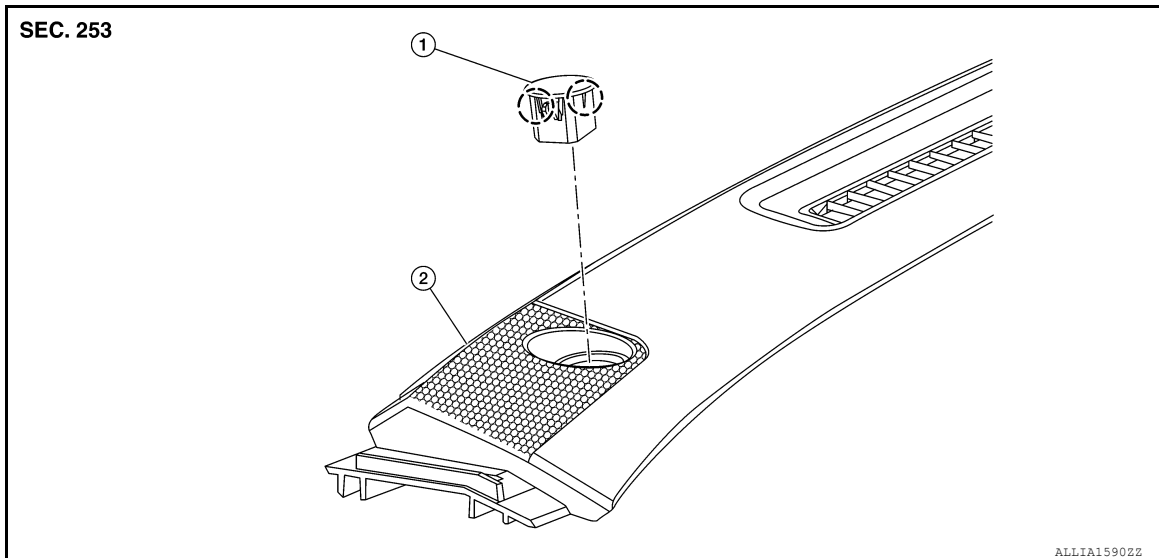

1. Optical sensor

2. Defroster grille

○ Pawl

Removal and Installation

INFOID:000000011280787

REMOVAL

1. Release the optical sensor (2) pawls from defroster grille (1) using a suitable tool.

○: Pawl

2. Disconnect the harness connector (A) from the optical sensor (2) and remove.

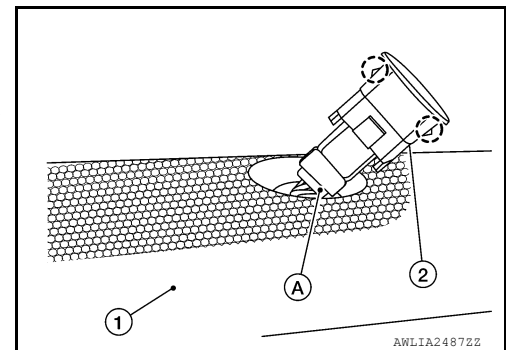

INSTALLATION

Installation is in the reverse order of removal.

A
B
C
D
E
F
G
H
I
J
K
EXL
M
N
O
P

COMBINATION SWITCH

< REMOVAL AND INSTALLATION >

[HALOGEN HEADLAMP]

COMBINATION SWITCH

Exploded View

INFOID:000000011280788

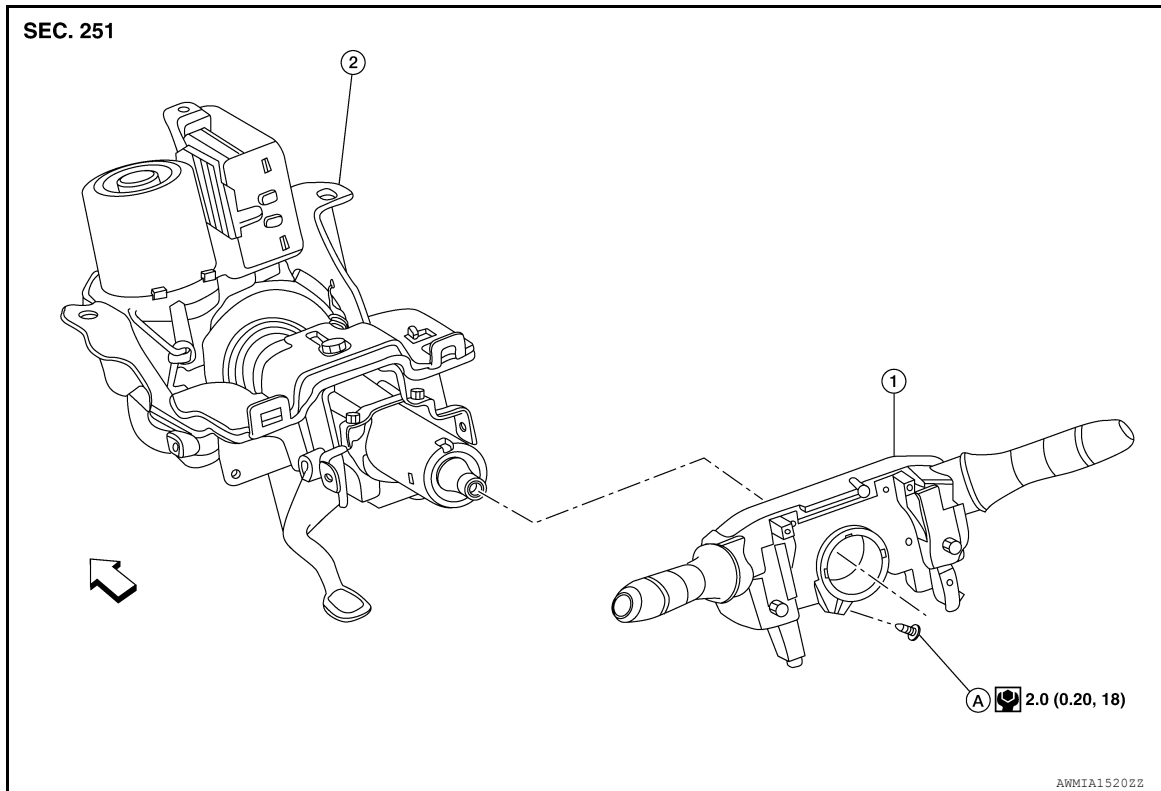

1. Combination switch

2. Steering column

A. Screw

⇐ Front

Removal and Installation

INFOID:000000011280789

REMOVAL

1. Remove the steering angle sensor. Refer to [BRC-137, "Removal and Installation"](#).
2. Disconnect harness connector from combination switch.
3. Remove screw (A) and combination switch (1).

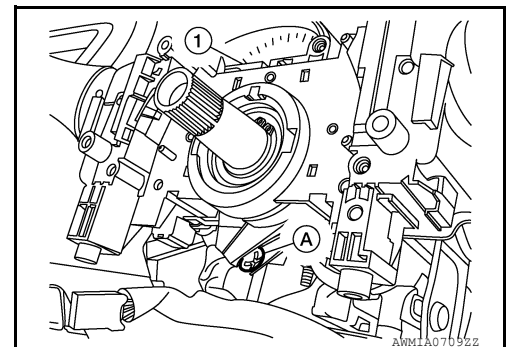

INSTALLATION

Installation is in the reverse order of removal.

HAZARD SWITCH

< REMOVAL AND INSTALLATION >

[HALOGEN HEADLAMP]

HAZARD SWITCH

Exploded View

INFOID:000000011280790

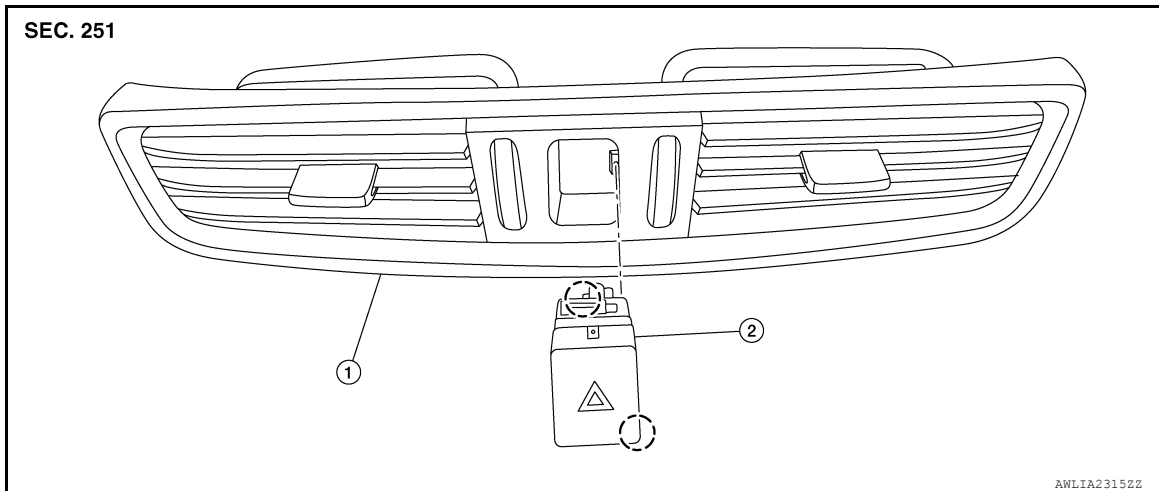

1. Center ventilator grille

2. Hazard switch

3. Pawl

Removal and Installation

INFOID:000000011280791

REMOVAL

1. Remove center ventilator grille. Refer to [VTL-13. "CENTER VENTILATOR GRILLE : Removal and Installation"](#).
2. Release the pawls and remove the hazard switch.

INSTALLATION

Installation is in the reverse order of removal.

A
B
C
D
E
F
G
H
I
J
K
L
M
N
O
P

EXL

SIDE TURN SIGNAL LAMP

< REMOVAL AND INSTALLATION >

[HALOGEN HEADLAMP]

SIDE TURN SIGNAL LAMP

Removal and Installation

INFOID:000000011280792

REMOVAL

1. Remove door mirror rear finisher. Refer to [MIR-26, "Removal and Installation"](#).
2. Remove door mirror glass. Refer to [MIR-24, "Removal and Installation"](#).
3. Remove the screws (A) and reposition side turn signal lamp.

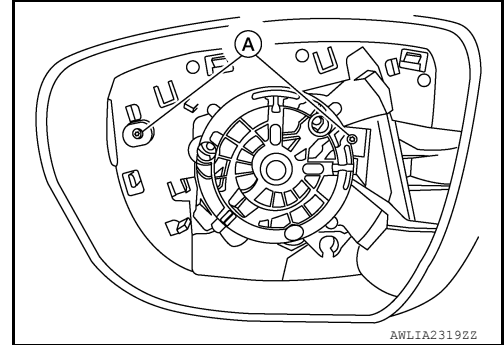

4. Disconnect the harness connector from the side turn signal lamp and remove.

INSTALLATION

Installation is in the reverse order of removal.

Bulb Replacement

INFOID:000000011280793

The side turn signal lamp bulb is not serviced separately. Refer to [EXL-126, "Removal and Installation"](#).

REAR COMBINATION LAMP

< REMOVAL AND INSTALLATION >

[HALOGEN HEADLAMP]

REAR COMBINATION LAMP

Exploded View

INFOID:000000011280794

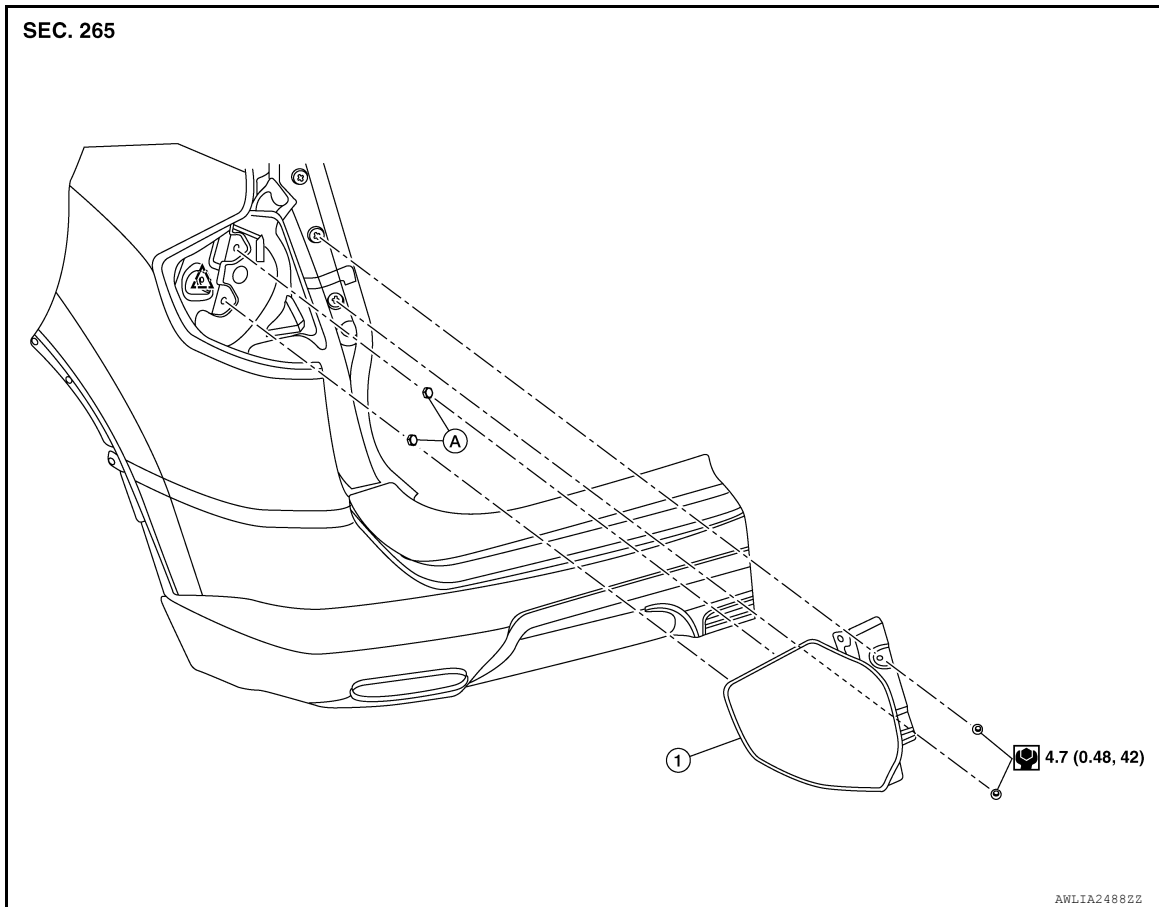

1. Rear combination lamp

A. Grommet

 Clip

Removal and Installation

INFOID:000000011280795

REMOVAL

1. Remove side air spoiler. Refer to [EXT-49. "Removal and Installation"](#).
2. Remove rear combination lamp bolts.
3. Pull rear combination lamp rearward to release from clip and locators.
4. Disconnect the harness connector from the rear combination lamp and remove.

INSTALLATION

Installation is in the reverse order of removal.

Bulb Replacement

INFOID:000000011280796

WARNING:

Do not touch bulb with bare hand while it is lit or right after being turned off. Burning may result.

CAUTION:

- Do not touch the glass surface of the bulb with bare hands or allow oil or grease to get on it to prevent damage to the bulb.
- Do not leave bulb out of lamp reflector for a long time because dust, moisture smoke, etc. may affect the performance of lamp. When replacing bulb, be sure to replace it with new one.

STOP LAMP BULB

REAR COMBINATION LAMP

[HALOGEN HEADLAMP]

< REMOVAL AND INSTALLATION >

Removal

1. Remove rear combination lamp. Refer to [EXL-127. "Removal and Installation"](#).
2. Rotate stop lamp bulb socket counterclockwise and remove.
3. Remove stop lamp bulb from bulb socket.

Installation

Installation is in the reverse order of removal.

CAUTION:

After installing the bulb, install bulb socket securely for watertightness.

TAIL LAMP BULB

Removal

1. Remove rear combination lamp. Refer to [EXL-127. "Removal and Installation"](#).
2. Rotate tail lamp bulb socket counterclockwise and remove.
3. Remove tail lamp bulb from bulb socket.

Installation

Installation is in the reverse order of removal.

CAUTION:

After installing the bulb, install bulb socket securely for watertightness.

TURN SIGNAL LAMP BULB

Removal

1. Remove rear combination lamp. Refer to [EXL-127. "Removal and Installation"](#).
2. Rotate turn signal lamp bulb socket counterclockwise and remove.
3. Remove turn signal lamp bulb from bulb socket.

Installation

Installation is in the reverse order of removal.

CAUTION:

After installing the bulb, install bulb socket securely for watertightness.

HIGH-MOUNTED STOP LAMP

< REMOVAL AND INSTALLATION >

[HALOGEN HEADLAMP]

HIGH-MOUNTED STOP LAMP

Exploded View

INFOID:000000011280797

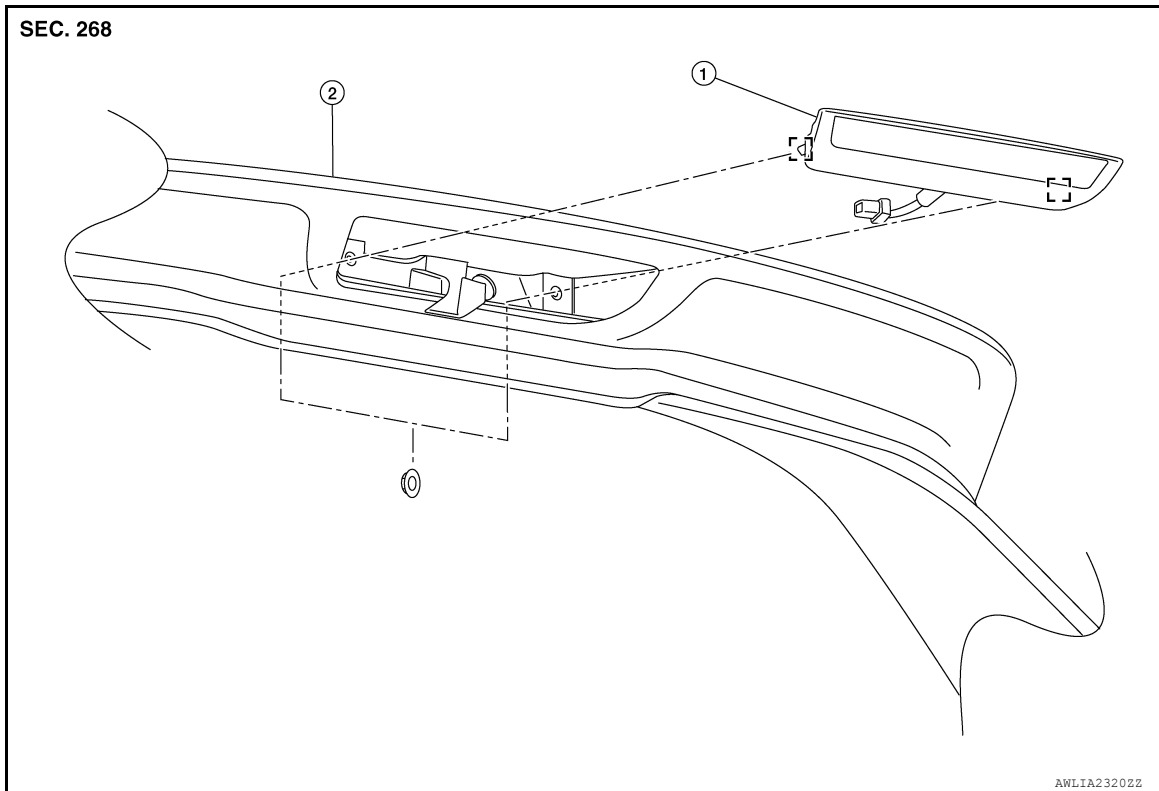

1. High-mounted stop lamp

2. Back door

3. Stud

Removal and Installation

INFOID:000000011280798

REMOVAL

1. Remove access cover using a suitable tool. Refer to [INT-38, "Exploded View"](#).
2. Remove high-mounted stop lamp nuts.
3. Disconnect the harness connector from high-mounted stop lamp and remove.

INSTALLATION

Installation is in the reverse order of removal.

Bulb Replacement

INFOID:000000011280799

HIGH-MOUNTED STOP LAMP BULB

The high-mounted stop lamp bulb is not serviced separately. Refer to [EXL-129, "Removal and Installation"](#).

BACK-UP LAMP ASSEMBLY

< REMOVAL AND INSTALLATION >

[HALOGEN HEADLAMP]

BACK-UP LAMP ASSEMBLY

Exploded View

INFOID:000000011280800

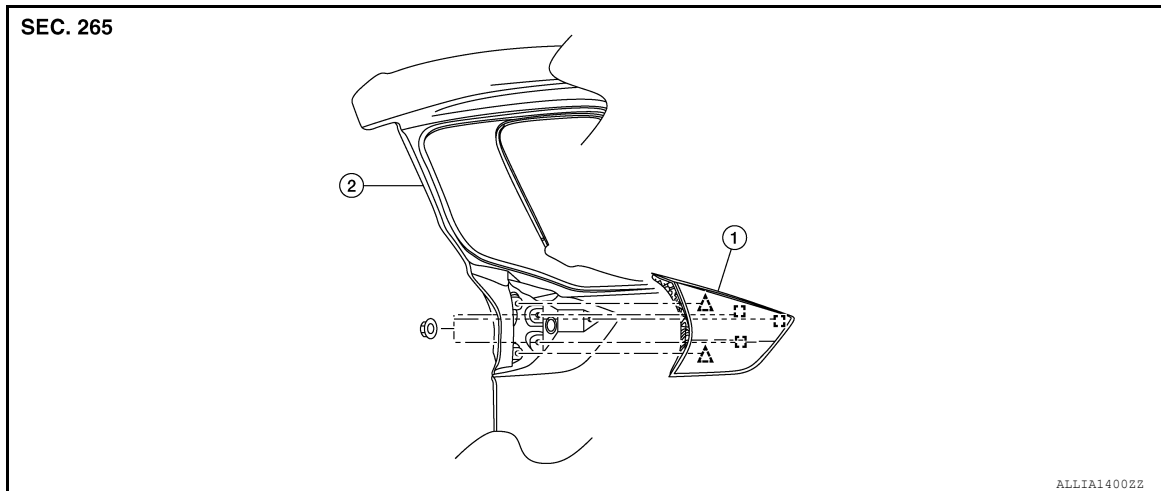

1. Back-up lamp assembly

2. Back door

△ Clip

□ Stud

Removal and Installation

INFOID:000000011280801

REMOVAL

1. Remove back door finisher. Refer to [INT-38. "Removal and Installation"](#).
2. Remove back-up lamp assembly nuts.
3. Pull back-up lamp assembly rearward, disconnect the harness connector and remove.

INSTALLATION

Installation is in the reverse order of removal.

Bulb Replacement

INFOID:000000011280802

WARNING:

Do not touch bulb with bare hand while it is lit or right after being turned off. Burning may result.

CAUTION:

- Do not touch the glass surface of the bulb with bare hands or allow oil or grease to get on it to prevent damage to the bulb.
- Do not leave bulb out of lamp reflector for a long time because dust, moisture smoke, etc. may affect the performance of lamp. When replacing bulb, be sure to replace it with new one.

TAIL LAMP BULB

Removal

1. Remove back-up lamp assembly. Refer to [EXL-130. "Removal and Installation"](#).
2. Rotate tail lamp bulb socket counterclockwise and remove.
3. Remove tail lamp bulb from bulb socket.

Installation

Installation is in the reverse order of removal.

CAUTION:

After installing the bulb, install bulb socket securely for watertightness.

BACK-UP LAMP BULB

Removal

BACK-UP LAMP ASSEMBLY

[HALOGEN HEADLAMP]

< REMOVAL AND INSTALLATION >

1. Remove back-up lamp assembly. Refer to [EXL-130. "Removal and Installation"](#).
2. Rotate back-up lamp bulb socket counterclockwise and remove.
3. Remove back-up lamp bulb from bulb socket.

Installation

Installation is in the reverse order of removal.

CAUTION:

After installing the bulb, install bulb socket securely for watertightness.

A

B

C

D

E

F

G

H

I

J

K

EXL

M

N

O

P

LICENSE PLATE LAMP

< REMOVAL AND INSTALLATION >

[HALOGEN HEADLAMP]

LICENSE PLATE LAMP

Exploded View

INFOID:000000011280803

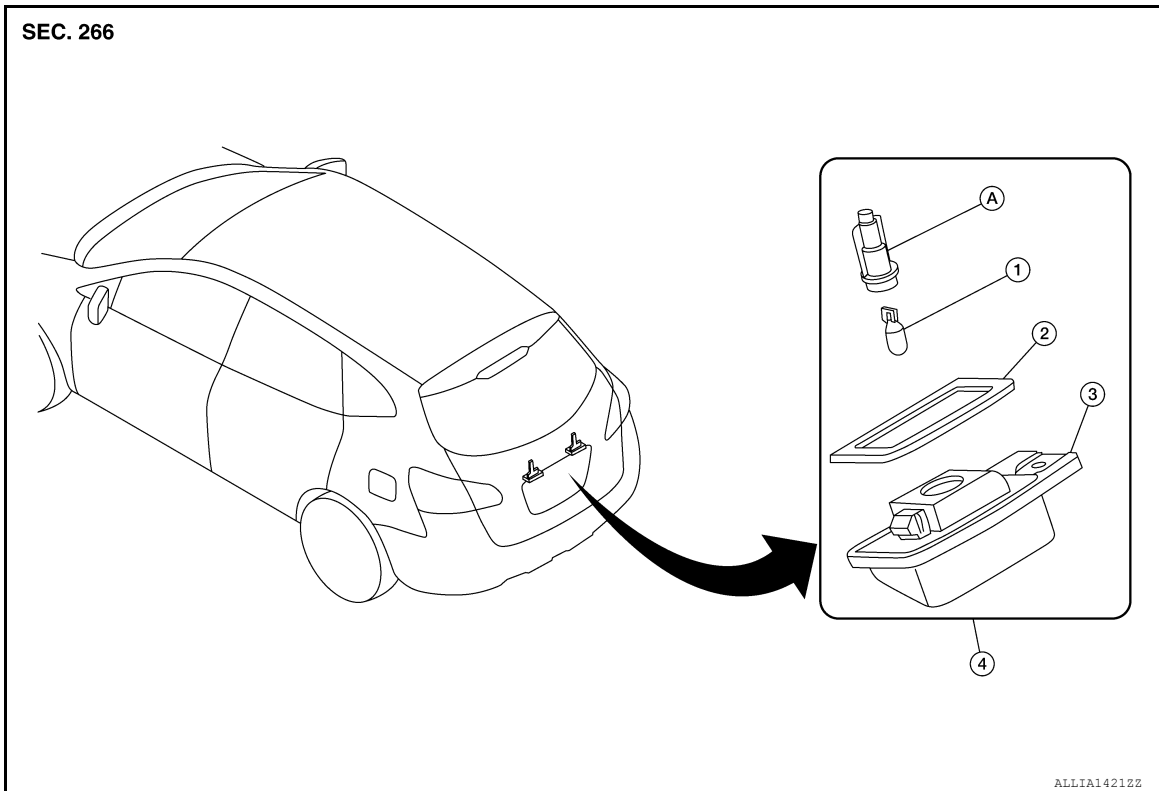

- | | | |
|--------------------------------|-----------------------------------|-----------------------|
| 1. License plate lamp bulb | 2. License plate lamp seal | 3. License plate lamp |
| 4. License plate lamp assembly | A. License plate lamp bulb socket | |

Removal and Installation

INFOID:000000011280804

REMOVAL

1. Release the license lamp finisher. Refer to [EXT-51. "Exploded View"](#).
2. Remove the screw (A) (LH or RH) and pull license plate lamp (1) (LH or RH) downward.

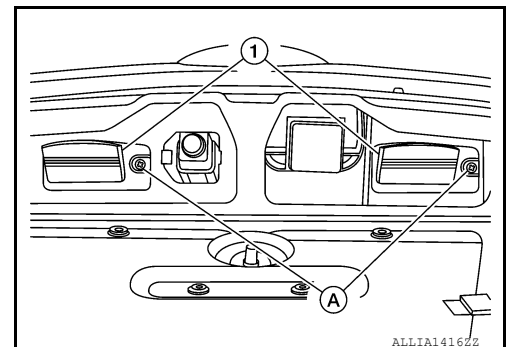

3. Disconnect the harness connector from the license plate lamp and remove.

INSTALLATION

Installation is in the reverse order of removal.

Bulb Replacement

INFOID:000000011280805

WARNING:

Do not touch bulb with your hand while it is on or right after being turned off. Burning may result.

LICENSE PLATE LAMP

< REMOVAL AND INSTALLATION >

[HALOGEN HEADLAMP]

CAUTION:

- Do not touch the glass surface of the bulb with bare hands or allow oil or grease to get on it to prevent damage to the bulb.
- Do not leave bulb out of lamp reflector for a long time because dust, moisture smoke, etc. may affect the performance of lamp. When replacing bulb, be sure to replace it with new one.

REMOVAL

1. Remove license plate lamp. Refer to [EXL-132. "Removal and Installation"](#).
2. Rotate license plate lamp bulb socket counterclockwise and remove.
3. Remove license plate lamp bulb from bulb socket.

INSTALLATION

Installation is in the reverse order of removal.

CAUTION:

After installing the bulb, install the bulb socket securely for watertightness.

A
B
C
D
E
F
G
H
I
J
K
L
M
N
O
P

EXL

FRONT COMBINATION LAMP

< UNIT DISASSEMBLY AND ASSEMBLY >

[HALOGEN HEADLAMP]

UNIT DISASSEMBLY AND ASSEMBLY

FRONT COMBINATION LAMP

Exploded View

INFOID:000000011280806

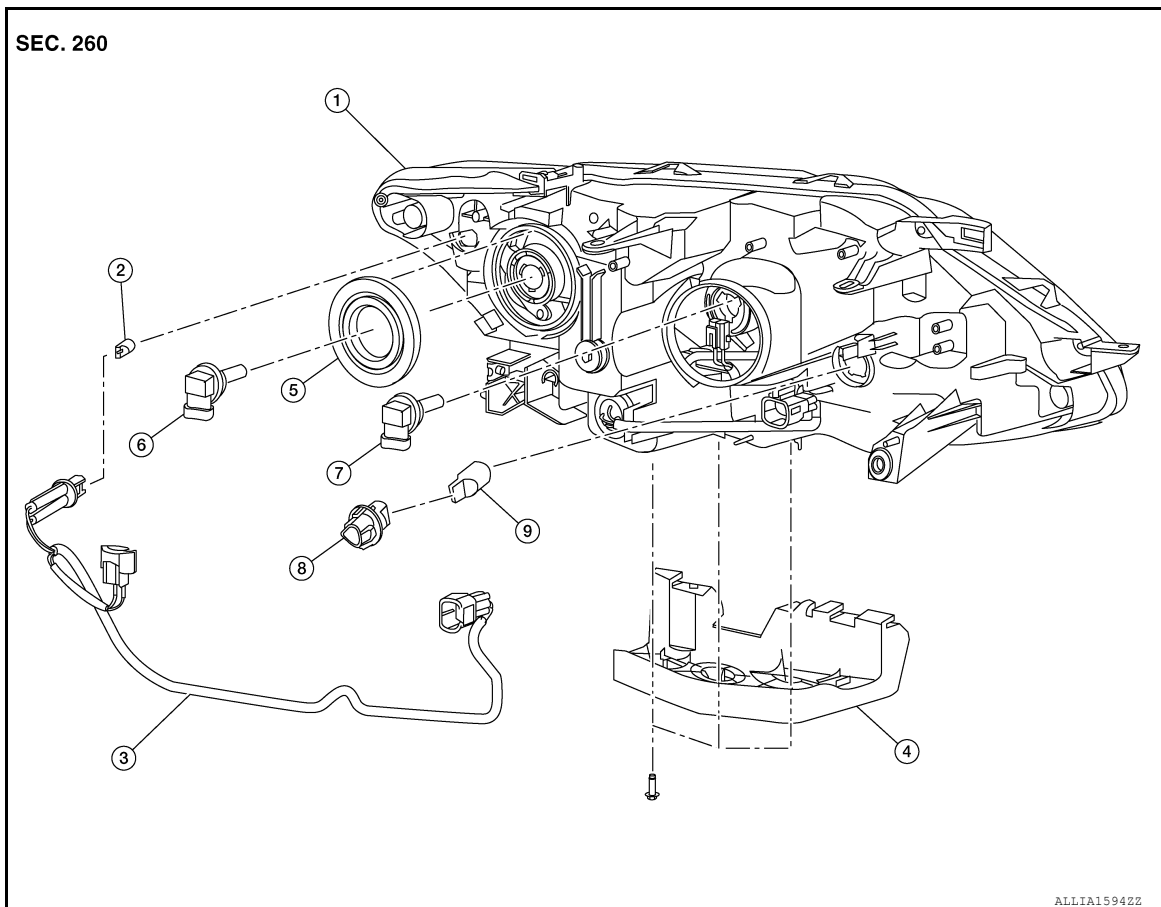

- | | | |
|--|-------------------------------------|-----------------------------------|
| 1. Front combination lamp | 2. Side marker lamp bulb | 3. Front combination lamp harness |
| 4. Front combination lamp mounting bracket | 5. Headlamp (low beam) socket cover | 6. Headlamp (low beam) bulb |
| 7. Headlamp (high beam) bulb | 8. Turn signal lamp bulb socket | 9. Turn signal lamp bulb |

Disassembly and Assembly

INFOID:000000011280807

DISASSEMBLY

1. Remove front combination lamp. Refer to [EXL-119. "Removal and Installation"](#).
2. Rotate the headlamp (low beam) bulb counterclockwise and remove.
3. Disconnect the harness connector from headlamp (low beam) bulb.
4. Remove plastic cover.
5. Rotate the headlamp (high beam) bulb counterclockwise and remove.
6. Disconnect the harness connector from headlamp (high beam) bulb.
7. Rotate the side marker lamp bulb socket counterclockwise and remove.
8. Remove the side marker lamp bulb from the bulb socket.
9. Rotate the turn signal lamp bulb socket counterclockwise and remove.
10. Remove the turn signal lamp bulb from the bulb socket.

ASSEMBLY

Assembly is in the reverse order of disassembly.

CAUTION:

After installing, be sure to install the bulb sockets securely to ensure watertightness.

REAR COMBINATION LAMP

< UNIT DISASSEMBLY AND ASSEMBLY >

[HALOGEN HEADLAMP]

REAR COMBINATION LAMP

Exploded View

INFOID:000000011280808

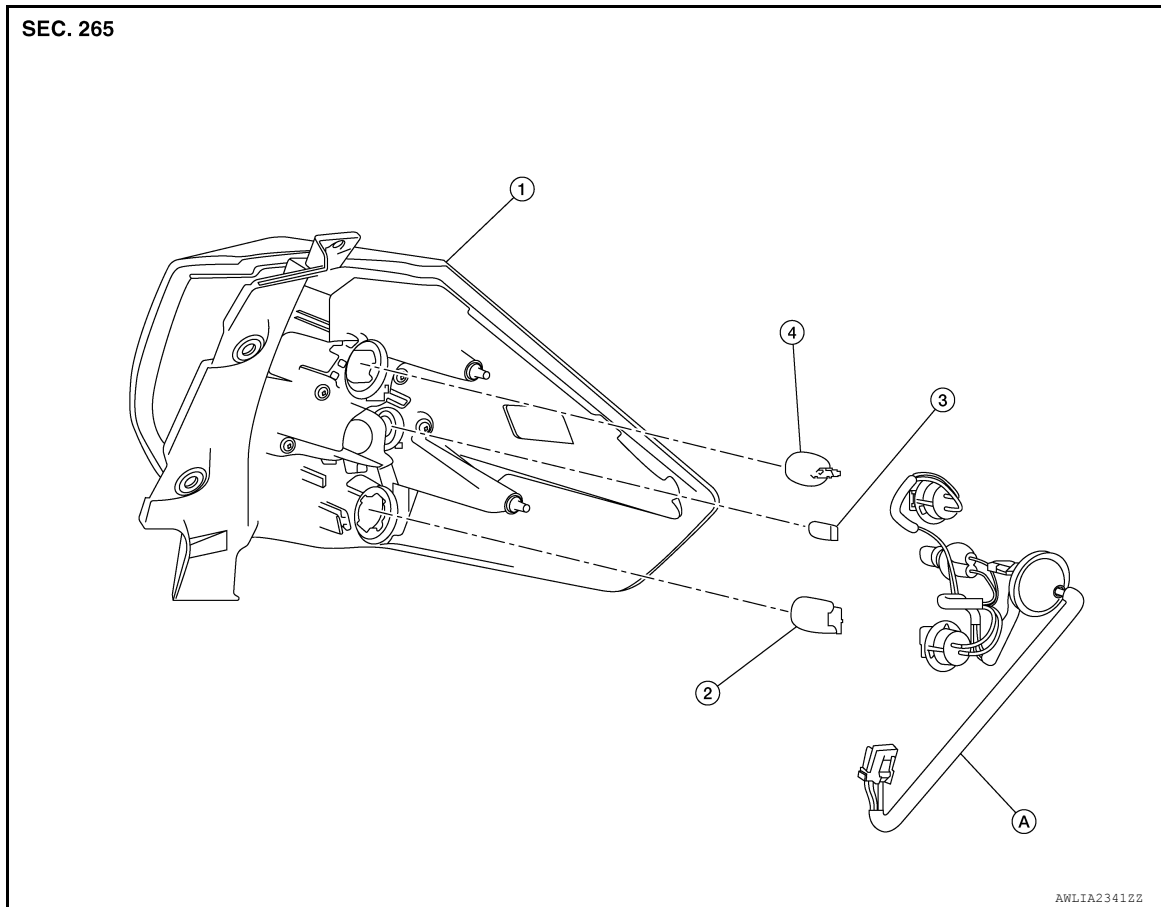

- | | | |
|--------------------------|----------------------------------|-------------------|
| 1. Rear combination lamp | 2. Turn signal lamp bulb | 3. Tail lamp bulb |
| 4. Stop lamp bulb | A. Rear combination lamp harness | |

Disassembly and Assembly

INFOID:000000011280809

DISASSEMBLY

1. Remove rear combination lamp. Refer to [EXL-127, "Removal and Installation"](#).
2. Rotate the stop lamp bulb socket counterclockwise and remove.
3. Remove the stop lamp bulb from the bulb socket.
4. Rotate the tail lamp bulb socket counterclockwise and remove.
5. Remove the tail lamp bulb from the bulb socket.
6. Rotate the turn signal lamp bulb socket counterclockwise and remove.
7. Remove the turn signal lamp bulb from bulb socket.

ASSEMBLY

Assembly is in the reverse order of disassembly.

CAUTION:

After installing, be sure to install the bulb sockets securely to ensure watertightness.

SERVICE DATA AND SPECIFICATIONS (SDS)

< SERVICE DATA AND SPECIFICATIONS (SDS)

[HALOGEN HEADLAMP]

SERVICE DATA AND SPECIFICATIONS (SDS)

SERVICE DATA AND SPECIFICATIONS (SDS)

Bulb Specifications

INFOID:000000011280810

	Item	Wattage (W)*
Front combination lamp	High beam	65
	Low beam	55
	Turn signal lamp	28/8
	Side marker lamp	5
	Daytime running lamp	—
Front fog lamp (if equipped)		55
Side turn signal lamp		—
Rear combination lamp	Stop lamp	21
	Tail lamp	5
	Turn signal lamp	21
Back-up lamp	Tail lamp	5
	Back-up lamp	16
License plate lamp		5
High-mounted stop lamp		—

*: Always check with the Parts Department for the latest parts info.

PRECAUTION

PRECAUTIONS

Precaution for Supplemental Restraint System (SRS) "AIR BAG" and "SEAT BELT PRE-TENSIONER"

INFOID:000000011280811

The Supplemental Restraint System such as "AIR BAG" and "SEAT BELT PRE-TENSIONER", used along with a front seat belt, helps to reduce the risk or severity of injury to the driver and front passenger for certain types of collision. Information necessary to service the system safely is included in the SR and SB section of this Service Manual.

WARNING:

- To avoid rendering the SRS inoperative, which could increase the risk of personal injury or death in the event of a collision which would result in air bag inflation, all maintenance must be performed by an authorized NISSAN/INFINITI dealer.
- Improper maintenance, including incorrect removal and installation of the SRS, can lead to personal injury caused by unintentional activation of the system. For removal of Spiral Cable and Air Bag Module, see the SR section.
- Do not use electrical test equipment on any circuit related to the SRS unless instructed to in this Service Manual. SRS wiring harnesses can be identified by yellow and/or orange harnesses or harness connectors.

PRECAUTIONS WHEN USING POWER TOOLS (AIR OR ELECTRIC) AND HAMMERS

WARNING:

- When working near the Airbag Diagnosis Sensor Unit or other Airbag System sensors with the Ignition ON or engine running, DO NOT use air or electric power tools or strike near the sensor(s) with a hammer. Heavy vibration could activate the sensor(s) and deploy the air bag(s), possibly causing serious injury.
- When using air or electric power tools or hammers, always switch the Ignition OFF, disconnect the battery and wait at least three minutes before performing any service.

Precaution for Work

INFOID:000000011280812

- When removing or disassembling each component, be careful not to damage or deform it. If a component may be subject to interference, be sure to protect it with a shop cloth.
- When removing (disengaging) components with a screwdriver or similar tool, be sure to wrap the component with a shop cloth or vinyl tape to protect it.
- Protect the removed parts with a shop cloth and prevent them from being dropped.
- Replace a deformed or damaged clip.
- If a part is specified as a non-reusable part, always replace it with a new one.
- Be sure to tighten bolts and nuts securely to the specified torque.
- After installation is complete, be sure to check that each part works properly.
- Follow the steps below to clean components:
 - Water soluble dirt:
 - Dip a soft cloth into lukewarm water, wring the water out of the cloth and wipe the dirty area.
 - Then rub with a soft, dry cloth.
 - Oily dirt:
 - Dip a soft cloth into lukewarm water with mild detergent (concentration: within 2 to 3%) and wipe the dirty area.
 - Then dip a cloth into fresh water, wring the water out of the cloth and wipe the detergent off.
 - Then rub with a soft, dry cloth.
 - Do not use organic solvent such as thinner, benzene, alcohol or gasoline.
 - For genuine leather seats, use a genuine leather seat cleaner.

A
B
C
D
E
F
G
H
I
J
K
M
N
O
P

EXL

PREPARATION

PREPARATION

Special Service Tool

INFOID:000000011280813

The actual shape of the tools may differ from those illustrated here.

Tool number (TechMate No.) Tool name	Description
— (J-46534) Trim Tool Set	Removing trim components

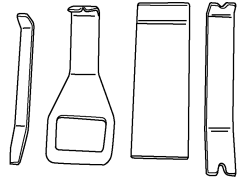

AWJIA0483ZZ

COMPONENT PARTS

< SYSTEM DESCRIPTION >

[LED HEADLAMP]

SYSTEM DESCRIPTION

COMPONENT PARTS

Component Parts Location

INFOID:0000000011280814

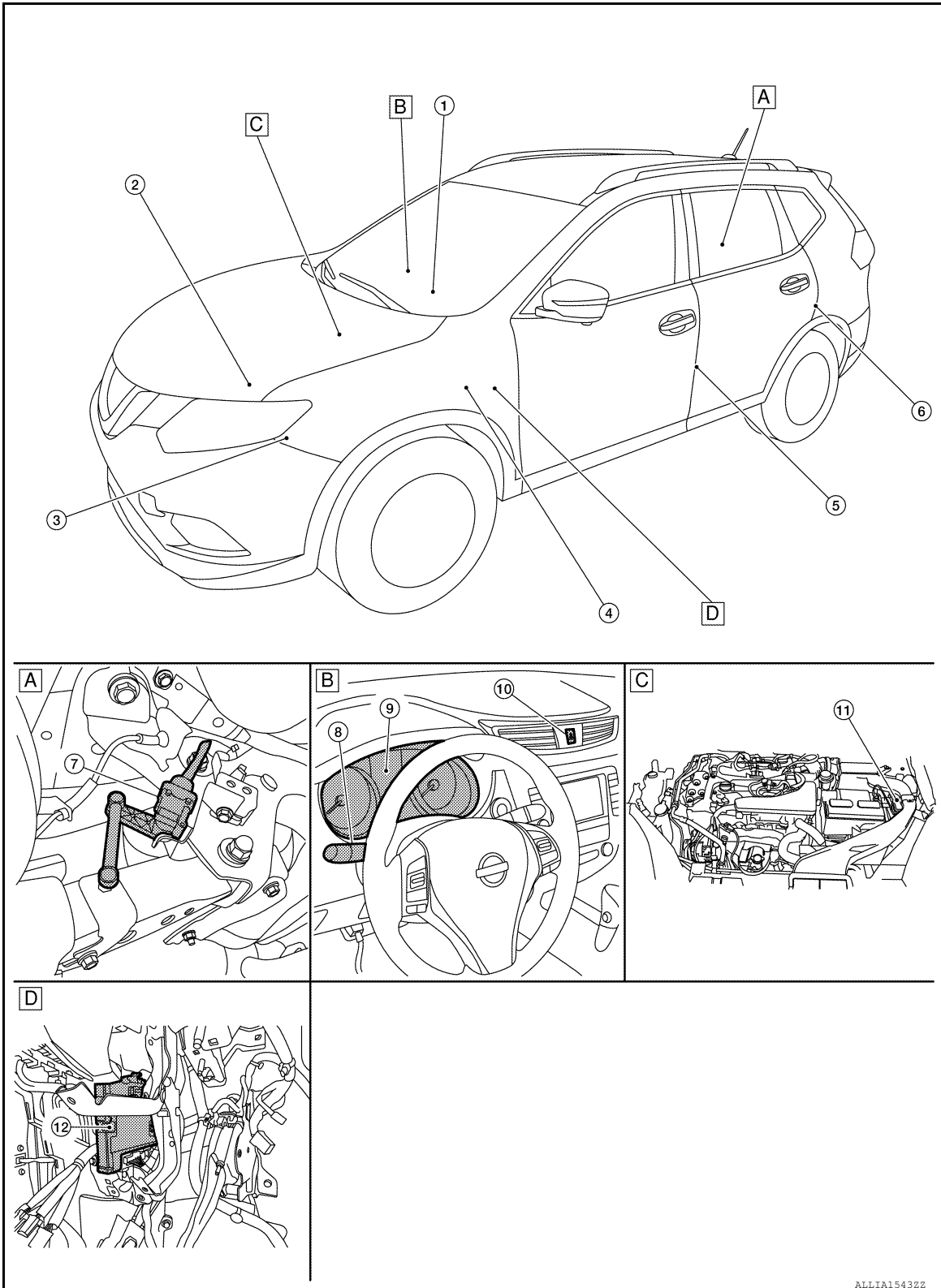

A
B
C
D
E
F
G
H
I
J
K
EXL
M
N
O
P

COMPONENT PARTS

[LED HEADLAMP]

< SYSTEM DESCRIPTION >

- A. Right rear wheel area B. Instrument panel C. Engine compartment
 D. Left side of instrument panel (view with trim panel removed)

No.	Part	Function
1.	Optical sensor	Refer to EXL-10, "Optical Sensor" .
2.	LED headlamp control module	Turns the headlamps ON according to the power supply from IPDM E/R.
3.	Headlamp aiming motor	Moves the headlamps up/down based on inputs from the rear height sensor.
4.	Parking brake switch	Transmits the parking brake switch signal to the combination meter to operate the daytime running light system.
5.	Front door switch LH (RH similar)	Transmits the door open signal to the BCM to operate the autolight system.
6.	Rear door switch LH (RH similar)	
7.	Rear height sensor	Sends the vehicles pitch angle signal to the IPDM E/R necessary for adjusting the headlamp aiming motors.
8.	Combination switch (Lighting and turn signal switch)	Refer to BCS-9, "COMBINATION SWITCH READING SYSTEM : System Description" (with Intelligent Key system) or BCS-81, "COMBINATION SWITCH READING SYSTEM : System Description" (without Intelligent Key system).
9.	Combination meter	Refer to MWI-8, "METER SYSTEM : System Description" .
10.	Hazard switch	Refer to EXL-11, "Hazard Switch" .
11.	IPDM E/R	<ul style="list-style-type: none"> Supplies voltage to the load according to the request from BCM (via CAN communication). Refer to PCS-6, "Component Parts Location" for detailed installation location.
12.	BCM	<ul style="list-style-type: none"> Detects each switch condition by the combination switch reading function. Judges that the exterior lamps are turned ON according to the vehicle condition. Requests the headlamp (HI/LO), tail lamp and front fog lamp ON to IPDM E/R (via CAN communication). Requests high beam indicator lamp ON to the combination meter (via CAN communication). Judges the outside brightness from the optical sensor signal. Judges the ON/OFF timing according to the vehicle condition. Judges the ON/OFF status of the exterior lamp according to the outside brightness and the vehicle condition. Refer to BCS-7, "BODY CONTROL SYSTEM : Component Parts Location" (with Intelligent Key system) or BCS-79, "BODY CONTROL SYSTEM : Component Parts Location" (without Intelligent Key system).

Optical Sensor

INFOID:000000011280815

Optical sensor converts the outside brightness (lux) to voltage and transmits the optical sensor signal to BCM.

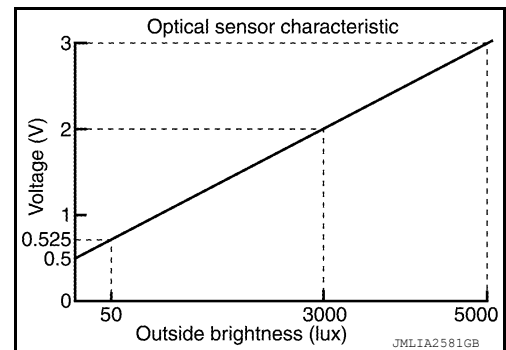

COMPONENT PARTS

< SYSTEM DESCRIPTION >

[LED HEADLAMP]

Hazard Switch

INFOID:000000011280816

Inputs the hazard switch ON/OFF signal to BCM.

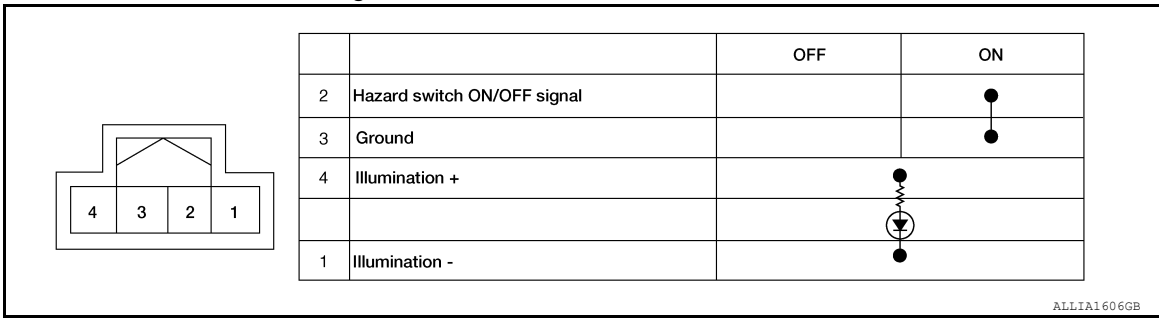

A
B
C
D
E
F
G
H
I
J
K
EXL
M
N
O
P

SYSTEM

HEADLAMP SYSTEM

HEADLAMP SYSTEM : System Description

INFOID:000000011413319

SYSTEM DIAGRAM

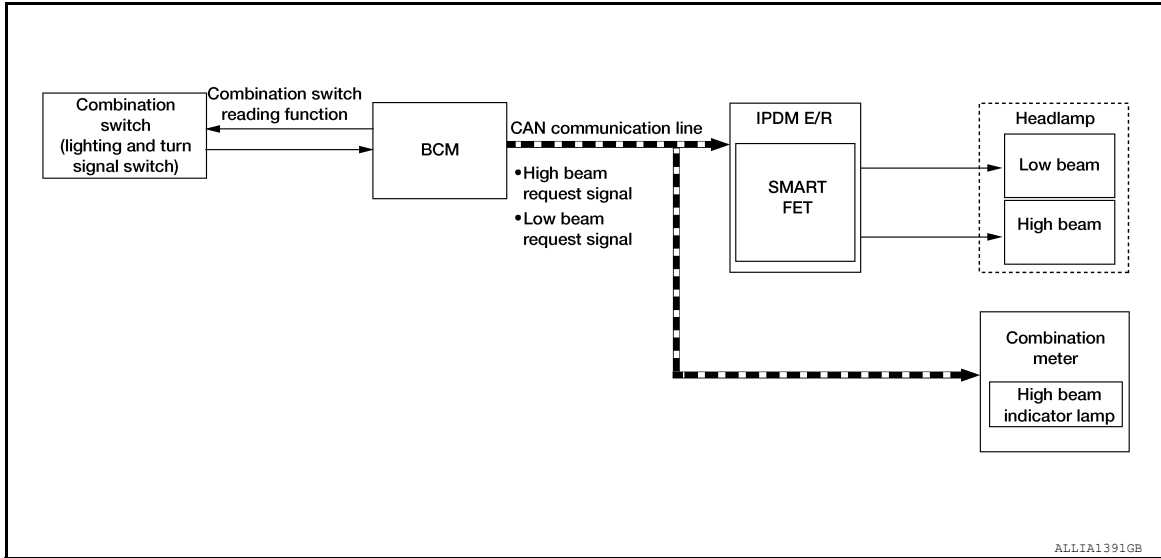

OUTLINE

Headlamp is controlled by combination switch reading function and headlamp control function of BCM, and Smart FET control function of IPDM E/R.

HEADLAMP (LO) OPERATION

- BCM detects the combination switch condition with the combination switch reading function.
- BCM transmits the low beam request signal to IPDM E/R with CAN communication according to the headlamp (LO) ON condition.

Headlamp (LO) ON condition:

- Lighting switch 2ND
- Lighting switch AUTO (auto light function ON judgment)
- Lighting switch AUTO, with the front fog lamp switch ON and the ignition switch ON
- Lighting switch PASS

HEADLAMP (HI) OPERATION

- BCM transmits the high beam request signal to IPDM E/R and the combination meter with CAN communication according to the headlamp (HI) ON condition.

Headlamp (HI) ON condition:

- Lighting switch HI with the lighting switch 2ND or AUTO (auto light function ON judgment)
- Lighting switch PASS
- Lighting switch AUTO, with the front fog lamp switch ON, the ignition switch ON and lighting switch HI
- Combination meter turns the high beam indicator lamp ON according to the high beam request signal.
- IPDM E/R turns the headlamp ON according to the high beam request signal.

HEADLAMP SYSTEM : Fail-Safe

INFOID:000000011413320

CAN COMMUNICATION CONTROL

When CAN communication with BCM is impossible, IPDM E/R performs fail-safe control. After CAN communication recovers normally, it also returns to normal control.

If no CAN communication is available with BCM

SYSTEM

< SYSTEM DESCRIPTION >

[LED HEADLAMP]

Control part	Fail-safe operation
Headlamp	<ul style="list-style-type: none">• Turns ON the headlamp low beam when the ignition switch is turned ON• Turns OFF the headlamp low beam when the ignition switch is turned OFF

AUTO LIGHT SYSTEM

AUTO LIGHT SYSTEM : System Description

INFOID:000000011413321

SYSTEM DIAGRAM

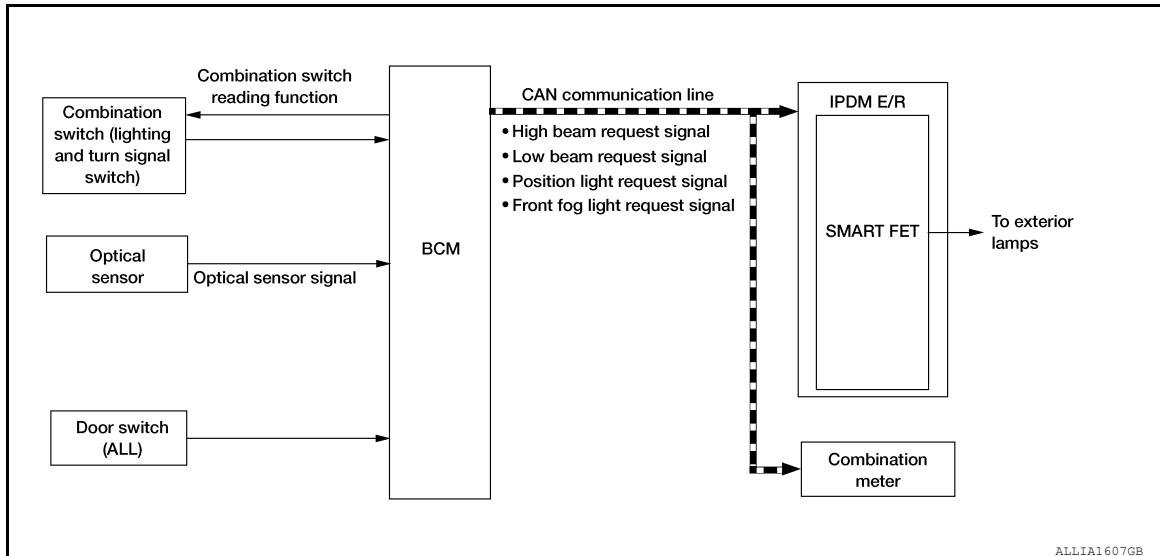

OUTLINE

- Auto light system is controlled by each function of BCM and IPDM E/R.

Controlled by BCM:

- Combination switch reading function
- Headlamp control function
- Auto light function
- Delay timer function
- Auto light adjustment system

Controlled by IPDM E/R:

- Auto light system has the auto light function and delay timer function.
- Auto light function automatically turns ON/OFF the exterior lamps* and each illumination automatically, depending on the outside brightness.
- When auto light system turns the exterior lamps ON with the ignition switch OFF, delay timer function turns the exterior lamps OFF, depending on the vehicle condition with the auto light function after a certain period of time.

*: Headlamp (LO/HI), parking lamp, side marker lamp, tail lamp and front fog lamp (Headlamp HI and front fog lamp depend on the combination switch condition).

AUTO LIGHT FUNCTION

- BCM detects the combination switch condition with the combination switch reading function.
- BCM supplies voltage to optical sensor when the ignition switch is turned ON or ACC.
- Optical sensor converts outside brightness (lux) to voltage and transmits the optical sensor signal to BCM.
- BCM judges outside brightness from the optical sensor signal and judges ON/OFF condition of the exterior lamp and each illumination according to the outside brightness.
- BCM transmits each request signal to IPDM E/R and combination meter via CAN communication according to ON/OFF condition by the auto light function.

NOTE:

ON/OFF timing differs based on the sensitivity from the setting. The setting can be set by CONSULT. Refer to [BCS-19. "HEADLAMP : CONSULT Function \(BCM - HEADLAMP\)"](#).

AUTO LIGHT ADJUSTMENT SYSTEM

A
B
C
D
E
F
G
H
I
J
K

EXL

M
N
O
P

SYSTEM

< SYSTEM DESCRIPTION >

[LED HEADLAMP]

The auto light adjustment system automatically dims/brightens the display according to brightness outside the vehicle when lighting switch 1ST, lighting switch 2ND or lighting switch AUTO is operated. Refer to [EXL-143, "AUTO LIGHT SYSTEM : System Description"](#).

DELAY TIMER FUNCTION

BCM turns the exterior lamp OFF depending on the vehicle condition with the auto light function when the ignition switch is turned OFF.

- Turns the exterior lamp OFF 5 minutes after detecting that any door opens. (Door switch ON).
- Turns the exterior lamp OFF a certain period of time* after closing all doors. (Door switch ON→OFF).
- Turns the exterior lamp OFF with the ignition switch ACC or the light switch OFF.

*: The preset time is 45 seconds. The timer operating time can be set by CONSULT. Refer to [BCS-19, "HEADLAMP : CONSULT Function \(BCM - HEADLAMP\)"](#) (with Intelligent Key system) or [BCS-90, "HEADLAMP : CONSULT Function \(BCM - HEADLAMP\)"](#) (without Intelligent Key system).

NOTE:

When any position other than the light switch AUTO is set, the auto light system function switches to the exterior lamp battery saver function.

DAYTIME RUNNING LIGHT SYSTEM

DAYTIME RUNNING LIGHT SYSTEM : System Description

INFOID:000000011413322

SYSTEM DIAGRAM

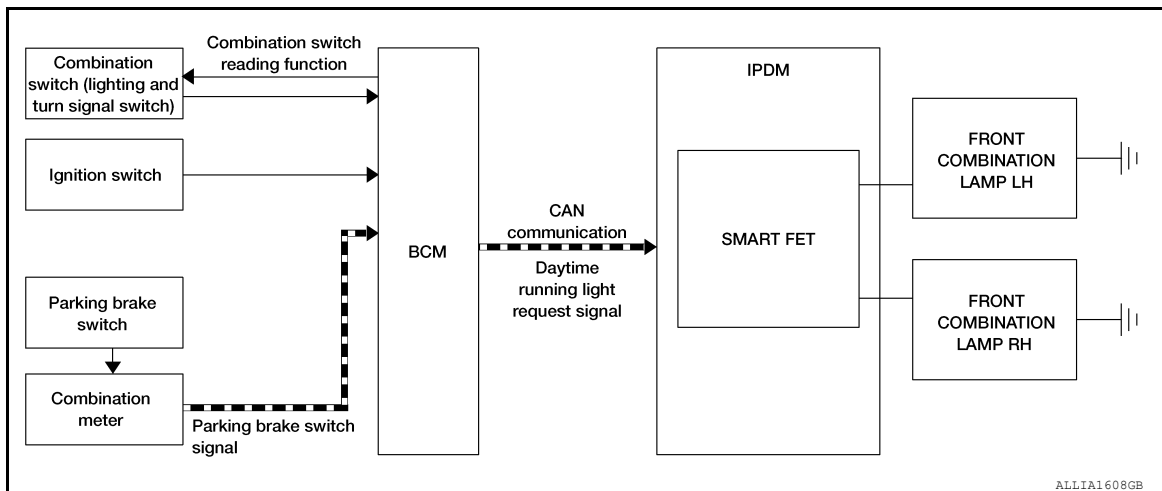

OUTLINE

- Daytime running light is controlled by daytime running light control function and combination switch reading function of BCM, and smart FET of IPDM E/R.

DAYTIME RUNNING LIGHT OPERATION

- BCM detects the combination switch condition by the combination switch reading function.
- BCM detects the vehicle condition according to ignition switch
- BCM detects the parking brake condition by the parking brake switch signal received from combination meter using CAN communication.
- BCM transmits the daytime running light request signal to IPDM E/R using CAN communication according to the daytime running light ON condition.

Daytime running light ON condition:

- Vehicle condition READY
- Lighting switch OFF or 1ST
- Lighting switch AUTO, and the auto light function OFF judgment
- Parking brake switch OFF

- IPDM E/R controls the daytime running light request signal.
- Power is supplied from the IPDM E/R to the daytime lights.

HEADLAMP AIMING CONTROL SYSTEM (AUTO)

SYSTEM

< SYSTEM DESCRIPTION >

[LED HEADLAMP]

HEADLAMP AIMING CONTROL SYSTEM (AUTO) : System Diagram

INFOID:000000011280821

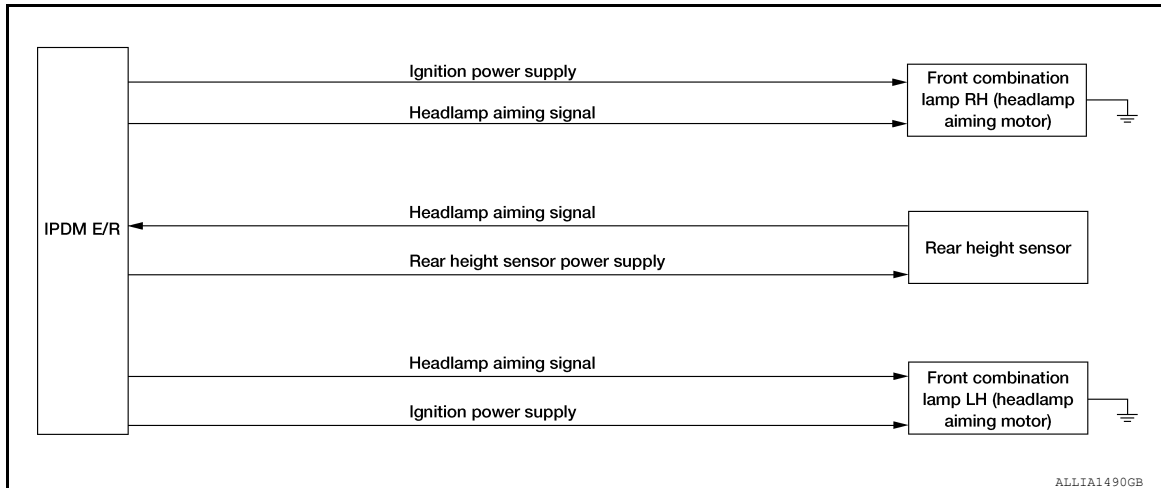

HEADLAMP AIMING CONTROL SYSTEM (AUTO) : System Description

INFOID:000000011280822

OUTLINE

- Headlamp aiming control system is controlled by the IPDM E/R.
- The IPDM E/R controls the headlamp light axis height appropriately depending on the vehicle rear height sensor position.
- Auto levelizer control unit detects the vehicle condition necessary for the aiming motor control with the following signal:
 - Rear height sensor signal

HEADLAMP AUTO AIMING OPERATION

- The IPDM E/R calculates vehicle pitch angle from the rear height sensor signal and determines the necessary correction to compensate the deviation from standard light axis position.
- The IPDM E/R outputs aiming motor drive signal when operating conditions are met.

Operating condition:

- Ignition switch ON
- Parking lamp ON
- The IPDM E/R unit changes the aiming motor drive signal when any of the correcting conditions are detected. Output is maintained if other condition is detected.

Correcting condition:

- Parking lamp is turned ON.
- Vehicle posture becomes stable after the vehicle posture change is detected with the parking lamp ON and the vehicle stopped.
- Vehicle speed is maintained with the parking lamp ON and the vehicle driven.

CAUTION:

If the suspension is worn, the adjusted axis position may differ from the preset position.

TURN SIGNAL AND HAZARD WARNING LAMP SYSTEM

TURN SIGNAL AND HAZARD WARNING LAMP SYSTEM : System Description

INFOID:000000011413323

SYSTEM DIAGRAM

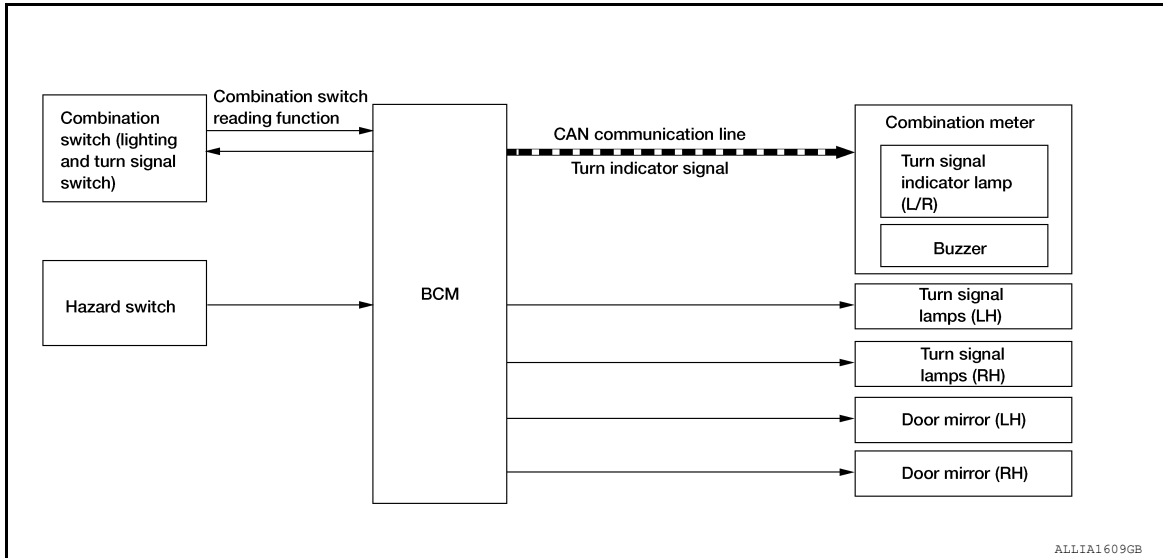

OUTLINE

Turn signal lamp and the hazard warning lamp is controlled by combination switch reading function and the flasher control function of BCM.

TURN SIGNAL LAMP OPERATION

- BCM detects the combination switch condition by the combination switch reading function.
- BCM supplies voltage to the right (left) turn signal lamp circuit when the ignition switch is ON and the turn signal switch is in the right (left) position. BCM blinks the turn signal lamp.

HAZARD WARNING LAMP OPERATION

BCM supplies voltage to both turn signal lamp circuit when the hazard switch is ON. BCM blinks the hazard warning lamp.

TURN SIGNAL INDICATOR LAMP AND TURN SIGNAL OPERATION

- BCM transmits the turn signal indicator lamp signal to the combination meter using CAN communication while the turn signal lamp and the hazard warning lamp are operating.
- Combination meter outputs the turn signal sound with the integrated buzzer while blinking the turn signal indicator lamp according to the turn signal indicator lamp signal.

HIGH FLASHER OPERATION

- BCM detects the turn signal lamp circuit status from the current value.
- BCM increases the turn signal lamp blinking speed if the bulb or harness open is detected with the turn signal lamp operating.

NOTE:

The blinking speed is normal while operating the hazard warning lamp.

PARKING, LICENSE PLATE, SIDE MARKER AND TAIL LAMP SYSTEM

PARKING, LICENSE PLATE, SIDE MARKER AND TAIL LAMP SYSTEM : System De-

SYSTEM

< SYSTEM DESCRIPTION >

[LED HEADLAMP]

scription

INFOID:000000011413324

SYSTEM DIAGRAM

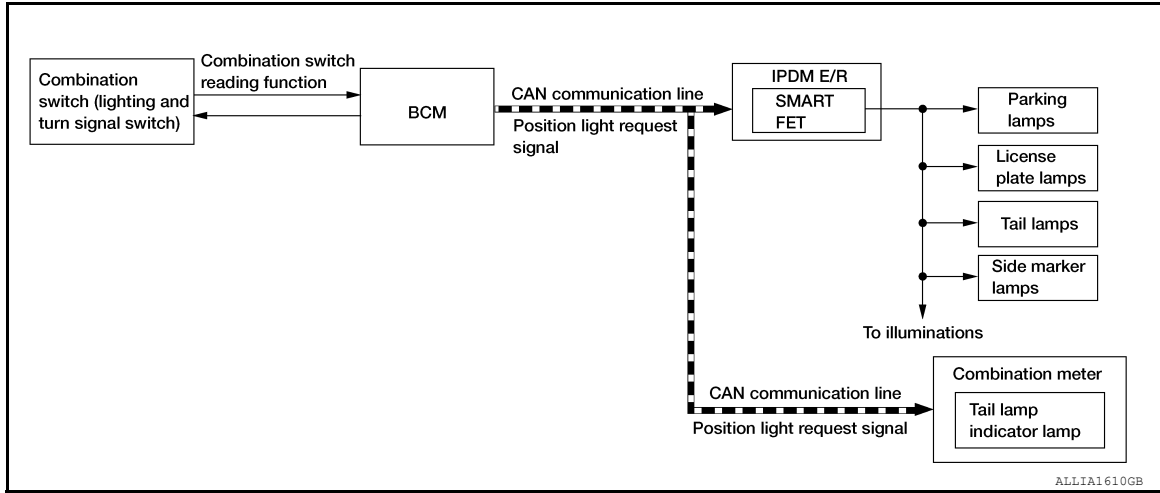

OUTLINE

Parking, license plate, side marker and tail lamps are controlled by combination switch reading function and headlamp control function of BCM, and smart FET of IPDM E/R.

PARKING, LICENSE PLATE, SIDE MARKER AND TAIL LAMPS OPERATION

- BCM detects the combination switch condition by the combination switch reading function.
- BCM transmits the position light request signal to IPDM E/R and the combination meter via CAN communication according to the ON/OFF condition of the parking, license plate, side marker and tail lamps.

Parking, license plate, side marker and tail lamps ON condition:

- Lighting switch 1ST
- Lighting switch 2ND
- Lighting switch AUTO, and the auto light function ON judgment
- Lighting switch AUTO, with the front fog lamp switch ON and the ignition switch ON
- IPDM E/R turns the parking, license plate, side marker and tail lamps ON according to the position light request signal.
- Combination meter turns the tail lamp indicator lamp ON according to the position light request signal.

PARKING, LICENSE PLATE, SIDE MARKER AND TAIL LAMP SYSTEM : Fail-Safe

INFOID:000000011413325

CAN COMMUNICATION CONTROL

When CAN communication with BCM is impossible, IPDM E/R performs fail-safe control. After CAN communication recovers normally, it also returns to normal control.

If no CAN communication is available with BCM

Control part	Fail-safe operation
<ul style="list-style-type: none"> • Parking lamp • License plate lamp • Illumination • Tail lamp • Side marker lamp 	<ul style="list-style-type: none"> • Turns ON the tail lamp when the ignition switch is turned ON • Turns OFF the tail lamp when the ignition switch is turned OFF

FRONT FOG LAMP SYSTEM

A
B
C
D
E
F
G
H
I
J
K
L
M
N
O
P

EXL

SYSTEM

< SYSTEM DESCRIPTION >

[LED HEADLAMP]

FRONT FOG LAMP SYSTEM : System Description

INFOID:000000011413326

SYSTEM DIAGRAM

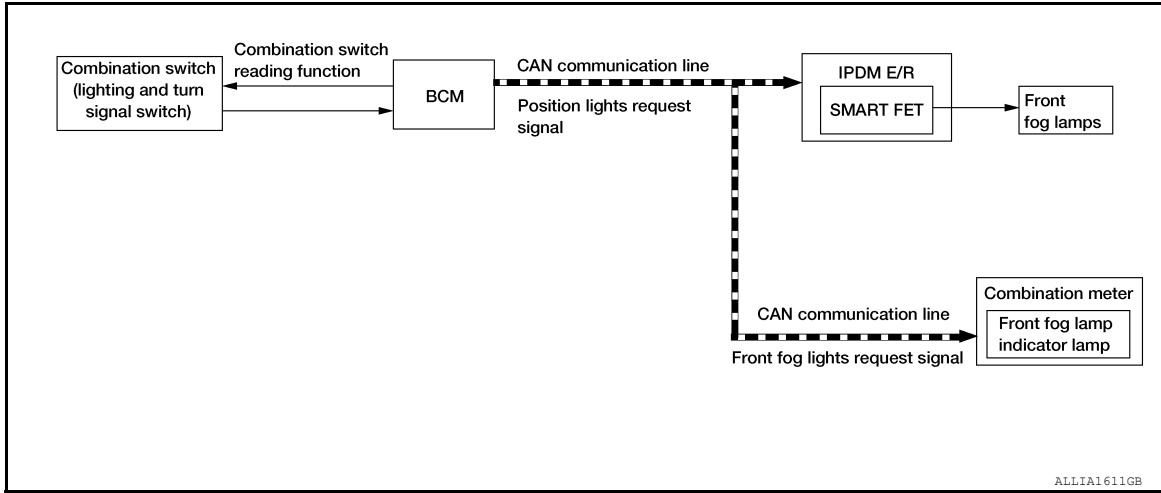

OUTLINE

Front fog lamp is controlled by combination switch reading function, front fog lamp control function of BCM, and smart FET function of IPDM E/R.

FRONT FOG LAMP OPERATION

- BCM detects the combination switch condition by the combination switch reading function.
- BCM transmits the front fog lights request signal to IPDM E/R and the combination meter via CAN communication according to the front fog lamp ON condition.

Front fog lamp ON condition:

- Front fog lamp switch ON, and any of the following conditions are satisfied (except for the high beam ON):
- Lighting switch 2ND
- Lighting switch AUTO and the ignition switch ON

IPDM E/R turns the front fog lamp ON according to the front fog lights request signal.

Combination meter turns the front fog lamp indicator lamp ON according to the front fog lights request signal.

FRONT FOG LAMP SYSTEM : Fail-Safe

INFOID:000000011413327

CAN COMMUNICATION CONTROL

When CAN communication with BCM is impossible, IPDM E/R performs fail-safe control. After CAN communication recovers normally, it also returns to normal control.

If no CAN communication is available with BCM

Control part	Fail-safe operation
Front fog lamp	Front fog lamp OFF

EXTERIOR LAMP BATTERY SAVER SYSTEM

EXTERIOR LAMP BATTERY SAVER SYSTEM : System Description

INFOID:000000011413328

SYSTEM DIAGRAM

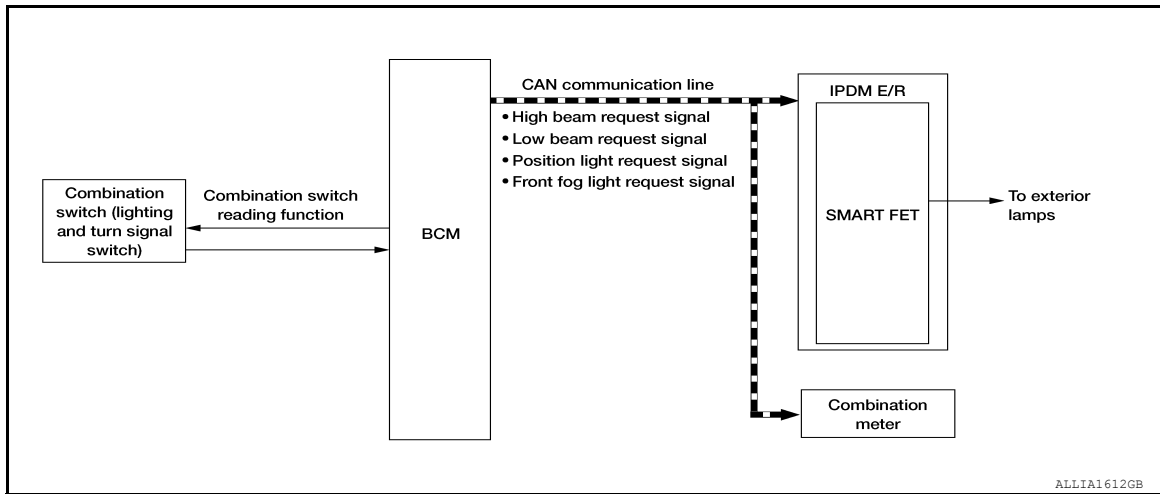

OUTLINE

- Exterior lamp battery saver system is controlled by each function of BCM and IPDM E/R.

Controlled by BCM:

- Combination switch reading function
- Headlamp control function
- Exterior lamp battery saver function

Controlled by IPDM E/R:

- BCM turns the exterior lamps* OFF after a period of time to prevent the battery from over-discharge when the ignition switch is turned OFF with the exterior lamps ON.

*: Headlamp (LO/HI), parking lamp, tail lamp, side marker lamp, license plate lamp and front fog lamp

EXTERIOR LAMP BATTERY SAVER ACTIVATION

BCM activates the timer and turns the exterior lamp OFF 5 minutes after the ignition switch is turned from ON → OFF with the exterior lamps ON.

NOTE:

- Headlamp control function turns the exterior lamps ON normally when the ignition switch is turned ACC or set the vehicle to READY (both before and after the exterior lamp battery saver is turned OFF).
- The timer starts at the time that the lighting switch is turned from OFF → 1ST or 2ND with the exterior lamps OFF.

A
B
C
D
E
F
G
H
I
J
K
EXL
M
N
O
P

DIAGNOSIS SYSTEM (BCM)

[LED HEADLAMP]

< SYSTEM DESCRIPTION >

DIAGNOSIS SYSTEM (BCM) WITH INTELLIGENT KEY

WITH INTELLIGENT KEY : CONSULT Function (BCM - COMMON ITEM) INFOID:0000000011421486

APPLICATION ITEM

CONSULT performs the following functions via CAN communication with BCM.

Direct Diagnostic Mode	Description
Ecu Identification	The BCM part number is displayed.
Self Diagnostic Result	The BCM self diagnostic results are displayed.
Data Monitor	The BCM input/output data is displayed in real time.
Active Test	The BCM activates outputs to test components.
Work support	The settings for BCM functions can be changed.
Configuration	<ul style="list-style-type: none"> The vehicle specification can be read and saved. The vehicle specification can be written when replacing BCM.
CAN Diag Support Mntr	The result of transmit/receive diagnosis of CAN communication is displayed.

SYSTEM APPLICATION

BCM can perform the following functions.

System	Sub System	Direct Diagnostic Mode						
		Ecu Identification	Self Diagnostic Result	Data Monitor	Active Test	Work support	Configuration	CAN Diag Support Mntr
Door lock	DOOR LOCK		×	×	×	×		
Rear window defogger	REAR DEFOGGER			×	×	×		
Warning chime	BUZZER			×	×			
Interior room lamp timer	INT LAMP			×	×	×		
Exterior lamp	HEADLAMP			×	×	×		
Wiper and washer	WIPER			×	×	×		
Turn signal and hazard warning lamps	FLASHER			×	×			
Intelligent Key system	INTELLIGENT KEY		×	×	×	×		
Combination switch	COMB SW			×				
BCM	BCM	×	×			×	×	×
Immobilizer	IMMU		×	×	×			
Interior room lamp battery saver	BATTERY SAVER			×	×			
Back door open	TRUNK			×				
Vehicle security system	THEFT ALM			×	×	×		
RAP system	RETAINED PWR			×				
Signal buffer system	SIGNAL BUFFER			×				
Air conditioner	AIR CONDITIONER				×			

WITH INTELLIGENT KEY : CONSULT Function (BCM - HEADLAMP) INFOID:0000000011421487

DATA MONITOR

DIAGNOSIS SYSTEM (BCM)

< SYSTEM DESCRIPTION >

[LED HEADLAMP]

Monitor Item [Unit]	Description	A
PUSH SW [On/Off]	Indicates condition of push-button ignition switch.	A
ENGINE STATE [STOP/STALL/CRANK/RUN]	Indicates engine status received from ECM on CAN communication line.	B
VEH SPEED 1 [km/h]	Indicates vehicle speed signal received from ABS on CAN communication line.	C
TURN SIGNAL R [On/Off]	Indicates condition of combination switch.	C
TURN SIGNAL L [On/Off]		D
TAIL LAMP SW [On/Off]		E
HI BEAM SW [On/Off]		F
HEAD LAMP SW [On/Off]		F
LIGHT OFF SW [On/Off]		E
PASSING SW [On/Off]		F
AUTO LIGHT SW [On/Off]		F
FR FOG SW [On/Off]		F
DOOR SW-DR [On/Off]	Indicates condition of front door switch LH.	G
DOOR SW-AS [On/Off]	Indicates condition of front door switch RH.	G
DOOR SW-RR [On/Off]	Indicates condition of rear door switch RH.	H
DOOR SW-RL [On/Off]	Indicates condition of rear door switch LH.	H
DOOR SW-BK [On/Off]	Indicates condition of back door switch.	I
OPTI SEN (DTCT) [V]	Indicates outside brightness voltage signal from optical sensor.	I
OPTI SEN (FILT) [V]	Indicates outside brightness voltage signal from optical sensor filtered by BCM.	I
OPTICAL SENSOR [On/Off]	Indicates condition of optical sensor.	I

ACTIVE TEST

Test Item	Description	J
FR FOG LAMP	This test is able to check front fog lamp operation [On/Off].	J
STOP LAMP 1	This test is able to check rear combination lamp stop lamp operation [On/Off].	K
STOP LAMP 3	This test is able to check high-mounted stop lamp operation [On/Off].	K
DAYTIME RUNNING LIGHT	This test is able to check daytime running light operation [On/Off].	EXL
ILL DIM SIGNAL	This test is able to check illumination dimmer signal [On/Off].	EXL

WORK SUPPORT

Support Item	Setting	Description	M
TWILIGHT ON	MODE2*	Autolamp function ON.	M
	MODE1	Autolamp function OFF.	N
CUSTOM A/LIGHT SETTING	MODE4	Less sensitive than normal setting (turns ON later).	O
	MODE3	More sensitive than MODE2.	O
	MODE2	More sensitive than normal setting (turns ON earlier).	O
	MODE1*	Normal setting.	P

DIAGNOSIS SYSTEM (BCM)

< SYSTEM DESCRIPTION >

[LED HEADLAMP]

Support Item	Setting	Description
ILL DELAY SET	MODE 8	Autolamp delay timer.
	MODE 7	
	MODE 6	
	MODE 4	
	MODE 5	
	MODE 3	
	MODE 2	
	MODE 1*	

*: Initial setting

WITH INTELLIGENT KEY : CONSULT Function (BCM - FLASHER)

INFOID:000000011421488

DATA MONITOR

Monitor Item [Unit]	Description
REQ SW -DR [On/Off]	Indicates condition of door request switch LH.
REQ SW -AS [On/Off]	Indicates condition of door request switch RH.
PUSH SW [On/Off]	Indicates condition of push-button ignition switch.
TURN SIGNAL R [On/Off]	Indicates condition of turn signal function of combination switch.
TURN SIGNAL L [On/Off]	
HAZARD SW [On/Off]	Indicates condition of hazard switch.
RKE-LOCK [On/Off]	Indicates condition of lock signal from Intelligent Key.
RKE-UNLOCK [On/Off]	Indicates condition of unlock signal from Intelligent Key.
RKE-PANIC [On/Off]	Indicates condition of panic alarm signal from Intelligent Key.

WORK SUPPORT

Support Item	Setting	Description
3-TIME FLASHER SETTING	On*	3-time flasher setting ON.
	Off	3-time flasher setting OFF.

*: Initial setting

WITHOUT INTELLIGENT KEY

WITHOUT INTELLIGENT KEY : CONSULT Function (BCM - COMMON ITEM)

INFOID:000000011421489

APPLICATION ITEM

CONSULT performs the following functions via CAN communication with BCM.

Direct Diagnostic Mode	Description
Ecu Identification	The BCM part number is displayed.
Self Diagnostic Result	The BCM self diagnostic results are displayed.
Data Monitor	The BCM input/output data is displayed in real time.
Active Test	The BCM activates outputs to test components.
Work support	The settings for BCM functions can be changed.
Configuration	<ul style="list-style-type: none"> • The vehicle specification can be read and saved. • The vehicle specification can be written when replacing BCM.
CAN Diag Support Mntr	The result of transmit/receive diagnosis of CAN communication is displayed.

DIAGNOSIS SYSTEM (BCM)

< SYSTEM DESCRIPTION >

[LED HEADLAMP]

SYSTEM APPLICATION

BCM can perform the following functions.

System	Sub System	Direct Diagnostic Mode						
		Ecu Identification	Self Diagnostic Result	Data Monitor	Active Test	Work support	Configuration	CAN Diag Support Mntr
Door lock	DOOR LOCK			×	×	×		
Rear window defogger	REAR DEFOGGER			×	×	×		
Warning chime	BUZZER			×	×			
Interior room lamp timer	INT LAMP			×	×	×		
Remote keyless entry system	MULTI REMOTE ENT					×		
Exterior lamp	HEADLAMP			×	×			
Wiper and washer	WIPER			×	×	×		
Turn signal and hazard warning lamps	FLASHER			×	×			
Combination switch	COMB SW			×				
BCM	BCM	×	×			×	×	×
Immobilizer	IMMU		×		×			
Interior room lamp battery saver	BATTERY SAVER			×	×			
Back door open	TRUNK			×				
Vehicle security system	THEFT ALM			×	×	×		
RAP system	RETAINED PWR			×				
TPMS	AIR PRESSURE MONITOR		×	×	×	×		

WITHOUT INTELLIGENT KEY : CONSULT Function (BCM - HEADLAMP) INFOID:000000011421490

DATA MONITOR

Monitor Item [Unit]	Description
TURN SIGNAL R [On/Off]	Indicates condition of combination switch.
TURN SIGNAL L [On/Off]	
TAIL LAMP SW [On/Off]	
HI BEAM SW [On/Off]	
HEAD LAMP SW [On/Off]	
LIGHT OFF SW [On/Off]	
PASSING SW [On/Off]	
DOOR SW-DR [On/Off]	Indicates condition of front door switch LH.
DOOR SW-AS [On/Off]	Indicates condition of front door switch RH.
DOOR SW-RR [On/Off]	Indicates condition of rear door switch RH.
DOOR SW-RL [On/Off]	Indicates condition of rear door switch LH.
DOOR SW-BK [On/Off]	Indicates condition of back door switch.

ACTIVE TEST

DIAGNOSIS SYSTEM (BCM)

< SYSTEM DESCRIPTION >

[LED HEADLAMP]

Test Item	Description
DAYTIME RUNNING LIGHT	This test is able to check daytime running lamp operation [On/Off].
ILL DIM SIGNAL	This test is able to check head lamp illumination dimming operation [On/Off].

WITHOUT INTELLIGENT KEY : CONSULT Function (BCM - FLASHER)

INFOID:000000011421491

DATA MONITOR

Monitor Item [Unit]	Description
TURN SIGNAL R [On/Off]	Indicates condition of turn signal function of combination switch.
TURN SIGNAL L [On/Off]	
HAZARD SW [On/Off]	Indicates condition of hazard switch.
RKE-LOCK [On/Off]	Indicates condition of lock signal from Intelligent Key.
RKE-UNLOCK [On/Off]	Indicates condition of unlock signal from Intelligent Key.
RKE-PANIC [On/Off]	Indicates condition of panic alarm signal from Intelligent Key.

ACTIVE TEST

Test Item	Description
FLASHER	This test is able to check turn signal lamp operation [Off/LH/RH].

DIAGNOSIS SYSTEM (IPDM E/R)

< SYSTEM DESCRIPTION >

[LED HEADLAMP]

DIAGNOSIS SYSTEM (IPDM E/R)

CONSULT Function (IPDM E/R)

INFOID:0000000011421492

APPLICATION ITEM

CONSULT performs the following functions via CAN communication with IPDM E/R.

Direct Diagnostic Mode	Description
ECU Identification	The IPDM E/R part number is displayed.
Self Diagnostic Result	The IPDM E/R self diagnostic results are displayed.
Data Monitor	The IPDM E/R input/output data is displayed in real time.
Active Test	The IPDM E/R activates outputs to test components.
CAN Diag Support Mntr	The result of transmit/receive diagnosis of CAN communication is displayed.

ECU IDENTIFICATION

The IPDM E/R part number is displayed.

SELF DIAGNOSTIC RESULT

Refer to [PCS-22, "DTC Index"](#).

DATA MONITOR

Monitor Item [Unit]	Description
REVERSE SIGNAL [Open/Close]	Indicates condition of transmission range switch R (Reverse) position.
IGN RELAY [Open/Close]	Indicates condition of ignition relay-1.
PUSH SW [Open/Close]	Indicates condition of push-button ignition switch.
INTERLOCK/PNP SW [Open/Close]	Indicates condition of transmission range switch P (Park) and N (Neutral) positions.
OIL PRESSURE SW [Open/Close]	Indicates condition of oil pressure switch.
HOOD SW [Open/Close]	Indicates condition of hood switch.
COMPRESSOR [OFF/ON]	Indicates condition of A/C compressor.
HORN RELAY [OFF/ ON]	Indicates condition of horn relay.
COOLING FAN [OFF/ON]	Indicates condition of cooling fan relay-1.
FRONT WIPER HI/LO RELAY [OFF/ON]	Indicates condition of front wiper high relay.
FRONT WIPER RELAY [OFF/ON]	Indicates condition of front wiper relay.
IGN RELAY OFF STATUS [OFF/ON]	Indicates condition of ignition relay-1 OFF status.
IGN RELAY ON STATUS [OFF/ON]	Indicates condition of ignition relay-1 ON status.
COOLING FAN RELAY 1 [OFF/ON]	Indicates condition of cooling fan relay-1.
STARTER RELAY [OFF/ON]	Indicates condition of starter relay.
COMP ECV DUTY [%]	Indicates condition of A/C compressor.
COOLING FAN RELAY 2 [%]	Indicates condition of cooling fan relay-2.
FR FOG LAMP LH [%]	Indicates condition of front fog lamp LH.
FR FOG LAMP RH [%]	Indicates condition of front fog lamp RH.
PARKING LAMP [%]	Indicates condition of parking lamp.
TAIL LAMP LH [%]	Indicates condition of tail lamp LH.
TAIL LAMP RH [%]	Indicates condition of tail lamp RH.
DAYTIME RUNNING LIGHT LH [%]	Indicates condition of daytime running light LH.
DAYTIME RUNNING LIGHT RH [%]	Indicates condition of daytime running light RH.
HEADLAMP (HI) LH [%]	Indicates condition of headlamp high beam LH.

DIAGNOSIS SYSTEM (IPDM E/R)

[LED HEADLAMP]

< SYSTEM DESCRIPTION >

Monitor Item [Unit]	Description
HEADLAMP (HI) RH [%]	Indicates condition of headlamp high beam RH.
HEADLAMP (LO) LH [%]	Indicates condition of headlamp low beam LH.
HEADLAMP (LO) RH [%]	Indicates condition of headlamp low beam RH.
A/C RELAY STUCK [NG/OK]	Indicates condition of A/C relay.
A/C RELAY [Off/On]	Indicates condition of A/C relay.
COMP ECV STATUS [NG/OK]	Indicates condition of A/C compressor.
VEHICLE SECURITY HORN [Off/On]	Indicates condition of horn relay.
BATTERY CURRENT SENSOR [NG/OK]	Indicates condition of battery current sensor.
FRONT FOG LAMP [Off/On]	Indicates condition of front fog lamps.
COMP ECV CURRENT [A]	Indicates condition of A/C compressor current.
BATTERY VOLTAGE [V]	Indicates condition of battery voltage.
COOLING FAN DUTY [%]	Indicates condition of cooling fans.
HOOD SW (CAN) [OPEN/CLOSE]	Indicates condition of hood switch.
FRONT WIPER [STOP/LOW/HIGH]	Indicates condition of front wiper motor.
FR WIPER STOP POSITION [STOP P/ACTIVE P]	Indicates condition of front wiper motor stop.
HEADLAMP (HI) [Off/On]	Indicates condition of headlamp high beams.
HEADLAMP (LO) [Off/On]	Indicates condition of headlamp low beams.
IGNITION RELAY STATUS [Off/On]	Indicates condition of ignition relay-1.
IGN RELAY MONITOR [Off/On]	Indicates condition of ignition relay-1 feedback.
IGNITION POWER SUPPLY [Off/On]	Indicates condition of ignition relay-1.
INTERLOCK/PNP SW (CAN) [Off/On]	Indicates condition of transmission range switch P (Park) and N (Neutral) positions.
PUSH-BUTTON IGN SW (CAN) [Off/On]	Indicates condition of push-button ignition switch.
TAIL LAMP [Off/On]	Indicates condition of tail lamps.
REVERSE SIGNAL (CAN) [Off/On]	Indicates condition of transmission range switch R (Reverse) position.
ST&ST CONT RELAY STATUS [Off/ST R On]	Indicates condition of starter cut and starter relays.
STARTER MOTOR STATUS [Off/On]	Indicates condition of starter motor.
STARTER RELAY (CAN) [LOW/HIGH]	Indicates condition of starter relay.
IPDM NOT SLEEP [NO RDY/RDY]	Indicates condition of IPDM E/R sleep status.
AFTER COOLING TIME [No request/Request]	Indicates condition of cooling fan request.
AFTER COOLING SPEED [%]	Indicates condition of cooling fans.
COOLING FAN TYPE [NISSAN/RENAULT]	Indicates cooling fan type.
COMPRESSOR REQ1 [Off/On]	Indicates condition of A/C compressor request.
VHCL SECURITY HORN REQ [Off/On]	Indicates condition of horn relay request.
DTRL REQ [Off/On]	Indicates condition of daytime running light request.
SLEEP/WAKE UP [WAKEUP/SLEEP]	Indicates condition of IPDM E/R sleep/wake.
CRANKING ENABLE-TCM [NG/OK]	Indicates condition of crank enable from TCM.
CRANKING ENABLE-ECM [NG/OK]	Indicates condition of crank enable from ECM.
CAN DIAGNOSIS [NG/OK]	Indicates condition of CAN diagnosis.
FRONT FOG LAMP REQ [Off/On]	Indicates condition of front fog lamp request.
HIGH BEAM REQ [Off/On]	Indicates condition of headlamp high beam request.
HORN CHIRP [Off/On]	Indicates condition of horn relay request.
COOLING FAN REQ [%]	Indicates condition of cooling fan request.
ENGINE STATUS [STOP/RUN/IDLING]	Indicates condition of engine status.

DIAGNOSIS SYSTEM (IPDM E/R)

< SYSTEM DESCRIPTION >

[LED HEADLAMP]

Monitor Item [Unit]	Description
TURN SIGNAL REQ [Off/LH/RH]	Indicates condition of turn signal request.
FR WIPER REQ [RETURN/LOW/HIGH]	Indicates condition of front wiper motor request.
SHIFT POSITION [P/R/N/D/L]	Indicates condition of transmission range switch positions.
LOW BEAM REQ [Off/On]	Indicates condition of headlamp low beam request.
POSITION LIGHT REQ [Off/On]	Indicates condition of parking lamp request.
COMPRESSOR REQ2 [Off/On]	Indicates condition of A/C compressor request.
IGNITION SW [Off/On]	Indicates condition of ignition switch.
VEHICLE SPEED (METER) [mph/km/h]	Indicates vehicle speed.
BAT DISCHARGE COUNT [0-100]	Indicates condition of battery discharge.
BATTERY STATUS [NG/OK]	Indicates battery status.

ACTIVE TEST

Test item	Description
HORN	This test is able to check horn operation [Off/On].
FRONT WIPER	This test is able to check wiper motor operation [Off/Low/High].
COMPRESSOR	This test is able to check A/C compressor operation [Off/On].
COOLING FAN (DUAL)	This test is able to check cooling fan operation [Off/LO/HI].
HEADLAMP (HI)	This test is able to check headlamp high beam operation [Off/3/5].
HEADLAMP (LO)	This test is able to check headlamp low beam operation [Off/3/5].
FRONT FOG LAMP	This test is able to check front fog lamp operation [Off/3/5].
DAYTIME RUNNING LAMP	This test is able to check daytime running lamp operation [Off/3/5].
PARKING LAMP	This test is able to check parking lamp operation [Off/3/5].
TAIL LAMP	This test is able to check tail lamp operation [Off/3/5].

CAN DIAG SUPPORT MNTR

Refer to [LAN-14, "CAN Diagnostic Support Monitor"](#).

A
B
C
D
E
F
G
H
I
J
K

EXL

M
N
O
P

ECU DIAGNOSIS INFORMATION

BCM, IPDM E/R

List of ECU Reference

INFOID:000000011421493

ECU	Reference
BCM (with Intelligent Key system)	BCS-28, "Reference Value"
	BCS-46, "Fail Safe"
	BCS-46, "DTC Inspection Priority Chart"
	BCS-47, "DTC Index"
BCM (without Intelligent Key system)	BCS-96, "Reference Value"
	BCS-107, "Fail Safe"
	BCS-107, "DTC Inspection Priority Chart"
	BCS-108, "DTC Index"
IPDM E/R	PCS-14, "Reference Value".
	PCS-21, "Fail-safe"
	PCS-22, "DTC Index"

HEADLAMP

[LED HEADLAMP]

< WIRING DIAGRAM >

WIRING DIAGRAM

HEADLAMP

Wiring Diagram

INFOID:0000000011280837

HEADLAMP - LED

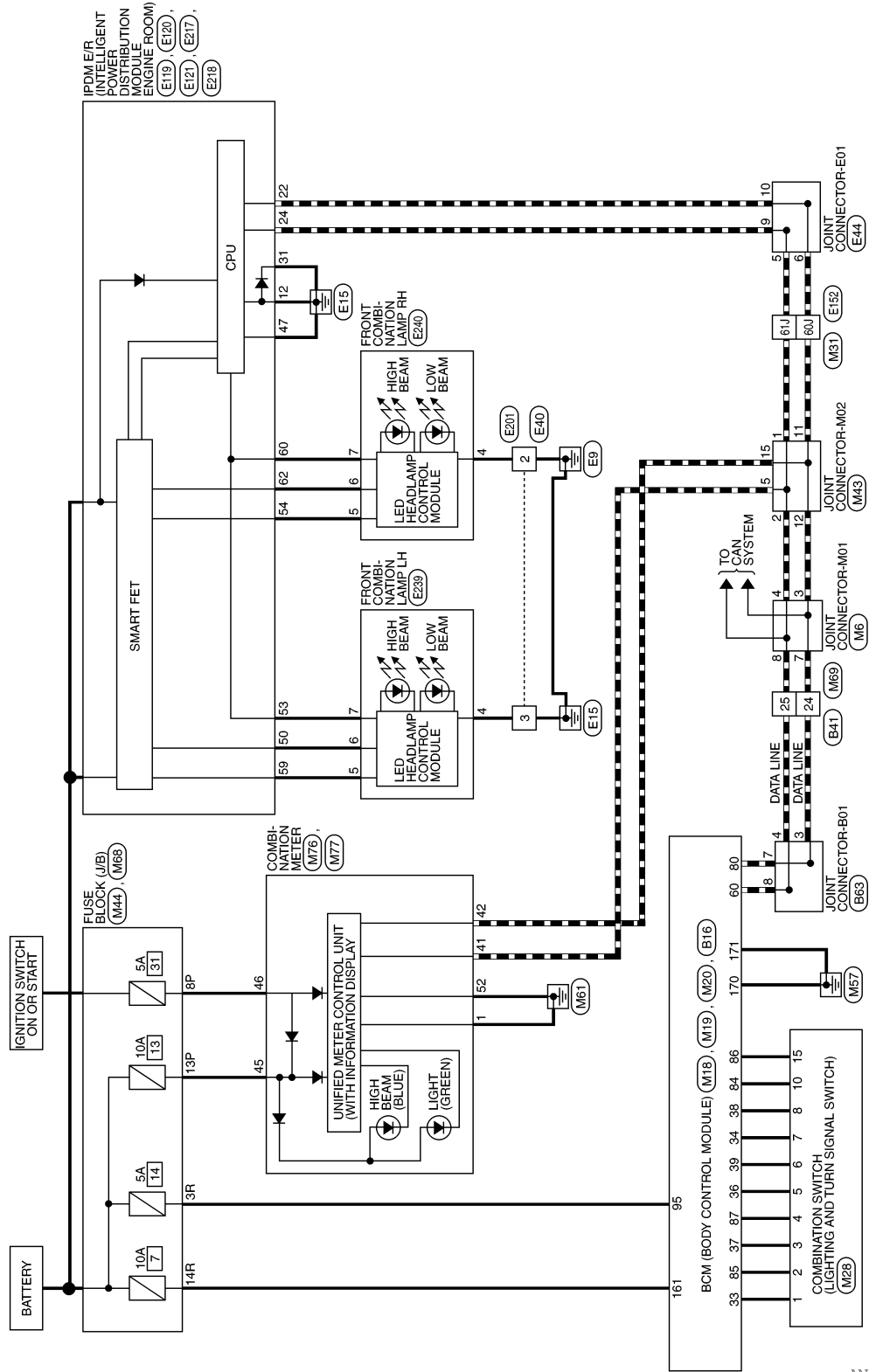

AALWA1051GB

A
B
C
D
E
F
G
H
I
J
K
EXL
M
N
O
P

HEADLAMP

< WIRING DIAGRAM >

[LED HEADLAMP]

HEADLAMP CONNECTORS - LED

Connector No.	M6
Connector Name	JOINT CONNECTOR-M01
Connector Color	GRAY

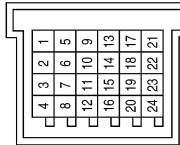

Terminal No.	Color of Wire	Signal Name
3	P	-
4	L	-
7	P	-
8	L	-

Connector No.	M18
Connector Name	BCM (BODY CONTROL MODULE)
Connector Color	GRAY

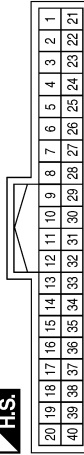

Terminal No.	Color of Wire	Signal Name
33	LG	I CSW 5
34	Y	O CSW 5
36	G	I CSW 3
37	GR	I CSW 4
38	V	I CSW 1
39	W	I CSW 2

Connector No.	M19
Connector Name	BCM (BODY CONTROL MODULE)
Connector Color	BLACK

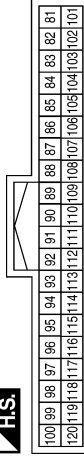

Terminal No.	Color of Wire	Signal Name
84	BR	O CSW 2
85	SB	O CSW 1
86	P	O CSW 3
87	BG	O CSW 4
95	V	I SHORTING PIN

Connector No.	M20
Connector Name	BCM (BODY CONTROL MODULE)
Connector Color	BROWN



Terminal No.	Color of Wire	Signal Name
161	W	I PWR ECU
170	B	I GND1
171	B	I GND2

Connector No.	M28
Connector Name	COMBINATION SWITCH (LIGHTING AND TURN SIGNAL SWITCH)
Connector Color	WHITE

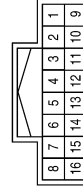

Terminal No.	Color of Wire	Signal Name
1	LG	-
2	SB	-
3	GR	-
4	BG	-

Terminal No.	Color of Wire	Signal Name
5	G	-
6	W	-
7	Y	-
8	V	-
10	BR	-
15	P	-

HEADLAMP

< WIRING DIAGRAM >

[LED HEADLAMP]

Connector No.	M43
Connector Name	JOINT CONNECTOR-M02
Connector Color	BLUE

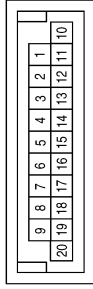

Terminal No.	Color of Wire	Signal Name
1	L	-
2	L	-
5	L	-
11	P	-
12	P	-
15	P	-

Terminal No.	Color of Wire	Signal Name
60J	P	-
61J	L	-

Connector No.	M31
Connector Name	WIRE TO WIRE
Connector Color	WHITE

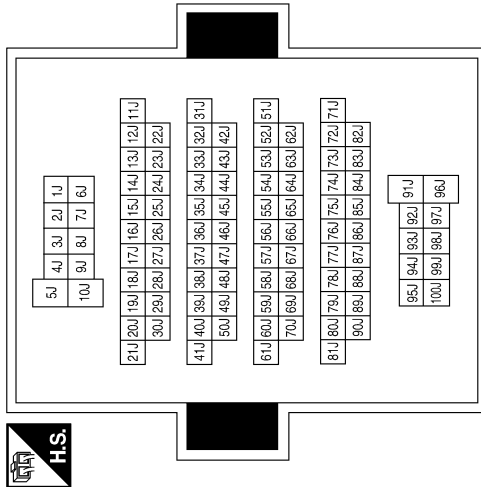

Connector No.	M69
Connector Name	WIRE TO WIRE
Connector Color	WHITE

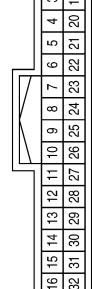

Terminal No.	Color of Wire	Signal Name
24	P	-
25	L	-

Connector No.	M68
Connector Name	FUSE BLOCK (J/B)
Connector Color	BROWN



Terminal No.	Color of Wire	Signal Name
3R	V	-
14R	W	-

Connector No.	M44
Connector Name	FUSE BLOCK (J/B)
Connector Color	WHITE



Terminal No.	Color of Wire	Signal Name
8P	LA/BR	-
13P	LA/G	-

AALIA2983GB

A
B
C
D
E
F
G
H
I
J
K
L
M
N
O
P

EXL

HEADLAMP

< WIRING DIAGRAM >

[LED HEADLAMP]

Connector No.	E40
Connector Name	WIRE TO WIRE
Connector Color	WHITE



Terminal No.	Color of Wire	Signal Name
2	GR	-
3	B	-

Connector No.	M77
Connector Name	COMBINATION METER
Connector Color	WHITE

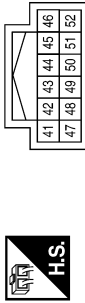

Terminal No.	Color of Wire	Signal Name
41	L	CAN-H
42	P	CAN-L
45	LA/G	BAT
46	LA/BR	IGN
52	B	G1

Connector No.	M76
Connector Name	COMBINATION METER
Connector Color	WHITE

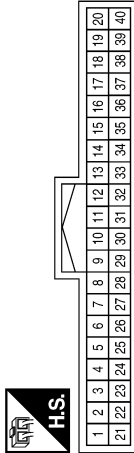

Terminal No.	Color of Wire	Signal Name
1	B	GND

Connector No.	E120
Connector Name	IPDM E/R (INTELLIGENT POWER DISTRIBUTION MODULE ENGINE ROOM)
Connector Color	GRAY

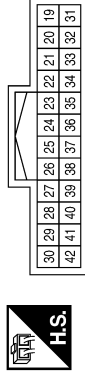

Terminal No.	Color of Wire	Signal Name
22	P	CAN-L
24	L	CAN-H
31	B	2ND SIGNAL GROUND

Connector No.	E119
Connector Name	IPDM E/R (INTELLIGENT POWER DISTRIBUTION MODULE ENGINE ROOM)
Connector Color	GRAY



Terminal No.	Color of Wire	Signal Name
12	B	SIGNAL GROUND

Connector No.	E44
Connector Name	JOINT CONNECTOR-E01
Connector Color	WHITE

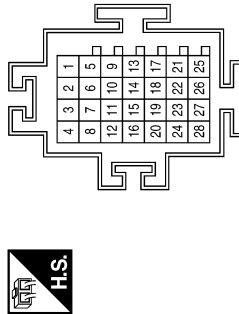

Terminal No.	Color of Wire	Signal Name
5	L	-
6	P	-
9	L	-
10	P	-

AALIA2984GB

HEADLAMP

< WIRING DIAGRAM >

[LED HEADLAMP]

Terminal No.	Color of Wire	Signal Name
60J	P	-
61J	L	-

Connector No.	E152
Connector Name	WIRE TO WIRE
Connector Color	WHITE

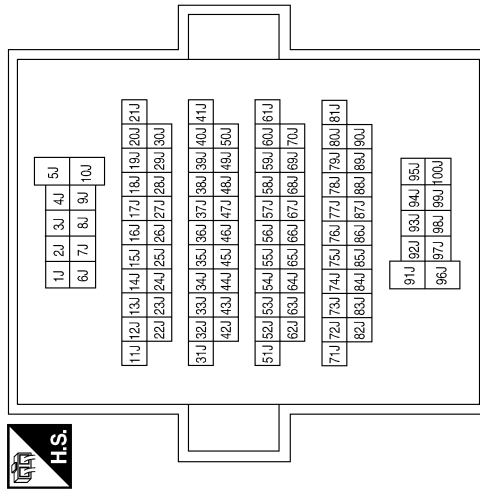

Connector No.	E121
Connector Name	IPDM E/R (INTELLIGENT POWER DISTRIBUTION MODULE ENGINE ROOM)
Connector Color	RED



Terminal No.	Color of Wire	Signal Name
47	B	POWER GROUND

Connector No.	E218
Connector Name	IPDM E/R (INTELLIGENT POWER DISTRIBUTION MODULE ENGINE ROOM)
Connector Color	WHITE



Terminal No.	Color of Wire	Signal Name
59	G	O LIGHT HBEAM LH
60	Y	LI LED DETECTION 1
62	SB	O LIGHT LBEAM RH

Connector No.	E217
Connector Name	IPDM E/R (INTELLIGENT POWER DISTRIBUTION MODULE ENGINE ROOM)
Connector Color	BROWN

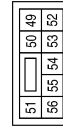

Terminal No.	Color of Wire	Signal Name
50	L	O LIGHT LBEAM LH
53	GR	LI LED DETECTION 2
54	LG	O LIGHT HBEAM RH

Connector No.	E201
Connector Name	WIRE TO WIRE
Connector Color	WHITE



Terminal No.	Color of Wire	Signal Name
2	B	-
3	B	-

AALIA2985GB

A
B
C
D
E
F
G
H
I
J
K
L
M
N
O
P

EXL

HEADLAMP

< WIRING DIAGRAM >

[LED HEADLAMP]

Connector No.	E239
Connector Name	FRONT COMBINATION LAMP LH
Connector Color	BLACK

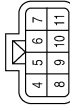

Terminal No.	Color of Wire	Signal Name
4	B	-
5	G	-
6	L	-
7	GR	-

Connector No.	E240
Connector Name	FRONT COMBINATION LAMP RH
Connector Color	BLACK

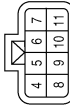

Terminal No.	Color of Wire	Signal Name
4	B	-
5	LG	-
6	SB	-
7	Y	-

Connector No.	B16
Connector Name	BCM (BODY CONTROL MODULE)
Connector Color	GREEN

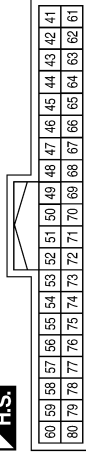

Terminal No.	Color of Wire	Signal Name
60	L	CAN-H
80	P	CAN-L

Connector No.	B41
Connector Name	WIRE TO WIRE
Connector Color	WHITE

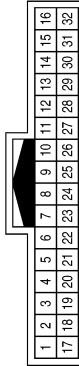

Terminal No.	Color of Wire	Signal Name
24	P	-
25	L	-

Connector No.	B63
Connector Name	JOINT CONNECTOR-B01
Connector Color	GRAY

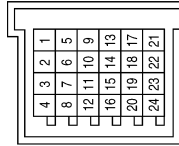

Terminal No.	Color of Wire	Signal Name
3	P	-
4	L	-
7	P	-
8	L	-

DAYTIME RUNNING LIGHT SYSTEM

< WIRING DIAGRAM >

[LED HEADLAMP]

DAYTIME RUNNING LIGHT SYSTEM

Wiring Diagram

INFOID:000000011379508

DAYTIME RUNNING LIGHT SYSTEM

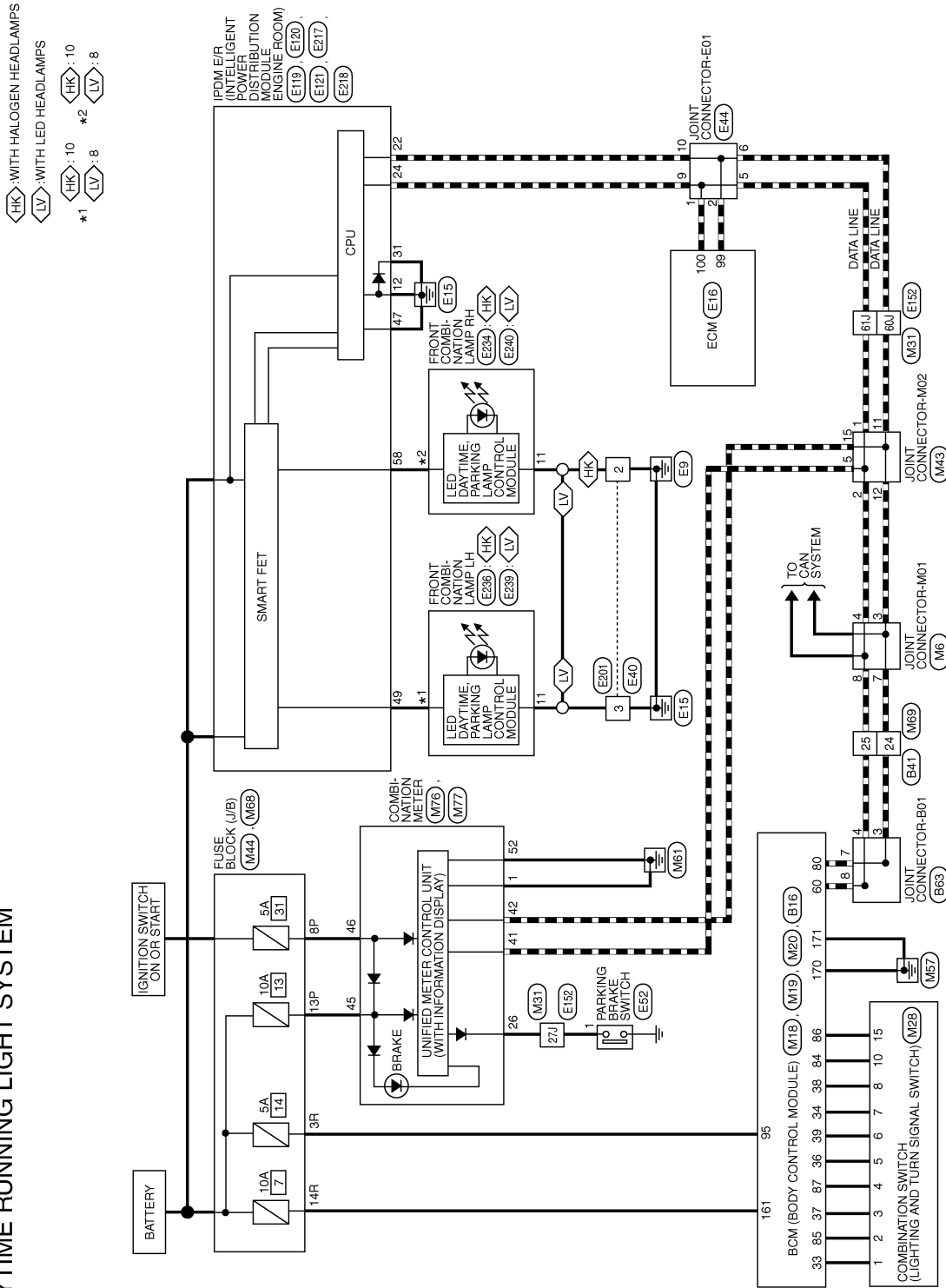

AALWA1045GB

A
B
C
D
E
F
G
H
I
J
K
L
M
N
O
P

EXL

DAYTIME RUNNING LIGHT SYSTEM

< WIRING DIAGRAM >

[LED HEADLAMP]

DAYTIME RUNNING LIGHT SYSTEM CONNECTORS

Connector No.	M6
Connector Name	JOINT CONNECTOR-M01
Connector Color	GRAY

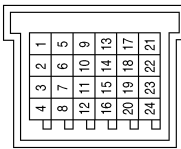

Terminal No.	Color of Wire	Signal Name
3	P	-
4	L	-
7	P	-
8	L	-

Connector No.	M18
Connector Name	BCM (BODY CONTROL MODULE)
Connector Color	GRAY

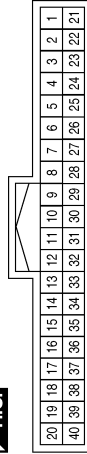

Terminal No.	Color of Wire	Signal Name
33	LG	I CSW 5
34	Y	O CSW 5
36	G	I CSW 3
37	GR	I CSW 4
38	V	I CSW 1
39	W	I CSW 2

Connector No.	M19
Connector Name	BCM (BODY CONTROL MODULE)
Connector Color	BLACK

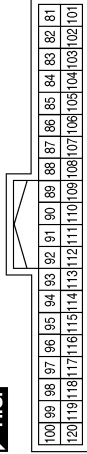

Terminal No.	Color of Wire	Signal Name
84	BR	O CSW 2
85	SB	O CSW 1
86	P	O CSW 3
87	BG	O CSW 4
95	V	I SHORTING PIN

Connector No.	M20
Connector Name	BCM (BODY CONTROL MODULE)
Connector Color	BROWN



Terminal No.	Color of Wire	Signal Name
161	W	I PWR ECU
170	B	I GND1
171	B	I GND2

Connector No.	M28
Connector Name	COMBINATION SWITCH (LIGHTING AND TURN SIGNAL SWITCH)
Connector Color	WHITE

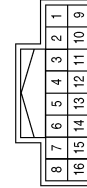

Terminal No.	Color of Wire	Signal Name
1	LG	-
2	SB	-
3	GR	-
4	BG	-

Terminal No.	Color of Wire	Signal Name
5	G	-
6	W	-
7	Y	-
8	V	-
10	BR	-
15	P	-

DAYTIME RUNNING LIGHT SYSTEM

< WIRING DIAGRAM >

[LED HEADLAMP]

Connector No.	M31
Connector Name	WIRE TO WIRE
Connector Color	WHITE

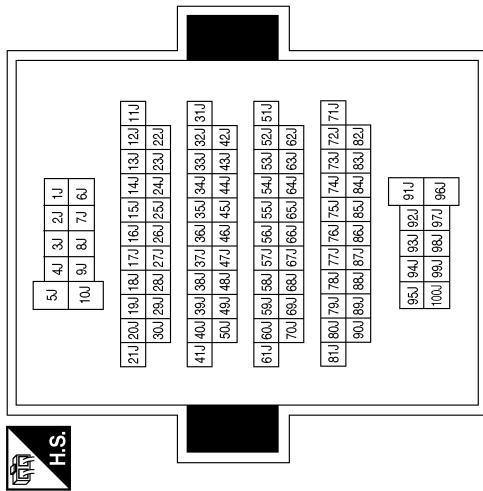

Connector No.	M43
Connector Name	JOINT CONNECTOR-M02
Connector Color	BLUE

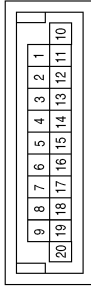

Terminal No.	Color of Wire	Signal Name
1	L	-
2	L	-
5	L	-
11	P	-
12	P	-
15	P	-

Connector No.	M44
Connector Name	FUSE BLOCK (J/B)
Connector Color	WHITE



Terminal No.	Color of Wire	Signal Name
8P	LA/BR	-
13P	LA/G	-

Terminal No.	Color of Wire	Signal Name
27J	G	-
60J	P	-
61J	L	-

Connector No.	M68
Connector Name	FUSE BLOCK (J/B)
Connector Color	BROWN



Terminal No.	Color of Wire	Signal Name
3R	V	-
14R	W	-

Connector No.	M69
Connector Name	WIRE TO WIRE
Connector Color	WHITE

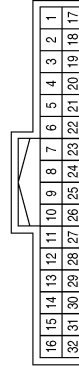

Terminal No.	Color of Wire	Signal Name
24	P	-
25	L	-

Connector No.	M76
Connector Name	COMBINATION METER
Connector Color	WHITE



Terminal No.	Color of Wire	Signal Name
1	B	GND
26	G	PBK SW

AALIA2954GB

A
B
C
D
E
F
G
H
I
J
K
EXL
M
N
O
P

DAYTIME RUNNING LIGHT SYSTEM

< WIRING DIAGRAM >

[LED HEADLAMP]

Connector No.	E40
Connector Name	WIRE TO WIRE
Connector Color	WHITE



Terminal No.	Color of Wire	Signal Name
2	GR	-
3	B	-

Connector No.	E16
Connector Name	ECM
Connector Color	BLACK

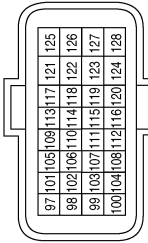

Terminal No.	Color of Wire	Signal Name
99	P	CAN-L
100	L	CAN-H

Connector No.	M77
Connector Name	COMBINATION METER
Connector Color	WHITE

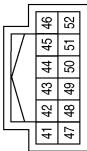

Terminal No.	Color of Wire	Signal Name
41	L	CAN-H
42	P	CAN-L
45	LA/G	BAT
46	LA/BR	IGN
52	B	G1

Connector No.	E119
Connector Name	IPDM E/R (INTELLIGENT POWER DISTRIBUTION MODULE ENGINE ROOM)
Connector Color	GRAY

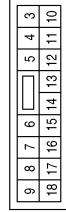

Connector No.	E52
Connector Name	PARKING BRAKE SWITCH
Connector Color	BLACK



Terminal No.	Color of Wire	Signal Name
12	B	SIGNAL GROUND

Connector No.	E44
Connector Name	JOINT CONNECTOR-E01
Connector Color	WHITE

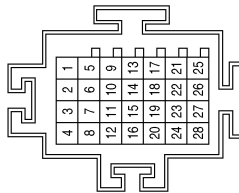

Terminal No.	Color of Wire	Signal Name
1	L	-
2	P	-
5	L	-
6	P	-
9	L	-
10	P	-

AALIA2955GB

DAYTIME RUNNING LIGHT SYSTEM

< WIRING DIAGRAM >

[LED HEADLAMP]

Connector No.	E121
Connector Name	IPDM E/R (INTELLIGENT POWER DISTRIBUTION MODULE ENGINE ROOM)
Connector Color	RED



Terminal No.	Color of Wire	Signal Name
47	B	POWER GROUND

Connector No.	E120
Connector Name	IPDM E/R (INTELLIGENT POWER DISTRIBUTION MODULE ENGINE ROOM)
Connector Color	GRAY

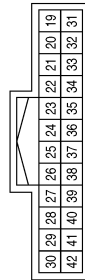

Terminal No.	Color of Wire	Signal Name
22	P	CAN-L
24	L	CAN-H
31	B	2ND SIGNAL GROUND

Connector No.	E201
Connector Name	WIRE TO WIRE
Connector Color	WHITE



Terminal No.	Color of Wire	Signal Name
2	B	-
3	B	-

Terminal No.	Color of Wire	Signal Name
27J	G	-
60J	P	-
61J	L	-

Connector No.	E152
Connector Name	WIRE TO WIRE
Connector Color	WHITE

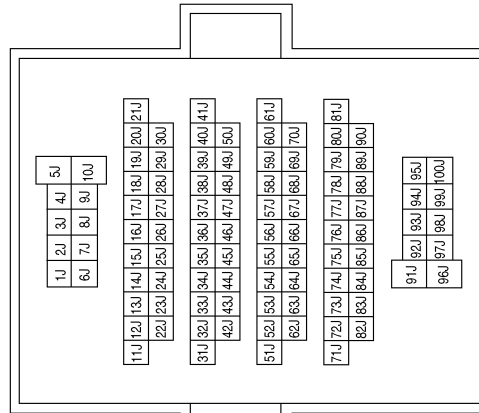

AALIA2956GB

A
B
C
D
E
F
G
H
I
J
K
EXL
M
N
O
P

DAYTIME RUNNING LIGHT SYSTEM

< WIRING DIAGRAM >

[LED HEADLAMP]

Connector No.	E234
Connector Name	FRONT COMBINATION LAMP RH (WITH HALOGEN HEADLAMPS)
Connector Color	GRAY



Terminal No.	Color of Wire	Signal Name
10	R	-
11	GR	-

Connector No.	E218
Connector Name	IPDM E/R (INTELLIGENT POWER DISTRIBUTION MODULE ENGINE ROOM)
Connector Color	WHITE

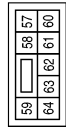

Terminal No.	Color of Wire	Signal Name
58	R	O LIGHT DTRL RH

Connector No.	E217
Connector Name	IPDM E/R (INTELLIGENT POWER DISTRIBUTION MODULE ENGINE ROOM)
Connector Color	BROWN



Terminal No.	Color of Wire	Signal Name
49	R	O LIGHT DTRL LH

Connector No.	E240
Connector Name	FRONT COMBINATION LAMP RH (WITH LED HEADLAMPS)
Connector Color	BLACK

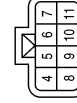

Terminal No.	Color of Wire	Signal Name
8	R	-
11	B	-

Connector No.	E239
Connector Name	FRONT COMBINATION LAMP LH (WITH LED HEADLAMPS)
Connector Color	BLACK

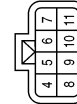

Terminal No.	Color of Wire	Signal Name
8	R	-
11	B	-

Connector No.	E236
Connector Name	FRONT COMBINATION LAMP LH (WITH HALOGEN HEADLAMPS)
Connector Color	GRAY



Terminal No.	Color of Wire	Signal Name
10	R	-
11	GR	-

AALIA21256B

DAYTIME RUNNING LIGHT SYSTEM

< WIRING DIAGRAM >

[LED HEADLAMP]

Connector No.	B63
Connector Name	JOINT CONNECTOR-B01
Connector Color	GRAY

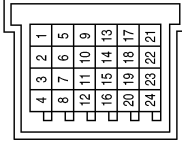

Terminal No.	Color of Wire	Signal Name
3	P	-
4	L	-
7	P	-
8	L	-

Connector No.	B41
Connector Name	WIRE TO WIRE
Connector Color	WHITE

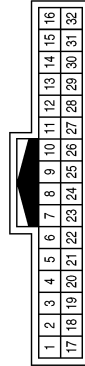

Terminal No.	Color of Wire	Signal Name
24	P	-
25	L	-

Connector No.	B16
Connector Name	BCM (BODY CONTROL MODULE)
Connector Color	GREEN

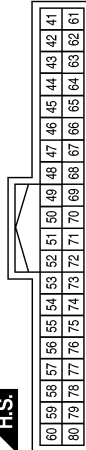

Terminal No.	Color of Wire	Signal Name
60	L	CAN-H
80	P	CAN-L

A
B
C
D
E
F
G
H
I
J
K
EXL
M
N
O
P

AUTO LIGHT SYSTEM

[LED HEADLAMP]

< WIRING DIAGRAM >

AUTO LIGHT SYSTEM

Wiring Diagram

INFOID:000000011379509

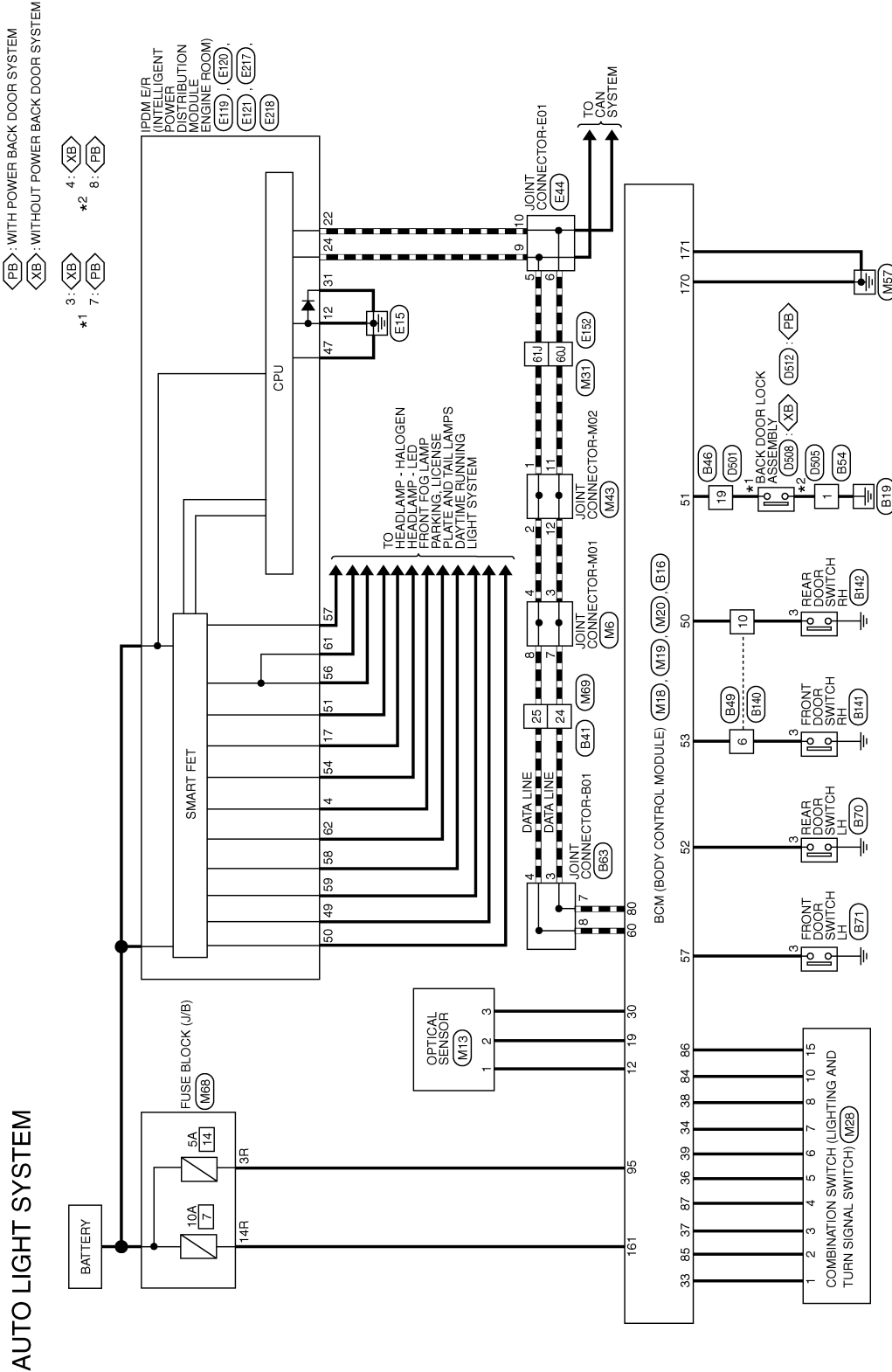

AALWA1043GB

AUTO LIGHT SYSTEM

< WIRING DIAGRAM >

[LED HEADLAMP]

AUTO LIGHT SYSTEM CONNECTORS

Connector No.	M6
Connector Name	JOINT CONNECTOR-M01
Connector Color	GRAY

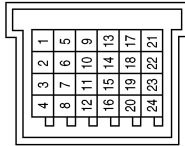

Terminal No.	Color of Wire	Signal Name
3	P	-
4	L	-
7	P	-
8	L	-

Connector No.	M13
Connector Name	OPTICAL SENSOR
Connector Color	WHITE



Terminal No.	Color of Wire	Signal Name
1	W	-
2	LG	-
3	V	-

Connector No.	M18
Connector Name	BCM (BODY CONTROL MODULE)
Connector Color	GRAY

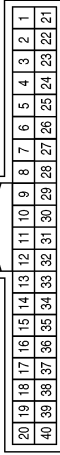

Terminal No.	Color of Wire	Signal Name
12	W	O PWR AUTOLIGHT SENSOR
19	LG	I AUTOLIGHT SENSOR
30	V	O GND AUTOLIGHT SENSOR
33	LG	I CSW 5
34	Y	O CSW 5
36	G	I CSW 3
37	GR	I CSW 4
38	V	I CSW 1
39	W	I CSW 2

Connector No.	M19
Connector Name	BCM (BODY CONTROL MODULE)
Connector Color	BLACK

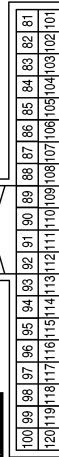

Terminal No.	Color of Wire	Signal Name
84	BR	O CSW 2
85	SB	O CSW 1
86	P	O CSW 3
87	BG	O CSW 4
95	V	I SHORTING PIN

Connector No.	M20
Connector Name	BCM (BODY CONTROL MODULE)
Connector Color	BROWN



Terminal No.	Color of Wire	Signal Name
161	W	I PWR ECU
170	B	I GND1
171	B	I GND2

AALIA2112GB

A
B
C
D
E
F
G
H
I
J
K
L
M
N
O
P

EXL

AUTO LIGHT SYSTEM

< WIRING DIAGRAM >

[LED HEADLAMP]

Connector No.	M43
Connector Name	JOINT CONNECTOR-M02
Connector Color	BLUE

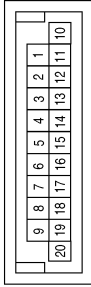

Terminal No.	Color of Wire	Signal Name
1	L	-
2	L	-
11	P	-
12	P	-

Connector No.	M31
Connector Name	WIRE TO WIRE
Connector Color	WHITE

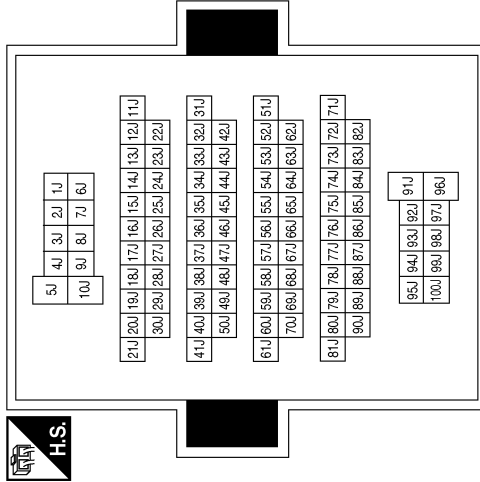

Terminal No.	Color of Wire	Signal Name
60J	P	-
61J	L	-

Connector No.	M28
Connector Name	COMBINATION SWITCH (LIGHTING AND TURN SIGNAL SWITCH)
Connector Color	WHITE

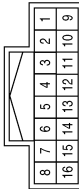

Terminal No.	Color of Wire	Signal Name
1	LG	-
2	SB	-
3	GR	-
4	BG	-
5	G	-
6	W	-
7	Y	-
8	V	-
10	BR	-
15	P	-

Connector No.	M68
Connector Name	FUSE BLOCK (J/B)
Connector Color	BROWN



Terminal No.	Color of Wire	Signal Name
3R	V	-
14R	W	-

Connector No.	M69
Connector Name	WIRE TO WIRE
Connector Color	WHITE

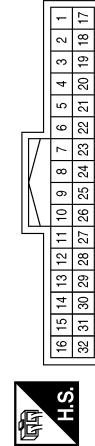

Terminal No.	Color of Wire	Signal Name
24	P	-
25	L	-

AUTO LIGHT SYSTEM

< WIRING DIAGRAM >

[LED HEADLAMP]

Connector No.	E120
Connector Name	IPDM E/R (INTELLIGENT POWER DISTRIBUTION MODULE ENGINE ROOM)
Connector Color	GRAY

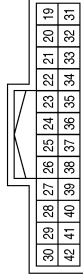

Terminal No.	Color of Wire	Signal Name
22	P	CAN-L
24	L	CAN-H
31	B	2ND SIGNAL GROUND

Connector No.	E119
Connector Name	IPDM E/R (INTELLIGENT POWER DISTRIBUTION MODULE ENGINE ROOM)
Connector Color	GRAY

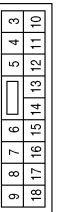

Terminal No.	Color of Wire	Signal Name
4	Y	O LIGHT POSITION REAR LH
12	B	SIGNAL GROUND
17	W	O LIGHT POSITION REAR RH

Connector No.	E44
Connector Name	JOINT CONNECTOR-E01
Connector Color	WHITE

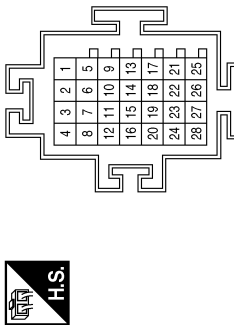

Terminal No.	Color of Wire	Signal Name
5	L	-
6	P	-
9	L	-
10	P	-

Connector No.	E152
Connector Name	WIRE TO WIRE
Connector Color	WHITE

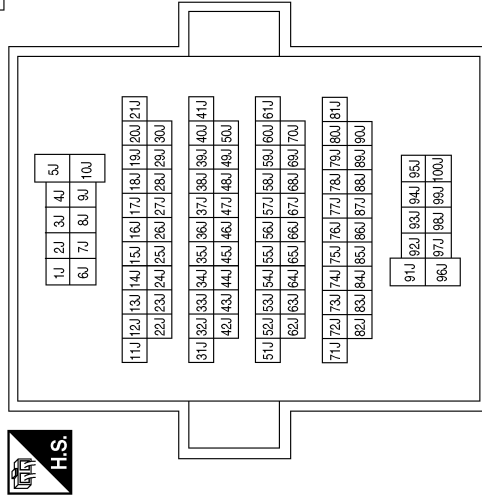

Connector No.	E121
Connector Name	IPDM E/R (INTELLIGENT POWER DISTRIBUTION MODULE ENGINE ROOM)
Connector Color	RED

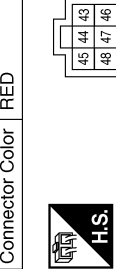

Terminal No.	Color of Wire	Signal Name
47	B	POWER GROUND

A
B
C
D
E
F
G
H
I
J
K
EXL
M
N
O
P

AUTO LIGHT SYSTEM

< WIRING DIAGRAM >

[LED HEADLAMP]

Connector No.	B16
Connector Name	BCM (BODY CONTROL MODULE)
Connector Color	GREEN

60	59	58	57	56	55	54	53	52	51	50	49	48	47	46	45	44	43	42	41	
80	79	78	77	76	75	74	73	72	71	70	69	68	67	66	65	64	63	62	61	

Terminal No.	Color of Wire	Signal Name
50	W	I RR DOOR SW
51	LG	I TGATE SW
52	R	I RL DOOR SW
53	SB	I AS DOOR2 SW
57	SB	I DR DOOR2 SW
60	L	CAN-H
80	P	CAN-L

Connector No.	E218
Connector Name	IPDM E/R (INTELLIGENT POWER DISTRIBUTION MODULE ENGINE ROOM)
Connector Color	WHITE

59	58	57	64	63	62	61	60
----	----	----	----	----	----	----	----

Terminal No.	Color of Wire	Signal Name
57	W	O LIGHT FR FOG LAMPS RH
58	R	O LIGHT DTRL RH
59	G	O LIGHT HBEAM LH
61	GR	O LIGHT CLEARANCE FR RH
62	SB	O LIGHT LBEAM RH

Connector No.	E217
Connector Name	IPDM E/R (INTELLIGENT POWER DISTRIBUTION MODULE ENGINE ROOM)
Connector Color	BROWN

51	50	49	56	55	54	53	52
----	----	----	----	----	----	----	----

Terminal No.	Color of Wire	Signal Name
49	R	O LIGHT DTRL LH
50	L	O LIGHT LBEAM LH
51	V	O LIGHT FR FOG LAMPS LH
54	LG	O LIGHT HBEAM RH
56	BG	O LIGHT CLEARANCE FR LH

Connector No.	B49
Connector Name	WIRE TO WIRE
Connector Color	WHITE

1	2	3	4	5	6	7	8	9	10	11	12
---	---	---	---	---	---	---	---	---	----	----	----

Terminal No.	Color of Wire	Signal Name
6	SB	—
10	W	—

Connector No.	B46
Connector Name	WIRE TO WIRE
Connector Color	WHITE

1	2	3	4	5	6	7	8	9	10	11	12	13	14	15	16
17	18	19	20	21	22	23	24	25	26	27	28	29	30	31	32

Terminal No.	Color of Wire	Signal Name
19	LG	—

Connector No.	B41
Connector Name	WIRE TO WIRE
Connector Color	WHITE

1	2	3	4	5	6	7	8	9	10	11	12	13	14	15	16
17	18	19	20	21	22	23	24	25	26	27	28	29	30	31	32

Terminal No.	Color of Wire	Signal Name
24	P	—
25	L	—

AALIA2115GB

AUTO LIGHT SYSTEM

< WIRING DIAGRAM >

[LED HEADLAMP]

Connector No.	B70
Connector Name	REAR DOOR SWITCH LH
Connector Color	WHITE

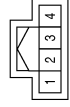

Terminal No.	Color of Wire	Signal Name
3	R	-

Connector No.	B63
Connector Name	JOINT CONNECTOR-B01
Connector Color	GRAY

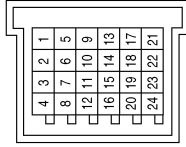

Terminal No.	Color of Wire	Signal Name
3	P	-
4	L	-
7	P	-
8	L	-

Connector No.	B54
Connector Name	WIRE TO WIRE
Connector Color	WHITE



Terminal No.	Color of Wire	Signal Name
1	B	-

Connector No.	B141
Connector Name	FRONT DOOR SWITCH RH
Connector Color	WHITE

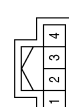

Terminal No.	Color of Wire	Signal Name
3	GR	-

Connector No.	B140
Connector Name	WIRE TO WIRE
Connector Color	WHITE

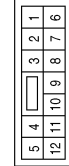

Terminal No.	Color of Wire	Signal Name
6	GR	-
10	W	-

Connector No.	B71
Connector Name	FRONT DOOR SWITCH LH
Connector Color	WHITE



Terminal No.	Color of Wire	Signal Name
3	SB	-

AALIA2116GB

A
B
C
D
E
F
G
H
I
J
K
EXL
M
N
O
P

AUTO LIGHT SYSTEM

< WIRING DIAGRAM >

[LED HEADLAMP]

Connector No.	D505
Connector Name	WIRE TO WIRE
Connector Color	WHITE



Terminal No.	Color of Wire	Signal Name
1	B	-

Connector No.	D501
Connector Name	WIRE TO WIRE
Connector Color	WHITE

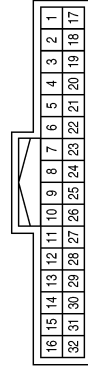

Terminal No.	Color of Wire	Signal Name
19	W	-

Connector No.	B142
Connector Name	REAR DOOR SWITCH RH
Connector Color	WHITE

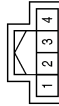

Terminal No.	Color of Wire	Signal Name
3	W	-

Connector No.	D512
Connector Name	BACK DOOR LOCK ASSEMBLY (WITH POWER BACK DOOR SYSTEM)
Connector Color	WHITE

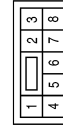

Terminal No.	Color of Wire	Signal Name
7	W	-
8	B	-

Connector No.	D508
Connector Name	BACK DOOR LOCK ASSEMBLY (WITHOUT POWER BACK DOOR SYSTEM)
Connector Color	WHITE



Terminal No.	Color of Wire	Signal Name
3	W	-
4	GR	-

AALIA2117GB

FRONT FOG LAMP SYSTEM

< WIRING DIAGRAM >

[LED HEADLAMP]

FRONT FOG LAMP SYSTEM

Wiring Diagram

INFOID:000000011379511

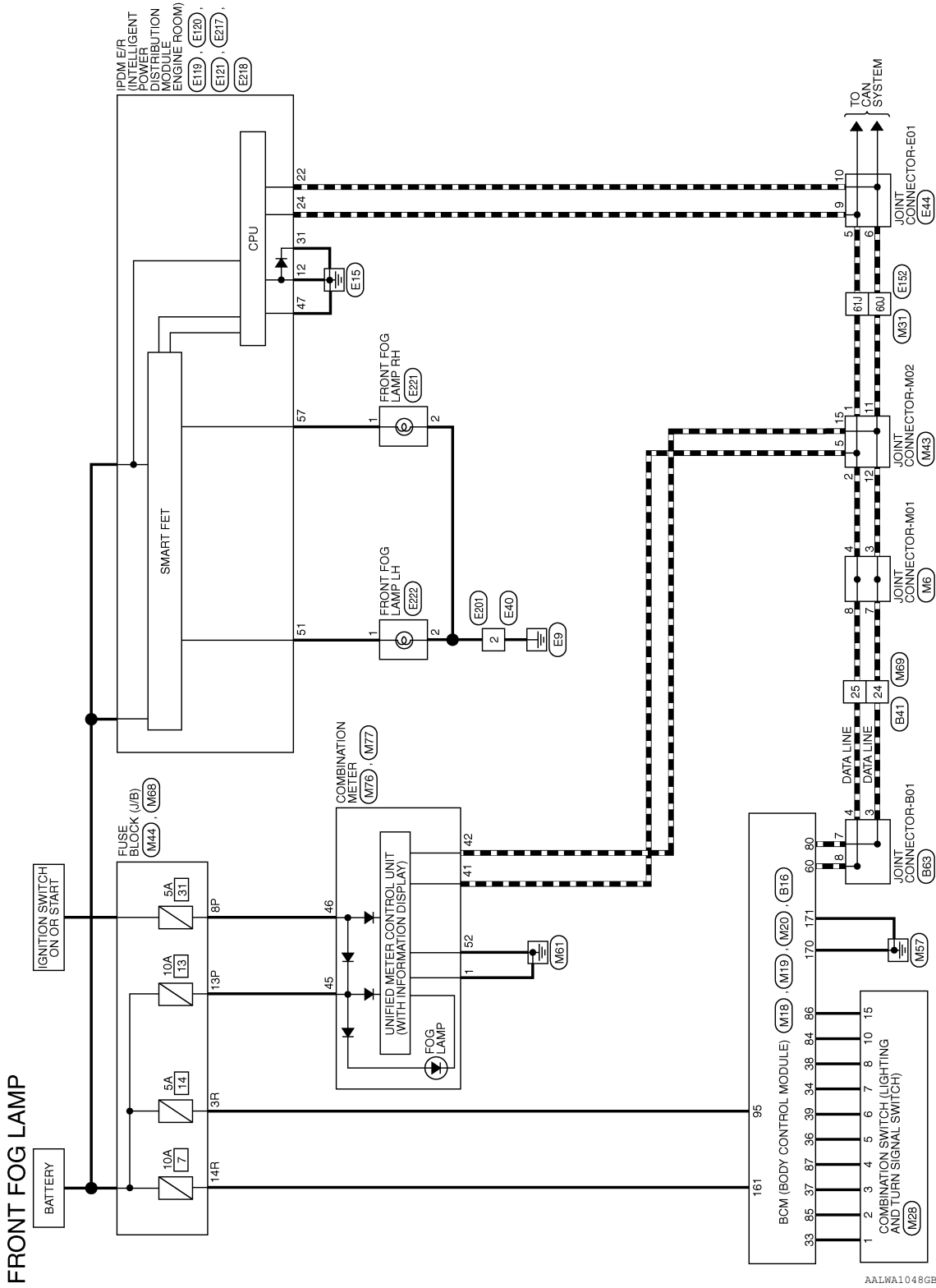

AALWA1048GB

A
B
C
D
E
F
G
H
I
J
K
EXL
M
N
O
P

FRONT FOG LAMP SYSTEM

< WIRING DIAGRAM >

[LED HEADLAMP]

FRONT FOG LAMP CONNECTORS

Connector No.	M6
Connector Name	JOINT CONNECTOR-M01
Connector Color	GRAY

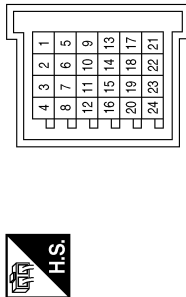

Terminal No.	Color of Wire	Signal Name
3	P	-
4	L	-
7	P	-
8	L	-

Connector No.	M18
Connector Name	BCM (BODY CONTROL MODULE)
Connector Color	GRAY

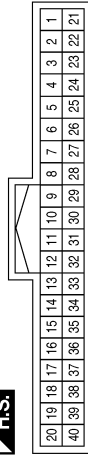

Terminal No.	Color of Wire	Signal Name
33	LG	I CSW 5
34	Y	O CSW 5
36	G	I CSW 3
37	GR	I CSW 4
38	V	I CSW 1
39	W	I CSW 2

Connector No.	M19
Connector Name	BCM (BODY CONTROL MODULE)
Connector Color	BLACK

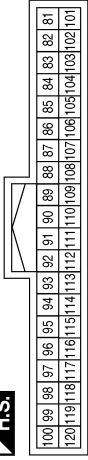

Terminal No.	Color of Wire	Signal Name
84	BR	O CSW 2
85	SB	O CSW 1
86	P	O CSW 3
87	BG	O CSW 4
95	V	I SHORTING PIN

Connector No.	M20
Connector Name	BCM (BODY CONTROL MODULE)
Connector Color	BROWN



Terminal No.	Color of Wire	Signal Name
161	W	I PWR ECU
170	B	I GND1
171	B	I GND2

Connector No.	M28
Connector Name	COMBINATION SWITCH (LIGHTING AND TURN SIGNAL SWITCH)
Connector Color	WHITE

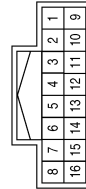

Terminal No.	Color of Wire	Signal Name
1	LG	-
2	SB	-
3	GR	-
4	BG	-
5	G	-

Terminal No.	Color of Wire	Signal Name
6	W	-
7	Y	-
8	V	-
10	BR	-
15	P	-

FRONT FOG LAMP SYSTEM

< WIRING DIAGRAM >

[LED HEADLAMP]

Connector No.	M43
Connector Name	JOINT CONNECTOR-M02
Connector Color	BLUE

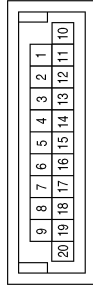

Terminal No.	Color of Wire	Signal Name
1	L	-
2	L	-
5	L	-
11	P	-
12	P	-
15	P	-

Terminal No.	Color of Wire	Signal Name
60J	P	-
61J	L	-

Connector No.	M31
Connector Name	WIRE TO WIRE
Connector Color	WHITE

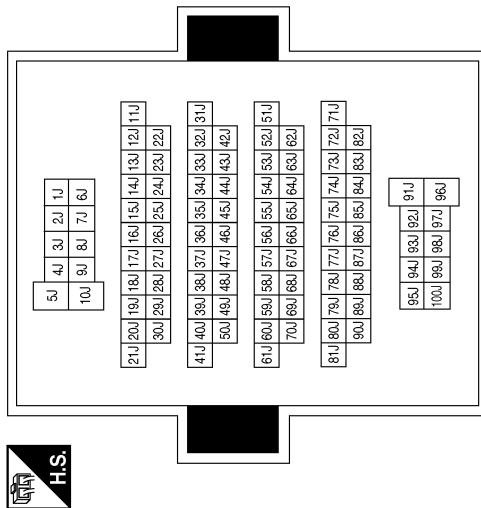

Connector No.	M69
Connector Name	WIRE TO WIRE
Connector Color	WHITE



Terminal No.	Color of Wire	Signal Name
24	P	-
25	L	-

Connector No.	M68
Connector Name	FUSE BLOCK (J/B)
Connector Color	BROWN



Terminal No.	Color of Wire	Signal Name
3R	V	-
14R	W	-

Connector No.	M44
Connector Name	FUSE BLOCK (J/B)
Connector Color	WHITE



Terminal No.	Color of Wire	Signal Name
8P	LA/BR	-
13P	LA/G	-

AALIA2967GB

A
B
C
D
E
F
G
H
I
J
K
EXL
M
N
O
P

FRONT FOG LAMP SYSTEM

< WIRING DIAGRAM >

[LED HEADLAMP]

Connector No.	E40
Connector Name	WIRE TO WIRE
Connector Color	WHITE



Terminal No.	Color of Wire	Signal Name
2	GR	-

Connector No.	M77
Connector Name	COMBINATION METER
Connector Color	WHITE

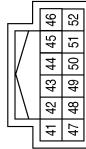

Terminal No.	Color of Wire	Signal Name
41	L	CAN-H
42	P	CAN-L
45	LA/G	BAT
46	LA/BR	IGN
52	B	G1

Connector No.	M76
Connector Name	COMBINATION METER
Connector Color	WHITE

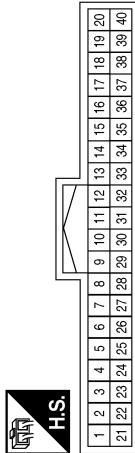

Terminal No.	Color of Wire	Signal Name
1	B	GND

Connector No.	E120
Connector Name	IPDM E/R (INTELLIGENT POWER DISTRIBUTION MODULE ENGINE ROOM)
Connector Color	GRAY

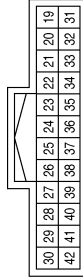

Connector No.	E119
Connector Name	IPDM E/R (INTELLIGENT POWER DISTRIBUTION MODULE ENGINE ROOM)
Connector Color	GRAY

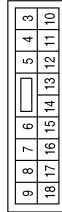

Connector No.	E44
Connector Name	JOINT CONNECTOR-E01
Connector Color	WHITE

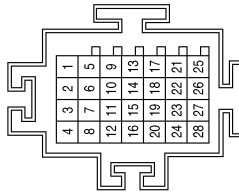

Terminal No.	Color of Wire	Signal Name
22	P	CAN-L
24	L	CAN-H
31	B	2ND SIGNAL GROUND

Terminal No.	Color of Wire	Signal Name
12	B	SIGNAL GROUND

Terminal No.	Color of Wire	Signal Name
5	L	-
6	P	-
9	L	-
10	P	-

AALIA2968GB

FRONT FOG LAMP SYSTEM

< WIRING DIAGRAM >

[LED HEADLAMP]

Terminal No.	Color of Wire	Signal Name
60J	P	-
61J	L	-

Connector No.	E152
Connector Name	WIRE TO WIRE
Connector Color	WHITE

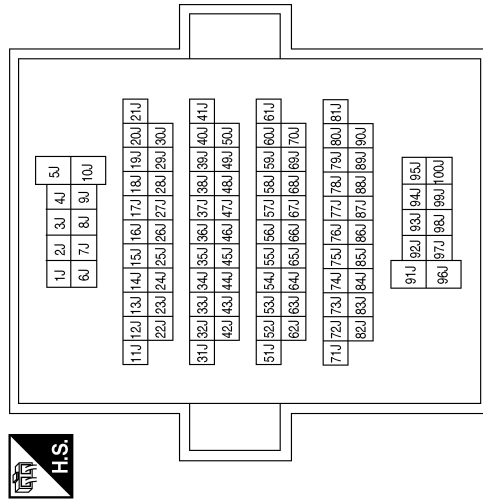

Connector No.	E121
Connector Name	IPDM E/R (INTELLIGENT POWER DISTRIBUTION MODULE ENGINE ROOM)
Connector Color	RED



Terminal No.	Color of Wire	Signal Name
47	B	POWER GROUND

Connector No.	E218
Connector Name	IPDM E/R (INTELLIGENT POWER DISTRIBUTION MODULE ENGINE ROOM)
Connector Color	WHITE



Terminal No.	Color of Wire	Signal Name
57	W	O LIGHT FR FOG LAMPS RH

Connector No.	E217
Connector Name	IPDM E/R (INTELLIGENT POWER DISTRIBUTION MODULE ENGINE ROOM)
Connector Color	BROWN



Terminal No.	Color of Wire	Signal Name
51	V	O LIGHT FR FOG LAMPS LH

Connector No.	E201
Connector Name	WIRE TO WIRE
Connector Color	WHITE



Terminal No.	Color of Wire	Signal Name
2	B	-

AALIA2969GB

A
B
C
D
E
F
G
H
I
J
K
L
M
N
O
P

EXL

FRONT FOG LAMP SYSTEM

< WIRING DIAGRAM >

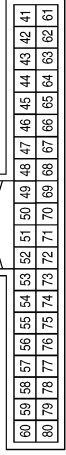

[LED HEADLAMP]

Connector No.	B16
Connector Name	BCM (BODY CONTROL MODULE)
Connector Color	GREEN



Terminal No.	Color of Wire	Signal Name
60	L	CAN-H
80	P	CAN-L

Connector No.	E222
Connector Name	FRONT FOG LAMP LH
Connector Color	BLACK

Terminal No.	Color of Wire	Signal Name
1	V	-
2	GR	-

Connector No.	E221
Connector Name	FRONT FOG LAMP RH
Connector Color	BLACK

Terminal No.	Color of Wire	Signal Name
1	W	-
2	GR	-

Connector No.	B63
Connector Name	JOINT CONNECTOR-B01
Connector Color	GRAY



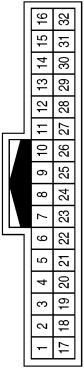

Terminal No.	Color of Wire	Signal Name
3	P	-
4	L	-
7	P	-
8	L	-

Connector No.	B41
Connector Name	WIRE TO WIRE
Connector Color	WHITE

Terminal No.	Color of Wire	Signal Name
24	P	-
25	L	-

Connector No.	B63
Connector Name	JOINT CONNECTOR-B01
Connector Color	GRAY

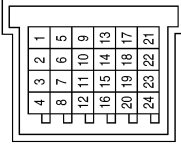
Terminal No.	Color of Wire	Signal Name
3	P	-
4	L	-
7	P	-
8	L	-

AALIA2131GB

TURN SIGNAL AND HAZARD WARNING LAMP SYSTEM

< WIRING DIAGRAM >

[LED HEADLAMP]

TURN SIGNAL AND HAZARD WARNING LAMP SYSTEM

Wiring Diagram

INFOID:000000011379512

TURN SIGNAL AND HAZARD WARNING LAMPS

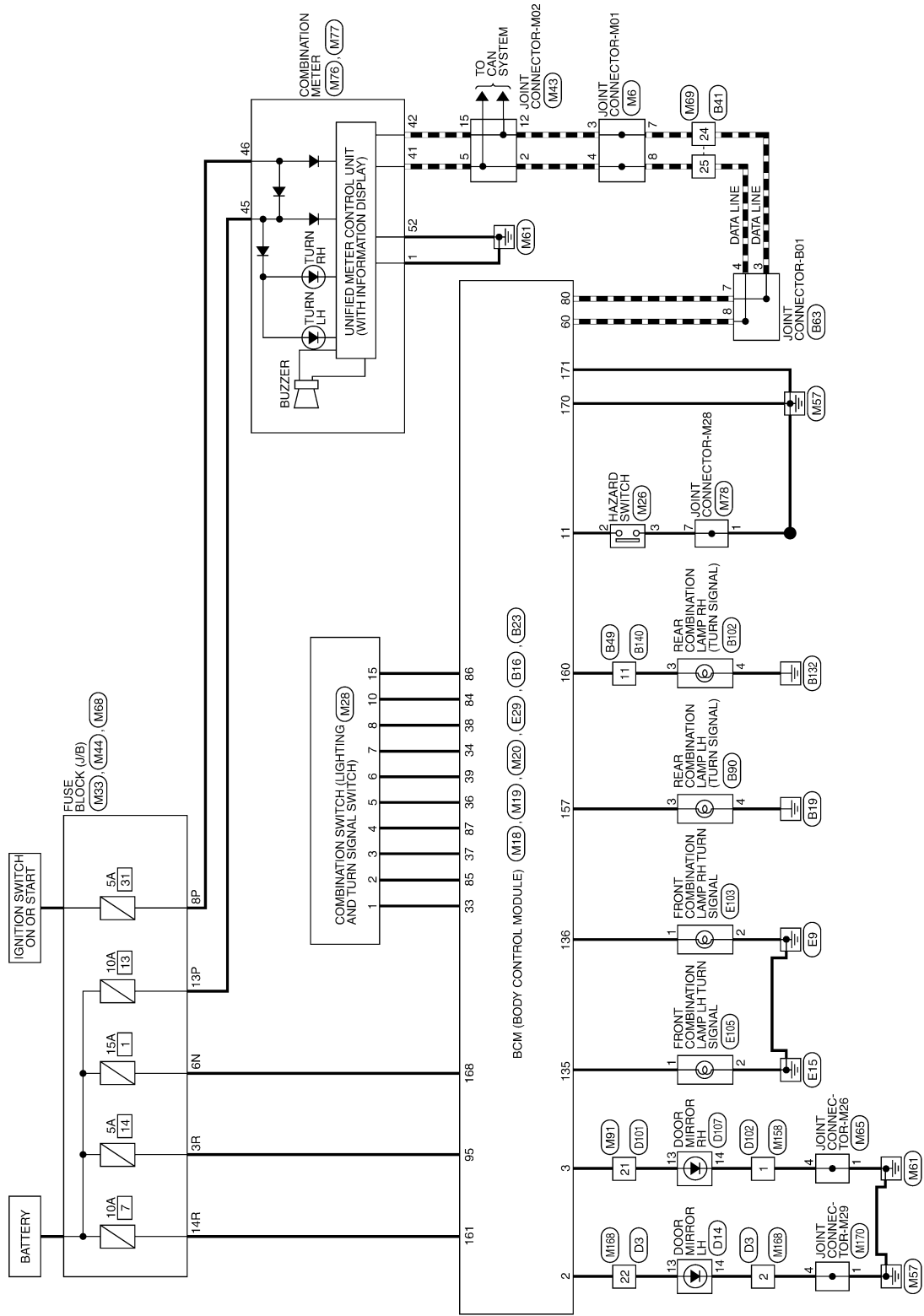

AALWA1041GB

A
B
C
D
E
F
G
H
I
J
K
EXL
M
N
O
P

TURN SIGNAL AND HAZARD WARNING LAMP SYSTEM

< WIRING DIAGRAM >

[LED HEADLAMP]

TURN SIGNAL AND HAZARD WARNING LAMPS CONNECTORS

Connector No.	M6
Connector Name	JOINT CONNECTOR-M01
Connector Color	GRAY

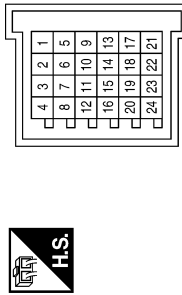

Terminal No.	Color of Wire	Signal Name
3	P	-
4	L	-
7	P	-
8	L	-

Connector No.	M18
Connector Name	BCM (BODY CONTROL MODULE)
Connector Color	GRAY

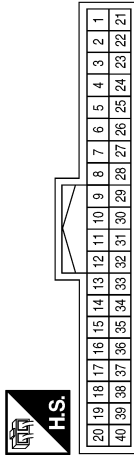

Terminal No.	Color of Wire	Signal Name
2	LA/G	O DI FR LEFT D
3	LAY	O DI FR RIGHT D
11	Y	I HAZARD SW D
33	LG	I CSW 5
34	Y	O CSW 5
36	G	I CSW 3
37	GR	I CSW 4
38	V	I CSW 1
39	W	I CSW 2

Connector No.	M19
Connector Name	BCM (BODY CONTROL MODULE)
Connector Color	BLACK

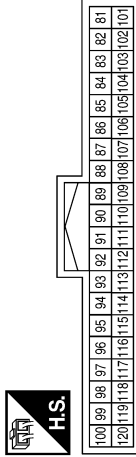

Terminal No.	Color of Wire	Signal Name
84	BR	O CSW 2
85	SB	O CSW 1
86	P	O CSW 3
87	BG	O CSW 4
95	V	I SHORTING PIN

Connector No.	M20
Connector Name	BCM (BODY CONTROL MODULE)
Connector Color	BROWN



Terminal No.	Color of Wire	Signal Name
161	W	I PWR ECU
168	BG	I PWR FLASHERS
170	B	I GND1
171	B	I GND2

Connector No.	M26
Connector Name	HAZARD SWITCH
Connector Color	WHITE



Terminal No.	Color of Wire	Signal Name
2	Y	-
3	GR	-

TURN SIGNAL AND HAZARD WARNING LAMP SYSTEM

< WIRING DIAGRAM >

[LED HEADLAMP]

Connector No.	M43
Connector Name	JOINT CONNECTOR-M02
Connector Color	BLUE

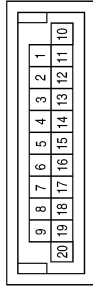

Terminal No.	Color of Wire	Signal Name
2	L	-
5	L	-
12	P	-
15	P	-

Connector No.	M33
Connector Name	FUSE BLOCK (J/B)
Connector Color	WHITE

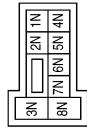

Terminal No.	Color of Wire	Signal Name
6N	BG	-

Connector No.	M28
Connector Name	COMBINATION SWITCH (LIGHTING AND TURN SIGNAL SWITCH)
Connector Color	WHITE

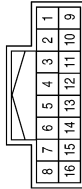

Terminal No.	Color of Wire	Signal Name
1	LG	-
2	SB	-
3	GR	-
4	BG	-
5	G	-
6	W	-
7	Y	-
8	V	-
10	BR	-
15	P	-

Connector No.	M68
Connector Name	FUSE BLOCK (J/B)
Connector Color	BROWN



Terminal No.	Color of Wire	Signal Name
3R	V	-
14R	W	-

Connector No.	M65
Connector Name	JOINT CONNECTOR-M26
Connector Color	WHITE

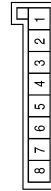

Terminal No.	Color of Wire	Signal Name
1	B	-
4	B	-

Connector No.	M44
Connector Name	FUSE BLOCK (J/B)
Connector Color	WHITE



Terminal No.	Color of Wire	Signal Name
8P	LA/BR	-
13P	LA/G	-

AALIA2950GB

A
B
C
D
E
F
G
H
I
J
K
L
M
N
O
P

EXL

TURN SIGNAL AND HAZARD WARNING LAMP SYSTEM

< WIRING DIAGRAM >

[LED HEADLAMP]

Connector No.	M77
Connector Name	COMBINATION METER
Connector Color	WHITE

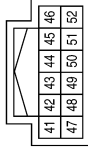

Terminal No.	Color of Wire	Signal Name
41	L	CAN-H
42	P	CAN-L
45	LA/G	BAT
46	LA/BR	IGN
52	B	G1

Connector No.	M76
Connector Name	COMBINATION METER
Connector Color	WHITE

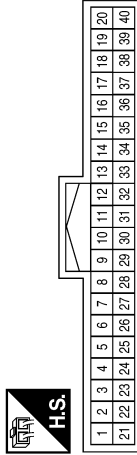

Terminal No.	Color of Wire	Signal Name
1	B	GND

Connector No.	M69
Connector Name	WIRE TO WIRE
Connector Color	WHITE

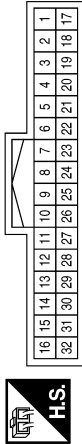

Terminal No.	Color of Wire	Signal Name
24	P	-
25	L	-

Connector No.	M158
Connector Name	WIRE TO WIRE
Connector Color	WHITE

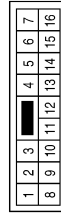

Terminal No.	Color of Wire	Signal Name
1	B	-

Connector No.	M91
Connector Name	WIRE TO WIRE
Connector Color	WHITE

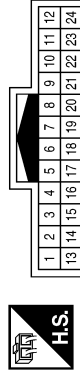

Terminal No.	Color of Wire	Signal Name
21	LAY	-

Connector No.	M78
Connector Name	JOINT CONNECTOR-M28
Connector Color	WHITE

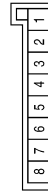

Terminal No.	Color of Wire	Signal Name
1	GR	-
7	GR	-

AALIA2980GB

TURN SIGNAL AND HAZARD WARNING LAMP SYSTEM

< WIRING DIAGRAM >

[LED HEADLAMP]

Connector No.	E29
Connector Name	BCM (BODY CONTROL MODULE)
Connector Color	BLACK

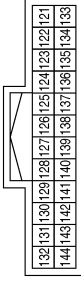

Terminal No.	Color of Wire	Signal Name
135	BR	DI FR LEFT E
136	GR	O DI FR RIGHT E

Connector No.	M170
Connector Name	JOINT CONNECTOR-M29
Connector Color	WHITE



Terminal No.	Color of Wire	Signal Name
1	B	-
4	B	-

Connector No.	M168
Connector Name	WIRE TO WIRE
Connector Color	WHITE

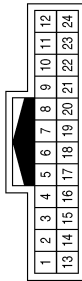

Terminal No.	Color of Wire	Signal Name
2	B	-
22	LA/G	-

Connector No.	B16
Connector Name	BCM (BODY CONTROL MODULE)
Connector Color	GREEN

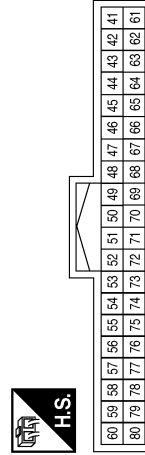

Terminal No.	Color of Wire	Signal Name
60	L	CAN-H
80	P	CAN-L

Connector No.	E105
Connector Name	FRONT COMBINATION LAMP LH
Connector Color	GRAY



Terminal No.	Color of Wire	Signal Name
1	BR	-
2	B	-

Connector No.	E103
Connector Name	FRONT COMBINATION LAMP RH
Connector Color	GRAY



Terminal No.	Color of Wire	Signal Name
1	GR	-
2	BR	-

AALIA2165GB

A
B
C
D
E
F
G
H
I
J
K
EXL
M
N
O
P

TURN SIGNAL AND HAZARD WARNING LAMP SYSTEM

< WIRING DIAGRAM >

[LED HEADLAMP]

Connector No.	B49
Connector Name	WIRE TO WIRE
Connector Color	WHITE

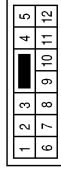

Terminal No.	Color of Wire	Signal Name
11	P	-

Connector No.	B41
Connector Name	WIRE TO WIRE
Connector Color	WHITE

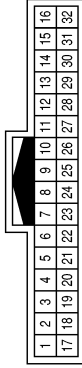

Terminal No.	Color of Wire	Signal Name
24	P	-
25	L	-

Connector No.	B23
Connector Name	BCM (BODY CONTROL MODULE)
Connector Color	GRAY



Terminal No.	Color of Wire	Signal Name
157	GR	O D I RR LEFT B
160	P	O D I RR RIGHT B

Connector No.	B102
Connector Name	REAR COMBINATION LAMP RH
Connector Color	WHITE



Terminal No.	Color of Wire	Signal Name
3	LA/V	-
4	B	-

Connector No.	B90
Connector Name	REAR COMBINATION LAMP LH
Connector Color	WHITE



Terminal No.	Color of Wire	Signal Name
3	GR	-
4	B	-

Connector No.	B63
Connector Name	JOINT CONNECTOR-B01
Connector Color	GRAY

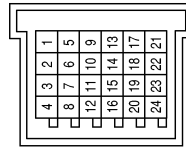

Terminal No.	Color of Wire	Signal Name
3	P	-
4	L	-
7	P	-
8	L	-

AALIA2166GB

TURN SIGNAL AND HAZARD WARNING LAMP SYSTEM

< WIRING DIAGRAM >

[LED HEADLAMP]

Connector No.	D14
Connector Name	DOOR MIRROR LH
Connector Color	WHITE

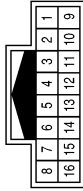

Terminal No.	Color of Wire	Signal Name
13	LA/G	-
14	LA/B	-

Connector No.	D3
Connector Name	WIRE TO WIRE
Connector Color	WHITE

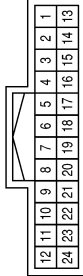

Terminal No.	Color of Wire	Signal Name
2	LA/B	-
22	LA/G	-

Connector No.	B140
Connector Name	WIRE TO WIRE
Connector Color	WHITE

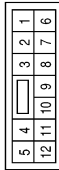

Terminal No.	Color of Wire	Signal Name
11	LAV	-

Connector No.	D107
Connector Name	DOOR MIRROR RH
Connector Color	WHITE



Terminal No.	Color of Wire	Signal Name
13	LA/G	-
14	LA/B	-

Connector No.	D102
Connector Name	WIRE TO WIRE
Connector Color	WHITE

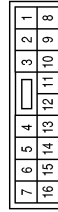

Terminal No.	Color of Wire	Signal Name
1	LA/B	-

Connector No.	D101
Connector Name	WIRE TO WIRE
Connector Color	WHITE

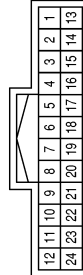

Terminal No.	Color of Wire	Signal Name
21	LA/G	-

AALIA2239GB

A
B
C
D
E
F
G
H
I
J
K
EXL
M
N
O
P

PARKING, LICENSE PLATE AND TAIL LAMPS SYSTEM

< WIRING DIAGRAM >

[LED HEADLAMP]

PARKING, LICENSE PLATE AND TAIL LAMPS SYSTEM

Wiring Diagram

INFOID:000000011379513

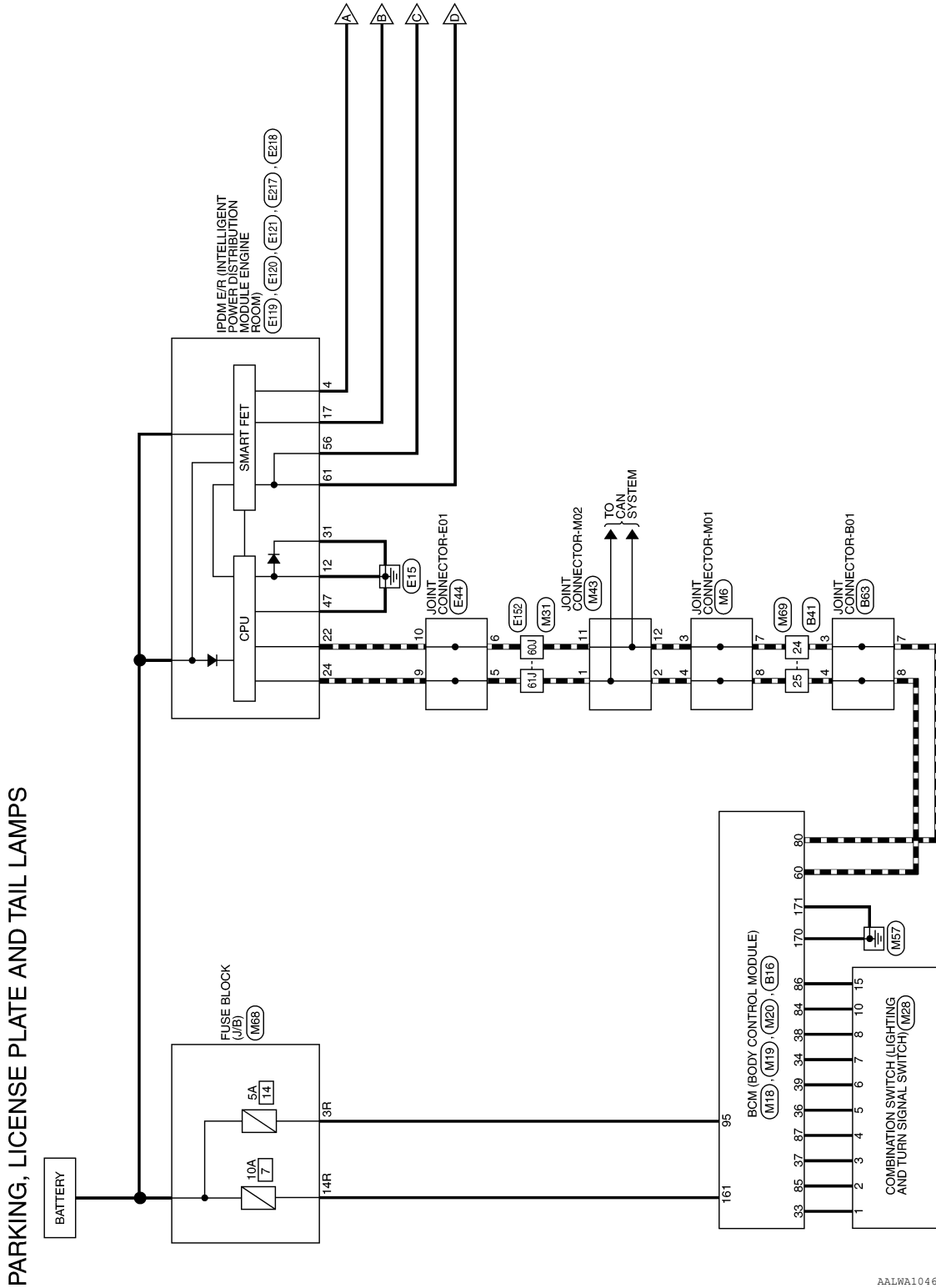

AALWA1046GB

PARKING, LICENSE PLATE AND TAIL LAMPS SYSTEM

< WIRING DIAGRAM >

[LED HEADLAMP]

(HK) : WITH HALOGEN HEADLAMPS
 (LV) : WITH LED HEADLAMPS
 (HK) : 12 *2
 (LV) : 9 *1

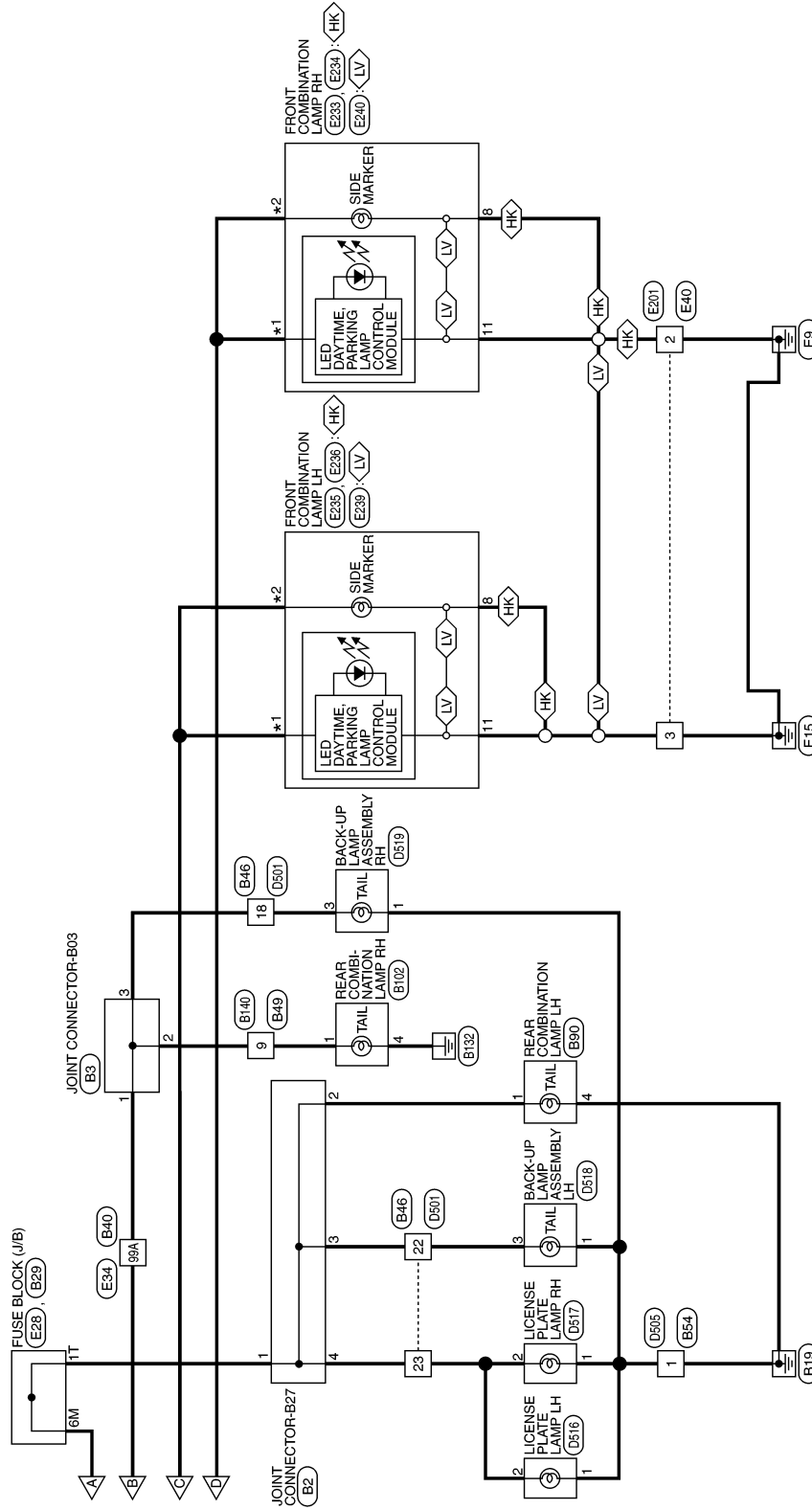

AALWA1047GB

A
B
C
D
E
F
G
H
I
J
K
EXL
M
N
O
P

PARKING, LICENSE PLATE AND TAIL LAMPS SYSTEM

< WIRING DIAGRAM >

[LED HEADLAMP]

PARKING, LICENSE AND TAIL LAMPS CONNECTORS

Connector No.	M6
Connector Name	JOINT CONNECTOR-M01
Connector Color	GRAY

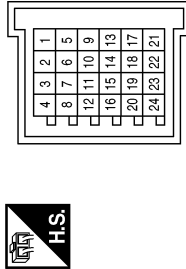

Terminal No.	Color of Wire	Signal Name
3	P	-
4	L	-
7	P	-
8	L	-

Connector No.	M18
Connector Name	BCM (BODY CONTROL MODULE)
Connector Color	GRAY

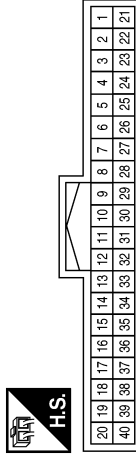

Terminal No.	Color of Wire	Signal Name
33	LG	I CSW 5
34	Y	O CSW 5
36	G	I CSW 3
37	GR	I CSW 4
38	V	I CSW 1
39	W	I CSW 2

Connector No.	M19
Connector Name	BCM (BODY CONTROL MODULE)
Connector Color	BLACK

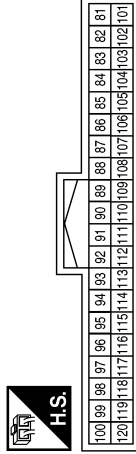

Terminal No.	Color of Wire	Signal Name
84	BR	O CSW 2
85	SB	O CSW 1
86	P	O CSW 3
87	BG	O CSW 4
95	V	I SHORTING PIN

Connector No.	M20
Connector Name	BCM (BODY CONTROL MODULE)
Connector Color	BROWN



Terminal No.	Color of Wire	Signal Name
161	W	I PWR ECU
170	B	I GND1
171	B	I GND2

Connector No.	M28
Connector Name	COMBINATION SWITCH (LIGHTING AND TURN SIGNAL SWITCH)
Connector Color	WHITE

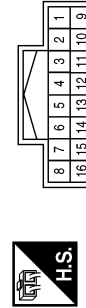

Terminal No.	Color of Wire	Signal Name
1	LG	-
2	SB	-
3	GR	-
4	BG	-

Terminal No.	Color of Wire	Signal Name
5	G	-
6	W	-
7	Y	-
8	V	-
10	BR	-
15	P	-

PARKING, LICENSE PLATE AND TAIL LAMPS SYSTEM

< WIRING DIAGRAM >

[LED HEADLAMP]

Connector No.	M43
Connector Name	JOINT CONNECTOR-M02
Connector Color	BLUE

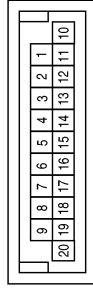

Terminal No.	Color of Wire	Signal Name
1	L	-
2	L	-
11	P	-
12	P	-

Terminal No.	Color of Wire	Signal Name
60J	P	-
61J	L	-

Connector No.	M31
Connector Name	WIRE TO WIRE
Connector Color	WHITE

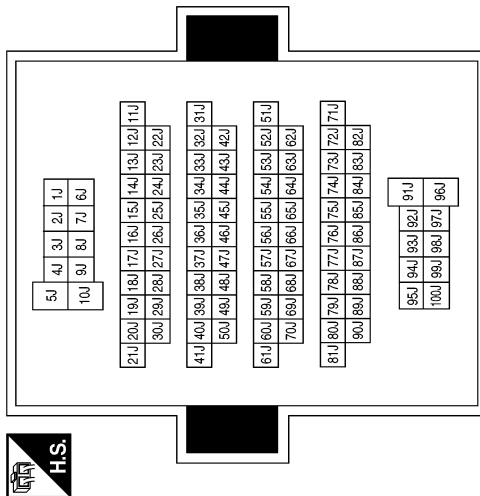

Connector No.	E28
Connector Name	FUSE BLOCK (J/B)
Connector Color	WHITE



Terminal No.	Color of Wire	Signal Name
6M	Y	-

Connector No.	M69
Connector Name	WIRE TO WIRE
Connector Color	WHITE



Terminal No.	Color of Wire	Signal Name
24	P	-
25	L	-

Connector No.	M68
Connector Name	FUSE BLOCK (J/B)
Connector Color	BROWN



Terminal No.	Color of Wire	Signal Name
3R	V	-
14R	W	-

AALIA2958GB

A
B
C
D
E
F
G
H
I
J
K
L
M
N
O
P

EXL

PARKING, LICENSE PLATE AND TAIL LAMPS SYSTEM

< WIRING DIAGRAM >

[LED HEADLAMP]

Connector No.	E40
Connector Name	WIRE TO WIRE
Connector Color	WHITE



Terminal No.	Color of Wire	Signal Name
2	GR	-
3	B	-

Terminal No.	99A	Color of Wire	W	Signal Name	-
--------------	-----	---------------	---	-------------	---

Connector No.	E34
Connector Name	WIRE TO WIRE
Connector Color	GRAY

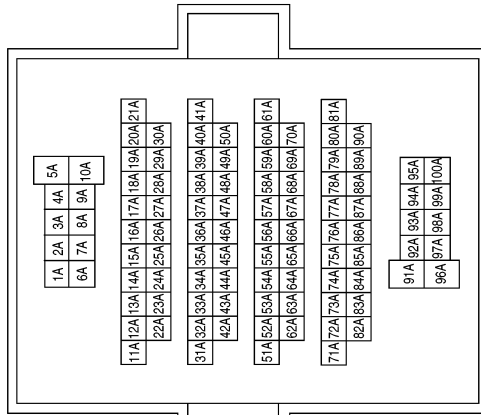

Connector No.	E119
Connector Name	IPDM E/R (INTELLIGENT POWER DISTRIBUTION MODULE ENGINE ROOM)
Connector Color	GRAY

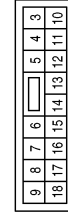

Terminal No.	Color of Wire	Signal Name
4	Y	O LIGHT POSITION REAR LH
12	B	SIGNAL GROUND
17	W	O LIGHT POSITION REAR RH

Terminal No.	5	Color of Wire	L	Signal Name	-
	6	Color of Wire	P	Signal Name	-
	9	Color of Wire	L	Signal Name	-
	10	Color of Wire	P	Signal Name	-

Connector No.	E44
Connector Name	JOINT CONNECTOR-E01
Connector Color	WHITE

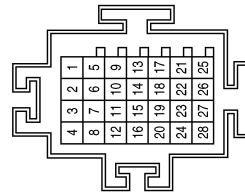

AALIA2959GB

PARKING, LICENSE PLATE AND TAIL LAMPS SYSTEM

< WIRING DIAGRAM >

[LED HEADLAMP]

Connector No.	E121
Connector Name	IPDM E/R (INTELLIGENT POWER DISTRIBUTION MODULE ENGINE ROOM)
Connector Color	RED



Terminal No.	Color of Wire	Signal Name
47	B	POWER GROUND

Connector No.	E120
Connector Name	IPDM E/R (INTELLIGENT POWER DISTRIBUTION MODULE ENGINE ROOM)
Connector Color	GRAY

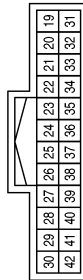

Terminal No.	Color of Wire	Signal Name
22	P	CAN-L
24	L	CAN-H
31	B	2ND SIGNAL GROUND

Connector No.	E201
Connector Name	WIRE TO WIRE
Connector Color	WHITE



Terminal No.	Color of Wire	Signal Name
2	B	-
3	B	-

Terminal No.	Color of Wire	Signal Name
60J	P	-
61J	L	-

Connector No.	E152
Connector Name	WIRE TO WIRE
Connector Color	WHITE

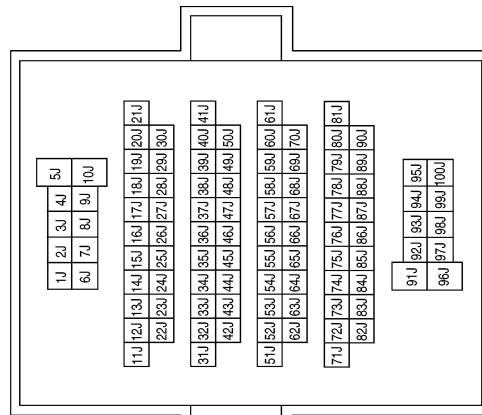

AALIA2960GB

A
B
C
D
E
F
G
H
I
J
K
EXL
M
N
O
P

PARKING, LICENSE PLATE AND TAIL LAMPS SYSTEM

< WIRING DIAGRAM >

[LED HEADLAMP]

Connector No.	E233
Connector Name	FRONT COMBINATION LAMP RH (WITH HALOGEN HEADLAMPS)
Connector Color	BLACK



Terminal No.	Color of Wire	Signal Name
8	B	-
9	W	-

Connector No.	E218
Connector Name	IPDM E/R (INTELLIGENT POWER DISTRIBUTION MODULE ENGINE ROOM)
Connector Color	WHITE

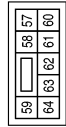

Terminal No.	Color of Wire	Signal Name
61	GR	O LIGHT CLEARANCE FR RH

Connector No.	E217
Connector Name	IPDM E/R (INTELLIGENT POWER DISTRIBUTION MODULE ENGINE ROOM)
Connector Color	BROWN

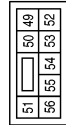

Terminal No.	Color of Wire	Signal Name
56	BG	O LIGHT CLEARANCE FR LH

Connector No.	E236
Connector Name	FRONT COMBINATION LAMP LH (WITH HALOGEN HEADLAMPS)
Connector Color	GRAY



Terminal No.	Color of Wire	Signal Name
11	GR	-
12	BG	-

Connector No.	E235
Connector Name	FRONT COMBINATION LAMP LH (WITH HALOGEN HEADLAMPS)
Connector Color	BLACK



Terminal No.	Color of Wire	Signal Name
8	B	-
9	P	-

Connector No.	E234
Connector Name	FRONT COMBINATION LAMP RH (WITH HALOGEN HEADLAMPS)
Connector Color	GRAY



Terminal No.	Color of Wire	Signal Name
11	GR	-
12	GR	-

AALIA2961GB

PARKING, LICENSE PLATE AND TAIL LAMPS SYSTEM

< WIRING DIAGRAM >

[LED HEADLAMP]

Connector No.	B2
Connector Name	JOINT CONNECTOR-B27
Connector Color	WHITE



Terminal No.	Color of Wire	Signal Name
1	LA/R	-
2	LA/R	-
3	LA/R	-
4	LA/R	-

Connector No.	E240
Connector Name	FRONT COMBINATION LAMP RH (WITH LED HEADLAMPS)
Connector Color	BLACK

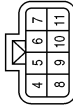

Terminal No.	Color of Wire	Signal Name
9	GR	-
10	W	-
11	B	-

Connector No.	E239
Connector Name	FRONT COMBINATION LAMP LH (WITH LED HEADLAMPS)
Connector Color	BLACK

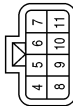

Terminal No.	Color of Wire	Signal Name
9	BG	-
10	P	-
11	B	-

Connector No.	B29
Connector Name	FUSE BLOCK (J/B)
Connector Color	WHITE

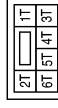

Terminal No.	Color of Wire	Signal Name
1T	LA/R	-

Connector No.	B16
Connector Name	BCM (BODY CONTROL MODULE)
Connector Color	GREEN

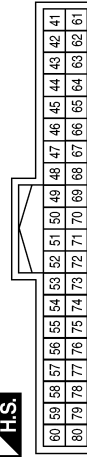

Terminal No.	Color of Wire	Signal Name
60	L	CAN-H
80	P	CAN-L

Connector No.	B3
Connector Name	JOINT CONNECTOR-B03
Connector Color	WHITE

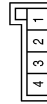

Terminal No.	Color of Wire	Signal Name
1	LA/BR	-
2	LA/BR	-
3	LA/BR	-

AALIA2962GB

A
B
C
D
E
F
G
H
I
J
K
L
M
N
O
P

EXL

PARKING, LICENSE PLATE AND TAIL LAMPS SYSTEM

< WIRING DIAGRAM >

[LED HEADLAMP]

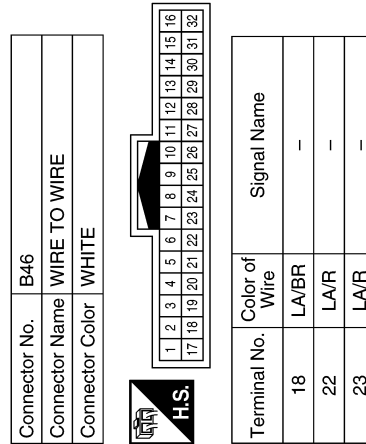
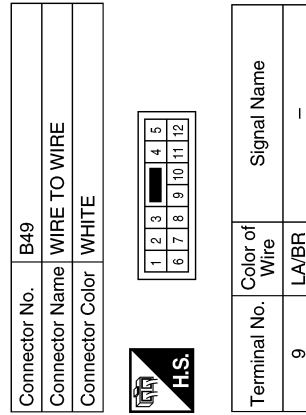
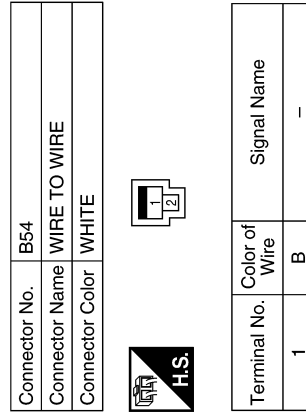
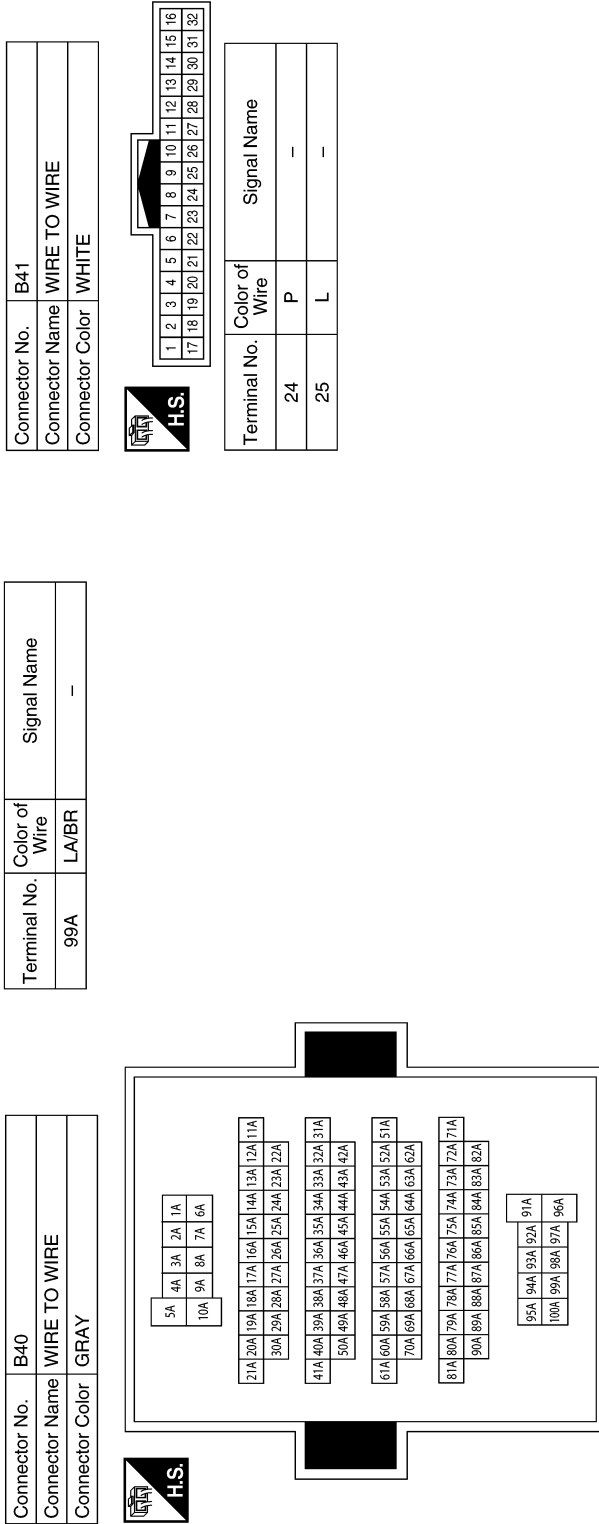

AALIA2963GB

PARKING, LICENSE PLATE AND TAIL LAMPS SYSTEM

< WIRING DIAGRAM >

[LED HEADLAMP]

Connector No.	B102
Connector Name	REAR COMBINATION LAMP RH
Connector Color	WHITE



Terminal No.	Color of Wire	Signal Name
1	LA/BR	-
4	B	-

Connector No.	B90
Connector Name	REAR COMBINATION LAMP LH
Connector Color	WHITE



Terminal No.	Color of Wire	Signal Name
1	LA/R	-
4	B	-

Connector No.	B63
Connector Name	JOINT CONNECTOR-B01
Connector Color	GRAY

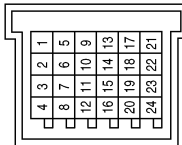

Terminal No.	Color of Wire	Signal Name
3	P	-
4	L	-
7	P	-
8	L	-

Connector No.	D505
Connector Name	WIRE TO WIRE
Connector Color	WHITE



Terminal No.	Color of Wire	Signal Name
1	B	-

Connector No.	D501
Connector Name	WIRE TO WIRE
Connector Color	WHITE



Terminal No.	Color of Wire	Signal Name
18	LA/R	-
22	LA/Y	-
23	P	-

Connector No.	B140
Connector Name	WIRE TO WIRE
Connector Color	WHITE



Terminal No.	Color of Wire	Signal Name
9	LA/BR	-

A
B
C
D
E
F
G
H
I
J
K
EXL
M
N
O
P

PARKING, LICENSE PLATE AND TAIL LAMPS SYSTEM

< WIRING DIAGRAM >

[LED HEADLAMP]

Connector No.	D518
Connector Name	BACK-UP LAMP ASSEMBLY LH
Connector Color	WHITE

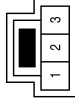

Terminal No.	Color of Wire	Signal Name
1	GR	-
3	LAVY	-

Connector No.	D517
Connector Name	LICENSE PLATE LAMP RH
Connector Color	BROWN



Terminal No.	Color of Wire	Signal Name
1	B	-
2	R	-

Connector No.	D516
Connector Name	LICENSE PLATE LAMP LH
Connector Color	BROWN



Terminal No.	Color of Wire	Signal Name
1	B	-
2	P	-

AALIA2978GB

STOP LAMP

< WIRING DIAGRAM >

[LED HEADLAMP]

STOP LAMP

Wiring Diagram

INFOID:0000000011379514

STOP LAMP

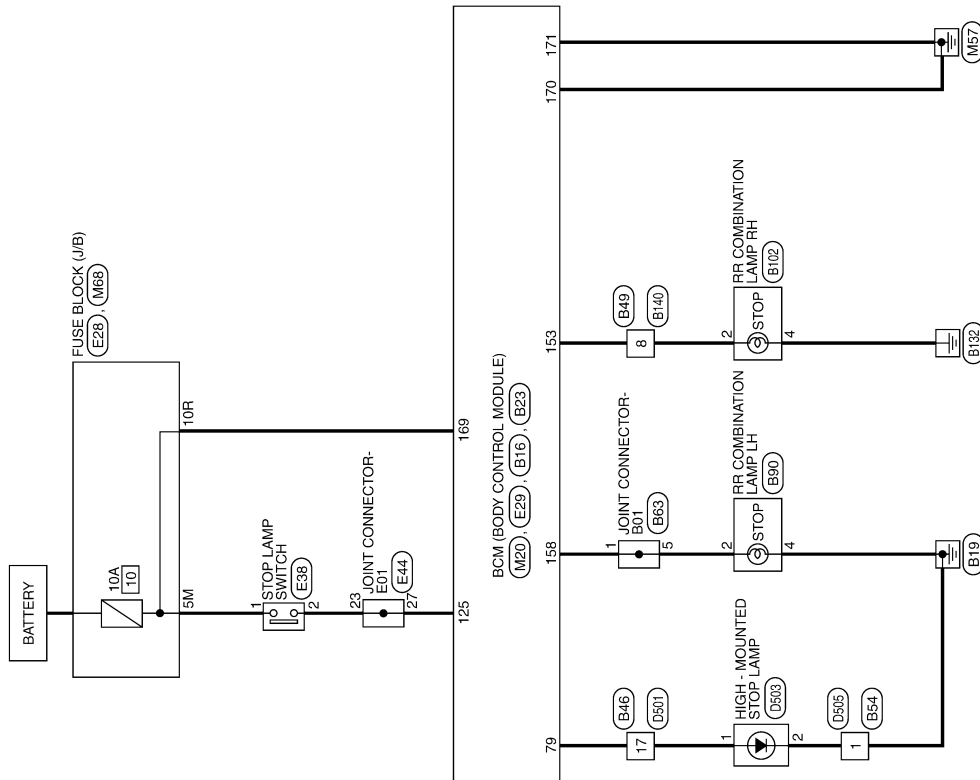

A
B
C
D
E
F
G
H
I
J
K
EXL
M
N
O
P

AALWA1042GB

STOP LAMP

< WIRING DIAGRAM >

[LED HEADLAMP]

STOP LAMP CONNECTORS

Connector No.	M20
Connector Name	BCM (BODY CONTROL MODULE)
Connector Color	BROWN



Terminal No.	Color of Wire	Signal Name
169	GR	I PWR STOP LAMP
170	B	I GND1
171	B	I GND2

Connector No.	M68
Connector Name	FUSE BLOCK (J/B)
Connector Color	BROWN



Terminal No.	Color of Wire	Signal Name
10R	GR	-

Connector No.	E28
Connector Name	FUSE BLOCK (J/B)
Connector Color	WHITE



Terminal No.	Color of Wire	Signal Name
5M	V	-

Connector No.	E29
Connector Name	BCM (BODY CONTROL MODULE)
Connector Color	BLACK

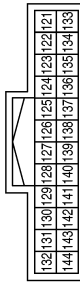

Terminal No.	Color of Wire	Signal Name
125	LG	I BRAKE SW2

Connector No.	E38
Connector Name	STOP LAMP SWITCH
Connector Color	WHITE



Terminal No.	Color of Wire	Signal Name
1	V	-
2	LG	-

Connector No.	E44
Connector Name	JOINT CONNECTOR-E01
Connector Color	WHITE

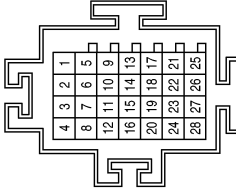

Terminal No.	Color of Wire	Signal Name
23	LG	-
27	LG	-

STOP LAMP

< WIRING DIAGRAM >

[LED HEADLAMP]

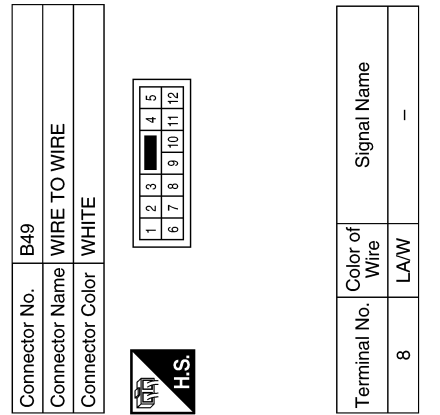
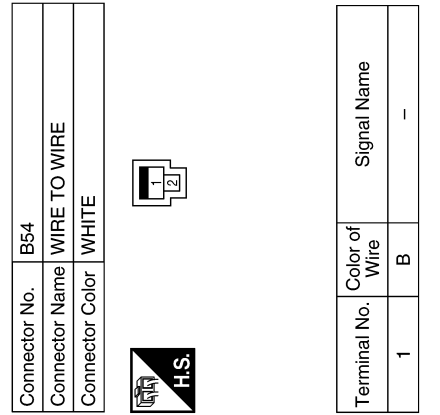
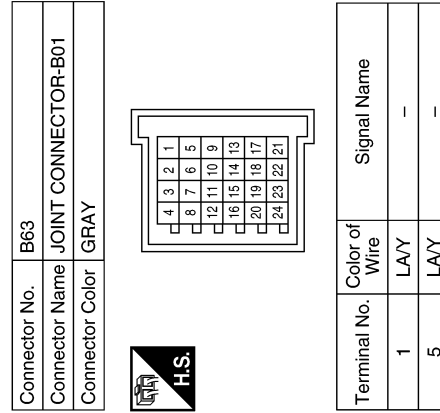
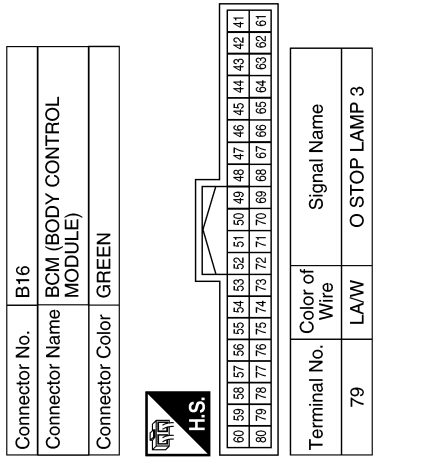
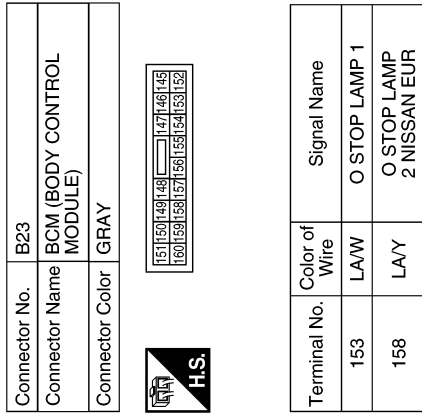
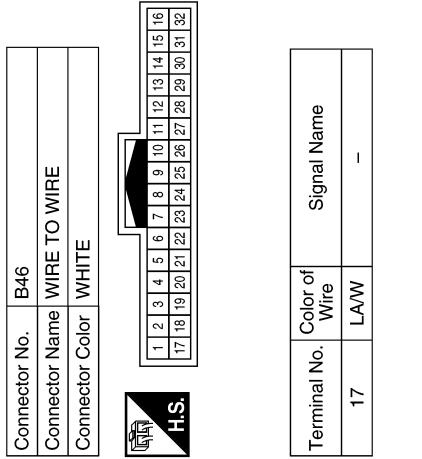

AALIA2159GB

A
B
C
D
E
F
G
H
I
J
K
L
M
N
O
P

EXL

STOP LAMP

< WIRING DIAGRAM >

[LED HEADLAMP]

Connector No.	B140
Connector Name	WIRE TO WIRE
Connector Color	WHITE

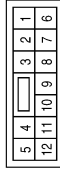

Terminal No.	Color of Wire	Signal Name
8	LA/Y	-

Connector No.	B102
Connector Name	REAR COMBINATION LAMP RH
Connector Color	WHITE



Terminal No.	Color of Wire	Signal Name
2	LA/Y	-
4	B	-

Connector No.	B90
Connector Name	REAR COMBINATION LAMP LH
Connector Color	WHITE



Terminal No.	Color of Wire	Signal Name
2	LA/Y	-
4	B	-

Connector No.	D505
Connector Name	WIRE TO WIRE
Connector Color	WHITE



Terminal No.	Color of Wire	Signal Name
1	B	-

Connector No.	D503
Connector Name	HIGH-MOUNTED STOP LAMP
Connector Color	WHITE



Terminal No.	Color of Wire	Signal Name
1	Y	-
2	B	-

Connector No.	D501
Connector Name	WIRE TO WIRE
Connector Color	WHITE

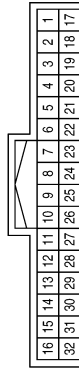

Terminal No.	Color of Wire	Signal Name
17	Y	-

AALIA2160GB

BACK-UP LAMP

< WIRING DIAGRAM >

[LED HEADLAMP]

BACK-UP LAMP

Wiring Diagram

INFOID:0000000011379515

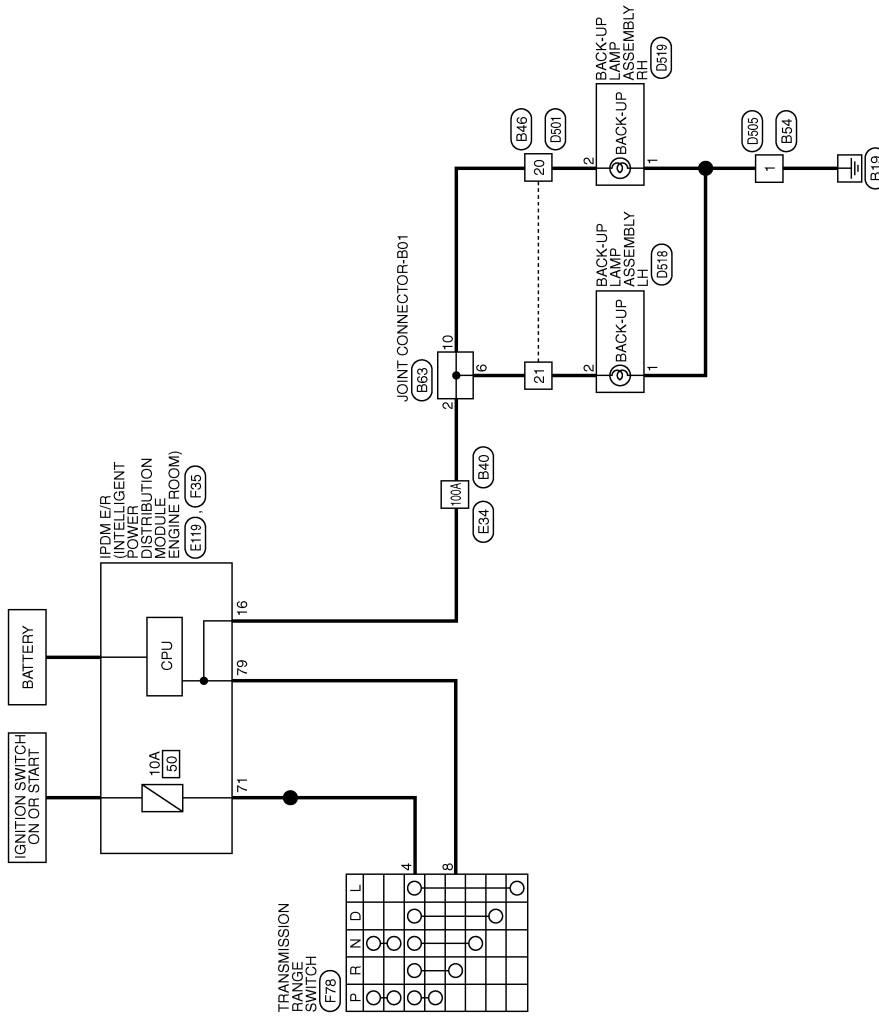

BACK-UP LAMP

A
B
C
D
E
F
G
H
I
J
K
EXL
M
N
O
P

AALWA1044GB

BACK-UP LAMP

< WIRING DIAGRAM >

[LED HEADLAMP]

BACK-UP LAMP CONNECTORS

Connector No.	E34
Connector Name	WIRE TO WIRE
Connector Color	GRAY

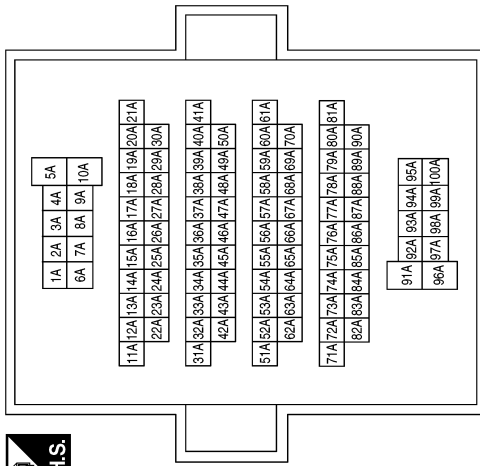

Terminal No.	Color of Wire	Signal Name
100A	G	-

Connector No.	E119
Connector Name	IPDM E/R (INTELLIGENT POWER DISTRIBUTION MODULE ENGINE ROOM)
Connector Color	GRAY

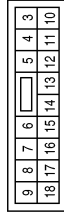

Terminal No.	Color of Wire	Signal Name
16	G	O LIGHT REVERSE LAMP

Connector No.	F35
Connector Name	IPDM E/R (INTELLIGENT POWER DISTRIBUTION MODULE ENGINE ROOM)
Connector Color	WHITE

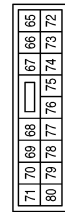

Connector No.	F78
Connector Name	TRANSMISSION RANGE SWITCH
Connector Color	BLACK

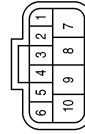

Terminal No.	Color of Wire	Signal Name
71	SB	O IGN REVERSE SW AC VALVE
79	G	LI LIGHT REVERSE SW

Terminal No.	Color of Wire	Signal Name
4	W	-
8	G	-

BACK-UP LAMP

< WIRING DIAGRAM >

[LED HEADLAMP]

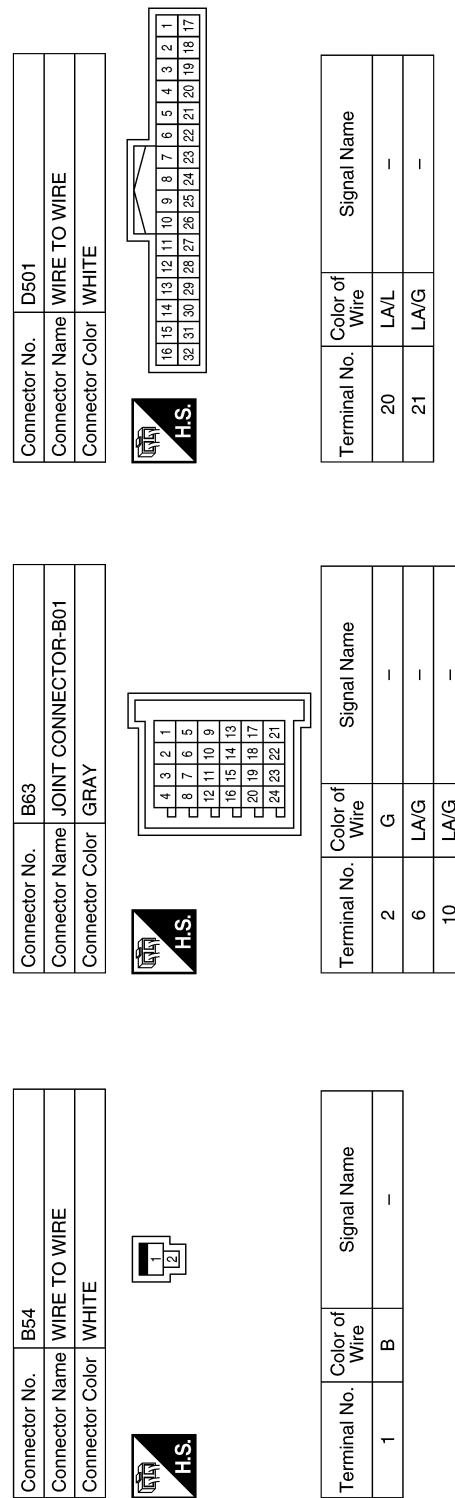
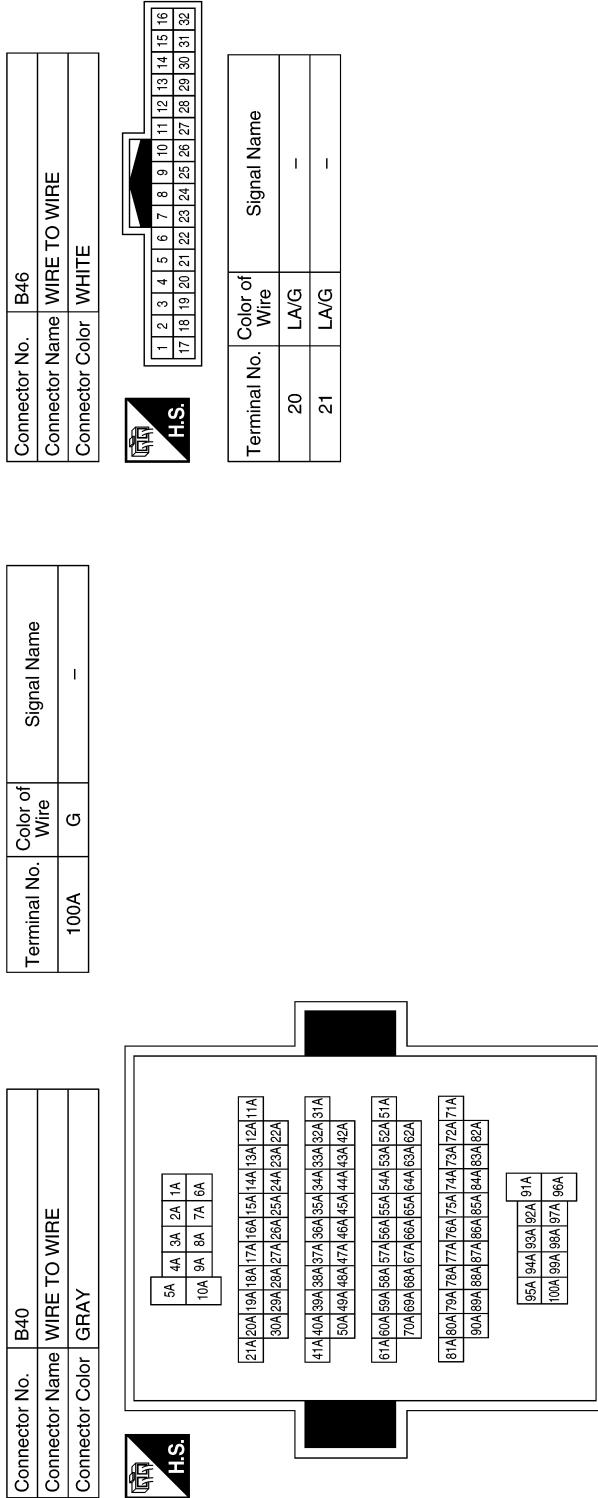

A
B
C
D
E
F
G
H
I
J
K
EXL
M
N
O
P

AALIA2119GB

BACK-UP LAMP

< WIRING DIAGRAM >

[LED HEADLAMP]

Connector No.	D519
Connector Name	BACK-UP LAMP ASSEMBLY RH
Connector Color	WHITE

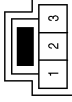

Terminal No.	Color of Wire	Signal Name
1	GR	-
2	LA/L	-

Connector No.	D518
Connector Name	BACK-UP LAMP ASSEMBLY LH
Connector Color	WHITE

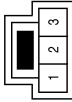

Terminal No.	Color of Wire	Signal Name
1	GR	-
2	LA/G	-

Connector No.	D505
Connector Name	WIRE TO WIRE
Connector Color	WHITE



Terminal No.	Color of Wire	Signal Name
1	B	-

AALIA2120GB

HEADLAMP AIMING SYSTEM (AUTOMATIC)

< WIRING DIAGRAM >

[LED HEADLAMP]

HEADLAMP AIMING SYSTEM (AUTOMATIC)

Wiring Diagram

INFOID:000000011280845

HEADLAMP AIMING SYSTEM

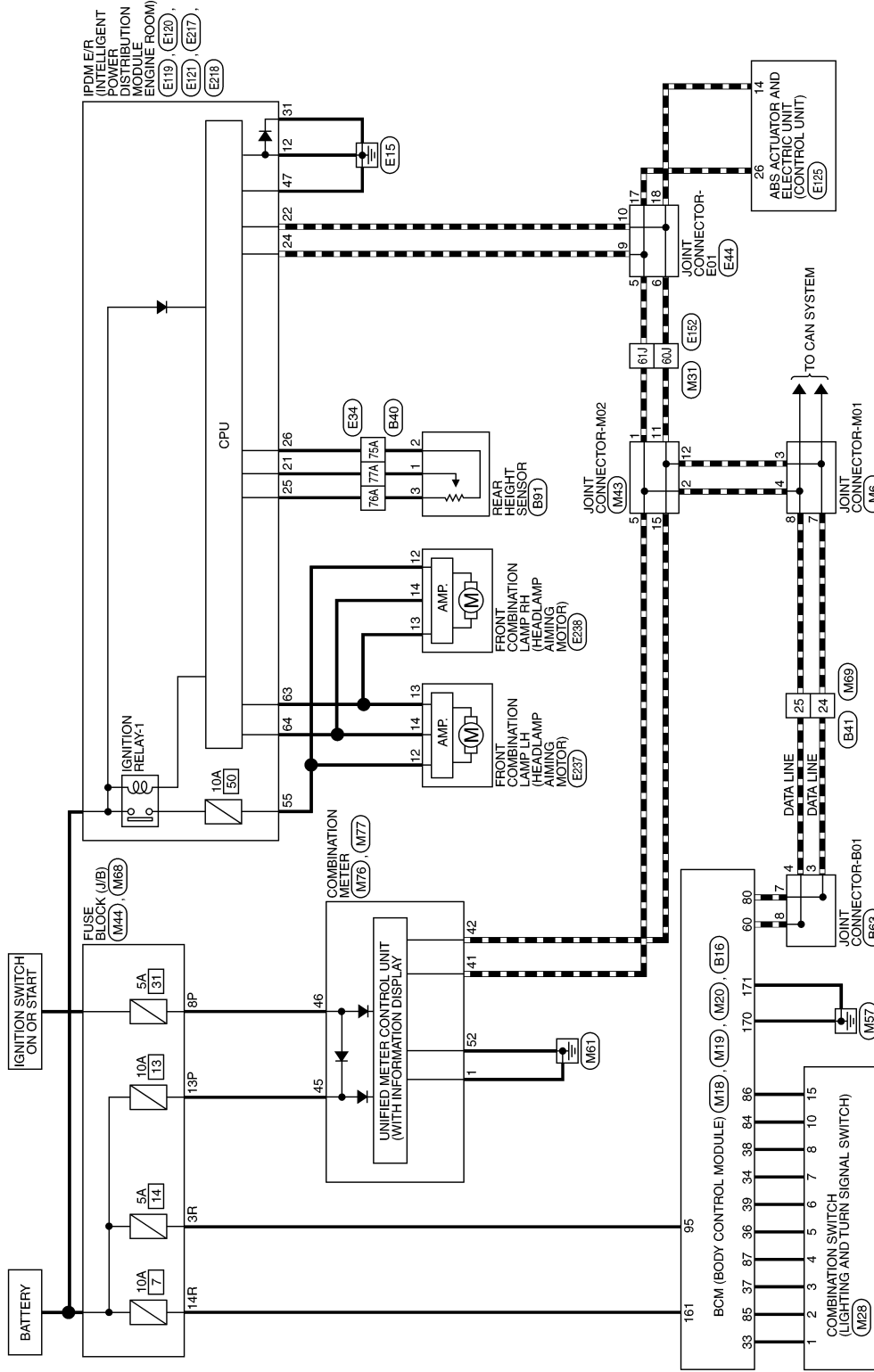

AALWA1049GB

A
B
C
D
E
F
G
H
I
J
K
EXL
M
N
O
P

HEADLAMP AIMING SYSTEM (AUTOMATIC)

< WIRING DIAGRAM >

[LED HEADLAMP]

HEADLAMP AIMING SYSTEM CONNECTORS

Connector No.	M6
Connector Name	JOINT CONNECTOR-M01
Connector Color	GRAY

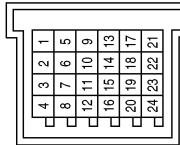

Terminal No.	Color of Wire	Signal Name
3	P	-
4	L	-
7	P	-
8	L	-

Connector No.	M18
Connector Name	BCM (BODY CONTROL MODULE)
Connector Color	GRAY

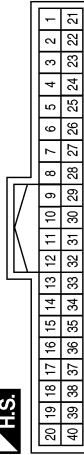

Terminal No.	Color of Wire	Signal Name
33	LG	I CSW 5
34	Y	O CSW 5
36	G	I CSW 3
37	GR	I CSW 4
38	V	I CSW 1
39	W	I CSW 2

Connector No.	M19
Connector Name	BCM (BODY CONTROL MODULE)
Connector Color	BLACK

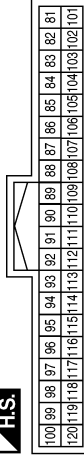

Terminal No.	Color of Wire	Signal Name
84	BR	O CSW 2
85	SB	O CSW 1
86	P	O CSW 3
87	BG	O CSW 4
95	V	I SHORTING PIN

Connector No.	M20
Connector Name	BCM (BODY CONTROL MODULE)
Connector Color	BROWN



Terminal No.	Color of Wire	Signal Name
161	W	I PWR ECU
170	B	I GND1
171	B	I GND2

Connector No.	M28
Connector Name	COMBINATION SWITCH (LIGHTING AND TURN SIGNAL SWITCH)
Connector Color	WHITE

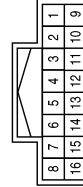

Terminal No.	Color of Wire	Signal Name
1	LG	-
2	SB	-
3	GR	-
4	BG	-

Terminal No.	Color of Wire	Signal Name
5	G	-
6	W	-
7	Y	-
8	V	-
10	BR	-
15	P	-

HEADLAMP AIMING SYSTEM (AUTOMATIC)

< WIRING DIAGRAM >

[LED HEADLAMP]

Connector No.	M43
Connector Name	JOINT CONNECTOR-M02
Connector Color	BLUE

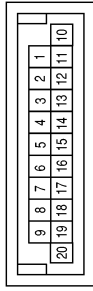

Terminal No.	Color of Wire	Signal Name
1	L	-
2	L	-
5	L	-
11	P	-
12	P	-
15	P	-

Terminal No.	Color of Wire	Signal Name
60J	P	-
61J	L	-

Connector No.	M31
Connector Name	WIRE TO WIRE
Connector Color	WHITE

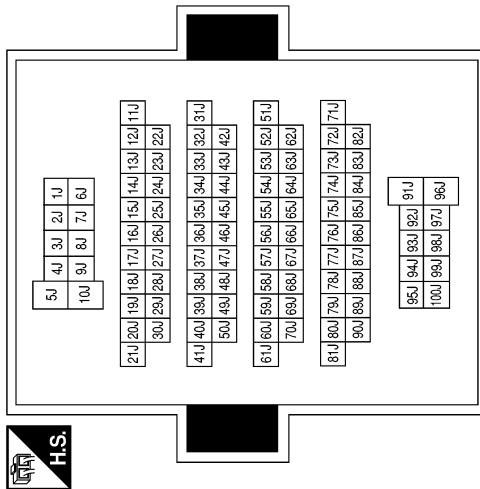

Connector No.	M69
Connector Name	WIRE TO WIRE
Connector Color	WHITE

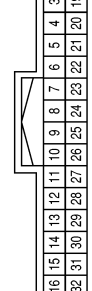

Terminal No.	Color of Wire	Signal Name
24	P	-
25	L	-

Connector No.	M68
Connector Name	FUSE BLOCK (J/B)
Connector Color	BROWN



Terminal No.	Color of Wire	Signal Name
3R	V	-
14R	W	-

Connector No.	M44
Connector Name	FUSE BLOCK (J/B)
Connector Color	WHITE



Terminal No.	Color of Wire	Signal Name
8P	LA/BR	-
13P	LA/G	-

AALIA3017GB

A
B
C
D
E
F
G
H
I
J
K
EXL
M
N
O
P

HEADLAMP AIMING SYSTEM (AUTOMATIC)

< WIRING DIAGRAM >

[LED HEADLAMP]

Connector No.	M77
Connector Name	COMBINATION METER
Connector Color	WHITE

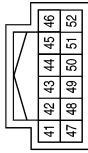

Terminal No.	Color of Wire	Signal Name
41	L	CAN-H
42	P	CAN-L
45	LA/G	BAT
46	LA/BR	IGN
52	B	G1

Connector No.	M76
Connector Name	COMBINATION METER
Connector Color	WHITE

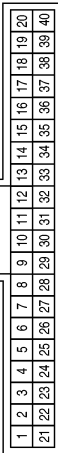

Terminal No.	Color of Wire	Signal Name
1	B	GND

Connector No.	E44
Connector Name	JOINT CONNECTOR-E01
Connector Color	WHITE

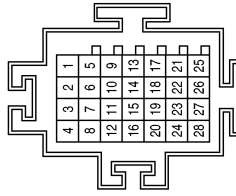

Terminal No.	Color of Wire	Signal Name
5	L	-
6	P	-
9	L	-
10	P	-
17	L	-
18	P	-

Terminal No.	Color of Wire	Signal Name
75A	B	-
76A	G	-
77A	SB	-

Connector No.	E34
Connector Name	WIRE TO WIRE
Connector Color	GRAY

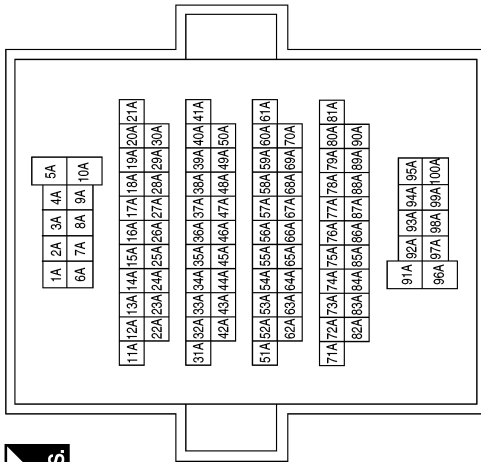

AALIA2971GB

HEADLAMP AIMING SYSTEM (AUTOMATIC)

< WIRING DIAGRAM >

[LED HEADLAMP]

Connector No.	E121
Connector Name	IPDM E/R (INTELLIGENT POWER DISTRIBUTION MODULE ENGINE ROOM)
Connector Color	RED



Terminal No.	Color of Wire	Signal Name
47	B	POWER GROUND

Connector No.	E120
Connector Name	IPDM E/R (INTELLIGENT POWER DISTRIBUTION MODULE ENGINE ROOM)
Connector Color	GRAY

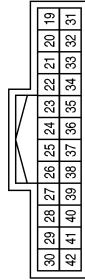

Terminal No.	Color of Wire	Signal Name
21	SB	I HEIGHT REAR
22	P	CAN-L
24	L	CAN-H
25	G	O HEIGHT SENSOR SUPPLY
26	B	O HEIGHT SENSOR GROUND
31	B	2ND SIGNAL GROUND

Connector No.	E119
Connector Name	IPDM E/R (INTELLIGENT POWER DISTRIBUTION MODULE ENGINE ROOM)
Connector Color	GRAY

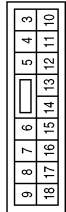

Terminal No.	Color of Wire	Signal Name
12	B	SIGNAL GROUND

Connector No.	E125
Connector Name	ABS ACTUATOR AND ELECTRIC UNIT (CONTROL UNIT)
Connector Color	BLACK

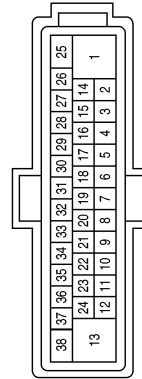

Terminal No.	Color of Wire	Signal Name
14	P	CAN-L
26	L	CAN-H

AALIA2972GB

A
B
C
D
E
F
G
H
I
J
K
EXL
M
N
O
P

HEADLAMP AIMING SYSTEM (AUTOMATIC)

< WIRING DIAGRAM >

[LED HEADLAMP]

Connector No.	E217
Connector Name	IPDM E/R (INTELLIGENT POWER DISTRIBUTION MODULE ENGINE ROOM)
Connector Color	BROWN

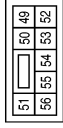

Terminal No.	Color of Wire	Signal Name
55	SB	O IGN REVERSE SW AC VALVE 1

Terminal No.	Color of Wire	Signal Name
60J	P	-
61J	L	-

Connector No.	E152
Connector Name	WIRE TO WIRE
Connector Color	WHITE

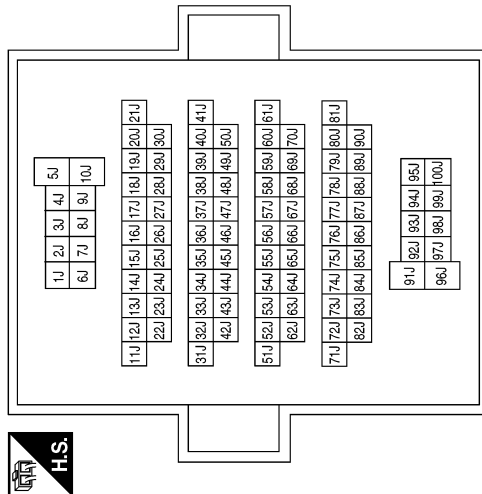

Connector No.	E238
Connector Name	FRONT COMBINATION LAMP RH (HEAD LAMP AIMING MOTOR)
Connector Color	BLACK



Terminal No.	Color of Wire	Signal Name
12	SB	-
13	B	-
14	V	-

Connector No.	E237
Connector Name	FRONT COMBINATION LAMP LH (HEAD LAMP AIMING MOTOR)
Connector Color	BLACK



Terminal No.	Color of Wire	Signal Name
12	L	-
13	B	-
14	V	-

Connector No.	E218
Connector Name	IPDM E/R (INTELLIGENT POWER DISTRIBUTION MODULE ENGINE ROOM)
Connector Color	WHITE



Terminal No.	Color of Wire	Signal Name
63	B	I LEVELIZER DC MOTOR GROUND
64	V	O LEVELIZER DC MOTOR

AALIA2973GB

HEADLAMP AIMING SYSTEM (AUTOMATIC)

< WIRING DIAGRAM >

[LED HEADLAMP]

Terminal No.	Color of Wire	Signal Name
75A	B	-
76A	G	-
77A	SB	-

Connector No.	B40
Connector Name	WIRE TO WIRE
Connector Color	GRAY

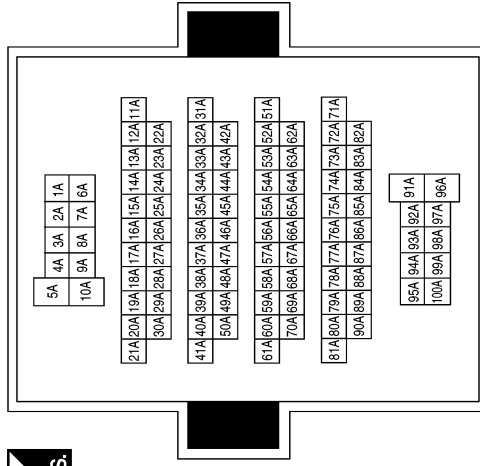

Connector No.	B16
Connector Name	BCM (BODY CONTROL MODULE)
Connector Color	GREEN



60	59	58	57	56	55	54	53	52	51	50	49	48	47	46	45	44	43	42	41
80	79	78	77	76	75	74	73	72	71	70	69	68	67	66	65	64	63	62	61

Terminal No.	Color of Wire	Signal Name
60	L	CAN-H
80	P	CAN-L

Connector No.	B91
Connector Name	REAR HEIGHT SENSOR
Connector Color	BLACK



Connector No.	B63
Connector Name	JOINT CONNECTOR-B01
Connector Color	GRAY

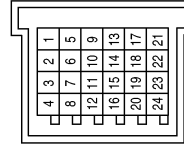

Connector No.	B41
Connector Name	WIRE TO WIRE
Connector Color	WHITE

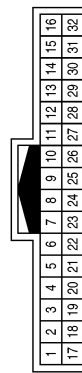

Terminal No.	Color of Wire	Signal Name
1	SB	-
2	B	-
3	G	-

Terminal No.	Color of Wire	Signal Name
3	P	-
4	L	-
7	P	-
8	L	-

Terminal No.	Color of Wire	Signal Name
24	P	-
25	L	-

AALIA2981GB

A
B
C
D
E
F
G
H
I
J
K
EXL
M
N
O
P

DIAGNOSIS AND REPAIR WORKFLOW

< BASIC INSPECTION >

[LED HEADLAMP]

BASIC INSPECTION

DIAGNOSIS AND REPAIR WORKFLOW

Work Flow

INFOID:000000011280846

OVERALL SEQUENCE

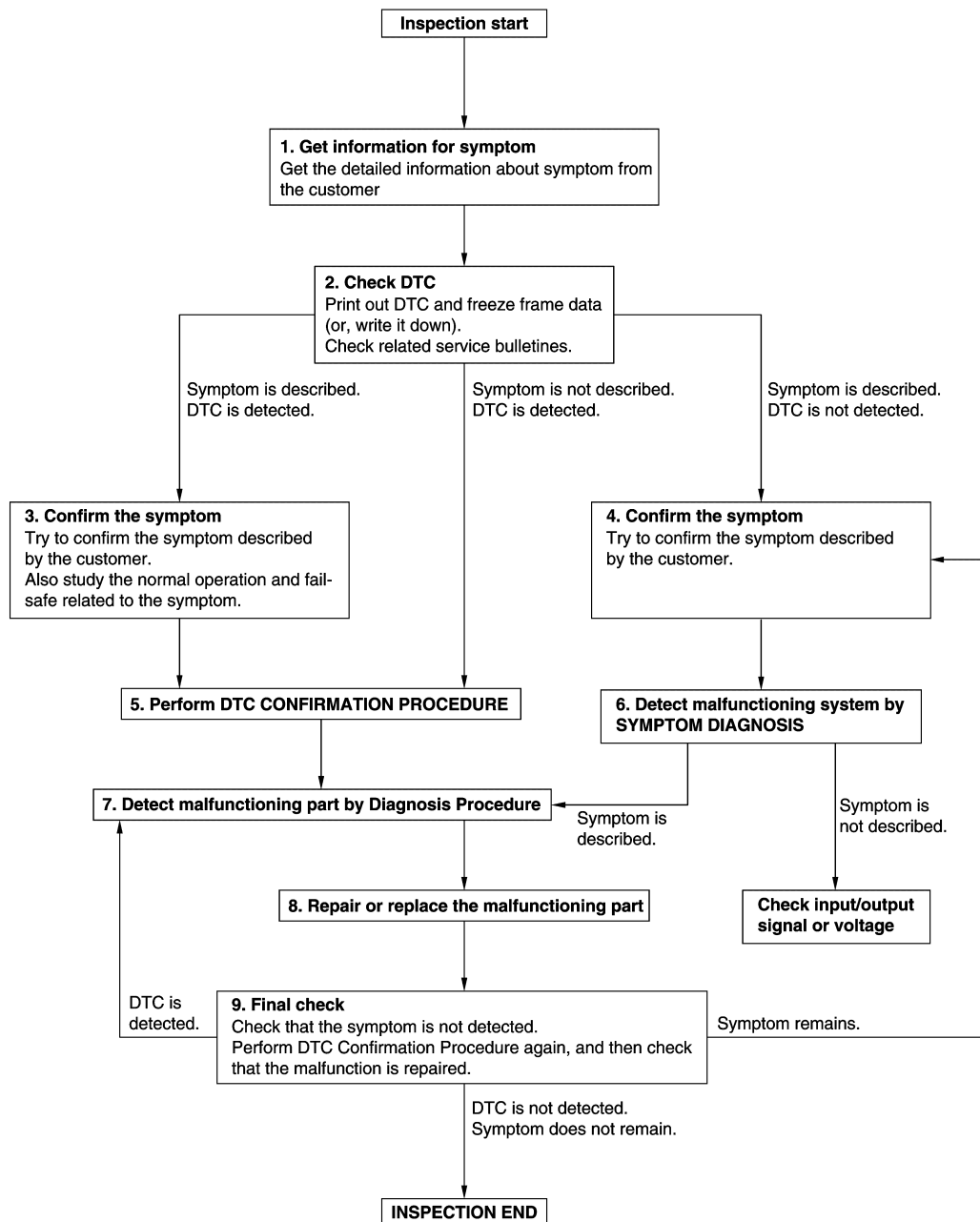

DETAILED FLOW

Revision: August 2014

EXL-218

JMKIA8652GB

2015 Rogue NAM

DIAGNOSIS AND REPAIR WORKFLOW

< BASIC INSPECTION >

[LED HEADLAMP]

1. GET INFORMATION FOR SYMPTOM

1. Get detailed information from the customer about the symptom (the condition and the environment when the incident/malfunction occurs).
2. Check operation condition of the function that is malfunctioning.

>> GO TO 2.

2. CHECK DTC

1. Check DTC.
2. Perform the following procedure if DTC is detected:
 - Record DTC and freeze frame data (Print them out using CONSULT.)
 - Erase DTC.
 - Study the relationship between the cause detected by DTC and the symptom described by the customer.
3. Check related service bulletins for information.

Are any symptoms described and any DTC detected?

Symptom is described, DTC is detected>>GO TO 3.

Symptom is described, DTC is not detected>>GO TO 4.

Symptom is not described, DTC is detected>>GO TO 5.

3. CONFIRM THE SYMPTOM

Try to confirm the symptom described by the customer.

Also study the normal operation and fail-safe related to the symptom.

Verify relation between the symptom and the condition when the symptom is detected.

>> GO TO 5.

4. CONFIRM THE SYMPTOM

Try to confirm the symptom described by the customer.

Verify relation between the symptom and the condition when the symptom is detected.

>> GO TO 6.

5. PERFORM DTC CONFIRMATION PROCEDURE

Perform DTC CONFIRMATION PROCEDURE for the detected DTC, and then check that DTC is detected again. At this time, always connect CONSULT to the vehicle, and check self diagnostic results in real time.

If two or more DTCs are detected, refer to [BCS-46, "DTC Inspection Priority Chart"](#) (with Intelligent Key system) or [BCS-107, "DTC Inspection Priority Chart"](#) (without Intelligent Key system) (BCM) or [PCS-22, "DTC Index"](#) (IPDM E/R), and determine trouble diagnosis order.

NOTE:

- Freeze frame data is useful if the DTC is not detected.
- Perform Component Function Check if DTC CONFIRMATION PROCEDURE is not included on Service Manual. This simplified check procedure is an effective alternative though DTC cannot be detected during this check.
If the result of Component Function Check is NG, it is the same as the detection of DTC by DTC CONFIRMATION PROCEDURE.

Is DTC detected?

YES >> GO TO 7.

NO >> Check according to [GI-44, "Intermittent Incident"](#).

6. DETECT MALFUNCTIONING SYSTEM BY SYMPTOM DIAGNOSIS

Detect malfunctioning system according to SYMPTOM DIAGNOSIS based on the confirmed symptom in step 4, and determine the trouble diagnosis order based on possible causes and symptom.

Is the symptom described?

YES >> GO TO 7.

NO >> Monitor input data from related sensors or check voltage of related module terminals using CONSULT.

A
B
C
D
E
F
G
H
I
J
K
EXL
M
N
O
P

DIAGNOSIS AND REPAIR WORKFLOW

< BASIC INSPECTION >

[LED HEADLAMP]

7. DETECT MALFUNCTIONING PART BY DIAGNOSTIC PROCEDURE

Inspect according to Diagnostic Procedure of the system.

Is malfunctioning part detected?

YES >> GO TO 8.

NO >> Check according to [GI-44. "Intermittent Incident"](#).

8. REPAIR OR REPLACE THE MALFUNCTIONING PART

1. Repair or replace the malfunctioning part.
2. Reconnect parts or connectors disconnected during Diagnostic Procedure again after repair and replacement.
3. Check DTC. If DTC is detected, erase it.

>> GO TO 9.

9. FINAL CHECK

When DTC is detected in step 2, perform DTC CONFIRMATION PROCEDURE again, and then check that the malfunction is repaired securely.

When symptom is described by the customer, refer to confirmed symptom in step 3 or 4, and check that the symptom is not detected.

Is DTC detected and does symptom remain?

YES-1 >> DTC is detected: GO TO 7.

YES-2 >> Symptom remains: GO TO 4.

NO >> Before returning the vehicle to the customer, always erase DTC.

INSPECTION AND ADJUSTMENT

< BASIC INSPECTION >

[LED HEADLAMP]

INSPECTION AND ADJUSTMENT

ADDITIONAL SERVICE WHEN REPLACING CONTROL UNIT

ADDITIONAL SERVICE WHEN REPLACING CONTROL UNIT : Description

INFOID:0000000011280847

CAUTION:

- When the IPDM E/R is replaced or disconnected and reconnected, perform “SENSOR INITIALIZE” with CONSULT.

ADDITIONAL SERVICE WHEN REPLACING CONTROL UNIT : Special Repair Requirement

INFOID:0000000011280848

1.SENSOR INITIALIZE

CONSULT WORK SUPPORT

Perform “SENSOR INITIALIZE”. Refer to [EXL-221, "SENSOR INITIALIZE : Special Repair Requirement"](#).

>> Work End.

SENSOR INITIALIZE

SENSOR INITIALIZE : Description

INFOID:0000000011280849

HEADLAMP AIMING CONTROL SYSTEM

Perform the sensor initialize when installing, removing and replacing the rear height sensor or suspension components.

SENSOR INITIALIZE : Special Repair Requirement

INFOID:0000000011280850

CAUTION:

When performing aiming adjustment after the levelizer initialization, be sure to start the engine after turning ignition switch OFF.

1.VEHICLE CONDITION CHECK

1. Park the vehicle in the straight-forward position.
2. Unload the vehicle (no passenger aboard).

>> GO TO 2.

2.SENSOR INITIALIZE

CONSULT WORK SUPPORT

1. Select “SENSOR INITIALIZE” in “Work Support” of “IPDM E/R”.
2. Select “START”.
3. When “INITIALIZE COMPLETE”, select “END”.

CAUTION:

If “INITIALIZE NOT DONE” is indicated, auto levelizer control unit detects that the sensor lever signal was changing. The sensor initialization is cancelled. In this case, turn the ignition switch OFF, do not allow the vehicle height to change. Perform the sensor initialization again.

Is the sensor initialize completed?

- YES >> GO TO 3.
NO >> Perform the sensor initialize again.

3.SELF DIAGNOSTIC RESULT CHECK

Perform the “Self Diagnostic Result” with CONSULT. Check that any DTC is not detected.

Is any DTC detected?

- YES >> GO TO 2.
NO >> GO TO 4.

4.PERFORM HEADLAMP AIMING ADJUSTMENT

A
B
C
D
E
F
G
H
I
J
K
EXL
M
N
O
P

INSPECTION AND ADJUSTMENT

< BASIC INSPECTION >

[LED HEADLAMP]

Perform headlamp aiming adjustment. Refer to [EXL-262. "Aiming Adjustment Procedure"](#).

>> Work End.

LED HEADLAMP OPERATION INSPECTION

< BASIC INSPECTION >

[LED HEADLAMP]

LED HEADLAMP OPERATION INSPECTION

Diagnosis Procedure

INFOID:000000011280851

1. CHECK START

1. In the cool LED status (wait for more than 10 minutes after turning headlamp OFF), turn ON and turn OFF headlamp for the several times. Check that headlamp operates normally each time.
2. In the cool LED status, turn headlamp ON, wait until headlamp enters to the stable status (approximately 5 minutes after turning headlamp ON), and then check that headlamp operates normally without blinking or flickering.
3. In the warm LED status (turn headlamp ON for more than 15 minutes and wait for 1 minute after turning OFF), turn ON and turn OFF headlamp for the several times. Check that headlamp operates normally each time.
4. Turn headlamp ON for approximately 30 minutes, and then check that headlamp operates normally without difference in brightness between LH and RH, blinking or flickering.

Is the inspection result normal?

- YES >> Inspection End.
NO >> Refer to [EXL-254, "Symptom Table"](#).

A
B
C
D
E
F
G
H
I
J
K
EXL
M
N
O
P

POWER SUPPLY AND GROUND CIRCUIT

< DTC/CIRCUIT DIAGNOSIS >

[LED HEADLAMP]

DTC/CIRCUIT DIAGNOSIS

POWER SUPPLY AND GROUND CIRCUIT

BCM (BODY CONTROL SYSTEM) (WITH INTELLIGENT KEY SYSTEM)

BCM (BODY CONTROL SYSTEM) (WITH INTELLIGENT KEY SYSTEM) : Diagnosis Procedure

INFOID:000000011421500

Regarding Wiring Diagram information, refer to [BCS-50, "Wiring Diagram"](#).

1. CHECK FUSE

Check that the following fuse is not blown.

Terminal No.	Signal name	Fuse No.
161	BCM power supply	7 (10A)

Is the fuse blown?

- YES >> Replace the blown fuse after repairing the affected circuit.
NO >> GO TO 2.

2. CHECK POWER SUPPLY CIRCUIT

1. Disconnect BCM connector M20.
2. Check voltage between BCM connector M20 and ground.

BCM		Ground	Voltage (Approx.)
Connector	Terminal		
M20	161	—	Battery voltage

Is the inspection result normal?

- YES >> GO TO 3.
NO >> Repair or replace harness or connectors.

3. CHECK GROUND CIRCUIT

Check continuity between BCM connector M20 and ground.

BCM		Ground	Continuity
Connector	Terminal		
M20	170	—	Yes
	171		

Is the inspection result normal?

- YES >> Inspection End.
NO >> Repair or replace harness or connectors.

BCM (BODY CONTROL SYSTEM) (WITHOUT INTELLIGENT KEY SYSTEM)

BCM (BODY CONTROL SYSTEM) (WITHOUT INTELLIGENT KEY SYSTEM) : Diagnosis Procedure

INFOID:000000011421501

Regarding Wiring Diagram information, refer to [BCS-110, "Wiring Diagram"](#).

1. CHECK FUSE

POWER SUPPLY AND GROUND CIRCUIT

< DTC/CIRCUIT DIAGNOSIS >

[LED HEADLAMP]

Check that the following fuse is not blown.

Terminal No.	Signal name	Fuse No.
161	BCM power supply	7 (10A)

Is the fuse blown?

- YES >> Replace the blown fuse after repairing the affected circuit.
NO >> GO TO 2.

2. CHECK POWER SUPPLY CIRCUIT

1. Disconnect BCM connector M20.
2. Check voltage between BCM connector M20 and ground.

BCM		Ground	Voltage (Approx.)
Connector	Terminal		
M20	161	—	Battery voltage

Is the inspection result normal?

- YES >> GO TO 3.
NO >> Repair or replace harness or connectors.

3. CHECK GROUND CIRCUIT

Check continuity between BCM connector M20 and ground.

BCM		Ground	Continuity
Connector	Terminal		
M20	170	—	Yes
	171		

Is the inspection result normal?

- YES >> Inspection End.
NO >> Repair or replace harness or connectors.

A
B
C
D
E
F
G
H
I
J
K
EXL
M
N
O
P

OPTICAL SENSOR

< DTC/CIRCUIT DIAGNOSIS >

[LED HEADLAMP]

OPTICAL SENSOR

Component Function Check

INFOID:0000000011421502

1.CHECK OPTICAL SENSOR SIGNAL BY CONSULT

CONSULT DATA MONITOR

1. Turn ignition switch ON.
2. Select "OPTICAL SENSOR" in "Data Monitor" of "BCM (HEADLAMP)".
3. Turn lighting switch AUTO.
4. With the optical sensor illuminating, check the monitor status.

Monitor item	Condition		Voltage (Approx.)
OPTICAL SENSOR	Optical sensor	When illuminating	3.1 V or more *
		When shutting off light	0.6 V or less

*: Illuminates the optical sensor. The value may be less than the standard value if brightness is weak.

Is the inspection result normal?

- YES >> Optical sensor is normal.
NO >> Refer to [EXL-226, "Diagnosis Procedure"](#).

Diagnosis Procedure

INFOID:0000000011421503

1.CHECK OPTICAL SENSOR POWER SUPPLY INPUT

1. Turn ignition switch ON.
2. Turn lighting switch AUTO.
3. Check voltage between optical sensor harness connector and ground.

(+)		(-)	Voltage (Approx.)
Optical sensor			
Connector	Terminal	Ground	5 V
M13	1		

Is the inspection result normal?

- YES >> GO TO 2.
NO >> GO TO 4.

2.CHECK OPTICAL SENSOR GROUND INPUT

Check voltage between optical sensor harness connector and ground.

(+)		(-)	Voltage (Approx.)
Optical sensor			
Connector	Terminal	Ground	0 V
M13	3		

Is the inspection result normal?

- YES >> GO TO 3.
NO >> GO TO 6.

3.CHECK OPTICAL SENSOR SIGNAL OUTPUT

With illuminating the optical sensor, check voltage between optical sensor harness connector and ground.

OPTICAL SENSOR

< DTC/CIRCUIT DIAGNOSIS >

[LED HEADLAMP]

(+)		(-)	Condition	Voltage (Approx.)
Optical sensor				
Connector	Terminal			
M13	2	Ground	Optical sensor	When illuminating 3.1 V or more *
				When shutting off light 0.6 V or less

*: Illuminate the optical sensor. The value may be less than the standard if brightness is weak.

Is the inspection result normal?

YES >> GO TO 7.

NO >> Replace the optical sensor.

4. CHECK OPTICAL SENSOR OPEN CIRCUIT

1. Turn ignition switch OFF.
2. Disconnect optical sensor connector and BCM connector.
3. Check continuity between optical sensor harness connector and BCM harness connector.

Optical sensor		BCM		Continuity
Connector	Terminal	Connector	Terminal	
M13	1	M18	12	Yes

Is the inspection result normal?

YES >> GO TO 5.

NO >> Repair or replace harness.

5. CHECK OPTICAL SENSOR SHORT CIRCUIT

Check continuity between optical sensor harness connector and ground.

Optical sensor		Ground	Continuity
Connector	Terminal		
M13	1		No

Is the inspection result normal?

YES >> Replace BCM. Refer to [BCS-75, "Removal and Installation"](#) (with Intelligent Key system) or [BCS-135, "Removal and Installation"](#) (without Intelligent Key system).

NO >> Repair or replace harness.

6. CHECK OPTICAL SENSOR GROUND OPEN CIRCUIT

1. Turn ignition switch OFF.
2. Disconnect optical sensor connector and BCM connector.
3. Check continuity between optical sensor harness connector and BCM harness connector.

Optical sensor		BCM		Continuity
Connector	Terminal	Connector	Terminal	
M13	3	M18	30	Yes

Is the inspection result normal?

YES >> Replace BCM. Refer to [BCS-75, "Removal and Installation"](#) (with Intelligent Key system) or [BCS-135, "Removal and Installation"](#) (without Intelligent Key system).

NO >> Repair or replace harness.

7. CHECK OPTICAL SENSOR SIGNAL OPEN CIRCUIT

1. Turn ignition switch OFF.
2. Disconnect optical sensor connector and BCM connector.
3. Check continuity between optical sensor harness connector and BCM harness connector.

OPTICAL SENSOR

< DTC/CIRCUIT DIAGNOSIS >

[LED HEADLAMP]

Optical sensor		BCM		Continuity
Connector	Terminal	Connector	Terminal	
M13	2	M18	19	Yes

Is the inspection result normal?

YES >> GO TO 8.

NO >> Repair or replace harness.

8. CHECK OPTICAL SENSOR SHORT CIRCUIT

Check continuity between optical sensor harness connector and ground.

Optical sensor		Ground	Continuity
Connector	Terminal		
M13	2		No

Is the inspection result normal?

YES >> Replace BCM. Refer to [BCS-75. "Removal and Installation"](#) (with Intelligent Key system) or [BCS-135. "Removal and Installation"](#) (without Intelligent Key system).

NO >> Repair or replace harness.

HAZARD SWITCH

< DTC/CIRCUIT DIAGNOSIS >

[LED HEADLAMP]

HAZARD SWITCH

Component Function Check

INFOID:0000000011421504

1.CHECK HAZARD SWITCH SIGNAL BY CONSULT

CONSULT DATA MONITOR

1. Turn ignition switch ON.
2. Select "HAZARD SW" in "Data Monitor" of "BCM (FLASHER)".
3. With operating the hazard switch, check the monitor status.

Monitor item	Condition		Monitor status
HAZARD SW	Hazard switch	ON	On
		OFF	Off

Is the inspection result normal?

- YES >> Hazard switch circuit is normal.
 NO >> Refer to [EXL-229. "Diagnosis Procedure"](#).

Diagnosis Procedure

INFOID:0000000011421505

1.CHECK HAZARD SWITCH SIGNAL INPUT

1. Turn ignition switch OFF.
2. Disconnect hazard switch connector.
3. Check voltage between hazard switch connector and ground.

(+)		(-)	Voltage (Approx.)
Hazard switch			
Connector	Terminal	Ground	Battery voltage
M26	2		

Is the inspection result normal?

- YES >> GO TO 4.
 NO >> GO TO 2.

2.CHECK HAZARD SWITCH SIGNAL OPEN CIRCUIT

1. Disconnect BCM connector.
2. Check continuity between hazard switch harness connector and BCM harness connector.

Hazard switch		BCM		Continuity
Connector	Terminal	Connector	Terminal	
M26	2	M18	11	Yes

Is the inspection result normal?

- YES >> GO TO 3.
 NO >> Repair or replace harness.

3.CHECK HAZARD SWITCH SIGNAL SHORT CIRCUIT

Check continuity between hazard switch harness connector and ground.

Hazard switch		Ground	Continuity
Connector	Terminal		
M26	2		No

Is the inspection result normal?

- YES >> Replace BCM. Refer to [BCS-75. "Removal and Installation"](#) (with Intelligent Key system) or [BCS-135. "Removal and Installation"](#) (without Intelligent Key system).
 NO >> Repair or replace harness.

HAZARD SWITCH

< DTC/CIRCUIT DIAGNOSIS >

[LED HEADLAMP]

4. CHECK HAZARD SWITCH GROUND OPEN CIRCUIT

Check continuity between hazard switch harness connector and ground.

Hazard switch		Ground	Continuity
Connector	Terminal		Yes
M26	3		

Is the inspection result normal?

- YES >> Replace hazard switch. Refer to [EXL-125, "Removal and Installation"](#).
- NO >> Repair or replace harness.

TURN SIGNAL LAMP CIRCUIT

< DTC/CIRCUIT DIAGNOSIS >

[LED HEADLAMP]

TURN SIGNAL LAMP CIRCUIT

Description

INFOID:0000000011421523

The BCM monitors inputs from the combination switch (lighting and turn signal switch) to determine when to activate the turn signals. The BCM outputs voltage direction to the left and right turn signals during turn signal operation or both during hazard warning operation. The BCM sends a turn signal indicator request to the combination meter via the CAN communication lines.

The BCM performs the fast flasher operation (fail-safe) if any bulb or harness of the turn signal lamp circuit is open.

NOTE:

Turn signal lamp blinks at normal speed when using the hazard warning lamp.

Component Function Check

INFOID:0000000011421524

1. CHECK TURN SIGNAL LAMP

CONSULT

1. Select "FLASHER" in "Active Test" of "BCM (FLASHER)".
2. While operating the test items, check that the turn signal lamp blinks.

LH : Turn signal lamps (LH) ON

RH : Turn signal lamps (RH) ON

Off : Turn signal lamps OFF

Is the inspection result normal?

YES >> Turn signal lamp circuit is normal.

NO >> Refer to [EXL-231, "Diagnosis Procedure"](#).

Diagnosis Procedure

INFOID:0000000011421525

Regarding Wiring Diagram information, refer to [EXL-185, "Wiring Diagram"](#).

1. CHECK TURN SIGNAL LAMP BULB

Check the applicable lamp bulb to be sure the proper bulb standard is in use and the bulb is not open.

Is the bulb OK?

YES >> GO TO 2.

NO >> Replace the bulb.

2. CHECK TURN SIGNAL LAMP OUTPUT VOLTAGE

1. Turn the ignition switch OFF.
2. Disconnect the front combination lamp harness connector, door mirror harness connector or the side turn signal harness connector or the rear combination lamp harness connector in question.
3. Turn the ignition switch ON.
4. Operate the turn signal switch.
5. While the turn signal is operating, check the voltage between the front combination lamp harness connector and ground.

(+)		(-)	Voltage (Approx.)
Connector	Terminal		

TURN SIGNAL LAMP CIRCUIT

< DTC/CIRCUIT DIAGNOSIS >

[LED HEADLAMP]

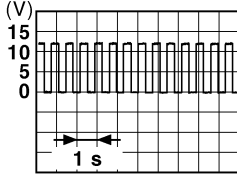
LH	E105			
RH	E103	1	Ground	 <small>PKID0926E</small>

6. While the turn signal is operating, check the voltage between the door mirror harness connector and ground.

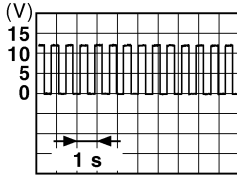
(+)		Terminal	(-)	Voltage (Approx.)
Connector				
LH	D14	13	Ground	 <small>PKID0926E</small>
RH	D107			

7. While the turn signal is operating, check the voltage between the rear combination lamp harness connector and ground.

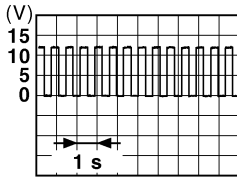
(+)		Terminal	(-)	Voltage (Approx.)
Connector				
LH	B90	3	Ground	 <small>PKID0926E</small>
RH	B102			

Are the inspection results normal?

YES >> GO TO 5.

NO >> GO TO 3.

3. CHECK TURN SIGNAL LAMP CIRCUIT FOR OPEN

1. Turn the ignition switch OFF.
2. Disconnect BCM harness connector E29, M18 or B23.
3. Check continuity between the BCM harness connector E29 and the front combination lamp harness connector.

BCM			Front combination lamp		Continuity
Connector	Terminal	Connector	Terminal		
LH	E29	135	E105	1	Yes
RH		136	E103		

4. Check continuity between the BCM harness connector B23 and the door mirror harness connector.

BCM			Door mirror		Continuity
Connector	Terminal	Connector	Terminal		
LH	M18	2	D14	13	Yes
RH		3	D107		

TURN SIGNAL LAMP CIRCUIT

[LED HEADLAMP]

< DTC/CIRCUIT DIAGNOSIS >

5. Check continuity between the BCM harness connector B23 and the rear combination lamp harness connector.

BCM		Rear combination lamp		Continuity
Connector	Terminal	Connector	Terminal	
LH	B23	157	B90	Yes
RH		160	B102	

Are the inspection results normal?

YES >> GO TO 4.

NO >> Repair or replace the harness or connectors.

4. CHECK TURN SIGNAL LAMP SHORT CIRCUIT

1. Check continuity between the BCM harness connector E29 and ground.

BCM		Ground	Continuity
Connector	Terminal		
LH	E29	135	No
RH		136	

2. Check continuity between the BCM harness connector M18 and ground.

BCM		Ground	Continuity
Connector	Terminal		
LH	B18	2	No
RH		3	

3. Check continuity between the BCM harness connector M23 and ground.

BCM		Ground	Continuity
Connector	Terminal		
LH	B23	157	No
RH		160	

Are the inspection results normal?

YES >> Replace BCM. Refer to [BCS-75. "Removal and Installation"](#) (with Intelligent Key system) or [BCS-135. "Removal and Installation"](#) (without Intelligent Key system).

NO >> Repair or replace the harness or connectors.

5. CHECK TURN SIGNAL LAMP GROUND CIRCUIT

1. Turn the ignition switch OFF.
2. Check continuity between the front combination lamp harness connector, the door mirror connector or the rear combination lamp harness connector in question and ground.

Front combination lamp		(-)	Continuity
Connector	Terminal		
LH	E105	Ground	Yes
RH	E103		

3. Check continuity between the door mirror harness connector and ground.

Door mirror		(-)	Continuity
Connector	Terminal		

TURN SIGNAL LAMP CIRCUIT

< DTC/CIRCUIT DIAGNOSIS >

[LED HEADLAMP]

LH	D14	14	Ground	Yes
RH	D107			

4. Check continuity between the rear combination lamp harness connector and ground.

Rear combination lamp		Terminal	(-)	Continuity
Connector				
LH	B90	4	Ground	Yes
RH	B102			

Are the inspection results normal?

YES >> Replace the malfunctioning lamp.

NO >> Repair or replace the harness or connectors.

B121A FRONT FOG LAMP LH POWER SUPPLY CIRCUIT

< DTC/CIRCUIT DIAGNOSIS >

[LED HEADLAMP]

B121A FRONT FOG LAMP LH POWER SUPPLY CIRCUIT

DTC Logic

INFOID:0000000011421509

DTC DETECTION LOGIC

DTC	Display Item	Malfunction detected condition	Possible causes
B121A	FR FOG LAMP LH PWR SPLY CIRC [CIRC SHORT TO GROUND]	Short to ground	<ul style="list-style-type: none"> IPDM E/R Short to ground

DTC CONFIRMATION PROCEDURE

1. CHECK SELF DIAGNOSTIC RESULT

Ⓟ With CONSULT.

- Turn ignition switch ON.
- Perform "Self Diagnostic Result".

Is DTC B121A detected?

- YES >> Proceed to diagnosis procedure. Refer to [EXL-235, "Diagnosis Procedure"](#).
 NO >> Inspection End.

Diagnosis Procedure

INFOID:0000000011421510

1. CHECK FOG LAMP SHORT CIRCUIT TO GROUND

- Disconnect fog lamp connector and IPDM E/R connector.
- Check continuity between IPDM E/R harness connector and ground.

IPDM E/R		Ground	Continuity
Connector	Terminal		
E217	51		No

Is the inspection result normal?

- YES >> GO TO 2.
 NO >> Repair or replace harness.

2. CHECK FOG LAMP SHORT CIRCUIT TO GROUND

- Reconnect IPDM E/R connector.
- Check continuity between fog lamp harness connector and ground.

Fog lamp			Ground	Continuity
Connector	Terminal			
LH	E222	1		No

Is the inspection result normal?

- YES >> Refer to [GI-44, "Intermittent Incident"](#).
 NO >> Replace IPDM E/R. Refer to [PCS-40, "Removal and Installation"](#).

B1231 DAYTIME RUNNING LIGHT RH POWER SUPPLY CIRCUIT

< DTC/CIRCUIT DIAGNOSIS >

[LED HEADLAMP]

B1231 DAYTIME RUNNING LIGHT RH POWER SUPPLY CIRCUIT

DTC Logic

INFOID:000000011421511

DTC DETECTION LOGIC

DTC	Display Item	Malfunction detected condition	Possible causes
B1231	DTRL RH PWR SPLY CIRC [CIRC SHORT TO GRND]	When a short circuit to ground in the daytime running lamp circuit is detected.	<ul style="list-style-type: none">IPDM E/RShort to ground

DTC CONFIRMATION PROCEDURE

1.CHECK SELF DIAGNOSTIC RESULT

 With CONSULT.

- Turn ignition switch ON.
- Perform "Self Diagnostic Result".

Is DTC B1231 detected?

- YES >> Proceed to diagnosis procedure. Refer to [EXL-236, "Diagnosis Procedure"](#).
NO >> Inspection End.

Diagnosis Procedure

INFOID:000000011421512

1.CHECK FRONT COMBINATION LAMP SHORT CIRCUIT TO GROUND

- Disconnect front combination lamp connector and IPDM E/R connector.
- Check continuity between IPDM E/R harness connector and ground.

IPDM E/R		Ground	Continuity
Connector	Terminal		
E218	58		No

Is the inspection result normal?

- YES >> GO TO 2.
NO >> Repair or replace harness.

2.CHECK FRONT COMBINATION LAMP SHORT CIRCUIT TO GROUND

- Reconnect IPDM E/R connector.
- Check continuity between front combination lamp harness connector and ground.

Front combination lamp			Ground	Continuity
Connector	Terminal			
RH	E240	8		No

Is the inspection result normal?

- YES >> Refer to [GI-44, "Intermittent Incident"](#).
NO >> Replace IPDM E/R. Refer to [PCS-40, "Removal and Installation"](#).

B1256 FRONT FOG LAMP RH POWER SUPPLY CIRCUIT

< DTC/CIRCUIT DIAGNOSIS >

[LED HEADLAMP]

B1256 FRONT FOG LAMP RH POWER SUPPLY CIRCUIT

DTC Logic

INFOID:0000000011421513

DTC DETECTION LOGIC

DTC	Display Item	Malfunction detected condition	Possible causes
B1256	FR FOG LAMP RH PWR SPLY CIRC [CIRC SHORT TO GRND]	When a short circuit to ground is detected.	<ul style="list-style-type: none">• IPDM E/R• Short to ground

DTC CONFIRMATION PROCEDURE

1. CHECK SELF DIAGNOSTIC RESULT

Ⓟ With CONSULT.

1. Turn ignition switch ON.
2. Perform "Self Diagnostic Result".

Is DTC B1256 detected?

- YES >> Proceed to diagnosis procedure. Refer to [EXL-237, "Diagnosis Procedure"](#).
NO >> Inspection End.

Diagnosis Procedure

INFOID:0000000011421514

1. CHECK FOG LAMP SHORT CIRCUIT TO GROUND

1. Disconnect fog lamp connector and IPDM E/R connector.
2. Check continuity between IPDM E/R harness connector and ground.

IPDM E/R		Ground	Continuity
Connector	Terminal		
E218	57		No

Is the inspection result normal?

- YES >> GO TO 2.
NO >> Repair or replace harness.

2. CHECK FOG LAMP SHORT CIRCUIT TO GROUND

1. Reconnect IPDM E/R connector.
2. Check continuity between fog lamp harness connector and ground.

Fog lamp		Ground	Continuity
Connector	Terminal		
RH	E221	1	No

Is the inspection result normal?

- YES >> Refer to [GI-44, "Intermittent Incident"](#).
NO >> Replace IPDM E/R. Refer to [PCS-40, "Removal and Installation"](#).

B1C00 HEIGHT SENSOR POWER SUPPLY CIRCUIT

< DTC/CIRCUIT DIAGNOSIS >

[LED HEADLAMP]

B1C00 HEIGHT SENSOR POWER SUPPLY CIRCUIT

DTC Logic

INFOID:000000011280867

DTC DETECTION LOGIC

DTC	Display Item	Malfunction detected condition	Possible causes
B1C00	HEIGHT SENSOR PWR SPLY CIRC [CIRC SHORT TO GRND]	When the height sensor power supply circuit is shorted to supply power or shorted to ground	<ul style="list-style-type: none"> Short to ground Short to supply voltage
	HEIGHT SENSOR PWR SPLY CIRC [CIRC SHORT TO BATTERY]		

DTC CONFIRMATION PROCEDURE

1. CHECK SELF DIAGNOSTIC RESULT

Ⓜ With CONSULT.

- Turn ignition switch ON.
- Perform "Self Diagnostic Result".

Is DTC B1C00 detected?

- YES >> Proceed to diagnosis procedure. Refer to [EXL-238, "Diagnosis Procedure"](#).
 NO >> Inspection End.

Diagnosis Procedure

INFOID:000000011280868

1. CHECK HEIGHT SENSOR SHORT CIRCUIT TO GROUND

- Disconnect rear height sensor connector and IPDM E/R connector.
- Check continuity between IPDM E/R harness connector and ground.

IPDM E/R		Ground	Continuity
Connector	Terminal		
E120	25		No

Is the inspection result normal?

- YES >> GO TO 2.
 NO >> Repair or replace harness.

2. CHECK HEIGHT SENSOR SHORT CIRCUIT TO BATTERY VOLTAGE

- Reconnect IPDM E/R connector.
- Check the voltage between IPDM E/R harness connector and ground.

IPDM E/R		Ground	Voltage (Approx.)
Connector	Terminal		
E120	25		0 V

Is the inspection result normal?

- YES >> Refer to [GI-44, "Intermittent Incident"](#).
 NO >> Replace IPDM E/R. Refer to [PCS-40, "Removal and Installation"](#).

B1C02 REAR HEIGHT SENSOR SIGNAL

< DTC/CIRCUIT DIAGNOSIS >

[LED HEADLAMP]

B1C02 REAR HEIGHT SENSOR SIGNAL

DTC Logic

INFOID:000000011280869

DTC DETECTION LOGIC

DTC No.	Self-diagnosis item	DTC Detection Condition	Possible causes
B1C02	RR HEIGHT SENSOR SIGNAL [CIRC SHORT TO BATTERY]	<ul style="list-style-type: none"> Short to ground Short to supply voltage Circuit voltage out of range 	<ul style="list-style-type: none"> Harness or connectors between the rear height sensor and the IPDM E/R (The sensor circuit is open or shorted) IPDM E/R Height sensor
	RR HEIGHT SENSOR SIGNAL [CIRC SHORT TO GROUND OR OPEN]		
	RR HEIGHT SENSOR SIGNAL [CIRC VOLTAGE OUT OF RANGE]		

DTC CONFIRMATION PROCEDURE

1. CHECK SELF DIAGNOSTIC RESULT

- Turn ignition switch ON.
- Check "Self Diagnostic Result" with CONSULT.

Is DTC detected?

- YES >> Refer to [EXL-239, "Diagnosis Procedure"](#).
 NO >> Inspection End.

Diagnosis Procedure

INFOID:000000011280870

1. CHECK HEIGHT SENSOR SHORT CIRCUIT TO GROUND

- Disconnect rear height sensor connector and IPDM E/R connector.
- Check continuity between IPDM E/R harness connector and ground.

IPDM E/R		Ground	Continuity
Connector	Terminal		
E120	21		No

Is the inspection result normal?

- YES >> GO TO 2.
 NO >> Repair or replace harness.

2. CHECK HEIGHT SENSOR SHORT OPEN CIRCUIT

Check the continuity between IPDM E/R harness connector and height sensor connector.

IPDM E/R		Rear height sensor		Ground	Continuity
Connector	Terminal	Connector	Terminal		
E120	21	B91	1		Yes

Is the inspection result normal?

- YES >> GO TO 3.
 NO >> Repair or replace harness.

3. CHECK HEIGHT SENSOR SHORT CIRCUIT TO BATTERY VOLTAGE

- Reconnect IPDM E/R connector.
- Check the voltage between IPDM E/R harness connector and ground.

IPDM E/R		Ground	Voltage (Approx.)
Connector	Terminal		
E120	21		0 V

B1C02 REAR HEIGHT SENSOR SIGNAL

< DTC/CIRCUIT DIAGNOSIS >

[LED HEADLAMP]

Is the inspection result normal?

YES >> Refer to [GI-44, "Intermittent Incident"](#).

NO >> Replace IPDM E/R. Refer to [PCS-40, "Removal and Installation"](#).

B1C07 AIMING MOTOR DRIVE SIGNAL

< DTC/CIRCUIT DIAGNOSIS >

[LED HEADLAMP]

B1C07 AIMING MOTOR DRIVE SIGNAL

DTC Logic

INFOID:0000000011280871

DTC DETECTION LOGIC

DTC	Display Item	Malfunction detected condition	Possible causes
B1C07	AIMING MOTOR DRIVE SIGNAL [CIRC SHORT TO GRND]	<ul style="list-style-type: none"> DC motor circuit short to ground DC motor circuit short to supply voltage 	<ul style="list-style-type: none"> Front combination lamp harness IPDM E/R
	AIMING MOTOR DRIVE SIGNAL [CIRC SHORT TO BATTERY]		
	AIMING MOTOR DRIVE SIGNAL [SIGNAL COMPARE FAILURE]		

DTC CONFIRMATION PROCEDURE

1. CHECK SELF DIAGNOSTIC RESULT

Ⓜ With CONSULT.

- Turn ignition switch ON.
- Perform "Self Diagnostic Result".

Is DTC B1C07 detected?

- YES >> Proceed to diagnosis procedure. Refer to [EXL-241, "Diagnosis Procedure"](#).
 NO >> Inspection End.

Diagnosis Procedure

INFOID:0000000011280872

1. CHECK HEADLAMP AIMING MOTOR DRIVE SIGNAL SHORT CIRCUIT TO GROUND

- Disconnect LH and RH headlamp aiming motor connectors and IPDM E/R connector.
- Check continuity between IPDM E/R harness connector and ground.

IPDM E/R		Ground	Continuity
Connector	Terminal		
E218	64		No

Is the inspection result normal?

- YES >> GO TO 2.
 NO >> Repair or replace harness.

2. CHECK HEADLAMP AIMING MOTOR DRIVE SIGNAL SHORT CIRCUIT TO BATTERY VOLTAGE

Check the voltage between IPDM E/R harness connector and ground.

IPDM E/R		Ground	Voltage (Approx.)
Connector	Terminal		
E218	64		0 V

Is the inspection result normal?

- YES >> GO TO 3.
 NO >> Repair or replace harness.

3. CHECK HEADLAMP AIMING MOTOR DRIVE SIGNAL SHORT CIRCUIT TO BATTERY VOLTAGE

- Reconnect IPDM E/R connector.
- Check the voltage between IPDM E/R harness connector and ground.

IPDM E/R		Ground	Voltage (Approx.)
Connector	Terminal		
E218	64		0 V

A
B
C
D
E
F
G
H
I
J
K
EXL
M
N
O
P

B1C07 AIMING MOTOR DRIVE SIGNAL

< DTC/CIRCUIT DIAGNOSIS >

[LED HEADLAMP]

Is the inspection result normal?

YES >> Refer to [GI-44, "Intermittent Incident"](#).

NO >> Replace IPDM E/R. Refer to [PCS-40, "Removal and Installation"](#).

B20CB DAYTIME RUNNING LIGHT LH POWER SUPPLY CIRCUIT

< DTC/CIRCUIT DIAGNOSIS >

[LED HEADLAMP]

B20CB DAYTIME RUNNING LIGHT LH POWER SUPPLY CIRCUIT

DTC Logic

INFOID:0000000011421515

DTC DETECTION LOGIC

DTC	Display Item	Malfunction detected condition	Possible causes
B02CB	DTRL LH PWR SPLY CIRC [CIRC SHORT TO GRND]	When a short circuit to ground is detected.	<ul style="list-style-type: none">IPDM E/RShort to ground

DTC CONFIRMATION PROCEDURE

1. CHECK SELF DIAGNOSTIC RESULT

 With CONSULT.

1. Turn ignition switch ON.

2. Perform "Self Diagnostic Result".

Is DTC B02CB detected?

YES >> Proceed to diagnosis procedure. Refer to [EXL-243, "Diagnosis Procedure"](#).

NO >> Inspection End.

Diagnosis Procedure

INFOID:0000000011421516

1. CHECK FRONT COMBINATION LAMP SHORT CIRCUIT TO GROUND

1. Disconnect front combination lamp connector and IPDM E/R connector.

2. Check continuity between IPDM E/R harness connector and ground.

IPDM E/R		Ground	Continuity
Connector	Terminal		
E217	49		No

Is the inspection result normal?

YES >> GO TO 2.

NO >> Repair or replace harness.

2. CHECK FRONT COMBINATION LAMP SHORT CIRCUIT TO GROUND

1. Reconnect IPDM E/R connector.

2. Check continuity between fog lamp harness connector and ground.

Front combination lamp			Ground	Continuity
Connector	Terminal			
LH	E239	8		No

Is the inspection result normal?

YES >> Refer to [GI-44, "Intermittent Incident"](#).

NO >> Replace IPDM E/R. Refer to [PCS-40, "Removal and Installation"](#).

B20CE HEADLAMP (HI) LH POWER SUPPLY CIRCUIT

< DTC/CIRCUIT DIAGNOSIS >

[LED HEADLAMP]

B20CE HEADLAMP (HI) LH POWER SUPPLY CIRCUIT

DTC Logic

INFOID:000000011280875

DTC DETECTION LOGIC

DTC	Display Item	Malfunction detected condition	Possible causes
B20CE	DTRL LH PWR SPLY CIRC [CIRC SHORT TO GRND]	Short to ground	<ul style="list-style-type: none">IPDM E/RShort to ground

DTC CONFIRMATION PROCEDURE

1.CHECK SELF DIAGNOSTIC RESULT

 With CONSULT.

- Turn ignition switch ON.
- Perform "Self Diagnostic Result".

Is DTC B20CE detected?

- YES >> Proceed to diagnosis procedure. Refer to [EXL-244, "Diagnosis Procedure"](#).
NO >> Inspection End.

Diagnosis Procedure

INFOID:000000011280876

1.CHECK HEAD LAMP SHORT CIRCUIT TO GROUND

- Disconnect front combination lamp connector and IPDM E/R connector.
- Check continuity between IPDM E/R harness connector and ground.

IPDM E/R		Ground	Continuity
Connector	Terminal		
E218	59		No

Is the inspection result normal?

- YES >> GO TO 2.
NO >> Repair or replace harness.

2.CHECK HEAD LAMP SHORT CIRCUIT TO GROUND

- Reconnect IPDM E/R connector.
- Check continuity between front combination lamp harness connector and ground.

Front combination lamp			Ground	Continuity
Connector		Terminal		
LH	E239	5		No

Is the inspection result normal?

- YES >> Refer to [GI-44, "Intermittent Incident"](#).
NO >> Replace IPDM E/R. Refer to [PCS-40, "Removal and Installation"](#).

B20CF HEADLAMP (HI) RH POWER SUPPLY CIRCUIT

< DTC/CIRCUIT DIAGNOSIS >

[LED HEADLAMP]

B20CF HEADLAMP (HI) RH POWER SUPPLY CIRCUIT

DTC Logic

INFOID:000000011280877

DTC DETECTION LOGIC

DTC	Display Item	Malfunction detected condition	Possible causes
B20CF	HL (HI) RH PWR SPLY CIRC [CIRC SHORT TO GRND]	Short to ground	<ul style="list-style-type: none"> IPDM E/R Short to ground

DTC CONFIRMATION PROCEDURE

1.CHECK SELF DIAGNOSTIC RESULT

 With CONSULT.

1. Turn ignition switch ON.

2. Perform "Self Diagnostic Result".

Is DTC B20CF detected?

YES >> Proceed to diagnosis procedure. Refer to [EXL-245, "Diagnosis Procedure"](#).

NO >> Inspection End.

Diagnosis Procedure

INFOID:000000011280878

1.CHECK HEAD LAMP SHORT CIRCUIT TO GROUND

1. Disconnect front combination lamp connector and IPDM E/R connector.

2. Check continuity between IPDM E/R harness connector and ground.

IPDM E/R		Ground	Continuity
Connector	Terminal		
E217	54		No

Is the inspection result normal?

YES >> GO TO 2.

NO >> Repair or replace harness.

2.CHECK HEAD LAMP SHORT CIRCUIT TO GROUND

1. Reconnect IPDM E/R connector.

2. Check continuity between front combination lamp harness connector and ground.

Front combination lamp			Ground	Continuity
Connector	Terminal			
RH	E240	5		No

Is the inspection result normal?

YES >> Refer to [GI-44, "Intermittent Incident"](#).

NO >> Replace IPDM E/R. Refer to [PCS-40, "Removal and Installation"](#).

B20D0 HEADLAMP (LO) LH POWER SUPPLY CIRCUIT

< DTC/CIRCUIT DIAGNOSIS >

[LED HEADLAMP]

B20D0 HEADLAMP (LO) LH POWER SUPPLY CIRCUIT

DTC Logic

INFOID:000000011280879

DTC DETECTION LOGIC

DTC	Display Item	Malfunction detected condition	Possible causes
B20D0	HI (LO) RH PWR SPLY CIRC [CIRC SHORT TO GRND]	Short to ground	<ul style="list-style-type: none">IPDM E/RShort to ground

DTC CONFIRMATION PROCEDURE

1.CHECK SELF DIAGNOSTIC RESULT

④ With CONSULT.

- Turn ignition switch ON.
- Perform "Self Diagnostic Result".

Is DTC B20D0 detected?

- YES >> Proceed to diagnosis procedure. Refer to [EXL-246, "Diagnosis Procedure"](#).
NO >> Inspection End.

Diagnosis Procedure

INFOID:000000011280880

1.CHECK FRONT COMBINATION LAMP SHORT CIRCUIT TO GROUND

- Disconnect front combination lamp connector and IPDM E/R connector.
- Check continuity between IPDM E/R harness connector and ground.

IPDM E/R		Ground	Continuity
Connector	Terminal		
E217	50		No

Is the inspection result normal?

- YES >> GO TO 2.
NO >> Repair or replace harness.

2.CHECK FRONT COMBINATION LAMP SHORT CIRCUIT TO GROUND

- Reconnect IPDM E/R connector.
- Check continuity between front combination lamp harness connector and ground.

Front combination lamp			Ground	Continuity
Connector		Terminal		
LH	E239	6		No

Is the inspection result normal?

- YES >> Refer to [GI-44, "Intermittent Incident"](#).
NO >> Replace IPDM E/R. Refer to [PCS-40, "Removal and Installation"](#).

B20D1 HEADLAMP (LO) RH POWER SUPPLY CIRCUIT

< DTC/CIRCUIT DIAGNOSIS >

[LED HEADLAMP]

B20D1 HEADLAMP (LO) RH POWER SUPPLY CIRCUIT

DTC Logic

INFOID:000000011280881

DTC DETECTION LOGIC

DTC	Display Item	Malfunction detected condition	Possible causes
B20D1	HL (LO) RH PWR SPLY CIRC [CIRC SHORT TO GRND]	Short to ground	<ul style="list-style-type: none"> IPDM E/R Short to ground

DTC CONFIRMATION PROCEDURE

1.CHECK SELF DIAGNOSTIC RESULT

 With CONSULT.

1. Turn ignition switch ON.

2. Perform "Self Diagnostic Result".

Is DTC B20D1 detected?

YES >> Proceed to diagnosis procedure. Refer to [EXL-247, "Diagnosis Procedure"](#).

NO >> Inspection End.

Diagnosis Procedure

INFOID:000000011280882

1.CHECK FRONT COMBINATION LAMP SHORT CIRCUIT TO GROUND

1. Disconnect front combination lamp connector and IPDM E/R connector.

2. Check continuity between IPDM E/R harness connector and ground.

IPDM E/R		Ground	Continuity
Connector	Terminal		
E218	62		No

Is the inspection result normal?

YES >> GO TO 2.

NO >> Repair or replace harness.

2.CHECK FRONT COMBINATION LAMP SHORT CIRCUIT TO GROUND

1. Reconnect IPDM E/R connector.

2. Check continuity between front combination lamp harness connector and ground.

Front combination lamp			Ground	Continuity
Connector	Terminal			
RH	E240	6		No

Is the inspection result normal?

YES >> Refer to [GI-44, "Intermittent Incident"](#).

NO >> Replace IPDM E/R. Refer to [PCS-40, "Removal and Installation"](#).

B20D2 PARKING LAMP POWER SUPPLY CIRCUIT

< DTC/CIRCUIT DIAGNOSIS >

[LED HEADLAMP]

B20D2 PARKING LAMP POWER SUPPLY CIRCUIT

DTC Logic

INFOID:000000011429396

DTC DETECTION LOGIC

DTC	Display Item	Malfunction detected condition	Possible causes
B20D2	PARKING LAMP PWR SPLY CIRC [CIRC SHORT TO GROUND]	When a short to ground is detected in the parking lamp power supply circuit.	• Short to ground

DTC CONFIRMATION PROCEDURE

1. CHECK SELF DIAGNOSTIC RESULT

Ⓜ With CONSULT.

1. Turn ignition switch ON.
2. Perform "Self Diagnostic Result".

Is DTC B20D2 detected?

- YES >> Proceed to diagnosis procedure. Refer to [EXL-248, "Diagnosis Procedure"](#).
NO >> Inspection End.

Diagnosis Procedure

INFOID:000000011429397

1. CHECK FRONT COMBINATION LAMP SHORT CIRCUIT TO GROUND

1. Disconnect front combination lamp connectors and IPDM E/R connector.
2. Check continuity between IPDM E/R harness connector and ground.

IPDM E/R			Ground	Continuity
Connector		Terminal		
LH		E217	Ground	No
		56		
RH		E218		
		61		

Is the inspection result normal?

- YES >> GO TO 2.
NO >> Repair or replace harness.

2. CHECK FRONT COMBINATION LAMP SHORT CIRCUIT TO GROUND

1. Reconnect IPDM E/R connector.
2. Check continuity between front combination lamp harness connector and ground.

IPDM E/R			Ground	Continuity
Connector		Terminal		
LH	E236 (parking lamp)	12	Ground	No
	E235 (side marker lamp)	9		
RH	E234 (parking lamp)	12		
	E233 (side marker lamp)	9		

Is the inspection result normal?

- YES >> Refer to [GI-44, "Intermittent Incident"](#).
NO >> Replace IPDM E/R. Refer to [PCS-40, "Removal and Installation"](#).

B20D4 TAIL LAMP LH POWER SUPPLY CIRCUIT

< DTC/CIRCUIT DIAGNOSIS >

[LED HEADLAMP]

B20D4 TAIL LAMP LH POWER SUPPLY CIRCUIT

DTC Logic

INFOID:000000011280885

DTC DETECTION LOGIC

DTC	Display Item	Malfunction detected condition	Possible causes
B20D4	TAIL LAMP LH PWR SPLY CIRC [CIRC SHORT TO GRND]	Short to ground	<ul style="list-style-type: none"> IPDM E/R Short to ground

DTC CONFIRMATION PROCEDURE

1. CHECK SELF DIAGNOSTIC RESULT

Ⓜ With CONSULT.

- Turn ignition switch ON.
- Perform "Self Diagnostic Result".

Is DTC B20D4 detected?

- YES >> Proceed to diagnosis procedure. Refer to [EXL-249, "Diagnosis Procedure"](#).
 NO >> Inspection End.

Diagnosis Procedure

INFOID:000000011280886

1. CHECK TAIL LAMP SHORT CIRCUIT TO GROUND

- Disconnect rear combination lamp (LH), license plate lamps, back up lamp connectors and IPDM E/R connector.
- Check continuity between IPDM E/R harness connector and ground.

IPDM E/R		Ground	Continuity
Connector	Terminal		
E119	4		No

Is the inspection result normal?

- YES >> GO TO 2.
 NO >> Repair or replace harness.

2. CHECK TAIL LAMP SHORT CIRCUIT TO GROUND

- Reconnect IPDM E/R connector.
- Check continuity between rear combination lamp harness connector and ground.

Rear combination lamp			Ground	Continuity
Connector	Terminal			
LH	B90	1		No

Is the inspection result normal?

- YES >> Refer to [GI-44, "Intermittent Incident"](#).
 NO >> Replace IPDM E/R. Refer to [PCS-40, "Removal and Installation"](#).

B20D5 TAIL LAMP RH POWER SUPPLY CIRCUIT

< DTC/CIRCUIT DIAGNOSIS >

[LED HEADLAMP]

B20D5 TAIL LAMP RH POWER SUPPLY CIRCUIT

DTC Logic

INFOID:000000011280887

DTC DETECTION LOGIC

DTC	Display Item	Malfunction detected condition	Possible causes
B20D5	TAIL LAMP RH PWR SPLY CIRC [CIRC SHORT TO GRND]	When a short circuit to ground is detected in the tail lamp supply voltage circuit.	<ul style="list-style-type: none">• IPDM E/R• Short to ground

DTC CONFIRMATION PROCEDURE

1. CHECK SELF DIAGNOSTIC RESULT

 With CONSULT.

1. Turn ignition switch ON.
2. Perform "Self Diagnostic Result".

Is DTC B20D5 detected?

- YES >> Proceed to diagnosis procedure. Refer to [EXL-250, "Diagnosis Procedure"](#).
NO >> Inspection End.

Diagnosis Procedure

INFOID:000000011280888

1. CHECK TAIL LAMP SHORT CIRCUIT TO GROUND

1. Disconnect rear combination lamp (RH), back up lamp connectors and IPDM E/R connector.
2. Check continuity between IPDM E/R harness connector and ground.

IPDM E/R		Ground	Continuity
Connector	Terminal		
E119	17		No

Is the inspection result normal?

- YES >> GO TO 2.
NO >> Repair or replace harness.

2. CHECK TAIL LAMP SHORT CIRCUIT TO GROUND

1. Reconnect IPDM E/R connector.
2. Check continuity between rear combination lamp harness connector and ground.

Rear combination lamp			Ground	Continuity
Connector		Terminal		
RH	B102	1		No

Is the inspection result normal?

- YES >> Refer to [GI-44, "Intermittent Incident"](#).
NO >> Replace IPDM E/R. Refer to [PCS-40, "Removal and Installation"](#).

B20DB HEIGHT SENSOR INITIALIZE NOT DONE

< DTC/CIRCUIT DIAGNOSIS >

[LED HEADLAMP]

B20DB HEIGHT SENSOR INITIALIZE NOT DONE

DTC Logic

INFOID:0000000011280889

DTC DETECTION LOGIC

DTC	Display Item	DTC detection condition	Possible causes
B20DB	HEIGHT SENS INITIALIZE NOT DONE [MISSING CALIBRATION]	Sensor initialization is not complete.	<ul style="list-style-type: none">• Incomplete sensor initialization.• Rear height sensor
	HEIGHT SENS INITIALIZE NOT DONE [NOT CONFIGURED]		

DTC CONFIRMATION PROCEDURE

1.PERFORM SELF DIAGNOSTIC RESULT

CONSULT

1. Turn ignition switch ON.
2. Perform "Self Diagnostic Result" of IPDM E/R using CONSULT.

Is DTC B20DB detected?

- YES >> Refer to [EXL-251, "Diagnosis Procedure"](#).
NO >> Inspection End.

Diagnosis Procedure

INFOID:0000000011280890

1.CHECK SELF DIAGNOSTIC RESULT

With CONSULT.

1. Turn ignition ON.
2. Select "SENSOR INITIALIZE" in "Work support" of "IPDM E/R".

Is DTC B20DB detected?

- YES >> Replace IPDM E/R. Refer to [PCS-40, "Removal and Installation"](#).
NO >> Inspection End.

A
B
C
D
E
F
G
H
I
J
K

EXL

M
N
O
P

B20E2 LED HEADLAMP RH

< DTC/CIRCUIT DIAGNOSIS >

[LED HEADLAMP]

B20E2 LED HEADLAMP RH

DTC Logic

INFOID:000000011280891

DTC DETECTION LOGIC

DTC No.	Self-diagnosis item	DTC Detection Condition	Possible causes
B20E2	LED HEADLAMP RH [CMPNENT INTERNAL MLFNCTN]	Detection signal circuit short to ground.	<ul style="list-style-type: none">• Harness or connectors between the front combination lamp RH and the IPDM E/R• IPDM E/R

DTC CONFIRMATION PROCEDURE

1.SELF DIAGNOSTIC RESULT

1. Turn ignition switch ON.
2. Check "Self Diagnostic Result" with CONSULT.

Is DTC detected?

- YES >> Refer to [EXL-252, "Diagnosis Procedure"](#).
NO >> Inspection End.

Diagnosis Procedure

INFOID:000000011280892

1.CHECK FRONT COMBINATION LAMP RH SHORT CIRCUIT TO GROUND

1. Disconnect front combination lamp RH connector and IPDM E/R connector.
2. Check continuity between IPDM E/R harness connector and ground.

IPDM E/R		Ground	Continuity
Connector	Terminal		
E218	60		No

Is the inspection result normal?

- YES >> GO TO 2.
NO >> Repair or replace harness.

2.CHECK FRONT COMBINATION LAMP RH SHORT CIRCUIT TO GROUND

1. Reconnect IPDM E/R connector.
2. Check continuity between front combination lamp RH harness connector and ground.

Front combination lamp RH		Ground	Ground
Connector	Terminal		
E240	7		No

Is the inspection result normal?

- YES >> Replace front combination lamp RH. Refer to [EXL-266, "Removal and Installation"](#).
NO >> Replace IPDM E/R. Refer to [PCS-40, "Removal and Installation"](#).

B20E3 LED HEADLAMP LH

< DTC/CIRCUIT DIAGNOSIS >

[LED HEADLAMP]

B20E3 LED HEADLAMP LH

DTC Logic

INFOID:000000011280893

DTC DETECTION LOGIC

DTC No.	Self-diagnosis item	DTC Detection Condition	Possible causes
B20E3	LED HEADLAMP LH [CMPNENT INTERNAL MLFNCTN]	Detection signal circuit short to ground	<ul style="list-style-type: none"> • Harness or connectors between the front combination lamp LH and the IPDM E/R • IPDM E/R

DTC CONFIRMATION PROCEDURE

1.SELF DIAGNOSTIC RESULT

1. Turn ignition switch ON.
2. Check "Self Diagnostic Result" with CONSULT.

Is DTC detected?

- YES >> Refer to [EXL-253, "Diagnosis Procedure"](#).
 NO >> Inspection End.

Diagnosis Procedure

INFOID:000000011280894

1.CHECK FRONT COMBINATION LAMP LH SHORT CIRCUIT TO GROUND

1. Disconnect front combination lamp LH connector and IPDM E/R connector.
2. Check continuity between IPDM E/R harness connector and ground.

IPDM E/R		Ground	Continuity
Connector	Terminal		
E217	53		No

Is the inspection result normal?

- YES >> GO TO 2.
 NO >> Repair or replace harness.

2.CHECK FRONT COMBINATION LAMP LH SHORT CIRCUIT TO GROUND

1. Reconnect IPDM E/R connector.
2. Check continuity between front combination lamp LH harness connector and ground.

Front combination lamp LH		Ground	Ground
Connector	Terminal		
E239	7		No

Is the inspection result normal?

- YES >> Replace front combination lamp LH. Refer to [EXL-266, "Removal and Installation"](#).
 NO >> Replace IPDM E/R. Refer to [PCS-40, "Removal and Installation"](#).

EXTERIOR LIGHTING SYSTEM SYMPTOMS

< SYMPTOM DIAGNOSIS >

[LED HEADLAMP]

SYMPTOM DIAGNOSIS

EXTERIOR LIGHTING SYSTEM SYMPTOMS

Symptom Table

INFOID:0000000011280895

CAUTION:

Perform the “Self Diagnostic Result” with CONSULT before the symptom diagnosis. Perform the trouble diagnosis if any DTC is detected.

Symptom		Possible cause	Inspection item
Headlamp (HI) is not turned ON.	One side	<ul style="list-style-type: none"> • Fuse • LED • Harness between IPDM E/R and headlamp (HI) • Harness between headlamp (HI) and ground • IPDM E/R 	Headlamp (HI) circuit Refer to EXL-244, "DTC Logic" (LH) or EXL-245, "DTC Logic" (RH).
	Both sides	<p>Symptom diagnosis “BOTH SIDE HEADLAMPS (HI) ARE NOT TURNED ON” Refer to EXL-244, "DTC Logic" (LH) or EXL-245, "DTC Logic" (RH).</p>	
High beam indicator lamp is not turned ON. [Headlamp (HI) is turned ON.]		Combination meter	<ul style="list-style-type: none"> • Combination meter “Data Monitor” “HI-BEAM IND” • BCM (HEAD LAMP) “Active Test” “HEADLAMP”
Headlamp (LO) is not turned ON.	One side	<ul style="list-style-type: none"> • Fuse • LED • Harness between IPDM E/R and headlamp lamp (LO) • Harness between headlamp (LO) and ground • IPDM E/R 	Headlamp (LO) circuit Refer to EXL-246, "DTC Logic" (LH) or EXL-247, "DTC Logic" (RH).
	Both sides	<p>Symptom diagnosis “BOTH SIDE HEADLAMPS (LO) ARE NOT TURNED ON” Refer to EXL-246, "DTC Logic" (LH) or EXL-247, "DTC Logic" (RH).</p>	
Each lamp is not turned ON/OFF with lighting switch AUTO.		<ul style="list-style-type: none"> • Combination switch • Harness between combination switch and BCM • BCM 	Combination switch Refer to BCS-73, "Symptom Table" (with Intelligent Key system) or BCS-133, "Symptom Table" (without Intelligent Key system).
		<ul style="list-style-type: none"> • Optical sensor • Harness between optical sensor and BCM • BCM 	Optical sensor Refer to EXL-87, "Component Function Check" .
Daytime running light is not turned ON. [Headlamp (HI) is turned ON.]		<ul style="list-style-type: none"> • Fuse • Harness between IPDM E/R and front combination lamp • IPDM E/R • BCM • ECM • Combination meter 	<ul style="list-style-type: none"> • Daytime running light circuit Refer to EXL-236, "DTC Logic". • BCM (HEADLAMP) “Data Monitor” “ENGINE STATE” • Combination meter “Data Monitor” “PKB SW” • BCM (HEADLAMP) “Active Test” “DAYTIME RUNNING LIGHT”
Parking lamp is not turned ON.		<ul style="list-style-type: none"> • Fuse • Parking lamp bulb • Harness between IPDM E/R and front combination lamp • IPDM E/R 	Parking lamp circuit Refer to EXL-248, "DTC Logic" .

EXTERIOR LIGHTING SYSTEM SYMPTOMS

< SYMPTOM DIAGNOSIS >

[LED HEADLAMP]

Symptom		Possible cause	Inspection item
Front side marker lamp is not turned ON.		<ul style="list-style-type: none"> • Front side marker lamp bulb • Harness between IPDM E/R and front side marker lamp • Harness between front side marker lamp and ground • IPDM E/R 	Front side marker lamp circuit Refer to EXL-248, "DTC Logic" .
License plate lamp is not turned ON.		<ul style="list-style-type: none"> • License plate lamp bulb • Harness between IPDM E/R and license plate lamp • Harness between license plate lamp and ground 	License plate lamp circuit Refer to EXL-249, "DTC Logic" .
Parking lamp, side marker lamp, tail lamp and license plate lamp are not turned ON.		Symptom diagnosis "PARKING, SIDE MARKER, LICENSE PLATE AND TAIL LAMPS ARE NOT TURNED ON" Refer to EXL-259, "Description" .	
Tail lamp indicator is not turned ON. (Exterior lamps are turned ON.)		Combination meter	<ul style="list-style-type: none"> • Combination meter "Data Monitor" "LIGHT IND" • BCM (HEADLAMP) "Active Test" "TAIL LAMP"
Turn signal lamp does not blink.	Indicator lamp is normal. (Applicable side performs high flasher activation.)	<ul style="list-style-type: none"> • Turn signal lamp bulb • Door mirror • Harness between BCM and each turn signal lamp • Harness between each turn signal lamp and ground 	Turn signal lamp circuit Refer to EXL-231, "Component Function Check" .
Turn signal indicator lamp does not blink. (Turn signal lamp is normal.)	One side	Combination meter	—
	Both sides (Always)	<ul style="list-style-type: none"> • Turn signal indicator lamp signal • BCM • Combination meter 	<ul style="list-style-type: none"> • Combination meter "Data Monitor" "TURN IND" • BCM (FLASHER) "Active Test" "FLASHER"
	Both sides (Only when activating hazard warning lamp with ignition switch OFF)	<ul style="list-style-type: none"> • Combination meter power supply and ground circuit • Combination meter 	Combination meter Power supply and ground circuit Refer to MWI-60, "COMBINATION METER : Diagnosis Procedure" .
<ul style="list-style-type: none"> • Hazard warning lamp does not activate. • Hazard warning lamp continues activating. (Turn signal is normal.) 		<ul style="list-style-type: none"> • Hazard switch • Harness between hazard switch and BCM • Harness between hazard switch and ground • BCM 	Hazard switch circuit Refer to EXL-90, "Component Function Check" .
Front fog lamp is not turned ON.	One side	<ul style="list-style-type: none"> • Front fog lamp bulb • Harness between IPDM E/R and front fog lamp • Harness between front fog lamp and ground • IPDM E/R 	Front fog lamp circuit Refer to EXL-235, "DTC Logic" (LH) or EXL-237, "DTC Logic" (RH).
	Both sides	Symptom diagnosis "BOTH SIDE FRONT FOG LAMPS ARE NOT TURNED ON" Refer to EXL-235, "DTC Logic" (LH) or EXL-237, "DTC Logic" (RH).	

A
B
C
D
E
F
G
H
I
J
K
M
N
O
P

EXL

NORMAL OPERATING CONDITION

< SYMPTOM DIAGNOSIS >

[LED HEADLAMP]

NORMAL OPERATING CONDITION

Description

INFOID:000000011280896

AUTO LIGHT SYSTEM

The headlamp may not be turned ON/OFF immediately after passing dark area or bright area (short tunnel, sky bridge, shadowed area, etc.) while using the auto light system. This is caused by the control difference. This is normal.

BOTH SIDE HEADLAMPS (HI) ARE NOT TURNED ON

< SYMPTOM DIAGNOSIS >

[LED HEADLAMP]

BOTH SIDE HEADLAMPS (HI) ARE NOT TURNED ON

Description

INFOID:0000000011280897

Both side headlamps (HI) are not turned ON when setting to the lighting switch HI or PASS.

Diagnosis Procedure

INFOID:0000000011280898

1.COMBINATION SWITCH INSPECTION

Check combination switch. Refer to [BCS-73. "Symptom Table"](#) (with Intelligent Key system) or [BCS-133. "Symptom Table"](#) (without Intelligent Key system).

Is the inspection result normal?

YES >> GO TO 2.

NO >> Repair or replace the malfunctioning part.

2.CHECK HEADLAMP (HI) REQUEST SIGNAL INPUT

CONSULT DATA MONITOR

1. Select "HEADLAMP (HI)" in "Data Monitor" of "IPDM E/R".
2. With operating the lighting switch, check the monitor status.

Monitor item	Condition		Monitor status
HEADLAMP (HI)	Lighting switch (2ND)	HI or PASS	On
		LO	Off

Is the inspection result normal?

YES >> GO TO 3.

NO >> Replace BCM. Refer to [BCS-75. "Removal and Installation"](#) (with Intelligent Key system) or [BCS-135. "Removal and Installation"](#) (without Intelligent Key system).

3.HEADLAMP (HI) CIRCUIT INSPECTION

Check headlamp (HI) circuit. Refer to [EXL-244. "DTC Logic"](#) (LH) or [EXL-245. "DTC Logic"](#) (RH).

Is the inspection result normal?

YES >> Refer to [GI-44. "Intermittent Incident"](#).

NO >> Repair or replace the malfunctioning part.

A
B
C
D
E
F
G
H
I
J
K
L
M
N
O
P

EXL

BOTH SIDE HEADLAMPS (LO) ARE NOT TURNED ON

< SYMPTOM DIAGNOSIS >

[LED HEADLAMP]

BOTH SIDE HEADLAMPS (LO) ARE NOT TURNED ON

Description

INFOID:000000011280899

Both side headlamps (LO) are not turned ON in any condition.

Diagnosis Procedure

INFOID:000000011280900

1. CHECK COMBINATION SWITCH

Check combination switch. Refer to [BCS-73, "Symptom Table"](#) (with Intelligent Key system) or [BCS-133, "Symptom Table"](#) (without Intelligent Key system).

Is the inspection result normal?

YES >> GO TO 2.

NO >> Repair or replace the malfunctioning part.

2. CHECK HEADLAMP (LO) REQUEST SIGNAL INPUT

CONSULT DATA MONITOR

1. Select "HEADLAMP (LO)" in "Data Monitor" of "IPDM E/R".
2. With operating the lighting switch, check the monitor status.

Monitor item	Condition		Monitor status
HEADLAMP (LO)	Lighting switch	2ND	On
		OFF	Off

Is the inspection result normal?

YES >> GO TO 3.

NO >> Replace BCM. Refer to [BCS-75, "Removal and Installation"](#) (with Intelligent Key system) or [BCS-135, "Removal and Installation"](#) (without Intelligent Key system).

3. HEADLAMP (LO) CIRCUIT INSPECTION

Check headlamp (LO) circuit. Refer to [EXL-246, "DTC Logic"](#) (LH) or [EXL-247, "DTC Logic"](#) (RH).

Is the inspection result normal?

YES >> Refer to [GI-44, "Intermittent Incident"](#).

NO >> Repair or replace the malfunctioning part.

PARKING, LICENSE PLATE, SIDE MARKER AND TAIL LAMPS ARE NOT TURNED ON

< SYMPTOM DIAGNOSIS >

[LED HEADLAMP]

PARKING, LICENSE PLATE, SIDE MARKER AND TAIL LAMPS ARE NOT TURNED ON

Description

INFOID:000000011280901

The parking, license plate, side marker, tail lamps and each illumination are not turned ON in any condition.

Diagnosis Procedure

INFOID:000000011280902

1.COMBINATION SWITCH INSPECTION

Check combination switch. Refer to [BCS-73, "Symptom Table"](#) (with Intelligent Key system) or [BCS-133, "Symptom Table"](#) (without Intelligent Key system).

Is the combination switch normal?

YES >> GO TO 2.

NO >> Repair or replace the malfunctioning part.

2.CHECK TAIL LAMP REQUEST SIGNAL INPUT

CONSULT DATA MONITOR

1. Select "TAIL LAMP" in "Data Monitor" of "IPDM E/R".
2. With operating the lighting switch, check the monitor status.

Monitor item	Condition		Monitor status
TAIL LAMP	Lighting switch	1ST	On
		OFF	Off

Is the inspection result normal?

YES >> Replace IPDM E/R. Refer to [PCS-40, "Removal and Installation"](#).

NO >> Replace BCM. Refer to [BCS-75, "Removal and Installation"](#) (with Intelligent Key system) or [BCS-135, "Removal and Installation"](#) (without Intelligent Key system).

A
B
C
D
E
F
G
H
I
J
K
EXL
M
N
O
P

BOTH SIDE FRONT FOG LAMPS ARE NOT TURNED ON

< SYMPTOM DIAGNOSIS >

[LED HEADLAMP]

BOTH SIDE FRONT FOG LAMPS ARE NOT TURNED ON

Description

INFOID:000000011280903

The front fog lamps are not turned ON in any condition.

Diagnosis Procedure

INFOID:000000011280904

1. CHECK COMBINATION SWITCH

Check combination switch. Refer to [BCS-73, "Symptom Table"](#) (with Intelligent Key system) or [BCS-133, "Symptom Table"](#) (without Intelligent Key system).

Is the inspection result normal?

YES >> GO TO 3.

NO >> Repair or replace the malfunctioning part.

2. CHECK FRONT FOG LAMP REQUEST SIGNAL INPUT

④ CONSULT DATA MONITOR

1. Select "FRONT FOG LAMP REQ" in "Data Monitor" of "IPDM E/R".
2. With operating the front fog lamp switch, check the monitor status.

Monitor item	Condition	Monitor status
FRONT FOG LAMP REQ	Front fog lamp switch (With lighting switch 2ND)	ON
		OFF
		On
		Off

Is the item status normal?

YES >> Replace IPDM E/R. Refer to [PCS-40, "Removal and Installation"](#).

NO >> Replace BCM. Refer to [BCS-75, "Removal and Installation"](#) (with Intelligent Key system) or [BCS-135, "Removal and Installation"](#) (without Intelligent Key system).

HEADLAMP AIMING ADJUSTMENT

< PERIODIC MAINTENANCE >

[LED HEADLAMP]

PERIODIC MAINTENANCE

HEADLAMP AIMING ADJUSTMENT

Inspection

INFOID:000000011280905

PREPARATION BEFORE ADJUSTING

Before performing aiming adjustment, check the following:

- Make sure all tires are inflated to correct pressure.
- Place vehicle and screen on level surface.
- Make sure there is no load in vehicle other than the driver (or equivalent weight placed in driver's position).
- Coolant and engine oil filled to correct level, and fuel tank full.
- Remove cargo and/or luggage to maintain an unloaded vehicle condition.
- Confirm spare tire, jack and tools are properly stowed.
- Carefully wipe off any dirt from headlamp lens.

CAUTION:

Do not use organic solvent (thinner, gasoline etc.)

- Place a driver or equivalent weight of 68.5 kg (150 lb) on the driver seat.
- By hand, bounce the front and rear of the vehicle to settle the suspension and eliminate any static load.
- Place the front tires in the straight ahead position.
- Aim each headlamp individually and ensure other headlamp beam pattern is blocked from screen.

NOTE:

- For headlamp aiming details, refer to regulations in your area.
- By regulation, no means for horizontal aim adjustment is provided from the factory; only vertical aim is adjustable.
- Use adjusting screw to perform aiming adjustment.
- Perform headlamp aiming if:
 - The vehicle front body has been repaired;
 - The front combination lamp has been removed or replaced;
 - Any outfitting has been installed;
 - The vehicle's standard load condition has been substantially increased.

AIMING ADJUSTMENT SCREW

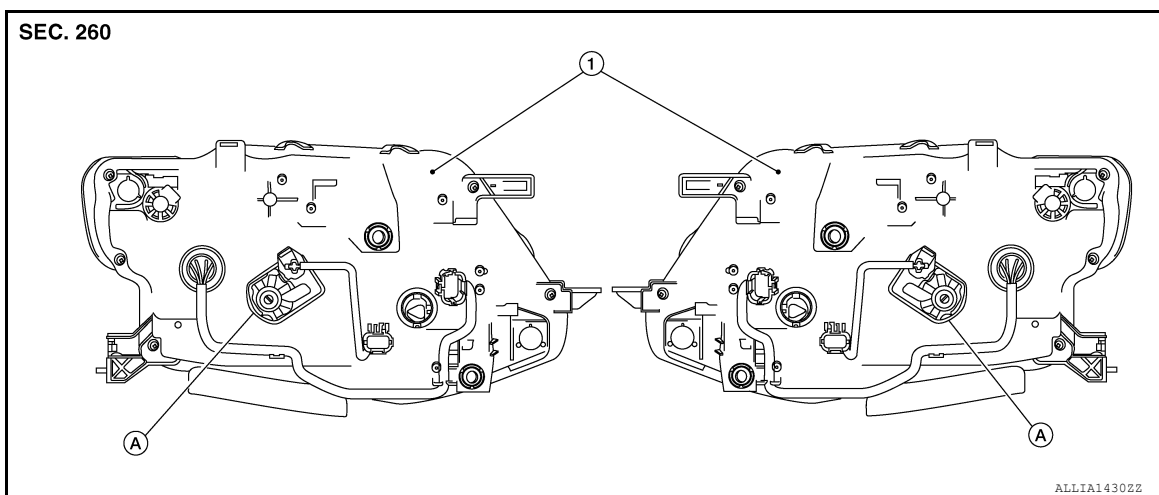

1. Front combination lamp
(view from rear)

A. Headlamp HI/LO (UP/DOWN)
adjustment screw

HEADLAMP AIMING ADJUSTMENT

< PERIODIC MAINTENANCE >

[LED HEADLAMP]

Aiming Adjustment Procedure

INFOID:000000011280906

Aiming Chart

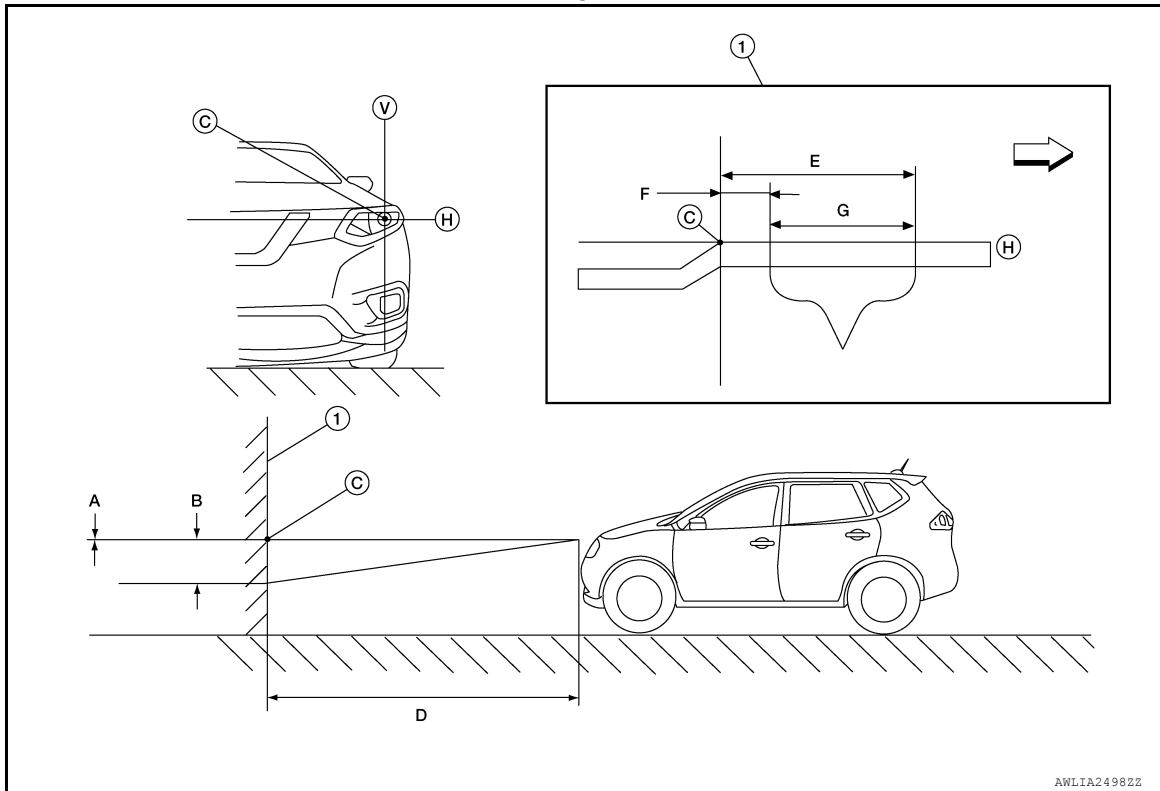

- | | | |
|---|---|---|
| 1. Adjustment screen | A. Highest cutoff line height | B. Lowest cutoff line height |
| C. Headlamp bulb center (H-V point) | D. Distance of headlamp aiming screen from vehicle 7.62 m (25 ft) | E. Maximum aim evaluation distance from vertical center on aiming screen 399 mm (3°R) |
| F. Minimum aim evaluation distance from vertical center on aiming screen 133 mm (1°R) | G. Aim evaluation area | H. Horizontal aiming evaluation line |
| V. Vertical aiming evaluation line | ↔ Right | |

A (Highest cutoff line height)	-13.3 mm (0.5 in)	0.1° up
B (Lowest cutoff line height)	53.2 mm (2.1 in)	0.4° down

LOW BEAM AND HIGH BEAM

NOTE:

- Basic illuminating area for evaluation and/or adjustment should be within range shown on aiming chart.

- Use adjustment screw to perform aiming adjustment.
 - Ensure fog lamps are turned off.
- Block the opposite headlamp from projecting a beam pattern onto the adjustment screen, using a suitable object. Aim each headlamp individually.

CAUTION:

Do not cover the lens surface with a tape etc. The lens is made of resin.

- Place the screen on the same level and flat surface as the vehicle.

NOTE:

Surface should be free of any debris that would cause a difference between the headlamp center and the adjustment screen.

- Face the front of the vehicle to the screen and measure distance between the headlamp center and the screen surface.

HEADLAMP AIMING ADJUSTMENT

< PERIODIC MAINTENANCE >

[LED HEADLAMP]

Distance between the headlamp center and the screen (D) : 7.62 m (25 ft)

5. Start the engine. Turn the headlamp on.
6. Determine the preferred vertical aim range dimensions, using the aiming chart.
7. Measure the projected beam within the aim evaluation segment on the screen.
8. Adjust the beam pattern of each headlamp until the aim evaluation segment (the area relative to both the highest and lowest cutoff line height) is positioned within the vertical aim range dimensions shown on the aiming chart.

A
B
C
D
E
F
G
H
I
J
K
EXL
M
N
O
P

FRONT FOG LAMP AIMING ADJUSTMENT

< PERIODIC MAINTENANCE >

[LED HEADLAMP]

FRONT FOG LAMP AIMING ADJUSTMENT

Aiming Adjustment Procedure

INFOID:000000011280907

Aiming Chart

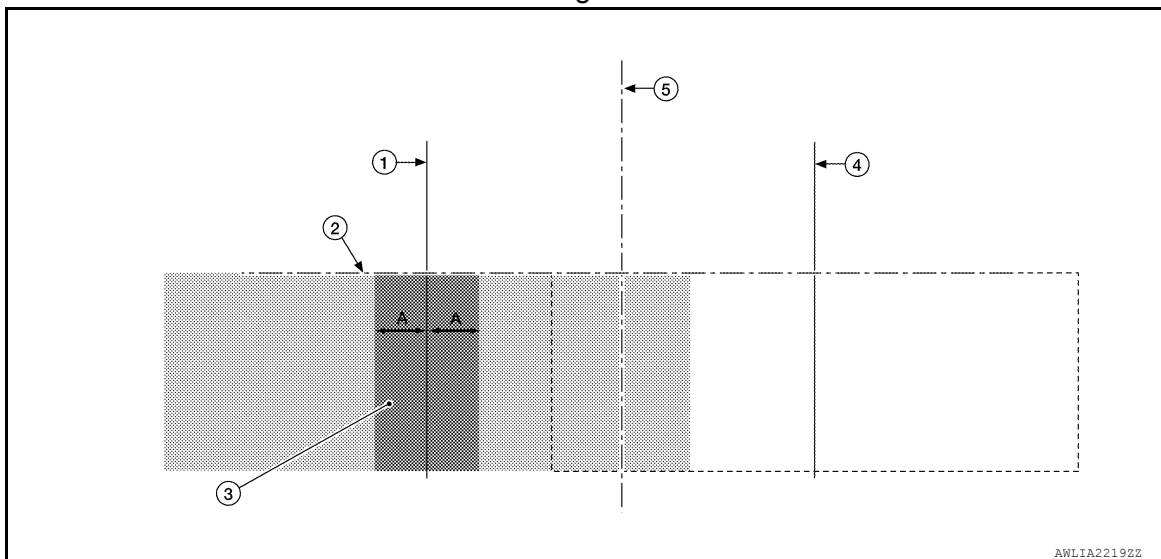

- | | | |
|--|-----------------------------|--|
| 1. Vertical center line of front fog lamp (LH) | 2. Lamp center above ground | 3. Front fog lamp high intensity area (LH) |
| 4. Vertical center line of front fog lamp (RH) | 5. Vertical center axis | A. 100mm (4in) |

NOTE:

- (LH) Front fog lamp aiming specifications shown, (RH) similar.
- Check the following conditions before performing the aiming adjustment.
 - Keep all tires inflated to correct pressure.
 - Place vehicle on level ground.
 - See that vehicle is unloaded (except for full levels of coolant, engine oil and fuel, and spare tire, jack, and tools). Have the driver or equivalent weight placed in driver seat.
 - When performing adjustment, if necessary, cover the headlamps and opposite front fog lamp.

1. Set the distance between the screen and the center of the front fog lamp lens as shown.

- (1) Aiming screen or a matte white surface
- (2) 7.62 m (25 ft)
- (3) Floor to center of front fog lamp lens
- (4) Floor

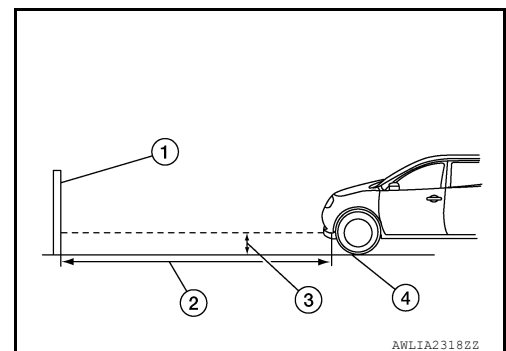

2. Turn front fog lamps ON.

FRONT FOG LAMP AIMING ADJUSTMENT

< PERIODIC MAINTENANCE >

[LED HEADLAMP]

3. Access adjusting screw (A) from underneath front bumper fascia. Adjust front fog lamps using adjusting screw so that the top edge of the high intensity zone is at the front fog lamp centers above ground.

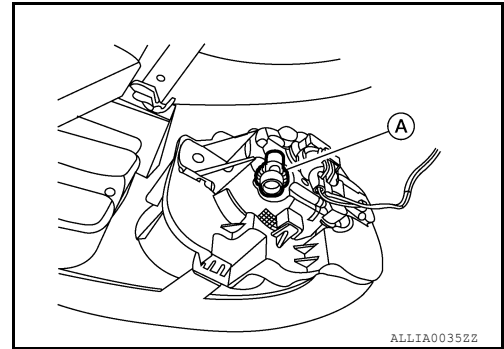

A
B
C
D
E
F
G
H
I
J
K
EXL
M
N
O
P

FRONT COMBINATION LAMP

< REMOVAL AND INSTALLATION >

[LED HEADLAMP]

REMOVAL AND INSTALLATION

FRONT COMBINATION LAMP

Exploded View

INFOID:000000011280908

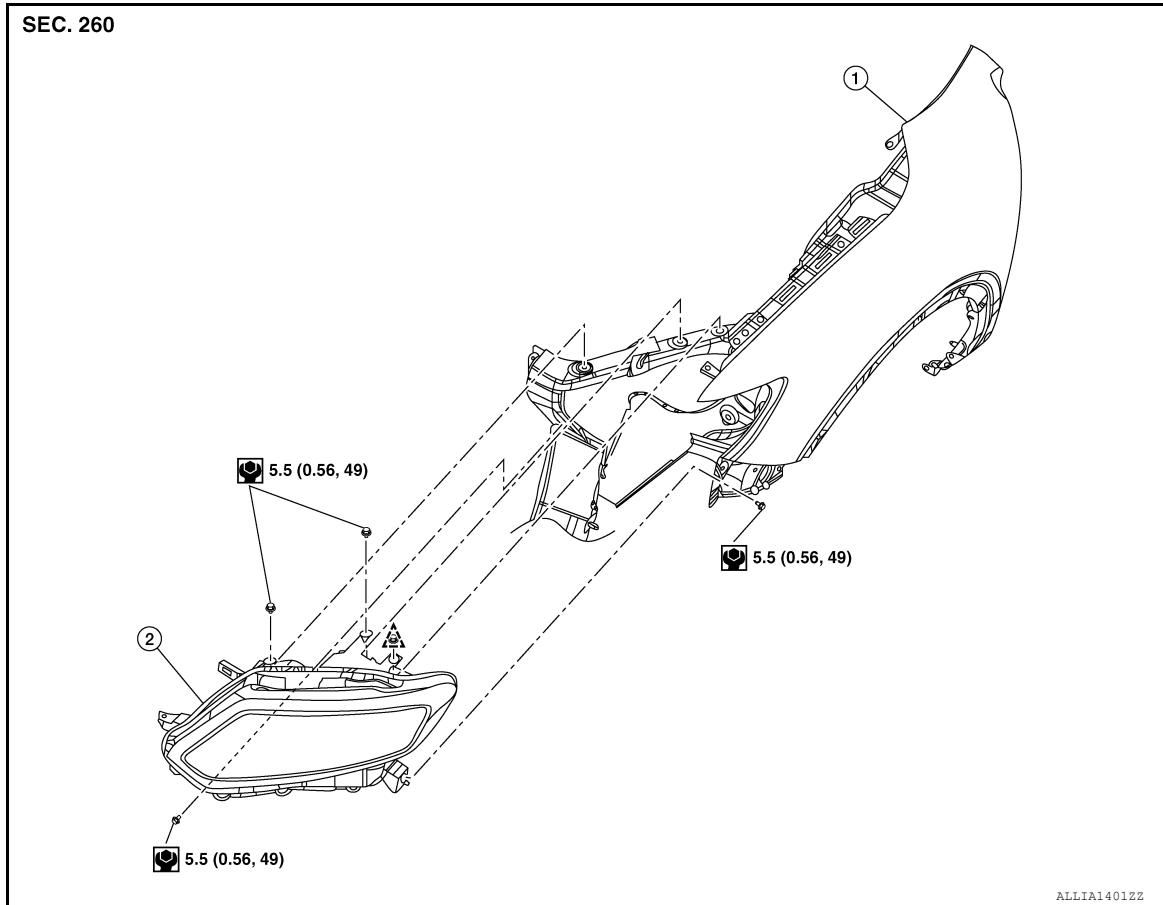

1. Front fender

2. Front combination lamp

Clip

Removal and Installation

INFOID:000000011280909

REMOVAL

1. Remove front bumper fascia. Refer to [EXT-17, "Removal and Installation"](#).
2. Remove front combination lamp bolts and clip.
3. Pull front combination lamp forward.
4. Disconnect the harness connectors from the front combination lamp and remove.

INSTALLATION

Installation is in the reverse order of removal.

NOTE:

After installation, perform headlamp aiming adjustment. Refer to [EXL-114, "Inspection"](#).

Bulb Replacement

INFOID:000000011280910

HEADLAMP (LOW BEAM) BULB

The headlamp (low beam) bulb is not serviced separately. Refer to [EXL-266, "Removal and Installation"](#).

HEADLAMP (HIGH BEAM) BULB

The headlamp (high beam) bulb is not serviced separately. Refer to [EXL-266, "Removal and Installation"](#).

FRONT COMBINATION LAMP

< REMOVAL AND INSTALLATION >

[LED HEADLAMP]

SIDE MARKER LAMP BULB

The side marker lamp bulb is not serviced separately. Refer to [EXL-266. "Removal and Installation"](#).

TURN SIGNAL LAMP BULB

Removal

1. Rotate bulb socket counterclockwise and remove from the front combination lamp.
2. Remove the bulb from bulb socket.

Installation

Installation is in the reverse order of removal.

CAUTION:

After installing the bulb, install the bulb socket securely for watertightness.

A
B
C
D
E
F
G
H
I
J
K
EXL
M
N
O
P

HEIGHT SENSOR

< REMOVAL AND INSTALLATION >

[LED HEADLAMP]

HEIGHT SENSOR

Exploded View

INFOID:000000011280911

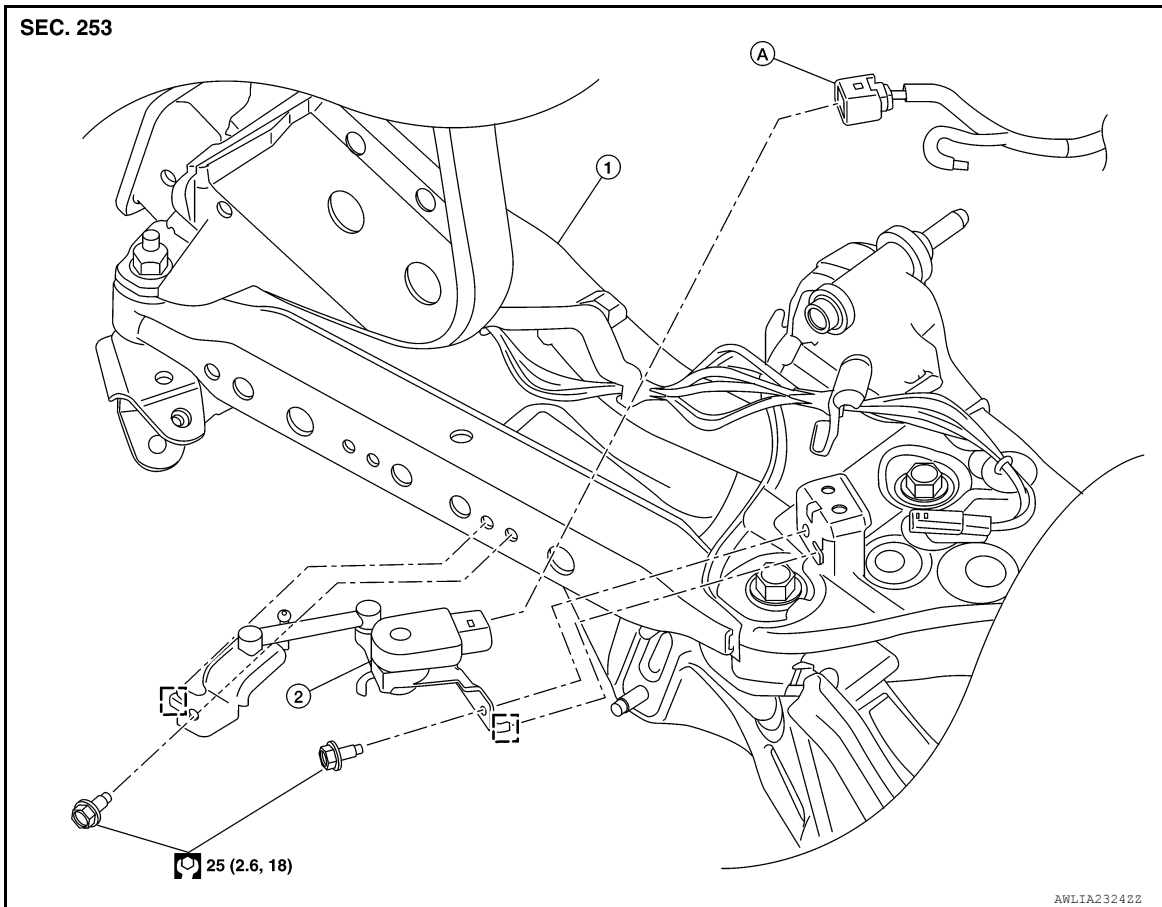

1. Rear suspension member 2. Rear height sensor A. Harness connector
[] Locator

Removal and Installation - Rear Height Sensor

INFOID:000000011280912

REMOVAL

1. Disconnect the harness connector from the rear height sensor.
2. Remove the bolts and rear height sensor.

INSTALLATION

Installation is in the reverse order of removal.

CAUTION:

Perform the sensor initialize of the headlamp aiming control system. Refer to [EXL-221, "SENSOR INITIALIZE : Description"](#).

FRONT FOG LAMP

< REMOVAL AND INSTALLATION >

[LED HEADLAMP]

FRONT FOG LAMP

Exploded View

INFOID:000000011280913

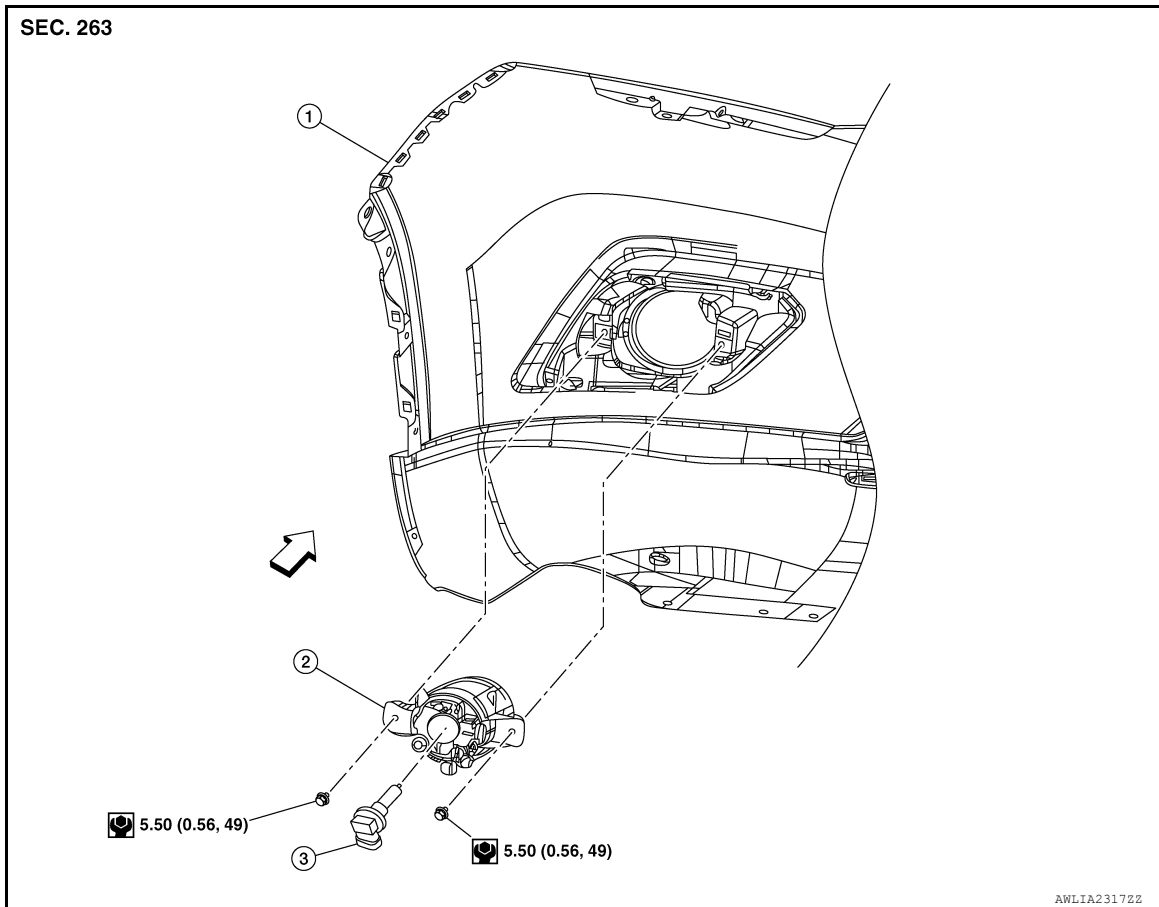

1. Front bumper fascia
2. Front fog lamp
3. Front fog lamp bulb
- ← Front

Removal and Installation

INFOID:000000011280914

EXL

REMOVAL

1. Partially remove front fender protector.
2. Disconnect the harness connector from the front fog lamp.
3. Remove front fog lamp bolts and front fog lamp.

INSTALLATION

Installation in the reverse order of removal.

NOTE:

After installation, perform front fog lamp aiming adjustment. Refer to [EXL-117. "Aiming Adjustment Procedure"](#).

Bulb Replacement

INFOID:000000011280915

WARNING:

Do not touch bulb by hand while it is lit or right after being turned off. Burning may result.

CAUTION:

- Do not touch the glass surface of the bulb with bare hands or allow oil or grease to get on it to prevent damage to the bulb.

FRONT FOG LAMP

< REMOVAL AND INSTALLATION >

[LED HEADLAMP]

- Do not leave bulb out of lamp reflector for a long time because dust, moisture smoke, etc. may affect the performance of lamp. When replacing bulb, be sure to replace it with new one.

REMOVAL

1. Partially remove front fender protector. Refer to [EXT-28. "FENDER PROTECTOR : Exploded View"](#).
2. Disconnect the harness connector from the front fog lamp (A).
3. Rotate bulb (1) counterclockwise and remove.

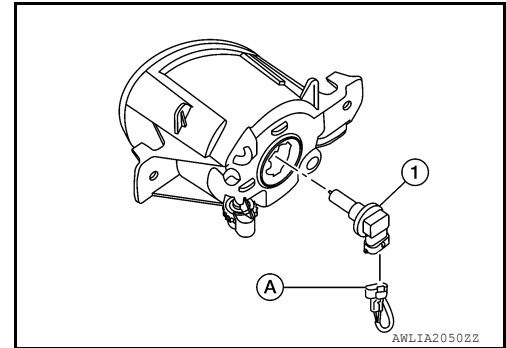

INSTALLATION

Installation is in the reverse order of removal.

CAUTION:

After installing the bulb, install the bulb socket securely for watertightness.

OPTICAL SENSOR

< REMOVAL AND INSTALLATION >

[LED HEADLAMP]

OPTICAL SENSOR

Exploded View

INFOID:000000011372324

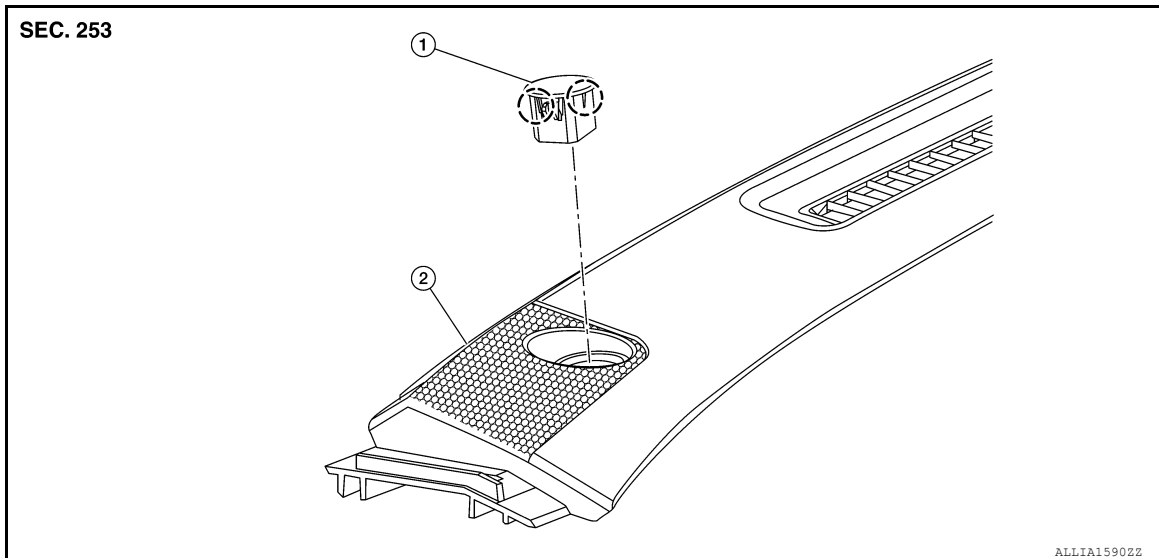

1. Optical sensor

2. Defroster grille

○ Pawl

Removal and Installation

INFOID:000000011280916

REMOVAL

1. Release the optical sensor (2) from defroster grille (1) using a suitable tool.
2. Disconnect the harness connector (A) from the optical sensor (2) and remove.

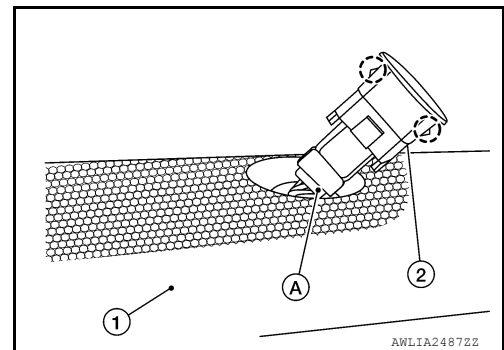

INSTALLATION

Installation is in the reverse order of removal.

A
B
C
D
E
F
G
H
I
J
K
EXL
M
N
O
P

COMBINATION SWITCH

< REMOVAL AND INSTALLATION >

[LED HEADLAMP]

COMBINATION SWITCH

Exploded View

INFOID:000000011280917

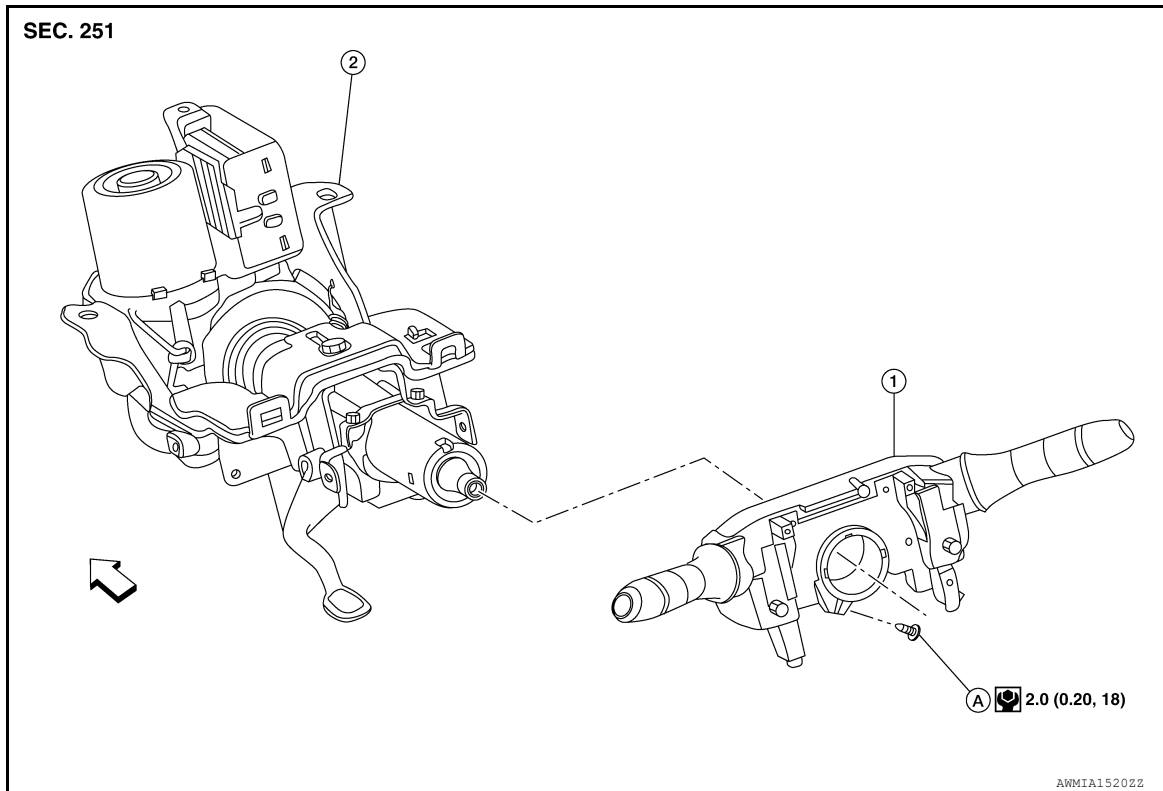

1. Combination switch

2. Steering column

A. Screw

⇐ Front

Removal and Installation

INFOID:000000011280918

REMOVAL

1. Remove the steering angle sensor. Refer to [BRC-137, "Removal and Installation"](#).
2. Disconnect harness connector from combination switch.
3. Remove screw (A) and combination switch (1).

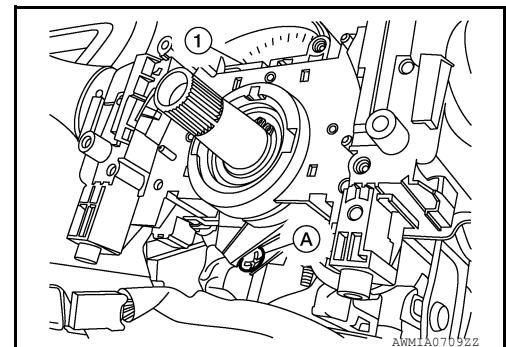

INSTALLATION

Installation is in the reverse order of removal.

HAZARD SWITCH

< REMOVAL AND INSTALLATION >

[LED HEADLAMP]

HAZARD SWITCH

Exploded View

INFOID:000000011280919

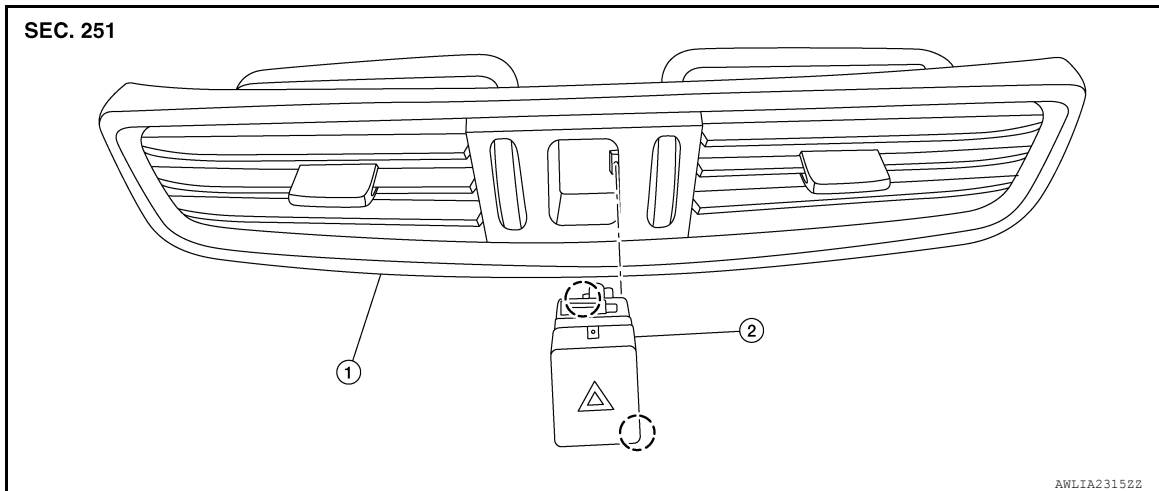

1. Center ventilator grille

2. Hazard switch

3. Pawl

Removal and Installation

INFOID:000000011280920

REMOVAL

1. Remove center ventilator grille. Refer to [VTL-13. "CENTER VENTILATOR GRILLE : Removal and Installation"](#).
2. Release the pawls and remove the hazard switch.

INSTALLATION

Installation is in the reverse order of removal.

A
B
C
D
E
F
G
H
I
J
K
EXL
M
N
O
P

SIDE TURN SIGNAL LAMP

[LED HEADLAMP]

< REMOVAL AND INSTALLATION >

SIDE TURN SIGNAL LAMP

Removal and Installation

INFOID:000000011280921

REMOVAL

1. Remove door mirror rear finisher. Refer to [MIR-26, "Removal and Installation"](#).
2. Remove door mirror glass. Refer to [MIR-24, "Removal and Installation"](#).
3. Remove the screws (A) and reposition side turn signal lamp.

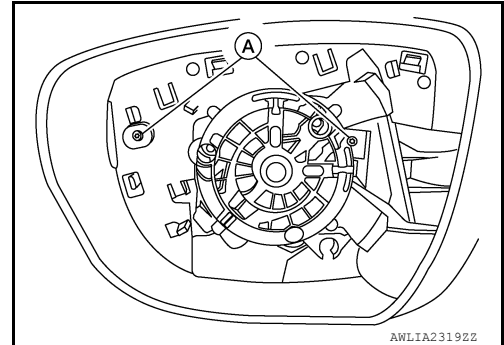

4. Disconnect the harness connector from the side turn signal lamp and remove.

INSTALLATION

Installation is in the reverse order of removal.

Bulb Replacement

INFOID:000000011280922

The side turn signal lamp bulb is not serviced separately. Refer to [EXL-126, "Removal and Installation"](#).

REAR COMBINATION LAMP

< REMOVAL AND INSTALLATION >

[LED HEADLAMP]

REAR COMBINATION LAMP

Exploded View

INFOID:000000011280923

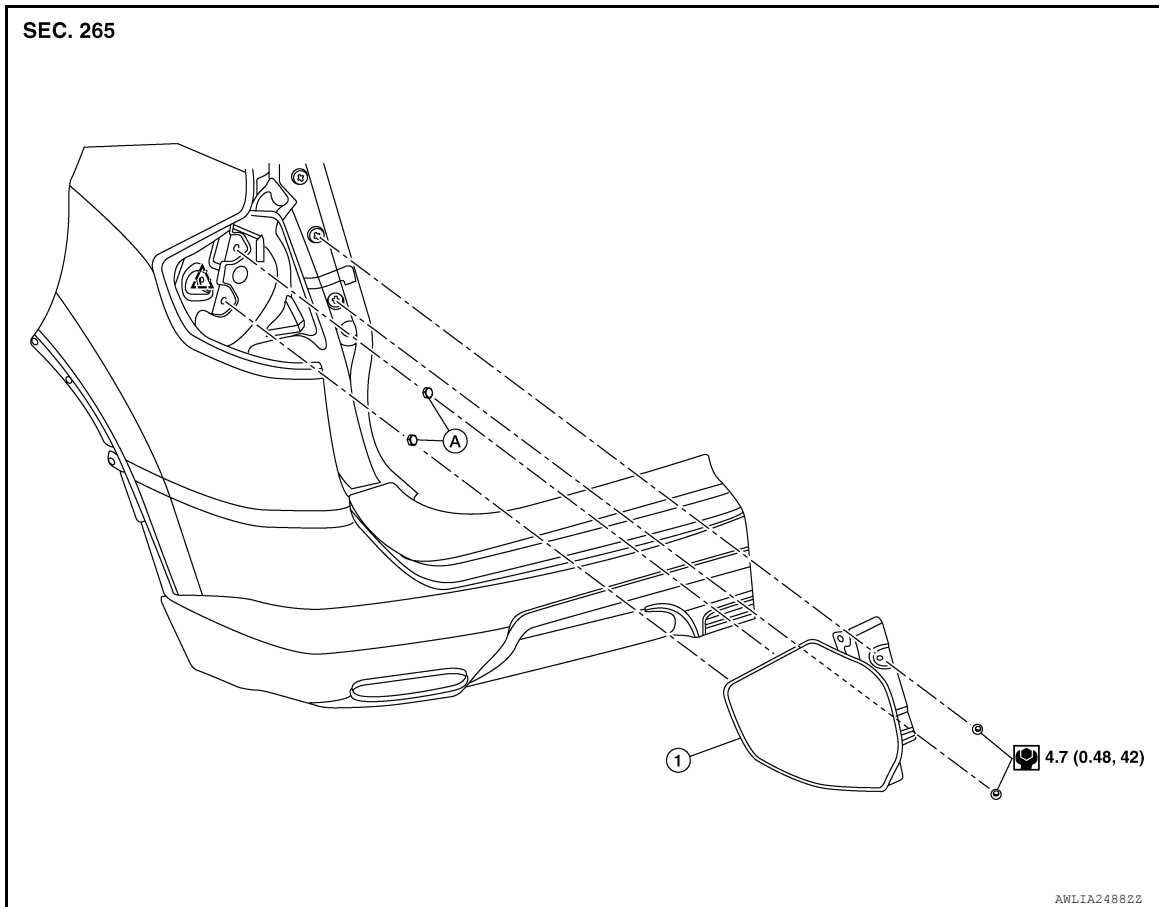

1. Rear combination lamp

A. Grommet

B. Clip

Removal and Installation

INFOID:000000011280924

REMOVAL

1. Remove side air spoiler. Refer to [EXT-49. "Removal and Installation"](#).
2. Remove rear combination lamp bolts.
3. Pull rear combination lamp rearward to release from clip and locators.
4. Disconnect the harness connector from the rear combination lamp and remove.

INSTALLATION

Installation is in the reverse order of removal.

Bulb Replacement

INFOID:000000011280925

WARNING:

Do not touch bulb with bare hand while it is lit or right after being turned off. Burning may result.

CAUTION:

- Do not touch the glass surface of the bulb with bare hands or allow oil or grease to get on it to prevent damage to the bulb.
- Do not leave bulb out of lamp reflector for a long time because dust, moisture smoke, etc. may affect the performance of lamp. When replacing bulb, be sure to replace it with new one.

STOP LAMP BULB

A
B
C
D
E
F
G
H
I
J
K

EXL

M

N

O

P

REAR COMBINATION LAMP

[LED HEADLAMP]

< REMOVAL AND INSTALLATION >

Removal

1. Remove rear combination lamp. Refer to [EXL-127. "Removal and Installation"](#).
2. Rotate stop lamp bulb socket counterclockwise and remove.
3. Remove stop lamp bulb from bulb socket.

Installation

Installation is in the reverse order of removal.

CAUTION:

After installing the bulb, install bulb socket securely for watertightness.

TAIL LAMP BULB

Removal

1. Remove rear combination lamp. Refer to [EXL-127. "Removal and Installation"](#).
2. Rotate tail lamp bulb socket counterclockwise and remove.
3. Remove tail lamp bulb from bulb socket.

Installation

Installation is in the reverse order of removal.

CAUTION:

After installing the bulb, install bulb socket securely for watertightness.

TURN SIGNAL LAMP BULB

Removal

1. Remove rear combination lamp. Refer to [EXL-127. "Removal and Installation"](#).
2. Rotate turn signal lamp bulb socket counterclockwise and remove.
3. Remove turn signal lamp bulb from bulb socket.

Installation

Installation is in the reverse order of removal.

CAUTION:

After installing the bulb, install bulb socket securely for watertightness.

HIGH-MOUNTED STOP LAMP

< REMOVAL AND INSTALLATION >

[LED HEADLAMP]

HIGH-MOUNTED STOP LAMP

Exploded View

INFOID:000000011280926

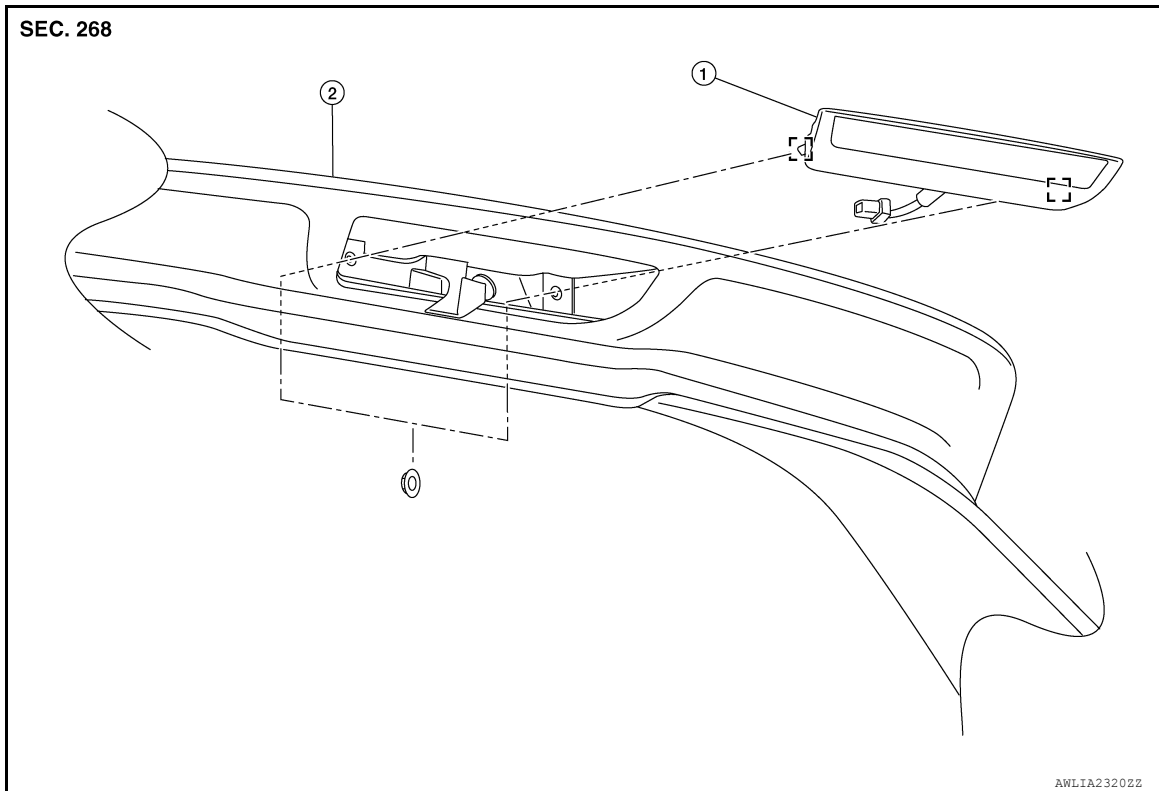

1. High-mounted stop lamp

2. Back door

Stud

Removal and Installation

INFOID:000000011280927

REMOVAL

1. Remove access cover using a suitable tool. Refer to [INT-38, "Exploded View"](#).
2. Remove high-mounted stop lamp nuts.
3. Disconnect the harness connector from high-mounted stop lamp and remove.

INSTALLATION

Installation is in the reverse order of removal.

Bulb Replacement

INFOID:000000011280928

HIGH-MOUNTED STOP LAMP BULB

The high-mounted stop lamp bulb is not serviced separately. Refer to [EXL-129, "Removal and Installation"](#).

BACK-UP LAMP ASSEMBLY

< REMOVAL AND INSTALLATION >

[LED HEADLAMP]

BACK-UP LAMP ASSEMBLY

Exploded View

INFOID:000000011280929

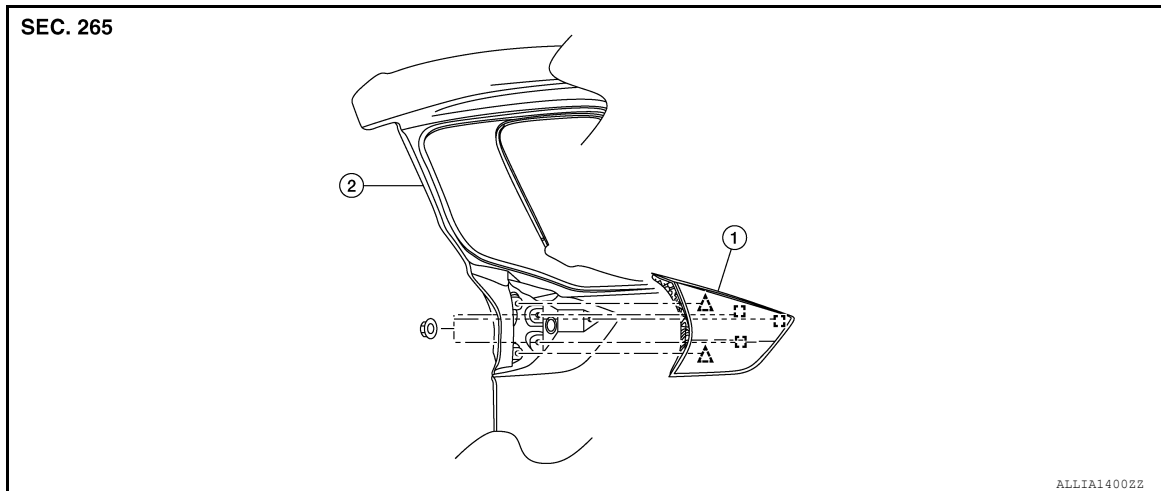

1. Back-up lamp assembly

2. Back door

 Clip

 Stud

Removal and Installation

INFOID:000000011280930

REMOVAL

1. Remove back door finisher. Refer to [INT-38. "Removal and Installation"](#).
2. Remove back-up lamp assembly nuts.
3. Pull back-up lamp assembly rearward, disconnect the harness connector and remove.

INSTALLATION

Installation is in the reverse order of removal.

Bulb Replacement

INFOID:000000011280931

WARNING:

Do not touch bulb with bare hand while it is lit or right after being turned off. Burning may result.

CAUTION:

- Do not touch the glass surface of the bulb with bare hands or allow oil or grease to get on it to prevent damage to the bulb.
- Do not leave bulb out of lamp reflector for a long time because dust, moisture smoke, etc. may affect the performance of lamp. When replacing bulb, be sure to replace it with new one.

TAIL LAMP BULB

Removal

1. Remove back-up lamp assembly. Refer to [EXL-130. "Removal and Installation"](#).
2. Rotate tail lamp bulb socket counterclockwise and remove.
3. Remove tail lamp bulb from bulb socket.

Installation

Installation is in the reverse order of removal.

CAUTION:

After installing the bulb, install bulb socket securely for watertightness.

BACK-UP LAMP BULB

Removal

BACK-UP LAMP ASSEMBLY

[LED HEADLAMP]

< REMOVAL AND INSTALLATION >

1. Remove back-up lamp assembly. Refer to [EXL-130. "Removal and Installation"](#).
2. Rotate back-up lamp bulb socket counterclockwise and remove.
3. Remove back-up lamp bulb from bulb socket.

Installation

Installation is in the reverse order of removal.

CAUTION:

After installing the bulb, install bulb socket securely for watertightness.

A
B
C
D
E
F
G
H
I
J
K
EXL
M
N
O
P

LICENSE PLATE LAMP

< REMOVAL AND INSTALLATION >

[LED HEADLAMP]

LICENSE PLATE LAMP

Exploded View

INFOID:000000011280932

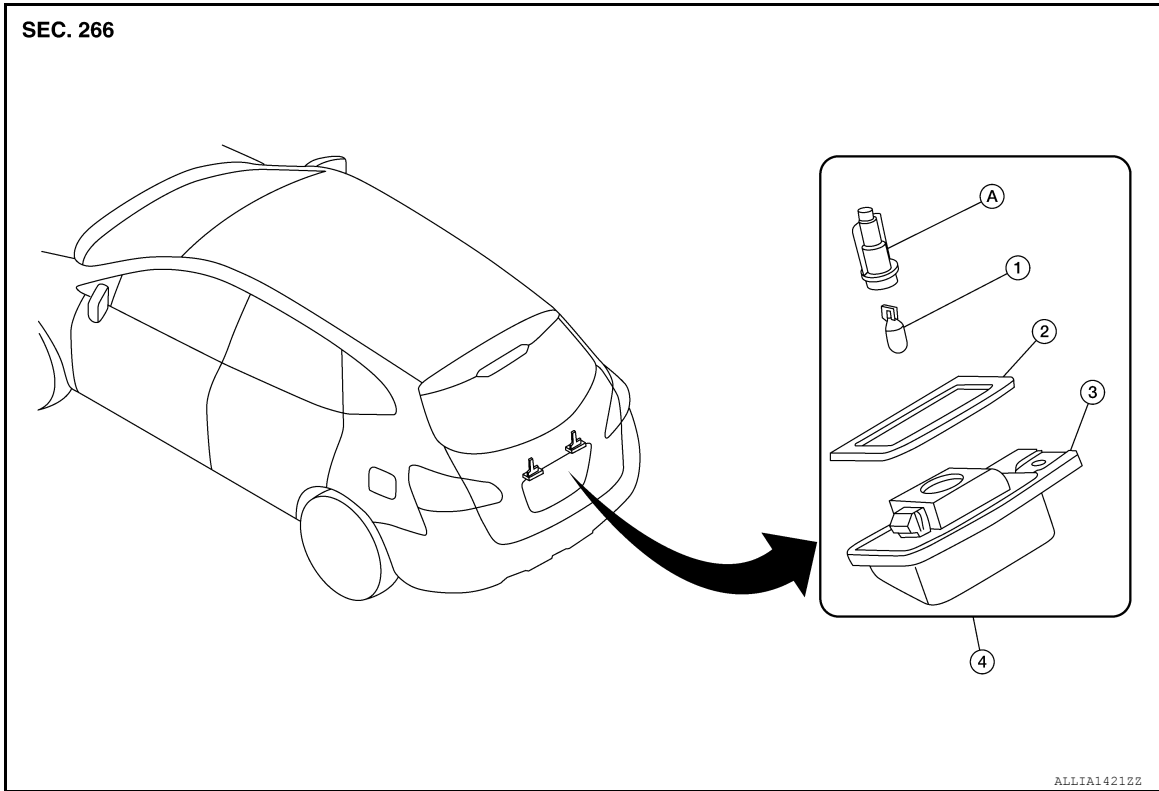

- | | | |
|--------------------------------|-----------------------------------|-----------------------|
| 1. License plate lamp bulb | 2. License plate lamp seal | 3. License plate lamp |
| 4. License plate lamp assembly | A. License plate lamp bulb socket | |

Removal and Installation

INFOID:000000011280933

REMOVAL

1. Release the license lamp finisher. Refer to [EXT-51. "Exploded View"](#).
2. Remove the screw (A) (LH or RH) and pull license plate lamp (1) (LH or RH) rearward.

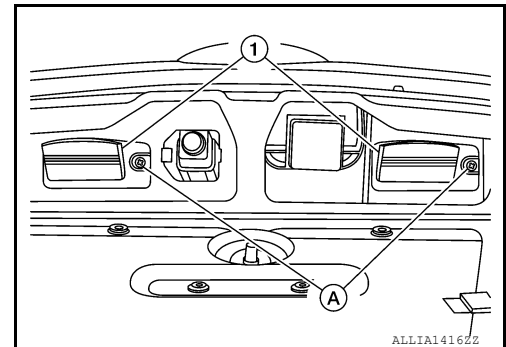

3. Disconnect the harness connector from the license plate lamp and remove.

INSTALLATION

Installation is in the reverse order of removal.

Bulb Replacement

INFOID:000000011280934

WARNING:

Do not touch bulb with your hand while it is on or right after being turned off. Burning may result.

LICENSE PLATE LAMP

< REMOVAL AND INSTALLATION >

[LED HEADLAMP]

CAUTION:

- Do not touch the glass surface of the bulb with bare hands or allow oil or grease to get on it to prevent damage to the bulb.
- Do not leave bulb out of lamp reflector for a long time because dust, moisture smoke, etc. may affect the performance of lamp. When replacing bulb, be sure to replace it with new one.

REMOVAL

1. Remove license plate lamp. Refer to [EXL-280. "Removal and Installation"](#).
2. Rotate license plate lamp bulb socket counterclockwise and remove.
3. Remove license plate lamp bulb from bulb socket.

INSTALLATION

Installation is in the reverse order of removal.

CAUTION:

After installing the bulb, install the bulb socket securely for watertightness.

A
B
C
D
E
F
G
H
I
J
K
L
M
N
O
P

EXL

FRONT COMBINATION LAMP

< UNIT DISASSEMBLY AND ASSEMBLY >

[LED HEADLAMP]

UNIT DISASSEMBLY AND ASSEMBLY

FRONT COMBINATION LAMP

Exploded View

INFOID:000000011280935

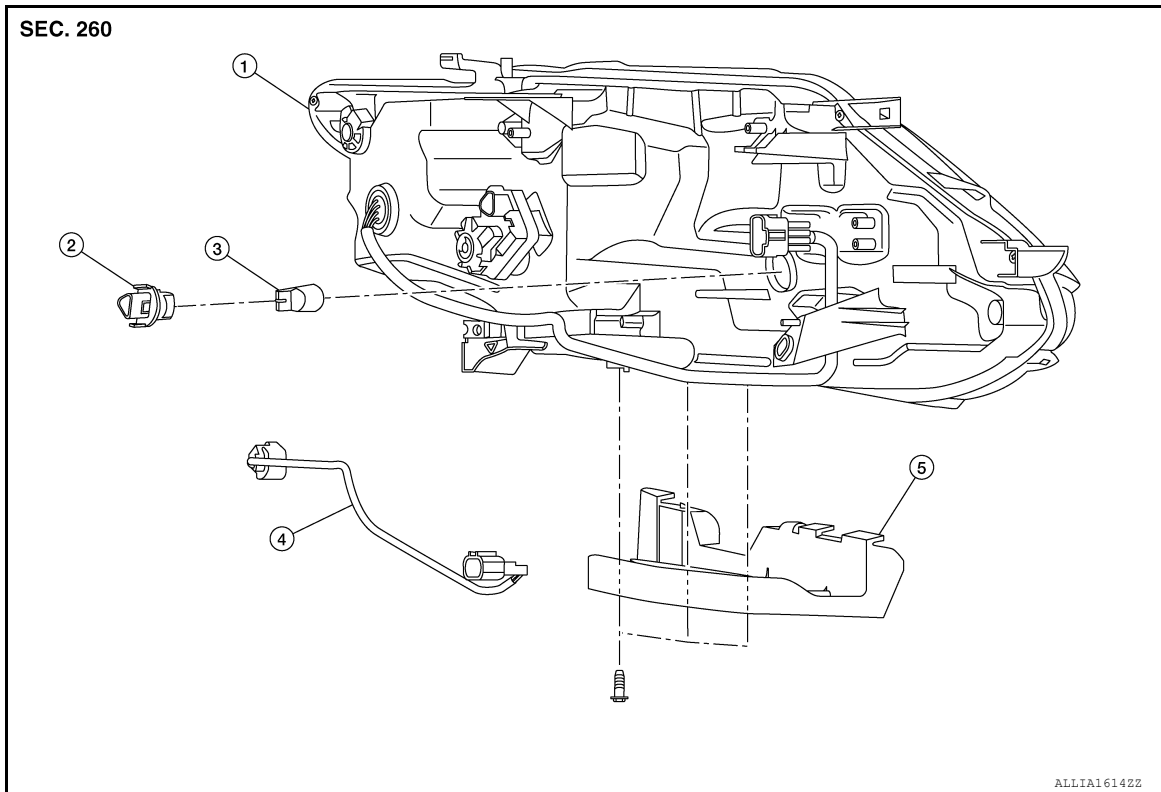

1. Front combination lamp
2. Turn signal lamp bulb socket
3. Turn signal lamp bulb
4. Front combination lamp harness
5. Front combination lamp mounting bracket

Disassembly and Assembly

INFOID:000000011280936

DISASSEMBLY

1. Remove front combination lamp. Refer to [EXL-266, "Removal and Installation"](#).
2. Rotate the turn signal lamp bulb socket counterclockwise and remove.
3. Remove the turn signal lamp bulb from the bulb socket.

ASSEMBLY

Assembly is in the reverse order of disassembly.

REAR COMBINATION LAMP

< UNIT DISASSEMBLY AND ASSEMBLY >

[LED HEADLAMP]

REAR COMBINATION LAMP

Exploded View

INFOID:000000011280937

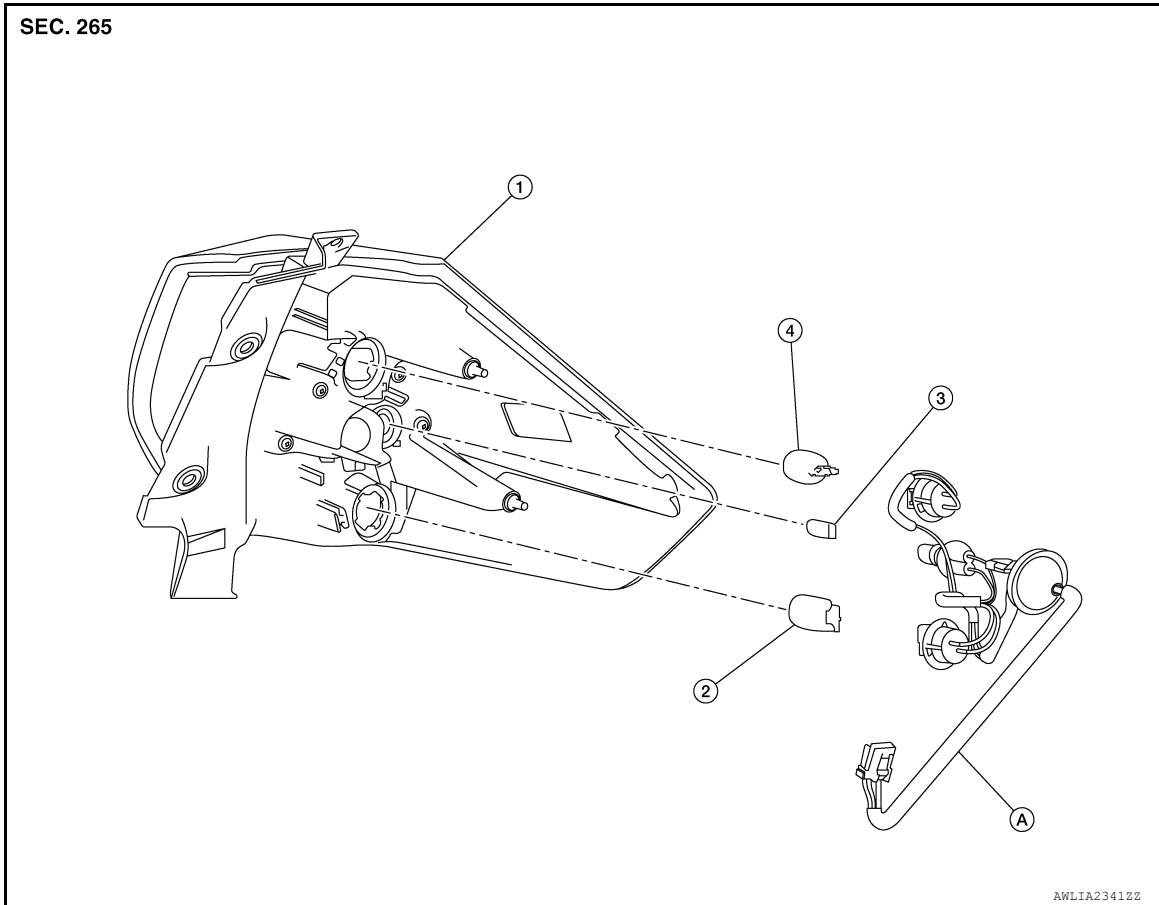

- | | | |
|--------------------------|----------------------------------|-------------------|
| 1. Rear combination lamp | 2. Turn signal lamp bulb | 3. Tail lamp bulb |
| 4. Stop lamp bulb | A. Rear combination lamp harness | |

Disassembly and Assembly

INFOID:000000011280938

DISASSEMBLY

1. Remove rear combination lamp. Refer to [EXL-275. "Removal and Installation"](#).
2. Rotate the stop lamp bulb socket counterclockwise and remove.
3. Remove the stop lamp bulb from the bulb socket.
4. Rotate the tail lamp bulb socket counterclockwise and remove.
5. Remove the tail lamp bulb from the bulb socket.
6. Rotate the turn signal lamp bulb socket counterclockwise and remove.
7. Remove the turn signal lamp bulb from bulb socket.

ASSEMBLY

Assembly is in the reverse order of disassembly.

CAUTION:

After installing, be sure to install the bulb sockets securely to ensure watertightness.

SERVICE DATA AND SPECIFICATIONS (SDS)

< SERVICE DATA AND SPECIFICATIONS (SDS)

[LED HEADLAMP]

SERVICE DATA AND SPECIFICATIONS (SDS)

SERVICE DATA AND SPECIFICATIONS (SDS)

Bulb Specifications

INFOID:000000011280939

	Item	Wattage (W)*
Front combination lamp	High beam	—
	Low beam	—
	Turn signal lamp	28/8
	Side marker lamp	—
	Daytime running lamp	—
Front fog lamp		55
Side turn signal lamp		—
Rear combination lamp	Stop lamp	21
	Tail lamp	5
	Turn signal lamp	21
Back-up lamp	Tail lamp	5
	Back-up lamp	16
License plate lamp		5
High-mounted stop lamp		—

*: Always check with the Parts Department for the latest parts info.