

A
LU
C
D
E
F
G
H
I
J
K
L
M
N
O
P

SECTION LU

ENGINE LUBRICATION SYSTEM

CONTENTS

PRECAUTION	OIL FILTER
PRECAUTIONS	Removal and Installation
Precaution for Supplemental Restraint System (SRS) "AIR BAG" and "SEAT BELT PRE-TEN- SIONER"	Inspection
Liquid Gasket	REMOVAL AND INSTALLATION
PREPARATION	OIL COOLER
PREPARATION	Exploded View
Special Service Tools	Removal and Installation
Commercial Service Tools	Inspection
SYSTEM DESCRIPTION	OIL PUMP
DESCRIPTION	Exploded View
Engine Lubrication System	Removal and Installation
Engine Lubrication System Schematic	Disassembly and Assembly
PERIODIC MAINTENANCE	Inspection
ENGINE OIL	SERVICE DATA AND SPECIFICATIONS (SDS)
Inspection	SERVICE DATA AND SPECIFICATIONS (SDS)
Draining	Oil Pressure
Refilling	Oil Pump
	Relief Valve
	Oil Capacity

PRECAUTIONS

< PRECAUTION >

PRECAUTION

PRECAUTIONS

Precaution for Supplemental Restraint System (SRS) "AIR BAG" and "SEAT BELT PRE-TENSIONER"

INFOID:000000011277137

The Supplemental Restraint System such as "AIR BAG" and "SEAT BELT PRE-TENSIONER", used along with a front seat belt, helps to reduce the risk or severity of injury to the driver and front passenger for certain types of collision. Information necessary to service the system safely is included in the SR and SB section of this Service Manual.

WARNING:

- To avoid rendering the SRS inoperative, which could increase the risk of personal injury or death in the event of a collision which would result in air bag inflation, all maintenance must be performed by an authorized NISSAN/INFINITI dealer.
- Improper maintenance, including incorrect removal and installation of the SRS, can lead to personal injury caused by unintentional activation of the system. For removal of Spiral Cable and Air Bag Module, see the SR section.
- Do not use electrical test equipment on any circuit related to the SRS unless instructed to in this Service Manual. SRS wiring harnesses can be identified by yellow and/or orange harnesses or harness connectors.

PRECAUTIONS WHEN USING POWER TOOLS (AIR OR ELECTRIC) AND HAMMERS

WARNING:

- When working near the Airbag Diagnosis Sensor Unit or other Airbag System sensors with the Ignition ON or engine running, DO NOT use air or electric power tools or strike near the sensor(s) with a hammer. Heavy vibration could activate the sensor(s) and deploy the air bag(s), possibly causing serious injury.
- When using air or electric power tools or hammers, always switch the Ignition OFF, disconnect the battery and wait at least three minutes before performing any service.

Liquid Gasket

INFOID:000000011277138

REMOVAL OF LIQUID GASKET SEALING

- After removing the bolts and nuts, separate the mating surface and remove the liquid gasket using Tool (A).

Tool Number : KV10111100 (J-37228)

CAUTION:

Be careful not to damage the mating surfaces.

- In areas where the cutter is difficult to use, use a plastic hammer to lightly tap (1) the cutter where the liquid gasket is applied. Use a plastic hammer to slide (2) the cutter by tapping on the side.

CAUTION:

Do not damage the mating surfaces.

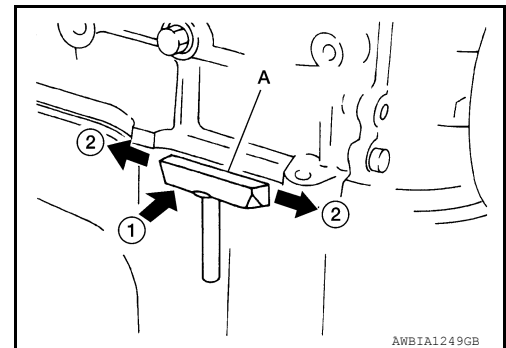

LIQUID GASKET APPLICATION PROCEDURE

1. Using suitable tool (A), remove old liquid gasket adhering to the liquid gasket application surface and the mating surface.
 - Remove liquid gasket completely from the groove of the liquid gasket application surface, mounting bolts, and bolt holes.
2. Thoroughly clean the mating surfaces and remove adhering moisture, grease and foreign material.

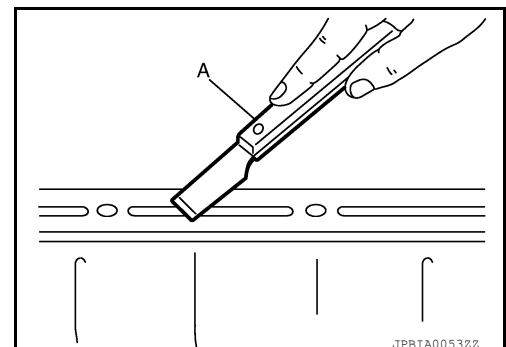

PRECAUTIONS

< PRECAUTION >

3. Attach liquid gasket tube to the suitable tool.
Use Genuine Silicone RTV Sealant, or equivalent. Refer to [GI-22, "Recommended Chemical Products and Sealants"](#).
4. Apply liquid gasket without gaps to the specified location according to the specified dimensions.
 - If there is a groove for liquid gasket application, apply liquid gasket to the groove.

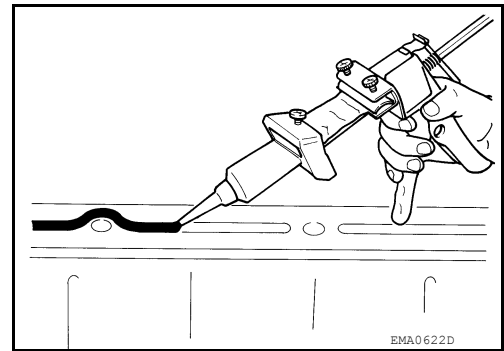

- As for bolt holes (B), normally apply liquid gasket inside the holes. Occasionally, it should be applied outside the holes. Check to read the text of this manual.

(A) : Groove

⇐ : Inside

- Within five minutes of liquid gasket application, install the mating component.
- If liquid gasket protrudes, wipe it off immediately.
- Do not retighten mounting bolts or nuts after the installation.
- After 30 minutes or more have passed from the installation, fill engine oil. Refer to [LU-8, "Refilling"](#).

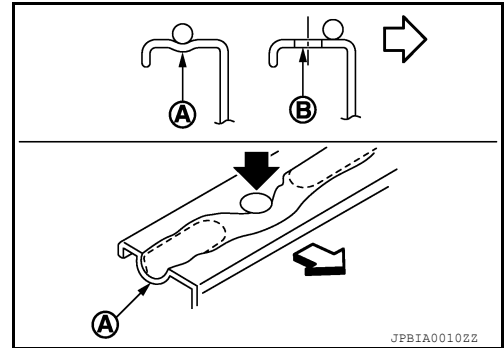

CAUTION:

If there are specific instructions in the procedures contained in this manual concerning liquid gasket application, observe them.

PREPARATION

< PREPARATION >

PREPARATION

PREPARATION

Special Service Tools

INFOID:0000000011277139

The actual shape of the tools may differ from those illustrated here.

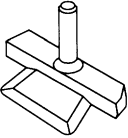
Tool number (TechMate No.) Tool name	Description
KV10111100 (J-37228) Seal cutter  <small>NT046</small>	Removing oil pan (lower) etc.

Commercial Service Tools

INFOID:0000000011277140

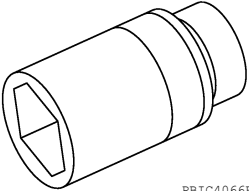
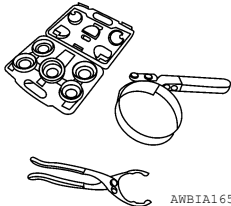
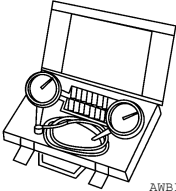
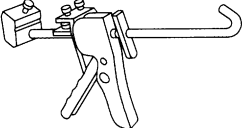
Tool name	Description
Deep socket  <small>PBIC4066E</small>	Removing and installing oil pressure sensor 27 mm (1.06 in)
Oil filter wrench assortment  <small>AWBIA16562Z</small>	Removing oil filter
Oil pressure kit  <small>AWBIA16572Z</small>	Measuring oil pressure. Comes with adapter and hose. Designed to be used for both static and on road testing.
Tube presser  <small>NT052</small>	Pressing the tube of liquid gasket

DESCRIPTION

< SYSTEM DESCRIPTION >

SYSTEM DESCRIPTION

DESCRIPTION

Engine Lubrication System

INFOID:000000011277141

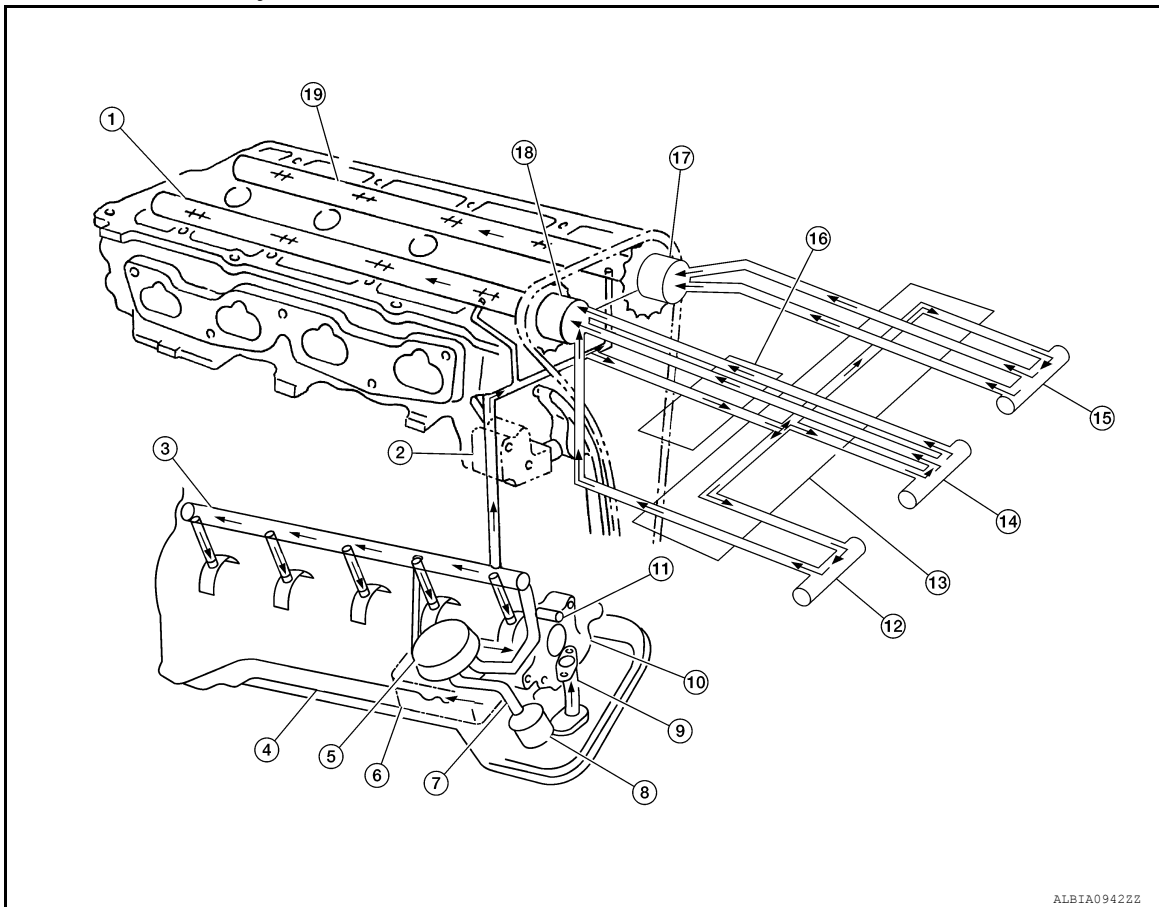

- | | | |
|---------------------------------------|---|--|
| 1. Camshaft (INT) | 2. Chain tensioner | 3. Main gallery |
| 4. Oil pan | 5. Oil cooler | 6. Balancer unit |
| 7. Oil pan oil gallery | 8. Oil filter (with relief valve) | 9. Oil Strainer |
| 10. Oil pump | 11. Timing chain and balancer unit timing chain oil jet | 12. Intake valve timing intermediate lock-control solenoid valve |
| 13. Intake valve timing control cover | 14. Intake valve timing control solenoid valve | 15. Exhaust valve timing control solenoid valve |
| 16. Front cover | 17. Exhaust valve timing controller | 18. Intake valve timing controller |
| 19. Camshaft (EXH) | | |

DESCRIPTION

< SYSTEM DESCRIPTION >

Engine Lubrication System Schematic

INFOID:000000011277142

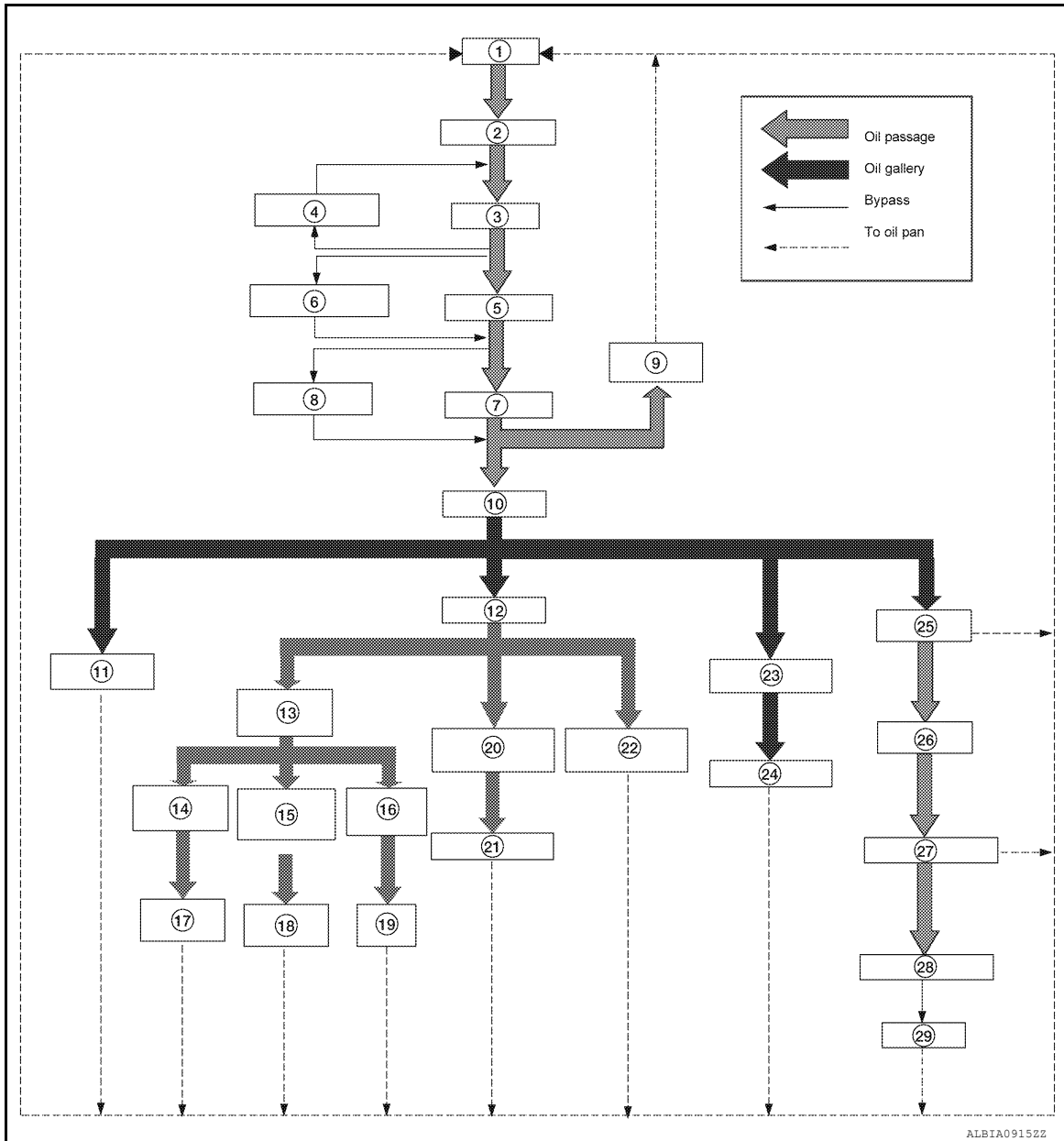

ALBIA09152Z

- | | | |
|------------------------------|------------------------------|---------------------------------------|
| 1. Oil pan | 2. Oil strainer | 3. Oil pump |
| 4. Regulator valve | 5. Oil filter | 6. Relief valve (Built in oil filter) |
| 7. Oil cooler | 8. Relief valve | 9. Chain oil jet |
| 10. Main gallery | 11. Piston oil jet | 12. Cylinder head |
| 13. C-VTC oil filter | 14. C-VTC EXH solenoid valve | 15. C-VTC intermediate solenoid valve |
| 16. C-VTC INT solenoid valve | 17. C-VTC exhaust | 18. C-VTC intermediate |
| 19. C-VTC intake | 20. Camshaft journal | 21. Camshaft |
| 22. Chain tensioner | 23. Balancer housing | 24. Balancershaft journal |
| 25. Main bearing | 26. Crankshaft | 27. Connecting rod bearing |
| 28. Connecting rod | 29. Piston | |

ENGINE OIL

< PERIODIC MAINTENANCE >

PERIODIC MAINTENANCE

ENGINE OIL

Inspection

INFOID:0000000011277143

A

LU

ENGINE OIL LEVEL

NOTE:

Before starting engine, put vehicle horizontally and check the engine oil level. If engine is already started, stop it and allow 5 minutes before checking.

1. Pull out oil level gauge and wipe it clean.
2. Insert oil level gauge and check the engine oil level is within the range (A) as shown.
3. If it is out of range, adjust it.

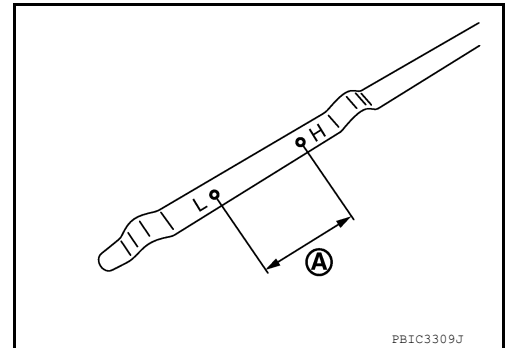

C

D

E

F

G

ENGINE OIL APPEARANCE

- Check engine oil for white milky appearance or excessive contamination.
- If engine oil becomes turbid and white, it is highly probable that it is contaminated with engine coolant. Repair or replace damaged parts.

H

ENGINE OIL LEAKS

Check for engine oil leaks around the following areas:

- Oil temperature sensor
- Oil level sensor
- Oil level gauge assembly O-ring.
- Crankshaft position sensor
- Camshaft position sensors
- Oil cooler
- Oil pan (upper and lower)
- Oil pan drain plug
- Oil pressure switch
- Oil filter
- Intake valve timing intermediate lock control solenoid valve
- Intake valve timing control solenoid valve
- Exhaust valve timing control solenoid valve
- Front cover
- Mating surface between cylinder head and camshaft bracket
- Mating surface between cylinder block and cylinder head
- Mating surface between cylinder head and rocker cover
- Crankshaft oil seals (front and rear)

I

J

K

L

M

OIL PRESSURE CHECK

WARNING:

- **Be careful not to get burn yourself, as engine oil may be hot.**
- **When checking engine oil pressure, CVT shift lever should be in "P" position. Be sure to apply parking brake.**

N

O

P

1. Check the engine oil level.
2. Remove fender protector side cover (RH). Refer to [EXT-28, "FENDER PROTECTOR : Exploded View"](#).
3. Disconnect harness connector at oil pressure switch and remove oil pressure switch using suitable tool.

CAUTION:

Never drop or shock oil pressure switch.

ENGINE OIL

< PERIODIC MAINTENANCE >

4. Install suitable tools (A/B).

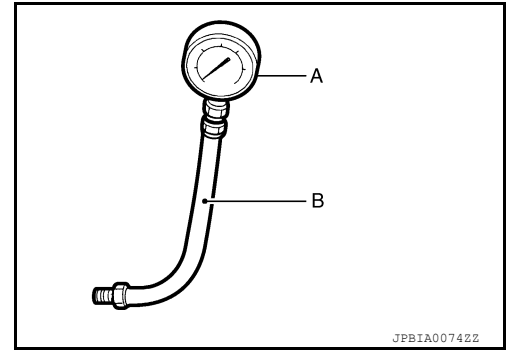

5. Start the engine and warm it up to normal operating temperature.
6. Check the engine oil pressure with engine running under no-load.

NOTE:

- When engine oil temperature is low, engine oil pressure becomes high.
- If difference is extreme, check oil passage and oil pump for engine oil leaks.

Engine oil pressure : Refer to [LU-18, "Oil Pressure"](#).

7. After the inspections, install oil pressure switch as follows:
 - a. Remove old liquid gasket adhering to oil pressure switch and engine.
 - b. Apply liquid gasket and tighten oil pressure switch to the specification.
Use Genuine RTV Silicone Sealant or equivalent. Refer to [GI-22, "Recommended Chemical Products and Sealants"](#).

Tightening torque : Refer to [EM-97, "Exploded View"](#).

8. Check engine oil level.
9. After warming up engine, check that there are no engine oil leaks with the engine running.
10. Install fender protector side cover (RH). Refer to [EXT-28, "FENDER PROTECTOR : Exploded View"](#).

Draining

INFOID:000000011277144

WARNING:

- Be careful not to get burn yourself, as engine oil may be hot.
- Prolonged and repeated contact with used engine oil may cause skin cancer. Try to avoid direct skin contact with used engine oil. If skin contact is made, wash thoroughly with soap or hand cleaner as soon as possible.

1. Warm up the engine, and check for engine oil leaks from engine components. Refer to [LU-7, "Inspection"](#).
2. Stop the engine and wait for 10 minutes.
3. Loosen oil filler cap.
4. Remove drain plug (1) and then drain engine oil.

⇐ : Front

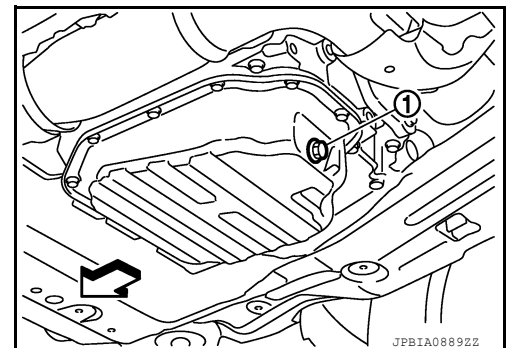

Refilling

INFOID:000000011277145

1. Install drain plug with new drain plug washer. Refer to [EM-36, "Exploded View"](#).

CAUTION:

ENGINE OIL

< PERIODIC MAINTENANCE >

Be sure to clean drain plug and install with new drain plug washer.

Tightening torque : Refer to [EM-36, "Exploded View"](#).

2. Refill with new engine oil.

Engine oil specification and viscosity: Refer to [MA-11, "Engine Oil Recommendation"](#).

Engine oil capacity : Refer to [LU-18, "Oil Capacity"](#).

CAUTION:

- The refill capacity depends on the engine oil temperature and drain time. Use these specifications for reference only.
- Always use oil level gauge to determine the proper amount of engine oil in engine.

3. Warm up the engine and check area around drain plug and oil filter for engine oil leaks.

4. Stop the engine and wait for 5 minutes.

5. Check the engine oil level. Refer to [LU-7, "Inspection"](#).

A

LU

C

D

E

F

G

H

I

J

K

L

M

N

O

P

OIL FILTER

< PERIODIC MAINTENANCE >

OIL FILTER

Removal and Installation

INFOID:000000011277146

REMOVAL

1. Remove fender protector side cover (RH). Refer to [EXT-28, "FENDER PROTECTOR : Exploded View"](#).
2. Drain engine oil. Refer to [LU-8, "Draining"](#).
3. Remove oil filter using suitable tool (A)..

↔ : Front

WARNING:

Be careful not to burn yourself, as engine oil may be hot.

CAUTION:

- When removing, prepare a shop cloth to absorb any engine oil leaks or spills.
- Do allow engine oil to adhere to drive belt.
- Completely wipe off any engine oil that adheres to engine and vehicle.

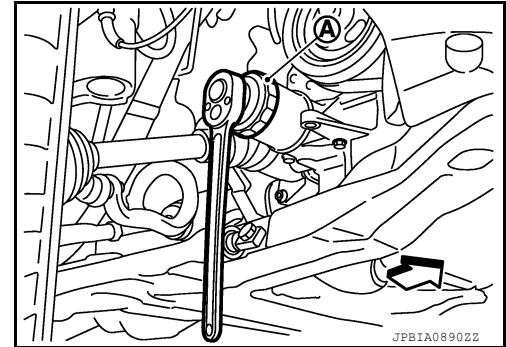

- Oil filter is provided with relief valve. Use genuine NISSAN oil filter or equivalent.

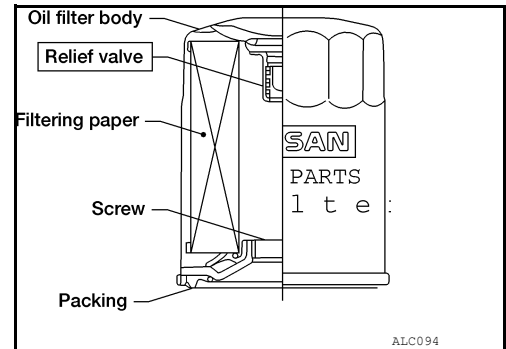

INSTALLATION

1. Remove foreign materials adhering to oil filter installation surface.
2. Apply new engine oil to the oil seal contact surface of new oil filter.

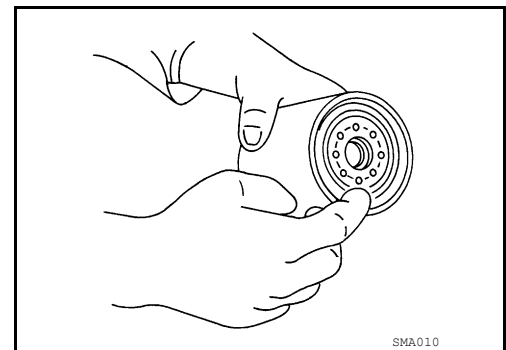

3. Screw oil filter manually until it touches the installation surface, then tighten it by 2/3 turn (A). Or tighten to the specification.

Oil filter:

 : 17.7 N·m (1.8 kg-m, 13 ft-lb)

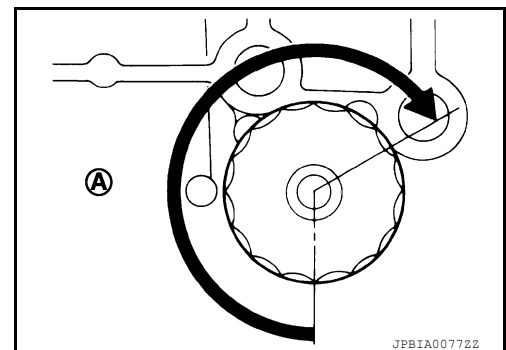

OIL FILTER

< PERIODIC MAINTENANCE >

Inspection

INFOID:000000011277147

A

INSPECTION AFTER INSTALLATION

1. Check the engine oil level. Refer to [LU-7, "Inspection"](#).
2. Start the engine, and check that there is are no leaks of engine oil.
3. Stop the engine and wait for at least 5 minutes.
4. Check the engine oil level, and adjust the level (if necessary). Refer to [LU-7, "Inspection"](#).

LU

C

D

E

F

G

H

I

J

K

L

M

N

O

P

OIL COOLER

< REMOVAL AND INSTALLATION >

REMOVAL AND INSTALLATION

OIL COOLER

Exploded View

INFOID:000000011277148

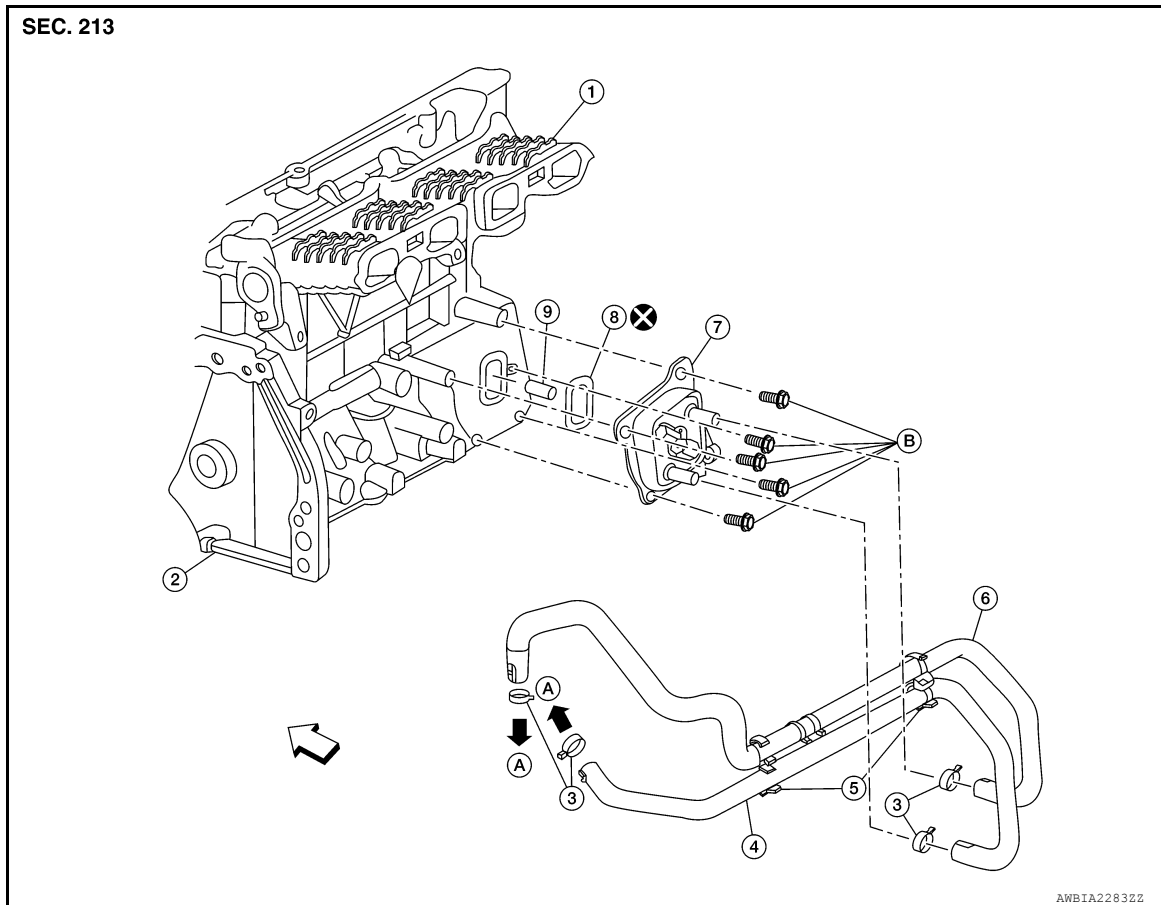

- | | | |
|--------------------|--------------------------|----------------------------|
| 1. Intake manifold | 2. Cylinder block | 3. Clamp |
| 4. Water hose | 5. Water hose clip | 6. Water hose |
| 7. Oil cooler | 8. Gasket | 9. Oil cooler relief valve |
| ⇐ Front | A. Refer to INSTALLATION | |

Removal and Installation

INFOID:000000011277149

WARNING:

Be careful not to burn yourself, as engine oil and engine coolant may be hot.

NOTE:

When removing components such as hoses, tubes/lines, etc., cap or plug openings to prevent fluid from spilling.

REMOVAL

1. Drain engine coolant. Refer to [CO-8. "Draining"](#).
2. Remove front air spoiler (RH). Refer to [EXT-16. "Exploded View"](#).
3. Remove fender protector (RH). Refer to [EXT-28. "FENDER PROTECTOR : Exploded View"](#).
4. Disconnect water hoses from the oil cooler.

OIL COOLER

< REMOVAL AND INSTALLATION >

5. Remove oil cooler bolts in reverse numerical order.

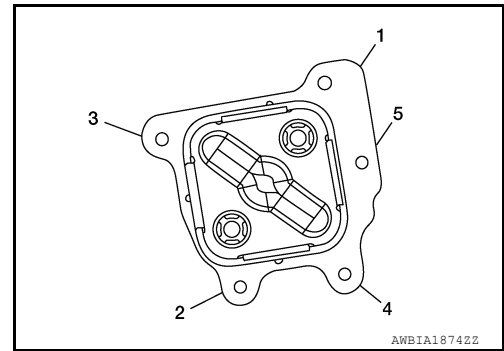

6. Remove oil cooler and gasket.

CAUTION:

- Be careful not to get burned when engine and engine oil may be hot.
- When removing, prepare a shop cloth to absorb any engine oil leaks or spillage.
- Completely wipe off any engine oil that adheres to engine and vehicle.

7. Remove relief valve.

INSTALLATION

Installation is in the reverse order of removal.

1. Tighten oil cooler to specification as shown.

Oil cooler : 9.0 N·m (0.92 kg-m, 80 in-lb)

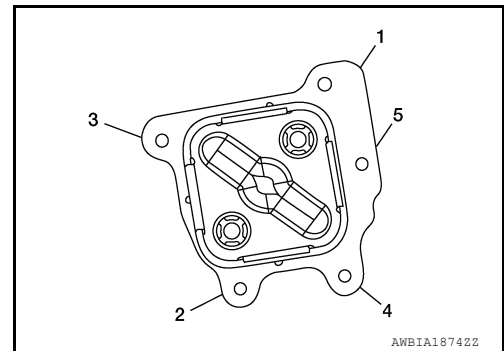

CAUTION:

- Do not reuse gasket.
- Ensure gasket and oil cooler sealing surface is free from dust, flaws, or deformation.
- Ensure water hose assembly is installed without kinks or areas of collapse.
- Replace relief valve, if removed.

Inspection

INFOID:0000000011277150

INSPECTION AFTER REMOVAL

Oil Cooler

Check oil cooler for cracks. Check oil cooler for clogging by blowing through engine coolant inlet. If necessary, replace oil cooler.

Relief valve

Inspect relief valve for movement, cracks, and breaks by pushing the ball. If replacement is necessary, remove the valve by prying it out using a suitable tool. Install a new valve by tapping it in place.

INSPECTION AFTER INSTALLATION

1. Check the engine oil level and the engine coolant level and add engine oil and engine coolant. Refer to [LU-7, "Inspection"](#) and [CO-8, "Inspection"](#).
2. Start the engine, and check that there are no leaks of engine oil or engine coolant.
3. Stop the engine and wait for 5 minutes.
4. Check the engine oil level and the engine coolant level again. Refer to [LU-7, "Inspection"](#) and [CO-8, "Inspection"](#).

OIL PUMP

< REMOVAL AND INSTALLATION >

OIL PUMP

Exploded View

INFOID:000000011277151

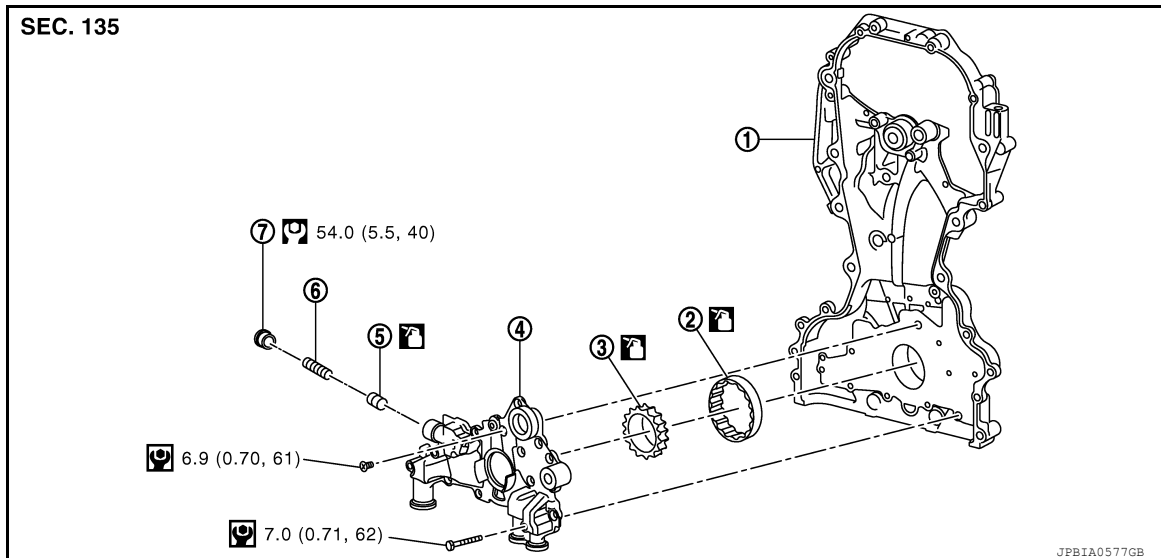

- | | | |
|---------------------------------------|--------------------|---------------------------|
| 1. Front cover (Oil pump body united) | 2. Outer rotor | 3. Inner rotor |
| 4. Oil pump cover | 5. Regulator valve | 6. Regulator valve spring |
| 7. Regulator valve plug | | |

CAUTION:

Before assembly, apply new engine oil to the parts as shown above.

Removal and Installation

INFOID:000000011277152

REMOVAL

Remove front cover. Refer to [EM-49, "Exploded View"](#).

NOTE:

Oil pump is built into front cover.

INSTALLATION

Installation is in the reverse order of removal.

- When installing, align crankshaft flat faces with inner rotor flat faces.

Disassembly and Assembly

INFOID:000000011277153

DISASSEMBLY

1. Remove bolts and oil pump cover.
2. Remove inner rotor and outer rotor from front cover.
3. After removing regulator valve plug, remove regulator valve spring and regulator valve.

ASSEMBLY

Assembly is in the reverse order of disassembly.

OIL PUMP

< REMOVAL AND INSTALLATION >

- Install the inner rotor and outer rotor with the punched marks on the oil pump cover side.

CAUTION:

Before assembly apply new engine oil to the parts specified.

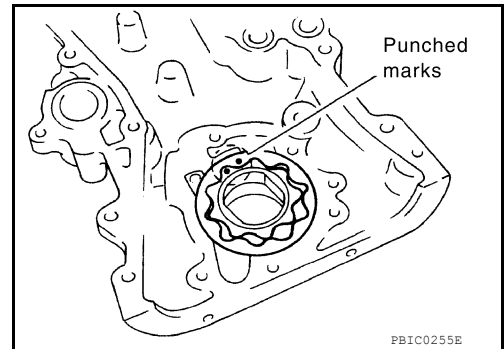

Inspection

INFOID:000000011277154

INSPECTION AFTER DISASSEMBLY

OIL PUMP CLEARANCE

- Measure the clearance using a suitable tool (A).
- Clearance between outer rotor (B) and front cover (C)

Standard : Refer to [LU-18, "Oil Pump"](#).

- Tip clearance between inner rotor and outer rotor (B)

Standard : Refer to [LU-18, "Oil Pump"](#).

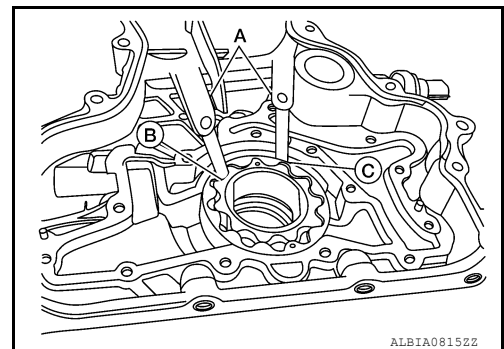

- Measure the clearance using suitable tools (A/B).
- Side clearance between inner rotor (3) and front cover (1)

Standard : Refer to [LU-18, "Oil Pump"](#).

- Side clearance between outer rotor (2) and front cover (1)

Standard : Refer to [LU-18, "Oil Pump"](#).

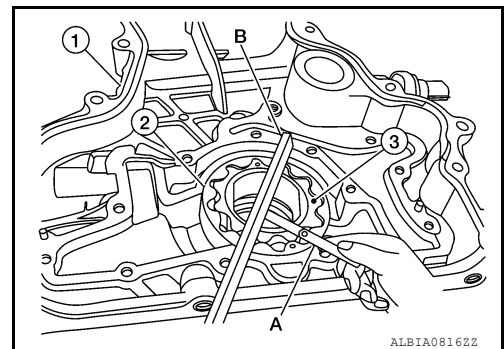

- Calculate the clearance between oil pump inner rotor and oil pump body as follows:

- Measure the outer diameter of protruded portion of inner rotor (1) using a suitable tool (A).

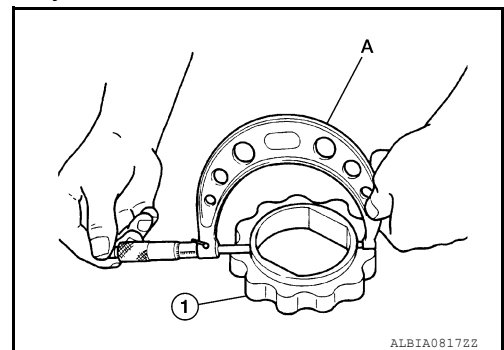

OIL PUMP

< REMOVAL AND INSTALLATION >

- Measure the inner diameter of inner rotor (1) using a suitable tool (A).

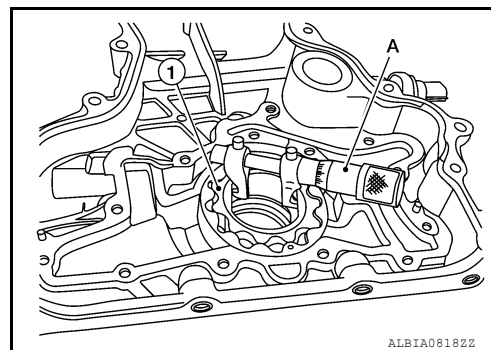

- (Clearance) = (Inner rotor inner diameter) – (Oil pump inner rotor outer diameter)

Standard : Refer to [LU-18, "Oil Pump"](#).

- If measured/calculated values are out of the standard, replace front cover and oil pump assembly.

REGULATOR VALVE TO OIL PUMP COVER CLEARANCE

- (Clearance) = (Regulator valve hole (1) diameter) – (Regulator valve (2) outer diameter)

Standard : Refer to [LU-18, "Oil Pump"](#).

- If the calculated value is out of the standard, replace front cover and oil pump assembly.

CAUTION:

- Coat regulator valve with engine oil.
- Make sure that it falls smoothly into valve hole by its own weight.

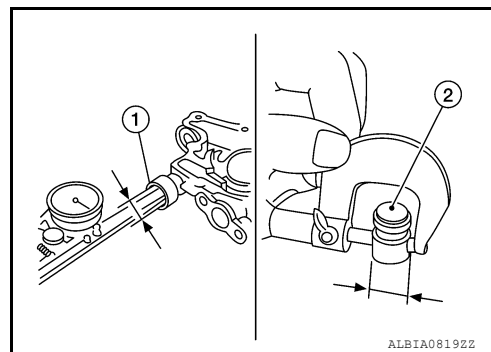

INSPECTION AFTER INSTALLATION

- Before starting engine, check oil/fluid levels including engine coolant and engine oil. If less than required quantity, fill to the specified level. Refer to [MA-11, "Fluids and Lubricants"](#).
- Use procedure below to check for fuel leaks.
- Turn ignition switch ON (with engine stopped). With fuel pressure applied to fuel piping, check for fuel leaks at connection points.
- Start engine. With engine speed increased, check again for fuel leaks at connection points.
- Run engine to check for unusual noise and vibration.

NOTE:

If hydraulic pressure inside timing chain tensioner drops after removal and installation, slack in the guide may generate a pounding noise during and just after engine start. However, this is normal. Noise will stop after hydraulic pressure rises.

- Warm up engine thoroughly to make sure there are no leaks of fuel, exhaust gas, or any oils/fluids including engine oil and engine coolant.
- Bleed air from passages in lines and hoses, such as in cooling system.
- After cooling down engine, again check oil/fluid levels including engine oil and engine coolant. Refill to specified level, if necessary.
- Summary of the inspection items:

Item		Before starting engine	Engine running	After engine stopped
Engine coolant		Level	Leakage	Level
Engine oil		Level	Leakage	Level
Transmission/transaxle fluid	A/T and CVT Models	Leakage	Level/Leakage	Leakage
	M/T Models	Level/Leakage	Leakage	Level/Leakage
Other oils and fluids*		Level	Leakage	Level
Fuel		Leakage	Leakage	Leakage
Exhaust gas		—	Leakage	—

OIL PUMP

< REMOVAL AND INSTALLATION >

*Power steering fluid, brake fluid, etc.

A

LU

C

D

E

F

G

H

I

J

K

L

M

N

O

P

SERVICE DATA AND SPECIFICATIONS (SDS)

< SERVICE DATA AND SPECIFICATIONS (SDS)

SERVICE DATA AND SPECIFICATIONS (SDS)

SERVICE DATA AND SPECIFICATIONS (SDS)

Oil Pressure

INFOID:0000000011277155

Unit: kPa (kg/cm², psi)

Engine speed	Approximate discharge oil pressure*
Idle speed	98 (1.0, 14.2)
2,000 rpm	294 (3.0, 42.6)
6,000 rpm	392 (4.0, 56.8)

*: Engine oil temperature at 80°C (176°F)

Oil Pump

INFOID:0000000011277156

Unit: mm (in)

Clearance between outer rotor and oil pump body	0.114 - 0.179 (0.0045 - 0.0070)
Tip clearance between inner rotor and outer rotor	0.170 - 0.220 (0.0067 - 0.0087)
Side clearance between inner rotor and oil pump body	0.030 - 0.070 (0.0012 - 0.0028)
Side clearance between outer rotor and oil pump body	0.060 - 0.110 (0.0024 - 0.0043)
Inner rotor to brazed portion of housing clearance	0.035 - 0.070 (0.0014 - 0.0028)

Relief Valve

INFOID:0000000011277157

Unit: mm (in)

Relief valve to oil pump cover clearance	0.040 - 0.097 (0.0016 - 0.0038)
--	---------------------------------

Oil Capacity

INFOID:0000000011277158

Unit: ℓ (US qt, Imp qt)

Drain and refill	With oil filter change	Approximately 4.6 (4-7/8, 4)
	Without oil filter change	Approximately 4.3 (4-1/2, 3-3/4)
Dry engine (engine overhaul)		Approximately 5.3 (5-5/8, 4-5/8)