

SECTION **SR**
SRS AIRBAG

A
B
C
D
E
F
G
SR
I
J
K
L
M
N
O
P

CONTENTS

PRECAUTION	2	Removal and Installation	15
PRECAUTIONS	2	FRONT PASSENGER AIR BAG MODULE	17
Precaution for Supplemental Restraint System (SRS) "AIR BAG" and "SEAT BELT PRE-TENSIONER"	2	Exploded View	17
Service	2	Removal and Installation	17
Precaution for Work	2	SIDE CURTAIN AIR BAG MODULE	19
PREPARATION	4	Exploded View	19
PREPARATION	4	Removal and Installation	19
Special Service Tools	4	FRONT SIDE AIR BAG MODULE	21
BASIC INSPECTION	5	Removal and Installation	21
COLLISION DIAGNOSIS	5	CRASH ZONE SENSOR	22
FOR FRONTAL COLLISION	5	Exploded View	22
FOR FRONTAL COLLISION : When SRS is activated in a collision	5	Removal and Installation	22
FOR FRONTAL COLLISION : When SRS is not activated in a collision	6	SIDE AIR BAG (SATELLITE) SENSOR	23
FOR SIDE AND ROLLOVER COLLISION	7	Exploded View	23
FOR SIDE AND ROLLOVER COLLISION : When SRS is activated in a collision	7	Removal and Installation	24
FOR SIDE AND ROLLOVER COLLISION : When SRS is not activated in a collision	9	AIR BAG DIAGNOSIS SENSOR UNIT	26
REMOVAL AND INSTALLATION	12	Exploded View	26
DRIVER AIR BAG MODULE	12	Removal and Installation	26
Exploded View	12	FRONT SEAT BELT PRE-TENSIONER	28
Removal and Installation	12	Removal and Installation	28
SPIRAL CABLE	15	FRONT SEAT BELT BUCKLE SWITCH	29
Exploded View	15	Removal and Installation	29
		OCCUPANT CLASSIFICATION SYSTEM	30
		Removal and Installation	30
		FRONT PASSENGER AIR BAG OFF INDICATOR	33
		Removal and Installation	33

PRECAUTIONS

< PRECAUTION >

PRECAUTION

PRECAUTIONS

Precaution for Supplemental Restraint System (SRS) "AIR BAG" and "SEAT BELT PRE-TENSIONER"

INFOID:000000011279746

The Supplemental Restraint System such as "AIR BAG" and "SEAT BELT PRE-TENSIONER", used along with a front seat belt, helps to reduce the risk or severity of injury to the driver and front passenger for certain types of collision. Information necessary to service the system safely is included in the SR and SB section of this Service Manual.

WARNING:

- To avoid rendering the SRS inoperative, which could increase the risk of personal injury or death in the event of a collision which would result in air bag inflation, all maintenance must be performed by an authorized NISSAN/INFINITI dealer.
- Improper maintenance, including incorrect removal and installation of the SRS, can lead to personal injury caused by unintentional activation of the system. For removal of Spiral Cable and Air Bag Module, see the SR section.
- Do not use electrical test equipment on any circuit related to the SRS unless instructed to in this Service Manual. SRS wiring harnesses can be identified by yellow and/or orange harnesses or harness connectors.

PRECAUTIONS WHEN USING POWER TOOLS (AIR OR ELECTRIC) AND HAMMERS

WARNING:

- When working near the Airbag Diagnosis Sensor Unit or other Airbag System sensors with the Ignition ON or engine running, DO NOT use air or electric power tools or strike near the sensor(s) with a hammer. Heavy vibration could activate the sensor(s) and deploy the air bag(s), possibly causing serious injury.
- When using air or electric power tools or hammers, always switch the Ignition OFF, disconnect the battery and wait at least three minutes before performing any service.

Service

INFOID:000000011279747

- Do not use electrical test equipment to check SRS circuits unless instructed to in this Service Manual.
- Before servicing the SRS, turn ignition switch OFF, disconnect battery negative terminal and wait at least three minutes.
For approximately three minutes after the cables are removed, it is still possible for the air bag and seat belt pre-tensioner to deploy. Therefore, do not work on any SRS connectors or wires until at least three minutes have elapsed.
- Diagnosis sensor unit must always be installed with their arrow marks "←" pointing towards the front of the vehicle for proper operation. Also check diagnosis sensor unit for cracks, deformities or rust before installation and replace as required.
- The spiral cable must be aligned in the neutral position since its rotations are limited. Do not turn steering wheel and column after removal of steering gear.
- Handle air bag module carefully. Always place driver and front passenger air bag modules with the pad side facing upward and seat mounted front side air bag module standing with the stud bolt side facing down.
- Conduct self-diagnosis to check entire SRS for proper functioning after replacing any components.
- After air bag inflates, the front instrument panel assembly should be replaced if damaged.
- Always replace instrument panel pad following front passenger air bag deployment.

Precaution for Work

INFOID:000000011279748

- When removing or disassembling each component, be careful not to damage or deform it. If a component may be subject to interference, be sure to protect it with a shop cloth.
- When removing (disengaging) components with a screwdriver or similar tool, be sure to wrap the component with a shop cloth or vinyl tape to protect it.
- Protect the removed parts with a shop cloth and prevent them from being dropped.
- Replace a deformed or damaged clip.
- If a part is specified as a non-reusable part, always replace it with a new one.
- Be sure to tighten bolts and nuts securely to the specified torque.
- After installation is complete, be sure to check that each part works properly.

PRECAUTIONS

< PRECAUTION >

- Follow the steps below to clean components:
- Water soluble dirt:
 - Dip a soft cloth into lukewarm water, wring the water out of the cloth and wipe the dirty area.
 - Then rub with a soft, dry cloth.
- Oily dirt:
 - Dip a soft cloth into lukewarm water with mild detergent (concentration: within 2 to 3%) and wipe the dirty area.
 - Then dip a cloth into fresh water, wring the water out of the cloth and wipe the detergent off.
 - Then rub with a soft, dry cloth.
- Do not use organic solvent such as thinner, benzene, alcohol or gasoline.
- For genuine leather seats, use a genuine leather seat cleaner.

A

B

C

D

E

F

G

SR

I

J

K

L

M

N

O

P

PREPARATION

< PREPARATION >

PREPARATION

PREPARATION

Special Service Tools

INFOID:000000011279749

The actual shape of the tools may differ from those illustrated here.

Tool number (TechMate No.) Tool name	Description
— (J-46534) Trim Tool Set	Removing trim components

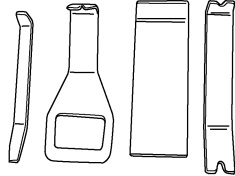

AWJIA0483ZZ

COLLISION DIAGNOSIS

< BASIC INSPECTION >

BASIC INSPECTION

COLLISION DIAGNOSIS FOR FRONTAL COLLISION

FOR FRONTAL COLLISION : When SRS is activated in a collision

INFOID:000000011279750

CAUTION:

Due to varying models and option levels, not all parts listed in the chart below apply to all vehicles.

WORK PROCEDURE

1. Before performing any of the following steps, ensure that all vehicle body and structural repairs have been completed.
2. Replace the diagnosis sensor unit.
3. Remove the front air bag modules, crash zone sensor, bracket and seat belt pre-tensioner assemblies.
4. Check the SRS components using the table below:
Replace any SRS components showing visible signs of damage. (dents, cracks and deformation, etc.)
5. Install new front air bag modules, crash zone sensor assembly, bracket and seat belt pre-tensioner assemblies.
6. Perform self-diagnosis using CONSULT or air bag warning lamp. Refer to [SRC-14, "Description"](#) for details. Ensure entire SRS operates properly.
7. After the work is completed, perform self-diagnosis to check that no malfunction is detected. Refer to [SRC-14, "Description"](#).

SRS INSPECTION (FOR FRONTAL COLLISION)

Part	Inspection
Driver air bag module	If the driver air bag has deployed: REPLACE Install with new fasteners.
Front passenger air bag module (if equipped)	If the front passenger air bag has deployed: REPLACE Install with new fasteners.
Crash zone sensor	If any of the front air bags or seat belt pre-tensioners* have been activated: REPLACE the crash zone sensor and bracket with new fasteners. *: Confirm seat belt pre-tensioner activation using CONSULT only.
Seat belt pre-tensioner assemblies (All applicable locations: buckle, retractor, lap outer)	If either the driver or passenger seat belt pre-tensioner* has been activated: REPLACE all seat belt pre-tensioner assemblies with new fasteners. *: Confirm seat belt pre-tensioner activation using CONSULT only.
Diagnosis sensor unit	If any of the SRS components have been activated: REPLACE the diagnosis sensor unit. Install with new fasteners.
Steering wheel	<ol style="list-style-type: none"> 1. Visually check steering wheel for deformities. 2. Check harness (built into steering wheel) and connectors for damage, and terminals for deformities. 3. Install driver air bag module into the steering wheel to check fit and alignment with the wheel. 4. Check steering wheel for excessive free play. 5. If no damage is found, reinstall. 6. If damaged – REPLACE.
Spiral cable	If the driver front air bag has deployed: REPLACE the spiral cable.

COLLISION DIAGNOSIS

< BASIC INSPECTION >

Part	Inspection
Occupant classification system (Passenger seat)	<ol style="list-style-type: none"> 1. Remove passenger seat assembly. 2. Check control unit case for dents, cracks or deformities. 3. Check connectors and pressure sensor tube for damage, and terminals for deformities. 4. Check seat frame and cushion pan for dents or deformities. 5. If no damage is found, reinstall seat with new fasteners. 6. If damaged – REPLACE seat cushion assembly with new fasteners. 7. Perform zero point reset function after front passenger seat is installed in the vehicle and all bolts are tightened to specification. Refer to SRC-41, "ZERO POINT RESET : Description".
Harness and connectors	<ol style="list-style-type: none"> 1. Check connectors for poor connection, damage, and terminals for deformities. 2. Check harness for binding, chafing, cuts, or deformities. 3. If no damage is found, reinstall the harness and connectors. 4. If damaged – REPLACE the damaged harness. Do not attempt to repair, splice or modify any SRS harness.
Instrument panel assembly	If the front passenger air bag has deployed: REPLACE the instrument panel assembly. (integrated type)

FOR FRONTAL COLLISION : When SRS is not activated in a collision

INFOID:000000011279751

CAUTION:

Due to varying models and option levels, not all parts listed in the chart below apply to all vehicles.

WORK PROCEDURE

1. Before performing any of the following steps, ensure that all vehicle body and structural repairs have been completed.
2. Check the SRS components using the table below:
Replace any SRS components showing visible signs of damage. (dents, cracks and deformation, etc.)
3. Perform self-diagnosis using CONSULT or air bag warning lamp. Refer to [SRC-14, "Description"](#) for details. Ensure entire SRS operates properly.
4. After the work is completed, perform self-diagnosis to check that no malfunction is detected. Refer to [SRC-14, "Description"](#).

SRS INSPECTION (FOR FRONTAL COLLISION)

Part	Inspection
Driver air bag module	<p>If the driver air bag has NOT been deployed:</p> <ol style="list-style-type: none"> 1. Remove driver air bag module. Check harness cover and connectors for damage, terminals for deformities, and harness for binding. 2. Install driver air bag module into the steering wheel to check fit and alignment with the wheel. 3. If no damage is found, reinstall with new fasteners. 4. If damaged – REPLACE. Install driver air bag module with new fasteners.
Front passenger air bag module (if equipped)	<p>If the front passenger air bag has NOT been deployed:</p> <ol style="list-style-type: none"> 1. Remove front passenger air bag module. Check harness cover and connectors for damage, terminals for deformities, and harness for binding. 2. Install front passenger air bag module into the instrument panel to check fit with the instrument panel. 3. If no damage is found, reinstall with new fasteners. 4. If damaged – REPLACE. Install front passenger air bag modules with new fasteners.
Crash zone sensor	<p>If the front air bags or seat belt pre-tensioners have NOT been activated:</p> <ol style="list-style-type: none"> 1. Remove the crash zone sensor. Check harness connectors for damage, terminals for deformities, and harness for binding. 2. Check for visible signs of damage (dents, cracks, deformation, etc.) of the crash zone sensor and bracket. 3. Install the crash zone sensor to check fit. 4. If no damage is found, reinstall with new fasteners. 5. If damaged – REPLACE the crash zone sensor and bracket with new fasteners.

COLLISION DIAGNOSIS

< BASIC INSPECTION >

Part	Inspection	
Seat belt pre-tensioner assemblies (All applicable locations: buckle, retractor, lap outer)	<p>If the pre-tensioners have NOT been activated:</p> <ol style="list-style-type: none"> Remove seat belt pre-tensioners. Check harness cover and connectors for damage, terminals for deformities, and harness for binding. Check belts for damage and anchors for loose mounting. Check retractor for smooth operation. Check seat belt adjuster for damage. Check for deformities of the center pillar inner. If the center pillar inner has no damage, REPLACE the seat belt pre-tensioner assembly. If no damage is found, reinstall seat belt pre-tensioner assembly. If damaged – REPLACE. Install the seat belt pre-tensioners with new fasteners. 	A B C D
Diagnosis sensor unit	<p>If none of the SRS components have been activated:</p> <ol style="list-style-type: none"> Check case for dents, cracks or deformities. Check connectors for damage, and terminals for deformities. If no damage is found, reinstall with new fasteners. If damaged – REPLACE. Install diagnosis sensor unit with new fasteners. 	E
Steering wheel	<ol style="list-style-type: none"> Visually check steering wheel for deformities. Check harness (built into steering wheel) and connectors for damage, and terminals for deformities. Install driver air bag module into the steering wheel to check fit and alignment with the wheel. Check steering wheel for excessive free play. If no damage is found, reinstall. If damaged – REPLACE. 	F G
Spiral cable	<p>If the driver front air bag has not deployed:</p> <ol style="list-style-type: none"> Visually check spiral cable and combination switch for damage. Check connectors and protective tape for damage. Check steering wheel for noise, binding or heavy operation. If no damage is found, reinstall. If damaged – REPLACE. 	SR
Occupant classification system (Passenger seat)	<ol style="list-style-type: none"> Remove passenger seat assembly. Check control unit case for dents, cracks or deformities. Check connectors and pressure sensor tube for damage, and terminals for deformities. Check seat frame and cushion pan for dents or deformities. If no damage is found, reinstall seat with new fasteners. If damaged – REPLACE seat cushion assembly with new fasteners. Perform zero point reset function after front passenger seat is installed in the vehicle and all bolts are tightened to specification. Refer to SRC-41, "ZERO POINT RESET : Description". 	I J K
Harness and connectors	<ol style="list-style-type: none"> Check connectors for poor connection, damage, and terminals for deformities. Check harness for binding, chafing, cuts, or deformities. If no damage is found, reinstall the harness and connectors. If damaged – REPLACE the damaged harness. Do not attempt to repair, splice or modify any SRS harness. 	L
Instrument panel assembly	<p>If the front passenger air bag has NOT deployed:</p> <ol style="list-style-type: none"> Visually check instrument panel assembly for damage. If no damage is found, reinstall the instrument panel assembly. If damaged – REPLACE the instrument panel assembly. 	M N

FOR SIDE AND ROLLOVER COLLISION

FOR SIDE AND ROLLOVER COLLISION : When SRS is activated in a collision

INFOID:000000011279752

CAUTION:

Due to varying models and option levels, not all parts listed in the chart below apply to all vehicles.

WORK PROCEDURE

- Before performing any of the following steps, ensure that all vehicle body and structural repairs have been completed.
- Replace the following components:
 - Front seat back assembly (on the side on which side air bag is activated)
 - Door finisher (on the side on which door-mounted curtain air bag is activated)
 - Pop-up roll bar assemblies and pop-up roll bar covers

COLLISION DIAGNOSIS

< BASIC INSPECTION >

- Side air bag (satellite) sensor LH/RH (on the side on which side air bag is activated)
 - Diagnosis sensor unit
 - Seat belt pre-tensioner assemblies
3. Check the SRS components and the related parts using the following table.
Replace any SRS components and the related parts showing visible signs of damage. (dents, cracks, deformation, etc.)
 4. Perform self-diagnosis using CONSULT and “AIR BAG” warning lamp. Refer to [SRC-14, "Description"](#) for details. Make sure entire SRS operates properly.
 5. After the work is completed, perform self-diagnosis to check that no malfunction is detected. Refer to [SRC-14, "Description"](#).

SRS INSPECTION (FOR SIDE AND ROLLOVER COLLISION)

Part	Inspection
Side curtain air bag module LH	If the side curtain air bag LH has deployed: REPLACE the side curtain air bag module LH. Install with new fasteners.
Side curtain air bag module RH	If the side curtain air bag RH has deployed: REPLACE the side curtain air bag module RH. Install with new fasteners.
Front side air bag module LH	If the front side air bag LH has deployed: REPLACE front seatback assembly LH.
Front side air bag module RH	If the front side air bag RH has deployed: REPLACE front seatback assembly RH.
Side air bag (satellite) sensor (LH or RH)	If any of the SRS components have deployed: REPLACE the side air bag (satellite) sensor on the collision side with new fasteners.
Door (satellite) sensor (LH or RH)	If any of the SRS components have deployed: REPLACE the door (satellite) sensor on the collision side with new fasteners.
Diagnosis sensor unit	If any of the SRS components have deployed: REPLACE the diagnosis sensor unit with new fasteners.
Seat belt pre-tensioner assemblies (All applicable locations: buckle, retractor, lap outer)	If either the driver or passenger seat belt pre-tensioner* has been activated: REPLACE all seat belt pre-tensioner assemblies with new fasteners. *: Confirm seat belt pre-tensioner activation using CONSULT only.
Center inner pillar	<ol style="list-style-type: none"> 1. Check the center inner pillar on the collision side for damage (dents, cracks, deformation, etc.). 2. If damaged – REPAIR the center inner pillar.
Trim/headlining	<ol style="list-style-type: none"> 1. Check for visible signs of damage (dents, cracks, deformation, etc.) of the interior trim on the collision side. 2. If damaged – REPLACE the damaged trim parts.
Door-mounted curtain air bag module LH	If the door-mounted curtain air bag module LH has deployed: REPLACE the door finisher LH and door-mounted curtain air bag module. Install with new fasteners.
Door-mounted curtain air bag module RH	If the door-mounted curtain air bag module RH has deployed: REPLACE the door finisher RH and door-mounted curtain air bag module. Install with new fasteners.
Occupant classification system (Passenger seat)	<ol style="list-style-type: none"> 1. Remove passenger seat assembly. 2. Check control unit case for dents, cracks or deformities. 3. Check connectors and pressure sensor tube for damage, and terminals for deformities. 4. Check seat frame and cushion pan for dents or deformities. 5. If no damage is found, reinstall seat with new fasteners. 6. If damaged – REPLACE seat cushion assembly with new fasteners. 7. Perform zero point reset function after front passenger seat is installed in the vehicle and all bolts are tightened to specification. Refer to SRC-41, "ZERO POINT RESET : Description".
Pop-up roll bar assemblies	If the pop-up roll bar has deployed: REPLACE pop-up roll bar assemblies and pop-up roll bar covers. Install with new fasteners.

COLLISION DIAGNOSIS

< BASIC INSPECTION >

FOR SIDE AND ROLLOVER COLLISION : When SRS is not activated in a collision

INFOID:0000000011279753

CAUTION:

Due to varying models and option levels, not all parts listed in the chart below apply to all vehicles.

WORK PROCEDURE

1. Before performing any of the following steps, ensure that all vehicle body and structural repairs have been completed.
2. Check the SRS components and the related parts using the following table.
 - If the front seat back assembly is damaged, the front seat back assembly must be replaced.
 - If the door finisher assembly is damaged, the door finisher assembly and door-mounted curtain air bag module must be replaced.
3. Perform self-diagnosis using CONSULT and "AIR BAG" warning lamp. Refer to [SRC-14, "Description"](#) for details. Make sure entire SRS operates properly.
4. After the work is completed, perform self-diagnosis to check that no malfunction is detected. Refer to [SRC-14, "Description"](#).

SRS INSPECTION (FOR SIDE AND ROLLOVER COLLISION)

Part	Inspection
Side curtain air bag module LH	If the side curtain air bag LH has NOT deployed: <ol style="list-style-type: none"> 1. Check for visible signs of damage (dents, tears, deformation, etc.) of the center pillar on the collision side. 2. If damaged – Remove the side curtain air bag module LH. 3. Check for visible signs of damage (tears etc.) of the side curtain air bag module LH. 4. Check harness and connectors for damage, and terminals for deformities. 5. If no damage is found, reinstall the side curtain air bag module LH with new fasteners. 6. If damaged – REPLACE the side curtain air bag module LH with new fasteners.
Side curtain air bag module RH	If the side curtain air bag RH has NOT deployed: <ol style="list-style-type: none"> 1. Check for visible signs of damage (dents, tears, deformation, etc.) of the center pillar on the collision side. 2. If damaged – Remove the side curtain air bag module RH. 3. Check for visible signs of damage (tears etc.) of the side curtain air bag module RH. 4. Check harness and connectors for damage, and terminals for deformities. 5. If no damage is found, reinstall the side curtain air bag module RH with new fasteners. 6. If damaged – REPLACE the side curtain air bag module RH with new fasteners.
Front side air bag module LH	If the front side air bag LH has NOT deployed: <ol style="list-style-type: none"> 1. Check for visible signs of damage (dents, tears, deformation, etc.) of the seat back on the collision side. 2. Check harness and connectors for damage, and terminals for deformities. 3. If damaged – REPLACE the front seatback assembly LH.
Front side air bag module RH	If the front side air bag RH has NOT deployed: <ol style="list-style-type: none"> 1. Check for visible signs of damage (dents, tears, deformation, etc.) of the seat back on the collision side. 2. Check harness and connectors for damage, and terminals for deformities. 3. If damaged – REPLACE the front seatback assembly RH.
Side air bag (satellite) sensor (LH or RH)	If none of the SRS components have been activated: <ol style="list-style-type: none"> 1. Remove the side air bag (satellite) sensor (LH or RH) on the collision side. Check harness connectors for damage, terminals for deformities, and harness for binding. 2. Check for visible signs of damage (dents, cracks, deformation, etc.) of the side air bag (satellite) sensor (LH or RH). 3. Install the side air bag (satellite) sensor (LH or RH) to check fit. 4. If no damage is found, reinstall the side air bag (satellite) sensor (LH or RH) with new fasteners. 5. If damaged – REPLACE the side air bag (satellite) sensor (LH or RH) with new fasteners.

A
B
C
D
E
F
G
I
J
K
L
M
N
O
P

SR

COLLISION DIAGNOSIS

< BASIC INSPECTION >

Part	Inspection
Door (satellite) sensor (LH or RH)	<p>If none of the SRS components have been activated:</p> <ol style="list-style-type: none"> 1. Remove the door (satellite) sensor (LH or RH) on the collision side. Check harness connectors for damage, terminals for deformities, and harness for binding. 2. Check for visible signs of damage (dents, cracks, deformation, etc.) of the door (satellite) sensor (LH or RH). 3. Install the door (satellite) sensor (LH or RH) to check fit. 4. If no damage is found, reinstall the door (satellite) sensor (LH or RH) with new fasteners. 5. If damaged – REPLACE the door (satellite) sensor (LH or RH) with new fasteners.
Diagnosis sensor unit	<p>If none of the SRS components have been activated:</p> <ol style="list-style-type: none"> 1. Check case and bracket for dents, cracks or deformities. 2. Check connectors for damage, and terminals for deformities. 3. If no damage is found, reinstall the diagnosis sensor unit with new fasteners. 4. If damaged – REPLACE the diagnosis sensor unit with new fasteners.
Seat belt pre-tensioner assemblies (All applicable locations: buckle, retractor, lap outer)	<p>If the pre-tensioners have NOT been activated:</p> <ol style="list-style-type: none"> 1. Remove seat belt pre-tensioners. Check harness cover and connectors for damage, terminals for deformities, and harness for binding. 2. Check belts for damage and anchors for loose mounting. 3. Check retractor for smooth operation. 4. Check seat belt adjuster for damage. 5. Check for deformities of the center pillar inner. 6. If the center pillar inner has no damage, REPLACE the seat belt pre-tensioner assembly. 7. If no damage is found, reinstall seat belt pre-tensioner assembly. 8. If damaged – REPLACE. Install the seat belt pre-tensioners with new fasteners.
Seat (with front side air bag)	<p>If the front LH or front RH side air bag modules have NOT deployed:</p> <ol style="list-style-type: none"> 1. Visually check the seat on the collision side. 2. Remove the seat on the collision side and check the following for damage and deformities. <ul style="list-style-type: none"> - Harness, connectors and terminals - Frame and recliner (for front and rear seat), and also adjuster and slides (for front seat) 3. If no damage is found, reinstall the seat. 4. If damaged – REPLACE the damaged seat parts using new fasteners. If the front seat back is damaged, the front seat back assembly must be replaced.
Center inner pillar	<ol style="list-style-type: none"> 1. Check the center inner pillar on the collision side for damage (dents, cracks, deformation, etc.). 2. If damaged – REPAIR the center inner pillar.
Trim/headlining	<ol style="list-style-type: none"> 1. Check for visible signs of damage (dents, cracks, deformation, etc.) of the interior trim on the collision side. 2. If damaged – REPLACE the damaged trim parts.
Door-mounted curtain air bag module LH	<p>If the door-mounted curtain air bag LH has NOT deployed:</p> <ol style="list-style-type: none"> 1. Check for visible signs of damage (dents, tears, deformation, etc.) of the door finisher on the collision side. 2. If damaged – REPLACE the door finisher LH with new fasteners. 3. Check for visible signs of damaged (tears etc.) of the door-mounted curtain air bag module LH. 4. Check harness and connectors for damage, and terminals for deformities. 5. If no damage is found, reinstall door finisher. <p>CAUTION: When removing door-mounted curtain air bag module from door finisher, never reuse door finisher.</p> <ol style="list-style-type: none"> 6. If damaged – REPLACE the door finisher LH and door-mounted curtain air bag module LH with new fasteners.
Door-mounted curtain air bag module RH	<p>If the door-mounted curtain air bag RH has NOT deployed:</p> <ol style="list-style-type: none"> 1. Check for visible signs of damage (dents, tears, deformation, etc.) of the door finisher on the collision side. 2. If damaged – REPLACE the door finisher RH with new fasteners. 3. Check for visible signs of damage (tears etc.) of the door-mounted curtain air bag module RH. 4. Check harness and connectors for damage, and terminals for deformities. 5. If no damage is found, reinstall door finisher. <p>CAUTION: When removing door-mounted curtain air bag module from door finisher, never reuse door finisher.</p> <ol style="list-style-type: none"> 6. If damaged – REPLACE the door finisher RH and door-mounted curtain air bag module RH with new fasteners.

COLLISION DIAGNOSIS

< BASIC INSPECTION >

Part	Inspection	
Occupant classification system (Passenger seat)	1. Remove passenger seat assembly.	A
	2. Check control unit case for dents, cracks or deformities.	
	3. Check connectors and pressure sensor tube for damage, and terminals for deformities.	
	4. Check seat frame and cushion pan for dents or deformities.	B
	5. If no damage is found, reinstall seat with new fasteners.	
	6. If damaged – REPLACE seat cushion assembly with new fasteners.	
	7. Perform zero point reset function after front passenger seat is installed in the vehicle and all bolts are tightened to specification. Refer to SRC-41, "ZERO POINT RESET : Description" .	C
Pop-up roll bar	If the pop-up roll bar has NOT deployed:	
	1. Check for visible signs of damage (dents, tears, deformation, etc.) of the pop-up roll bar.	D
	2. If damaged – REPLACE the pop-up roll bar with new fasteners.	
	3. Check harness and connectors for damage, and terminals for deformities.	
	4. If no damage is found, reinstall the pop-up roll bar with new fasteners.	
	5. Check for visible signs of damage (dents, cracks, deformation, etc.) of the seatback support brace assembly.	E
6. If damaged – REPAIR the seatback support brace assembly.		

A
B
C
D
E
F
G
I
J
K
L
M
N
O
P

SR

DRIVER AIR BAG MODULE

< REMOVAL AND INSTALLATION >

REMOVAL AND INSTALLATION

DRIVER AIR BAG MODULE

Exploded View

INFOID:000000011279754

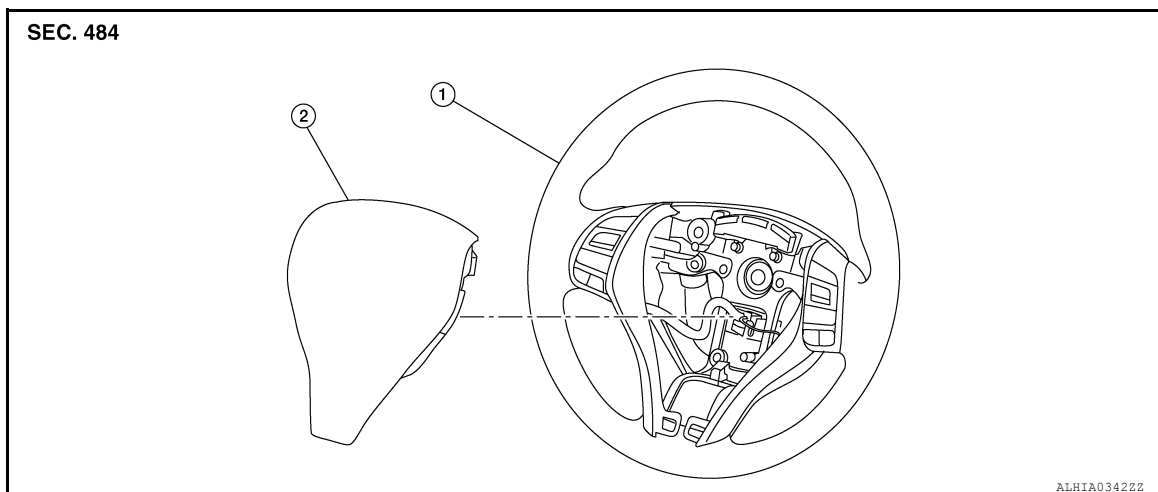

1. Steering wheel

2. Driver air bag module

Removal and Installation

INFOID:000000011279755

WARNING:

- Before servicing the SRS, turn ignition switch OFF, disconnect both battery terminals then wait at least three minutes.
- Always work from the side of driver air bag module. Do not work in front of it.
- Do not use the air tools or electric tools for servicing.

REMOVAL

1. Disconnect negative and positive battery terminals, then wait at least three minutes. Refer to [PG-80](#), "Removal and Installation".
2. Release driver air bag module hooks.

DRIVER AIR BAG MODULE

< REMOVAL AND INSTALLATION >

- a. Locate the access hole on RH side of steering wheel rear finisher (1) and insert (←) a 5.0 mm (0.20 in) diameter suitable tool (A).
- b. Push suitable tool (A) inward (←) and make sure the tool contacts the spring (2) as shown. Push on the upper right of the driver air bag module while pressing on the spring to release the driver air bag module hook (RH). Repeat procedure for driver air bag module hook (LH).

NOTE:

Driver air bag module removed for clarity.

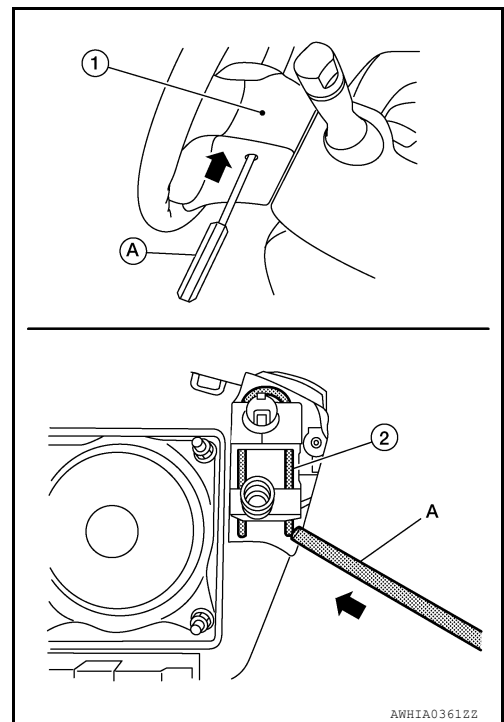

3. Lift driver air bag module as shown, then disconnect harness connectors from the driver air bag module.

CAUTION:

- For installing/removing the driver air bag module harness connector, insert thin screwdriver wrapped in tape into notch, lift lock and remove the connector.
- Install the connector with lock raised, and push lock into the connector.
- After installing the connector, check that the lock is pushed securely into it.

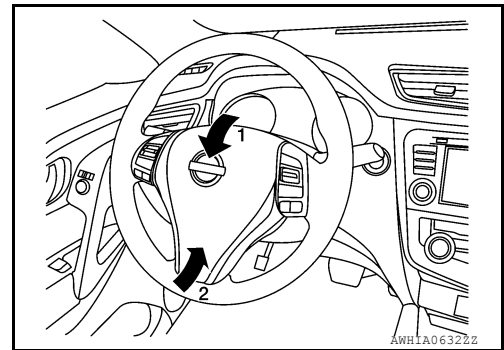

4. Remove the driver air bag module.

CAUTION:

- Always place the driver air bag module with pad side facing upward.

↕: Upward

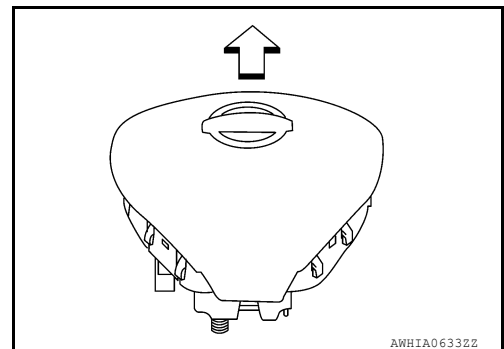

DRIVER AIR BAG MODULE

< REMOVAL AND INSTALLATION >

- Do not strike or impact the driver air bag module.
- Replace the driver air bag module if it has been dropped or sustained an impact.



- Do not insert any foreign objects (screwdriver, etc.) into the driver air bag module.
- Do not disassemble the driver air bag module.
- Do not expose the driver air bag module to temperatures exceeding 93°C (199°F).
- Do not allow oil, grease, detergent, or water to come in contact with the driver air bag module.

INSTALLATION

Installation is in the reverse order of removal.

CAUTION:

- Always connect the driver air bag module harnesses (A) and route through the hook (B) as shown.

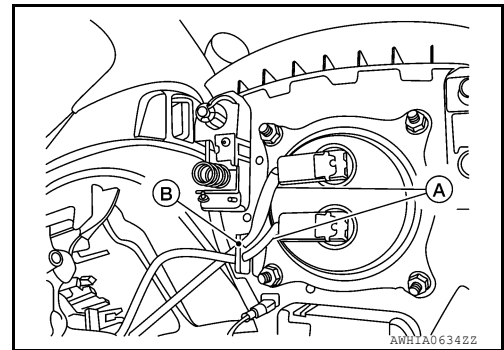

- If driver air bag module is being replaced due to deployment, the spiral cable must also be replaced. Refer to [SR-15, "Removal and Installation"](#).
- Do not pinch or damage the harnesses while installing.
- If a malfunction is indicated by the air bag warning lamp after repair or replacement of the malfunctioning parts, perform the SRS Final Check. Refer to [SRC-16, "Trouble Diagnosis with CONSULT"](#).
- After installation is complete, check that no system malfunction is detected causing the air bag warning lamp to illuminate.

SPIRAL CABLE

< REMOVAL AND INSTALLATION >

SPIRAL CABLE

Exploded View

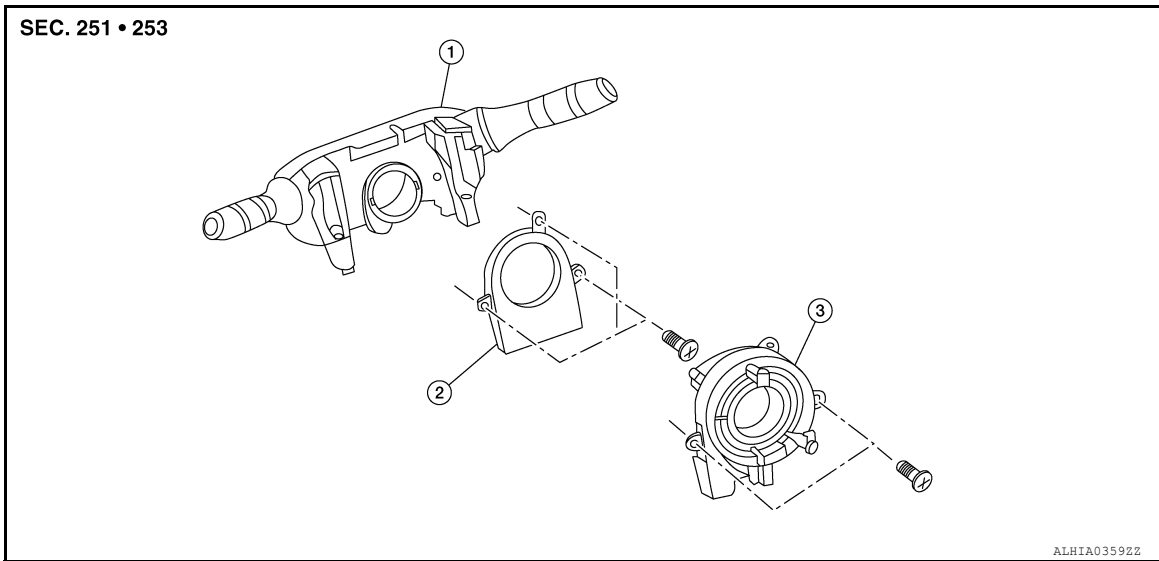

1. Combination switch 2. Steering angle sensor 3. Spiral cable

Removal and Installation

INFOID:000000011279757

SR

WARNING:

- Before servicing the SRS, turn ignition switch OFF, disconnect both battery terminals then wait at least three minutes.
- Do not use the air tools or electric tools for servicing.

REMOVAL

1. Disconnect the negative and positive battery terminals, then wait at least three minutes. Refer to [PG-80, "Removal and Installation"](#).
2. Remove the steering wheel. Refer to [ST-11, "Removal and Installation"](#).
3. Remove the steering column upper and lower cover. Refer to [JP-18, "Removal and Installation"](#).
4. Disconnect harness connectors (A).

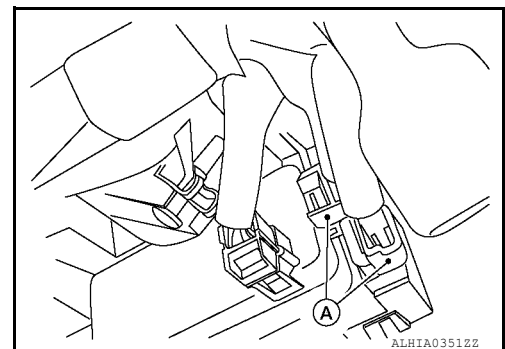

5. Remove screws (A) and then remove spiral cable (1).

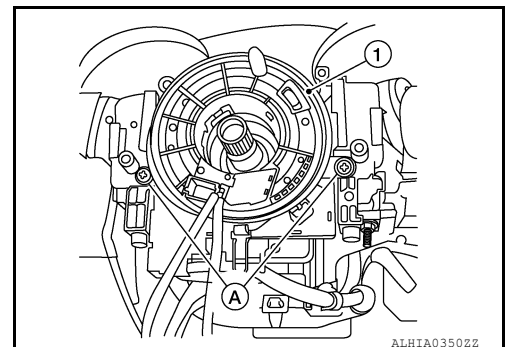

SPIRAL CABLE

< REMOVAL AND INSTALLATION >

CAUTION:

- Do not strike or drop the spiral cable.
- Do not turn the spiral cable quickly or beyond the limit number of turns (approximately 2.5 turns from the neutral position), this may cause the cable to snap.
- Replace the spiral cable if it has been dropped or sustained an impact.
- Do not disassemble the spiral cable.
- Do not allow oil, grease, detergent, or water to come in contact with the spiral cable.



INSTALLATION

Installation is in the reverse order of removal.

- The turn signal lever must be in the neutral position for spiral cable installation.
- Set the spiral cable neutral position by carefully turning the spiral cable clockwise to the end position. Turn the spiral cable counter-clockwise 2.5 turns stopping when the locating pin (B) is at the top most position and confirm that a yellow indicator with a vertical black line will be shown in the window (A).

NOTE:

If a new service part is installed, the neutral position is already set with a stopper clip in place and should not be adjusted after the stopper clip is removed. Make sure the stopper is removed before installing the steering wheel.

- During steering wheel installation, make sure the locating pin hole is aligned with the locating pin (B) of the spiral cable.
- Adjust the neutral position of the steering angle sensor. Refer to [BRC-68. "Work Procedure"](#).

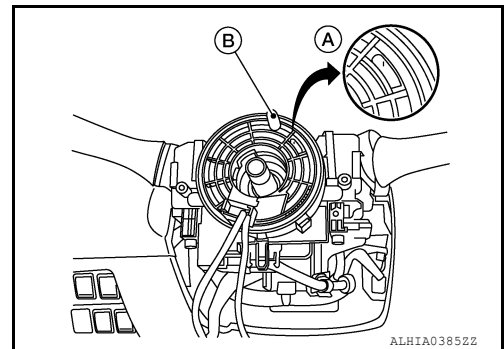

CAUTION:

- The spiral cable may snap during steering operation if the spiral cable is installed in an improper position.
- Do not overturn the spiral cable or go beyond the maximum number of turns allowed. This will cause the cable to snap.
- The turn signal lever must be in the neutral position for spiral cable installation.
- Do not apply lubricant to the spiral cable.
- Do not allow oil, grease, detergent or water to come in contact with the spiral cable.
- After installation is complete, check that no system malfunction is detected causing the air bag warning lamp to illuminate.
- If a malfunction is indicated by the air bag warning lamp after repair or replacement of the malfunctioning parts, perform the SRS Final Check. Refer to [SRC-16. "Trouble Diagnosis with CONSULT"](#).

FRONT PASSENGER AIR BAG MODULE

< REMOVAL AND INSTALLATION >

FRONT PASSENGER AIR BAG MODULE

Exploded View

INFOID:000000011279758

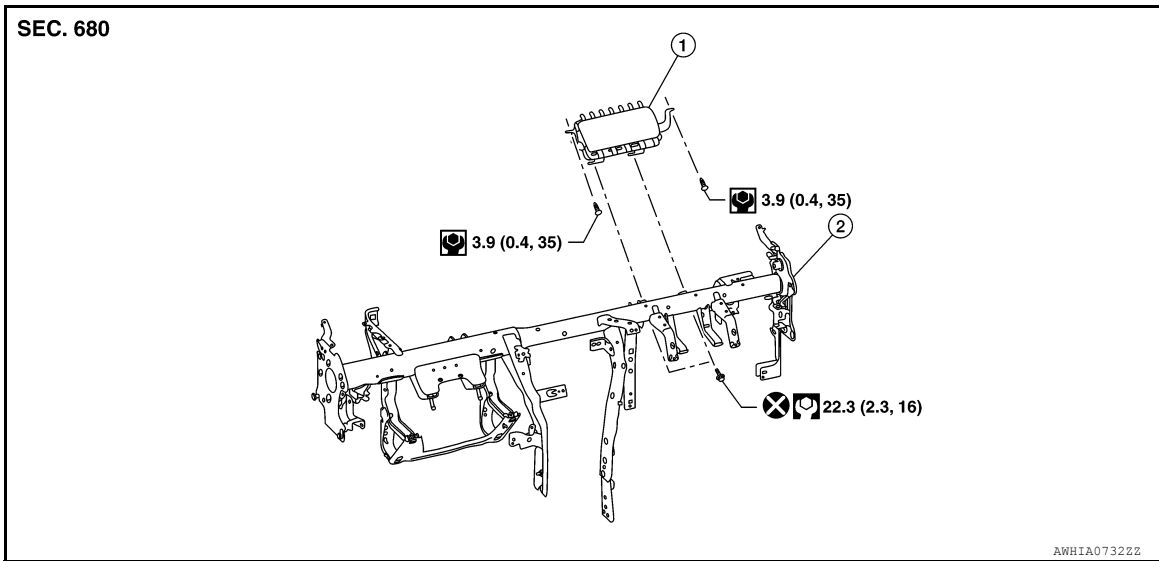

1. Front passenger air bag module 2. Steering member

Removal and Installation

INFOID:000000011279759

SR

WARNING:

- Before servicing the SRS, turn ignition switch OFF, disconnect both battery terminals then wait at least three minutes.
- Always work from the side of air bag module. Do not work in front of it.
- Do not use air tools or electric tools for servicing.

REMOVAL

1. Remove the Instrument panel assembly. Refer to [IP-14, "INSTRUMENT PANEL ASSEMBLY : Removal and Installation"](#).
2. Remove front passenger air bag module screws.
3. Release the pawls by removing the front passenger air bag module as shown.

○: Pawl

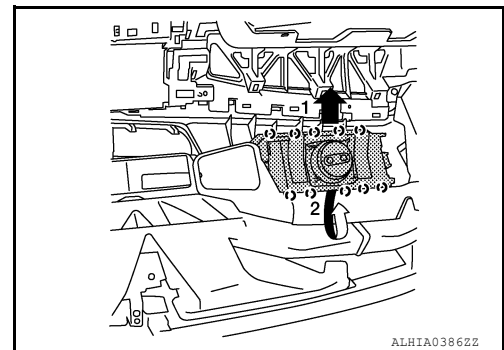

CAUTION:

FRONT PASSENGER AIR BAG MODULE

< REMOVAL AND INSTALLATION >

- Always place the front passenger air bag module with pad side facing upward as shown.

⇐: Upward

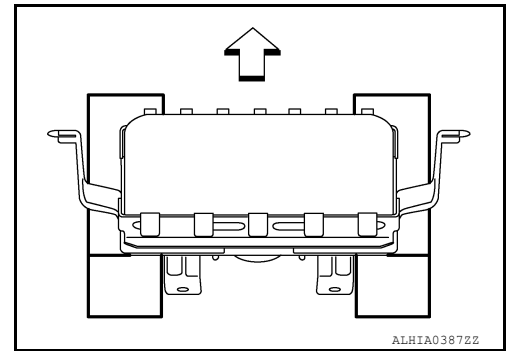

- Replace the front passenger air bag module if it has been dropped or sustained an impact.
- Do not strike the front passenger air bag module.



- Do not insert any foreign objects (screwdriver, etc.) into the passenger air bag module.
- Do not disassemble the passenger air bag module.
- Do not expose the passenger air bag module to temperatures exceeding 90°C (194°F).
- Do not allow oil, grease, detergent, or water to come in contact with the front passenger air bag module.

INSTALLATION

Note the following items, and then install in the reverse order of removal.

CAUTION:

- Do not reuse the front passenger air bag module bolts.
- Do not damage the front passenger air bag module harness during installation.
- After installation is complete, check that no system malfunction is detected causing the air bag warning lamp to illuminate.
- If a malfunction is indicated by the air bag warning lamp after repair or replacement of the malfunctioning parts, perform the SRS final check. Refer to [SRC-16, "Trouble Diagnosis with CONSULT"](#).

SIDE CURTAIN AIR BAG MODULE

< REMOVAL AND INSTALLATION >

SIDE CURTAIN AIR BAG MODULE

Exploded View

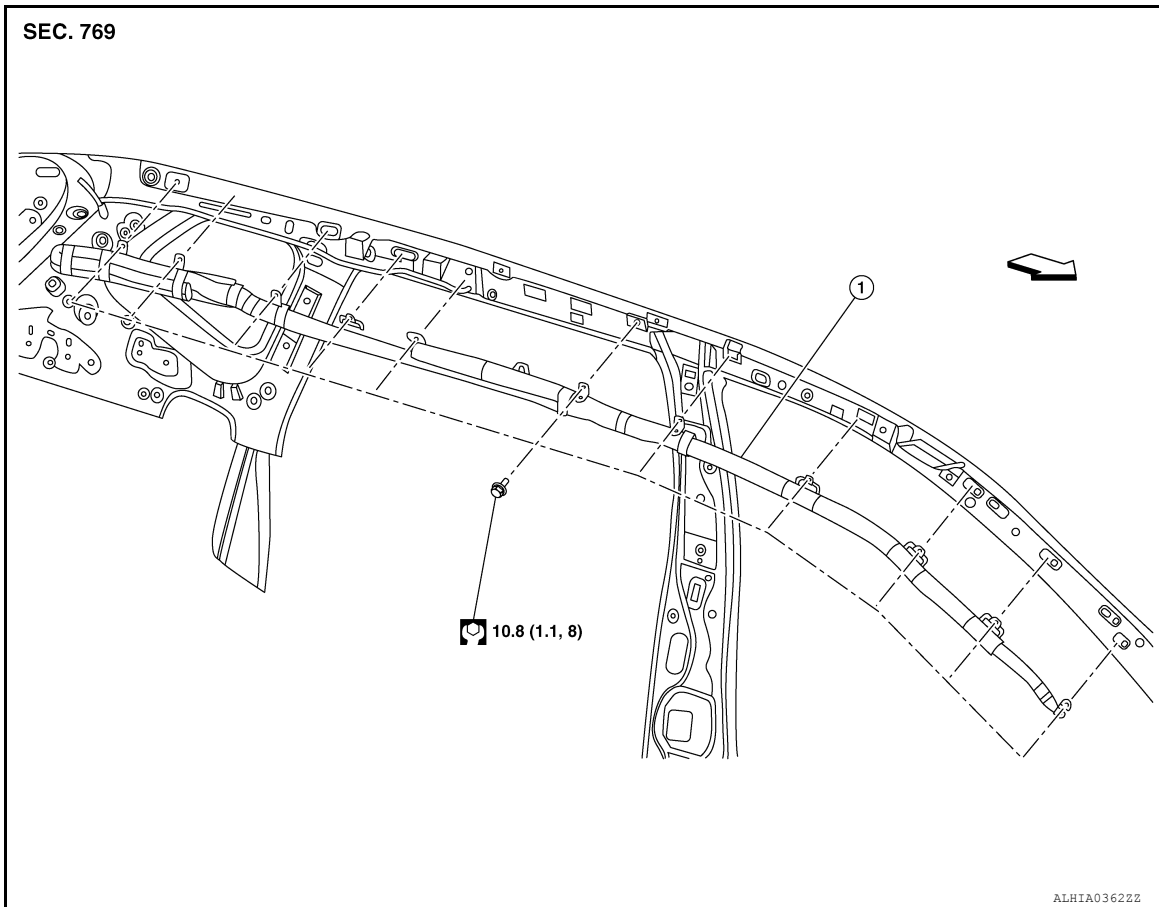

1. Side curtain air bag module ↶ Front

Removal and Installation

INFOID:0000000011279761

WARNING:

- Before servicing the SRS, turn ignition switch OFF, disconnect both battery terminals then wait at least three minutes.
- Always work from the side of air bag module. Do not work in front of it.
- Do not use air tools or electric tools for servicing.

REMOVAL

1. Disconnect negative and positive battery terminals, then wait at least three minutes. Refer to [PG-80, "Removal and Installation"](#).
2. Remove the headlining. Refer to [INT-30, "Removal and Installation"](#).
3. Disconnect the harness connector from the side curtain air bag module.

CAUTION:

- For removing/installing the side curtain air bag module harness connector, insert a thin screwdriver wrapped in tape into the notch, lift the lock and remove the harness connector as shown.
- Install the harness connector with the lock raised, and push the lock into the harness connector as shown.
- After installing the harness connector, check that the lock is pushed in securely.

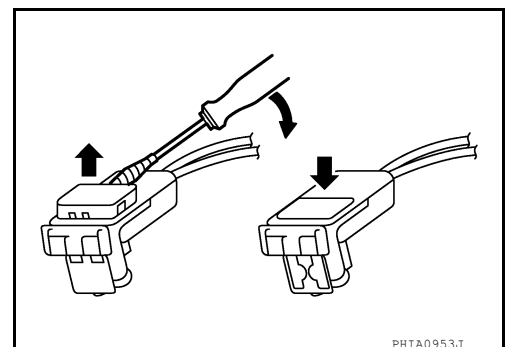

SIDE CURTAIN AIR BAG MODULE

< REMOVAL AND INSTALLATION >

4. Remove bolts, and side curtain air bag module.

CAUTION:

- Replace the side curtain air bag module if it has been dropped or sustained an impact.
- Do not strike the side curtain air bag module.
- Do not insert any foreign objects (screwdriver, etc.) into the side curtain air bag module.
- Do not disassemble the side curtain air bag module.
- Do not expose the side curtain air bag module to temperatures exceeding 90 °C (194 °F).
- Do not allow oil, grease, detergent or water to come in contact with the side curtain air bag module.

INSTALLATION

Note the following items, and then install in the reverse order of removal.

CAUTION:

- Do not damage the harness while installing the side curtain air bag module.
- Make sure that the side curtain air bag module bracket supporting hooks are securely seated into the body slots before releasing the side curtain air bag module during installation to avoid damaging the side curtain air bag module.
- Make sure that the anti-twist stripe (black for RH side, blue for LH side) is visible along entire length of side curtain air bag module.
- If a malfunction is indicated by the air bag warning lamp after repair or replacement of the malfunctioning parts, perform the SRS final check. Refer to [SRC-16, "Trouble Diagnosis with CONSULT"](#).
- After installation is complete, check that no system malfunction is detected causing the air bag warning lamp to illuminate.

FRONT SIDE AIR BAG MODULE

< REMOVAL AND INSTALLATION >

FRONT SIDE AIR BAG MODULE

Removal and Installation

INFOID:000000011279762

The front side air bag module is part of the front seatback. For removal and installation of the front seatback, refer to [SE-56, "Seatback"](#).

A

B

C

D

E

F

G

SR

I

J

K

L

M

N

O

P

CRASH ZONE SENSOR

< REMOVAL AND INSTALLATION >

CRASH ZONE SENSOR

Exploded View

INFOID:000000011279763

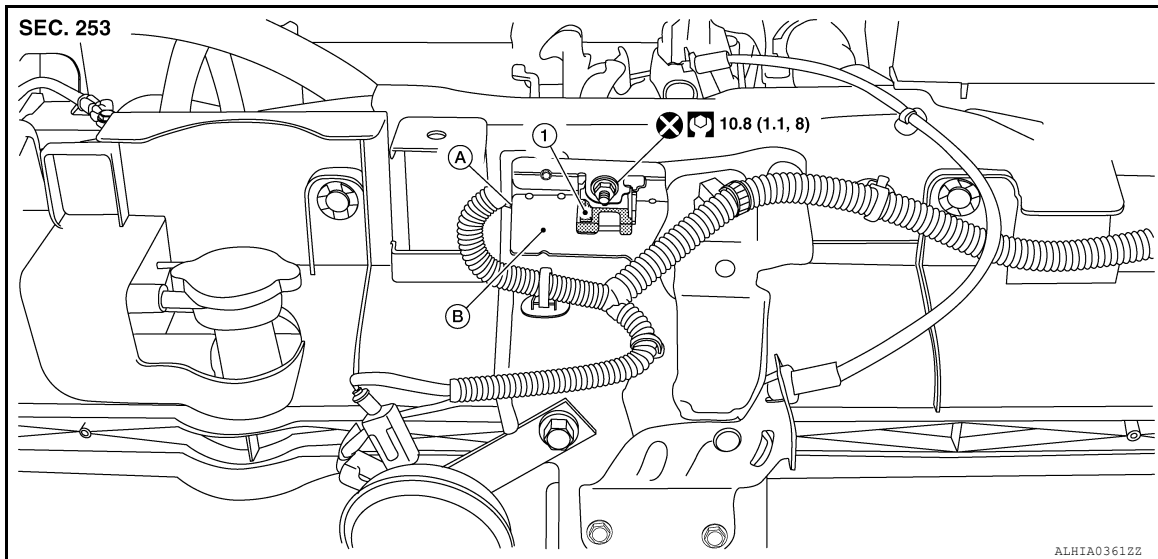

1. Crash zone sensor A. Crash zone sensor harness B. Bracket connector

Removal and Installation

INFOID:000000011279764

WARNING:

- Before servicing the SRS, turn ignition switch OFF, disconnect both battery terminals then wait at least three minutes.
- Do not use air tools or electric tools for servicing.

REMOVAL

1. Disconnect negative and positive battery terminals, then wait at least three minutes. Refer to [PG-80, "Removal and Installation"](#).
2. Remove front grille. Refer to [EXT-23, "Removal and Installation"](#).
3. Remove crash zone sensor nut.

CAUTION:

Do not reuse the crash zone sensor nut.

4. Disconnect crash zone sensor harness connector, and remove crash zone sensor and bracket.

CAUTION:

- Replace the crash zone sensor if it has been dropped or sustained an impact.
- Do not strike the crash zone sensor.
- Replace the crash zone sensor if either the driver air bag or the front passenger air bag has been deployed.

INSTALLATION

Installation is in the reverse order of removal.

CAUTION:

- Do not reuse the crash zone sensor nut.
- Do not damage the harness connector during installation.
- After installation is complete, check that no system malfunction is detected causing the air bag warning lamp to illuminate.
- If a malfunction is indicated by the air bag warning lamp after repair or replacement of the malfunctioning parts, perform the SRS final check. Refer to [SRC-16, "Trouble Diagnosis with CONSULT"](#).

SIDE AIR BAG (SATELLITE) SENSOR

< REMOVAL AND INSTALLATION >

SIDE AIR BAG (SATELLITE) SENSOR

Exploded View

INFOID:000000011279765

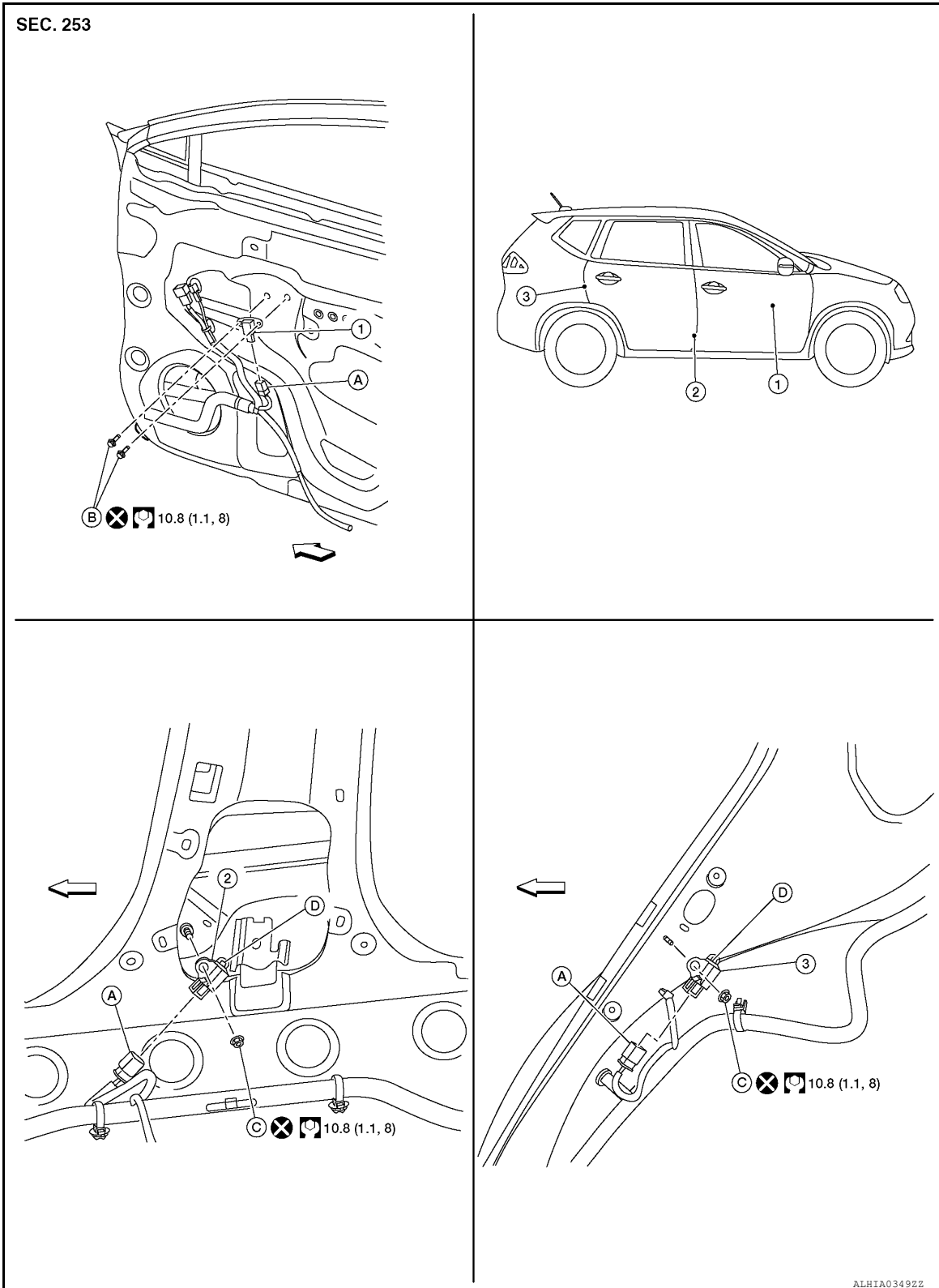

A
B
C
D
E
F
G
SR
I
J
K
L
M
N
O
P

1. Front door satellite sensor 2. Front side air bag satellite sensor 3. Rear side satellite sensor

SIDE AIR BAG (SATELLITE) SENSOR

< REMOVAL AND INSTALLATION >

- | | | |
|---------------------------------------|---------|--------|
| A. Satellite sensor harness connector | B Bolt | C. Nut |
| D. Pawl | ⇐ Front | |

NOTE:

RH side shown, LH side similar.

Removal and Installation

INFOID:000000011279766

WARNING:

- Before servicing the SRS, turn ignition switch OFF, disconnect both battery terminals then wait at least three minutes.
- Do not use air tools or electric tools for servicing.

FRONT SIDE AIR BAG SATELLITE SENSOR

Removal

1. Disconnect negative and positive battery terminals, then wait at least three minutes. Refer to [PG-80, "Removal and Installation"](#).
2. Remove the center pillar lower finisher. Refer to [INT-22, "CENTER PILLAR LOWER FINISHER : Removal and Installation"](#).
3. Place aside the front seat belt retractor.
4. Remove the front side air bag satellite sensor nut.

CAUTION:

Do not reuse the front side air bag satellite sensor nut.

5. Disconnect the harness connector from the front side air bag satellite sensor and remove.

CAUTION:

- Replace the front side air bag satellite sensor if it has been dropped or sustained an impact.
- Do not strike the front side air bag satellite sensor.

Installation

Installation is in the reverse order of removal.

- Position the front side air bag satellite sensor using the pawl before tightening the nut to specification.

CAUTION:

- Do not reuse the front side air bag satellite sensor nut.
- Do not damage the harness connector during installation.
- After installation is complete, check that no system malfunction is detected causing the air bag warning lamp to illuminate.
- If a malfunction is indicated by the air bag warning lamp after repair or replacement of the malfunctioning parts, perform the SRS final check. Refer to [SRC-16, "Trouble Diagnosis with CONSULT"](#).

REAR SIDE AIR BAG SATELLITE SENSOR

Removal

1. Disconnect negative and positive battery terminals, then wait at least three minutes. Refer to [PG-80, "Removal and Installation"](#).
2. Remove the luggage side lower finisher. Refer to [INT-34, "LUGGAGE SIDE LOWER FINISHER : Removal and Installation - With Third Row Seat"](#) (WITH THIRD ROW SEAT), [INT-34, "LUGGAGE SIDE LOWER FINISHER : Removal and Installation - With Third Row Seat"](#) (WITHOUT THIRD ROW SEAT).
3. Remove the rear side air bag satellite sensor bolt.

CAUTION:

Do not reuse the rear side air bag satellite sensor bolt.

4. Disconnect the harness connector from the rear side air bag satellite sensor and remove.

CAUTION:

- Replace the rear side air bag satellite sensor if it has been dropped or sustained an impact.
- Do not strike the rear side air bag satellite sensor.

Installation

Installation is in the reverse order of removal.

- Position the rear side air bag satellite sensor using the pawl before tightening the bolt to specification.

CAUTION:

SIDE AIR BAG (SATELLITE) SENSOR

< REMOVAL AND INSTALLATION >

- Do not reuse the rear side air bag satellite sensor bolt.
- Do not damage the harness connector during installation.
- After installation is complete, check that no system malfunction is detected causing the air bag warning lamp to illuminate.
- If a malfunction is indicated by the air bag warning lamp after repair or replacement of the malfunctioning parts, perform the SRS final check. Refer to [SRC-16, "Trouble Diagnosis with CONSULT"](#).

A
B

FRONT DOOR SATELLITE SENSOR

Removal

1. Disconnect negative and positive battery terminals, then wait at least three minutes. Refer to [PG-80, "Removal and Installation"](#).
2. Remove the front door finisher. Refer to [INT-15, "Removal and Installation"](#).
3. Partially remove front door vapor barrier.
4. Remove the front door satellite sensor bolts.
CAUTION:
Do not reuse the front door satellite sensor bolts.
5. Disconnect the harness connector from the front door satellite sensor and remove.
CAUTION:
 - Replace the front door satellite sensor if it has been dropped or sustained an impact.
 - Do not strike the front door satellite sensor.

C
D
E
F
G

Installation

Installation is in the reverse order of removal.

CAUTION:

- Do not reuse the front door satellite sensor bolts.
- Do not damage the harness connector during installation.
- After installation is complete, check that no system malfunction is detected causing the air bag warning lamp to illuminate.
- If a malfunction is indicated by the air bag warning lamp after repair or replacement of the malfunctioning parts, perform the SRS final check. Refer to [SRC-16, "Trouble Diagnosis with CONSULT"](#).

SR
I
J
K
L
M
N
O
P

AIR BAG DIAGNOSIS SENSOR UNIT

< REMOVAL AND INSTALLATION >

AIR BAG DIAGNOSIS SENSOR UNIT

Exploded View

INFOID:000000011279767

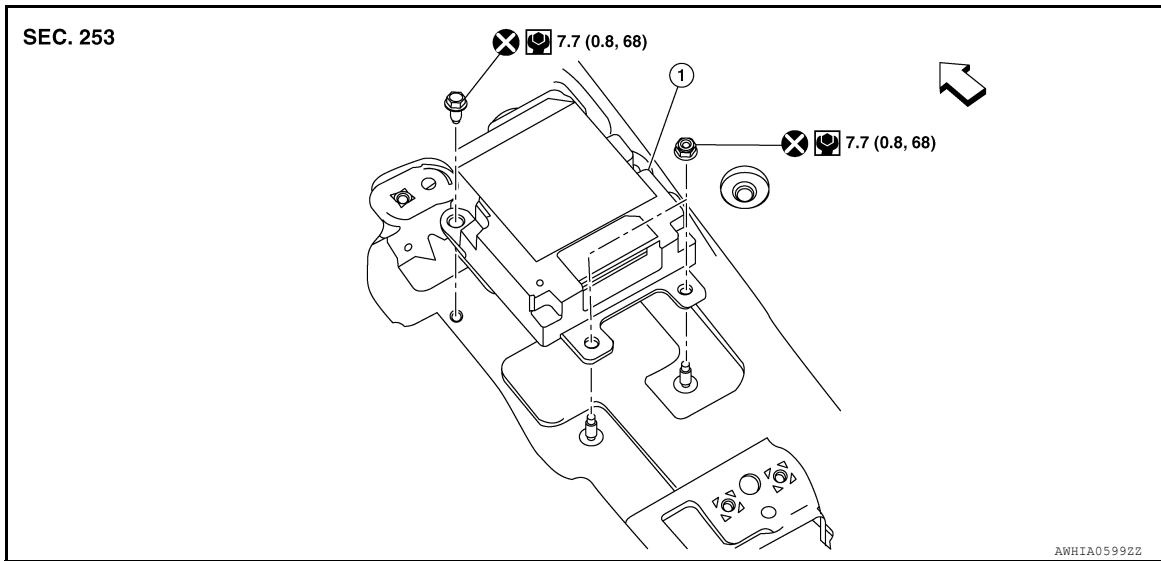

1. Diagnosis sensor unit ← Front

Removal and Installation

INFOID:000000011279768

WARNING:

- Before servicing the SRS, turn ignition switch OFF, disconnect both battery terminals then wait at least three minutes.
- Before disconnecting the air bag diagnosis sensor unit harness connectors, be sure to disconnect each harness connector of the side curtain air bag modules, front seat belt pre-tensioner, and front side air bag module, to prevent accidental air bag deployment by static electricity and seat belt pre-tensioner operation.
- Do not use the air tools or electric tools for servicing.
- When replacing the air bag diagnosis sensor unit, always check with the parts department for the latest parts information. Installing an incorrect air bag diagnosis sensor unit may or may not cause the air bag warning lamp to illuminate and may cause incorrect deployment of the supplemental air bags and seat belt pre-tensioners in a collision resulting in serious personal injury or death.

REMOVAL

1. Always check the air bag diagnosis sensor unit ECU discriminated number (identification number) or part number using CONSULT.
2. Disconnect negative and positive battery terminals, then wait at least three minutes. Refer to [PG-80, "Removal and Installation"](#).
3. Remove center console assembly. Refer to [IP-19, "Removal and Installation"](#).
4. Disconnect the harness connectors for the following SRS components: [SR-19, "Removal and Installation"](#) (side curtain air bag modules), [SR-28, "Removal and Installation"](#) (front seat belt pre-tensioner) and [SR-17, "Removal and Installation"](#) (front side air bag module).
5. Disconnect the harness connectors from the diagnosis sensor unit.
6. Remove bolt and nuts, then remove the air bag diagnosis sensor unit.

CAUTION:

- Do not reuse the air bag diagnosis sensor unit bolt and nuts.
- Replace the air bag diagnosis sensor unit if any SRS air bag has been deployed or if any front seat belt pre-tensioner has been deployed.

AIR BAG DIAGNOSIS SENSOR UNIT

< REMOVAL AND INSTALLATION >

- Replace the air bag diagnosis sensor unit if it has been dropped or sustained an impact.
- Do not strike the air bag diagnosis sensor unit.

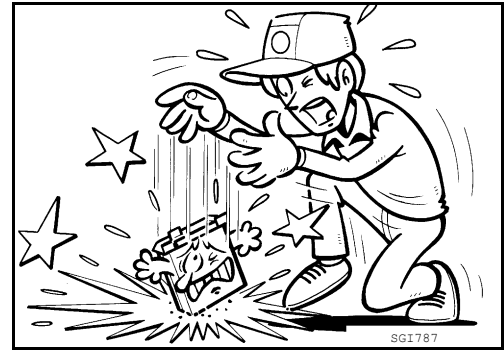

INSTALLATION

Install air bag diagnosis sensor unit in the reverse order of removal.

CAUTION:

- Do not reuse the air bag diagnosis sensor unit bolt and nuts.
- The air bag diagnosis sensor unit must always be installed with the label arrow mark "←" pointing toward the front of the vehicle for proper operation.
- Do not damage the air bag diagnosis sensor unit harness connectors during installation.
- After installation is complete, check that no system malfunction is detected causing the air bag warning lamp to illuminate.
- If a malfunction is indicated by the air bag warning lamp after repair or replacement of the malfunctioning parts, perform the SRS final check. Refer to [SRC-16. "Trouble Diagnosis with CONSULT"](#).
- After replacing the air bag diagnosis sensor unit, confirm using CONSULT that the ECU discriminated number (identification number) or part number of the new replacement air bag diagnosis sensor unit matches the ECU discriminated number (identification number) or part number of the replaced (old) air bag diagnosis sensor unit.

NOTE:

If the ECU discriminated number or part number of the new replacement air bag diagnosis sensor unit differs from the ECU discriminated number or part number of the replaced air bag diagnosis sensor unit, reconfirm the parts information and verify that the correct air bag diagnosis sensor unit was installed.

A
B
C
D
E
F
G
SR
I
J
K
L
M
N
O
P

FRONT SEAT BELT PRE-TENSIONER

< REMOVAL AND INSTALLATION >

FRONT SEAT BELT PRE-TENSIONER

Removal and Installation

INFOID:000000011279769

The front seat belt has two pre-tensioners. One pre-tensioner is part of the seat belt retractor and the other is a lap belt pre-tensioner. For removal and installation refer to [SB-8. "SEAT BELT RETRACTOR : Removal and Installation"](#) (seat belt retractor) and [SB-8. "Exploded View"](#) (lap belt pretensioner).

FRONT SEAT BELT BUCKLE SWITCH

< REMOVAL AND INSTALLATION >

FRONT SEAT BELT BUCKLE SWITCH

Removal and Installation

INFOID:000000011279770

The front seat belt buckle switch is part of the front seat belt buckle. For removal and installation of the front seat belt buckle, refer to [SB-11, "FRONT SEAT BELT BUCKLE : Removal and Installation"](#).

A
B
C
D
E
F
G
SR
I
J
K
L
M
N
O
P

OCCUPANT CLASSIFICATION SYSTEM

< REMOVAL AND INSTALLATION >

OCCUPANT CLASSIFICATION SYSTEM

Removal and Installation

INFOID:000000011279771

OCCUPANT CLASSIFICATION SYSTEM CONTROL UNIT

WARNING:

- Before servicing the SRS, turn ignition switch OFF, disconnect both battery terminals then wait at least three minutes.
- Do not use air tools or electric tools for servicing.

Removal

1. Slide front seat passenger side to full forward position.
2. Disconnect negative and positive battery terminals, then wait at least three minutes. Refer to [PG-80, "Removal and Installation"](#).
3. Remove occupant classification system control unit screws (A).
4. Disconnect the harness connector (B) and remove occupant classification system control unit (1).

CAUTION:

- Replace the occupant classification control unit if it has been dropped or sustained an impact.
- Do not strike the occupant classification control unit.

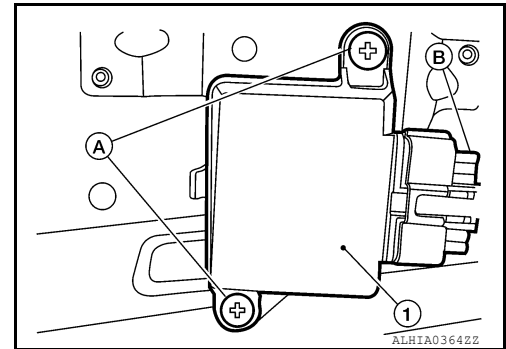

Installation

Installation is in the reverse order of removal.

WARNING:

- Zero point reset must be performed every time the occupant classification system control unit is removed/replaced.

CAUTION:

- Do not damage the harness connector during installation.
- After installation is complete, check that no system malfunction is detected causing the air bag warning lamp to illuminate.
- If a malfunction is indicated by the air bag warning lamp after repair or replacement of the malfunctioning parts, perform the SRS final check. Refer to [SRC-16, "Trouble Diagnosis with CONSULT"](#).

OCCUPANT CLASSIFICATION SYSTEM SENSORS

Removal

1. Remove the front seat passenger side. Refer to [SE-35, "PASSENGER SIDE : Removal and Installation"](#).
2. Remove seat cushion outer finisher (RH).
 - a. For manual seat:
 - i. Remove snap ring (1) as shown (←) using a suitable tool, then remove the recline lever (2).

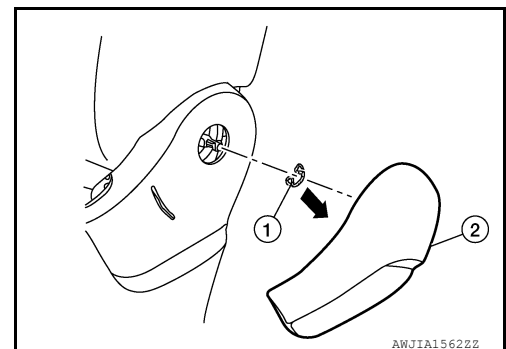

OCCUPANT CLASSIFICATION SYSTEM

< REMOVAL AND INSTALLATION >

- ii. Release clips (A) from seat frame (1) and pawls, then remove seat cushion outer finisher (RH).

- △: Clip
- : Pawl

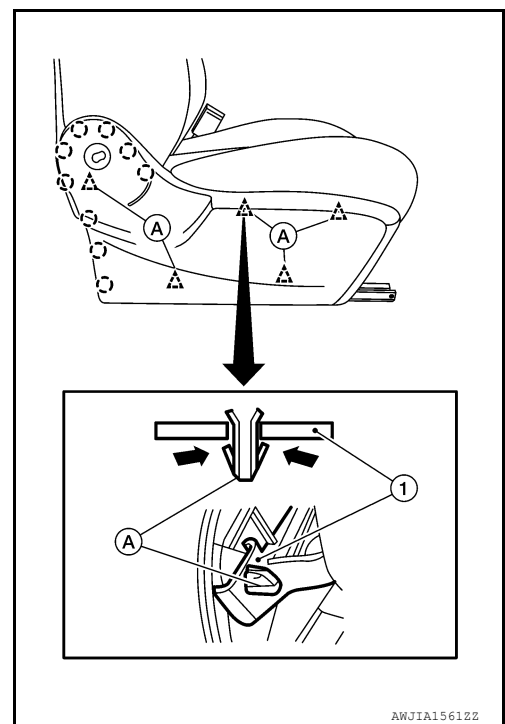

A
B
C
D
E
F
G

- b. For power seat:
 - i. Remove the seat cushion outer finisher (RH).
 - ii. Remove seat slide knob (1) and seat recline knob (2).
 - iii. Release clips (A) from seat frame (3), as shown (←).
 - △: Clip
 - iv. Release pawls and remove.
 - : Pawl

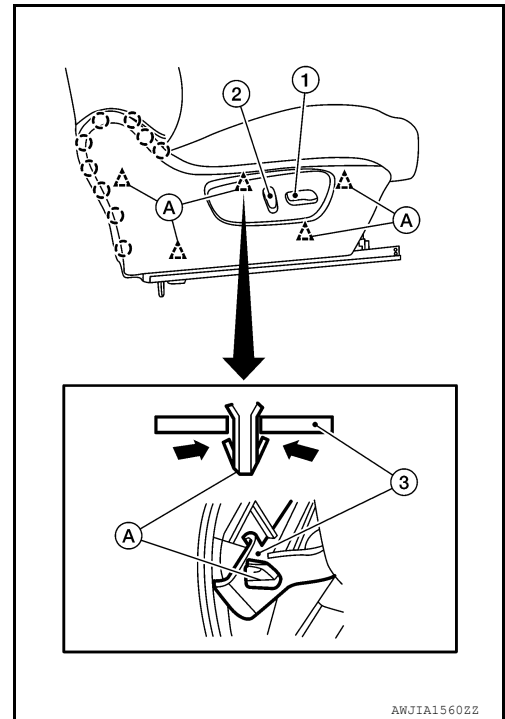

SR

I
J
K
L
M
N
O
P

- v. Disconnect harness connector from power seat switch.

OCCUPANT CLASSIFICATION SYSTEM

< REMOVAL AND INSTALLATION >

3. Release pawls and clips, and remove seat cushion outer finisher (LH) in the direction shown (←).

- : Pawl
- : Metal clip
- △: Clip

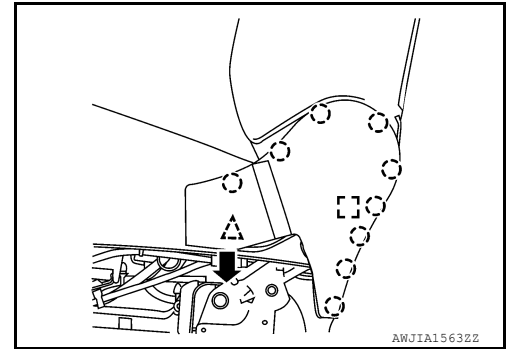

4. Remove screw (A), then release pawl and remove seat cushion rear finisher (LH/RH) (1).

- : Pawl

NOTE:

Seatback trim repositioned for clarity.

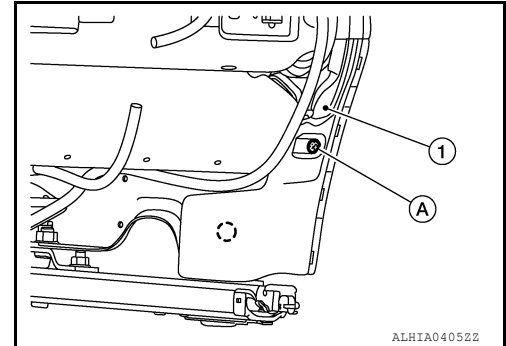

5. Disconnect harness connectors from occupant classification system sensors.

6. Remove nuts (A) and seat track (LH/RH).

CAUTION:

Do not reuse nuts. Replace with new nuts during installation.

NOTE:

RH shown; LH similar.

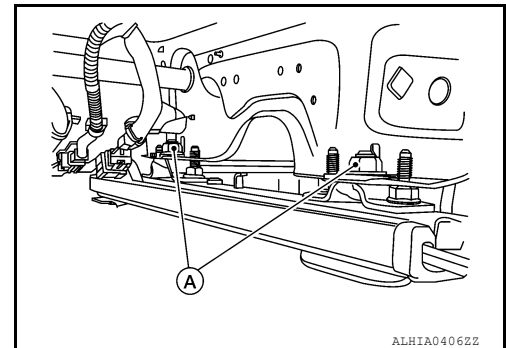

7. Remove nuts (A) and occupant classification system sensors (1).

CAUTION:

Do not reuse nuts. Replace with new nuts during installation.

↔: Front

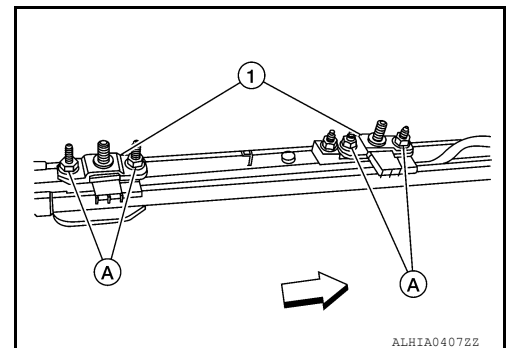

Installation

Installation is in the reverse order of removal.

CAUTION:

- Do not reuse nuts. Replace with new part during installation.
- Tighten the nuts to specification.

Seat track nuts	45 N·m (4.6 kg-m, 33 ft-lb)
Occupant classification system sensor nuts	22 N·m (2.2 kg-m, 16 ft-lb)

FRONT PASSENGER AIR BAG OFF INDICATOR

< REMOVAL AND INSTALLATION >

FRONT PASSENGER AIR BAG OFF INDICATOR

Removal and Installation

INFOID:000000011406075

REMOVAL

1. Remove A/C switch assembly. Refer to [HAC-102. "Removal and Installation"](#).
2. Remove screws and the front passenger air bag off indicator from cluster lid C.

INSTALLATION

Installation is in the reverse order of removal.

A

B

C

D

E

F

G

SR

I

J

K

L

M

N

O

P