

SECTION **DEF**
 DEFOGGER

A
B
C
D
E
F
G
H
I
J
K
DEF
M
N
O
P

CONTENTS

PRECAUTION	3	REAR DEFOGGER : CONSULT Function (BCM - REAR DEFOGGER)	11
PRECAUTIONS	3	ECU DIAGNOSIS INFORMATION	13
Precaution for Supplemental Restraint System (SRS) "AIR BAG" and "SEAT BELT PRE-TENSIONER"	3	BCM (BODY CONTROL MODULE)	13
Handling for Adhesive and Primer	3	List of ECU Reference	13
Precaution for Work	3	WIRING DIAGRAM	14
PREPARATION	5	REAR WINDOW DEFOGGER SYSTEM	14
PREPARATION	5	Wiring Diagram	14
Special Service Tools	5	BASIC INSPECTION	20
SYSTEM DESCRIPTION	6	DIAGNOSIS AND REPAIR WORKFLOW	20
COMPONENT PARTS	6	Work Flow	20
Component Parts Location	6	DTC/CIRCUIT DIAGNOSIS	23
Rear window defogger	7	REAR WINDOW DEFOGGER SWITCH	23
Door mirror defogger	7	WITH MANUAL A/C	23
SYSTEM	8	WITH MANUAL A/C : Description	23
System Description	8	WITH MANUAL A/C : Component Function Check	23
DIAGNOSIS SYSTEM (BCM) (WITH INTELLIGENT KEY SYSTEM)	9	WITH MANUAL A/C : Diagnosis Procedure	23
COMMON ITEM	9	WITH AUTO A/C	23
COMMON ITEM : CONSULT Function (BCM - COMMON ITEM)	9	WITH AUTO A/C : Description	23
REAR DEFOGGER	9	WITH AUTO A/C : Component Function Check	23
REAR DEFOGGER : CONSULT Function (BCM - REAR DEFOGGER)	10	WITH AUTO A/C : Diagnosis Procedure	23
DIAGNOSIS SYSTEM (BCM) (WITHOUT INTELLIGENT KEY SYSTEM)	11	REAR WINDOW DEFOGGER RELAY	25
COMMON ITEM	11	Description	25
COMMON ITEM : CONSULT Function (BCM - COMMON ITEM)	11	Component Function Check	25
REAR DEFOGGER	11	Diagnosis Procedure	25
		Component Inspection	26
		REAR WINDOW DEFOGGER POWER SUPPLY AND GROUND CIRCUIT	27
		Description	27
		Component Function Check	27

Diagnosis Procedure	27	Diagnosis Procedure	35
Component Inspection	28		
DOOR MIRROR DEFOGGER LH	29	BOTH DOORS MIRROR DEFOGGER DON'T OPERATE BUT REAR WINDOW DEFOGGER OPERATES	36
Description	29	Diagnosis Procedure	36
Component Function Check	29		
Diagnosis Procedure	29	DRIVER SIDE DOOR MIRROR DEFOGGER DOES NOT OPERATE.	37
Component Inspection	30	Diagnosis Procedure	37
DOOR MIRROR DEFOGGER RH	31		
Description	31	PASSENGER SIDE DOOR MIRROR DEFOGGER DOES NOT OPERATE.	38
Component Function Check	31	Diagnosis Procedure	38
Diagnosis Procedure	31		
Component Inspection	32	REAR WINDOW DEFOGGER SWITCH DOES NOT LIGHT, BUT REAR WINDOW DEFOGGER OPERATES	39
SYMPTOM DIAGNOSIS	33	Diagnosis Procedure	39
DEFOGGER SYSTEM SYMPTOMS	33		
Symptom Table	33	REMOVAL AND INSTALLATION	40
REAR WINDOW DEFOGGER AND DOOR MIRROR DEFOGGER DO NOT OPERATE.	34	FILAMENT	40
Diagnosis Procedure	34	Inspection and Repair	40
REAR WINDOW DEFOGGER DOES NOT OPERATE BUT BOTH OF DOOR MIRROR DEFOGGER OPERATE.	35	CONDENSER	42
		Removal and Installation	42

PRECAUTIONS

< PRECAUTION >

PRECAUTION

PRECAUTIONS

Precaution for Supplemental Restraint System (SRS) "AIR BAG" and "SEAT BELT PRE-TENSIONER"

INFOID:000000012423317

The Supplemental Restraint System such as "AIR BAG" and "SEAT BELT PRE-TENSIONER", used along with a front seat belt, helps to reduce the risk or severity of injury to the driver and front passenger for certain types of collision. Information necessary to service the system safely is included in the SR and SB section of this Service Manual.

WARNING:

- To avoid rendering the SRS inoperative, which could increase the risk of personal injury or death in the event of a collision which would result in air bag inflation, all maintenance must be performed by an authorized NISSAN/INFINITI dealer.
- Improper maintenance, including incorrect removal and installation of the SRS, can lead to personal injury caused by unintentional activation of the system. For removal of Spiral Cable and Air Bag Module, see the SR section.
- Do not use electrical test equipment on any circuit related to the SRS unless instructed to in this Service Manual. SRS wiring harnesses can be identified by yellow and/or orange harnesses or harness connectors.

PRECAUTIONS WHEN USING POWER TOOLS (AIR OR ELECTRIC) AND HAMMERS

WARNING:

- When working near the Airbag Diagnosis Sensor Unit or other Airbag System sensors with the Ignition ON or engine running, DO NOT use air or electric power tools or strike near the sensor(s) with a hammer. Heavy vibration could activate the sensor(s) and deploy the air bag(s), possibly causing serious injury.
- When using air or electric power tools or hammers, always switch the Ignition OFF, disconnect the battery and wait at least three minutes before performing any service.

Handling for Adhesive and Primer

INFOID:000000012423318

- Do not use an adhesive which is past its usable date. Shelf life of this product is limited to six months after the date of manufacture. Carefully adhere to the expiration or manufacture date printed on the box.
- Keep primers and adhesive in a cool, dry place. Ideally, they should be stored in a refrigerator.
- Open the seal of the primer and adhesive just before application. Discard the remainder.
- Before application, be sure to shake the primer container to stir the contents. If any floating material is found, do not use it.
- If any primer or adhesive contacts the skin, wipe it off with gasoline or equivalent and wash the skin with soap.
- When using primer and adhesive, always observe the precautions in the instruction manual.

Precaution for Work

INFOID:000000012423319

- When removing or disassembling each component, be careful not to damage or deform it. If a component may be subject to interference, be sure to protect it with a shop cloth.
- When removing (disengaging) components with a screwdriver or similar tool, be sure to wrap the component with a shop cloth or vinyl tape to protect it.
- Protect the removed parts with a shop cloth and prevent them from being dropped.
- Replace a deformed or damaged clip.
- If a part is specified as a non-reusable part, always replace it with a new one.
- Be sure to tighten bolts and nuts securely to the specified torque.
- After installation is complete, be sure to check that each part works properly.
- Follow the steps below to clean components:
 - Water soluble dirt:
 - Dip a soft cloth into lukewarm water, wring the water out of the cloth and wipe the dirty area.
 - Then rub with a soft, dry cloth.
 - Oily dirt:
 - Dip a soft cloth into lukewarm water with mild detergent (concentration: within 2 to 3%) and wipe the dirty area.

A

B

C

D

E

F

G

H

I

J

K

DEF

M

N

O

P

PRECAUTIONS

< PRECAUTION >

- Then dip a cloth into fresh water, wring the water out of the cloth and wipe the detergent off.
- Then rub with a soft, dry cloth.
- Do not use organic solvent such as thinner, benzene, alcohol or gasoline.
- For genuine leather seats, use a genuine leather seat cleaner.

PREPARATION

< PREPARATION >

PREPARATION

PREPARATION

Special Service Tools

INFOID:0000000012423320

The actual shape of the tools may differ from those illustrated here.

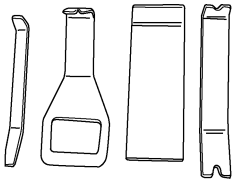
Tool number (TechMate No.) Tool name	Description
<p>— (J-46534) Trim Tool Set</p>  <p>AWJIA0483ZZ</p>	Removing trim components

A
B
C
D
E
F
G
H
I
J
K
DEF
M
N
O
P

COMPONENT PARTS

< SYSTEM DESCRIPTION >

SYSTEM DESCRIPTION

COMPONENT PARTS

Component Parts Location

INFOID:000000012423321

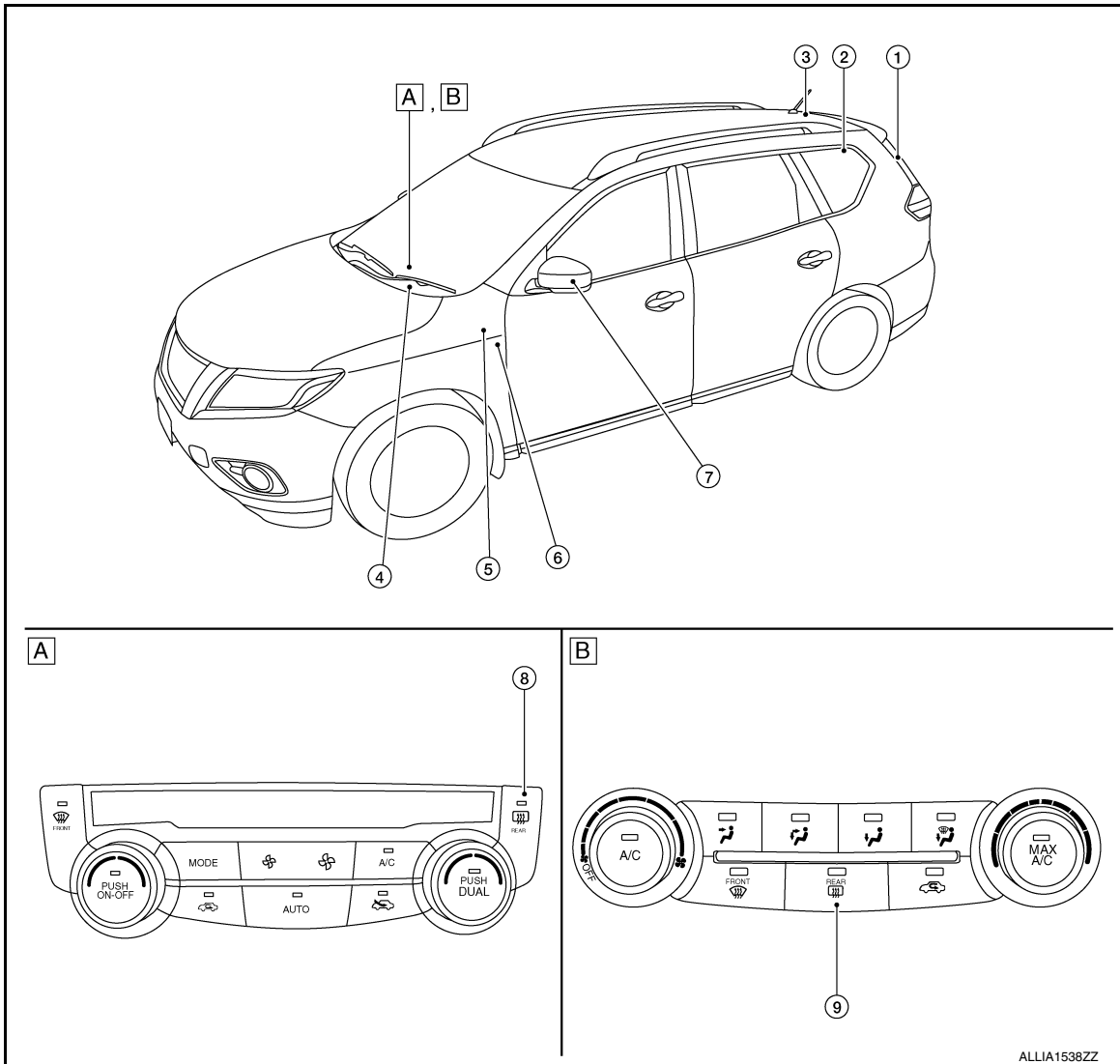

A. A/C switch (auto A/C)

B. Front air control (manual A/C)

No.	Component	Description
1.	Rear window defogger connector	Refer to DEF-7, "Rear window defogger" .
2.	(Rear window defogger)	
3.	Rear window defogger condenser	Removes the noise that is generated when rear window defogger turns ON/OFF.
4.	A/C auto amp. ¹	<ul style="list-style-type: none"> Displays the rear window defogger ON to the display when detecting the operation of the rear window defogger.
5.	BCM	<ul style="list-style-type: none"> Operates the rear window defogger with the operation of rear window defogger switch. Performs the timer control of rear window defogger.
6.	Rear window defogger relay	<ul style="list-style-type: none"> Operates the rear window defogger and the door mirror defogger with the control signal from BCM.

COMPONENT PARTS

< SYSTEM DESCRIPTION >

No.	Component	Description
7.	Door mirror LH ³ (RH similar)	Refer to DEF-7, "Door mirror defogger" .
8.	A/C switch ¹ (rear window defogger switch)	<ul style="list-style-type: none"> The rear window defogger switch is turned ON. Turns the indicator lamp ON when detecting the operation of rear window defogger.
9.	Front air control ² (rear window defogger switch)	<ul style="list-style-type: none"> The rear window defogger switch is turned ON. Turns the indicator lamp ON when detecting the operation of rear window defogger.

1: With auto A/C

2: With manual A/C

3: With heated mirrors

Rear window defogger

INFOID:000000012423322

Heats the heating wire with the power supply from the rear window defogger relay to prevent the rear window from fogging up.

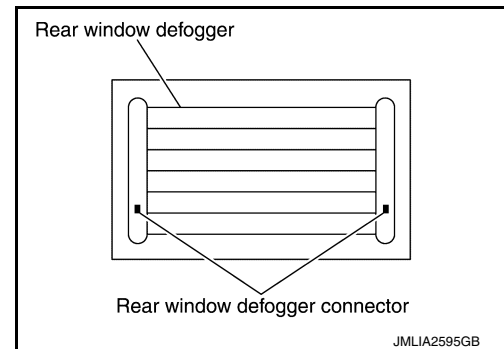

Door mirror defogger

INFOID:000000012423323

Heats the heating wire with the power supply from the rear window defogger relay to prevent the door mirror from fogging up.

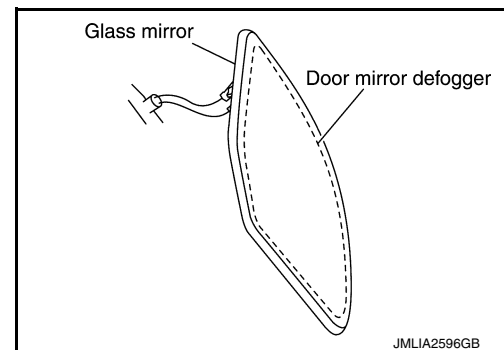

A
B
C
D
E
F
G
H
I
J
K
DEF
M
N
O
P

SYSTEM

< SYSTEM DESCRIPTION >

SYSTEM

System Description

INFOID:000000012423324

SYSTEM DIAGRAM

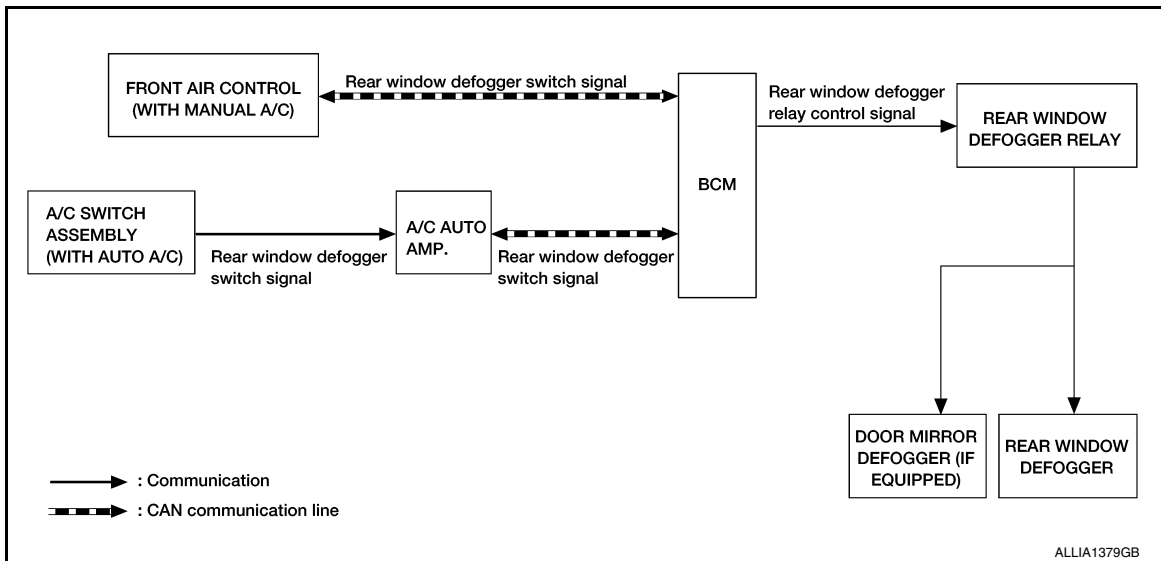

OPERATION DESCRIPTION

- When rear window defogger switch is turned ON while ignition switch is ON, the rear window defogger switch transmits rear window defogger switch signal to BCM.
- BCM turns rear window defogger relay ON when rear window defogger switch signal is received.
- Rear window defogger and door mirror defogger (with door mirror defogger) are supplied with power and operate when rear window defogger relay turns ON.
- Rear window defogger ON is displayed when front air control (manual A/C) or A/C switch (auto A/C) receives signals.

TIMER FUNCTION

- BCM turns rear window defogger relay ON for approximately 15 minutes when rear window defogger switch is turned ON while ignition switch is ON. It makes rear window defogger and door mirror defogger (with door mirror defogger) operate.
- Timer is canceled after pressing rear window defogger switch again during timer operation. Then BCM turns rear window defogger relay OFF. The same reaction also occurs during timer operation, if the ignition switch is turned OFF.

INPUT/OUTPUT SIGNAL CHART

Switch	Input signal to BCM	BCM function	Actuator
Rear window defogger switch	Defogger switch signal	Rear window defogger and door mirror defogger control	Rear window defogger Door mirror defogger *

*: If equipped

DIAGNOSIS SYSTEM (BCM) (WITH INTELLIGENT KEY SYSTEM)

< SYSTEM DESCRIPTION >

DIAGNOSIS SYSTEM (BCM) (WITH INTELLIGENT KEY SYSTEM) COMMON ITEM

COMMON ITEM : CONSULT Function (BCM - COMMON ITEM)

INFOID:000000012564815

APPLICATION ITEM

CONSULT performs the following functions via CAN communication with BCM.

Direct Diagnostic Mode	Description
Ecu Identification	The BCM part number is displayed.
Self Diagnostic Result	The BCM self diagnostic results are displayed.
Data Monitor	The BCM input/output data is displayed in real time.
Active Test	The BCM activates outputs to test components.
Work support	The settings for BCM functions can be changed.
Configuration	<ul style="list-style-type: none"> The vehicle specification can be read and saved. The vehicle specification can be written when replacing BCM.
CAN Diag Support Mntr	The result of transmit/receive diagnosis of CAN communication is displayed.

SYSTEM APPLICATION

BCM can perform the following functions.

System	Sub System	Direct Diagnostic Mode						
		Ecu Identification	Self Diagnostic Result	Data Monitor	Active Test	Work support	Configuration	CAN Diag Support Mntr
Door lock	DOOR LOCK		×	×	×	×		
Rear window defogger	REAR DEFOGGER			×	×	×		
Warning chime	BUZZER			×	×			
Interior room lamp timer	INT LAMP			×	×	×		
Exterior lamp	HEADLAMP			×	×	×		
Wiper and washer	WIPER			×	×	×		
Turn signal and hazard warning lamps	FLASHER			×	×			
Intelligent Key system	INTELLIGENT KEY		×	×	×	×		
Combination switch	COMB SW			×				
BCM	BCM	×	×			×	×	×
Immobilizer	IMMU		×	×	×			
Interior room lamp battery saver	BATTERY SAVER			×	×			
Back door open	TRUNK			×				
Vehicle security system	THEFT ALM			×	×	×		
RAP system	RETAINED PWR			×				
Signal buffer system	SIGNAL BUFFER			×				
Air conditioner	AIR CONDITIONER				×			

REAR DEFOGGER

DIAGNOSIS SYSTEM (BCM) (WITH INTELLIGENT KEY SYSTEM)

< SYSTEM DESCRIPTION >

REAR DEFOGGER : CONSULT Function (BCM - REAR DEFOGGER)

INFOID:000000012564816

DATA MONITOR

Monitor Item [Unit]	Description
PUSH SW [On/Off]	Indicates condition of push-button ignition switch.
REAR DEF SW [On/Off]	Indicates condition of rear window defogger switch.

ACTIVE TEST

Test Item	Description
REAR DEFOGGER	This test is able to check rear window defogger operation [Off/On].

WORK SUPPORT

Support Item	Setting	Description
SET R-DEF TIMER	MODE3	Rear defogger turns OFF after 1 minute.
	MODE2	Rear defogger remains ON until turned OFF.
	MODE1*	Rear defogger turns OFF after 15 minutes.

* : Initial setting

DIAGNOSIS SYSTEM (BCM) (WITHOUT INTELLIGENT KEY SYSTEM)

< SYSTEM DESCRIPTION >

DIAGNOSIS SYSTEM (BCM) (WITHOUT INTELLIGENT KEY SYSTEM) COMMON ITEM

COMMON ITEM : CONSULT Function (BCM - COMMON ITEM)

INFOID:0000000012564817

APPLICATION ITEM

CONSULT performs the following functions via CAN communication with BCM.

Direct Diagnostic Mode	Description
Ecu Identification	The BCM part number is displayed.
Self Diagnostic Result	The BCM self diagnostic results are displayed.
Data Monitor	The BCM input/output data is displayed in real time.
Active Test	The BCM activates outputs to test components.
Work support	The settings for BCM functions can be changed.
Configuration	<ul style="list-style-type: none"> The vehicle specification can be read and saved. The vehicle specification can be written when replacing BCM.
CAN Diag Support Mntr	The result of transmit/receive diagnosis of CAN communication is displayed.

SYSTEM APPLICATION

BCM can perform the following functions.

System	Sub System	Direct Diagnostic Mode						
		Ecu Identification	Self Diagnostic Result	Data Monitor	Active Test	Work support	Configuration	CAN Diag Support Mntr
Door lock	DOOR LOCK			x	x	x		
Rear window defogger	REAR DEFOGGER			x	x	x		
Warning chime	BUZZER			x	x			
Interior room lamp timer	INT LAMP			x	x	x		
Remote keyless entry system	MULTI REMOTE ENT					x		
Exterior lamp	HEADLAMP			x	x			
Wiper and washer	WIPER			x	x	x		
Turn signal and hazard warning lamps	FLASHER			x	x			
Combination switch	COMB SW			x				
BCM	BCM	x	x			x	x	x
Immobilizer	IMMU		x		x			
Interior room lamp battery saver	BATTERY SAVER			x	x			
Back door open	TRUNK			x				
Vehicle security system	THEFT ALM			x	x	x		
RAP system	RETAINED PWR			x				
TPMS	AIR PRESSURE MONITOR		x	x	x	x		

REAR DEFOGGER

REAR DEFOGGER : CONSULT Function (BCM - REAR DEFOGGER)

INFOID:0000000012564818

DATA MONITOR

DIAGNOSIS SYSTEM (BCM) (WITHOUT INTELLIGENT KEY SYSTEM)

< SYSTEM DESCRIPTION >

Monitor Item [Unit]	Description
REAR DEF SW [On/Off]	Indicates condition of rear window defogger switch.

ACTIVE TEST

Test Item	Description
REAR DEFOGGER	This test is able to check rear window defogger operation [Off/On].

WORK SUPPORT

Support Item	Setting	Description
SET R-DEF TIMER	MODE3	Rear defogger turns OFF after 1 minute.
	MODE2	Rear defogger remains ON until turned OFF.
	MODE1*	Rear defogger turns OFF after 15 minutes.

* : Initial setting

BCM (BODY CONTROL MODULE)

< ECU DIAGNOSIS INFORMATION >

ECU DIAGNOSIS INFORMATION

BCM (BODY CONTROL MODULE)

List of ECU Reference

INFOID:0000000012423329

ECU	Reference
BCM (with Intelligent Key system)	BCS-29, "Reference Value"
	BCS-47, "Fail Safe"
	BCS-47, "DTC Inspection Priority Chart"
	BCS-48, "DTC Index"
BCM (without Intelligent Key system)	BCS-97, "Reference Value"
	BCS-108, "Fail Safe"
	BCS-109, "DTC Inspection Priority Chart"
	BCS-109, "DTC Index"

A
B
C
D
E
F
G
H
I
J
K
DEF
M
N
O
P

REAR WINDOW DEFOGGER SYSTEM

< WIRING DIAGRAM >

WIRING DIAGRAM

REAR WINDOW DEFOGGER SYSTEM

Wiring Diagram

INFOID:000000012423330

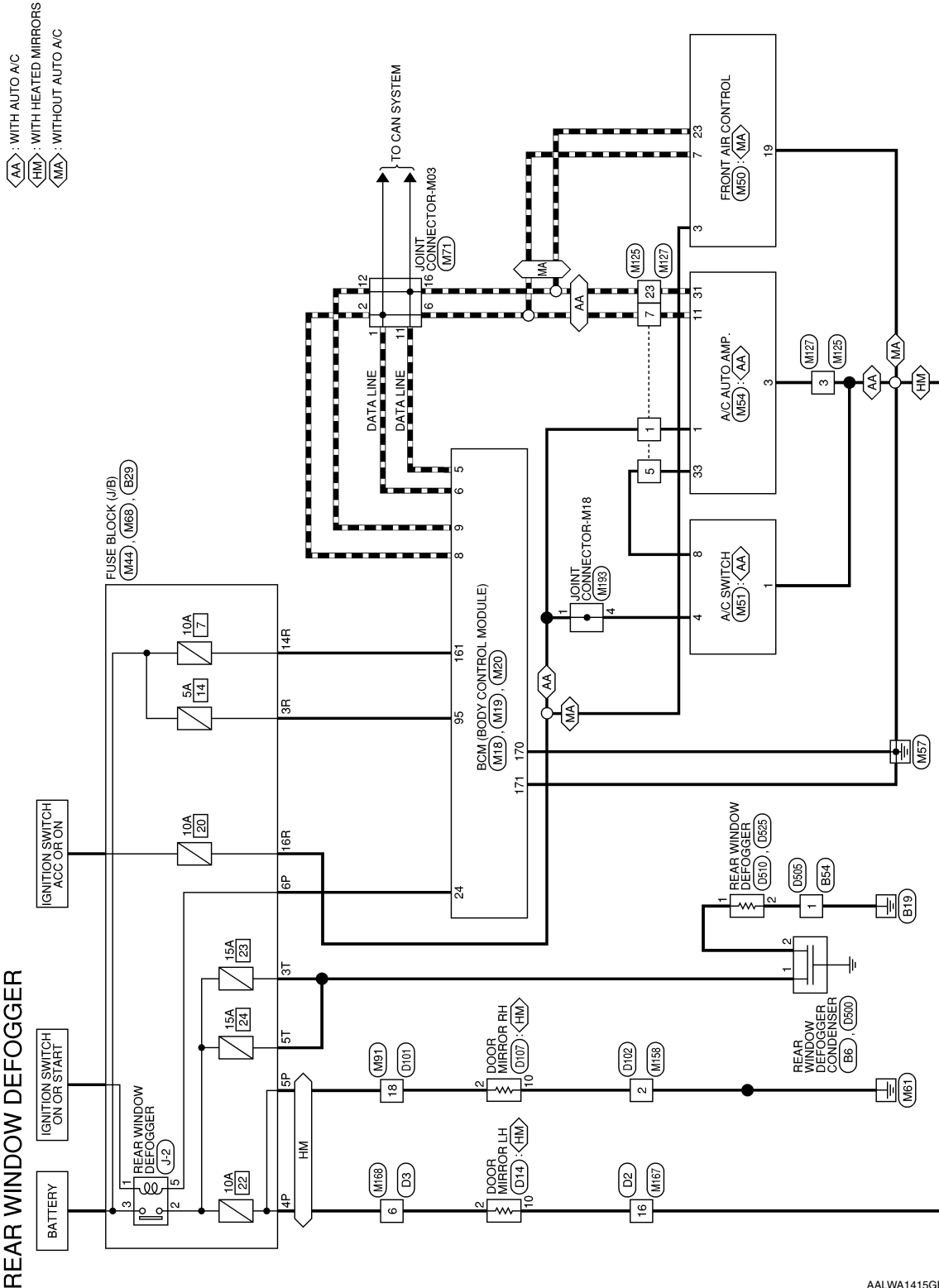

AALWA1415GB

REAR WINDOW DEFOGGER SYSTEM

< WIRING DIAGRAM >

REAR WINDOW DEFOGGER CONNECTORS

Connector No.	M18
Connector Name	BCM (BODY CONTROL MODULE)
Connector Color	GRAY

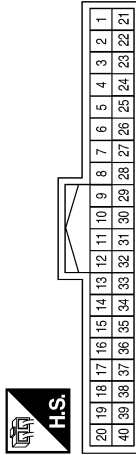

Terminal No.	Color of Wire	Signal Name
5	R	CAN-L
6	L	CAN-H
8	L	CAN-H
9	R	CAN-L
24	LA/R	O DEFROSTER RLD

Connector No.	M19
Connector Name	BCM (BODY CONTROL MODULE)
Connector Color	BLACK

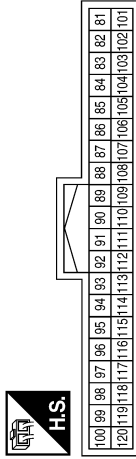

Terminal No.	Color of Wire	Signal Name
95	V	I SHORTING PIN

Connector No.	M20
Connector Name	BCM (BODY CONTROL MODULE)
Connector Color	BROWN



Terminal No.	Color of Wire	Signal Name
161	W	I PWR ECU
170	B	I GND1
171	B	I GND2

Connector No.	M44
Connector Name	FUSE BLOCK (J/B)
Connector Color	WHITE

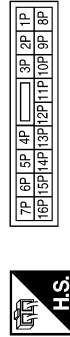

Terminal No.	Color of Wire	Signal Name
4P	LG	-
5P	GR	-
6P	LA/R	-

Connector No.	M50
Connector Name	FRONT AIR CONTROL
Connector Color	WHITE

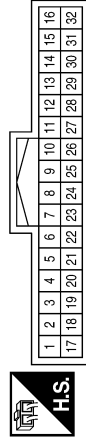

Terminal No.	Color of Wire	Signal Name
3	SB	IGN TEMPO
7	L	CAN-H
19	B	GND
23	R	CAN-L

Connector No.	M51
Connector Name	A/C SWITCH
Connector Color	BLACK

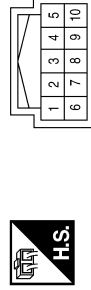

Terminal No.	Color of Wire	Signal Name
1	B	-
4	GR	-
8	LG	-

AALIA2107GB

A
B
C
D
E
F
G
H
I
J
K
DEF
M
N
O
P

REAR WINDOW DEFOGGER SYSTEM

< WIRING DIAGRAM >

Connector No.	M54
Connector Name	A/C AUTO AMP.
Connector Color	BLACK



1	2	3	4	5	6	7	8	9	10	11	12	13	14	15	16	17	18	19	20
21	22	23	24	25	26	27	28	29	30	31	32	33	34	35	36	37	38	39	40

Terminal No.	Color of Wire	Signal Name
1	BG	AUTO ACC
3	R	GND
11	L	CAN-H
31	W	CAN-L
33	Y	LIN SW AMP

Connector No.	M68
Connector Name	FUSE BLOCK (J/B)
Connector Color	BROWN



7A	6A	5A	4A	3A	2A	1A		
16R	15R	14R	13R	12R	11R	10R	9R	8R

Terminal No.	Color of Wire	Signal Name
3R	V	-
14R	W	-
16R	GR	-

Connector No.	M71
Connector Name	JOINT CONNECTOR-M03
Connector Color	BLUE



9	8	7	6	5	4	3	2	1		
20	19	18	17	16	15	14	13	12	11	10

Terminal No.	Color of Wire	Signal Name
1	L	-
2	L	-
6	L	-
11	R	-
12	R	-
16	R	-

Connector No.	M91
Connector Name	WIRE TO WIRE
Connector Color	WHITE



1	2	3	4	5	6	7	8	9	10	11	12
13	14	15	16	17	18	19	20	21	22	23	24

Terminal No.	Color of Wire	Signal Name
18	GR	-

Connector No.	M125
Connector Name	WIRE TO WIRE
Connector Color	WHITE



1	2	3	4	5	6	7	8	9	10	11	12	13	14	15	16
17	18	19	20	21	22	23	24	25	26	27	28	29	30	31	32

Terminal No.	Color of Wire	Signal Name
1	SB	-
3	B	-
5	LG	-
7	L	-
23	R	-

Connector No.	M127
Connector Name	WIRE TO WIRE
Connector Color	WHITE



16	15	14	13	12	11	10	9	8	7	6	5	4	3	2	1
32	31	30	29	28	27	26	25	24	23	22	21	20	19	18	17

Terminal No.	Color of Wire	Signal Name
1	BG	-
3	R	-
5	Y	-
7	L	-
23	W	-

REAR WINDOW DEFOGGER SYSTEM

< WIRING DIAGRAM >

Connector No.	M168
Connector Name	WIRE TO WIRE
Connector Color	WHITE

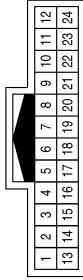

Terminal No.	6	Color of Wire	LG	Signal Name	-
--------------	---	---------------	----	-------------	---

Connector No.	M167
Connector Name	WIRE TO WIRE
Connector Color	WHITE

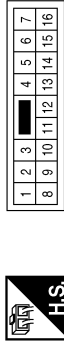

Terminal No.	16	Color of Wire	B	Signal Name	-
--------------	----	---------------	---	-------------	---

Connector No.	M158
Connector Name	WIRE TO WIRE
Connector Color	WHITE

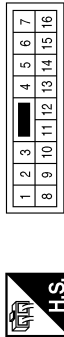

Terminal No.	2	Color of Wire	GR	Signal Name	-
--------------	---	---------------	----	-------------	---

Connector No.	B29
Connector Name	FUSE BLOCK (J/B)
Connector Color	WHITE



Terminal No.	3T	Color of Wire	G	Signal Name	-
	5T	Color of Wire	G	Signal Name	-

Connector No.	B6
Connector Name	REAR WINDOW DEFOGGER CONDENSER
Connector Color	BLACK



Terminal No.	1	Color of Wire	G	Signal Name	-
--------------	---	---------------	---	-------------	---

Connector No.	M193
Connector Name	JOINT CONNECTOR-M18
Connector Color	WHITE

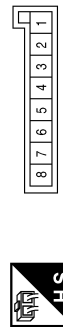

Terminal No.	1	Color of Wire	GR	Signal Name	-
	4	Color of Wire	GR	Signal Name	-

AALIA2948GB

A
B
C
D
E
F
G
H
I
J
K
DEF
M
N
O
P

REAR WINDOW DEFOGGER SYSTEM

< WIRING DIAGRAM >

Connector No.	D3
Connector Name	WIRE TO WIRE
Connector Color	WHITE

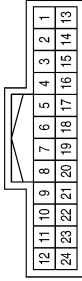

Terminal No.	6	Color of Wire	LG	Signal Name	-
--------------	---	---------------	----	-------------	---

Connector No.	D2
Connector Name	WIRE TO WIRE
Connector Color	WHITE

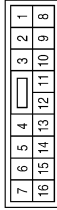

Terminal No.	16	Color of Wire	B	Signal Name	-
--------------	----	---------------	---	-------------	---

Connector No.	B54
Connector Name	WIRE TO WIRE
Connector Color	WHITE



Terminal No.	1	Color of Wire	B	Signal Name	-
--------------	---	---------------	---	-------------	---

Connector No.	D102
Connector Name	WIRE TO WIRE
Connector Color	WHITE

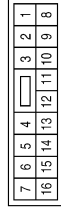

Terminal No.	2	Color of Wire	LA/G	Signal Name	-
--------------	---	---------------	------	-------------	---

Connector No.	D101
Connector Name	WIRE TO WIRE
Connector Color	WHITE

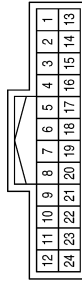

Terminal No.	18	Color of Wire	GR	Signal Name	-
--------------	----	---------------	----	-------------	---

Connector No.	D14
Connector Name	DOOR MIRROR LH
Connector Color	WHITE



Terminal No.	2	Color of Wire	LG	Signal Name	-
	10	Color of Wire	B	Signal Name	-

AALIA2110GB

REAR WINDOW DEFOGGER SYSTEM

< WIRING DIAGRAM >

Connector No.	D505
Connector Name	WIRE TO WIRE
Connector Color	WHITE



Terminal No.	Color of Wire	Signal Name
1	B	-

Connector No.	D500
Connector Name	REAR WINDOW DEFOGGER CONDENSER
Connector Color	BLACK



Terminal No.	Color of Wire	Signal Name
2	G	-

Connector No.	D107
Connector Name	DOOR MIRROR RH
Connector Color	WHITE



Terminal No.	Color of Wire	Signal Name
2	GR	-
10	LA/G	-

Connector No.	D525
Connector Name	REAR WINDOW DEFOGGER
Connector Color	BLACK



Terminal No.	Color of Wire	Signal Name
2	B	-

Connector No.	D510
Connector Name	REAR WINDOW DEFOGGER
Connector Color	BLACK



Terminal No.	Color of Wire	Signal Name
1	G	-

AALIA2111GB

A
B
C
D
E
F
G
H
I
J
K
DEF
M
N
O
P

DIAGNOSIS AND REPAIR WORKFLOW

< BASIC INSPECTION >

BASIC INSPECTION

DIAGNOSIS AND REPAIR WORKFLOW

Work Flow

INFOID:0000000012423331

OVERALL SEQUENCE

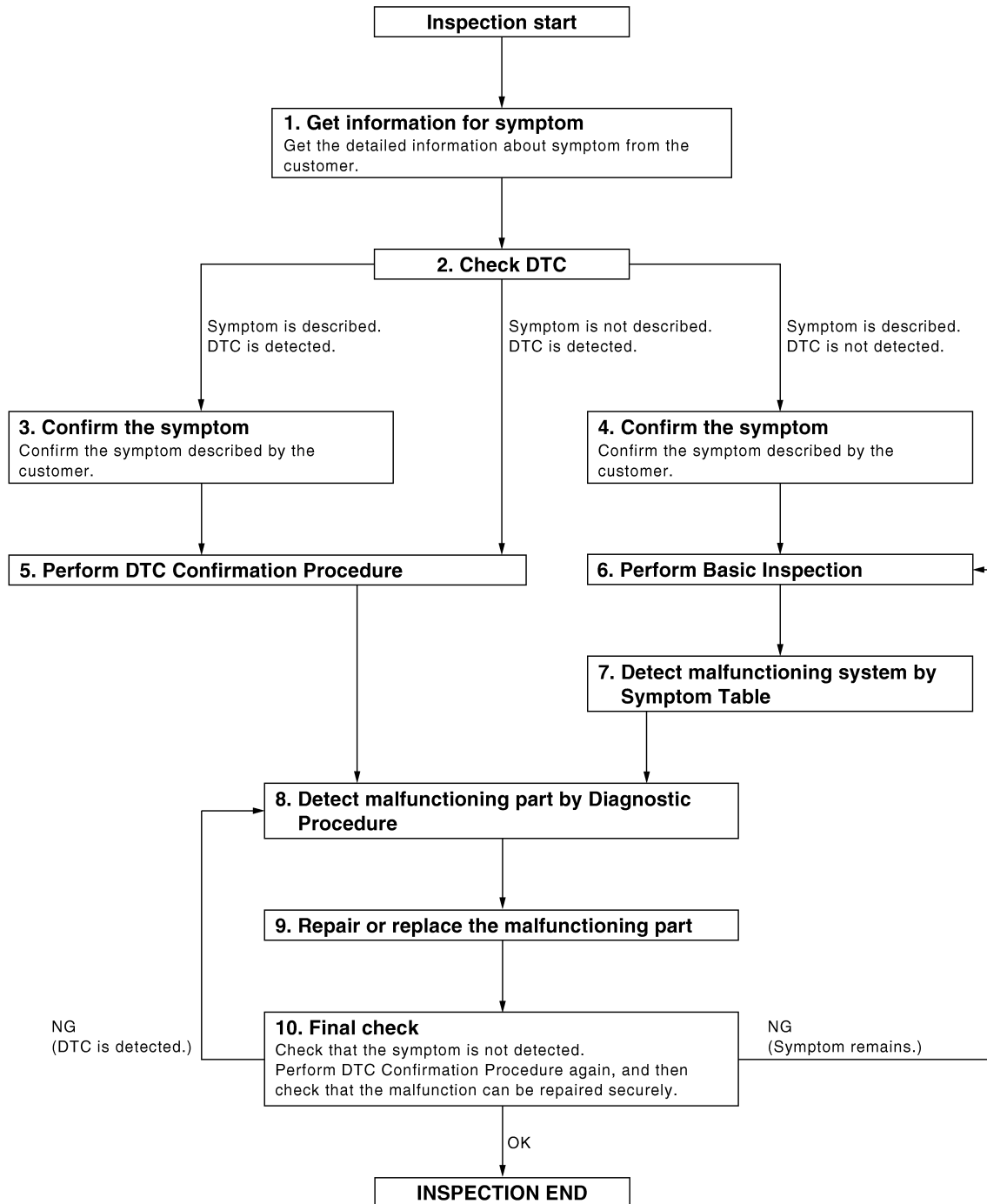

DETAILED FLOW

Revision: September 2015

DEF-20

JMKIA0101GB

2016 Rogue NAM

DIAGNOSIS AND REPAIR WORKFLOW

< BASIC INSPECTION >

1. GET INFORMATION FOR SYMPTOM

Get the detailed information from the customer about the symptom (the condition and the environment when the incident/malfunction occurred).

>> GO TO 2.

2. CHECK DTC

1. Check DTC.
2. Perform the following procedure if DTC is displayed.
 - Record DTC and freeze frame data (Print them out with CONSULT.)
 - Erase DTC.
 - Study the relationship between the cause detected by DTC and the symptom described by the customer.
3. Check related service bulletins for information.

Is any symptom described and any DTC detected?

- Symptom is described, DTC is displayed>>GO TO 3.
- Symptom is described, DTC is not displayed>>GO TO 4.
- Symptom is not described, DTC is displayed>>GO TO 5.

3. CONFIRM THE SYMPTOM

Confirm the symptom described by the customer.
Connect CONSULT to the vehicle in "Data Monitor" mode and check real time diagnosis results.
Verify relation between the symptom and the condition when the symptom is detected.

>> GO TO 5.

4. CONFIRM THE SYMPTOM

Confirm the symptom described by the customer.
Connect CONSULT to the vehicle in "Data Monitor" mode and check real time diagnosis results.
Verify relation between the symptom and the condition when the symptom is detected.

>> GO TO 6.

5. PERFORM DTC CONFIRMATION PROCEDURE

Perform DTC Confirmation Procedure for the displayed DTC, and then check that DTC is detected again.
At this time, always connect CONSULT to the vehicle, and check diagnostic results in real time.
If two or more DTCs are detected, refer to [BCS-47, "DTC Inspection Priority Chart"](#) (with Intelligent Key system) or [BCS-109, "DTC Inspection Priority Chart"](#) (without Intelligent Key system) and determine trouble diagnosis order.

NOTE:

- Freeze frame data is useful if the DTC is not detected.
- Perform Component Function Check if DTC Confirmation Procedure is not included in Service Manual. This simplified check procedure is an effective alternative though DTC cannot be detected during this check.
If the result of Component Function Check is NG, it is the same as the detection of DTC by DTC Confirmation Procedure.

Is DTC detected?

- YES >> GO TO 8.
- NO >> Refer to [GI-45, "Intermittent Incident"](#).

6. PERFORM BASIC INSPECTION

Perform [DEF-20, "Work Flow"](#).

>> GO TO 7.

7. DETECT MALFUNCTIONING SYSTEM BY SYMPTOM TABLE

Detect malfunctioning system according to [DEF-8, "System Description"](#) based on the confirmed symptom in step 4, and determine the trouble diagnosis order based on possible causes and symptom.

A
B
C
D
E
F
G
H
I
J
K
DEF
M
N
O
P

DIAGNOSIS AND REPAIR WORKFLOW

< BASIC INSPECTION >

>> GO TO 8.

8. DETECT MALFUNCTIONING PART BY DIAGNOSTIC PROCEDURE

Inspect according to Diagnostic Procedure of the system.

NOTE:

The Diagnostic Procedure described based on open circuit inspection. A short circuit inspection is also required for the circuit check in the Diagnostic Procedure.

Is malfunctioning part detected?

YES >> GO TO 9.

NO >> Check voltage of related BCM terminals using CONSULT.

9. REPAIR OR REPLACE THE MALFUNCTIONING PART

1. Repair or replace the malfunctioning part.
2. Reconnect parts or connectors disconnected during Diagnostic Procedure again after repair and replacement.
3. Check DTC. If DTC is displayed, erase it.

>> GO TO 10.

10. FINAL CHECK

When DTC was detected in step 2, perform DTC Confirmation Procedure or Component Function Check again, and then check that the malfunction have been repaired securely.

When symptom was described from the customer, refer to confirmed symptom in step 3 or 4, and check that the symptom is not detected.

Does the symptom reappear?

YES (DTC is detected)>>GO TO 8.

YES (Symptom remains)>>GO TO 6.

NO >> Inspection End.

REAR WINDOW DEFOGGER SWITCH

< DTC/CIRCUIT DIAGNOSIS >

DTC/CIRCUIT DIAGNOSIS

REAR WINDOW DEFOGGER SWITCH WITH MANUAL A/C

WITH MANUAL A/C : Description

INFOID:000000012423332

- The rear window defogger is operated by pressing the rear window defogger switch ON.
- The indicator lamp in the rear window defogger switch illuminates while the rear window defogger is ON.

WITH MANUAL A/C : Component Function Check

INFOID:000000012423333

1. CHECK REAR WINDOW DEFOGGER SWITCH FUNCTION

Check that the indicator lamp of the rear window defogger switch illuminates when rear window defogger switch is ON.

Is the inspection result normal?

- YES >> Inspection End.
- NO >> Refer to [DEF-23, "WITH MANUAL A/C : Diagnosis Procedure"](#).

WITH MANUAL A/C : Diagnosis Procedure

INFOID:000000012423334

Regarding Wiring Diagram information, refer to [DEF-14, "Wiring Diagram"](#).

1. CHECK REAR WINDOW DEFOGGER SWITCH OPERATION

 With CONSULT

1. Select "REAR DEFOGGER" of "BCM".
2. Select "REAR DEF SW" in "Data Monitor" mode.
3. Check "REAR DEF SW" indication under the following conditions.

Monitor item	Condition	Status
REAR DEF SW	Rear window defogger switch Pressed	On
	Not Pressed	Off

Is the inspection result normal?

- YES >> Inspection End.
- NO >> Replace front air control. Refer to [HAC-190, "Removal and Installation"](#).

WITH AUTO A/C

WITH AUTO A/C : Description

INFOID:000000012423335

- The rear window defogger is operated by pressing the rear window defogger switch ON.
- The indicator lamp in the rear window defogger switch illuminates while the rear window defogger is ON.

WITH AUTO A/C : Component Function Check

INFOID:000000012423336

1. CHECK REAR WINDOW DEFOGGER SWITCH FUNCTION

Check that the indicator lamp of the rear window defogger switch illuminates when rear window defogger switch is ON.

Is the inspection result normal?

- YES >> Inspection End.
- NO >> Refer to [DEF-23, "WITH MANUAL A/C : Diagnosis Procedure"](#).

WITH AUTO A/C : Diagnosis Procedure

INFOID:000000012423337

A
B
C
D
E
F
G
H
I
J
K
DEF
M
N
O
P

REAR WINDOW DEFOGGER SWITCH

< DTC/CIRCUIT DIAGNOSIS >

Regarding Wiring Diagram information, refer to [DEF-14. "Wiring Diagram"](#).

1. CHECK REAR WINDOW DEFOGGER SWITCH OPERATION

Ⓟ With CONSULT

1. Select "REAR DEFOGGER" of "BCM".
2. Select "REAR DEF SW" in "Data Monitor" mode.
3. Check "REAR DEF SW" indication under the following conditions.

Monitor item	Condition		Status
REAR DEF SW	Rear window defogger switch	Pressed	On
		Not Pressed	Off

Is the inspection result normal?

YES >> Inspection End.

NO >> Replace A/C switch. Refer to [HAC-106. "Removal and Installation"](#).

REAR WINDOW DEFOGGER RELAY

< DTC/CIRCUIT DIAGNOSIS >

REAR WINDOW DEFOGGER RELAY

Description

INFOID:0000000012423338

Power is supplied to the rear window defogger with BCM control.

Component Function Check

INFOID:0000000012423339

1. CHECK REAR WINDOW DEFOGGER RELAY POWER SUPPLY CIRCUIT

Check that an operation noise of rear window defogger relay [located in fuse block (J/B)] can be heard when turning the rear window defogger switch ON.

Is the inspection result normal?

- YES >> Rear window defogger relay power supply circuit is OK.
- NO >> Refer to [DEF-25, "Diagnosis Procedure"](#).

Diagnosis Procedure

INFOID:0000000012423340

Regarding Wiring Diagram information, refer to [DEF-14, "Wiring Diagram"](#).

1. CHECK REAR WINDOW DEFOGGER RELAY GROUND CIRCUIT

1. Turn ignition switch ON.
2. Check voltage between BCM connector and ground.

(+)		(-)	Condition	Voltage (V) (Approx.)	
BCM					
Connector	Terminal				
M18	24	Ground	Rear window defogger switch	ON	0
				OFF	Battery voltage

Is the inspection result normal?

- YES >> Rear window defogger power supply circuit is OK.
- NO >> GO TO 2.

2. CHECK HARNESS CONTINUITY

1. Turn ignition switch OFF.
2. Disconnect BCM and fuse block (J/B).
3. Check continuity between BCM connector and fuse block (J/B) connector.

BCM		Fuse block (J/B)		Continuity
Connector	Terminal	Connector	Terminal	
M18	24	M44	6P	Yes

Is the inspection result normal?

- YES >> GO TO 3.
- NO >> Repair or replace harness.

3. CHECK REAR WINDOW DEFOGGER RELAY

Check rear window defogger relay.
Refer to [DEF-26, "Component Inspection"](#).

Is the inspection result normal?

- YES >> Check intermittent incident. Refer to [GI-45, "Intermittent Incident"](#).
- NO >> Replace rear window defogger relay.

A
B
C
D
E
F
G
H
I
J
K
DEF
M
N
O
P

REAR WINDOW DEFOGGER RELAY

< DTC/CIRCUIT DIAGNOSIS >

Component Inspection

INFOID:000000012423341

1. CHECK REAR WINDOW DEFOGGER RELAY

Check rear window defogger relay.

Terminal		Condition	Continuity
Rear window defogger relay			
3	5	12V direct current supply between terminals 1 and 2.	Yes
		No current supply	No

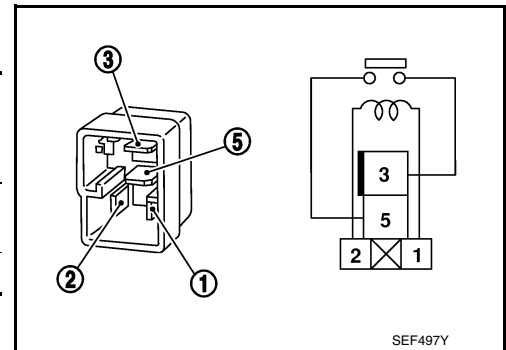

Is the inspection result normal?

YES >> Inspection End.

NO >> Replace rear window defogger relay.

REAR WINDOW DEFOGGER POWER SUPPLY AND GROUND CIRCUIT

< DTC/CIRCUIT DIAGNOSIS >

REAR WINDOW DEFOGGER POWER SUPPLY AND GROUND CIRCUIT

Description

INFOID:000000012423342

Heats the heating wire with the power supply from the rear window defogger relay to prevent the rear window from fogging up.

Component Function Check

INFOID:000000012423343

1. CHECK REAR WINDOW DEFOGGER

Check that the heating wire of rear window defogger is heated when turning the rear window defogger switch ON.

Is the inspection result normal?

- YES >> Rear window defogger is OK.
- NO >> Refer to [DEF-27. "Diagnosis Procedure"](#).

Diagnosis Procedure

INFOID:000000012423344

Regarding Wiring Diagram information, refer to [DEF-14. "Wiring Diagram"](#).

1. CHECK FUSES

Check if any of the following fuses are blown.

Location	Capacity	Fuse No.
Fuse block (J/B)	15A	23
	15A	24

Is the inspection result normal?

- YES >> GO TO 2.
- NO >> Replace the blown fuse after repairing the affected circuit.

2. CHECK REAR WINDOW DEFOGGER POWER SUPPLY CIRCUIT

1. Turn ignition switch ON.
2. Check voltage between fuse block (J/B) connector and ground.

(+)		(-)	Condition	Voltage (V) (Approx.)
Connector	Terminal			
B29	3T, 5T	Ground	Rear window defogger switch	Battery voltage
			ON	
			OFF	0

Is the inspection result normal?

- YES >> GO TO 3.
- NO >> Perform rear window defogger relay diagnosis. Refer to [DEF-25. "Diagnosis Procedure"](#).

3. CHECK POWER SUPPLY CIRCUIT

1. Turn ignition switch ON.
2. Check voltage between rear window defogger connector and ground.

REAR WINDOW DEFOGGER POWER SUPPLY AND GROUND CIRCUIT

< DTC/CIRCUIT DIAGNOSIS >

(+)		(-)	Condition	Voltage (V) (Approx.)	
Rear window defogger					
Connector	Terminal				
D510	1	Ground	Rear window defogger switch	ON	Battery voltage
				OFF	0

Is the inspection result normal?

YES >> GO TO 4.

NO >> GO TO 5.

4. CHECK GROUND CIRCUIT

1. Turn ignition switch OFF.
2. Disconnect rear window defogger.
3. Check continuity between rear window defogger connector and ground.

Rear window defogger		Ground	Continuity
Connector	Terminal		
D525	2		Yes

Is the inspection result normal?

YES >> GO TO 6.

NO >> Repair or replace harness.

5. CHECK HARNESS CONTINUITY

1. Turn ignition switch OFF.
2. Disconnect fuse block (J/B).
3. Check continuity between fuse block (J/B) connector and rear window defogger condenser connector.

Fuse block (J/B)		Rear window defogger condenser		Continuity
Connector	Terminal	Connector	Terminal	
B29	3T	B6	1	Yes
	5T			

Is the inspection result normal?

YES >> Replace rear window defogger condenser. Refer to [DEF-42, "Removal and Installation"](#).

NO >> Replace or repair harness.

6. CHECK FILAMENT

Check filament.

Refer to [DEF-28, "Component Inspection"](#).

Is the inspection result normal?

YES >> Refer to [GI-45, "Intermittent Incident"](#).

NO >> Repair filament. Refer to [DEF-40, "Inspection and Repair"](#).

Component Inspection

INFOID:0000000012423345

1. CHECK FILAMENT

Check the filament for damage or open circuits.

Refer to [DEF-40, "Inspection and Repair"](#).

Is the inspection result normal?

YES >> Inspection End.

NO >> Repair filament. Refer to [DEF-40, "Inspection and Repair"](#).

DOOR MIRROR DEFOGGER LH

< DTC/CIRCUIT DIAGNOSIS >

DOOR MIRROR DEFOGGER LH

Description

INFOID:000000012423346

Heats the heating wire with the power supply from the rear window defogger relay to prevent the door mirror from fogging up.

Component Function Check

INFOID:000000012423347

1. CHECK DOOR MIRROR DEFOGGER LH

Check that heating wire of door mirror defogger LH is heated when turning the rear window defogger switch ON.

Is the inspection result normal?

- YES >> Door mirror defogger is OK.
- NO >> Refer to [DEF-29, "Diagnosis Procedure"](#).

Diagnosis Procedure

INFOID:000000012423348

Regarding Wiring Diagram information, refer to [DEF-14, "Wiring Diagram"](#).

1. CHECK POWER SUPPLY CIRCUIT

1. Turn ignition switch OFF.
2. Disconnect door mirror LH.
3. Turn ignition switch ON.
4. Check voltage between door mirror LH connector and ground.

(+)		(-)	Condition		Voltage (V) (Approx.)
Door mirror LH					
Connector	Terminal				
D14	2	Ground	Rear window defogger switch	ON	Battery voltage
				OFF	0

Is the inspection result normal?

- YES >> GO TO 2.
- NO >> Repair or replace harness.

2. CHECK GROUND CIRCUIT

1. Turn ignition switch OFF.
2. Check continuity between door mirror LH connector and ground.

Door mirror LH		Ground	Continuity
Connector	Terminal		
D14	10		Yes

Is the inspection result normal?

- YES >> GO TO 3.
- NO >> Repair or replace harness.

3. CHECK DOOR MIRROR DEFOGGER LH

Check door mirror defogger LH.
Refer to [DEF-30, "Component Inspection"](#).

Is the inspection result normal?

- YES >> GO TO 4.
- NO >> Replace door mirror LH. Refer to [MIR-22, "Removal and Installation"](#).

A
B
C
D
E
F
G
H
I
J
K
DEF
M
N
O
P

DOOR MIRROR DEFOGGER LH

< DTC/CIRCUIT DIAGNOSIS >

4. CHECK INTERMITTENT INCIDENT

Check intermittent incident.

Refer to [GI-45, "Intermittent Incident"](#).

Is the inspection result normal?

- YES >> Check the following:
- Battery power supply circuit.
 - Fuse block (J/B).
- NO >> Repair or replace the malfunctioning parts.

Component Inspection

INFOID:000000012423349

1. CHECK DOOR MIRROR DEFOGGER LH

1. Turn ignition switch OFF.
2. Disconnect door mirror LH.
3. Check continuity between door mirror terminals.

Terminal		Continuity
2	10	Yes

Is the inspection result normal?

- YES >> Inspection End.
- NO >> Replace door mirror LH. Refer to [MIR-22, "Removal and Installation"](#).

DOOR MIRROR DEFOGGER RH

< DTC/CIRCUIT DIAGNOSIS >

DOOR MIRROR DEFOGGER RH

Description

INFOID:000000012423350

Heats the heating wire with the power supply from the rear window defogger relay to prevent the door mirror from fogging up.

Component Function Check

INFOID:000000012423351

1. CHECK DOOR MIRROR DEFOGGER RH

Check that the heating wire of door mirror defogger RH is heated when turning the rear window defogger switch ON.

Is the inspection result normal?

- YES >> Door mirror defogger RH is OK.
- NO >> Refer to [DEF-31, "Diagnosis Procedure"](#).

Diagnosis Procedure

INFOID:000000012423352

Regarding Wiring Diagram information, refer to [DEF-14, "Wiring Diagram"](#).

1. CHECK POWER SUPPLY CIRCUIT

1. Turn ignition switch OFF.
2. Disconnect door mirror RH.
3. Turn ignition switch ON.
4. Check voltage between door mirror RH connector and ground.

(+)		(-)	Condition		Voltage (V) (Approx.)
Door mirror RH					
Connector	Terminal				
D107	2	Ground	Rear window defogger switch	ON	Battery voltage
				OFF	0

Is the inspection result normal?

- YES >> GO TO 2.
- NO >> Repair or replace harness.

2. CHECK GROUND CIRCUIT

1. Turn ignition switch OFF.
2. Check continuity between door mirror RH connector and ground.

Door mirror RH		Ground	Continuity
Connector	Terminal		
D107	10		Yes

Is the inspection result normal?

- YES >> GO TO 3.
- NO >> Repair or replace harness.

3. CHECK PASSENGER SIDE DOOR MIRROR DEFOGGER

Check door mirror defogger RH.
Refer to [DEF-32, "Component Inspection"](#).

Is the inspection result normal?

- YES >> GO TO 4.
- NO >> Replace door mirror RH. Refer to [MIR-22, "Removal and Installation"](#).

A
B
C
D
E
F
G
H
I
J
K
DEF
M
N
O
P

DOOR MIRROR DEFOGGER RH

< DTC/CIRCUIT DIAGNOSIS >

4. CHECK INTERMITTENT INCIDENT

Check intermittent incident.

Refer to [GI-45, "Intermittent Incident"](#).

Is the inspection result normal?

- YES >> Check the following:
- Battery power supply circuit.
 - Fuse block (J/B).
- NO >> Repair or replace the malfunctioning parts.

Component Inspection

INFOID:000000012423353

1. CHECK DOOR MIRROR DEFOGGER RH

1. Turn ignition switch OFF.
2. Disconnect door mirror RH.
3. Check continuity between door mirror terminals.

Terminal		Continuity
2	10	Yes

Is the inspection result normal?

- YES >> Inspection End.
- NO >> Replace door mirror RH. Refer to [MIR-22, "Removal and Installation"](#).

DEFOGGER SYSTEM SYMPTOMS

< SYMPTOM DIAGNOSIS >

SYMPTOM DIAGNOSIS

DEFOGGER SYSTEM SYMPTOMS

Symptom Table

INFOID:0000000012423354

Symptom	Reference page
Rear window defogger and door mirror defoggers* do not operate.	Refer to DEF-34, "Diagnosis Procedure" .
Rear window defogger does not operate but both of the door mirror defoggers* operate.	Refer to DEF-35, "Diagnosis Procedure" .
Both door mirror defoggers* don't operate but rear window defogger operates.	Refer to DEF-36, "Diagnosis Procedure" .
Driver side door mirror defogger* does not operate.	Refer to DEF-37, "Diagnosis Procedure" .
Passenger side door mirror defogger* does not operate.	Refer to DEF-38, "Diagnosis Procedure" .
Rear window defogger switch does not light, but rear window defogger operates.	Refer to DEF-39, "Diagnosis Procedure" .

*:if equipped

A
B
C
D
E
F
G
H
I
J
K
DEF
M
N
O
P

REAR WINDOW DEFOGGER AND DOOR MIRROR DEFOGGER DO NOT OPERATE.

< SYMPTOM DIAGNOSIS >

REAR WINDOW DEFOGGER AND DOOR MIRROR DEFOGGER DO NOT OPERATE.

Diagnosis Procedure

INFOID:000000012423355

Regarding Wiring Diagram information, refer to [DEF-14, "Wiring Diagram"](#).

1. CHECK REAR WINDOW DEFOGGER SWITCH

Check rear window defogger switch.

Refer to [DEF-23, "WITH MANUAL A/C : Component Function Check"](#).

Is the inspection result normal?

YES >> GO TO 2.

NO >> Repair or replace the malfunctioning parts.

2. CHECK REAR WINDOW DEFOGGER RELAY

Check rear window defogger relay.

Refer to [DEF-25, "Component Function Check"](#).

Is the inspection result normal?

YES >> GO TO 3.

NO >> Repair or replace the malfunctioning parts.

3. CHECK REAR WINDOW DEFOGGER POWER SUPPLY AND GROUND CIRCUIT

Check rear window defogger power supply and ground circuit.

Refer to [DEF-27, "Component Function Check"](#).

Is the inspection result normal?

YES >> GO TO 4.

NO >> Repair or replace the malfunctioning parts.

4. CHECK DOOR MIRROR DEFOGGER POWER SUPPLY

1. Turn ignition switch ON.
2. Check voltage between fuse block (J/B) connector and ground.

(+)		(-)	Condition	Voltage (V) (Approx.)
Fuse block (J/B)	Connector			
	Terminal	Ground	Rear window defogger switch	Battery voltage
M44	4P, 5P		ON	OFF

Is the inspection result normal?

YES >> GO TO 5.

NO >> Replace fuse block (J/B).

5. CHECK BOTH DOOR MIRROR DEFOGGER

1. Check door mirror LH. Refer to [DEF-29, "Component Function Check"](#).
2. Check door mirror RH. Refer to [DEF-31, "Component Function Check"](#).

Is the inspection result normal?

YES >> Check intermittent incident. Refer to [GI-45, "Intermittent Incident"](#).

NO >> Repair or replace the malfunctioning parts.

REAR WINDOW DEFOGGER DOES NOT OPERATE BUT BOTH OF DOOR MIRROR DEFOGGER OPERATE.

< SYMPTOM DIAGNOSIS >

REAR WINDOW DEFOGGER DOES NOT OPERATE BUT BOTH OF DOOR MIRROR DEFOGGER OPERATE.

Diagnosis Procedure

INFOID:000000012423356

1. CHECK REAR WINDOW DEFOGGER POWER SUPPLY AND GROUND CIRCUIT

Check rear window defogger power supply and ground circuit.

Refer to [DEF-27, "Component Function Check"](#).

Is the inspection result normal?

YES >> Refer to [GI-45, "Intermittent Incident"](#).

NO >> Repair or replace the malfunctioning parts.

A
B
C
D
E
F
G
H
I
J
K
DEF
M
N
O
P

BOTH DOORS MIRROR DEFOGGER DON'T OPERATE BUT REAR WINDOW DEFOGGER OPERATES

< SYMPTOM DIAGNOSIS >

BOTH DOORS MIRROR DEFOGGER DON'T OPERATE BUT REAR WINDOW DEFOGGER OPERATES

Diagnosis Procedure

INFOID:000000012423357

Regarding Wiring Diagram information, refer to [DEF-14, "Wiring Diagram"](#).

1. CHECK DOOR MIRROR DEFOGGER FUSE

Check if the following fuse is blown.

Location	Capacity	Fuse No.
Fuse block (J/B)	10A	22

Is the inspection result normal?

YES >> GO TO 2.

NO >> Replace the blown fuse after repairing the affected circuit.

2. CHECK DOOR MIRROR DEFOGGER POWER SUPPLY CIRCUIT

1. Turn ignition switch ON.
2. Check voltage between fuse block (J/B) harness connector and ground.

(+)		(-)	Condition	Voltage (V) (Approx.)	
Connector	Terminal				
M44	4P, 5P	Ground	Rear window defogger switch	ON	Battery voltage
			OFF	0	

Is the inspection result normal?

YES >> GO TO 3.

NO >> Replace fuse block (J/B).

3. CHECK BOTH DOOR MIRROR DEFOGGER

1. Check door mirror LH. Refer to [DEF-29, "Component Function Check"](#).
2. Check door mirror RH. Refer to [DEF-31, "Component Function Check"](#).

Is the inspection result normal?

YES >> Check intermittent incident. Refer to [GI-45, "Intermittent Incident"](#).

NO >> Repair or replace the malfunctioning parts.

DRIVER SIDE DOOR MIRROR DEFOGGER DOES NOT OPERATE.

< SYMPTOM DIAGNOSIS >

DRIVER SIDE DOOR MIRROR DEFOGGER DOES NOT OPERATE.

Diagnosis Procedure

INFOID:000000012423358

1. CHECK DOOR MIRROR DEFOGGER LH

Check door mirror defogger LH.

Refer to [DEF-29, "Component Function Check"](#).

Is the inspection result normal?

YES >> Refer to [GI-45, "Intermittent Incident"](#).

NO >> Repair or replace the malfunctioning parts.

A
B
C
D
E
F
G
H
I
J
K
DEF
M
N
O
P

PASSENGER SIDE DOOR MIRROR DEFOGGER DOES NOT OPERATE.

< SYMPTOM DIAGNOSIS >

PASSENGER SIDE DOOR MIRROR DEFOGGER DOES NOT OPERATE.

Diagnosis Procedure

INFOID:000000012423359

1. CHECK DOOR MIRROR DEFOGGER RH

Check door mirror defogger RH.

Refer to [DEF-31, "Component Function Check"](#).

Is the inspection result normal?

YES >> Refer to [GI-45, "Intermittent Incident"](#).

NO >> Repair or replace the malfunctioning parts.

REAR WINDOW DEFOGGER SWITCH DOES NOT LIGHT, BUT REAR WINDOW DEFOGGER OPERATES

< SYMPTOM DIAGNOSIS >

REAR WINDOW DEFOGGER SWITCH DOES NOT LIGHT, BUT REAR WINDOW DEFOGGER OPERATES

Diagnosis Procedure

INFOID:000000012423360

1. CHECK REAR WINDOW DEFOGGER SWITCH

Check that the rear window defogger switch is operating normally.

Is the inspection result normal?

YES >> Refer to [GI-45, "Intermittent Incident"](#).

NO >> Refer to [DEF-23, "WITH MANUAL A/C : Diagnosis Procedure"](#) or [DEF-23, "WITH AUTO A/C : Diagnosis Procedure"](#).

A
B
C
D
E
F
G
H
I
J
K
DEF
M
N
O
P

FILAMENT

< REMOVAL AND INSTALLATION >

REMOVAL AND INSTALLATION

FILAMENT

Inspection and Repair

INFOID:000000012423361

INSPECTION

1. When measuring voltage, wrap tin foil around the top of the negative probe. Then press the foil against the wire with your finger.

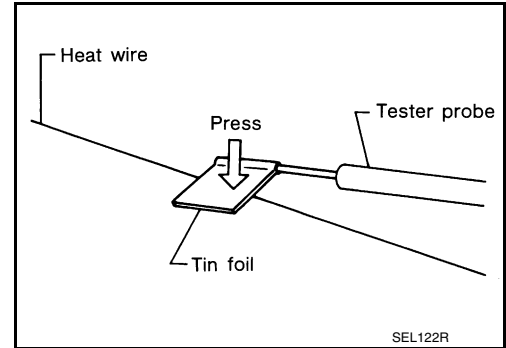

2. Attach probe circuit tester (in Volt range) to middle portion of each filament.

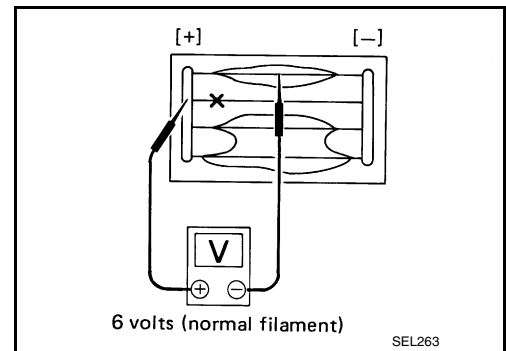

3. If a filament is burned out, circuit tester registers 0 or battery voltage.
4. To locate burned out point, move probe to left and right along filament. Test needle will swing abruptly when probe passes the point.

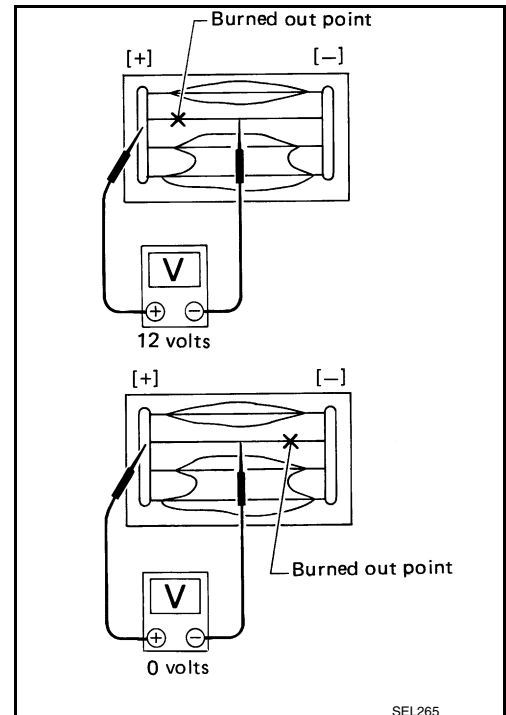

REPAIR

REPAIR EQUIPMENT

- Conductive silver composition (Dupont No. 4817 or equivalent)

FILAMENT

< REMOVAL AND INSTALLATION >

- Ruler 30 cm (11.8 in) long
- Drawing pen
- Heat gun
- Alcohol
- Cloth

REPAIRING PROCEDURE

1. Wipe broken heat wire and its surrounding area clean with a cloth dampened in alcohol.
2. Apply a small amount of conductive silver composition to tip of drawing pen. Shake silver composition container before use.
3. Place ruler on glass along broken line. Deposit conductive silver composition on break with drawing pen. Slightly overlap existing heat wire on both sides [preferably 5 mm (0.20 in)] of the break.

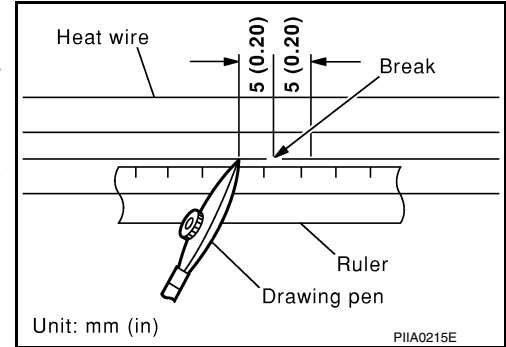

4. After repair has been completed, check repaired wire for continuity. This check should be conducted 10 minutes after silver composition is deposited. Do not touch repaired area while test is being conducted.

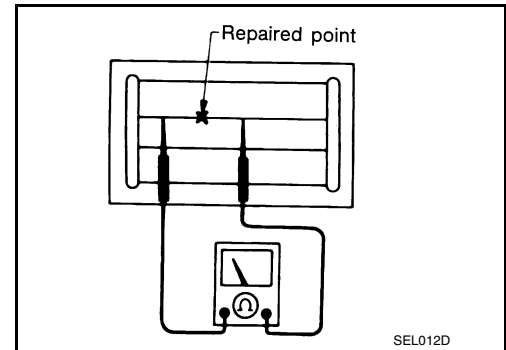

5. Apply a constant stream of hot air directly to the repaired area for approximately 20 minutes with a heat gun. A minimum distance of 3 cm (1.2 in) should be kept between repaired area and hot air outlet. If a heat gun is not available, let the repaired area dry for 24 hours.

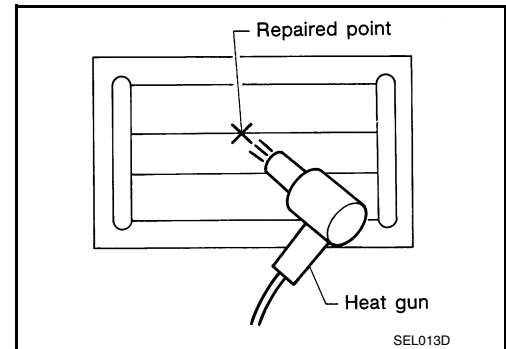

CONDENSER

< REMOVAL AND INSTALLATION >

CONDENSER

Removal and Installation

INFOID:000000012423362

REMOVAL

1. Remove luggage side upper finisher (LH/RH). Refer to [INT-36. "LUGGAGE SIDE UPPER FINISHER : Removal and Installation"](#).
2. Remove headlining clips (A) using suitable tool (B) and partially lower headlining (rear).

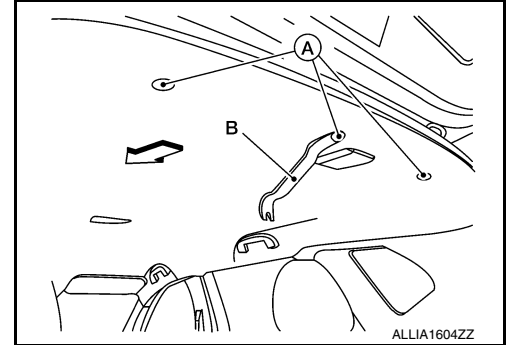

3. Disconnect the harness connectors from the condenser.
4. Remove the bolt (A) and the condenser (1).

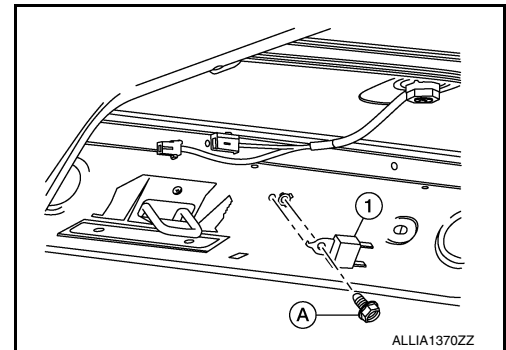

INSTALLATION

Installation is in the reverse order of removal.