

A

SECTION STR

STR

STARTING SYSTEM

C

CONTENTS

D

PRECAUTION	2		
PRECAUTIONS	2	Work Flow (Without GR8-1200 NI)	15
Precaution for Supplemental Restraint System (SRS) "AIR BAG" and "SEAT BELT PRE-TENSIONER"	2	DTC/CIRCUIT DIAGNOSIS	17
PREPARATION	3	B TERMINAL CIRCUIT	17
PREPARATION	3	Description	17
Special Service Tools	3	Diagnosis Procedure	17
Commercial Service Tools	3	S CONNECTOR CIRCUIT	19
SYSTEM DESCRIPTION	4	Description	19
COMPONENT PARTS	4	Diagnosis Procedure	19
Component Parts Location	4	SYMPTOM DIAGNOSIS	20
SYSTEM	6	STARTING SYSTEM	20
System Description	6	Symptom Table	20
WIRING DIAGRAM	7	REMOVAL AND INSTALLATION	21
STARTING SYSTEM	7	STARTER MOTOR	21
Wiring Diagram	7	Exploded View	21
BASIC INSPECTION	11	Removal and Installation	21
DIAGNOSIS AND REPAIR WORKFLOW	11	SERVICE DATA AND SPECIFICATIONS (SDS)	22
Work Flow (With GR8-1200 NI)	11	SERVICE DATA AND SPECIFICATIONS (SDS)	22
		Starter Motor	22

PRECAUTIONS

< PRECAUTION >

PRECAUTION

PRECAUTIONS

Precaution for Supplemental Restraint System (SRS) "AIR BAG" and "SEAT BELT PRE-TENSIONER"

INFOID:000000012429680

The Supplemental Restraint System such as "AIR BAG" and "SEAT BELT PRE-TENSIONER", used along with a front seat belt, helps to reduce the risk or severity of injury to the driver and front passenger for certain types of collision. Information necessary to service the system safely is included in the SR and SB section of this Service Manual.

WARNING:

- To avoid rendering the SRS inoperative, which could increase the risk of personal injury or death in the event of a collision which would result in air bag inflation, all maintenance must be performed by an authorized NISSAN/INFINITI dealer.
- Improper maintenance, including incorrect removal and installation of the SRS, can lead to personal injury caused by unintentional activation of the system. For removal of Spiral Cable and Air Bag Module, see the SR section.
- Do not use electrical test equipment on any circuit related to the SRS unless instructed to in this Service Manual. SRS wiring harnesses can be identified by yellow and/or orange harnesses or harness connectors.

PRECAUTIONS WHEN USING POWER TOOLS (AIR OR ELECTRIC) AND HAMMERS

WARNING:

- When working near the Airbag Diagnosis Sensor Unit or other Airbag System sensors with the Ignition ON or engine running, DO NOT use air or electric power tools or strike near the sensor(s) with a hammer. Heavy vibration could activate the sensor(s) and deploy the air bag(s), possibly causing serious injury.
- When using air or electric power tools or hammers, always switch the Ignition OFF, disconnect the battery and wait at least three minutes before performing any service.

PREPARATION

< PREPARATION >

PREPARATION

PREPARATION

Special Service Tools

INFOID:0000000012429681

A

STR

The actual shape of the tools may differ from those illustrated here.

Tool number (TechMate No.) Tool name	Description
<p>— (165-GR8-1200KIT-NI) Nissan battery and electronics tester</p>  <p>AWIIA1239ZZ</p>	<p>Testing batteries, starting and charging systems and charges batteries. For operating instructions, refer to diagnostic station instruction manual.</p>

C

D

E

Commercial Service Tools

INFOID:0000000012429682

Tool name	Description
<p>Power tool</p>  <p>PIIB1407E</p>	<p>Loosening bolts, nuts and screws</p>

F

G

H

I

J

K

L

M

N

O

P

COMPONENT PARTS

< SYSTEM DESCRIPTION >

SYSTEM DESCRIPTION

COMPONENT PARTS

Component Parts Location

INFOID:000000012429683

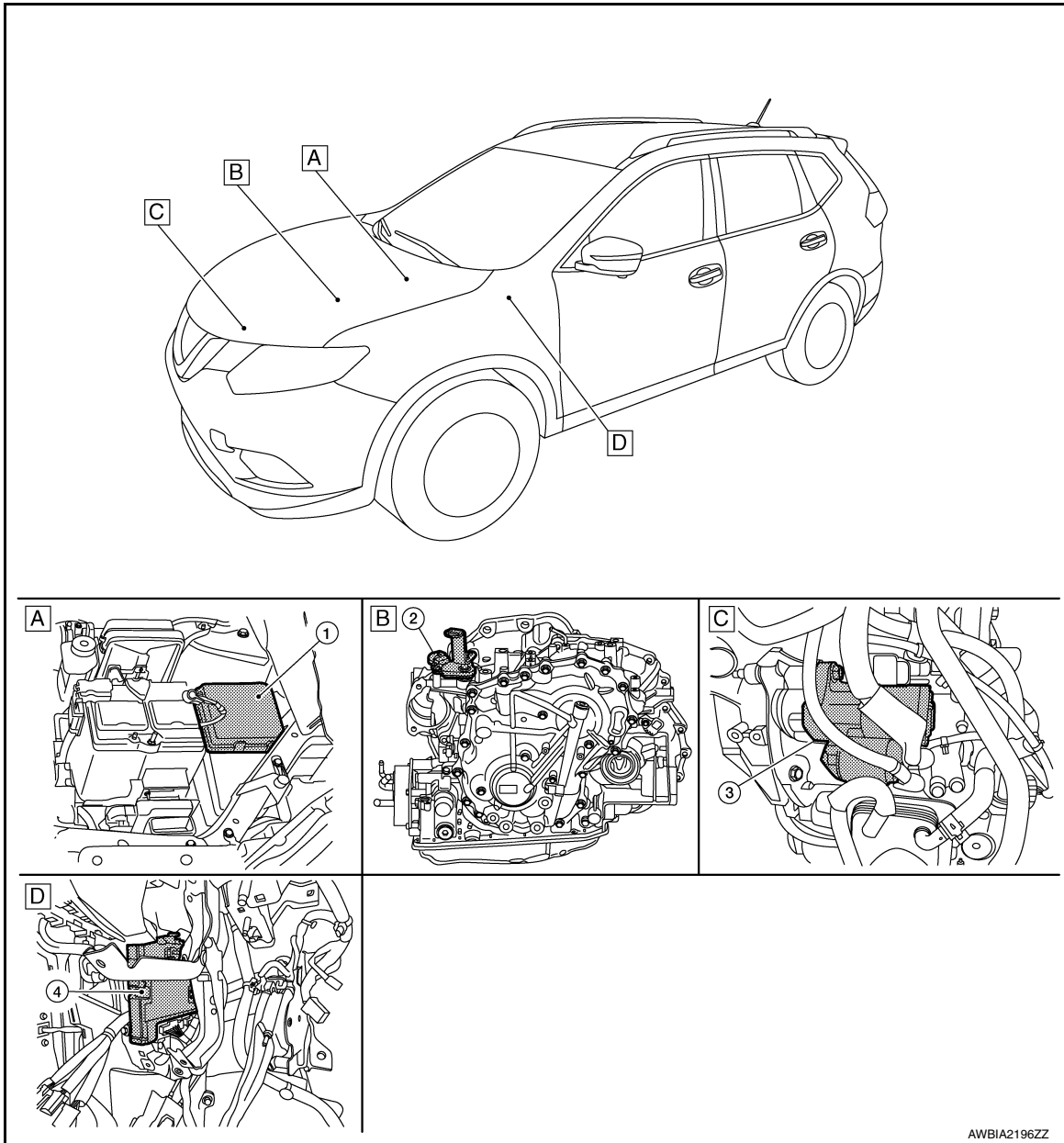

AWBIA2196ZZ

- A. Engine room (RH) B. View with transmission removed C. View with engine and transmission removed
- D. Behind instrument panel (LH)

No.	Component part	Description
1.	IPDM E/R	CPU inside IPDM E/R operates the starter relay when the ignition switch is in the start position.
2.	Transmission range switch	Transmission range switch supplies power to the starter relay and starter control relay inside the IPDM E/R when the selector lever is shifted to the P (Park) or N (Neutral) position.

COMPONENT PARTS

< SYSTEM DESCRIPTION >

No.	Component part	Description
3.	Starter motor	The starter motor plunger closes and the motor is supplied with battery power, which in turn cranks the engine, when the S terminals supplied with electric power.
4.	BCM	BCM controls the starter relay inside IPDM E/R.

A

STR

C

D

E

F

G

H

I

J

K

L

M

N

O

P

SYSTEM

< SYSTEM DESCRIPTION >

SYSTEM

System Description

INFOID:000000012429684

The starter motor plunger closes and provides a closed circuit between the battery and the starter motor. The starter motor is grounded to the cylinder block. With power and ground supplied, the starter motor operates.

SYSTEM DIAGRAM

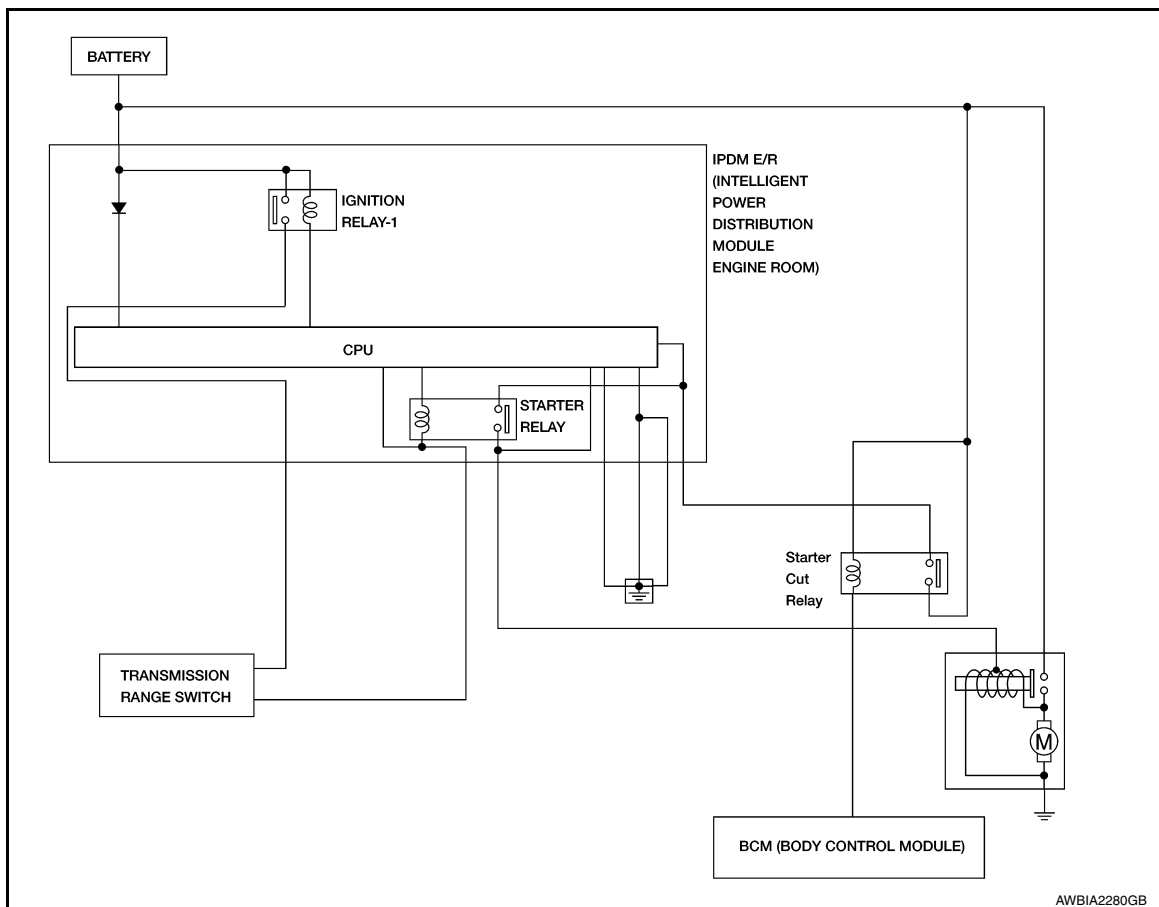

STARTING SYSTEM

< WIRING DIAGRAM >

WIRING DIAGRAM

STARTING SYSTEM

Wiring Diagram

INFOID:000000012429685

A

STR

C

D

E

F

G

H

I

J

K

L

M

N

O

P

STARTING SYSTEM

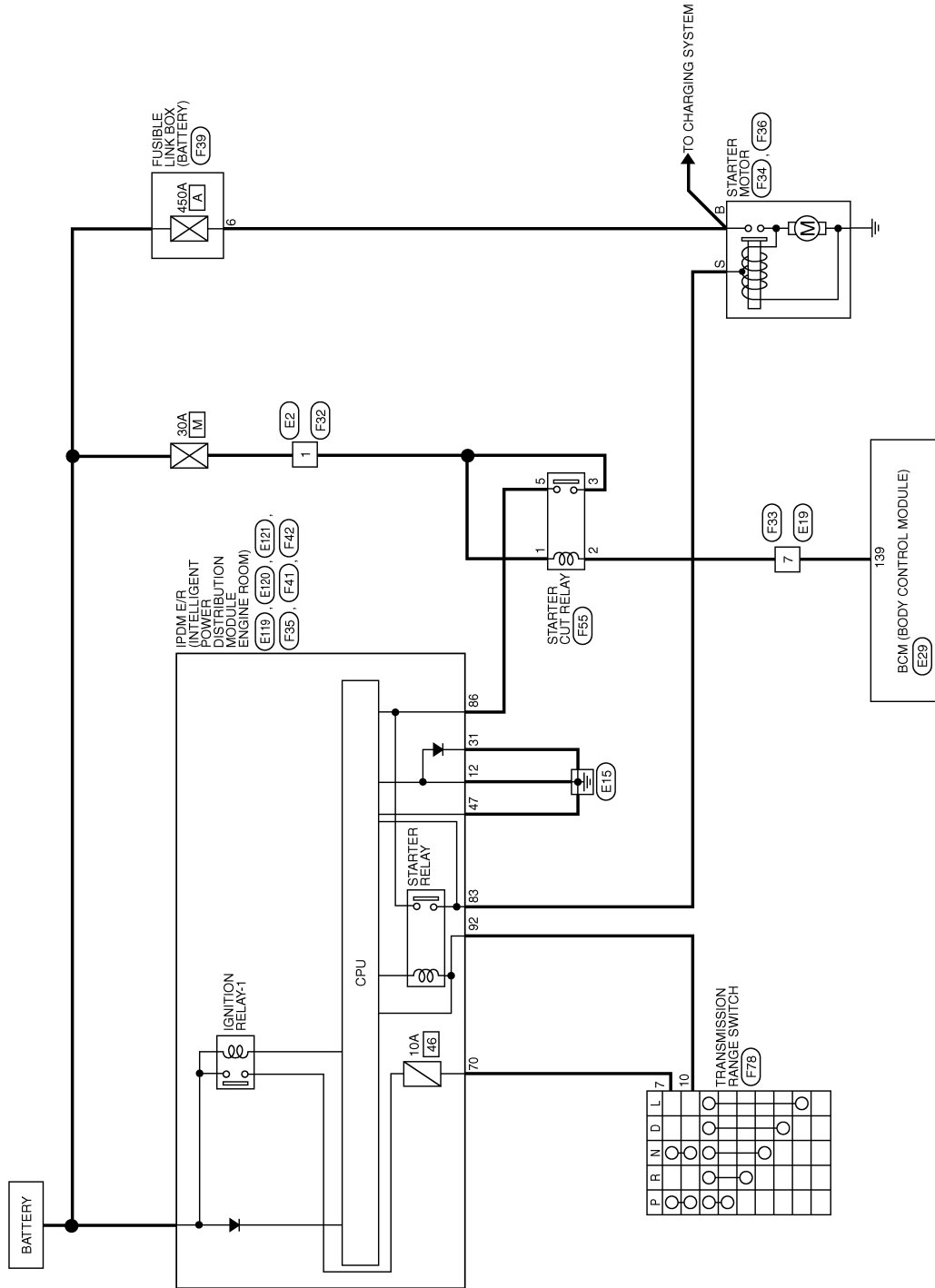

AABWA1045GB

STARTING SYSTEM

< WIRING DIAGRAM >

STARTING SYSTEM CONNECTORS

Connector No.	E2
Connector Name	WIRE TO WIRE
Connector Color	WHITE



1	2	3	4	5	6	7
8	9	10	11	12	13	14
15	16					

Terminal No.	1	Color of Wire	L	Signal Name	-
--------------	---	---------------	---	-------------	---

Connector No.	E19
Connector Name	WIRE TO WIRE
Connector Color	BROWN



1	2	3	4	5	6	7
8	9	10	11	12	13	14
15	16					

Terminal No.	7	Color of Wire	G	Signal Name	-
--------------	---	---------------	---	-------------	---

Connector No.	E29
Connector Name	BCM (BODY CONTROL MODULE)
Connector Color	BLACK



132	131	130	129	128	127	126	125	124	123	122	121
144	143	142	141	140	139	138	137	136	135	134	133

Terminal No.	139	Color of Wire	G	Signal Name	O STCUT RL
--------------	-----	---------------	---	-------------	------------

Connector No.	E119
Connector Name	IPDM E/R (INTELLIGENT POWER DISTRIBUTION MODULE ENGINE ROOM)
Connector Color	GRAY



9	8	7	6	5	4	3
18	17	16	15	14	13	12
11	10					

Terminal No.	12	Color of Wire	B	Signal Name	SIGNAL GROUND
--------------	----	---------------	---	-------------	---------------

Connector No.	E120
Connector Name	IPDM E/R (INTELLIGENT POWER DISTRIBUTION MODULE ENGINE ROOM)
Connector Color	GRAY



30	29	28	27	26	25	24	23	22	21	20	19
42	41	40	39	38	37	36	35	34	33	32	31

Terminal No.	31	Color of Wire	B	Signal Name	2ND SIGNAL GROUND
--------------	----	---------------	---	-------------	-------------------

Connector No.	E121
Connector Name	IPDM E/R (INTELLIGENT POWER DISTRIBUTION MODULE ENGINE ROOM)
Connector Color	RED



45	44	43
48	47	46

Terminal No.	47	Color of Wire	B	Signal Name	POWER GROUND
--------------	----	---------------	---	-------------	--------------

STARTING SYSTEM

< WIRING DIAGRAM >

Connector No.	F34
Connector Name	STARTER MOTOR
Connector Color	-



Terminal No.	S	Color of Wire	G	Signal Name	-
--------------	---	---------------	---	-------------	---

Connector No.	F33
Connector Name	WIRE TO WIRE
Connector Color	BROWN

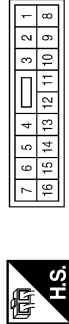

Terminal No.	7	Color of Wire	G	Signal Name	-
--------------	---	---------------	---	-------------	---

Connector No.	F32
Connector Name	WIRE TO WIRE
Connector Color	WHITE



Terminal No.	1	Color of Wire	L	Signal Name	-
--------------	---	---------------	---	-------------	---

Connector No.	F39
Connector Name	FUSIBLE LINK BOX (BATTERY)
Connector Color	-



Terminal No.	6	Color of Wire	B/R	Signal Name	-
--------------	---	---------------	-----	-------------	---

Connector No.	F36
Connector Name	STARTER MOTOR
Connector Color	-



Terminal No.	B	Color of Wire	B/R	Signal Name	-
--------------	---	---------------	-----	-------------	---

Connector No.	F35
Connector Name	IPDM E/R (INTELLIGENT POWER DISTRIBUTION MODULE ENGINE ROOM)
Connector Color	WHITE



Terminal No.	70	Color of Wire	BG	Signal Name	O IGN AT LPG
--------------	----	---------------	----	-------------	--------------

AABIA1219GB

A
STR
C
D
E
F
G
H
I
J
K
L
M
N
O
P

STARTING SYSTEM

< WIRING DIAGRAM >

Connector No.	F55
Connector Name	STARTER CUT RELAY
Connector Color	BLUE



Terminal No.	Color of Wire	Signal Name
1	SB	-
2	G	-
3	L	-
5	GR	-

Connector No.	F42
Connector Name	IPDM E/R (INTELLIGENT POWER DISTRIBUTION MODULE ENGINE ROOM)
Connector Color	BLACK

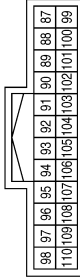

Terminal No.	Color of Wire	Signal Name
92	GR	LI NP SW

Connector No.	F41
Connector Name	IPDM E/R (INTELLIGENT POWER DISTRIBUTION MODULE ENGINE ROOM)
Connector Color	GRAY



Terminal No.	Color of Wire	Signal Name
83	G	O STARTER
86	GR	FL STARTER

Connector No.	F78
Connector Name	TRANSMISSION RANGE SWITCH
Connector Color	BLACK

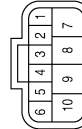

Terminal No.	Color of Wire	Signal Name
7	BG	-
10	GR	-

AABIA1220GB

DIAGNOSIS AND REPAIR WORKFLOW

< BASIC INSPECTION >

BASIC INSPECTION

DIAGNOSIS AND REPAIR WORKFLOW

Work Flow (With GR8-1200 NI)

INFOID:0000000012429686

A

STR

STARTING SYSTEM DIAGNOSIS WITH GR8-1200 NI

To test the starting system, use the following special service tool:

- GR8-1200 NI Multitasking battery and electrical diagnostic station

NOTE:

Refer to the diagnostic station Instruction Manual for proper starting system diagnosis procedures.

C

D

E

F

G

H

I

J

K

L

M

N

O

P

DIAGNOSIS AND REPAIR WORKFLOW

< BASIC INSPECTION >

OVERALL SEQUENCE

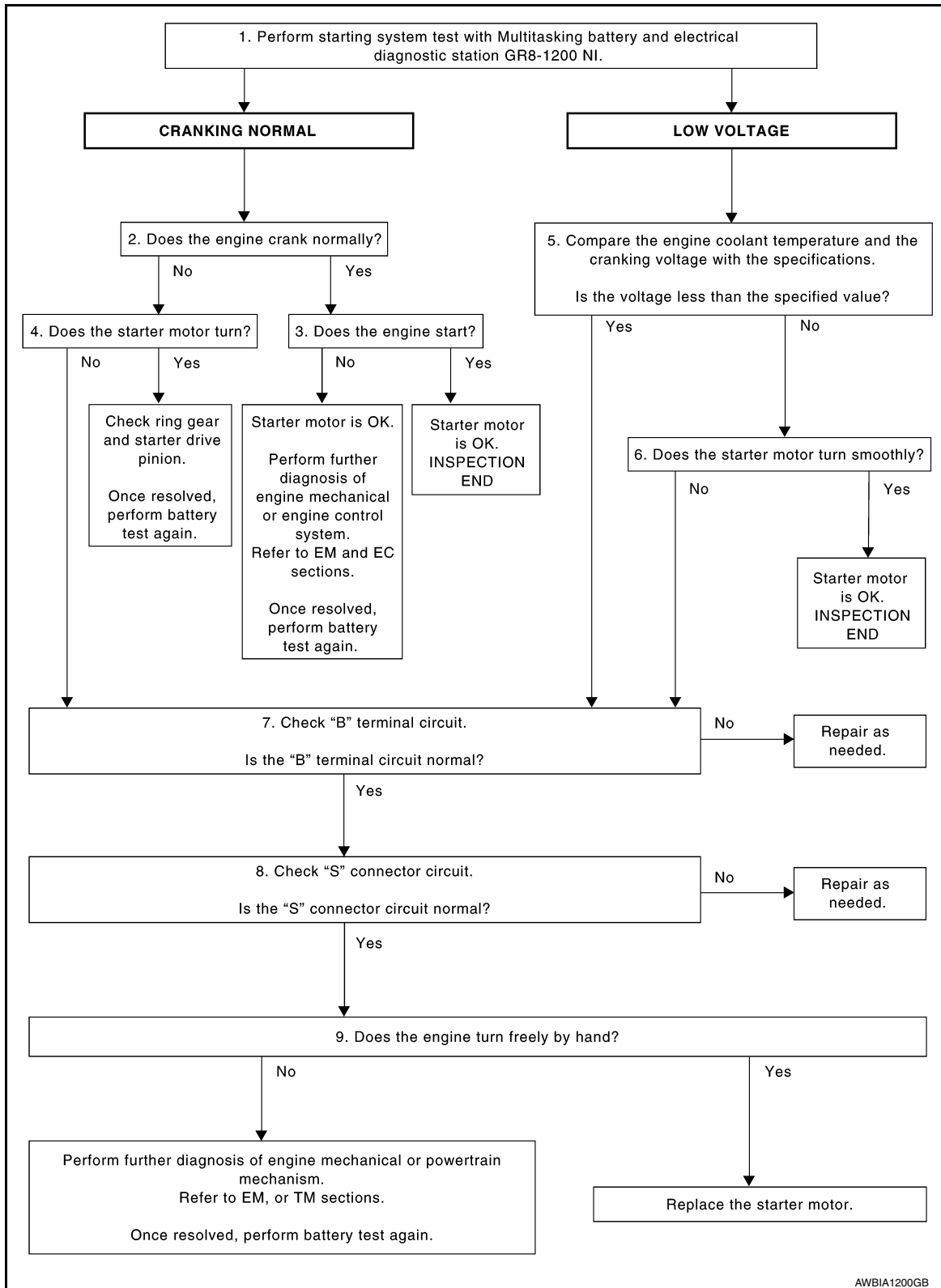

DETAILED FLOW

NOTE:

To ensure a complete and thorough diagnosis, the battery, starter motor and generator test segments must be done as a set from start to finish.

1. DIAGNOSIS WITH MULTITASKING BATTERY AND ELECTRICAL DIAGNOSTIC STATION GR8-1200 NI

DIAGNOSIS AND REPAIR WORKFLOW

< BASIC INSPECTION >

Perform the starting system test with Multitasking battery and electrical diagnostic station GR8-1200 NI. For details and operating instructions, refer to diagnostic station Instruction Manual.

Test result

CRANKING NORMAL>>GO TO 2.

LOW VOLTAGE>>GO TO 5.

CHARGE BATTERY>>Perform the slow battery charging procedure. (Initial rate of charge is 10A for 12 hours.) Perform battery test again. Refer to diagnostic station instruction manual.

REPLACE BATTERY>>Before replacing battery, clean the battery cable clamps and battery posts. Perform battery test again. Refer to diagnostic station instruction manual. If second test result is "REPLACE BATTERY", then do so. Perform battery test again to confirm repair.

2. CRANKING CHECK

Check that the starter motor operates properly.

Does the engine crank normally?

YES >> GO TO 3.

NO >> GO TO 4.

3. ENGINE START CHECK

Check that the engine starts.

Does the engine start?

YES >> Inspection End.

NO >> Perform further diagnosis of engine mechanical or engine control system. Refer to EM and EC sections. Once resolved, perform battery test again.

4. STARTER MOTOR ACTIVATION

Check that the starter motor operates.

Does the starter motor turn?

YES >> Check ring gear and starter motor drive pinion. Once resolved, perform battery test again.

NO >> GO TO 7.

5. COMPARISON BETWEEN ENGINE COOLANT AND CRANKING VOLTAGE

Compare the engine coolant temperature and verify the cranking voltage is within specifications.

Minimum Specification of Cranking Voltage Referencing Coolant Temperature

Engine coolant temperature [°C (°F)]	Voltage [V]
-30 to -20 (-22 to -4)	8.6
-19 to -10 (-2 to 14)	9.1
-9 to 0 (16 to 32)	9.5
More than 1 (More than 34)	9.9

Is the voltage less than the specified value?

YES >> GO TO 7.

NO >> GO TO 6.

6. STARTER OPERATION

Check the starter operation.

Does the starter motor turn smoothly?

YES >> Inspection End.

NO >> GO TO 7.

7. "B" TERMINAL CIRCUIT INSPECTION

Check "B" terminal circuit. Refer to [STR-17, "Diagnosis Procedure"](#).

Is "B" terminal circuit normal?

YES >> GO TO 8.

NO >> Repair as needed.

8. "S" CONNECTOR CIRCUIT INSPECTION

Check "S" connector circuit. Refer to [STR-19, "Diagnosis Procedure"](#).

DIAGNOSIS AND REPAIR WORKFLOW

< BASIC INSPECTION >

Is "S" connector circuit normal?

- YES >> GO TO 9.
- NO >> Repair as needed.

9.ENGINE ROTATION STATUS

Check that the engine can be rotated by hand.

Does the engine turn freely by hand?

- YES >> Replace starter motor. Refer to [STR-21, "Removal and Installation"](#).
- NO >> Perform further diagnosis of engine mechanical or powertrain mechanism. Once resolved, perform battery test again using Multitasking battery and electrical diagnostic station GR8-1200 NI. Refer to the diagnostic station Instruction Manual for proper testing procedures.

DIAGNOSIS AND REPAIR WORKFLOW

< BASIC INSPECTION >

Work Flow (Without GR8-1200 NI)

INFOID:000000012429687

A

OVERALL SEQUENCE

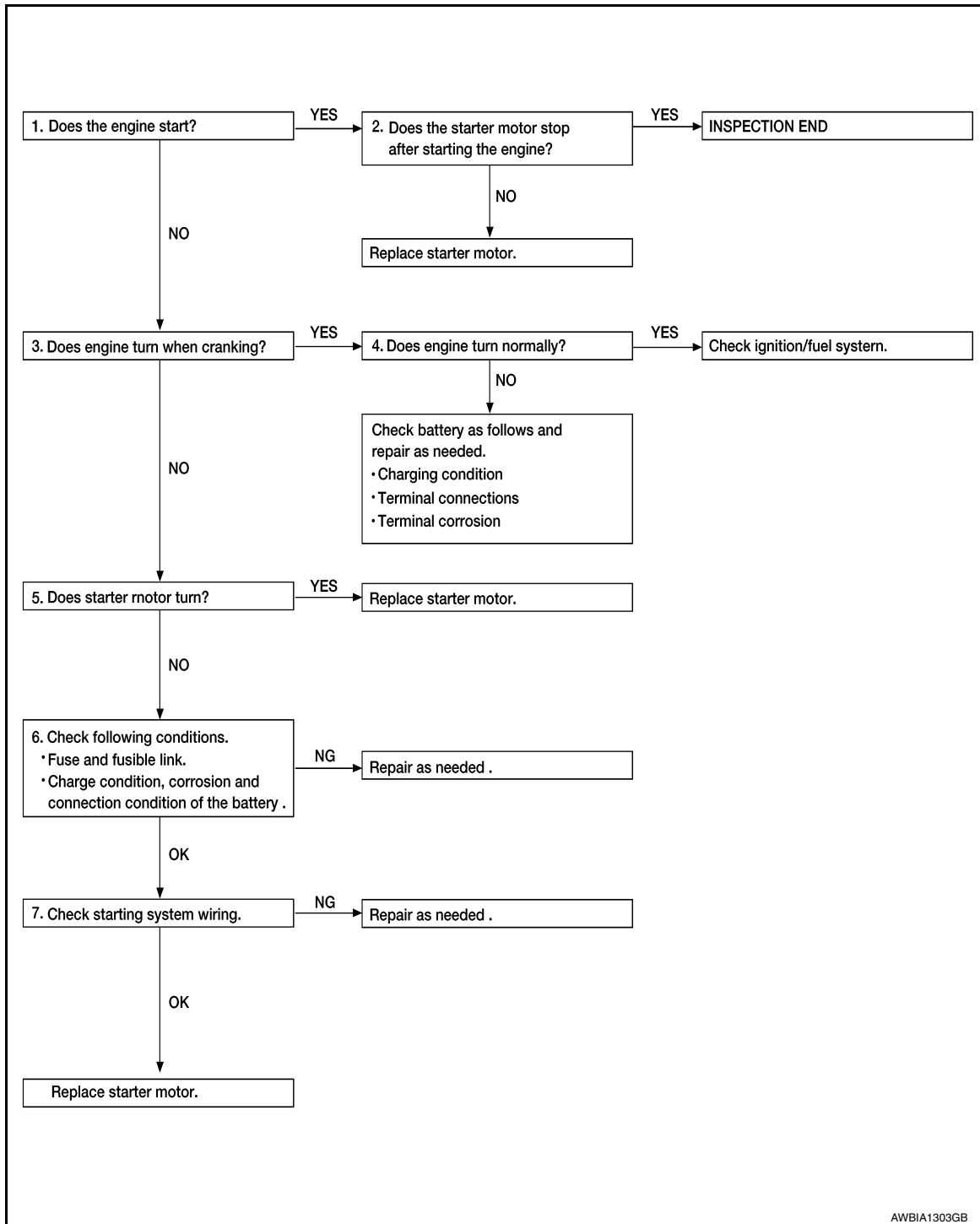

STR

C

D

E

F

G

H

I

J

K

L

M

N

O

P

DETAILED FLOW

NOTE:

If any malfunction is found, immediately disconnect the battery cable from the negative terminal.

1. CHECK ENGINE START

Crank the engine and check that the engine starts.

Does the engine start?

- YES >> GO TO 2.
- NO >> GO TO 3.

DIAGNOSIS AND REPAIR WORKFLOW

< BASIC INSPECTION >

2. CHECK THAT THE STARTER MOTOR STOPS

Check that the starter motor stops after starting the engine.

Does the starter motor stop?

YES >> Inspection End.

NO >> Replace starter motor. Refer to [STR-21, "Removal and Installation"](#).

3. CHECK THAT THE ENGINE TURNS WHEN CRANKING

Check that the engine turns when cranking.

Does engine turn when cranking?

YES >> GO TO 4.

NO >> GO TO 5.

4. CHECK THE ENGINE SPEED WHEN CRANKING

Check that the engine speed is not low when cranking.

Does engine turn normally?

YES >> Check ignition/fuel system.

NO >> Check charge condition, corrosion and connection condition of the battery.

5. CHECK STARTER MOTOR ACTIVATION

Check that the starter motor runs at cranking.

Does starter motor turn?

YES >> Replace starter motor. Refer to [STR-21, "Removal and Installation"](#).

NO >> GO TO 6.

6. CHECK POWER SUPPLY CIRCUIT

Check the following conditions:

- Fuse and fusible link
- Charge condition, corrosion and connection of the battery.

Are these inspection results normal?

YES >> GO TO 7.

NO >> Repair as needed.

7. CHECK STARTING SYSTEM WIRING

Check the following:

- "B" terminal circuit. Refer to [STR-17, "Diagnosis Procedure"](#).
- "S" terminal circuit. Refer to [STR-19, "Diagnosis Procedure"](#).

Are the inspection results normal?

YES >> Replace starter motor. Refer to [STR-21, "Removal and Installation"](#).

NO >> Repair as needed.

B TERMINAL CIRCUIT

< DTC/CIRCUIT DIAGNOSIS >

DTC/CIRCUIT DIAGNOSIS

B TERMINAL CIRCUIT

Description

INFOID:0000000012429688

STR

Terminal "B" is constantly supplied with battery power.

Diagnosis Procedure

INFOID:0000000012429689

Regarding Wiring Diagram information, refer to [STR-7. "Wiring Diagram"](#).

CAUTION:

Perform diagnosis under the condition that the engine cannot start by the following procedure.

1. Remove fuel pump fuse.
2. Crank or start the engine (where possible) until the fuel pressure is released.

1. CHECK "B" TERMINAL CIRCUIT

1. Turn ignition switch OFF.
2. Check that starter motor "B" terminal connection is clean and tight.
3. Check voltage between starter motor "B" terminal and ground.

Terminals		Voltage (Approx.)
(+)	(-)	
Starter motor "B" terminal	Terminal	Battery voltage
F36	B	
		Ground

Is the inspection result normal?

YES >> GO TO 2.

NO >> Check harness between battery and starter motor for open circuit.

2. CHECK BATTERY CABLE CONNECTION STATUS (VOLTAGE DROP TEST)

1. Shift selector lever to "P" (Park) or "N" (Neutral) position.
2. Check voltage between battery positive terminal and starter motor "B" terminal.

Terminals		Condition	Voltage (Approx.)
(+)	(-)		
	Starter motor "B" terminal	When the ignition switch is in START position	Less than 0.5V
Battery positive terminal	F36		
	Terminal		
	B		

Is the inspection result normal?

YES >> GO TO 3.

NO >> Check harness between the battery and starter motor for continuity.

3. CHECK GROUND CIRCUIT STATUS (VOLTAGE DROP TEST)

1. Shift selector lever to "P" (Park) or "N" (Neutral) position.
2. Check voltage between starter motor case and battery negative terminal.

Terminals		Condition	Voltage (Approx.)
(+)	(-)		
Starter motor case	Battery negative terminal	When the ignition switch is in START position	Less than 0.2V

Is the inspection result normal?

B TERMINAL CIRCUIT

< DTC/CIRCUIT DIAGNOSIS >

- YES >> "B" terminal circuit is OK. Further inspection is necessary. Refer to [STR-11, "Work Flow \(With GR8-1200 NI\)"](#) or [STR-15, "Work Flow \(Without GR8-1200 NI\)"](#).
- NO >> Check the starter motor case to engine mounting for high resistance.

S CONNECTOR CIRCUIT

< DTC/CIRCUIT DIAGNOSIS >

S CONNECTOR CIRCUIT

Description

INFOID:000000012429690

The starter motor magnetic switch is supplied with power when the ignition switch is turned to the START position while the selector lever is in the P (Park) or N (Neutral) position.

STR

Diagnosis Procedure

INFOID:000000012429691

Regarding Wiring Diagram information, refer to [STR-7, "Wiring Diagram"](#).

CAUTION:

Perform diagnosis under the condition that engine cannot start by the following procedure.

1. Remove fuel pump fuse.
2. Crank or start the engine (where possible) until the fuel pressure is released.

1. CHECK "S" CONNECTOR CIRCUIT

1. Turn ignition switch OFF.
2. Disconnect starter motor connector.
3. Shift selector lever to "P" (Park) or "N" (Neutral) position.
4. Check voltage between starter motor harness connector and ground.

(+)		(-)	Condition	Voltage (Approx.)
Connector	Terminal			
F34	S	Ground	When the ignition switch is in START position	Battery voltage

Is the inspection result normal?

YES >> "S" circuit is OK. Further inspection is necessary. Refer to [STR-11, "Work Flow \(With GR8-1200 NI\)"](#) or [STR-15, "Work Flow \(Without GR8-1200 NI\)"](#).

NO >> GO TO 2.

2. CHECK HARNESS CONTINUITY (OPEN CIRCUIT)

1. Disconnect IPDM E/R connector.
2. Check continuity between starter motor harness connector and the IPDM E/R harness connector.

Starter motor harness connector		IPDM E/R harness connector		Continuity
Connector	Terminal	Connector	Terminal	
F34	S	F41	83	Yes

3. Check continuity between starter motor terminal S and ground.

Connector	Terminal	—	Continuity
F34	S	Ground	No

Is the inspection result normal?

YES >> Further inspection is necessary. Refer to [STR-11, "Work Flow \(With GR8-1200 NI\)"](#) or [STR-15, "Work Flow \(Without GR8-1200 NI\)"](#).

NO >> Repair or replace the harness or connectors.

STARTING SYSTEM

< SYMPTOM DIAGNOSIS >

SYMPTOM DIAGNOSIS

STARTING SYSTEM

Symptom Table

INFOID:000000012429692

Symptom	Reference
No normal cranking	Refer to STR-11. "Work Flow (With GR8-1200 NI)" or STR-15. "Work Flow (Without GR8-1200 NI)" .
Starter motor does not rotate	

STARTER MOTOR

< REMOVAL AND INSTALLATION >

REMOVAL AND INSTALLATION

STARTER MOTOR

Exploded View

INFOID:0000000012429693

A

STR

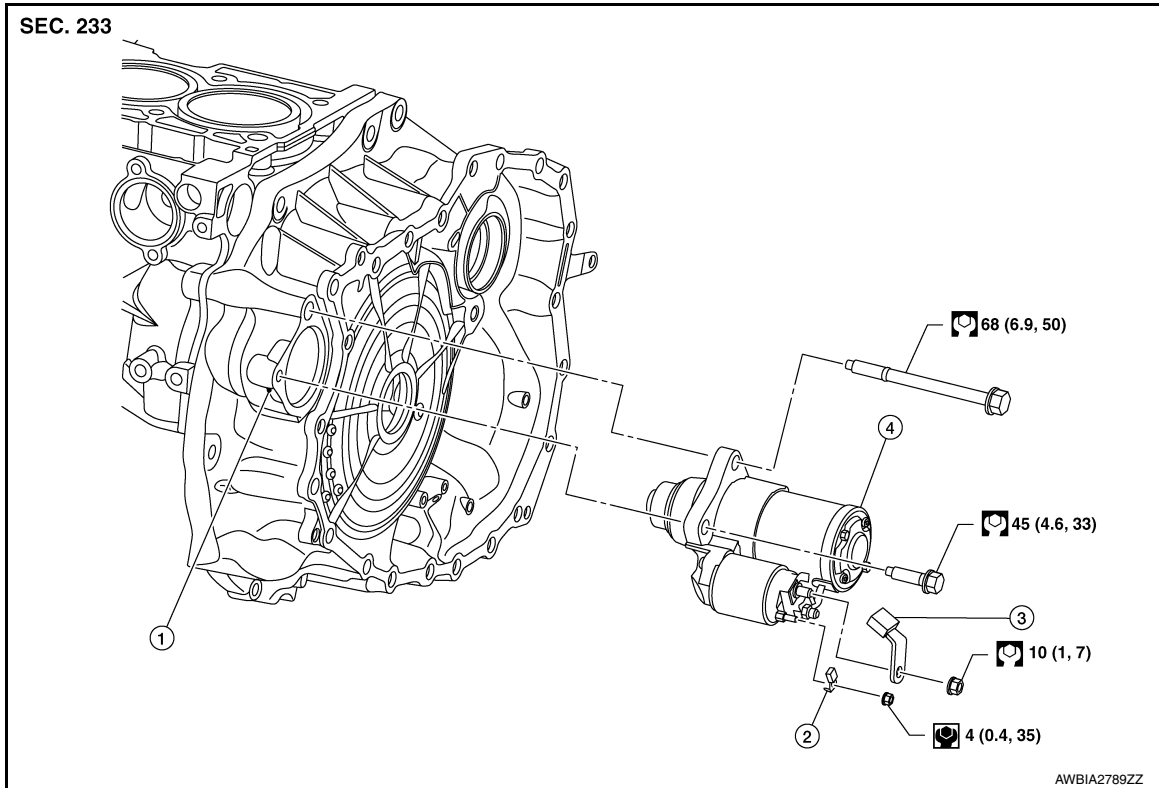

C

D

E

F

G

H

I

J

1. Transaxle assembly
2. "B" terminal harness
3. "S" connector
4. Starter motor

K

Removal and Installation

INFOID:0000000012429694

REMOVAL

1. Remove battery tray. Refer to [PG-81, "Removal and Installation \(Battery Tray\)"](#).
2. Remove terminal B nut and terminal B harness.
3. Remove terminal S nut and terminal S harness.
4. Remove starter motor mounting bolts.
5. Remove starter motor upward from the vehicle.

L

M

N

INSTALLATION

Installation is in the reverse order of removal.

NOTE:

- Perform the "Throttle Valve Closed Position Learning". Refer to [EC-143, "Work Procedure"](#).
- Perform the "Accelerator Pedal Released Position Learning". Refer to [EC-142, "Work Procedure"](#).

O

P

SERVICE DATA AND SPECIFICATIONS (SDS)

< SERVICE DATA AND SPECIFICATIONS (SDS)

SERVICE DATA AND SPECIFICATIONS (SDS)

SERVICE DATA AND SPECIFICATIONS (SDS)

Starter Motor

INFOID:0000000012429695

Applied model		QR25DE
Type*		M000TB0071ZC
		MITSUBISHI
		Reduction gear type
System voltage	[V]	12
No-load	Terminal voltage	[V] 11
	Current	[A] 90 Maximum
	Revolution	[rpm] 2,370 Minimum

*: Always check with the Parts Department for the latest parts information.