

WT
SECTION
ROAD WHEELS & TIRES

A
B
C
D

WT

CONTENTS

<p>PRECAUTION 3</p> <p>PRECAUTIONS 3</p> <p style="padding-left: 20px;">Precaution for Supplemental Restraint System (SRS) "AIR BAG" and "SEAT BELT PRE-TENSIONER"3</p> <p style="padding-left: 20px;">Service Notice and Precautions for TPMS3</p> <p style="padding-left: 20px;">Service Notice and Precautions for Road Wheel3</p> <p>PREPARATION 5</p> <p>PREPARATION 5</p> <p style="padding-left: 20px;">Special Service Tool5</p> <p style="padding-left: 20px;">Commercial Service Tool5</p> <p>SYSTEM DESCRIPTION 6</p> <p>COMPONENT PARTS 6</p> <p style="padding-left: 20px;">Component Parts Location6</p> <p style="padding-left: 20px;">BCM7</p> <p style="padding-left: 20px;">Information Display7</p> <p style="padding-left: 20px;">Tire Pressure Sensor8</p> <p>SYSTEM 9</p> <p style="padding-left: 20px;">System Description9</p> <p style="padding-left: 20px;">Easy Fill Tire Alert Function 11</p> <p>DIAGNOSIS SYSTEM (TIRE PRESSURE MONITORING SYSTEM)13</p> <p style="padding-left: 20px;">CONSULT Function 13</p> <p>ECU DIAGNOSIS INFORMATION15</p> <p>TIRE PRESSURE MONITORING SYSTEM15</p> <p style="padding-left: 20px;">Reference Value 15</p> <p style="padding-left: 20px;">DTC Inspection Priority Chart 15</p> <p style="padding-left: 20px;">DTC Index 16</p> <p>BCM18</p> <p style="padding-left: 20px;">List of ECU Reference 18</p> <p>WIRING DIAGRAM19</p>	<p>TIRE PRESSURE MONITORING SYSTEM19</p> <p style="padding-left: 20px;">Wiring Diagram19</p> <p>BASIC INSPECTION24</p> <p>DIAGNOSIS AND REPAIR WORK FLOW24</p> <p style="padding-left: 20px;">Work Flow24</p> <p>ADDITIONAL SERVICE WHEN REPLACING BCM25</p> <p style="padding-left: 20px;">Description25</p> <p style="padding-left: 20px;">Work Procedure25</p> <p>ID REGISTRATION PROCEDURE26</p> <p style="padding-left: 20px;">Description26</p> <p style="padding-left: 20px;">Work Procedure26</p> <p>CONFIGURATION (TIRE PRESSURE MONITORING SYSTEM)29</p> <p style="padding-left: 20px;">Work Procedure29</p> <p>DTC/CIRCUIT DIAGNOSIS31</p> <p>C1704, C1705, C1706, C1707 LOW TIRE PRESSURE31</p> <p style="padding-left: 20px;">DTC Logic31</p> <p style="padding-left: 20px;">Diagnosis Procedure31</p> <p>C1708, C1709, C1710, C1711 TRANSMITTER (NO DATA)33</p> <p style="padding-left: 20px;">DTC Logic33</p> <p style="padding-left: 20px;">Diagnosis Procedure33</p> <p>C1716, C1717, C1718, C1719 TRANSMITTER (PRESSURE DATA)36</p> <p style="padding-left: 20px;">DTC Logic36</p> <p style="padding-left: 20px;">Diagnosis Procedure36</p> <p>C1729 VEHICLE SPEED SIGNAL38</p> <p style="padding-left: 20px;">DTC Logic38</p> <p style="padding-left: 20px;">Diagnosis Procedure38</p>	<p>F G H I J K L M N O P</p>
--	--	--

C1730, C1731, C1732, C1733 FLAT TIRE	39	Diagnosis Procedure	55
DTC Logic	39		
Diagnosis Procedure	39		
C1734 BCM	41	LOW TIRE PRESSURE WARNING LAMP	
DTC Logic	41	BLINKS	56
Diagnosis Procedure	41	Description	56
		Diagnosis Procedure	56
C1735 IGNITION SIGNAL	43	LOW TIRE PRESSURE LOCATION INDICA-	
DTC Logic	43	TOR DOES NOT DISPLAY	57
Diagnosis Procedure	43	Description	57
		Diagnosis Procedure	57
C1765, C1766, C1767, C1768 TIRE PRES-		LOW TIRE PRESSURE LOCATION INDICA-	
SURE SENSOR	44	TOR CONTINUES DISPLAYING	58
DTC Logic	44	Description	58
Diagnosis Procedure	44	Diagnosis Procedure	58
C1769 CONFIGURATION SETTING	45	ID REGISTRATION CANNOT BE COMPLET-	
DTC Logic	45	ED	59
Diagnosis Procedure	45	Description	59
		Diagnosis Procedure	59
C1770, C1771, C1772, C1773 G SENSOR	46	EASY FILL TIRE ALERT DOES NOT ACTI-	
DTC Logic	46	VATE	60
Diagnosis Procedure	46	Description	60
		Diagnosis Procedure	60
U1000 CAN COMM CIRCUIT	47	NOISE, VIBRATION AND HARSHNESS	
Description	47	(NVH) TROUBLESHOOTING	62
DTC Logic	47	NVH Troubleshooting Chart	62
Diagnosis Procedure	47		
U1010 CONTROL UNIT (CAN)	48	PERIODIC MAINTENANCE	63
DTC Logic	48	WHEEL	63
Diagnosis Procedure	48	Inspection	63
LOW TIRE PRESSURE WARNING LAMP	49	WHEEL AND TIRE	64
Component Function Check	49	Adjustment	64
Diagnosis Procedure	49	REMOVAL AND INSTALLATION	67
POWER SUPPLY AND GROUND CIRCUIT	50	WHEEL AND TIRE	67
WITH INTELLIGENT KEY SYSTEM	50	Exploded View	67
WITH INTELLIGENT KEY SYSTEM : Diagnosis		Removal and Installation	67
Procedure	50	TIRE PRESSURE SENSOR	68
WITHOUT INTELLIGENT KEY SYSTEM	50	Exploded View	68
WITHOUT INTELLIGENT KEY SYSTEM : Diag-		Removal and Installation	69
nosis Procedure	50	Disposal	79
SYMPTOM DIAGNOSIS	52	REMOTE KEYLESS ENTRY RECEIVER	81
TPMS	52	Removal and Installation	81
Symptom Table	52	SERVICE DATA AND SPECIFICATIONS	
LOW TIRE PRESSURE WARNING LAMP		(SDS)	82
DOES NOT TURN ON	54	SERVICE DATA AND SPECIFICATIONS	
Description	54	(SDS)	82
Diagnosis Procedure	54	Wheel	82
LOW TIRE PRESSURE WARNING LAMP		Tire Air Pressure	82
STAYS ON	55		
Description	55		

PRECAUTIONS

< PRECAUTION >

PRECAUTION

PRECAUTIONS

Precaution for Supplemental Restraint System (SRS) "AIR BAG" and "SEAT BELT PRE-TENSIONER"

INFOID:000000012427668

The Supplemental Restraint System such as "AIR BAG" and "SEAT BELT PRE-TENSIONER", used along with a front seat belt, helps to reduce the risk or severity of injury to the driver and front passenger for certain types of collision. Information necessary to service the system safely is included in the SR and SB section of this Service Manual.

WARNING:

- To avoid rendering the SRS inoperative, which could increase the risk of personal injury or death in the event of a collision which would result in air bag inflation, all maintenance must be performed by an authorized NISSAN/INFINITI dealer.
- Improper maintenance, including incorrect removal and installation of the SRS, can lead to personal injury caused by unintentional activation of the system. For removal of Spiral Cable and Air Bag Module, see the SR section.
- Do not use electrical test equipment on any circuit related to the SRS unless instructed to in this Service Manual. SRS wiring harnesses can be identified by yellow and/or orange harnesses or harness connectors.

PRECAUTIONS WHEN USING POWER TOOLS (AIR OR ELECTRIC) AND HAMMERS

WARNING:

- When working near the Airbag Diagnosis Sensor Unit or other Airbag System sensors with the Ignition ON or engine running, DO NOT use air or electric power tools or strike near the sensor(s) with a hammer. Heavy vibration could activate the sensor(s) and deploy the air bag(s), possibly causing serious injury.
- When using air or electric power tools or hammers, always switch the Ignition OFF, disconnect the battery and wait at least three minutes before performing any service.

Service Notice and Precautions for TPMS

INFOID:000000012427669

WARNING:

Radio waves could adversely affect electric medical equipment. Those who use a pacemaker should contact the electric medical equipment manufacturer for the possible influences before use.

- Low tire pressure warning lamp blinks for 1 minute, then turns ON when occurring any malfunction except low tire pressure. Erase the self-diagnosis memories for Tire Pressure Monitoring System (TPMS), or register the ID to turn low tire pressure warning lamp OFF. For ID registration, refer to [WT-24, "Work Flow"](#).
- ID registration is required when replacing or rotating wheels, replacing tire pressure sensor or low tire pressure warning control unit. Refer to [WT-26, "Work Procedure"](#).
- Replace grommet seal, valve core and valve cap of tire pressure sensor in TPMS, when replacing each tire by reaching the wear limit. Refer to [WT-69, "Removal and Installation"](#).
- Because the tire pressure sensor conforms to North America radio law, the following items must be observed.
 - The sensor may be used only in North America.
 - It may not be used in any method other than the specified method.
 - It must not be disassembled or modified.

Service Notice and Precautions for Road Wheel

INFOID:000000012427670

- Genuine NISSAN aluminum wheel is designed for each type of vehicle. Use it on the specified vehicle only.
- Use Genuine NISSAN parts for the wheels, valve caps and wheel nuts.
- Always balance the wheels prior to using them. For the balance weights, use Genuine NISSAN aluminum wheel weights.
- Use caution when handling the aluminum wheels, because they can be easily scratched. When removing dirt, do not use any abrasives, a wire brush, or other items that may scratch the coating. Use a neutral detergent if a detergent is needed.
- After driving on roads scattered with anti-icing salts, wash off the wheels completely.
- When installing wheels onto the vehicle, always wipe off any dirt or foreign substances to prevent them from being trapped between the contact surfaces of wheel.

PRECAUTIONS

< PRECAUTION >

- Do not apply oil to nut and bolt threads.
- When tightening the valve cap there is a risk of damaging the valve cap if a tool is used. Tighten by hand.

PREPARATION

< PREPARATION >



PREPARATION

PREPARATION

Special Service Tool

INFOID:0000000012427671

The actual shape of the tools may differ from those illustrated here.

Tool number (TechMate No.) Tool name	Description
<p>— (J-50190) Signal Tech II</p>  <p>ALEIA0131ZZ</p>	<ul style="list-style-type: none"> • Activate and display TPMS transmitter IDs • Display tire pressure reported by the TPMS transmitter • Read TPMS DTCs • Register TPMS transmitter IDs • Test remote keyless entry keyfob relative signal strength • Check Intelligent Key relative signal strength • Confirm vehicle Intelligent Key antenna signal strength • Compatible with future sensors • Equipped with a display
<p>KV48105501 (J-45295-A) Transmitter activation tool</p>  <p>ALEIA0183ZZ</p>	<ul style="list-style-type: none"> • Activate TPMS transmitter IDs • Compatible with future sensors • Equipped with a display (KV48105501 only)

Commercial Service Tool

INFOID:0000000012427672

Tool name	Description
<p>Power tool</p>  <p>PIIB1407E</p>	<p>Loosening nuts, screws and bolts</p>

A
B
C
D
WT
F
G
H
I
J
K
L
M
N
O
P

COMPONENT PARTS

< SYSTEM DESCRIPTION >

SYSTEM DESCRIPTION

COMPONENT PARTS

Component Parts Location

INFOID:000000012427673

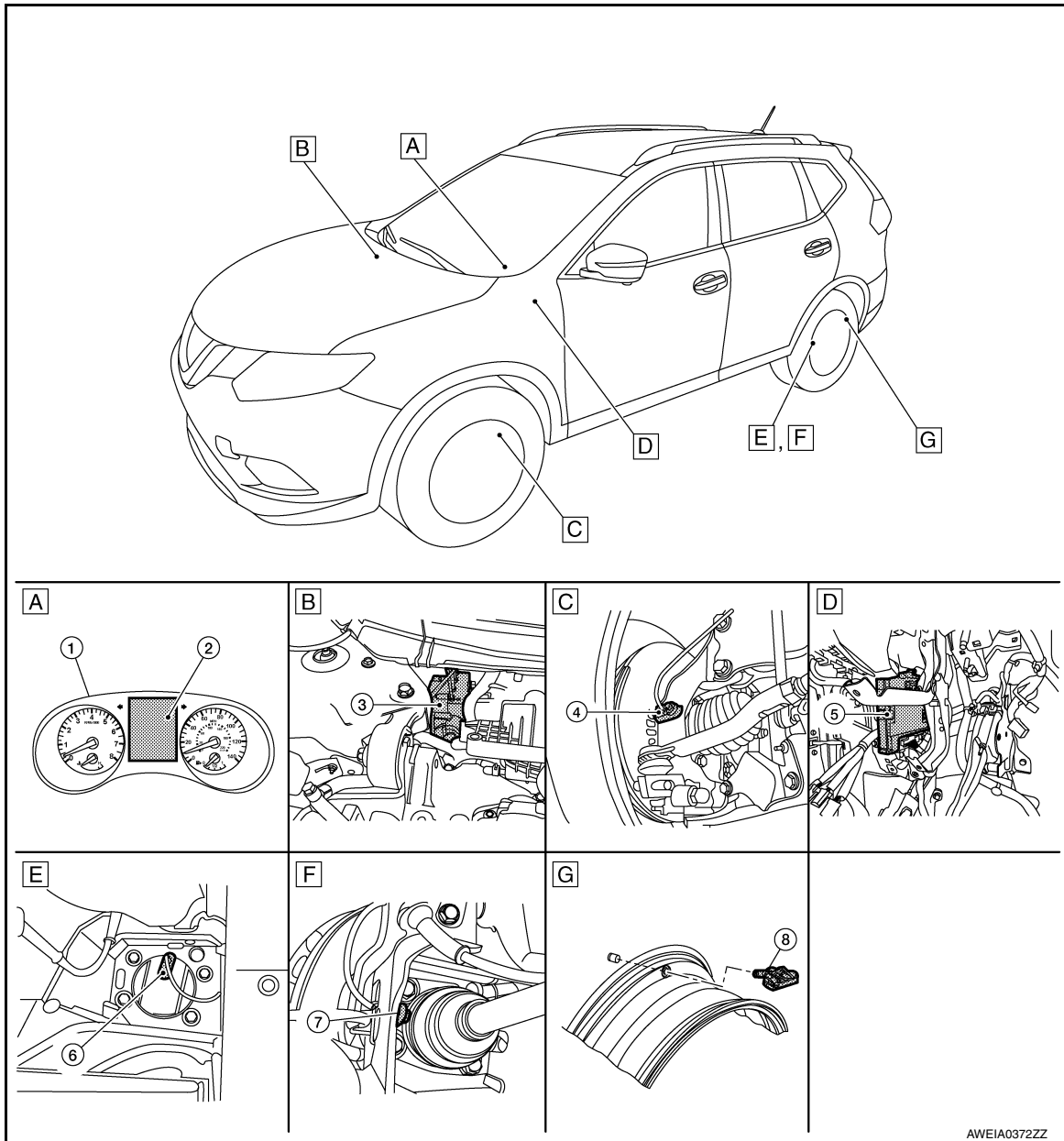

- | | | |
|---------------------------------|--|--|
| A. Combination meter | B. Engine room (RH) | C. Left front wheel assembly |
| D. Behind instrument panel (LH) | E. Left rear wheel assembly (FWD models) | F. Left rear wheel assembly (AWD models) |
| G. Wheel | | |

No.	Component parts	Function
1.	Combination meter	The combination meter receives tire pressure status from the BCM via CAN communication. The combination meter will display the low tire pressure warning lamp when a low tire pressure or system malfunction is detected by the BCM.
2.	Information display (in combination meter)	Refer to WT-7, "Information Display" .

COMPONENT PARTS

< SYSTEM DESCRIPTION >

No.	Component parts	Function
3.	ABS actuator and electric unit (control unit)	Mainly transmits the following signals to BCM via CAN communication: • Wheel sensor signal (ABS)
4.	Front wheel sensor LH (RH similar)	Refer to BRC-11, "Wheel Sensor and Sensor Rotor" .
5.	BCM	Refer to WT-7, "BCM" .
6.	Rear wheel sensor LH [FWD models (RH similar)]	Refer to BRC-11, "Wheel Sensor and Sensor Rotor" .
7.	Rear wheel sensor LH [AWD models (RH similar)]	Refer to BRC-11, "Wheel Sensor and Sensor Rotor" .
8.	Tire pressure sensor	Refer to WT-8, "Tire Pressure Sensor" .

BCM

INFOID:000000012427674

- Tire pressure receiver is integrated in BCM.
- The tire pressure receiver receives the tire pressure signal transmitted by the tire pressure sensor in each wheel.
- The BCM reads the tire pressure signal received by tire pressure receiver, and controls the low tire pressure warning lamp operations. It also has a judgment function to detect a system malfunction.

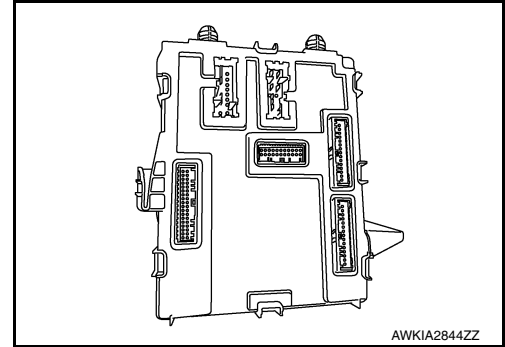

Information Display

INFOID:000000012427675

A low tire pressure warning or flat tire warning is shown on the vehicle information display when they are transmitted from the BCM to combination meter via CAN communication.

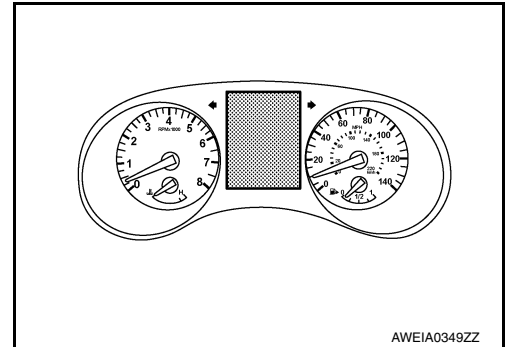

Condition		Vehicle information display
Ignition switch OFF		Not indicated
Ignition switch ON	Low tire pressure warning lamp remains ON after blinking for one minute. Tire Pressure Monitoring System (TPMS) malfunction.	Not indicated
Ignition switch ON	Low tire pressure warning lamp remains ON (low tire pressure).	Indicated
Ignition switch ON	Flat tire warning.	Indicated

COMPONENT PARTS

< SYSTEM DESCRIPTION >

Tire Pressure Sensor

INFOID:000000012427676

The tire pressure sensor (1) integrated with the valve is installed in each wheel (2), and transmits the detected tire pressure and temperature signal in the form of the radio wave. The radio signal is received by the BCM (tire pressure receiver).

← : Outside

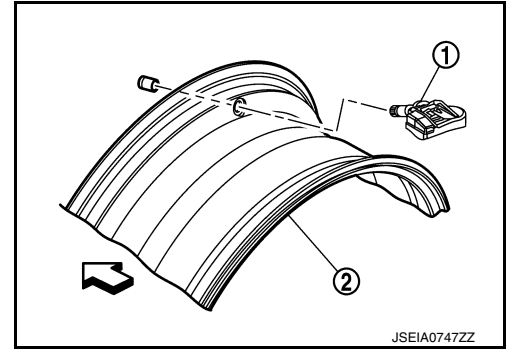

SYSTEM

< SYSTEM DESCRIPTION >

SYSTEM

System Description

INFOID:000000012427677

- During driving, the TPMS (Tire Pressure Monitoring System) receives the signal transmitted from tire pressure sensor installed in each wheel. The BCM of this system has pressure judgment and trouble diagnosis functions. When the TPMS (Tire Pressure Monitoring System) detects low inflation pressure or another unusual symptom, the low tire pressure warning lamp in the combination meter comes on.
- Tire pressure varies as per the change in tire temperature. Therefore, warning tire pressure value is varied as per the change in tire temperature.
- If the tire pressure is less than the warning tire pressure value, the low tire pressure warning lamp illuminates.

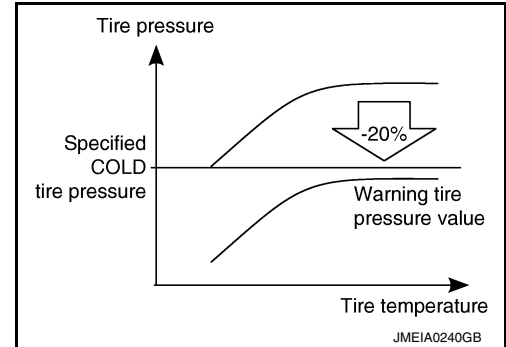

- Location of wheel is specified due to the synchronism of wheel sensor position and tire pressure sensor position.
- Activates the TPMS (Tire Pressure Monitoring System) when the vehicle speed is 40 km/h (25 MPH) or more.
- The tire pressure monitoring system (TPMS) has Easy Fill Tire alert function to aid in tire inflation. Refer to [WT-11, "Easy Fill Tire Alert Function"](#).

SYSTEM DIAGRAM

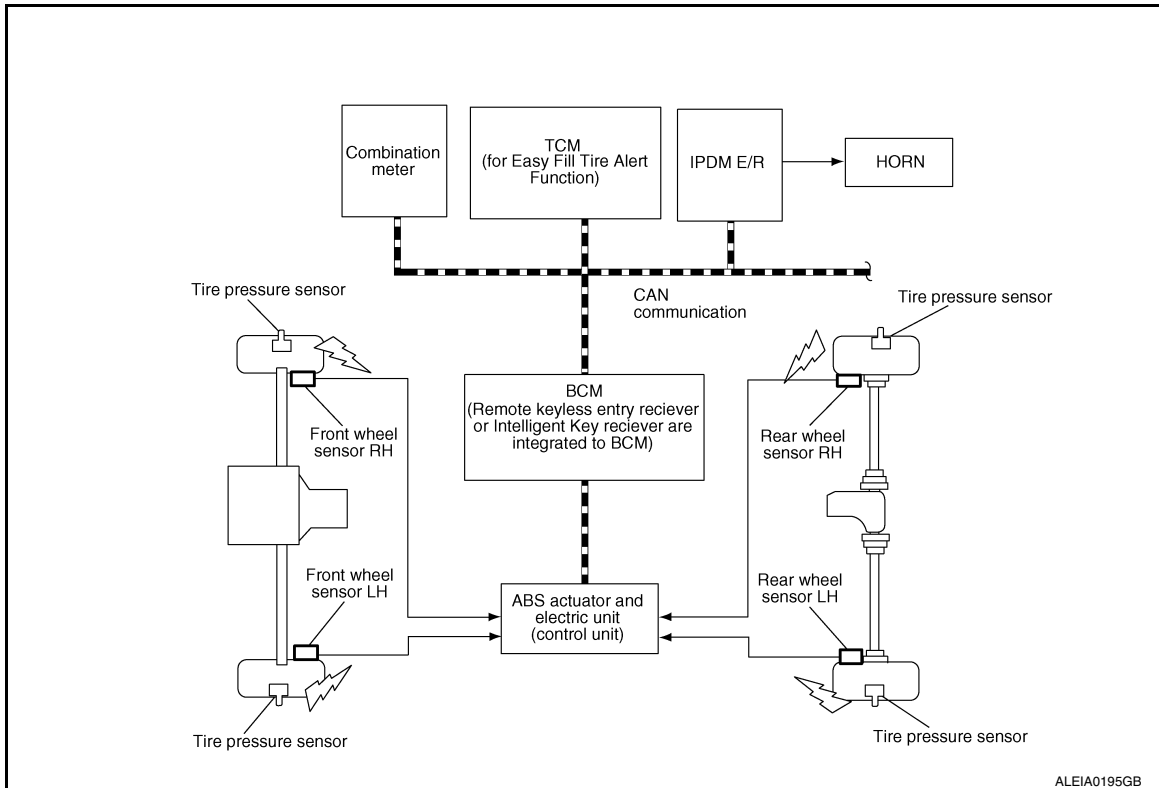

INPUT/OUTPUT SIGNAL

Major signal transmission between each unit via communication lines is shown in the following table.

SYSTEM

< SYSTEM DESCRIPTION >

Component parts	Signal item
BCM	<p>Mainly transmits the following signals to combination meter via CAN communication.</p> <ul style="list-style-type: none"> • Low tire pressure warning lamp signal • Low tire pressure wheel location signal • TPMS malfunction warning lamp signal <p>Mainly receives the following signal from ABS actuator and electric unit (control unit) via CAN communication.</p> <ul style="list-style-type: none"> • Vehicle speed signal (ABS)
Combination meter	<p>Mainly receives the following signals from BCM via CAN communication.</p> <ul style="list-style-type: none"> • Low tire pressure warning lamp signal • Low tire pressure wheel location signal • TPMS malfunction warning lamp signal
ABS actuator and electric unit (control unit)	<p>Mainly transmits the following signal to BCM via CAN communication:</p> <ul style="list-style-type: none"> • Vehicle speed signal (ABS)
TCM	<p>Mainly transmits the following signal to BCM via CAN communication:</p> <ul style="list-style-type: none"> • Shift position signal (P range signal)
IPDM E/R	<p>Mainly receives the following signal from BCM via CAN communication:</p> <ul style="list-style-type: none"> • Horn reminder signal

LOW TIRE PRESSURE WARNING LAMP INDICATION CONDITION

Uses CAN communication from the BCM to illuminate the low tire pressure warning lamp on the combination meter.

Name	Design	Layout
Low tire pressure warning lamp		Refer to MWI-7, "METER SYSTEM : Design" .

Condition	Low tire pressure warning lamp
Ignition switch OFF	OFF
Ignition switch ON (System normal)	Warning lamp turns on for 1 second, then turns off.
Low tire pressure	ON
Configuration not performed in tire pressure monitoring system	Warning lamp blinks 1 min., then turns on.
Tire pressure sensor ID not registered in BCM	
Tire pressure monitoring system malfunction (Other diagnostic item)	

LOW TIRE PRESSURE LOCATION INDICATOR

The low tire pressure location indicator is displayed in the information display of combination meter with the low tire pressure warning lamp and warning message under the following conditions:

- Tire pressure is low.
- Tire goes flat.

SYSTEM

< SYSTEM DESCRIPTION >

Design	Message	A
 <p style="text-align: right; font-size: small;">JMEIA0247ZZ</p>	Tire Pressure Low Add Air	B C D

TIRE PRESSURE DISPLAY

The adoption of this function allows tire pressure indication on the information display installed to the combination meter.

WT

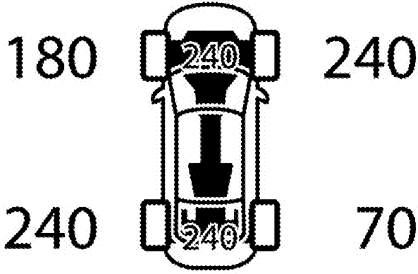
Design	Description	F
 <p style="text-align: right; font-size: small;">JMEIA0248ZZ</p>	<ul style="list-style-type: none"> • Tire pressure of each tire is displayed at side of each tire. • Setting tire pressure of front and rear tires are displayed between front/rear tires. 	G H I

HAZARD WARNING LAMP INDICATION CONDITION

The hazard warning lamp blinks under the following conditions:

- When ID registration is completed. Refer to [WT-26. "Work Procedure"](#).
- During the use of the Easy Fill Tire Alert function.

HORN CONTROL CONDITION

During the use of Easy Fill Tire Alert function.

Easy Fill Tire Alert Function

INFOID:000000012427678

- This function operates only when the select lever position is in P-range with the ignition switch ON.

NOTE:

The Easy Fill tire alert function is recommended to use with the ignition switch ON.

NOTE:

When beginning tire inflation, it takes a few seconds for the Easy fill tire alert to function. If there is no response for approximately 15 seconds or more, cancel the Easy fill tire alert function and move the vehicle approximately 1 m (3.2 ft) backward or forward to try again.

- The Easy fill tire alert function operates only when the select lever position is in P-range with the ignition switch ON.
- This function informs the driver with a visual and audible indication that the recommended COLD tire pressure has been reached.

SYSTEM

< SYSTEM DESCRIPTION >

- The hazard warning lamps blink when the recommended COLD tire pressure has been reached. After the recommended COLD tire pressure has been reached, the horn sounds once and the hazard warning lamps stop blinking.
- If the tire pressure value is equal to or greater than 30 kPa (0.31 kg/cm², 4 psi) more than the recommended COLD tire pressure, the hazard warning lamps flash and horn sounds three times.
- To return the tire to the recommended COLD tire pressure, deflate the tire until the horn sounds once and the hazard warning lamps stop blinking.

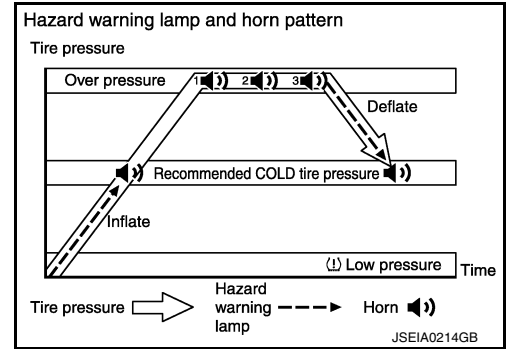

DIAGNOSIS SYSTEM (TIRE PRESSURE MONITORING SYSTEM)

< SYSTEM DESCRIPTION >

DIAGNOSIS SYSTEM (TIRE PRESSURE MONITORING SYSTEM)

CONSULT Function

INFOID:0000000012427679

APPLICATION ITEM

CONSULT performs the following functions via CAN communication with BCM.

Diagnosis mode	Function Description
Self Diagnostic Result	<ul style="list-style-type: none">Retrieve DTC from BCM and display diagnostic items.Self-diagnostic results and freeze frame data can be read and erased quickly.
Data Monitor	Monitor the input/output signal of the BCM in real time.
Work support	This mode enables a technician to adjust some devices faster and more accurately.
Active Test	Send the drive signal from CONSULT to the actuator. The operation check can be performed.
ECU identification	Parts number of BCM can be read.
Configuration	<ul style="list-style-type: none">Read and save the vehicle specification (TYPE ID).Write the vehicle specification (TYPE ID) when replacing BCM.

ACTIVE TEST

Test Item	Description
ID REGIST WARNING	This test is able to check ID regist warning chime operation [On/Off].
WARNING LAMP	This test is able to check tire pressure warning lamp operation [On/Off].
FLASHER	This test is able to check turn signal lamp operation [On/Off].
HORN	This test is able to check horn operation [On/Off].

ECU IDENTIFICATION

BCM part number can be read.

SELF DIAGNOSTIC RESULT

NOTE:

Before performing Self Diagnostic Result, be sure to register the tire pressure sensor ID or the actual malfunction may be different from that displayed on CONSULT.

Refer to following: [WT-16, "DTC Index"](#).

FREEZE FRAME DATA (FFD)

The following vehicle status is recorded when DTC is detected and is displayed on CONSULT.

Item name	Display item
WARNING AIR PRESSURE FL	Warning air pressure front left
WARNING AIR PRESSURE FR	Warning air pressure front right
WARNING AIR PRESSURE RR	Warning air pressure rear right
WARNING AIR PRESSURE RL	Warning air pressure rear left
AIR PRESS FL	Air pressure front left
AIR PRESS FR	Air pressure front right
AIR PRESS RR	Air pressure rear right
AIR PRESS RL	Air pressure rear left

DATA MONITOR

NOTE:

The following table includes information (items) inapplicable to this vehicle. For information (items) applicable to this vehicle, refer to CONSULT display items.

DIAGNOSIS SYSTEM (TIRE PRESSURE MONITORING SYSTEM)

< SYSTEM DESCRIPTION >

Monitor Item (Unit)	Description
AIR PRESS FL (kPa, kgf/cm ² or Psi)	Indicates air pressure of front left tire.
AIR PRESS FR (kPa, kgf/cm ² or Psi)	Indicates air pressure of front right tire.
AIR PRESS RR (kPa, kgf/cm ² or Psi)	Indicates air pressure of rear right tire.
AIR PRESS RL (kPa, kgf/cm ² or Psi)	Indicates air pressure of rear left tire.
WARNING AIR PRESSURE FL (kPa, kgf/cm ² or Psi)	Indicates warning air pressure front left tire.
WARNING AIR PRESSURE FR (kPa, kgf/cm ² or Psi)	Indicates warning air pressure front right tire.
WARNING AIR PRESSURE RR (kPa, kgf/cm ² or Psi)	Indicates warning air pressure rear right tire.
WARNING AIR PRESSURE RL (kPa, kgf/cm ² or Psi)	Indicates warning air pressure rear left tire.
VHCL SPEED SE (km/h)	Vehicle speed from the ABS actuator and electric unit (control unit) is displayed.
LOW TIRE PRESSURE W/L (Off/On)	Indicates condition of low tire pressure warning lamp in combination meter.
BUZZER 2 (Off/On)	Indicates condition of buzzer in combination meter.
HORN (Off/On)	Indicates condition of horn.
HAZARD (Off/On)	Indicates condition of hazard.

WORK SUPPORT

Support Item	Description
ID REGIST	Refer to WT-26, "Description" .

TIRE PRESSURE MONITORING SYSTEM

< ECU DIAGNOSIS INFORMATION >

ECU DIAGNOSIS INFORMATION

TIRE PRESSURE MONITORING SYSTEM

Reference Value

INFOID:0000000012427680

VALUES ON THE DIAGNOSIS TOOL

CAUTION:

The reference values in the table below come from the control unit calculation data. The normal values may in some cases be displayed even though the power circuit (harness) is open or shorted.

NOTE:

The following table includes information (items) inapplicable to this vehicle. For information (items) applicable to this vehicle, refer to CONSULT display items.

Monitor item	Data monitor	
	Condition	Reference values for normal operation
AIR PRESS FL	<ul style="list-style-type: none"> Drive at a speed of 40 km/h (25 MPH) or more then drive normally for 10 minutes. Turn the ignition switch ON and use the activation tool to transmit the registration signal. 	Tire pressure (kPa), (kgf/cm ²) or (Psi)
AIR PRESS FR		
AIR PRESS RR		
AIR PRESS RL		
WARNING AIR PRESSURE FL	Ignition switch ON	Indicates warning air pressure front left tire (kPa), (kgf/cm ²) or (Psi)
WARNING AIR PRESSURE FR	Ignition switch ON	Indicates warning air pressure front right tire (kPa), (kgf/cm ²) or (Psi)
WARNING AIR PRESSURE RR	Ignition switch ON	Indicates warning air pressure rear right tire (kPa), (kgf/cm ²) or (Psi)
WARNING AIR PRESSURE RL	Ignition switch ON	Indicates warning air pressure rear left tire (kPa), (kgf/cm ²) or (Psi)
VHCL SPEED SE	Drive the vehicle.	Vehicle speed (km/h) or (MPH)
LOW TIRE PRESSURE W/L	Ignition switch ON	Low tire pressure warning lamp ON: On Low tire pressure warning lamp OFF: Off
BUZZER 2	Ignition switch ON	Combination meter buzzer ON: On Combination meter buzzer OFF: Off
HORN	Ignition switch ON	Horn ON: On Horn OFF: Off
HAZARD	Ignition switch ON	Hazard lamp ON: On Hazard lamp OFF: Off

TERMINAL LAYOUT

Refer to [BCS-29. "Reference Value"](#) (with Intelligent Key system) or [BCS-97. "Reference Value"](#) (without Intelligent Key system).

PHYSICAL VALUES

Refer to [BCS-29. "Reference Value"](#) (with Intelligent Key system) or [BCS-97. "Reference Value"](#) (without Intelligent Key system).

DTC Inspection Priority Chart

INFOID:0000000012427681

If some DTCs are displayed at the same time, perform inspections one by one based on the following priority chart.

Priority	Detected items (DTC)
1	C1769 CONFIG SETTING
2	C1734 CONTROL UNIT

TIRE PRESSURE MONITORING SYSTEM

< ECU DIAGNOSIS INFORMATION >

Priority	Detected items (DTC)
3	C1735 IGNITION SIGNAL
4	<ul style="list-style-type: none"> • U1000 CAN COMM CIRCUIT • U1010 CONTROL UNIT (CAN)
5	C1729 VHCL SPEED SIG ERR
6	<ul style="list-style-type: none"> • C1765 WHEEL TOP DATA FL • C1766 WHEEL TOP DATA FR • C1767 WHEEL TOP DATA RL • C1768 WHEEL TOP DATA RR
7	<ul style="list-style-type: none"> • C1716 [PRESSDATA ERR] FL • C1717 [PRESSDATA ERR] FR • C1718 [PRESSDATA ERR] RR • C1719 [PRESSDATA ERR] RL
8	<ul style="list-style-type: none"> • C1708 [NO DATA] FL • C1709 [NO DATA] FR • C1710 [NO DATA] RR • C1711 [NO DATA] RL
9	<ul style="list-style-type: none"> • C1704 LOW PRESSURE FL • C1705 LOW PRESSURE FR • C1706 LOW PRESSURE RR • C1707 LOW PRESSURE RL
10	<ul style="list-style-type: none"> • C1730 FLAT TIRE FL • C1731 FLAT TIRE FR • C1732 FLAT TIRE RR • C1733 FLAT TIRE RL
11	<ul style="list-style-type: none"> • C1770 G SENSOR FL • C1771 G SENSOR FR • C1772 G SENSOR RL • C1773 G SENSOR RR

DTC Index

INFOID:000000012427682

DTC	Items (CONSULT screen terms)	Low tire pressure warning lamp	Reference
C1704	LOW PRESSURE FL	ON	WT-31, "DTC Logic"
C1705	LOW PRESSURE FR		
C1706	LOW PRESSURE RR		
C1707	LOW PRESSURE RL		
C1708	[NO DATA] FL	The low tire pressure warning lamp repeats blinking at 0.5-second intervals for 1 minute, and then stays illuminated.	WT-33, "DTC Logic"
C1709	[NO DATA] FR		
C1710	[NO DATA] RR		
C1711	[NO DATA] RL		
C1716	[PRESSDATA ERR] FL	The low tire pressure warning lamp repeats blinking at 0.5-second intervals for 1 minute, and then stays illuminated.	WT-36, "DTC Logic"
C1717	[PRESSDATA ERR] FR		
C1718	[PRESSDATA ERR] RR		
C1719	[PRESSDATA ERR] RL		
C1729	VHCL SPEED SIG ERR	The low tire pressure warning lamp repeats blinking at 0.5-second intervals for 1 minute, and then stays illuminated.	WT-38, "DTC Logic"

TIRE PRESSURE MONITORING SYSTEM

< ECU DIAGNOSIS INFORMATION >

DTC	Items (CONSULT screen terms)	Low tire pressure warning lamp	Reference	
C1730	FLAT TIRE FL	ON	WT-39, "DTC Logic"	A
C1731	FLAT TIRE FR			B
C1732	FLAT TIRE RR			
C1733	FLAT TIRE RL			
C1734	CONTROL UNIT	The low tire pressure warning lamp repeats blinking at 0.5-second intervals for 1 minute, and then stays illuminated.	WT-41, "DTC Logic"	C
C1735	IGNITION SIGNAL	The low tire pressure warning lamp repeats blinking at 0.5-second intervals for 1 minute, and then stays illuminated.	WT-43, "DTC Logic"	D
C1765	WHEEL TOP DATA FL	The low tire pressure warning lamp repeats blinking at 0.5-second intervals for 1 minute, and then stays illuminated.	WT-44, "DTC Logic"	WT
C1766	WHEEL TOP DATA FR			
C1767	WHEEL TOP DATA RL			
C1768	WHEEL TOP DATA RR			
C1769	CONFIG SETTING	The low tire pressure warning lamp repeats blinking at 0.5-second intervals for 1 minute, and then stays illuminated.	WT-45, "DTC Logic"	G
C1770	G SENSOR FL	OFF	WT-46, "DTC Logic"	H
C1771	G SENSOR FR			
C1772	G SENSOR RL			
C1773	G SENSOR RR			
U1000	CAN COMM CIRCUIT	The low tire pressure warning lamp repeats blinking at 0.5-second intervals for 1 minute, and then stays illuminated.	WT-47, "Description"	J
U1010	CONTROL UNIT (CAN)	The low tire pressure warning lamp repeats blinking at 0.5-second intervals for 1 minute, and then stays illuminated.	WT-48, "DTC Logic"	K

NOTE:

If some DTCs are displayed at the same time, refer to [WT-15, "DTC Inspection Priority Chart"](#).

BCM

< ECU DIAGNOSIS INFORMATION >

BCM

List of ECU Reference

INFOID:000000012427683

ECU	Reference
BCM (with Intelligent Key system)	BCS-29. "Reference Value"
	BCS-47. "Fail Safe"
	BCS-47. "DTC Inspection Priority Chart"
	BCS-48. "DTC Index"
BCM (without Intelligent Key system)	BCS-97. "Reference Value"
	BCS-108. "Fail Safe"
	BCS-109. "DTC Inspection Priority Chart"
	BCS-109. "DTC Index"

TIRE PRESSURE MONITORING SYSTEM

< WIRING DIAGRAM >

WIRING DIAGRAM

TIRE PRESSURE MONITORING SYSTEM

Wiring Diagram

INFOID:000000012427684

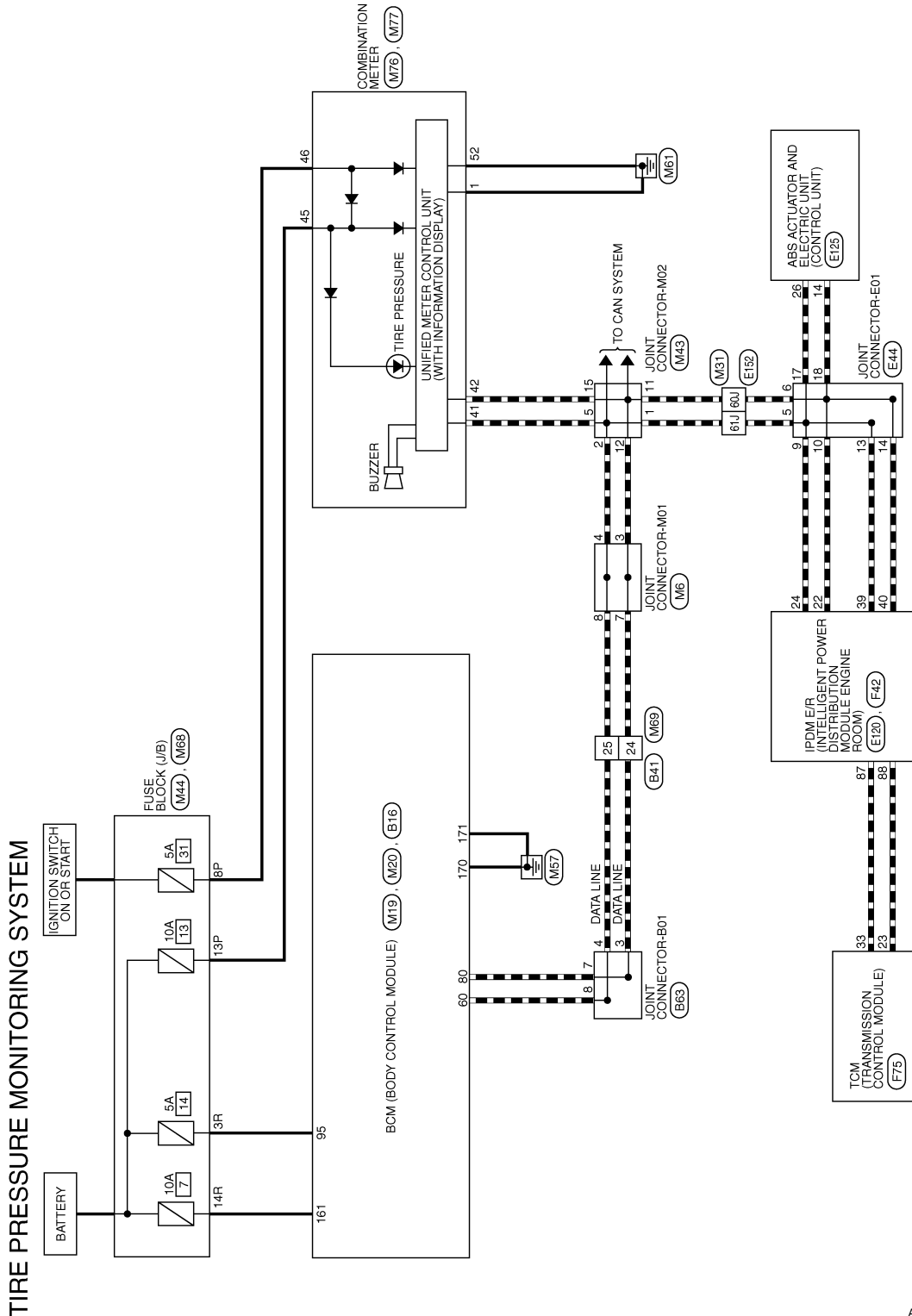

AAEWA0087GB

A
B
C
D
WT
F
G
H
I
J
K
L
M
N
O
P

TIRE PRESSURE MONITORING SYSTEM

< WIRING DIAGRAM >

TIRE PRESSURE MONITORING SYSTEM CONNECTORS

Connector No.	M6
Connector Name	JOINT CONNECTOR-M01
Connector Color	GRAY

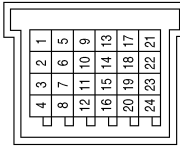

Terminal No.	Color of Wire	Signal Name
3	P	-
4	L	-
7	P	-
8	L	-

Connector No.	M19
Connector Name	BCM (BODY CONTROL MODULE)
Connector Color	BLACK

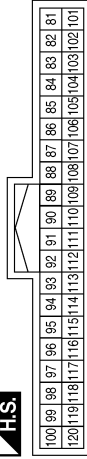

Terminal No.	Color of Wire	Signal Name
95	V	I SHORTING PIN

Connector No.	M20
Connector Name	BCM (BODY CONTROL MODULE)
Connector Color	BROWN



Terminal No.	Color of Wire	Signal Name
161	W	I PWR ECU
170	B	I GND1
171	B	I GND2

Connector No.	M31
Connector Name	WIRE TO WIRE
Connector Color	WHITE

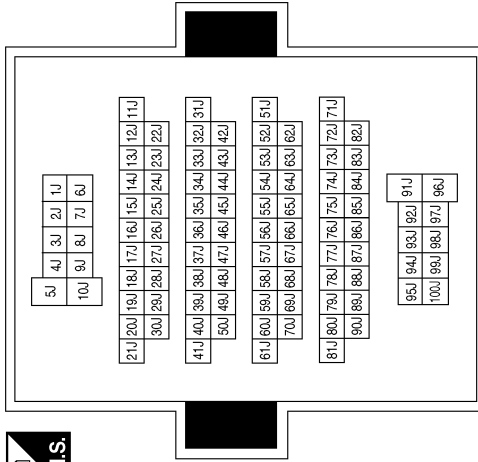

Terminal No.	Color of Wire	Signal Name
60J	P	-
61J	L	-

Connector No.	M43
Connector Name	JOINT CONNECTOR-M02
Connector Color	BLUE

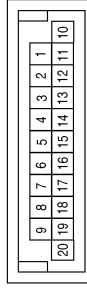

Terminal No.	Color of Wire	Signal Name
1	L	-
2	L	-
5	L	-
11	P	-
12	P	-
15	P	-

AAEIA0178GB

TIRE PRESSURE MONITORING SYSTEM

< WIRING DIAGRAM >

Connector No.	M69
Connector Name	WIRE TO WIRE
Connector Color	WHITE

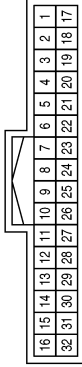

Terminal No.	Color of Wire	Signal Name
24	P	-
25	L	-

Connector No.	M68
Connector Name	FUSE BLOCK (J/B)
Connector Color	BROWN



Terminal No.	Color of Wire	Signal Name
3R	V	-
14R	W	-

Connector No.	M44
Connector Name	FUSE BLOCK (J/B)
Connector Color	WHITE



Terminal No.	Color of Wire	Signal Name
8P	LA/BR	-
13P	LA/G	-

Connector No.	E44
Connector Name	JOINT CONNECTOR-E01
Connector Color	WHITE

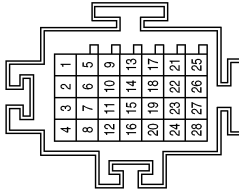

Connector No.	M77
Connector Name	COMBINATION METER
Connector Color	WHITE

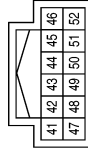

Terminal No.	Color of Wire	Signal Name
5	L	-
6	P	-
9	L	-
10	P	-
13	L	-
14	P	-
17	L	-
18	P	-

Connector No.	M76
Connector Name	COMBINATION METER
Connector Color	WHITE

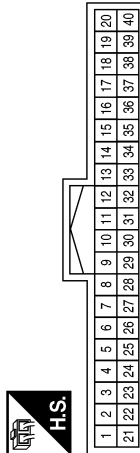

Terminal No.	Color of Wire	Signal Name
1	B	GND

AAEIA0123GB

A
B
C
D
WT
F
G
H
I
J
K
L
M
N
O
P

TIRE PRESSURE MONITORING SYSTEM

< WIRING DIAGRAM >

Connector No.	E120
Connector Name	IPDM E/R (INTELLIGENT POWER DISTRIBUTION MODULE ENGINE ROOM)
Connector Color	GRAY

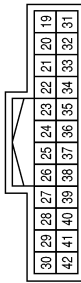

Terminal No.	Color of Wire	Signal Name
22	P	CAN-L
24	L	CAN-H
39	L	CAN-H
40	P	CAN-L

Connector No.	E125
Connector Name	ABS ACTUATOR AND ELECTRIC UNIT (CONTROL UNIT)
Connector Color	BLACK

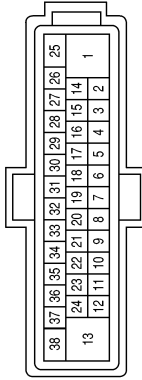

Terminal No.	Color of Wire	Signal Name
14	P	CAN-L
26	L	CAN-H

Connector No.	E152
Connector Name	WIRE TO WIRE
Connector Color	WHITE

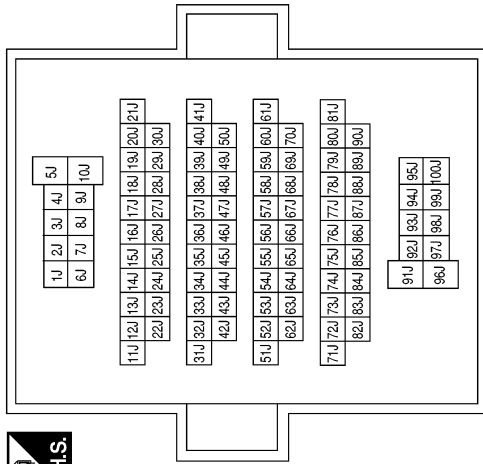

Terminal No.	Color of Wire	Signal Name
60J	P	-
61J	L	-

Connector No.	F42
Connector Name	IPDM E/R (INTELLIGENT POWER DISTRIBUTION MODULE ENGINE ROOM)
Connector Color	BLACK

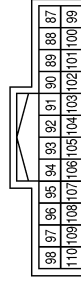

Terminal No.	Color of Wire	Signal Name
87	L	CAN-H
88	P	CAN-L

AAE1A0179GB

TIRE PRESSURE MONITORING SYSTEM

< WIRING DIAGRAM >

Connector No.	B41
Connector Name	WIRE TO WIRE
Connector Color	WHITE

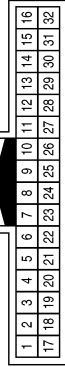

Terminal No.	Color of Wire	Signal Name
24	P	-
25	L	-

Connector No.	B16
Connector Name	BCM (BODY CONTROL MODULE)
Connector Color	GREEN

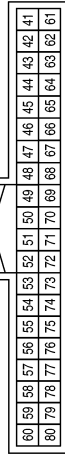

Terminal No.	Color of Wire	Signal Name
60	L	CAN-H
80	P	CAN-L

Connector No.	F75
Connector Name	TCM (TRANSMISSION CONTROL MODULE)
Connector Color	BLACK

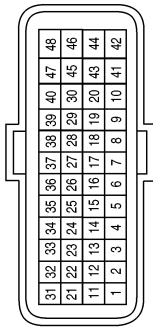

Terminal No.	Color of Wire	Signal Name
23	P	CAN-L
33	L	CAN-H

Connector No.	B63
Connector Name	JOINT CONNECTOR-B01
Connector Color	GRAY

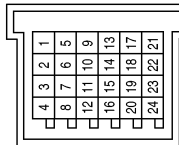

Terminal No.	Color of Wire	Signal Name
3	P	-
4	L	-
7	P	-
8	L	-

AAEIA0125GB

A
B
C
D
WT
F
G
H
I
J
K
L
M
N
O
P

DIAGNOSIS AND REPAIR WORK FLOW

< BASIC INSPECTION >

BASIC INSPECTION

DIAGNOSIS AND REPAIR WORK FLOW

Work Flow

INFOID:000000012427685

NOTE:

The Signal Tech II Tool [- (J-50190)] can be used to perform the following functions. Refer to the Signal Tech II User Guide for additional information.

- Activate and display TPMS sensor IDs
- Display tire pressure reported by the TPMS sensor
- Read TPMS DTCs
- Register TPMS sensor IDs

1. COLLECT INFORMATION FROM CUSTOMER

Get detailed information from the customer about the symptom (the condition and the environment when the incident/malfunction occurred).

>> GO TO 2.

2. TIRE PRESSURE INSPECTION

Check the tire pressure for all wheels. Refer to [WT-82, "Tire Air Pressure"](#).

Is the inspection result normal?

YES >> GO TO 3.

NO >> Repair or replace tire(s) or wheel(s).

3. CHECK LOW TIRE PRESSURE WARNING LAMP

Check that the low tire pressure warning lamp illuminates for approximately 1 second after the ignition switch is turned ON, then turns OFF.

Does the low tire pressure warning lamp turn OFF?

YES >> Inspection End.

NO >> GO TO 4.

4. PERFORM SELF DIAGNOSTIC RESULT

Perform "Self Diagnostic Result". Refer to [WT-13, "CONSULT Function"](#).

Are any DTCs displayed?

YES >> Refer to [WT-16, "DTC Index"](#). If two or more DTCs are displayed, refer to [WT-15, "DTC Inspection Priority Chart"](#).

NO >> GO TO 5.

5. PERFORM DIAGNOSIS APPLICABLE TO THE SYMPTOM

Perform diagnosis applicable to the symptom. Refer to [WT-52, "Symptom Table"](#).

>> GO TO 6.

6. FINAL CHECK

Perform "Self Diagnostic Result" again, and check that the malfunction is repaired. After checking, erase the self diagnosis memory. Refer to [WT-13, "CONSULT Function"](#).

>> Inspection End.

ADDITIONAL SERVICE WHEN REPLACING BCM

< BASIC INSPECTION >

ADDITIONAL SERVICE WHEN REPLACING BCM

Description

INFOID:000000012427686

When replacing BCM, configuration (BCM and TPMS) and then tire pressure sensor ID registration is required.

Work Procedure

INFOID:000000012427687

1.PERFORM CONFIGURATION (BCM)

Perform configuration BCM. Refer to [BCS-62. "CONFIGURATION \(BCM\) : Work Procedure"](#) (with Intelligent Key system) or [BCS-123. "CONFIGURATION \(BCM\) : Work Procedure"](#) (without Intelligent Key system).

>> GO TO 2.

2.PERFORM CONFIGURATION (TIRE PRESSURE MONITORING SYSTEM)

Perform configuration tire pressure monitoring system. Refer to [WT-29. "Work Procedure"](#).

>> GO TO 3.

3.PERFORM TIRE PRESSURE SENSOR ID REGISTRATION

Perform tire pressure sensor ID registration. Refer to [WT-26. "Work Procedure"](#).

>> Work End.

A
B
C
D
WT
F
G
H
I
J
K
L
M
N
O
P

ID REGISTRATION PROCEDURE

< BASIC INSPECTION >

ID REGISTRATION PROCEDURE

Description

INFOID:000000012427688

This procedure must be performed after replacement of a tire pressure sensor or BCM.

Work Procedure

INFOID:000000012427689

TPMS ID registration can be performed using one of the following procedures:

- Transmitter Activation tool [KV48105501 (J-45295-A)] using CONSULT (preferred method)
- Signal Tech II tool [- (J-50190)] using CONSULT (preferred method)
- Signal Tech II tool [- (J-50190)] without CONSULT
- CONSULT only

TPMS REGISTRATION WITH TRANSMITTER ACTIVATION TOOL [KV48105501 (J-45295-A)]

With CONSULT

1. Turn the ignition switch ON.
2. Using CONSULT, select "Work support" in "AIR PRESSURE MONITOR". Then, select "ID REGIST."
3. Select "Start" on "ID REGIST" screen.
4. Hold the transmitter activation tool [KV48105501 (J-45295-A)] (1) against the side of the left front tire, near the valve stem.
5. With the tool held at a 0 to 15 degree angle to the tire, press and hold the transmitter activation tool button until the indicator lamp turns OFF (approximately 5 seconds).
6. Repeat steps 4 and 5 for the remaining tires in this order: right front, right rear and left rear.

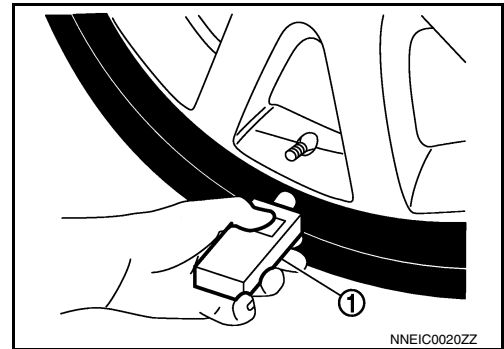

7. When ID registration is complete, check the following pattern at each wheel.

Sequence	ID registration position	Turn signal lamp	CONSULT
1	Front LH	2 blinks	"Yet (red)" ↓ "Done (green)"
2	Front RH		
3	Rear RH		
4	Rear LH		

8. After the ID registration procedure for all wheels is complete, press "End" on the CONSULT to finish ID registration.
9. Test drive the vehicle to ensure that the TPMS lamp is OFF and no warning messages are present.

TPMS REGISTRATION WITH SIGNAL TECH II TOOL [- (J-50190)]

NOTE:

The Signal Tech II must be updated with the newest software version in order to perform the below procedures. The Signal Tech II software updates can only be downloaded from a CONSULT unit with ASIST. Other versions of ASIST will not show the updates.

With CONSULT

1. Adjust the tire pressure for all tires to the recommended value. Refer to [WT-82. "Tire Air Pressure"](#).
2. Turn the ignition switch ON.
3. Using CONSULT, select "Work support" in "AIR PRESSURE MONITOR". Then, select "ID REGIST."
4. Select "Start" on "ID REGIST" screen.
5. Turn on the Signal Tech II tool [- (J-50190)].

ID REGISTRATION PROCEDURE

< BASIC INSPECTION >

6. Hold the Signal Tech II against the side of the left front tire, near the valve stem.
7. With the tool held at a 0 to 15 degree angle to the tire, select "Activate Sensor" from the main menu, then press and release the "OK" button to activate the sensor. Once the sensor is activated, the vehicle parking lamps will flash and the sensor ID will appear on the CONSULT screen.
8. Repeat steps 6 and 7 for the remaining tires in this order: right front, right rear and left rear.
9. When ID registration is complete, check the following pattern at each wheel.

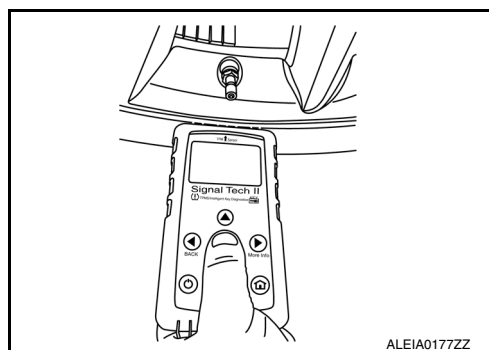

Sequence	ID registration position	Turn signal lamp	CONSULT
1	Front LH	2 blinks	"Yet (red)" ↓ "Done (green)"
2	Front RH		
3	Rear RH		
4	Rear LH		

10. Once all sensors have been activated, select "End" on the CONSULT to finish ID registration.
11. Test drive the vehicle to ensure that the TPMS lamp is OFF and no warning messages are present.

⊗ Without CONSULT

1. Adjust the tire pressure for all tires to the recommended value. Refer to [WT-82, "Tire Air Pressure"](#).
2. Turn on the Signal Tech II tool [- (J-50190)] and select "TPMS Check" from the main menu.
3. Select vehicle model and year.
4. When prompted, hold the Signal Tech II against the side of the left front tire, near the valve stem.
5. With the tool held at a 0 to 15 degree angle to the tire, press and release the "OK" button to activate the sensor. Once the sensor is activated, the tool will sound a tone and the tire pressure will be displayed.
6. Repeat steps 4 and 5 for the remaining tires in this order: right front, right rear and left rear.
7. When prompted, connect the tool to the data link connector. The tool will connect to the BCM, read the VIN, read sensor IDs and check for TPMS DTCs. Along with DTCs detected, one of the following will be displayed next to each wheel:
 - N/A - Not applicable because no ID found by the tool
 - OK - Wheel and sensor are in original position
 - NEW - New ID found compared to BCM
 - RT - Wheel has been rotated
 - Low Press - Low tire pressure
8. If no DTC is present or the repair has been completed, press the "OK" button to register the IDs and clear DTCs.
9. Test drive the vehicle to ensure that the TPMS lamp is OFF and no warning messages are present.
10. Print a Signal Tech II Audit Report for your records. Refer to the Signal Tech II User Guide for instructions.

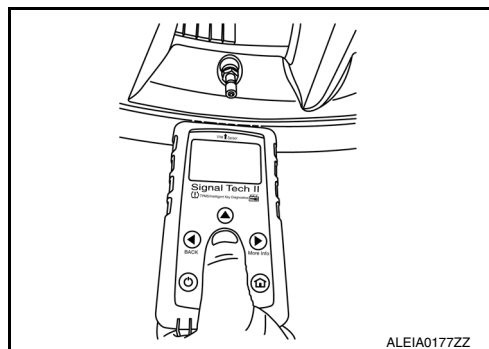

TPMS REGISTRATION WITH CONSULT ONLY

Ⓟ With CONSULT

1. Adjust the tire pressure for all wheels to match the list below.

Tire position	Tire pressure kPa (kg/cm ² , psi)
Front LH	240 (2.4, 35)
Front RH	220 (2.2, 32)
Rear RH	200 (2.0, 29)
Rear LH	180 (1.8, 26)

ID REGISTRATION PROCEDURE

< BASIC INSPECTION >

- Turn the ignition switch ON.
- Using CONSULT, select "Work support" in "AIR PRESSURE MONITOR". Then, select "ID REGIST."
- Select "Start" on "ID REGIST" screen.
- Drive the vehicle at a speed greater than 40 km/h (25 MPH) for 3 minutes or more.
- After ID registration for all wheels is complete, press "End" on the CONSULT to finish ID registration.

ID registration position	CONSULT
Front LH	"Yet (red)" ↓ "Done (green)"
Front RH	
Rear RH	
Rear LH	

- Adjust the tire pressures for all tires to the recommended value. Refer to [WT-82, "Tire Air Pressure"](#).
- Test drive the vehicle to ensure that the TPMS lamp is OFF and no warning messages are present.

CONFIGURATION (TIRE PRESSURE MONITORING SYSTEM)

< BASIC INSPECTION >

CONFIGURATION (TIRE PRESSURE MONITORING SYSTEM)

Work Procedure

INFOID:000000012427690

CAUTION:

- After configuration, perform the following:
 - Turn the ignition switch from OFF to ON and check that the low tire pressure warning lamp turns OFF after staying illuminated for approximately two seconds.
 - Perform tire pressure sensor ID registration. Refer to [WT-26, "Work Procedure"](#).
- If TPMS configuration is not completed, TPMS transmitter ID registration will not complete.

1. CHECKING ECU IDENTIFICATION NUMBER

CONSULT

1. Select "ECU Identification" of "BCM".
2. Write down ECU part number.

>> GO TO 2.

2. RE/PROGRAMMING, CONFIGURATION

CONSULT

1. Select "Re/programming, Configuration" from home screen.
2. Check box confirming the precautions have been read.
3. Select "Next".

Is "Manual Selection (Vehicle Name)" displayed?

- YES >> GO TO 3.
NO >> GO TO 4.

3. VEHICLE SELECTION

CONSULT

1. Select Vehicle Make, Vehicle Name, and correct model year.
2. Press "Select".

>> GO TO 4.

4. VEHICLE CONFIRMATION

CONSULT

1. Verify VIN or Chassis Number matches the vehicles VIN.
2. Select "Confirm".

>> GO TO 5.

5. INPUT VIN

1. Verify VIN number in dialog box matches vehicles VIN.
2. Select "Confirm".

>> GO TO 6.

6. SYSTEM SELECTION

CONSULT

Select "AIR PRESSURE MONITOR".

>> GO TO 7.

7. OPERATION SELECTION

1. Select "Manual Configuration"
2. Select the DATA PART NO. that matches the BCM part number written down in step 1.
3. Select "Next".

CONFIGURATION (TIRE PRESSURE MONITORING SYSTEM)

< BASIC INSPECTION >

>> GO TO 8.

8. WRITE CONFIGURATION

Ⓟ CONSULT

1. Confirm that the correct DATA PART NO. is listed.
2. Select "OK".

>> GO TO 9.

9. CHECKING LOW TIRE PRESSURE WARNING LAMP

1. Turn the ignition switch OFF.
2. Turn the ignition switch ON and check that the low tire pressure warning lamp turns OFF after staying illuminated for approximately two seconds.

CAUTION:

Never start the engine.

Is the inspection result normal?

YES >> GO TO 10.

NO >> Perform the "Self Diagnostic Result" in "AIR PRESSURE MONITOR". Refer to [WT-13, "CONSULT Function"](#).

10. PERFORMING SUPPLEMENTARY WORK

1. Perform tire pressure sensor ID registration. Refer to [WT-26, "Work Procedure"](#).
2. Perform the self-diagnosis of all systems.
3. Erase self-diagnosis results.

>> End of work.

C1704, C1705, C1706, C1707 LOW TIRE PRESSURE

< DTC/CIRCUIT DIAGNOSIS >

DTC/CIRCUIT DIAGNOSIS

C1704, C1705, C1706, C1707 LOW TIRE PRESSURE

DTC Logic

INFOID:0000000012427691

NOTE:

The Signal Tech II Tool [– (J-50190)] can be used to perform the following functions. Refer to the Signal Tech II User Guide for additional information.

- Activate and display TPMS sensor IDs
- Display tire pressure reported by the TPMS sensor
- Read TPMS DTCs
- Register TPMS sensor IDs

DTC DETECTION LOGIC

DTC	Display Item	Malfunction Detected Condition	Possible Cause
C1704	LOW PRESSURE FL	Front LH tire pressure drops to 187.5 kPa (26.5 psi) or less.	<ul style="list-style-type: none">• Low tire pressure• Tire pressure sensor
C1705	LOW PRESSURE FR	Front RH tire pressure drops to 187.5 kPa (26.5 psi) or less.	
C1706	LOW PRESSURE RR	Rear RH tire pressure drops to 187.5 kPa (26.5 psi) or less.	
C1707	LOW PRESSURE RL	Rear LH tire pressure drops to 187.5 kPa (26.5 psi) or less.	

DTC CONFIRMATION PROCEDURE

1. PERFORM SELF DIAGNOSTIC RESULT

With CONSULT

1. Check tire pressure for all wheels and adjust to the specified value. Refer to [WT-82, "Tire Air Pressure"](#).
2. Drive at a speed of 40 km/h (25 MPH) or more for 3 minutes, and then drive the vehicle at any speed for 10 minutes.
3. Select "Self Diagnostic Result" mode in "AIR PRESSURE MONITOR".
4. Check DTC.

Is DTC C1704, C1705, C1706, or C1707 detected?

- YES >> Proceed to [WT-31, "Diagnosis Procedure"](#).
NO >> Inspection End.

Diagnosis Procedure

INFOID:0000000012427692

NOTE:

The Signal Tech II Tool [– (J-50190)] can be used to perform the following functions. Refer to the Signal Tech II User Guide for additional information.

- Activate and display TPMS sensor IDs
- Display tire pressure reported by the TPMS sensor
- Read TPMS DTCs
- Register TPMS sensor IDs

1. TIRE PRESSURE SENSOR ID REGISTRATION

Perform tire pressure sensor ID registration. Refer to [WT-26, "Work Procedure"](#).

Can the tire pressure sensor ID registration be completed?

- YES >> GO TO 2.
NO >> Replace applicable tire pressure sensor. Refer to [WT-69, "Removal and Installation"](#).

2. CHECK TIRE PRESSURE

Check the air pressure of all wheels. Refer to [WT-82, "Tire Air Pressure"](#).

C1704, C1705, C1706, C1707 LOW TIRE PRESSURE

< DTC/CIRCUIT DIAGNOSIS >

Is the inspection result normal?

YES >> Perform DTC CONFIRMATION PROCEDURE again. Refer to [WT-31, "DTC Logic"](#).

NO >> GO TO 3.

3. CHECK TIRE PRESSURE SIGNAL

Ⓟ **With CONSULT**

1. Adjust tire pressure for all wheels to the specified value. Refer to [WT-82, "Tire Air Pressure"](#).
2. Select "Data Monitor" mode in "AIR PRESSURE MONITOR".
3. Check that the air pressures match the specified value.

Monitor item	Displayed value
AIR PRESS FL	Approximately equal to value indicated on tire gauge for front LH tire
AIR PRESS FR	Approximately equal to value indicated on tire gauge for front RH tire
AIR PRESS RR	Approximately equal to value indicated on tire gauge for rear RH tire
AIR PRESS RL	Approximately equal to value indicated on tire gauge for rear LH tire

Is the inspection result normal?

YES >> Inspection End.

NO >> Repair or replace malfunctioning components.

C1708, C1709, C1710, C1711 TRANSMITTER (NO DATA)

< DTC/CIRCUIT DIAGNOSIS >

C1708, C1709, C1710, C1711 TRANSMITTER (NO DATA)

DTC Logic

INFOID:000000012427693

NOTE:

The Signal Tech II Tool [– (J-50190)] can be used to perform the following functions. Refer to the Signal Tech II User Guide for additional information.

- Activate and display TPMS sensor IDs
- Display tire pressure reported by the TPMS sensor
- Read TPMS DTCs
- Register TPMS sensor IDs

DTC DETECTION LOGIC

DTC	Display Item	Malfunction Detected Condition	Possible Cause
C1708	[NO - DATA] - FL	Data signal from the front LH wheel tire pressure sensor cannot be detected.	<ul style="list-style-type: none">• Driving in area with radio interference.• ID registration incomplete• Tire pressure sensor• Harness or connectors• BCM
C1709	[NO - DATA] - FR	Data signal from the front RH wheel tire pressure sensor cannot be detected.	
C1710	[NO - DATA] - RR	Data signal from the rear RH wheel tire pressure sensor cannot be detected.	
C1711	[NO - DATA] - RL	Data signal from the rear LH wheel tire pressure sensor cannot be detected.	

DTC CONFIRMATION PROCEDURE

1. PERFORM SELF DIAGNOSTIC RESULT

With CONSULT

1. Perform tire pressure sensor ID registration. Refer to [WT-26, "Work Procedure"](#).
2. Drive at a speed of 40 km/h (25 MPH) or more for 3 minutes, and then drive the vehicle at any speed for 10 minutes.

NOTE:

Avoid driving in areas with radio interference.

3. Select "Self Diagnostic Result" mode in "AIR PRESSURE MONITOR".
4. Check DTC.

Is DTC C1708, C1709, C1710, or C1711 detected?

- YES >> Proceed to [WT-33, "Diagnosis Procedure"](#).
NO >> Inspection End.

Diagnosis Procedure

INFOID:000000012427694

NOTE:

The Signal Tech II Tool [– (J-50190)] can be used to perform the following functions. Refer to the Signal Tech II User Guide for additional information.

- Activate and display TPMS sensor IDs
- Display tire pressure reported by the TPMS sensor
- Read TPMS DTCs
- Register TPMS sensor IDs

Regarding Wiring Diagram information, refer to [WT-19, "Wiring Diagram"](#).

1. CHECK TIRE PRESSURE SIGNAL

With CONSULT

1. Select "Data Monitor" mode in "AIR PRESSURE MONITOR".
2. Check that the air pressures match the specified value.

C1708, C1709, C1710, C1711 TRANSMITTER (NO DATA)

< DTC/CIRCUIT DIAGNOSIS >

Monitor item	Displayed value
AIR PRESS FL	Approximately equal to specified value. Refer to WT-82. "Tire Air Pressure" .
AIR PRESS FR	
AIR PRESS RR	
AIR PRESS RL	

Are all tire pressures displayed 0 kPa (psi)?

YES >> GO TO 2.

NO >> Replace applicable tire pressure sensor. Refer to [WT-69. "Removal and Installation"](#).

2. CHECK BCM POWER CIRCUIT

Check voltage between BCM connector M20 terminal 161 and ground.

BCM		Ground	Voltage (Approx.)
Connector	Terminal		
M20	161	—	Battery voltage

Is the inspection result normal?

YES >> GO TO 3.

NO >> Repair or replace harness or connectors.

3. CHECK BCM GROUND CIRCUIT

Check continuity between BCM connector M20 and ground.

BCM		Ground	Continuity
Connector	Terminal		
M20	170	—	Yes
	171		

Is the inspection result normal?

YES >> GO TO 4.

NO >> Repair or replace harness or connectors.

4. TIRE PRESSURE SENSOR ID REGISTRATION

Perform tire pressure sensor ID registration. Refer to [WT-26. "Work Procedure"](#).

Can the tire pressure sensor ID registration be completed?

YES >> GO TO 5.

NO >> Replace applicable tire pressure sensor. Refer to [WT-69. "Removal and Installation"](#).

5. RECHECK TIRE PRESSURE SIGNAL

With CONSULT

1. Drive at a speed of 40 km/h (25 MPH) or more for 3 minutes, and then drive the vehicle at any speed for 10 minutes.
2. Select "Data Monitor" mode in "AIR PRESSURE MONITOR".
3. Check that the air pressures match the specified value.

Monitor item	Displayed value
AIR PRESS FL	Approximately equal to specified value. Refer to WT-82. "Tire Air Pressure" .
AIR PRESS FR	
AIR PRESS RR	
AIR PRESS RL	

Does Data Monitor display specified value without turning tire pressure warning lamp ON?

YES >> Inspection End.

C1708, C1709, C1710, C1711 TRANSMITTER (NO DATA)

< DTC/CIRCUIT DIAGNOSIS >

NO >> Replace BCM. Refer to [BCS-76. "Removal and Installation"](#) (with Intelligent Key system) or [BCS-137. "Removal and Installation"](#) (without Intelligent Key system).

A

B

C

D

WT

F

G

H

I

J

K

L

M

N

O

P

C1716, C1717, C1718, C1719 TRANSMITTER (PRESSURE DATA)

< DTC/CIRCUIT DIAGNOSIS >

C1716, C1717, C1718, C1719 TRANSMITTER (PRESSURE DATA)

DTC Logic

INFOID:000000012427695

NOTE:

The Signal Tech II Tool [– (J-50190)] can be used to perform the following functions. Refer to the Signal Tech II User Guide for additional information.

- Activate and display TPMS sensor IDs
- Display tire pressure reported by the TPMS sensor
- Read TPMS DTCs
- Register TPMS sensor IDs

DTC DETECTION LOGIC

DTC	Display Item	Malfunction Detection Condition	Possible Cause
C1716	[PRESSDATA ERR] FL	Malfunction in the tire pressure data from the front LH wheel tire pressure sensor.	<ul style="list-style-type: none">• Excessive tire pressure• ID registration incomplete• Tire pressure sensor• BCM
C1717	[PRESSDATA ERR] FR	Malfunction in the tire pressure data from the front RH wheel tire pressure sensor.	
C1718	[PRESSDATA ERR] RR	Malfunction in the tire pressure data from the rear RH wheel tire pressure sensor.	
C1719	[PRESSDATA ERR] RL	Malfunction in the tire pressure data from the rear LH wheel tire pressure sensor.	

DTC CONFIRMATION PROCEDURE

1. PERFORM SELF DIAGNOSTIC RESULT

With CONSULT

1. Check tire pressure for all wheels and adjust to the specified value. Refer to [WT-82, "Tire Air Pressure"](#).
2. Drive at a speed of 40 km/h (25 MPH) or more for 3 minutes, and then drive the vehicle at any speed for 10 minutes.
3. Select "Self Diagnostic Result" mode of "AIR PRESSURE MONITOR".
4. Check DTC.

Is DTC C1716, C1717, C1718, or C1719 detected?

- YES >> Proceed to [WT-36, "Diagnosis Procedure"](#).
NO >> Inspection End.

Diagnosis Procedure

INFOID:000000012427696

NOTE:

The Signal Tech II Tool [– (J-50190)] can be used to perform the following functions. Refer to the Signal Tech II User Guide for additional information.

- Activate and display TPMS sensor IDs
- Display tire pressure reported by the TPMS sensor
- Read TPMS DTCs
- Register TPMS sensor IDs

1. TIRE PRESSURE SENSOR ID REGISTRATION

Perform tire pressure sensor ID registration. Refer to [WT-26, "Work Procedure"](#).

Can the tire pressure sensor ID registration be completed?

- YES >> GO TO 2.
NO >> Replace applicable tire pressure sensor. Refer to [WT-69, "Removal and Installation"](#).

2. CHECK TIRE PRESSURE SIGNAL

With CONSULT

1. Adjust tire pressure for all wheels to the specified value. Refer to [WT-82, "Tire Air Pressure"](#).
2. Select "Data Monitor" mode in "AIR PRESSURE MONITOR".
3. Check that the air pressures match the specified value.

C1716, C1717, C1718, C1719 TRANSMITTER (PRESSURE DATA)

< DTC/CIRCUIT DIAGNOSIS >

Monitor item	Displayed value	A
AIR PRESS FL	Approximately equal to specified value. Refer to WT-82, "Tire Air Pressure" .	
AIR PRESS FR		B
AIR PRESS RR		
AIR PRESS RL		

Is the inspection result normal?

YES >> Inspection End.

NO >> Replace BCM. Refer to [BCS-76, "Removal and Installation"](#) (with Intelligent Key system) or [BCS-137, "Removal and Installation"](#) (without Intelligent Key system).

WT

F

G

H

I

J

K

L

M

N

O

P

C1729 VEHICLE SPEED SIGNAL

< DTC/CIRCUIT DIAGNOSIS >

C1729 VEHICLE SPEED SIGNAL

DTC Logic

INFOID:000000012427697

NOTE:

The Signal Tech II Tool [– (J-50190)] can be used to perform the following functions. Refer to the Signal Tech II User Guide for additional information.

- Activate and display TPMS sensor IDs
- Display tire pressure reported by the TPMS sensor
- Read TPMS DTCs
- Register TPMS sensor IDs

DTC DETECTION LOGIC

DTC	Display Item	Malfunction Detected Condition	Possible Cause
C1729	VHCL SPEED SIG ERR	Vehicle speed signal not detected.	<ul style="list-style-type: none">• CAN communication• BCM• ABS actuator and electric unit (control unit)

DTC CONFIRMATION PROCEDURE

1. PERFORM SELF DIAGNOSTIC RESULT

With CONSULT

1. Drive at a speed of 40 km/h (25 MPH) or more for 3 minutes, and then drive the vehicle at any speed for 10 minutes.
2. Select “Self Diagnostic Result” mode of “AIR PRESSURE MONITOR”.
3. Check DTC.

Is DTC C1729 detected?

- YES >> Proceed to [WT-38, "Diagnosis Procedure"](#).
NO >> Inspection End.

Diagnosis Procedure

INFOID:000000012427698

NOTE:

The Signal Tech II Tool [– (J-50190)] can be used to perform the following functions. Refer to the Signal Tech II User Guide for additional information.

- Activate and display TPMS sensor IDs
- Display tire pressure reported by the TPMS sensor
- Read TPMS DTCs
- Register TPMS sensor IDs

1. PERFORM SELF DIAGNOSTIC RESULT FOR ABS ACTUATOR AND ELECTRIC UNIT (CONTROL UNIT)

With CONSULT

Perform “Self Diagnostic Result” for “ABS”. Refer to [BRC-45, "CONSULT Function"](#).

Are any DTCs detected?

- YES >> Refer to [BRC-57, "DTC Index"](#).
NO >> Replace the BCM. Refer to [BCS-76, "Removal and Installation"](#) (with Intelligent Key system) or [BCS-137, "Removal and Installation"](#) (without Intelligent Key system).

C1730, C1731, C1732, C1733 FLAT TIRE

< DTC/CIRCUIT DIAGNOSIS >

C1730, C1731, C1732, C1733 FLAT TIRE

DTC Logic

INFOID:000000012427699

NOTE:

The Signal Tech II Tool [– (J-50190)] can be used to perform the following functions. Refer to the Signal Tech II User Guide for additional information.

- Activate and display TPMS sensor IDs
- Display tire pressure reported by the TPMS sensor
- Read TPMS DTCs
- Register TPMS sensor IDs

DTC DETECTION LOGIC

DTC	Display Item	Malfunction Detected Condition	Possible Cause
C1730	FLAT TIRE FL	Front LH tire pressure is 70 kPa (0.7 kg/cm ² , 10 psi) or less.	• Low tire pressure • Tire pressure sensor
C1731	FLAT TIRE FR	Front RH tire pressure is 70 kPa (0.7 kg/cm ² , 10 psi) or less.	
C1732	FLAT TIRE RR	Rear RH tire pressure is 70 kPa (0.7 kg/cm ² , 10 psi) or less.	
C1733	FLAT TIRE RL	Rear LH tire pressure is 70 kPa (0.7 kg/cm ² , 10 psi) or less.	

DTC CONFIRMATION PROCEDURE

1. PERFORM SELF DIAGNOSTIC RESULT

With CONSULT

1. Drive at a speed of 40 km/h (25 MPH) or more for 3 minutes, and then drive the vehicle at any speed for 10 minutes.
2. Select “Self Diagnostic Result” mode of “AIR PRESSURE MONITOR”.
3. Check DTC.

Is DTC C1730, C1731, C1732, or C1733 detected?

- YES >> Proceed to [WT-39, "Diagnosis Procedure"](#).
NO >> Inspection End.

Diagnosis Procedure

INFOID:000000012427700

NOTE:

The Signal Tech II Tool [– (J-50190)] can be used to perform the following functions. Refer to the Signal Tech II User Guide for additional information.

- Activate and display TPMS sensor IDs
- Display tire pressure reported by the TPMS sensor
- Read TPMS DTCs
- Register TPMS sensor IDs

1. TIRE PRESSURE SENSOR ID REGISTRATION

Perform tire pressure sensor ID registration. Refer to [WT-26, "Work Procedure"](#).

Can the tire pressure sensor ID registration be completed?

- YES >> GO TO 2.
NO >> Replace applicable tire pressure sensor. Refer to [WT-69, "Removal and Installation"](#).

2. CHECK TIRE PRESSURE

Check the air pressure of all wheels. Refer to [WT-82, "Tire Air Pressure"](#).

Is the inspection result normal?

- YES >> Perform DTC CONFIRMATION PROCEDURE again. Refer to [WT-39, "DTC Logic"](#).

C1730, C1731, C1732, C1733 FLAT TIRE

< DTC/CIRCUIT DIAGNOSIS >

NO >> GO TO 3.

3. CHECK TIRE PRESSURE SIGNAL

With CONSULT

1. Adjust tire pressure for all wheels to the specified value. Refer to [WT-82, "Tire Air Pressure"](#).
2. Select "Data Monitor" mode in "AIR PRESSURE MONITOR".
3. Check that the air pressures match the specified value.

Monitor item	Displayed value
AIR PRESS FL	Approximately equal to value indicated on tire gauge for front LH tire
AIR PRESS FR	Approximately equal to value indicated on tire gauge for front RH tire
AIR PRESS RR	Approximately equal to value indicated on tire gauge for rear RH tire
AIR PRESS RL	Approximately equal to value indicated on tire gauge for rear LH tire

Is the inspection result normal?

- YES >> Inspection End.
NO >> Repair or replace malfunctioning components.

C1734 BCM

< DTC/CIRCUIT DIAGNOSIS >

C1734 BCM

DTC Logic

INFOID:000000012427701

NOTE:

The Signal Tech II Tool [– (J-50190)] can be used to perform the following functions. Refer to the Signal Tech II User Guide for additional information.

- Activate and display TPMS sensor IDs
- Display tire pressure reported by the TPMS sensor
- Read TPMS DTCs
- Register TPMS sensor IDs

DTC DETECTION LOGIC

DTC	Display Item	Malfunction Detected Condition	Possible Cause
C1734	CONTROL UNIT	TPMS malfunction in BCM.	BCM

DTC CONFIRMATION PROCEDURE

1. PERFORM SELF DIAGNOSTIC RESULT

With CONSULT

1. Turn ignition switch ON.
2. Select "Self Diagnostic Result" mode of "AIR PRESSURE MONITOR".
3. Check DTC.

Is DTC C1734 detected?

- YES >> Proceed to [WT-41, "Diagnosis Procedure"](#).
NO >> Inspection End.

Diagnosis Procedure

INFOID:000000012427702

NOTE:

The Signal Tech II Tool [– (J-50190)] can be used to perform the following functions. Refer to the Signal Tech II User Guide for additional information.

- Activate and display TPMS sensor IDs
- Display tire pressure reported by the TPMS sensor
- Read TPMS DTCs
- Register TPMS sensor IDs

Regarding Wiring Diagram information, refer to [WT-19, "Wiring Diagram"](#).

1. CHECK BCM HARNESS CONNECTORS

Check BCM harness connectors for damage or loose connections.

Is the inspection result normal?

- YES >> Repair or replace connectors.
NO >> GO TO 2.

2. CHECK BCM POWER SUPPLY AND GROUND

Check BCM power supply and ground. Refer to [BCS-69, "Diagnosis Procedure"](#) (with Intelligent Key system) or [BCS-130, "Diagnosis Procedure"](#) (without Intelligent Key system).

Is the inspection result normal?

- YES >> GO TO 3.
NO >> Repair or replace harness or connectors.

3. CHECK BCM INPUT/OUTPUT SIGNALS

Check BCM input/output signals. Refer to [BCS-29, "Reference Value"](#) (with Intelligent Key system) or [BCS-97, "Reference Value"](#) (without Intelligent Key system).

Is the inspection result normal?

C1734 BCM

< DTC/CIRCUIT DIAGNOSIS >

YES >> Inspection End.

NO >> Replace BCM. Refer to [BCS-76. "Removal and Installation"](#) (with Intelligent Key system) or [BCS-137. "Removal and Installation"](#) (without Intelligent Key system).

C1735 IGNITION SIGNAL

< DTC/CIRCUIT DIAGNOSIS >

C1735 IGNITION SIGNAL

DTC Logic

INFOID:000000012427703

NOTE:

The Signal Tech II Tool [– (J-50190)] can be used to perform the following functions. Refer to the Signal Tech II User Guide for additional information.

- Activate and display TPMS sensor IDs
- Display tire pressure reported by the TPMS sensor
- Read TPMS DTCs
- Register TPMS sensor IDs

DTC DETECTION LOGIC

DTC	Display Item	Malfunction Detected Condition	Possible Cause
C1735	IGNITION SIGNAL LINE - BCM/TPMS	BCM has detected a mismatch between IGN ON signals.	BCM

DTC CONFIRMATION PROCEDURE

1. PERFORM SELF DIAGNOSTIC RESULT

With CONSULT

1. Turn ignition switch ON.
2. Select “Self Diagnostic Result” mode of “AIR PRESSURE MONITOR”.
3. Check DTC.

Is DTC C1735 detected?

- YES >> Proceed to [WT-43, "Diagnosis Procedure"](#).
NO >> Inspection End.

Diagnosis Procedure

INFOID:000000012427704

NOTE:

The Signal Tech II Tool [– (J-50190)] can be used to perform the following functions. Refer to the Signal Tech II User Guide for additional information.

- Activate and display TPMS sensor IDs
- Display tire pressure reported by the TPMS sensor
- Read TPMS DTCs
- Register TPMS sensor IDs

1. PERFORM BCM SELF-DIAGNOSIS

When DTC “C1735-00” is detected, perform BCM diagnosis.

- >> Perform BCM diagnosis. Refer to [BCS-48, "DTC Index"](#) (with Intelligent Key system) or [BCS-109, "DTC Index"](#) (without Intelligent Key system).

C1765, C1766, C1767, C1768 TIRE PRESSURE SENSOR

< DTC/CIRCUIT DIAGNOSIS >

C1765, C1766, C1767, C1768 TIRE PRESSURE SENSOR

DTC Logic

INFOID:000000012427705

DTC DETECTION LOGIC

DTC	Display Item	Malfunction Detected Condition	Possible Cause
C1765	WHEEL TOP DATA FL (Wheel top data front left)	Malfunction in the wheel top data from the front LH wheel speed sensor.	Wheel speed sensor
C1766	WHEEL TOP DATA FR (Wheel top data front right)	Malfunction in the wheel top data from the front RH wheel speed sensor.	
C1767	WHEEL TOP DATA RR (Wheel top data rear right)	Malfunction in the wheel top data from the rear RH wheel speed sensor.	
C1768	WHEEL TOP DATA RL (Wheel top data rear left)	Malfunction in the wheel top data from the rear LH wheel speed sensor.	

Diagnosis Procedure

INFOID:000000012427706

1. PERFORM ABS ACTUATOR AND ELECTRIC UNIT (CONTROL UNIT) SELF-DIAGNOSIS

When DTC "C1765, C1766, C1767, C1768" is detected, perform ABS system diagnosis.

>> Perform ABS system diagnosis. Refer to [BRC-57, "DTC Index"](#).

C1769 CONFIGURATION SETTING

< DTC/CIRCUIT DIAGNOSIS >

C1769 CONFIGURATION SETTING

DTC Logic

INFOID:000000012427707

This procedure must be performed:

- After replacement of BCM.

DTC DETECTION LOGIC

DTC	Display Item	Malfunction detected condition
C1769	CONFIG SETTING (Configuration setting)	Tire air pressure monitoring system configuration cannot be performed.
		Receiver ID registration cannot be performed.

Diagnosis Procedure

INFOID:000000012427708

1. TIRE PRESSURE MONITORING SYSTEM CONFIGURATION

Perform configuration. Refer to [WT-29, "Work Procedure"](#).

>> GO TO 2.

2. TIRE PRESSURE SENSOR ID REGISTRATION

Perform tire pressure sensor ID registration. Refer to [WT-26, "Work Procedure"](#).

Does low tire pressure warning lamp turn OFF?

YES >> Inspection End.

NO >> Replace BCM. Refer to [BCS-76, "Removal and Installation"](#) (with Intelligent Key system) or [BCS-137, "Removal and Installation"](#) (without Intelligent Key system).

C1770, C1771, C1772, C1773 G SENSOR

< DTC/CIRCUIT DIAGNOSIS >

C1770, C1771, C1772, C1773 G SENSOR

DTC Logic

INFOID:0000000012427709

DTC DETECTION LOGIC

DTC	Display Item	Malfunction Detected Condition	Possible Causes
C1770	G SENSOR FL (G sensor front left)	Malfunction in the G sensor data from front left wheel sensor.	• Tire pressure sensor • Tire pressure receiver
C1771	G SENSOR FR (G sensor front right)	Malfunction in the G sensor data from front right wheel sensor.	
C1772	G SENSOR RL (G sensor rear left)	Malfunction in the G sensor data from rear left wheel sensor.	
C1773	G SENSOR RR (G sensor rear right)	Malfunction in the G sensor data from rear right wheel sensor.	

Diagnosis Procedure

INFOID:0000000012427710

1. REPLACE WHEEL TIRE PRESSURE SENSOR

When DTC "C1770, C1771, C1772, C1773" is detected, replace wheel tire pressure sensor.

>> Replace applicable wheel tire pressure sensor. Refer to [WT-69, "Removal and Installation"](#).

U1000 CAN COMM CIRCUIT

< DTC/CIRCUIT DIAGNOSIS >

U1000 CAN COMM CIRCUIT

Description

INFOID:0000000012427711

CAN (Controller Area Network) is a serial communication line for real time application. It is an on-vehicle multiplex communication line with high data communication speed and excellent error detection ability. Many electronic control units are equipped onto a vehicle, and each control unit shares information and links with other control units during operation (not independent). In CAN communication, control units are connected with 2 communication lines (CAN-H line, CAN-L line) allowing a high rate of information transmission with less wiring. Each control unit communicates data but selectively reads required data only.

DTC Logic

INFOID:0000000012427712

DTC DETECTION LOGIC

DTC	Display item	Malfunction detected condition	Possible cause
U1000	CAN COMM CIRCUIT	BCM is not communicating CAN communication signal for 2 seconds or more.	<ul style="list-style-type: none">• CAN communication malfunction• Malfunction of BCM

DTC CONFIRMATION PROCEDURE

1. PERFORM DTC CONFIRMATION

With CONSULT

1. Drive for several minutes at a speed of 40 km/h (25 MPH) or more.
2. Stop the vehicle.
3. Select "Self Diagnostic Result" mode of "AIR PRESSURE MONITOR".
4. Check DTC.

Is DTC "U1000" detected?

- YES >> Proceed to [WT-47, "Diagnosis Procedure"](#).
NO >> Inspection End.

Diagnosis Procedure

INFOID:0000000012427713

Proceed to [LAN-34, "CAN COMMUNICATION SYSTEM : CAN System Specification Chart"](#).

U1010 CONTROL UNIT (CAN)

< DTC/CIRCUIT DIAGNOSIS >

U1010 CONTROL UNIT (CAN)

DTC Logic

INFOID:0000000012427714

DTC DETECTION LOGIC

DTC	Display Item	Malfunction Detected Condition	Possible cause
U1010	CONTROL UNIT (CAN)	BCM detected internal CAN communication circuit malfunction.	BCM

Diagnosis Procedure

INFOID:0000000012427715

1. REPLACE BCM

When DTC "U1010" is detected, replace BCM.

>> Replace BCM. Refer to [BCS-76, "Removal and Installation"](#) (with Intelligent Key system) or [BCS-137, "Removal and Installation"](#) (without Intelligent Key system).

LOW TIRE PRESSURE WARNING LAMP

< DTC/CIRCUIT DIAGNOSIS >

LOW TIRE PRESSURE WARNING LAMP

Component Function Check

INFOID:000000012427716

1. CHECK THE ILLUMINATION OF THE LOW TIRE PRESSURE WARNING LAMP

Check that the low tire pressure warning lamp is turned OFF after illuminating for approximately 1 second, when the ignition switch is turned ON.

Is the inspection result normal?

YES >> Inspection End.

NO >> Perform trouble diagnosis. Refer to [WT-49. "Diagnosis Procedure"](#).

Diagnosis Procedure

INFOID:000000012427717

1. PERFORM SELF DIAGNOSTIC RESULT

With CONSULT

1. Turn the ignition switch ON.
2. Select "Self Diagnostic Result" of "AIR PRESSURE MONITOR".
3. Check DTC.

Are any DTCs detected?

YES >> Refer to [WT-16. "DTC Index"](#).

NO >> GO TO 2.

2. CHECK LOW TIRE PRESSURE WARNING LAMP SIGNAL

With CONSULT

1. Turn the ignition switch ON.
2. Select "Active Test" mode in "AIR PRESSURE MONITOR".
3. Select "WARNING LAMP" and turn ON the low tire pressure warning lamp.

Is the inspection result normal?

YES >> Check the combination meter. Refer to [MWI-21. "CONSULT Function \(METER/M&A\)"](#).

NO >> Replace the BCM. Refer to [BCS-76. "Removal and Installation"](#) (with Intelligent Key system) or [BCS-137. "Removal and Installation"](#) (without Intelligent Key system).

A
B
C
D
WT
F
G
H
I
J
K
L
M
N
O
P

POWER SUPPLY AND GROUND CIRCUIT

< DTC/CIRCUIT DIAGNOSIS >

POWER SUPPLY AND GROUND CIRCUIT WITH INTELLIGENT KEY SYSTEM

WITH INTELLIGENT KEY SYSTEM : Diagnosis Procedure

INFOID:000000012564856

Regarding Wiring Diagram information, refer to [BCS-51. "Wiring Diagram"](#).

1. CHECK FUSE

Check that the following fuse is not blown.

Terminal No.	Signal name	Fuse No.
161	BCM power supply	7 (10A)

Is the fuse blown?

- YES >> Replace the blown fuse after repairing the affected circuit.
- NO >> GO TO 2.

2. CHECK POWER SUPPLY CIRCUIT

1. Disconnect BCM connector M20.
2. Check voltage between BCM connector M20 and ground.

BCM		Ground	Voltage (Approx.)
Connector	Terminal		
M20	161	—	Battery voltage

Is the inspection result normal?

- YES >> GO TO 3.
- NO >> Repair or replace harness or connectors.

3. CHECK GROUND CIRCUIT

Check continuity between BCM connector M20 and ground.

BCM		Ground	Continuity
Connector	Terminal		
M20	170	—	Yes
	171		

Is the inspection result normal?

- YES >> Inspection End.
- NO >> Repair or replace harness or connectors.

WITHOUT INTELLIGENT KEY SYSTEM

WITHOUT INTELLIGENT KEY SYSTEM : Diagnosis Procedure

INFOID:000000012564857

Regarding Wiring Diagram information, refer to [BCS-112. "Wiring Diagram"](#).

1. CHECK FUSE

Check that the following fuse is not blown.

Terminal No.	Signal name	Fuse No.
161	BCM power supply	7 (10A)

POWER SUPPLY AND GROUND CIRCUIT

< DTC/CIRCUIT DIAGNOSIS >

Is the fuse blown?

- YES >> Replace the blown fuse after repairing the affected circuit.
 NO >> GO TO 2.

2. CHECK POWER SUPPLY CIRCUIT

1. Disconnect BCM connector M20.
2. Check voltage between BCM connector M20 and ground.

BCM		Ground	Voltage (Approx.)
Connector	Terminal		
M20	161	—	Battery voltage

Is the inspection result normal?

- YES >> GO TO 3.
 NO >> Repair or replace harness or connectors.

3. CHECK GROUND CIRCUIT

Check continuity between BCM connector M20 and ground.

BCM		Ground	Continuity
Connector	Terminal		
M20	170	—	Yes
	171		

Is the inspection result normal?

- YES >> Inspection End.
 NO >> Repair or replace harness or connectors.

A
B
C
D
WT
F
G
H
I
J
K
L
M
N
O
P

TPMS

< SYMPTOM DIAGNOSIS >



SYMPTOM DIAGNOSIS

TPMS

Symptom Table

INFOID:000000012427720

LOW TIRE PRESSURE WARNING LAMP SYMPTOM CHART

Diagnosis items	Symptom (Ignition switch ON)	Low tire pressure warning lamp	Cause	Action
Low tire pressure warning lamp	The low tire pressure warning lamp illuminates for 1 second, then turns OFF.	 <p>ON 1 sec > stays OFF SEIA0592E</p>	Wake-up operation for all tire pressure sensors at wheels is completed.	No system malfunctions
	The low tire pressure warning lamp turns ON and stays illuminated.	 <p>Comes ON and stays ON SEIA0598E</p>	Low tire pressure	Check the tire pressure for all wheels and adjust to the specified value. Refer to WT-82, "Tire Air Pressure" .
			Tire pressure monitoring system configuration not performed.	Perform configuration. Refer to WT-29, "Work Procedure" .
		Tire pressure sensor ID registration not performed.	Perform ID registration. Refer to WT-26, "Work Procedure" .	

TPMS

< SYMPTOM DIAGNOSIS >

Diagnosis items	Symptom (Ignition switch ON)	Low tire pressure warning lamp	Cause	Action
Low tire pressure warning lamp	The low tire pressure warning lamp repeats blinking at 0.5-second intervals for 1 minute, and then stays illuminated.	 <p style="text-align: center;">Blinks 1 min</p> <p style="text-align: center;">ON 0.5 sec > OFF 0.5 sec and stays ON</p> <p style="text-align: center;"><small>SEIA0788E</small></p>	The BCM cannot detect tire pressure data signal.	<ul style="list-style-type: none"> Check visually that the tire pressure sensors are installed. If necessary, replace/install the tire pressure sensor(s) and perform tire pressure sensor ID registration. Refer to WT-26. "Work Procedure". Remove the interference radio wave (e.g. battery charger of smart phone).
			The combination meter fuse is open or removed (or pulled out).	Check and install the combination meter fuse. If necessary, replace the fuse.
			The BCM harness connector is removed.	Check the connection conditions of the BCM harness connector, and repair if necessary.
			Tire Pressure Monitoring System (TPMS) malfunction. (except tire pressure monitoring system configuration and/or tire pressure sensor ID registration non-performed)	Perform CONSULT self-diagnosis. Refer to WT-13. "CONSULT Function" .
Hazard warning lamp	The hazard warning lamp does not blink twice when performing ID registration operation.	—	ID registration is not completed.	Perform "ID REGISTRATION CANNOT BE COMPLETED" diagnosis procedure. Refer to WT-59. "Diagnosis Procedure" .

A
B
C
D
WT
F
G
H
I
J
K
L
M
N
O
P

LOW TIRE PRESSURE WARNING LAMP DOES NOT TURN ON

< SYMPTOM DIAGNOSIS >

LOW TIRE PRESSURE WARNING LAMP DOES NOT TURN ON

Description

INFOID:000000012427721

The low tire pressure warning lamp does not turn ON when the ignition switch is turned ON.

NOTE:

The low tire pressure warning lamp turn ON for approximately 1 second and then turns OFF when the ignition switch is turned ON. This is to check that no abnormal condition is present in the tire pressure monitoring system.

The combination meter may be malfunctioning or the tire pressure monitoring system may be malfunctioning if the low tire pressure warning lamp does not turn ON when the ignition switch is turned ON.

Diagnosis Procedure

INFOID:000000012427722

NOTE:

The Signal Tech II Tool [– (J-50190)] can be used to perform the following functions. Refer to the Signal Tech II User Guide for additional information.

- Activate and display TPMS sensor IDs
- Display tire pressure reported by the TPMS sensor
- Read TPMS DTCs
- Register TPMS sensor IDs

1. CHECK LOW TIRE PRESSURE WARNING LAMP SIGNAL

Ⓟ **With CONSULT**

1. Turn the ignition switch ON.

CAUTION:

Never start the engine.

2. Select "Active Test" mode in "AIR PRESSURE MONITOR".
3. Touch "WARNING LAMP" to turn ON the low tire pressure warning lamp.

When "Active Test" is performed, does the low tire pressure warning lamp in the combination meter turn ON?

- YES >> GO TO 2.
NO >> GO TO 3.

2. CHECK LOW TIRE PRESSURE WARNING LAMP OPERATION

Check that the low tire pressure warning lamp is turned OFF after turns ON for approximately 1 second, when the ignition switch is turned ON.

Is the inspection result normal?

- YES >> Check intermittent incident. Refer to [GI-45, "Intermittent Incident"](#).
NO >> Replace the BCM. Refer to [BCS-76, "Removal and Installation"](#) (with Intelligent Key system) or [BCS-137, "Removal and Installation"](#) (without Intelligent Key system).

3. CHECK COMBINATION METER POWER SUPPLY CIRCUIT

Perform the trouble diagnosis for combination meter power supply circuit. Refer to [MWI-60, "COMBINATION METER : Diagnosis Procedure"](#).

Is the inspection result normal?

- YES >> Perform combination diagnosis. Refer to [MWI-53, "Work flow"](#).
NO >> Repair or replace malfunctioning components.

LOW TIRE PRESSURE WARNING LAMP STAYS ON

< SYMPTOM DIAGNOSIS >

LOW TIRE PRESSURE WARNING LAMP STAYS ON

Description

INFOID:000000012427723

The low tire pressure warning lamp does not turn OFF after several seconds have passed after engine starts.

Diagnosis Procedure

INFOID:000000012427724

1. CHECK TIRE PRESSURE

1. Turn the ignition switch ON.

CAUTION:

Never start the engine.

2. Check the tire pressure for all wheels and adjust to the specified value. Refer to [WT-82, "Tire Air Pressure"](#).

Is the inspection result normal?

YES >> GO TO 2.

NO >> Inspect or repair the tires or wheels.

2. CHECK LOW TIRE PRESSURE WARNING LAMP OPERATION

Check that the low tire pressure warning lamp is turned OFF after turns ON for approximately 1 second, when the ignition switch is turned ON.

Is the inspection result normal?

YES >> Inspection End.

NO >> GO TO 3.

3. PERFORM SELF-DIAGNOSIS

 **With CONSULT**

Perform "Self Diagnostic Result" for "AIR PRESSURE MONITOR".

Is DTC detected?

YES >> Perform DTC diagnosis procedure. Refer to [WT-16, "DTC Index"](#).

NO >> GO TO 4.

4. CHECK BCM POWER SUPPLY AND GROUND CIRCUIT

Perform the trouble diagnosis for power supply and ground circuit. Refer to [BCS-69, "Diagnosis Procedure"](#) (with Intelligent Key system) or [BCS-130, "Diagnosis Procedure"](#) (without Intelligent Key system).

Is the inspection result normal?

YES >> Replace BCM. Refer to [BCS-76, "Removal and Installation"](#) (with Intelligent Key system) or [BCS-137, "Removal and Installation"](#) (without Intelligent Key system).

NO >> Repair or replace malfunctioning components.

LOW TIRE PRESSURE WARNING LAMP BLINKS

< SYMPTOM DIAGNOSIS >

LOW TIRE PRESSURE WARNING LAMP BLINKS

Description

INFOID:000000012427725

When the ignition switch is turned ON, the low tire pressure warning lamp blinks. And then 1 minute later, low tire pressure warning lamp turns ON.

Diagnosis Procedure

INFOID:000000012427726

1. CHECK TIRE PRESSURE SENSOR INSTALLATION

Check visually that tire pressure sensors are installed to each wheel correctly.

NOTE:

In the following case, tire pressure monitoring system (TPMS) does not function.

- Tire pressure sensor(s) are not installed.
- Tire pressure sensor(s) of other cars are installed.

Are the genuine NISSAN tire pressure sensors installed correctly?

YES >> GO TO 2.

NO >> Replace and/or Install tire pressure sensor(s). Refer to [WT-69. "Removal and Installation"](#). GO TO 3.

2. PERFORM SELF-DIAGNOSIS

 **With CONSULT**

Perform "Self Diagnostic Result" for "AIR PRESSURE MONITOR".

Is DTC detected?

YES >> Perform DTC diagnosis procedure. Refer to [WT-16. "DTC Index"](#).

NO >> GO TO 4.

3. TIRE PRESSURE SENSOR ID REGISTRATION

Perform tire pressure sensor ID registration. Refer to [WT-26. "Work Procedure"](#).

Is tire pressure sensor ID registration completed?

YES >> Adjust the tire pressure for all wheels specified to the value. Refer to [WT-82. "Tire Air Pressure"](#).

NO >> Perform diagnosis procedure of "ID REGISTRATION CANNOT BE COMPLETED". Refer to [WT-59. "Diagnosis Procedure"](#).

4. CHECK BCM POWER SUPPLY AND GROUND CIRCUIT

Perform the diagnosis for BCM power supply and ground circuit. Refer to [BCS-69. "Diagnosis Procedure"](#) (with Intelligent Key system) or [BCS-130. "Diagnosis Procedure"](#) (without Intelligent Key system).

Is the inspection result normal?

YES >> Replace BCM. Refer to [BCS-76. "Removal and Installation"](#) (with Intelligent Key system) or [BCS-137. "Removal and Installation"](#) (without Intelligent Key system).

NO >> Repair or replace malfunctioning components.

LOW TIRE PRESSURE LOCATION INDICATOR DOES NOT DISPLAY

< SYMPTOM DIAGNOSIS >

LOW TIRE PRESSURE LOCATION INDICATOR DOES NOT DISPLAY

Description

INFOID:000000012427727

When low tire pressure, low tire location indicator does not display though low tire pressure warning lamp turns ON.

Diagnosis Procedure

INFOID:000000012427728

1. CHECK COMBINATION METER

Check combination meter. Refer to [MWI-53, "Work flow"](#).

Is the inspection result normal?

YES >> GO TO 2.

NO >> Repair or replace malfunctioning components.

2. CHECK LOW TIRE PRESSURE WHEEL LOCATION INDICATOR OPERATION

Check that the low tire pressure location indicator is turned OFF after turns ON for approximately 1 second, when the ignition switch is turned ON.

Is the inspection result normal?

YES >> Check intermittent incident. Refer to [GI-45, "Intermittent Incident"](#).

NO >> Replace the BCM. Refer to [BCS-76, "Removal and Installation"](#) (with Intelligent Key system) or [BCS-137, "Removal and Installation"](#) (without Intelligent Key system).

A
B
C
D
E
F
G
H
I
J
K
L
M
N
O
P

WT

LOW TIRE PRESSURE LOCATION INDICATOR CONTINUES DISPLAYING

< SYMPTOM DIAGNOSIS >

LOW TIRE PRESSURE LOCATION INDICATOR CONTINUES DISPLAYING

Description

INFOID:000000012427729

The low tire pressure location indicator continues displaying though low tire pressure warning lamp turns/stays OFF.

Diagnosis Procedure

INFOID:000000012427730

1. CHECK TIRE PRESSURE

1. Turn the ignition switch ON.

CAUTION:

Never start the engine.

2. Check the tire pressure for all wheels and adjust to the specified value. Refer to [WT-82, "Tire Air Pressure"](#).

Is the inspection result normal?

YES >> GO TO 2.

NO >> Inspect or repair the tires or wheels.

2. CHECK LOW TIRE PRESSURE LOCATION INDICATOR

Check low tire pressure location indicator.

Does low tire pressure location indicator continue displaying?

YES >> GO TO 3.

NO >> Inspection End.

3. PERFORM SELF-DIAGNOSIS

Ⓟ With CONSULT

Perform "Self Diagnostic Result" for "AIR PRESSURE MONITOR".

Is DTC detected?

YES >> Perform DTC diagnosis procedure. Refer to [WT-16, "DTC Index"](#).

NO >> GO TO 4.

4. CHECK BCM POWER SUPPLY AND GROUND CIRCUIT

Perform the trouble diagnosis for power supply and ground circuit. Refer to [BCS-69, "Diagnosis Procedure"](#) (with Intelligent Key system) or [BCS-130, "Diagnosis Procedure"](#) (without Intelligent Key system).

Is the inspection result normal?

YES >> Replace BCM. Refer to [BCS-76, "Removal and Installation"](#) (with Intelligent Key system) or [BCS-137, "Removal and Installation"](#) (without Intelligent Key system).

NO >> Repair or replace malfunctioning components.

ID REGISTRATION CANNOT BE COMPLETED

< SYMPTOM DIAGNOSIS >

ID REGISTRATION CANNOT BE COMPLETED

Description

INFOID:0000000012427731

The ID of the tire pressure sensor installed in each wheel cannot be registered in the tire pressure monitoring system. Inspect the tire pressure sensor or the tire pressure monitoring system circuit.

Diagnosis Procedure

INFOID:0000000012427732

1. CHECK TIRE PRESSURE SENSOR ACTIVATION TOOL

Check tire pressure sensor activation tool.

Is the inspection result normal?

YES >> GO TO 2.

NO >> Replace the battery of tire pressure sensor activation tool or repair/replace the tire pressure sensor activation tool.

2. TIRE PRESSURE SENSOR ID REGISTRATION

Perform tire pressure sensor ID registration. Refer to [WT-26, "Work Procedure"](#).

CAUTION:

To perform ID registration, observe the following points:

- Never register ID in a place where radio waves are interfered (e.g. radio tower).
- Never register ID in a place close to vehicles including TPMS.

Is tire pressure sensor ID registration completed?

YES >> Inspection End.

NO >> GO TO 3.

3. CHECK TIRE PRESSURE SIGNAL

Change the work location and perform ID registration again.

NOTE:

Depending on the tire pressure sensor position*, a blind spot exists, and the tire pressure receiver gets poor reception. If an ID registration is performed under this condition, the registration may not be completed. In such case, follow the instructions below to improve the radio wave receiving environment.

- Rotate tire by 90°, 180°, or 270°. (This Step is to change tire pressure sensor position.)
- Open the door close to the tire of which ID registration is ongoing.

*: Radio wave reception condition depends on vehicle architecture (e.g. body harness layout, tire wheel design) or environment.

When ID registration is performed, which wheels do not react?

All wheels react and ID registration is possible.>>Inspection End.

Only certain wheel(s) do not react.>>Replace applicable tire pressure sensor. Refer to [WT-69, "Removal and Installation"](#).

All wheels do not react.>>Replace BCM. Refer to [BCS-76, "Removal and Installation"](#) (with Intelligent Key system) or [BCS-137, "Removal and Installation"](#) (without Intelligent Key system).

EASY FILL TIRE ALERT DOES NOT ACTIVATE

< SYMPTOM DIAGNOSIS >

EASY FILL TIRE ALERT DOES NOT ACTIVATE

Description

INFOID:000000012427733

The Easy Fill tire alert does not function while inflating a tire when the select lever position is in P-range with the ignition switch ON.

NOTE:

- After starting to inflate the tire, it takes a few seconds for the easy fill tire alert to function.
- If there is no response for approximately 15 seconds or more after inflating the tires, cancel the use of the Easy Fill tire alert function or move the vehicle approximately 1 m (3.2 ft.) backward or forward to try again. The air filler pressure may be weak or out of service area.
- For Easy Fill tire alert, Refer to [WT-11, "Easy Fill Tire Alert Function"](#).

Diagnosis Procedure

INFOID:000000012427734

1. LOCATION CHANGE

Move the vehicle to other area and repeat the procedure of the Easy Fill tire alert function. Refer to [WT-11, "Easy Fill Tire Alert Function"](#).

Is the function normal?

YES >> Inspection End.

NO >> GO TO 2.

2. PERFORM BCM SELF-DIAGNOSIS

With CONSULT

Perform "Self Diagnostic Result" for "AIR PRESSURE MONITOR".

Is any DTC detected?

YES >> Perform diagnosis for detected DTC. Refer to [WT-16, "DTC Index"](#).

NO >> GO TO 3.

3. CHECK HAZARD WARNING LAMP OPERATION

Check hazard warning lamp operation with hazard switch.

Does the hazard warning lamps operate?

YES >> GO TO 4.

NO >> Refer to [EXL-91, "Diagnosis Procedure"](#) (halogen headlamp) or [EXL-222, "Diagnosis Procedure"](#) (LED headlamp).

4. PERFORM SELF DIAGNOSTIC RESULT FOR TCM

With CONSULT

Perform "Self Diagnostic Result" for "TRANSMISSION".

Is any DTC detected?

YES >> Perform diagnosis for detected DTC. Refer to [TM-63, "DTC Index"](#).

NO >> GO TO 5.

5. CHECK HORN OPERATION

Check horn operation.

Is the inspection result normal?

YES >> GO TO 6.

NO >> Repair or replace malfunctioning components.

6. PERFORM SELF DIAGNOSTIC RESULT

With CONSULT

1. Drive at a speed of 40 km/h (25 MPH) or more for 3 minutes, and then drive the vehicle at any speed for 10 minutes.
2. Stop the vehicle.
3. Perform "Self Diagnostic Result" for "AIR PRESSURE MONITOR".

Is any DTC detected?

YES >> Perform diagnosis for detected DTC. Refer to [WT-16, "DTC Index"](#).

EASY FILL TIRE ALERT DOES NOT ACTIVATE

< SYMPTOM DIAGNOSIS >

NO >> Replace BCM. Refer to [BCS-76. "Removal and Installation"](#) (with Intelligent Key system) or [BCS-137. "Removal and Installation"](#) (without Intelligent Key system).

A

B

C

D

WT

F

G

H

I

J

K

L

M

N

O

P

NOISE, VIBRATION AND HARSHNESS (NVH) TROUBLESHOOTING

< SYMPTOM DIAGNOSIS >

NOISE, VIBRATION AND HARSHNESS (NVH) TROUBLESHOOTING

NVH Troubleshooting Chart

INFOID:000000012427735

Use the chart below to find the cause of the symptom. If necessary, repair or replace these parts.

Reference page			WT-67	WT-63	WT-64	WT-82	FSU-8	—	—	WT-82	DLN-98	DLN-111	FAX-6 , or FSU-5	RAX-5 or RAX-13	—	—	FAX-6 or FAX-44	BR-6	ST-5	
Possible cause and SUSPECTED PARTS			Improper installation, looseness	Out-of-round	Imbalance	Incorrect tire pressure	Uneven tire wear	Deformation or damage	Non-uniformity	Incorrect tire size	PROPELLER SHAFT (if equipped)	DIFFERENTIAL (if equipped)	FRONT AXLE AND FRONT SUSPENSION	REAR AXLE AND REAR SUSPENSION	TIRE	WHEEL	DRIVE SHAFT	BRAKE	STEERING	
Symptom	TIRE	Noise	x	x	x	x	x	x	x	x	x	x	x	x		x	x	x	x	
		Shake	x	x	x	x	x			x	x		x	x		x	x	x	x	
		Vibration				x					x	x		x	x			x		x
		Shimmy	x	x	x	x	x	x	x	x				x	x		x		x	x
		Shudder	x	x	x	x	x	x			x			x	x		x		x	x
		Poor quality ride or handling	x	x	x	x	x	x			x			x		x	x			
	WHEEL	Noise	x	x	x				x		x	x	x	x	x			x	x	x
		Shake	x	x	x				x					x	x			x	x	x
Shimmy, Shudder		x	x	x				x					x	x	x			x	x	
Poor quality ride or handling		x	x	x				x					x	x	x					

x: Applicable

WHEEL

< PERIODIC MAINTENANCE >

PERIODIC MAINTENANCE

WHEEL

Inspection

INFOID:000000012427736

WHEEL

1. Check tires for wear and improper inflation.
2. Check wheels for deformation, cracks and other damage. If deformed, remove wheel and check wheel runout.
3. Remove tire from wheel and mount wheel on a balancer machine.

CAUTION:

DO NOT use center hole cone-type clamping machines to hold the wheel during tire removal/installation or balancing or damage to the wheel paint, cladding or chrome may result. Use only rim-type or universal lug-type clamping machines to hold the wheel during servicing.

- a. Set dial indicator as shown.
- b. Check runout, if runout value exceeds the limit, replace wheel.

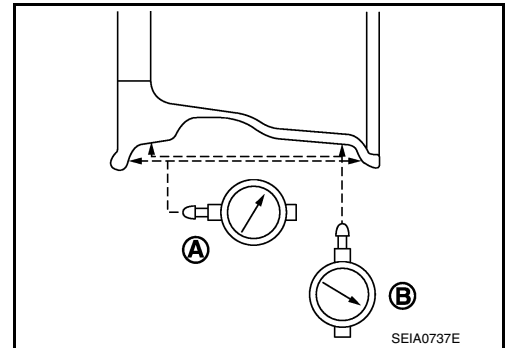

Limit

Axial Runout (A)

Refer to [WT-82, "Wheel"](#).

Radial Runout (B)

Refer to [WT-82, "Wheel"](#).

WHEEL AND TIRE

< PERIODIC MAINTENANCE >

WHEEL AND TIRE

Adjustment

INFOID:000000012427737

BALANCING WHEELS (ADHESIVE WEIGHT TYPE)

Preparation Before Adjustment

Remove inner and outer balance weights from the wheel. Using releasing agent, remove double-faced adhesive tape from the wheel and tire.

CAUTION:

- **Be careful not to scratch the wheel and tire during removal.**
- **After removing double-faced adhesive tape, wipe clean all traces of releasing agent from the wheel and tire.**

Wheel Balance Adjustment

CAUTION:

- **DO NOT use center hole cone-type clamping machines to hold the wheel during tire removal/installation or balancing or damage to the wheel paint, cladding or chrome may result. Use only rim-type or universal lug-type clamping machines to hold the wheel during servicing.**
- If a balancer machine has an adhesive weight mode setting, select the adhesive weight mode setting and skip Step 2 below. If a balancer machine only has the clip-on (rim flange) weight mode setting, follow Step 2 to calculate the correct size adhesive weight.

1. Set wheel and tire on balancer machine using the center hole as a guide. Start the balancer machine.
2. For balancer machines that only have a clip-on (rim flange) weight mode setting, follow this step to calculate the correct size adhesive weight to use. When inner and outer imbalance values are shown on the balancer machine indicator, multiply outer imbalance value by 5/3 (1.67) to determine balance weight that should be used. Select the outer balance weight with a value closest to the calculated value above and install in to the designated outer position of or at the designated angle in relation to the wheel and tire.

- a. Indicated imbalance value $\times 5/3$ (1.67) = balance weight to be installed

Calculation example:

23 g (0.81 oz) $\times 5/3$ (1.67) = 38.33 g (1.35 oz) \Rightarrow 40 g (1.41 oz)
balance weight (closer to calculated balance weight value)

NOTE:

Note that balance weight value must be closer to the calculated balance weight value.

Example:

37.4 \Rightarrow 35 g (1.23 oz)

37.5 \Rightarrow 40 g (1.41 oz)

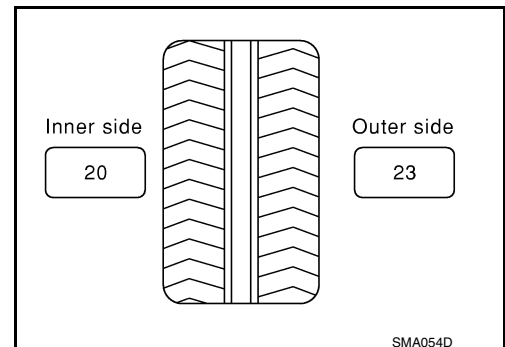

WHEEL AND TIRE

< PERIODIC MAINTENANCE >

3. Install balance weight in the position shown.

CAUTION:

- Do not install the inner balance weight before installing the outer balance weight.
- Before installing the balance weight, be sure to clean the mating surface of the wheel and tire.
- When installing balance weight (1) to wheel and tire, set it into the grooved area (A) on the inner wall of the wheel and tire as shown so that the balance weight center (B) is aligned with the balancer machine indication position (angle) (C).

CAUTION:

- Always use Genuine NISSAN adhesive balance weights.
- Balance weights are non-reusable; always replace with new ones.
- Do not install more than three sheets of balance weights.

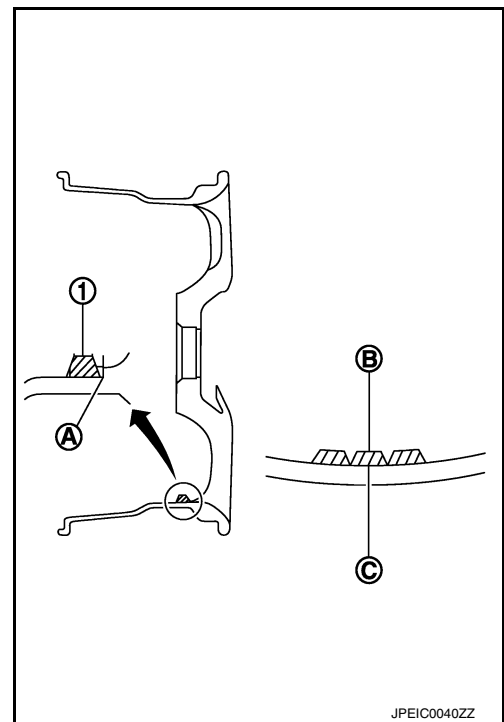

4. If calculated balance weight value exceeds 50 g (1.76 oz), install two balance weight sheets in line with each other as shown.

CAUTION:

Do not install one balance weight sheet on top of another.

5. Start balancer machine again.

6. Install balance weight on inner side of wheel and tire in the balancer machine indication position (angle).

CAUTION:

Do not install more than two balance weights.

7. Start balancer machine. Make sure that inner and outer residual imbalance values are 5 g (0.17 oz) each or below.

8. If either residual imbalance value exceeds 5 g (0.17 oz), repeat installation procedures.

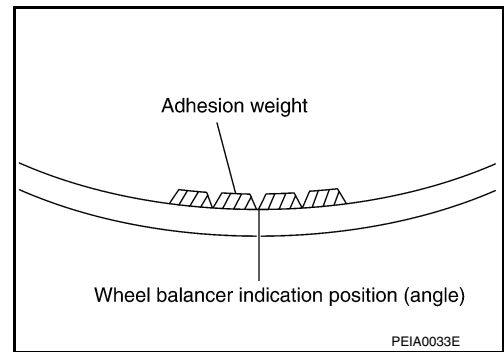

Wheel balance	Dynamic (At flange)	Static (At flange)
Maximum allowable imbalance	Refer to WT-82, "Wheel" .	

TIRE ROTATION

- Follow the maintenance schedule for tire rotation service intervals. Refer to [MA-7, "Introduction of Periodic Maintenance"](#).
- Rotate the wheels and tires front to back in the pattern as shown.
- When installing the wheel, tighten wheel nuts to the specified torque.

WARNING:

- Do not include the spare tire (if equipped) when rotating tires.
- After rotating tires, check and adjust the tire pressure.

CAUTION:

- When installing wheel nuts, tighten them diagonally by dividing the work two to three times in order to prevent the wheels from developing any distortion.
- Be careful not to tighten the wheel nuts to a torque exceeding specification to prevent strain on the disc brake rotor.
- Use Genuine NISSAN wheel nuts.

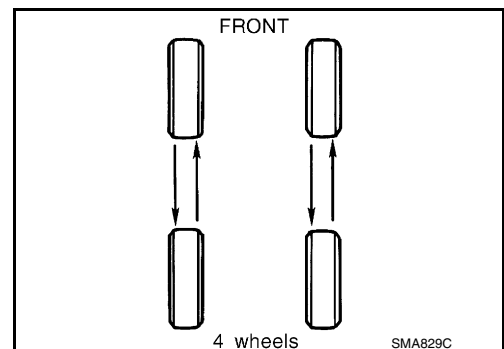

WHEEL AND TIRE

< PERIODIC MAINTENANCE >

Wheel nut tightening torque : Refer to [WT-67, "Exploded View"](#).

- Perform the ID registration after tire rotation. Refer to [WT-26, "Work Procedure"](#).

WHEEL AND TIRE

< REMOVAL AND INSTALLATION >

REMOVAL AND INSTALLATION

WHEEL AND TIRE

Exploded View

INFOID:0000000012427738

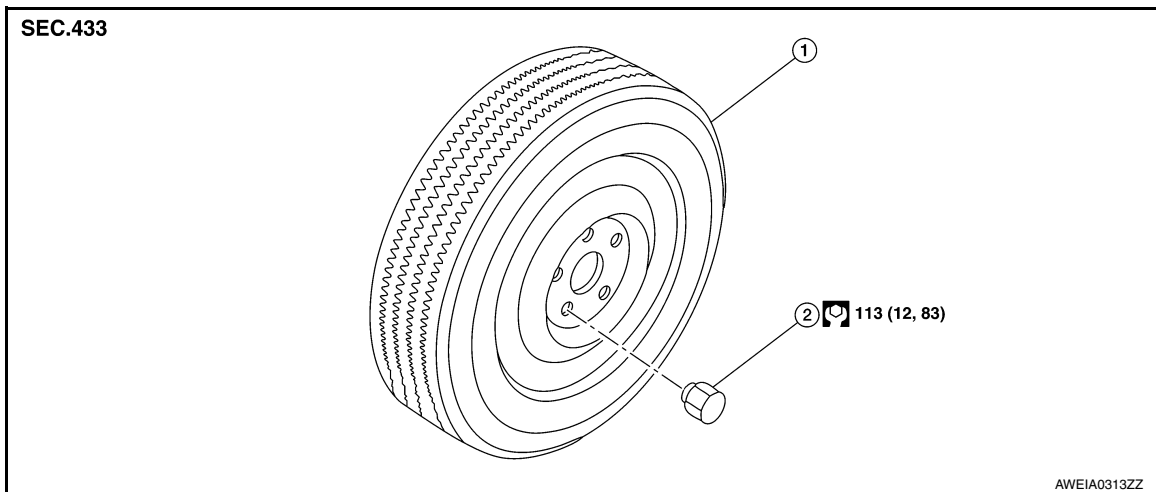

1. Wheel and tire

2. Wheel nut

Removal and Installation

INFOID:0000000012427739

REMOVAL

1. Remove wheel nuts using power tool.
2. Remove wheel and tire.

INSTALLATION

Installation is in the reverse order of removal.

CAUTION:

- **When installing wheel nuts, tighten them diagonally by dividing the work two or three times in order to prevent the wheels from developing any distortion.**
- **Be careful not to tighten the wheel nuts to a torque exceeding specification to prevent strain on the disc brake rotor.**
- **Use Genuine NISSAN wheel nuts.**

TIRE PRESSURE SENSOR

< REMOVAL AND INSTALLATION >

TIRE PRESSURE SENSOR

Exploded View

INFOID:000000012427740

TYPE 1

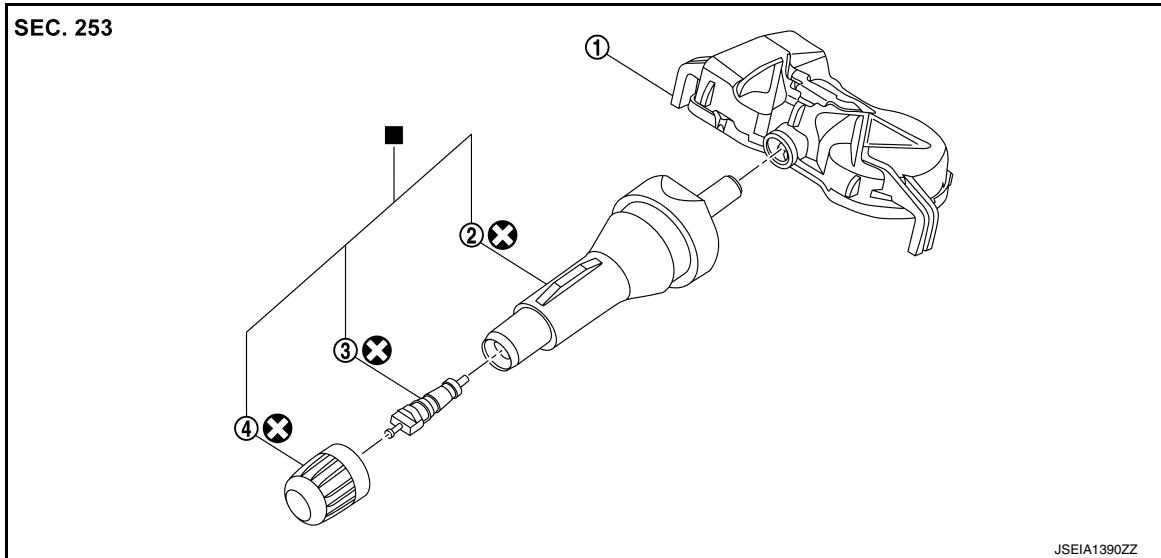

1. Tire pressure sensor

2. Valve

3. Valve core

4. Valve cap

■ : Parts that are replaced as a set when the tire is replaced.

TYPE 2

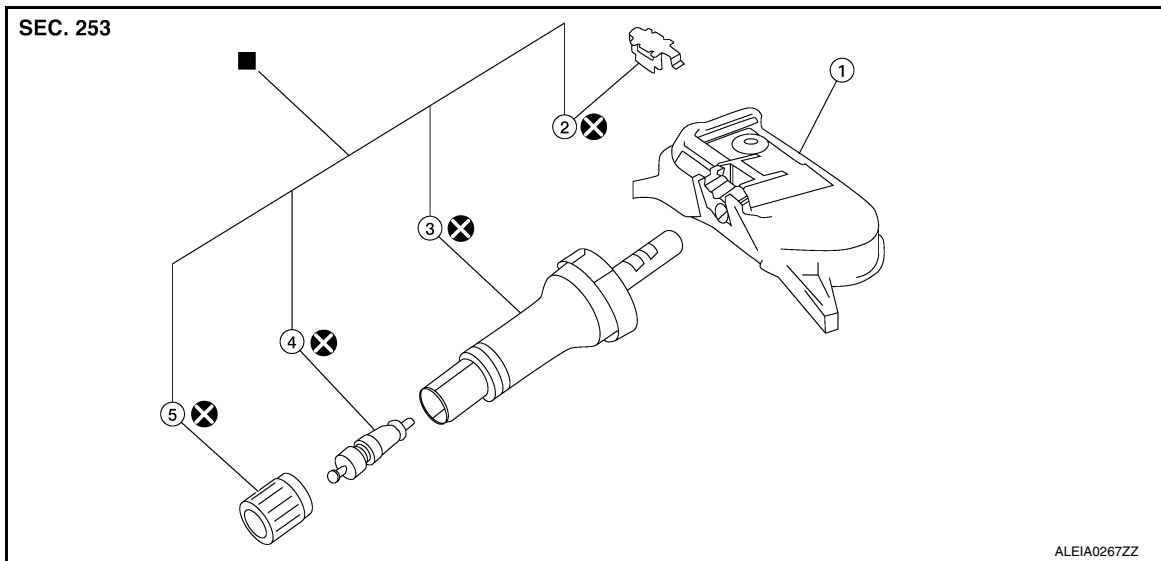

1. Tire pressure sensor

2. Stopper

3. Valve

4. Valve core

5. Valve cap

■ : Parts that are replaced as a set when the tire is replaced.

TIRE PRESSURE SENSOR

< REMOVAL AND INSTALLATION >

TYPE 3

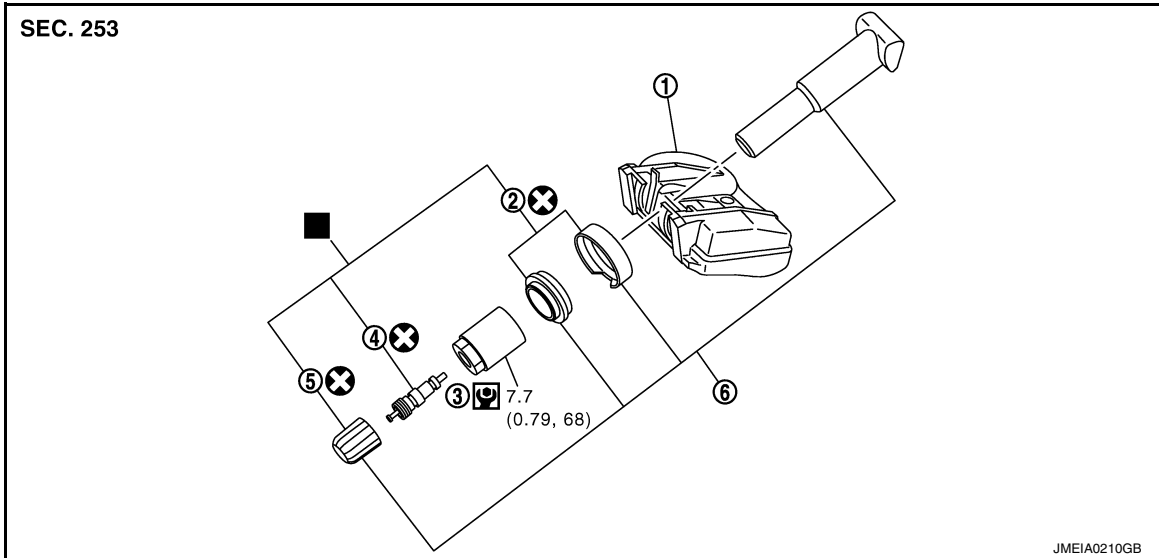

- | | | |
|-------------------------|-------------------------|------------------------|
| 1. Tire pressure sensor | 2. Washer/ Grommet seal | 3. Valve stem nut |
| 4. Valve core | 5. Valve cap | 6. Valve stem assembly |
- : Parts that are replaced as a set when the tire is replaced.

Removal and Installation

INFOID:000000012427741

REMOVAL

Type 1

1. Remove wheel and tire using power tool. Refer to [WT-67, "Removal and Installation"](#).
2. Remove valve cap and valve core to deflate the tire.

NOTE:

If the tire is to be reused, apply a matching mark on the tire in line with the position of the valve stem assembly for the purpose of wheel and tire balance adjustment after installation.

3. Use the tire changer and disengage the tire beads.

CAUTION:

Do not damage the road wheel or tire pressure sensor.

4. Apply bead cream or an equivalent to the tire beads.
5. Carefully lift tire onto turn table and position the valve stem hole and tire pressure sensor (1) 270 degrees from mounting/dismounting head (2).

CAUTION:

Do not damage the wheel or tire pressure sensor.

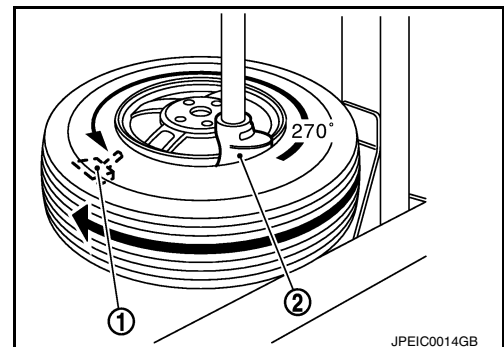

TIRE PRESSURE SENSOR

< REMOVAL AND INSTALLATION >

6. Remove tire pressure sensor (1) according to the following instructions:
 - a. Press the stopper (A) until unlocked.
 - b. Remove the tire pressure sensor from valve (2) in the direction shown (B).

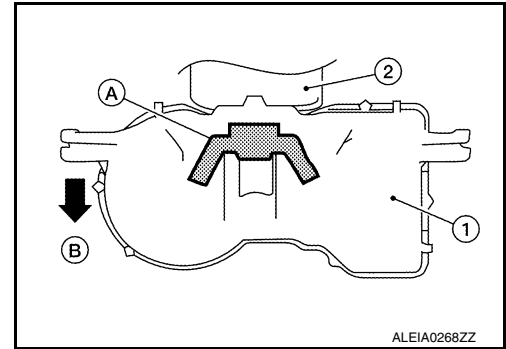

7. Cut the part (A) of valve using suitable tool (B).
CAUTION:
Do not damage the road wheel. Cover the wheel with tape or a clean cloth.

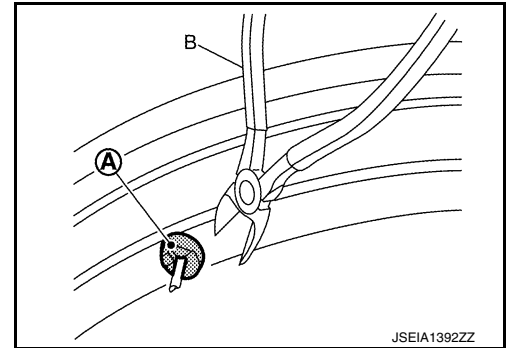

8. Turn the valve 180 degrees using a suitable tool.
CAUTION:
Do not damage the road wheel. Cover the wheel with tape or a clean cloth.

9. Cut the roll pin (A) of valve using suitable tool (B).
CAUTION:
Do not damage the road wheel. Cover the wheel with tape or a clean cloth.

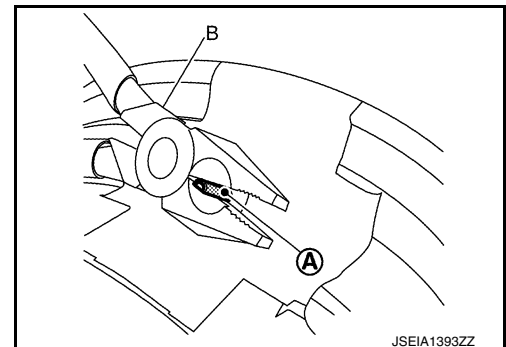

10. Remove the valve (1) from the road wheel (2) using suitable tool (A).
CAUTION:
Do not damage the road wheel.

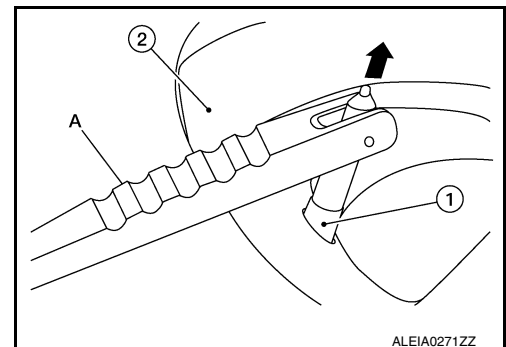

Type 2

1. Remove wheel and tire using power tool. Refer to [WT-67, "Removal and Installation"](#).

2. Remove valve cap and valve core to deflate the tire.

NOTE:

If the tire is to be reused, apply a matching mark on the tire in line with the position of the valve stem assembly for the purpose of wheel and tire balance adjustment after installation.

3. Use the tire changer and disengage the tire beads.

TIRE PRESSURE SENSOR

< REMOVAL AND INSTALLATION >

CAUTION:

Do not damage the road wheel or tire pressure sensor.

4. Apply bead cream or an equivalent to the tire beads.
5. Carefully lift tire onto turn table and position the valve stem hole and tire pressure sensor (1) 270 degrees from mounting/dismounting head (2).

CAUTION:

Do not damage the wheel or tire pressure sensor.

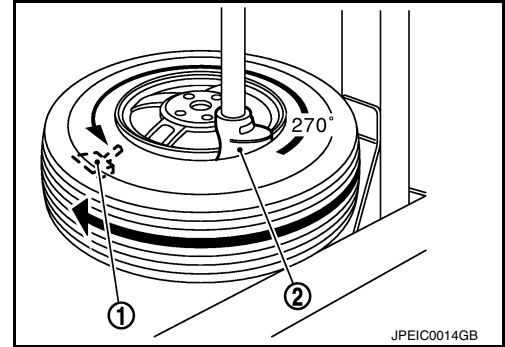

6. Remove tire pressure sensor (1) according to the following instructions:

- a. Remove the stopper (2) in the direction shown (A) using suitable tool.

CAUTION:

Do not damage the wheel or tire pressure sensor.

- b. Remove the tire pressure sensor from valve (3) in the direction shown (B).

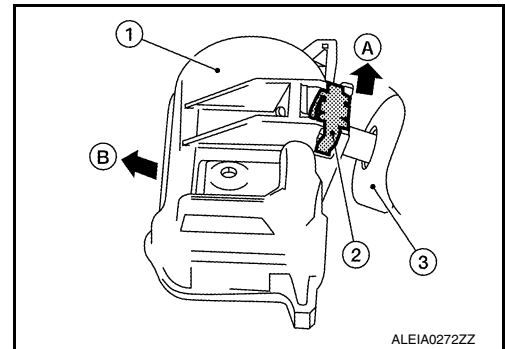

7. Cut the part (A) of valve using suitable tool (B).

CAUTION:

Do not damage the road wheel. Cover wheel with tape or clean cloth.

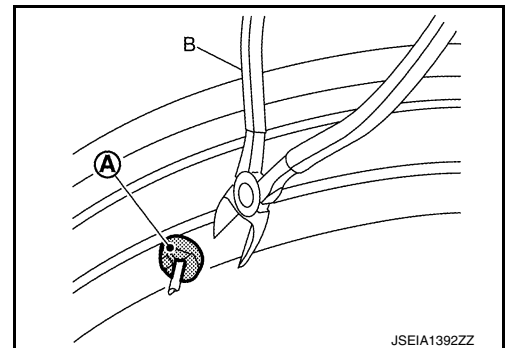

8. Turn the valve 180 degrees using a suitable tool.

CAUTION:

Do not damage the road wheel. Cover wheel with tape or clean cloth.

9. Cut the roll pin (A) of valve using suitable tool (B).

CAUTION:

Do not damage the road wheel. Cover wheel with tape or clean cloth.

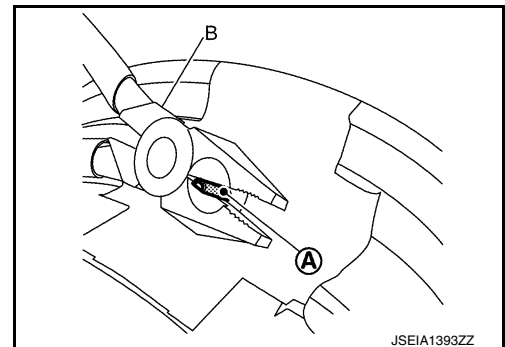

A
B
C
D
WT
F
G
H
I
J
K
L
M
N
O
P

TIRE PRESSURE SENSOR

< REMOVAL AND INSTALLATION >

10. Remove the valve (1) from the road wheel (2) using suitable tool (A).

CAUTION:

Do not damage the road wheel.

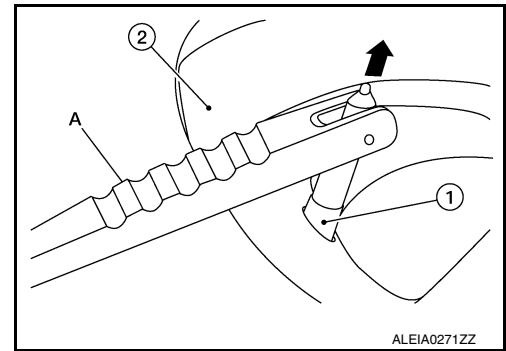

Type 3

1. Remove wheel and tire using power tool. Refer to [WT-67, "Removal and Installation"](#).

2. Remove valve cap and valve core to deflate the tire.

NOTE:

If the tire is to be reused, apply a matching mark on the tire in line with the position of the valve stem assembly for the purpose of wheel and tire balance adjustment after installation.

3. Remove the valve stem nut and allow tire pressure sensor (1) to fall into tire.

4. Lubricate the tire outside bead well with a suitable non-silicone lubricant, and remove outside of tire from the wheel.

CAUTION:

- Do not use silicone lubricant. Use of silicone lubricant will deteriorate the tire and wheel.
- Be sure not to damage the wheel or tire pressure sensor.
- Do not allow lubricant to make contact with tire pressure sensor.
- Verify that the tire pressure sensor (1) is at the bottom of the tire while performing the above.

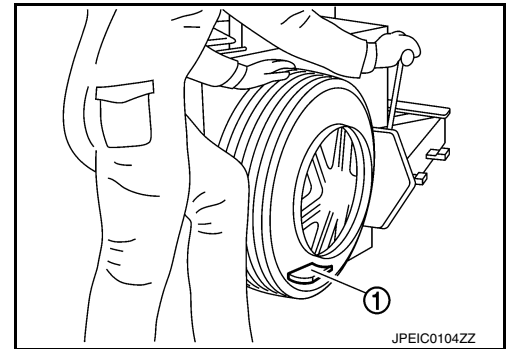

5. Lubricate the tire inside bead well with a suitable non-silicone lubricant, and remove inside of tire from the wheel.

CAUTION:

- Do not use silicone lubricant. Use of silicone lubricant will deteriorate the tire and wheel.
- Be sure not to damage the wheel.

6. Set tire onto the tire changer turntable so that the tire pressure sensor inside the tire is located close to the valve stem hole in the wheel.

7. Turn tire so that the valve stem hole in the wheel is at the bottom and bounce so that the tire pressure sensor (1) inside the tire is near the valve stem hole in the wheel. Carefully lift tire onto turntable and position the valve stem hole in the wheel (and tire pressure sensor) 270 degrees from mounting/dismounting head (2).

CAUTION:

Do not damage the wheel or tire pressure sensor.

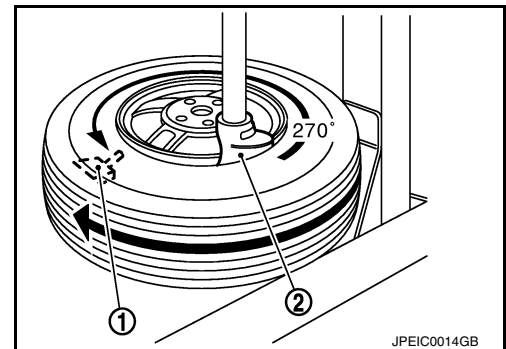

8. Remove the tire pressure sensor from the tire.

9. Remove the grommet seal and washer.

TIRE PRESSURE SENSOR

< REMOVAL AND INSTALLATION >

10. Remove the valve stem in the direction shown by the arrow (←).

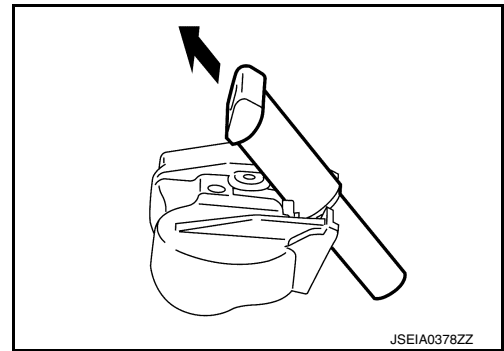

INSTALLATION

Type 1

1. Install valve according to the following instructions:

a. Set valve to road wheel.

CAUTION:

- Do not reuse valve.
- Check the valve (1) direction. Part (A) of valve must be at 12 o'clock to the rim of the road wheel (2).

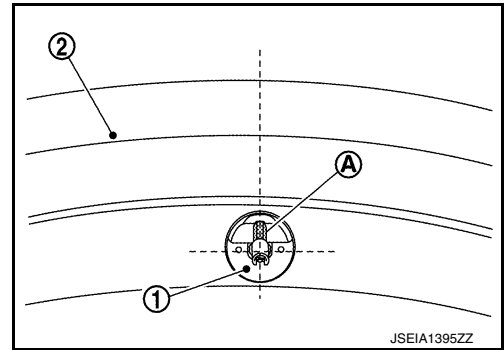

b. Install the valve (1) to road wheel (2) using suitable tool (A).

CAUTION:

- Be sure not to damage the road wheel.
- Insert valve all the way to the road wheel.
- Check that valve contacts horizontally with road wheel.

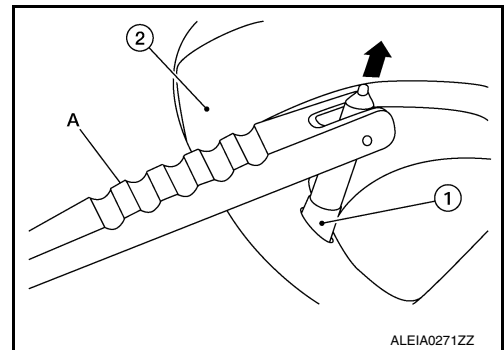

- Check the valve (1) direction. Part (A) of a valve must be at 12 o'clock to the rim of the road wheel.
- If the position is not correct, rotate the valve to the correct position using suitable tool.

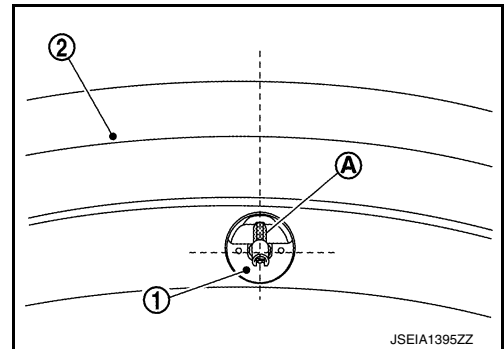

2. Install the tire pressure sensor according to the following instructions:

A
B
C
D
WT
F
G
H
I
J
K
L
M
N
O
P

TIRE PRESSURE SENSOR

< REMOVAL AND INSTALLATION >

- a. Insert the tire pressure sensor (1) to the roll pin (A) of valve (2).

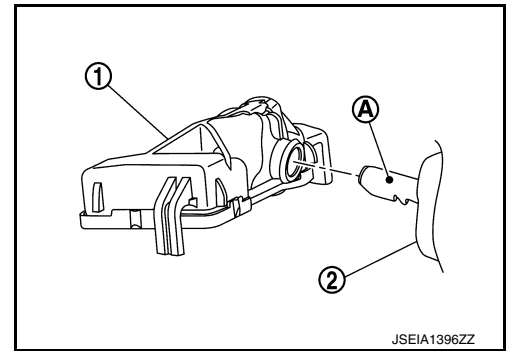

- b. Press the stopper (A) until unlocked.
c. Install the tire pressure sensor (1) to valve (2) in direction (B).

CAUTION:

insert tire pressure sensor all the way to the valve.

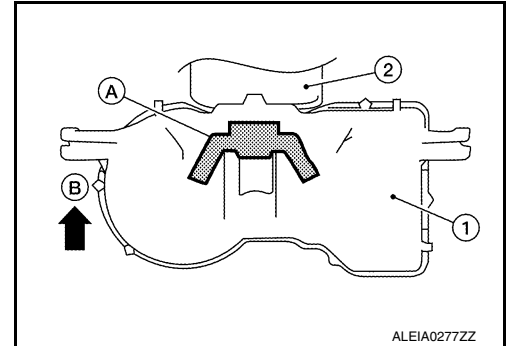

- d. Release the stopper.

CAUTION:

- Pull on the tire pressure sensor to check that the tire pressure sensor is correctly locked on the valve.
 - Position the tire pressure sensor so that the tab on each end contacts the wheel.
- Check the tire pressure sensor (1) contacts (A) with valve (2).

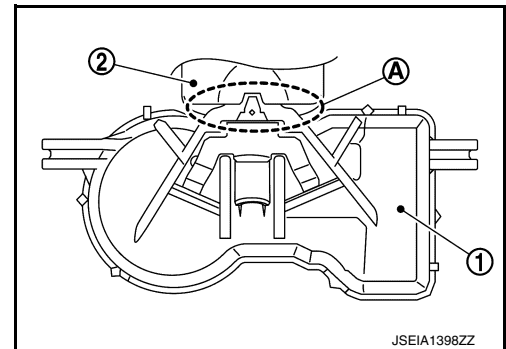

3. Apply bead cream or an equivalent to the tire beads.
4. Install the tire inside beads (1) onto the road wheel (2) in the position shown.

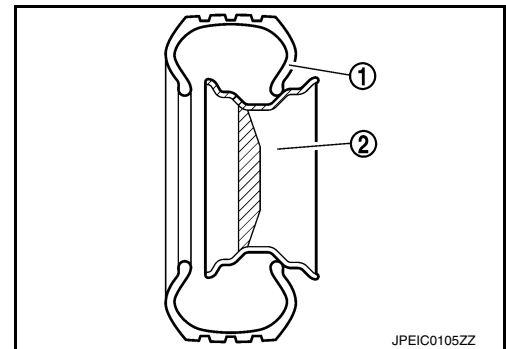

TIRE PRESSURE SENSOR

< REMOVAL AND INSTALLATION >

5. Set the tire onto the turntable so that the tire changer arm (2) is at a position approximately 270 degrees from the tire pressure sensor (1).

CAUTION:

Be sure that the arm does not contact the tire pressure sensor.

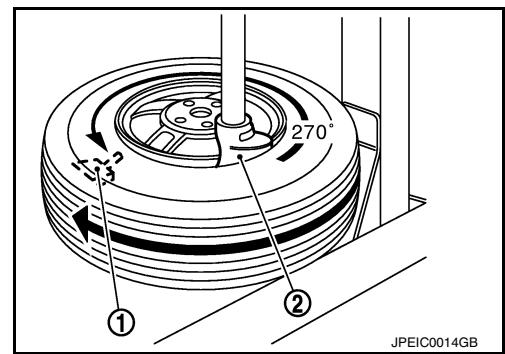

6. Install the tire outer beads onto the road wheel.

CAUTION:

When installing, check that the tire does not turn together with the road wheel.

7. Check the tire pressure for all wheels and adjust to the specified value. Refer to [WT-82. "Tire Air Pressure"](#).

NOTE:

Before adding air, align the tire with the position of the matching mark applied at the time of removal.

8. Install wheel and tire in the appropriate position on vehicle. Refer to [WT-67. "Removal and Installation"](#).

9. Perform the ID registration procedure. Refer to [WT-26. "Description"](#).

Type 2

1. Install valve according to the following instructions:

- a. Set valve to road wheel.

CAUTION:

- Do not reuse valve.
- Check the valve (1) direction. Part (A) of valve must be at 12 o'clock to the rim of the road wheel (2).

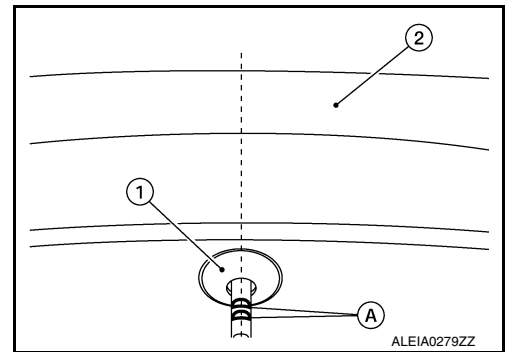

- b. Install the valve (1) to road wheel (2) using suitable tool (A).

CAUTION:

- Be sure not to damage the road wheel.
- Insert valve all the way to the road wheel.
- Check that valve contacts horizontally with road wheel.

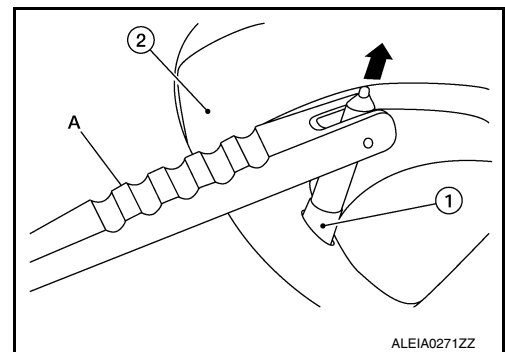

TIRE PRESSURE SENSOR

< REMOVAL AND INSTALLATION >

- Check the valve (1) direction. Part (A) of a valve must be at 12 o'clock to the rim of the road wheel.
- If the position is not correct, rotate the valve to the correct position using suitable tool.

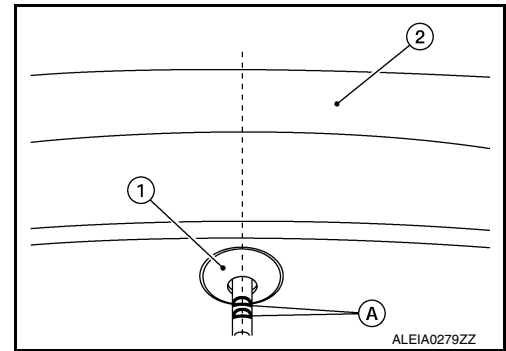

2. Install the tire pressure sensor according to the following instructions:

a. Insert the tire pressure sensor (1) to the roll pin (A) of valve (2).

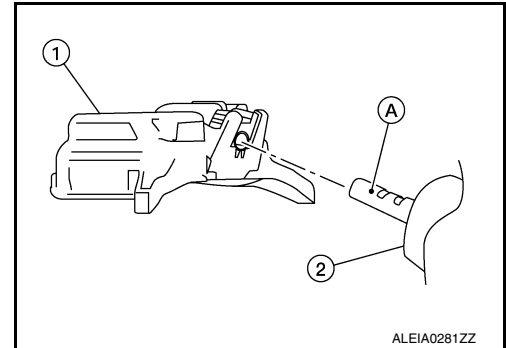

b. Install the stopper (1) until locked in the direction (A) by hand.

CAUTION:

- Do not reuse stopper.
- Be sure not to damage the tire pressure sensor.

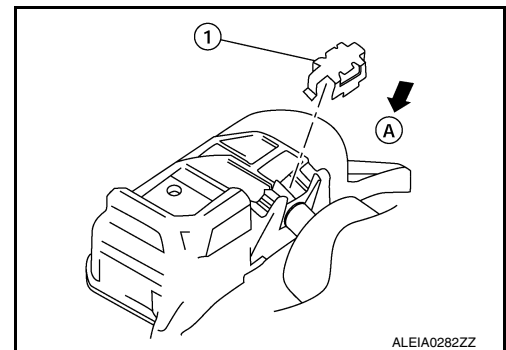

• Be careful with the orientation of the stopper (1).

(A) : Protrusions of stopper

(B) : Valve side

- Pull on the tire pressure sensor to check that the tire pressure sensor is correctly locked on the valve.
- Position the tire pressure sensor so that the tab on each end contacts the wheel.

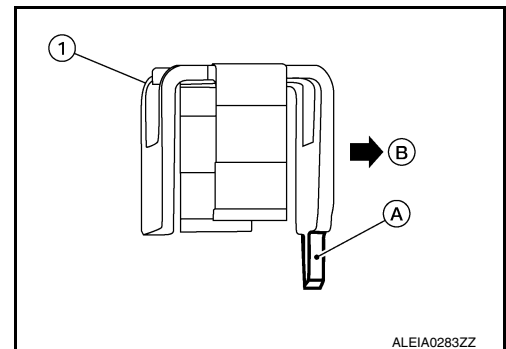

3. Apply bead cream or an equivalent to the tire beads.

TIRE PRESSURE SENSOR

< REMOVAL AND INSTALLATION >

4. Install the tire inside beads (1) onto the road wheel (2) in the position shown.

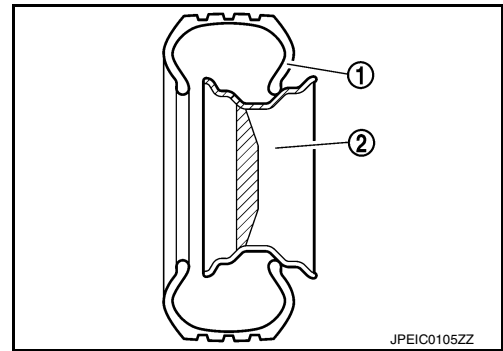

5. Set the tire onto the turntable so that the tire changer arm (2) is at a position approximately 270 degrees from the tire pressure sensor (1).

CAUTION:

Be sure that the arm does not contact the tire pressure sensor.

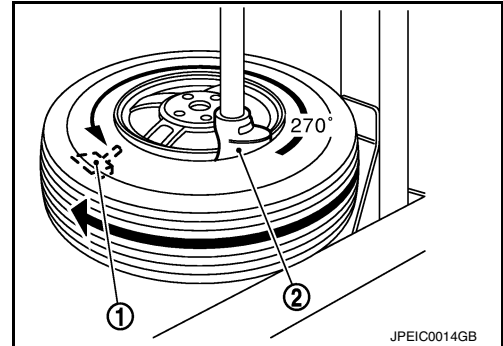

6. Install the tire outer beads onto the road wheel.

CAUTION:

When installing, check that the tire does not turn together with the road wheel.

7. Check the tire pressure for all wheels and adjust to the specified value. Refer to [WT-82, "Tire Air Pressure"](#).

NOTE:

Before adding air, align the tire with the position of the matching mark applied at the time of removal.

8. Install wheel and tire in the appropriate position on vehicle. Refer to [WT-67, "Removal and Installation"](#).

9. Perform the ID registration procedure. Refer to [WT-26, "Description"](#).

Type 3

1. Apply a suitable non-silicone lubricant to the tire inside bead.

CAUTION:

- **Replace the valve stem assembly if the valve stem has deformations, cracks, damage, or corrosion.**
- **Do not use silicone lubricant. Use of silicone lubricant will deteriorate the tire and wheel.**
- **Do not drop or strike the tire pressure sensor. Replace the tire pressure sensor if it has been dropped from higher than one meter.**

2. Install the tire inside bead (1) onto the wheel (2) in the position shown.

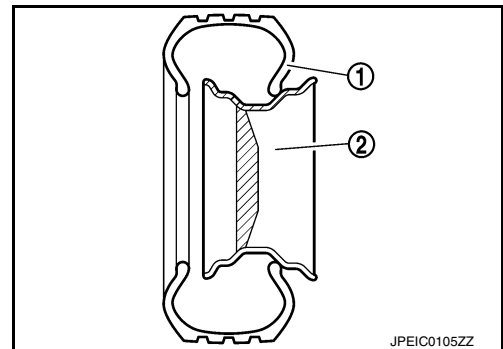

3. Install the valve stem to the tire pressure sensor.

TIRE PRESSURE SENSOR

< REMOVAL AND INSTALLATION >

4. Install the washer (1) onto the valve stem, and then install the grommet seal (2) onto the valve stem.

CAUTION:

- Do not reuse grommet seal or washer.
- Check the direction of the grommet seal.
- Insert the grommet seal all the way to the base.

↑ : Outside

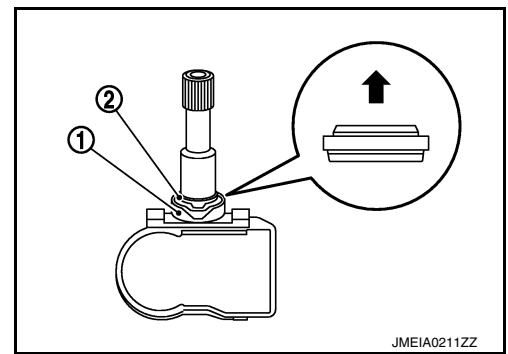

CAUTION:

Direct the cut part (A) of the washer to the center of the valve stem as shown.

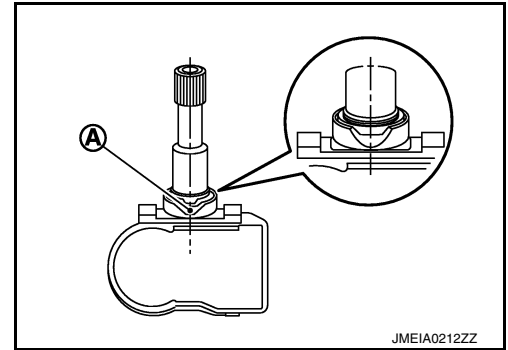

5. Follow the procedure below and install the tire pressure sensor to the wheel.

- a. Check the position of the valve stem (A) before installing tire pressure sensor to the wheel.

CAUTION:

The base of the valve stem must be positioned in the groove of the metal plate as shown.

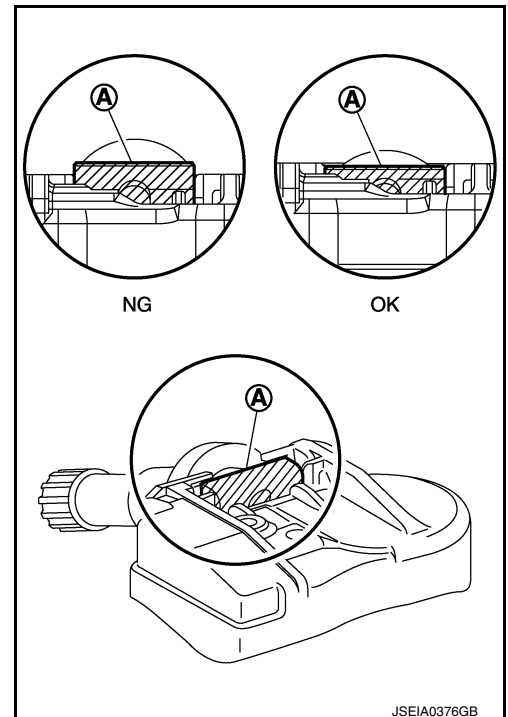

TIRE PRESSURE SENSOR

< REMOVAL AND INSTALLATION >

- b. Hold tire pressure sensor as shown and press the sensor in the direction shown by the arrow (←) to bring into absolute contact with the wheel. Tighten the valve stem nut to the specified torque.

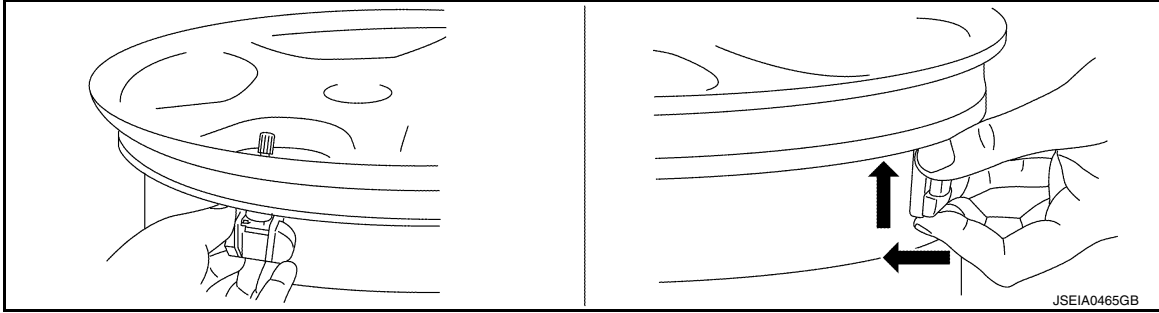

Valve stem nut tightening torque : Refer to [WT-68, "Exploded View"](#).

CAUTION:

- Do not reuse valve core and valve cap.
- Check that grommet seal is free of foreign matter.
- Check that grommet seal contacts horizontally with wheel.
- Check again that the base of valve stem is positioned in the groove of the metal plate.
- Manually tighten valve stem nut all the way to the wheel. (Do not use a power tool to avoid impact.)
- Do not tighten valve stem nut to more than the specified torque. It may cause grommet seal damage.
- Do not tighten valve stem nut to less than the specified torque. It may cause an air leak.

6. Place wheel on turntable of tire machine. Ensure that tire pressure sensor (1) is 270 degrees from mounting/dismounting head (2).

CAUTION:

Do not touch tire pressure sensor with mounting head.

7. Apply a suitable non-silicone lubricant to the tire outside bead.

CAUTION:

- Do not use silicone lubricant. Use of silicone lubricant will deteriorate the tire and wheel.
- Do not allow lubricant to make contact with tire pressure sensor.
- When installing, check that the tire does not turn together with the wheel.

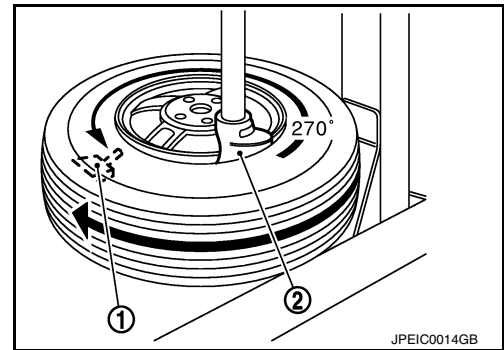

8. Install the tire outside bead onto the wheel as normal.

NOTE:

If the tire is being reused, align the matching mark applied on the tire with the position of the valve stem assembly for the purpose of wheel and tire balance adjustment after installation. Make sure that the tire does not rotate relative to wheel.

9. Install the valve core and inflate tire. Refer to [WT-82, "Tire Air Pressure"](#).

CAUTION:

Do not reuse valve core.

10. Install the valve cap.

CAUTION:

Do not reuse valve cap.

11. Balance the wheel and tire. Refer to [WT-64, "Adjustment"](#).

12. Install wheel and tire in the appropriate position on vehicle. Refer to [WT-67, "Removal and Installation"](#).

13. Perform the ID registration procedure. Refer to [WT-26, "Description"](#).

Disposal

INFOID:0000000012427742

CAUTION:

TIRE PRESSURE SENSOR

< REMOVAL AND INSTALLATION >

- When discarding tire pressure sensor, remove battery (1) from tire pressure sensor.
- Dispose of battery according to the law and local regulations.

1. Remove battery from tire pressure sensor.

NOTE:

The battery is sealed to the tire pressure sensor with urethane.

- a. Remove urethane from tire pressure sensor.
- b. Using a suitable tool cut battery terminal (A), then remove battery from tire pressure sensor.

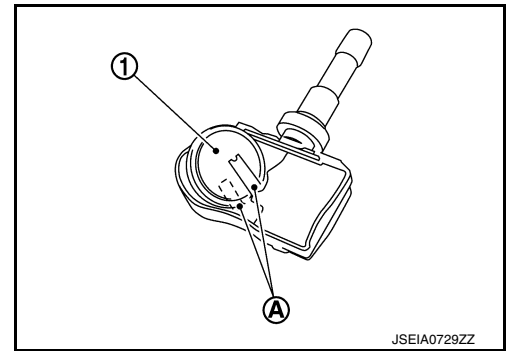

REMOTE KEYLESS ENTRY RECEIVER

< REMOVAL AND INSTALLATION >

REMOTE KEYLESS ENTRY RECEIVER

Removal and Installation

INFOID:000000012427743

The Remote Keyless Entry Receiver is an integral part of the BCM (BODY CONTROL MODULE). Refer to [BCS-76. "Removal and Installation"](#) (WITH INTELLIGENT KEY SYSTEM) or [BCS-137. "Removal and Installation"](#) (WITHOUT INTELLIGENT KEY SYSTEM).

A
B
C
D
E
F
G
H
I
J
K
L
M
N
O
P

WT

SERVICE DATA AND SPECIFICATIONS (SDS)

< SERVICE DATA AND SPECIFICATIONS (SDS)

SERVICE DATA AND SPECIFICATIONS (SDS)

SERVICE DATA AND SPECIFICATIONS (SDS)

Wheel

INFOID:0000000012427744

ALUMINUM WHEEL

Runout	Axial runout	Less than 0.3 mm (0.012 in)
	Radial runout	
Allowable imbalance	Dynamic (At flange)	Less than 5 g (0.17 oz) (one side)
	Static (At flange)	Less than 10 g (0.35 oz)

STEEL WHEEL

Runout		Inside	Outside
	Axial runout		1.0 mm (0.039 in) or less
Radial runout		0.8 mm (0.031 in) or less	0.4 mm (0.016 in) or less
Allowable imbalance	Dynamic (At flange)	Less than 5 g (0.17 oz) (one side)	
	Static (At flange)	Less than 10 g (0.35 oz)	

Tire Air Pressure

INFOID:0000000012427745

Unit: kPa (kg/cm², psi)

Tire position	Size	Cold tire pressure
Front	P225/65R17 102H	230 (2.35, 33)
	P225/65RF17 100H	
	P225/60R18 100H	
Rear	P225/65R17 102H	
	P225/65RF17 100H	
	P225/60R18 100H	
Spare (if equipped)	T145/90D16 106M	420 (4.28, 60)
	T155/90D17 101M	