

SECTION **CHG**  
CHARGING SYSTEM

A  
B  
C  
D  
E  
F  
G  
H  
I  
J  
K  
L  
CHG  
N  
O  
P

CONTENTS

<b>BASIC INSPECTION</b> .....	2	<b>PRECAUTION</b> .....	16
<b>DIAGNOSIS AND REPAIR WORKFLOW</b> .....	2	<b>PRECAUTIONS</b> .....	16
Work Flow .....	2	<b>FOR USA AND CANADA</b> .....	16
<b>SYSTEM DESCRIPTION</b> .....	5	FOR USA AND CANADA : Precaution for Supplemental Restraint System (SRS) "AIR BAG" and "SEAT BELT PRE-TENSIONER" .....	16
<b>CHARGING SYSTEM</b> .....	5	<b>FOR MEXICO</b> .....	16
System Diagram .....	5	FOR MEXICO : Precaution for Supplemental Restraint System (SRS) "AIR BAG" and "SEAT BELT PRE-TENSIONER" .....	16
System Description .....	5	<b>PREPARATION</b> .....	18
Component Parts Location .....	5	<b>PREPARATION</b> .....	18
Component Description .....	6	Special Service Tools .....	18
<b>DTC/CIRCUIT DIAGNOSIS</b> .....	7	Commercial Service Tools .....	18
<b>B TERMINAL CIRCUIT</b> .....	7	<b>PERIODIC MAINTENANCE</b> .....	19
Description .....	7	<b>CHARGING SYSTEM PRELIMINARY INSPECTION</b> .....	19
Diagnosis Procedure .....	7	Inspection Procedure .....	19
<b>L TERMINAL CIRCUIT (OPEN)</b> .....	8	<b>REMOVAL AND INSTALLATION</b> .....	20
Description .....	8	<b>ALTERNATOR</b> .....	20
Diagnosis Procedure .....	8	Exploded View .....	20
<b>L TERMINAL CIRCUIT (SHORT)</b> .....	10	Removal and Installation .....	21
Description .....	10	Inspection .....	22
Diagnosis Procedure .....	10	<b>SERVICE DATA AND SPECIFICATIONS (SDS)</b> .....	23
<b>S TERMINAL CIRCUIT</b> .....	11	<b>SERVICE DATA AND SPECIFICATIONS (SDS)</b> .....	23
Description .....	11	Alternator .....	23
Diagnosis Procedure .....	11		
<b>CHARGING SYSTEM</b> .....	12		
Wiring Diagram - CHARGING SYSTEM - .....	12		
<b>SYMPTOM DIAGNOSIS</b> .....	15		
<b>CHARGING SYSTEM</b> .....	15		
Symptom Table .....	15		



# DIAGNOSIS AND REPAIR WORKFLOW

## < BASIC INSPECTION >

---

### NOTE:

To ensure a complete and thorough diagnosis, the battery, starter and alternator test segments must be done as a set from start to finish.

### 1. PRELIMINARY INSPECTION

---

Perform the preliminary inspection. Refer to [CHG-19, "Inspection Procedure"](#).

>> GO TO 2.

### 2. DIAGNOSIS WITH STARTING/CHARGING SYSTEM TESTER

---

Perform the charging system test using Starting/Charging System Tester (SST: J-44373). For details and operating instructions, refer to Technical Service Bulletin.

#### Test result

CHARGING SYSTEM NOMAL>>Charging system is normal and will also show "DIODE RIPPLE" test result.

NO CHARGING VOLTAGE>>GO TO 3.

LOW CHARGING VOLTAGE>>GO TO 11.

HIGH CHARGING VOLTAGE>>GO TO 13.

DIODE RIPPLE NORMAL>>Diode ripple is OK and will also show "CHARGING VOLTAGE" test result.

EXCESS RIPPLE DETECTED>>Replace the alternator. Perform "DIODE RIPPLE" test again using Starting/Charging System Tester (SST: J-44373) to confirm repair.

DIODE RIPPLE NOT DETECTED>>GO TO 4.

### 3. INSPECTION WITH CHARGE WARNING LAMP (IGNITION SWITCH IS ON)

---

Turn the ignition switch ON.

Does the charge warning lamp illuminate?

YES >> GO TO 5.

NO >> GO TO 4.

### 4. "L" TERMINAL CIRCUIT (OPEN) INSPECTION

---

Check "L" terminal circuit (open). Refer to [CHG-8, "Diagnosis Procedure"](#).

Is the "L" terminal circuit normal?

YES >> Replace alternator.

NO >> Repair as needed.

### 5. INSPECTION WITH CHARGE WARNING LAMP (IDLING)

---

Start the engine and run it at idle.

Does the charge warning lamp turn OFF?

YES >> GO TO 8.

NO >> GO TO 6.

### 6. "L" TERMINAL CIRCUIT (SHORT) INSPECTION

---

Check "L" terminal circuit (short). Refer to [CHG-10, "Diagnosis Procedure"](#).

Is the "L" terminal circuit normal?

YES >> GO TO 7.

NO >> Repair as needed.

### 7. "S" TERMINAL CIRCUIT INSPECTION

---

Check "S" terminal circuit. Refer to [CHG-11, "Diagnosis Procedure"](#).

Is the "S" terminal circuit normal?

YES >> GO TO 9.

NO >> Repair as needed.

### 8. INSPECTION WITH CHARGE WARNING LAMP (ENGINE AT 3,000 RPM)

---

Increase and maintain the engine speed at 3,000 rpm.

Does the charge warning lamp remain off?

YES >> GO TO 10.

NO >> GO TO 9.

A  
B  
C  
D  
E  
F  
G  
H  
I  
J  
K  
L

CHG

N  
O  
P

## DIAGNOSIS AND REPAIR WORKFLOW

< BASIC INSPECTION >

---

### 9. INSPECTION OF ALTERNATOR PULLEY

---

Check alternator pulley. Refer to [CHG-22, "Inspection"](#).

Is alternator pulley normal?

YES >> Replace alternator.

NO >> Repair as needed.

### 10. "B" TERMINAL CIRCUIT INSPECTION

---

Check "B" terminal circuit. Refer to [CHG-7, "Diagnosis Procedure"](#).

Is "B" terminal circuit normal?

YES >> Replace alternator.

NO >> Repair as needed.

### 11. "B" TERMINAL CIRCUIT INSPECTION

---

Check "B" terminal circuit. Refer to [CHG-7, "Diagnosis Procedure"](#).

Is "B" terminal circuit normal?

YES >> GO TO 12.

NO >> Repair as needed.

### 12. INSPECTION OF ALTERNATOR PULLEY

---

Check alternator pulley. Refer to [CHG-22, "Inspection"](#).

Is alternator pulley normal?

YES >> Replace alternator.

NO >> Repair as needed.

### 13. "S" TERMINAL CIRCUIT INSPECTION

---

Check "S" terminal circuit. Refer to [CHG-11, "Diagnosis Procedure"](#).

Is the "S" terminal circuit normal?

YES >> Replace alternator.

NO >> Repair as needed.

# CHARGING SYSTEM

< SYSTEM DESCRIPTION >

## SYSTEM DESCRIPTION

### CHARGING SYSTEM

#### System Diagram

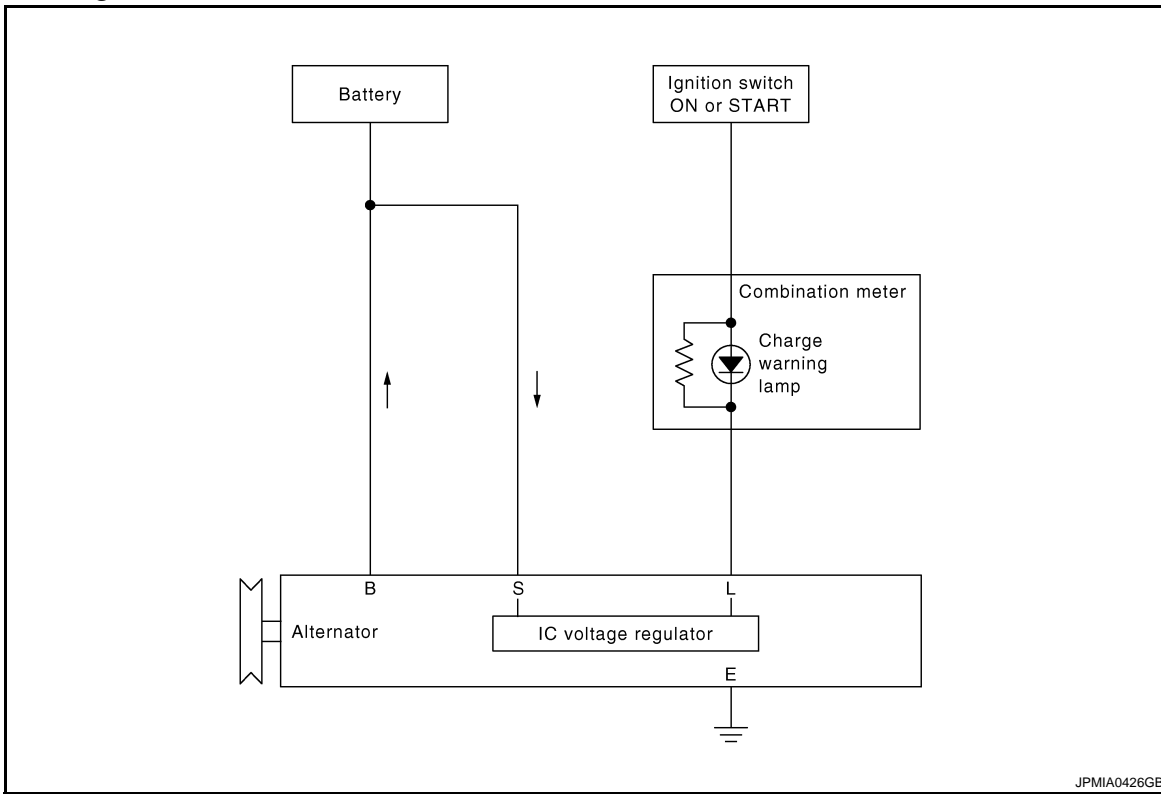

#### System Description

INFOID:000000005254929

The alternator provides DC voltage to operate the vehicle's electrical system and to keep the battery charged. The voltage output is controlled by the IC voltage regulator.

#### Component Parts Location

INFOID:000000005254930

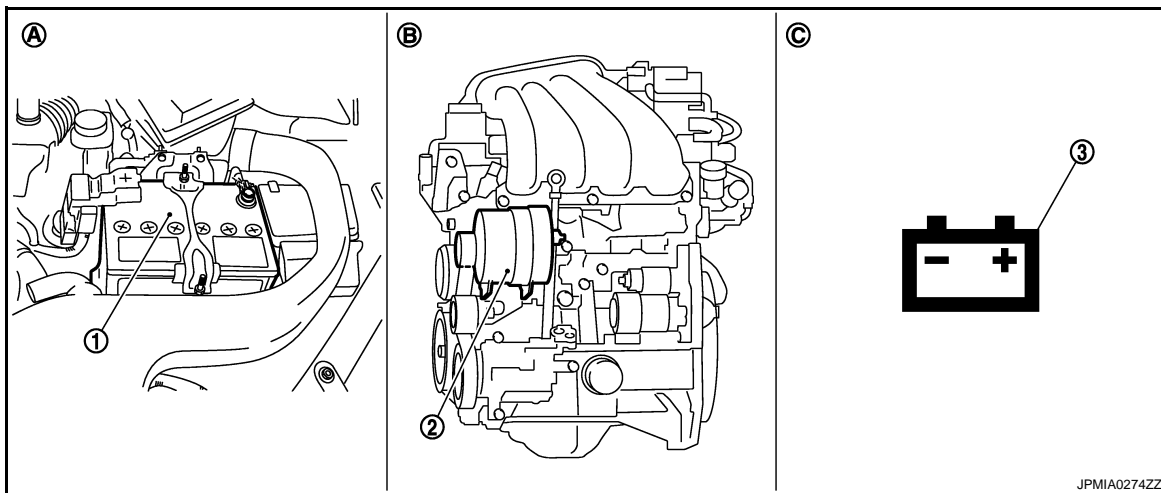

- 1. Battery
- A. Engine room (left side)

- 2. Alternator
- B. Engine

- 3. Charge warning lamp
- C. Combination meter

A  
B  
C  
D  
E  
F  
G  
H  
I  
J  
K  
L  
N  
O  
P

CHG

# CHARGING SYSTEM

< SYSTEM DESCRIPTION >

## Component Description

INFOID:000000005254931

Component part		Description
Alternator	"B" terminal	Refer to <a href="#">CHG-7, "Description"</a> .
	"S" terminal	Refer to <a href="#">CHG-11, "Description"</a> .
	"L" terminal	Refer to <a href="#">CHG-8, "Description"</a> .
Combination meter (Charge warning lamp)		The IC voltage regulator warning function activates to illuminate the charge warning lamp, if any of the following symptoms occur while alternator is operating: <ul style="list-style-type: none"><li>• Excessive voltage is produced.</li><li>• No voltage is produced.</li></ul>

# B TERMINAL CIRCUIT

< DTC/CIRCUIT DIAGNOSIS >

## DTC/CIRCUIT DIAGNOSIS

### B TERMINAL CIRCUIT

#### Description

INFOID:000000005254932

"B" terminal circuit supplies power to charge the battery and to operate the vehicle's electrical system.

#### Diagnosis Procedure

INFOID:000000005254933

#### 1. CHECK "B" TERMINAL CONNECTION

1. Turn ignition switch OFF.
2. Check if "B" terminal is clean and tight.

Is the inspection result normal?

- YES >> GO TO 2.  
NO >> Repair "B" terminal connection.

#### 2. CHECK "B" TERMINAL CIRCUIT

Check voltage between alternator "B" terminal and ground.

Terminals			Voltage (Approx.)
(+)	(-)		
Alternator "B" terminal	Terminal	Ground	Battery voltage
F59	1		

Is the inspection result normal?

- YES >> GO TO 3.  
NO >> Check harness for open between alternator and fusible link.

#### 3. CHECK "B" TERMINAL CONNECTION (VOLTAGE DROP TEST)

1. Start engine, then engine running at idle and warm.
2. Check voltage between battery positive terminal and alternator "B" terminal.

Terminals			Voltage (Approx.)
(+)	(-)		
Battery positive terminal	Alternator "B" terminal	Terminal	Less than 0.2 V
	F59	1	

Is the inspection result normal?

- YES >> "B" terminal circuit is normal. Refer to [CHG-2, "Work Flow"](#).  
NO >> Check harness between battery and alternator for poor continuity.

A  
B  
C  
D  
E  
F  
G  
H  
I  
J  
K  
L  
N  
O  
P

CHG

# L TERMINAL CIRCUIT (OPEN)

< DTC/CIRCUIT DIAGNOSIS >

## L TERMINAL CIRCUIT (OPEN)

### Description

INFOID:000000005254934

The "L" terminal circuit controls the charge warning lamp. The charge warning lamp illuminates when the ignition switch is set to ON or START. When the alternator is providing sufficient voltage with the engine running, the charge warning lamp will go off. If the charge warning lamp illuminates with the engine running, a malfunction is indicated.

### Diagnosis Procedure

INFOID:000000005254935

#### 1. CHECK "L" TERMINAL CONNECTION

1. Turn ignition switch OFF.
2. Check if "L" terminal is clean and tight.

Is the inspection result normal?

- YES >> GO TO 2.  
NO >> Repair "L" terminal connection.

#### 2. CHECK "L" TERMINAL CIRCUIT (OPEN)

1. Disconnect alternator connector.
2. Apply ground to alternator harness connector terminal.
3. Check condition of the charge warning lamp with the ignition switch in the ON position.

Alternator harness connector	Terminal	Ground	Condition	
			Ignition switch position	Charge warning lamp
F60	3		ON	Illuminate

Does it illuminate?

- YES >> "L" terminal circuit is normal. Refer to [CHG-2, "Work Flow"](#).  
NO >> GO TO 3.

#### 3. CHECK HARNESS CONTINUITY (OPEN CIRCUIT)

1. Disconnect the battery cable from the negative terminal.
2. Disconnect the combination meter connector.
3. Check continuity between alternator harness connector and combination meter harness connector.

Alternator harness connector		Combination meter harness connector		Continuity
Connector No.	Terminal No.	Connector No.	Terminal No.	
F60	3	M34	25	Existed

Is the inspection result normal?

- YES >> GO TO 4.  
NO >> Repair the harness or connector.

#### 4. CHECK HARNESS CONTINUITY (OPEN CIRCUIT)

Check continuity between combination meter harness connector M34 terminal 2 and 10A fuse [No.3, located in the fuse block (J/B)].

Does continuity exist?

- YES >> GO TO 5.  
NO >> Repair the harness.

#### 5. CHECK POWER SUPPLY CIRCUIT

1. Connect the battery cable to the negative terminal.
2. Check voltage between combination meter harness connector and ground.



## L TERMINAL CIRCUIT (OPEN)

< DTC/CIRCUIT DIAGNOSIS >

Terminals		(-)	Condition	Voltage (Approx.)
(+)				
Combination meter harness connector	Terminal			
M34	2	Ground	When the ignition switch is in ON position	Battery voltage

Is the inspection result normal?

YES >> Replace combination meter.

NO >> Inspect the power supply circuit. Refer to [PG-41, "Wiring Diagram - IGNITION POWER SUPPLY - "](#)

A  
B  
C  
D  
E  
F  
G  
H  
I  
J  
K  
L

**CHG**

N  
O  
P

# L TERMINAL CIRCUIT (SHORT)

< DTC/CIRCUIT DIAGNOSIS >

## L TERMINAL CIRCUIT (SHORT)

### Description

INFOID:000000005254936

The "L" terminal circuit controls the charge warning lamp. The charge warning lamp illuminates when the ignition switch is set to ON or START. When the alternator is providing sufficient voltage with the engine running, the charge warning lamp will go off. If the charge warning lamp illuminates with the engine running, a malfunction is indicated.

### Diagnosis Procedure

INFOID:000000005254937

#### 1. CHECK "L" TERMINAL CIRCUIT (SHORT)

1. Turn ignition switch OFF.
2. Disconnect alternator connector.
3. Turn ignition switch ON.

Does charge warning lamp illuminate?

YES >> GO TO 2.

NO >> Refer to [CHG-2. "Work Flow"](#).

#### 2. CHECK HARNESS CONTINUITY (SHORT CIRCUIT)

1. Turn the ignition switch OFF.
2. Disconnect the battery cable from the negative terminal.
3. Disconnect combination meter connector.
4. Check continuity between combination meter harness connector and ground.

Combination meter harness connector		Ground	Continuity
Connector No.	Terminal No.		
M34	25		Not existed

Is the inspection result normal?

YES >> Replace combination meter.

NO >> Repair the harness.

# S TERMINAL CIRCUIT

< DTC/CIRCUIT DIAGNOSIS >

## S TERMINAL CIRCUIT

### Description

INFOID:000000005254938

The output voltage of the alternator is controlled by the IC voltage regulator at the "S" terminal detecting the input voltage.

The "S" terminal circuit detects the battery voltage to adjust the alternator output voltage with the IC voltage regulator.

### Diagnosis Procedure

INFOID:000000005254939

#### 1. CHECK "S" TERMINAL CONNECTION

1. Turn ignition switch OFF.
2. Check if "S" terminal is clean and tight.

Is the inspection result normal?

YES >> GO TO 2.

NO >> Repair "S" terminal connection.

#### 2. CHECK "S" TERMINAL CIRCUIT

Check voltage between alternator harness connector and ground.

Terminals		Voltage (Approx.)
(+)	(-)	
Alternator harness connector	Terminal	Battery voltage
F60	4	

Is the inspection result normal?

YES >> Refer to [CHG-2, "Work Flow"](#).

NO >> Check harness for open between alternator and fuse.

A  
B  
C  
D  
E  
F  
G  
H  
I  
J  
K  
L  
N  
O  
P

CHG

# CHARGING SYSTEM

< DTC/CIRCUIT DIAGNOSIS >

## CHARGING SYSTEM

### Wiring Diagram - CHARGING SYSTEM -

INFOID:000000005254940

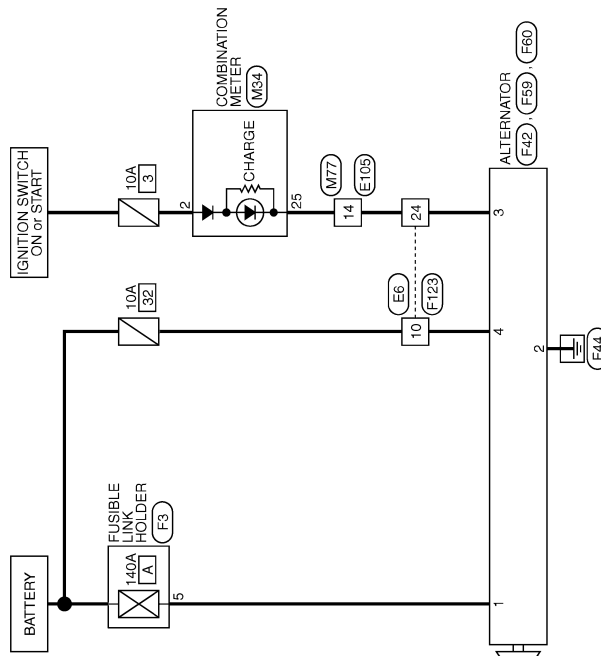

CHARGING SYSTEM

2008/07/15

JCMWM2862G

# CHARGING SYSTEM

< DTC/CIRCUIT DIAGNOSIS >

## CHARGING SYSTEM

Connector No.	E6	Connector No.	F3	Connector No.	E105	Connector No.	F42
Connector Name	WIRE TO WIRE	Connector Name	FUSIBLE LINK HOLDER	Connector Name	WIRE TO WIRE	Connector Name	ALTERNATOR
Connector Type	TK24MW-1V	Connector Type	-	Connector Type	TK8GFW-CS16-TM4	Connector Type	-
Terminal No.	10	Terminal No.	5	Terminal No.	14	Terminal No.	2
Color of Wire	LG	Color of Wire	B/R	Color of Wire	L	Color of Wire	-
Signal Name [Specification]	-	Signal Name [Specification]	-	Signal Name [Specification]	-	Signal Name [Specification]	-
Terminal No.	24	Terminal No.	5	Terminal No.	14	Terminal No.	2
Color of Wire	L	Color of Wire	B/R	Color of Wire	L	Color of Wire	-
Signal Name [Specification]	-	Signal Name [Specification]	-	Signal Name [Specification]	-	Signal Name [Specification]	-

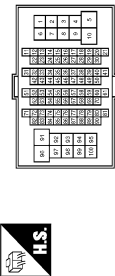

Connector No.	F59	Connector No.	F123	Connector No.	F60	Connector No.	M34
Connector Name	ALTERNATOR	Connector Name	WIRE TO WIRE	Connector Name	ALTERNATOR	Connector Name	COMBINATION METER
Connector Type	-	Connector Type	TK24FW-1V	Connector Type	X02FW	Connector Type	SAB40FW
Terminal No.	1	Terminal No.	10	Terminal No.	3	Terminal No.	2
Color of Wire	B/R	Color of Wire	P	Color of Wire	L	Color of Wire	O
Signal Name [Specification]	-	Signal Name [Specification]	-	Signal Name [Specification]	-	Signal Name [Specification]	IGN
Terminal No.	1	Terminal No.	24	Terminal No.	4	Terminal No.	25
Color of Wire	B/R	Color of Wire	L	Color of Wire	P	Color of Wire	SB
Signal Name [Specification]	-	Signal Name [Specification]	-	Signal Name [Specification]	-	Signal Name [Specification]	ALTERNATOR

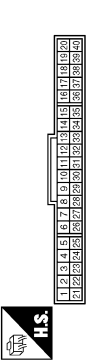
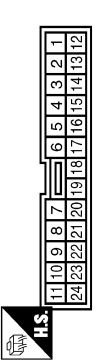

JCMWM2863G1

A  
B  
C  
D  
E  
F  
G  
H  
I  
J  
K  
L  
CHG  
N  
O  
P

# CHARGING SYSTEM

< DTC/CIRCUIT DIAGNOSIS >

**CHARGING SYSTEM**

Connector No.	M77
Connector Name	WIRE TO WIRE
Connector Type	THB0MW-C51(F-TM4)

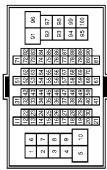
Terminal No.	Color of Wire	Signal Name [Specification]
14	SB	-

JCMWM2864G

# CHARGING SYSTEM

< SYMPTOM DIAGNOSIS >

## SYMPTOM DIAGNOSIS

### CHARGING SYSTEM

#### Symptom Table

INFOID:000000005254941

Symptom	Reference
Discharged battery	Refer to <a href="#">CHG-2, "Work Flow"</a> .
The charge warning lamp does not illuminate when the ignition switch is set to ON.	
The charge warning lamp does not turn OFF after the engine starts.	
The charge warning lamp turns ON when increasing the engine speed.	

A  
B  
C  
D  
E  
F  
G  
H  
I  
J  
K  
L  
N  
O  
P

**CHG**

# PRECAUTIONS

< PRECAUTION >

## PRECAUTION

### PRECAUTIONS

#### FOR USA AND CANADA

FOR USA AND CANADA : Precaution for Supplemental Restraint System (SRS) "AIR BAG" and "SEAT BELT PRE-TENSIONER"

INFOID:000000005254942

The Supplemental Restraint System such as "AIR BAG" and "SEAT BELT PRE-TENSIONER", used along with a front seat belt, helps to reduce the risk or severity of injury to the driver and front passenger for certain types of collision. This system includes seat belt switch inputs and dual stage front air bag modules. The SRS system uses the seat belt switches to determine the front air bag deployment, and may only deploy one front air bag, depending on the severity of a collision and whether the front occupants are belted or unbelted.

Information necessary to service the system safely is included in the "SRS AIR BAG" and "SEAT BELT" of this Service Manual.

#### **WARNING:**

- To avoid rendering the SRS inoperative, which could increase the risk of personal injury or death in the event of a collision which would result in air bag inflation, all maintenance must be performed by an authorized NISSAN/INFINITI dealer.
- Improper maintenance, including incorrect removal and installation of the SRS, can lead to personal injury caused by unintentional activation of the system. For removal of Spiral Cable and Air Bag Module, see the "SRS AIR BAG".
- Do not use electrical test equipment on any circuit related to the SRS unless instructed to in this Service Manual. SRS wiring harnesses can be identified by yellow and/or orange harnesses or harness connectors.

#### PRECAUTIONS WHEN USING POWER TOOLS (AIR OR ELECTRIC) AND HAMMERS

#### **WARNING:**

- When working near the Air Bag Diagnosis Sensor Unit or other Air Bag System sensors with the ignition ON or engine running, DO NOT use air or electric power tools or strike near the sensor(s) with a hammer. Heavy vibration could activate the sensor(s) and deploy the air bag(s), possibly causing serious injury.
- When using air or electric power tools or hammers, always switch the ignition OFF, disconnect the battery, and wait at least 3 minutes before performing any service.

#### FOR MEXICO

FOR MEXICO : Precaution for Supplemental Restraint System (SRS) "AIR BAG" and "SEAT BELT PRE-TENSIONER"

INFOID:000000005254943

The Supplemental Restraint System such as "AIR BAG" and "SEAT BELT PRE-TENSIONER", used along with a front seat belt, helps to reduce the risk or severity of injury to the driver and front passenger for certain types of collision. Information necessary to service the system safely is included in the "SRS AIR BAG" and "SEAT BELT" of this Service Manual.

#### **WARNING:**

- To avoid rendering the SRS inoperative, which could increase the risk of personal injury or death in the event of a collision which would result in air bag inflation, all maintenance must be performed by an authorized NISSAN/INFINITI dealer.
- Improper maintenance, including incorrect removal and installation of the SRS, can lead to personal injury caused by unintentional activation of the system. For removal of Spiral Cable and Air Bag Module, see the "SRS AIR BAG".
- Do not use electrical test equipment on any circuit related to the SRS unless instructed to in this Service Manual. SRS wiring harnesses can be identified by yellow and/or orange harnesses or harness connectors.

#### PRECAUTIONS WHEN USING POWER TOOLS (AIR OR ELECTRIC) AND HAMMERS

#### **WARNING:**

- When working near the Air Bag Diagnosis Sensor Unit or other Air Bag System sensors with the ignition ON or engine running, DO NOT use air or electric power tools or strike near the sensor(s)



## PRECAUTIONS

### < PRECAUTION >

---

- with a hammer. Heavy vibration could activate the sensor(s) and deploy the air bag(s), possibly causing serious injury.
- When using air or electric power tools or hammers, always switch the ignition OFF, disconnect the battery, and wait at least 3 minutes before performing any service.

A

B

C

D

E

F

G

H

I

J

K

L

CHG

N

O

P

# PREPARATION

< PREPARATION >

## PREPARATION

### PREPARATION

#### Special Service Tools

INFOID:000000005254944

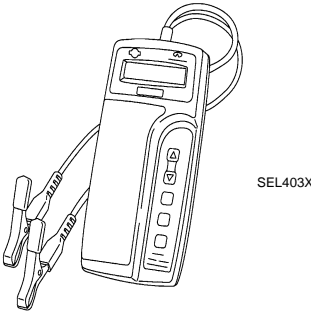
Tool number (Kent-Moore No.) Tool name	Description
<p>— (J-44373 Model MCR620) Starting/Charging System Tester</p>  <p>SEL403X</p>	<p>Tests starting and charging systems. For operating instructions, refer to Technical Service Bulletin.</p>

#### Commercial Service Tools

INFOID:000000005254945

Tool name	Description
<p>Power tool</p>  <p>PIIB1407E</p>	<p>Loosening bolts, nuts and screws</p>

# CHARGING SYSTEM PRELIMINARY INSPECTION

< PERIODIC MAINTENANCE >

## PERIODIC MAINTENANCE

### CHARGING SYSTEM PRELIMINARY INSPECTION

#### Inspection Procedure

INFOID:000000005254946

#### 1. CHECK BATTERY TERMINALS CONNECTION

Check if battery terminals are clean and tight.

Is the inspection result normal?

YES >> GO TO 2.

NO >> Repair battery terminals connection.

#### 2. CHECK FUSE

Check for blown fuse.

Unit	Power source (Power supply terminals)	Fuse No.
Alternator	Battery ("S" terminal)	32
Combination meter	Ignition switch ON ("L" terminal)	3

Is the inspection result normal?

YES >> GO TO 3.

NO >> Be sure to eliminate the cause of malfunction before installing new fuse.

#### 3. CHECK "E" TERMINAL CONNECTION

Check if "E" terminal (alternator ground harness) is clean and tight.

Is the inspection result normal?

YES >> GO TO 4.

NO >> Repair "E" terminal connection.

#### 4. CHECK DRIVE BELT TENSION

Check drive belt tension. Refer to [EM-16. "Checking"](#).

Is the inspection result normal?

YES >> INSPECTION END

NO >> Repair as needed.

A  
B  
C  
D  
E  
F  
G  
H  
I  
J  
K  
L  
N  
O  
P

CHG

# ALTERNATOR

< REMOVAL AND INSTALLATION >

## REMOVAL AND INSTALLATION

### ALTERNATOR

Exploded View

INFOID:000000005254947

#### REMOVAL

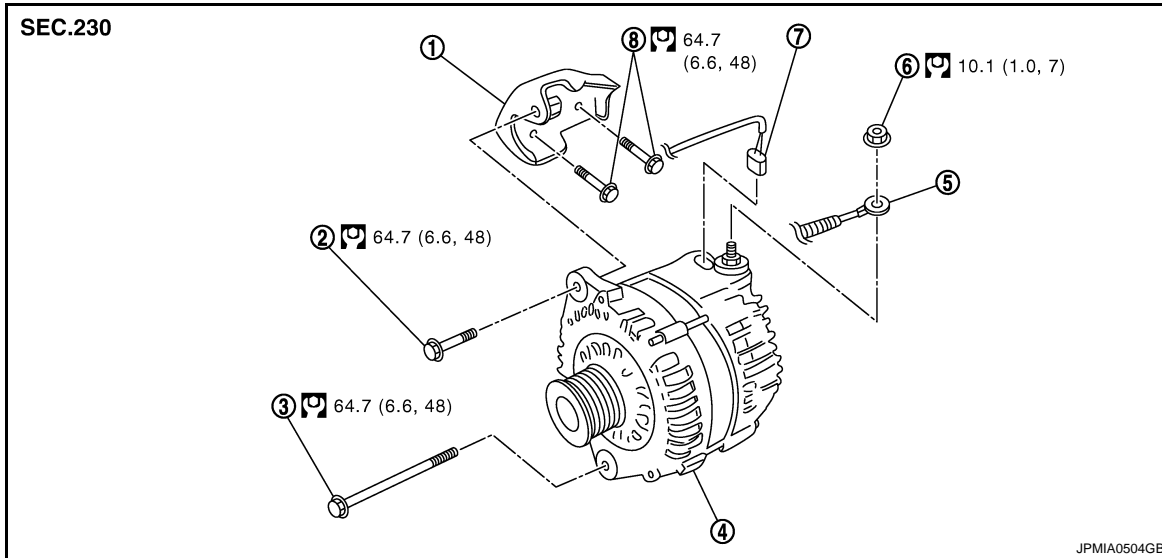

1. Alternator bracket
2. Upper alternator mounting bolt
3. Lower alternator mounting bolt
4. Alternator
5. "B" terminal harness
6. "B" terminal nut
7. Alternator connector
8. Alternator bracket mounting bolts

Refer to [GI-4, "Components"](#) for symbols in the figure.

#### DISASSEMBLY

Type: LR1110-713C

# ALTERNATOR

## < REMOVAL AND INSTALLATION >

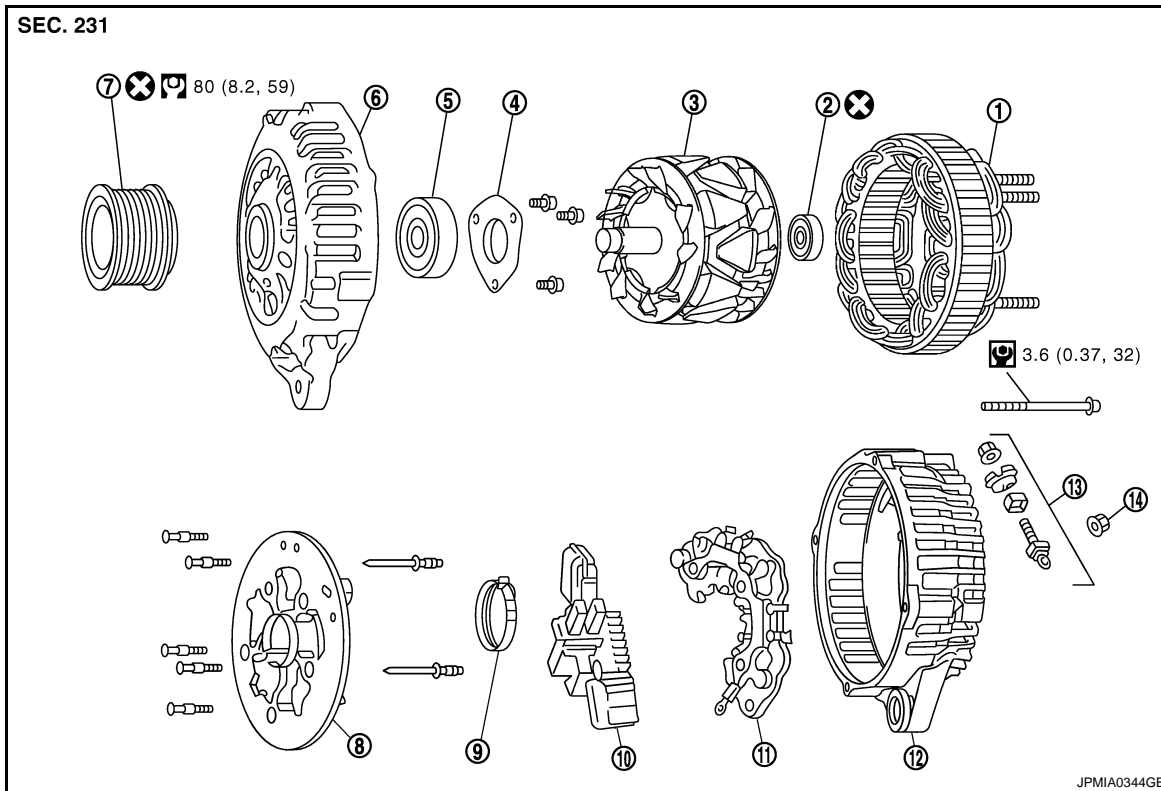

- |                                   |                      |                   |
|-----------------------------------|----------------------|-------------------|
| 1. Stator                         | 2. Rear bearing      | 3. Rotor          |
| 4. Retainer                       | 5. Front bearing     | 6. Front cover    |
| 7. Pulley                         | 8. Fan guide         | 9. Labyrinth seal |
| 10. IC voltage regulator assembly | 11. Diode assembly   | 12. Rear cover    |
| 13. Terminal assembly             | 14. "B" terminal nut |                   |

Refer to [GI-4, "Components"](#) for symbols in the figure.

## Removal and Installation

INFOID:000000005254948

### REMOVAL

1. Disconnect the battery cable from the negative terminal.
2. Remove drive belt. Refer to [EM-16, "Exploded View"](#).
3. Disconnect alternator connector (A).
4. Remove "B" terminal nut (B) and "B" terminal harness.
5. Remove harness bracket (C).
6. Remove upper alternator mounting bolt (D), using power tools.
7. Remove lower alternator mounting bolt (E), using power tools.

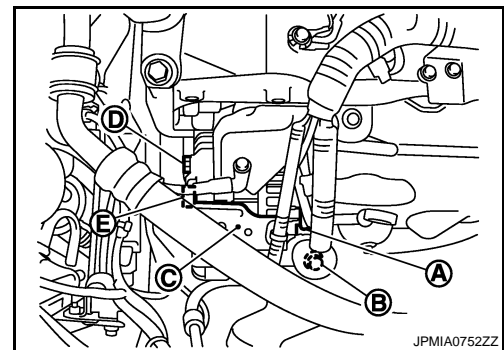

8. Remove alternator upward from the vehicle.

### INSTALLATION

Note the following, and installation is the reverse order of removal.

- Install alternator, and check tension of belt. Refer to [EM-16, "Checking"](#).

#### **CAUTION:**

**Be sure to tighten "B" terminal nut carefully.**

# ALTERNATOR

< REMOVAL AND INSTALLATION >

---

## Inspection

INFOID:000000005254949

### ALTERNATOR PULLEY INSPECTION

Perform the following.

- Make sure that alternator pulley does not rattle.
- Make sure that alternator pulley is tight. Refer to [CHG-20. "Exploded View"](#).

# SERVICE DATA AND SPECIFICATIONS (SDS)

< SERVICE DATA AND SPECIFICATIONS (SDS)

## SERVICE DATA AND SPECIFICATIONS (SDS)

### SERVICE DATA AND SPECIFICATIONS (SDS)

#### Alternator

INFOID:000000005254950

Applied model		QR25DE
Type		LR1110-713
		HITACHI make
Nominal rating	[V - A]	12 - 110
Ground polarity		Negative
Minimum revolution under no-load (When 13.5 V is applied)	[rpm]	Less than 1,100
Hot output current (When 13.5 V is applied)	[A/rpm]	More than 70/1,800 More than 91/2,500 More than 110/5,000
Regulated output voltage	[V]	14.1 - 14.7
Minimum length of brush	[mm (in)]	More than 6.00 (0.236)
Brush spring pressure	[N (g, oz)]	1.00 - 3.43 (102 - 350, 3.60 - 12.34)
Slip ring minimum outer diameter	[mm (in)]	More than 26.0 (1.024)
Rotor (Field coil) resistance	[ $\Omega$ ]	2.16 - 2.46

A  
B  
C  
D  
E  
F  
G  
H  
I  
J  
K  
L

CHG

N  
O  
P