

A
LU

SECTION LU

ENGINE LUBRICATION SYSTEM

C

CONTENTS

D
E

SYSTEM DESCRIPTION	REMOVAL AND INSTALLATION	F
DESCRIPTION	OIL COOLER	G
Engine Lubrication System	Exploded View	9
Engine Lubrication System Schematic	Removal and Installation	9
PRECAUTION	Inspection	9
PRECAUTIONS	UNIT DISASSEMBLY AND ASSEMBLY ...	H
Liquid Gasket	OIL PUMP	I
PREPARATION	Exploded View	11
PREPARATION	Removal and Installation	11
Special Service Tools	Disassembly and Assembly	11
Commercial Service Tools	Inspection	12
PERIODIC MAINTENANCE	SERVICE DATA AND SPECIFICATIONS	J
ENGINE OIL	(SDS)	K
Inspection	SERVICE DATA AND SPECIFICATIONS	L
Draining	(SDS)	14
Refilling	Periodical Maintenance Specification	14
OIL FILTER	Engine Oil Pressure	14
Removal and Installation	Oil Pump	14
Inspection	Regulator Valve	14

M
N
O
P

DESCRIPTION

< SYSTEM DESCRIPTION >

SYSTEM DESCRIPTION

DESCRIPTION

Engine Lubrication System

INFOID:000000005254494

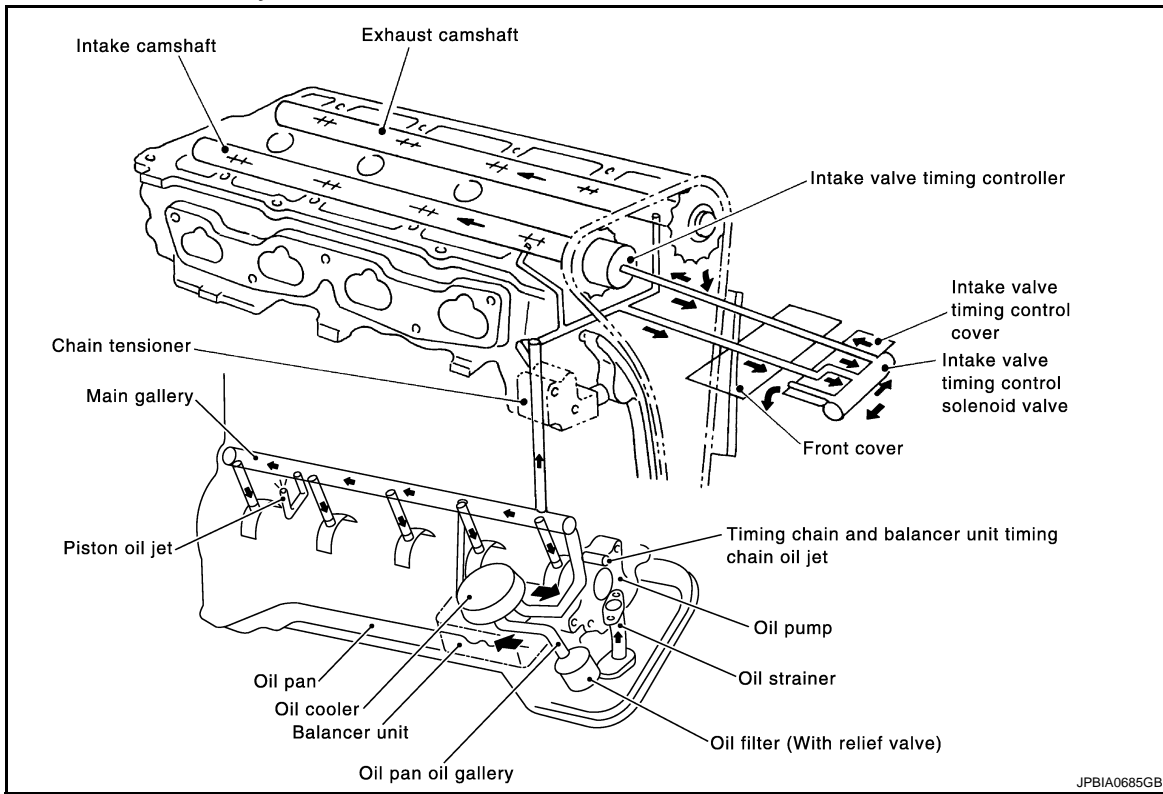

JPBIA0685GB

Engine Lubrication System Schematic

INFOID:000000005254495

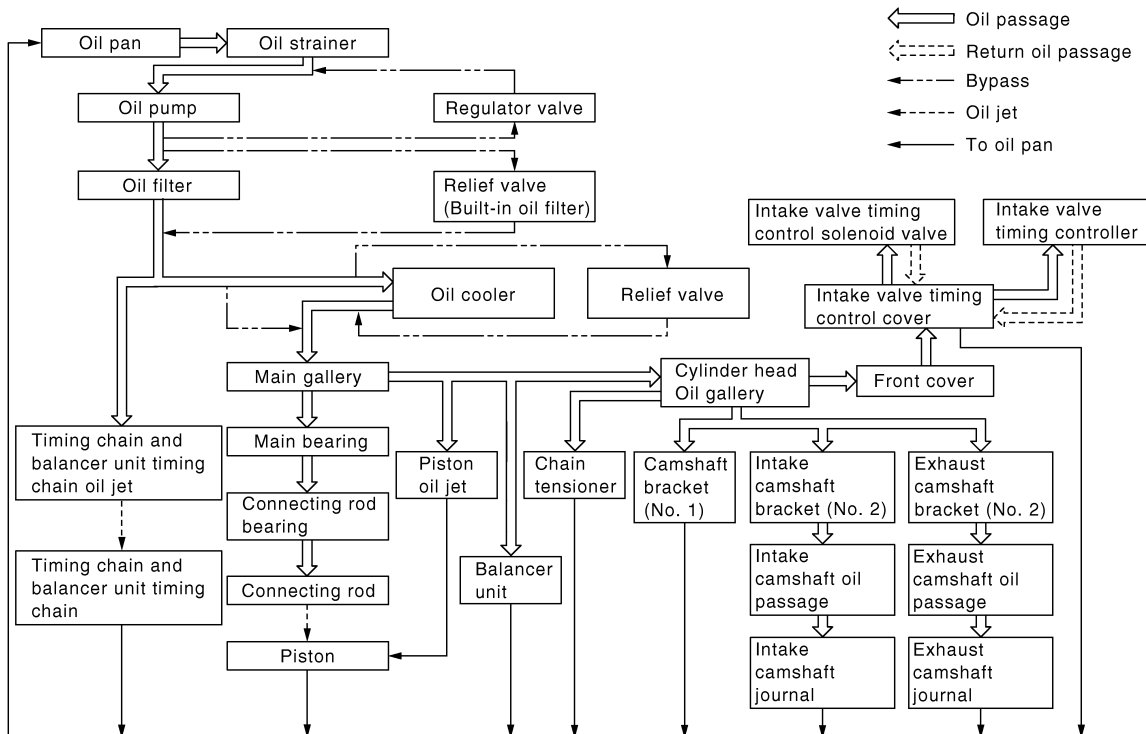

JPBIA0818GB

PRECAUTIONS

< PRECAUTION >

PRECAUTION

PRECAUTIONS

Liquid Gasket

INFOID:000000005254496

A

LU

LIQUID GASKET APPLICATION PROCEDURE

1. Remove old liquid gasket adhering to the liquid gasket application surface and the mating surface.
 - Remove liquid gasket completely from the liquid gasket application surface, mounting bolts, and bolt holes.
2. Wipe the liquid gasket application surface and the mating surface with white gasoline (lighting and heating use) to remove adhering moisture, grease and foreign materials.
3. Apply liquid gasket to the liquid gasket application surface.
Use Genuine RTV Silicone Sealant or equivalent. Refer to [GI-18. "Recommended Chemical Products and Sealants"](#).
 - Within five minutes of liquid gasket application, install the mating component.
 - If liquid gasket protrudes, wipe it off immediately.
 - Do not retighten mounting bolts or nuts after the installation.
 - After 30 minutes or more have passed from the installation, fill engine oil and engine coolant.

C

D

E

F

G

H

I

J

K

L

M

N

O

P

PREPARATION

< PREPARATION >

PREPARATION

PREPARATION

Special Service Tools

INFOID:000000005254497

Tool number (Kent-Moore No.) Tool name	Description
ST25051001 (J-25695-1) Oil pressure gauge	Measuring oil pressure Maximum measuring range: 2,452 kPa (25 kg/cm², 356 psi)
ST25052000 (J-25695-2) Hose	Adapting oil pressure gauge to oil pan (upper)
KV10115801 (J-38956) Oil filter wrench	Removing and installing oil filter a: 64.3 mm (2.531 in)

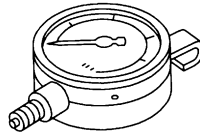

NT050

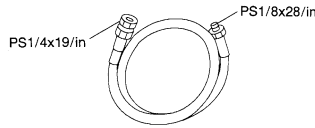

S-NT559

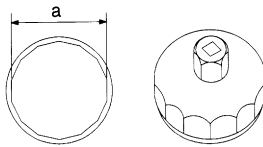

S-NT375

Commercial Service Tools

INFOID:000000005254498

Tool name	Description
Deep socket	Removing and installing oil pressure switch 27 mm (1.06 in)
Tube presser	Pressing tube of liquid gasket

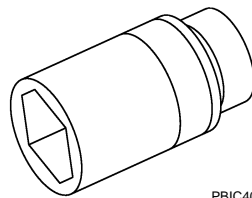

PBIC4066E

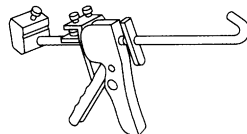

NT052

ENGINE OIL

< PERIODIC MAINTENANCE >

PERIODIC MAINTENANCE

ENGINE OIL

Inspection

INFOID:000000005254499

A

LU

ENGINE OIL LEVEL

NOTE:

Before starting engine, put vehicle horizontally and check the engine oil level. If engine is already started, stop it and allow 10 minutes before checking.

1. Pull out oil level gauge and wipe it clean.
2. Insert oil level gauge and check the engine oil level is within the range (A) shown in the figure.
3. If it is out of range, adjust it.

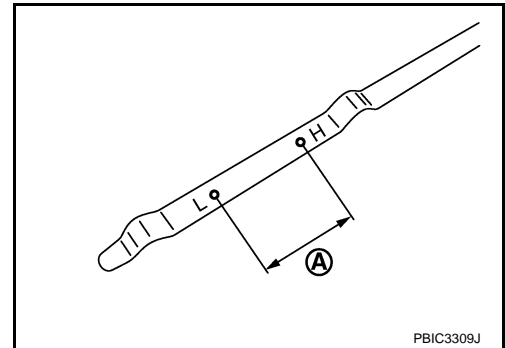

C

D

E

F

G

ENGINE OIL APPEARANCE

- Check engine oil for white turbidity or heavy contamination.
- If engine oil becomes turbid and white, it is highly probable that it is contaminated with engine coolant. Repair or replace damaged parts.

H

ENGINE OIL LEAKAGE

Check for engine oil leakage around the following areas:

- Oil pans (lower and upper)
- Oil pan drain plug
- Oil pressure switch
- Oil filter
- Oil cooler
- Intake valve timing control cover and intake valve timing control solenoid valve
- Front cover
- Mating surface between cylinder head and rocker cover
- Mating surface between cylinder block and lower cylinder block
- Mating surface between cylinder block and cylinder head
- Crankshaft oil seals (front and rear)

I

J

K

L

OIL PRESSURE CHECK

WARNING:

- **Be careful not to get burn yourself, as engine oil may be hot.**
- **When checking engine oil pressure, shift position should be "Parking", and apply parking brake securely.**

M

N

1. Check the engine oil level.
2. Remove engine under cover with power tool.

O

P

ENGINE OIL

< PERIODIC MAINTENANCE >

3. Disconnect harness connector at oil pressure switch (1), and remove oil pressure switch using deep socket (commercial service tool).

- 2 : Oil cooler
⇐ : Engine front

CAUTION:
Never drop or shock oil pressure switch.

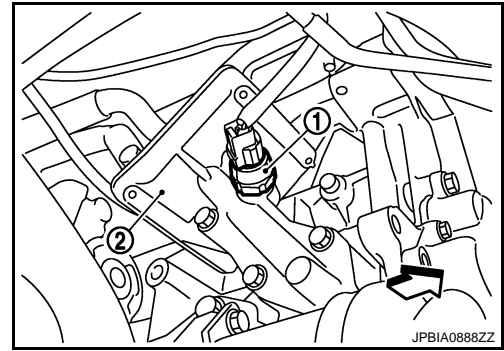

4. Install the oil pressure gauge [SST: ST25051001 (J-25695-1)] (A) and hose [SST: ST25052000 (J-25695-2)] (B).

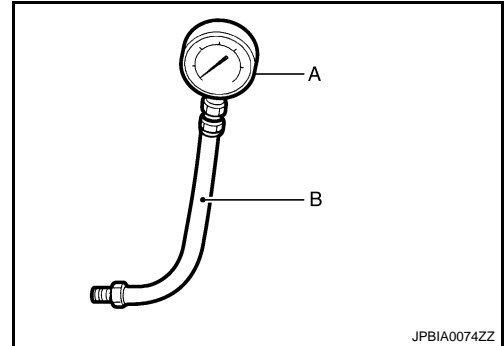

5. Start the engine and warm it up to normal operating temperature.
6. Check the engine oil pressure with engine running under no-load.

NOTE:
When the engine oil temperature is low, the engine oil pressure becomes high.

Engine oil pressure : Refer to [LU-14, "Engine Oil Pressure"](#).

If difference is extreme, check engine oil passage and oil pump for engine oil leakage.

7. After the inspections, install oil pressure switch as follows:
 - a. Remove old liquid gasket adhering to oil pressure switch and the mating surface.
 - b. Apply liquid gasket and tighten oil pressure switch to the specification.
Use Genuine RTV Silicone Sealant or equivalent. Refer to [GI-18, "Recommended Chemical Products and Sealants"](#).

Tightening torque : Refer to [LU-9, "Exploded View"](#).

- c. After warming up engine, check that there is no leakage of engine oil with running engine.

Draining

INFOID:000000005254500

WARNING:

- Be careful not to get burn yourself, as engine oil may be hot.
 - Prolonged and repeated contact with used engine oil may cause skin cancer. Try to avoid direct skin contact with used engine oil. If skin contact is made, wash thoroughly with soap or hand cleaner as soon as possible.
1. Warm up the engine, and check for engine oil leakage from engine components. Refer to [LU-5, "Inspection"](#).
 2. Stop the engine and wait for 10 minutes.
 3. Loosen oil filler cap.

ENGINE OIL

< PERIODIC MAINTENANCE >

4. Remove drain plug (1) and then drain engine oil.

← : Vehicle front

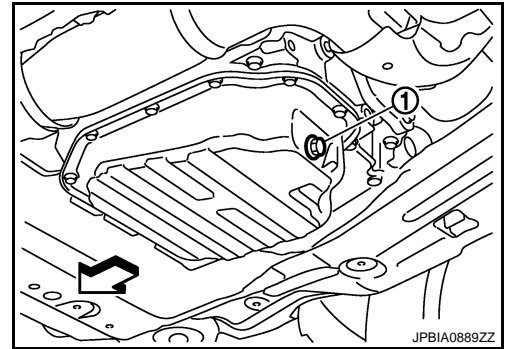

Refilling

INFOID:000000005254501

1. Install drain plug with new drain plug washer. Refer to [EM-35, "Exploded View"](#).

CAUTION:

Be sure to clean drain plug and install with new drain plug washer.

Tightening torque : Refer to [EM-35, "Exploded View"](#).

2. Refill with new engine oil.

Engine oil specification and viscosity: Refer to [MA-14, "FOR NORTH AMERICA : Fluids and Lubricants"](#) (Except for Mexico) or [MA-15, "FOR MEXICO : Fluids and Lubricants"](#) (for Mexico).

Engine oil capacity : Refer to [LU-14, "Periodical Maintenance Specification"](#).

CAUTION:

- The refill capacity depends on the engine oil temperature and drain time. Use these specifications for reference only.
 - Always use oil level gauge to determine the proper amount of engine oil in engine.
3. Warm up the engine and check area around drain plug and oil filter for engine oil leakage.
 4. Stop the engine and wait for 10 minutes.
 5. Check the engine oil level. Refer to [LU-5, "Inspection"](#).

OIL FILTER

< PERIODIC MAINTENANCE >

OIL FILTER

Removal and Installation

INFOID:000000005254502

REMOVAL

1. Remove splash guard. Refer to [EXT-22. "Exploded View"](#).
2. Using oil filter wrench [SST: KV10115801 (J-38956)] (A), remove oil filter.

↶ : Vehicle front

CAUTION:

- Oil filter is provided with relief valve. Use genuine NISSAN oil filter or equivalent.
- Be careful not to get burned when engine and engine oil may be hot.
- When removing, prepare a shop cloth to absorb any engine oil leakage or spillage.
- Never allow engine oil to adhere to drive belt.
- Completely wipe off any engine oil that adheres to engine and vehicle.

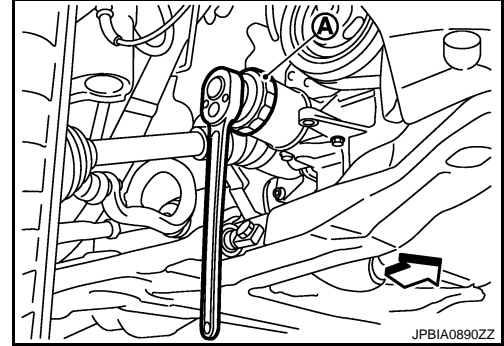

INSTALLATION

1. Remove foreign materials adhering to oil filter installation surface.
2. Apply new engine oil to the oil seal contact surface of new oil filter.

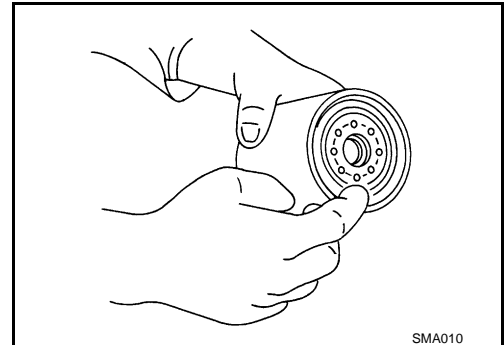

3. Screw oil filter manually until it touches the installation surface, then tighten it by 2/3 turn (A). Or tighten to the specification.

Oil filter:

 : 17.6 N·m (1.8 kg-m, 13 ft-lb)

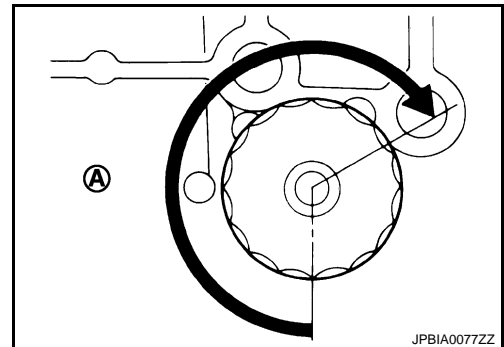

Inspection

INFOID:000000005254503

INSPECTION AFTER INSTALLATION

1. Check the engine oil level. Refer to [LU-5. "Inspection"](#).
2. Start the engine, and check there is no leakage of engine oil.
3. Stop the engine and wait for 10 minutes.
4. Check the engine oil level, and adjust the level. Refer to [LU-5. "Inspection"](#).

OIL COOLER

< REMOVAL AND INSTALLATION >

REMOVAL AND INSTALLATION

OIL COOLER

Exploded View

INFOID:000000005254504

LU

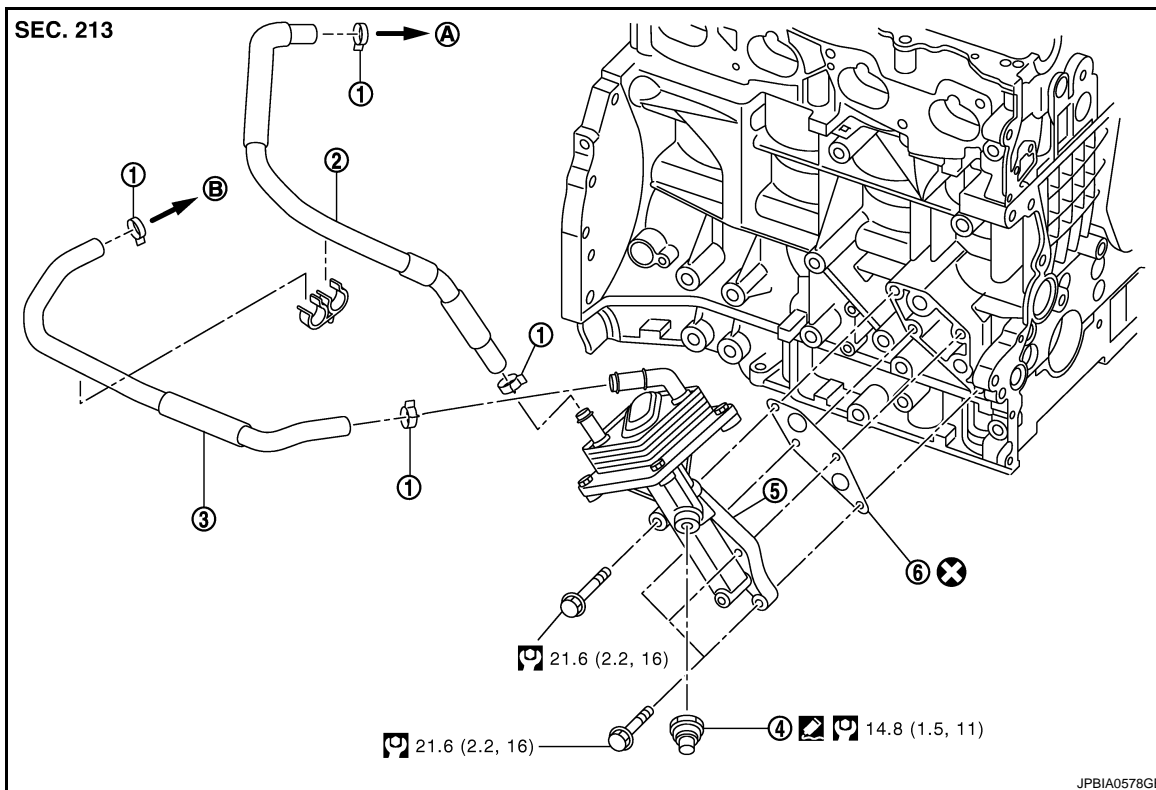

- | | | |
|------------------------|-------------------|---------------|
| 1. Clamp | 2. Water hose | 3. Water hose |
| 4. Oil pressure switch | 5. Oil cooler | 6. Gasket |
| A. To water outlet | B. To heater pipe | |

Refer to [GI-4, "Components"](#) for symbols in the figure.

Removal and Installation

INFOID:000000005254505

REMOVAL

WARNING:

Be careful not to get burn yourself, as engine oil and engine coolant may be hot.

1. Remove RH front road wheel and tire.
2. Drain engine coolant by removing water drain plug on cylinder block and radiator drain plug. Refer to [EM-89, "Exploded View"](#) and [CO-16, "Exploded View"](#).
3. Remove oil cooler mounting bolts.
4. Disconnect water hoses from oil cooler.
5. Remove oil cooler.

INSTALLATION

Install in the reverse order of removal.

Inspection

INFOID:000000005254506

INSPECTION AFTER REMOVAL

Oil Cooler

OIL COOLER

< REMOVAL AND INSTALLATION >

Check oil cooler for cracks. Check oil cooler for clogging by blowing through engine coolant inlet. If necessary, replace oil cooler.

INSPECTION AFTER INSTALLATION

1. Check the engine oil level and the engine coolant level and add engine oil and engine coolant. Refer to [LU-5. "Inspection"](#) and [CO-10. "Inspection"](#).
2. Start the engine, and check that there is no leakage of engine oil or engine coolant.
3. Stop the engine and wait for 10 minutes.
4. Check the engine oil level and the engine coolant level again. Refer to [LU-5. "Inspection"](#) and [CO-10. "Inspection"](#).

OIL PUMP

< UNIT DISASSEMBLY AND ASSEMBLY >

UNIT DISASSEMBLY AND ASSEMBLY

OIL PUMP

Exploded View

INFOID:000000005254507

A

LU

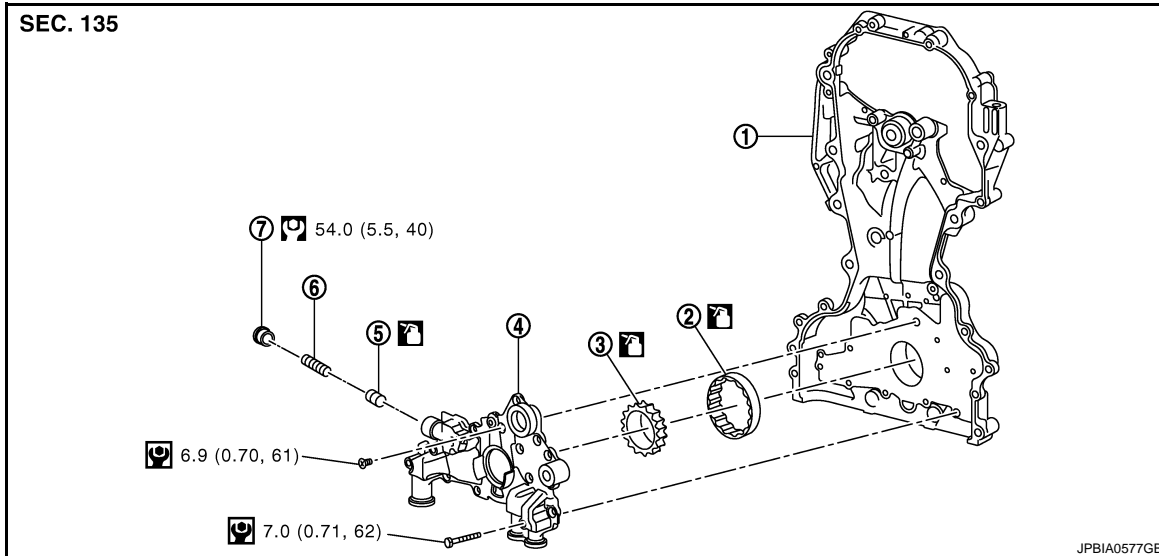

C

D

E

F

G

H

- | | | |
|---------------------------------------|--------------------|---------------------------|
| 1. Front cover (Oil pump body united) | 2. Outer rotor | 3. Inner rotor |
| 4. Oil pump cover | 5. Regulator valve | 6. Regulator valve spring |
| 7. Regulator valve plug | | |

Refer to [GI-4, "Components"](#) for symbols in the figure.

I

Removal and Installation

INFOID:000000005254508

REMOVAL

Remove front cover. Refer to [EM-70, "Exploded View"](#).

NOTE:

Oil pump is built into front cover.

INSTALLATION

Note the following, and install in the reverse order of removal.

- When installing, align crankshaft flat faces with inner rotor flat faces.

J

K

L

Disassembly and Assembly

INFOID:000000005254509

M

DISASSEMBLY

1. Remove oil pump cover.
2. Remove oil pump inner rotor and oil pump outer rotor from front cover.
3. After removing regulator valve plug, remove regulator valve spring and regulator valve.

N

O

ASSEMBLY

Note the following, and assemble in the reverse order of disassembly.

P

OIL PUMP

< UNIT DISASSEMBLY AND ASSEMBLY >

- Install oil pump inner rotor with the groove faced to oil pump cover side.

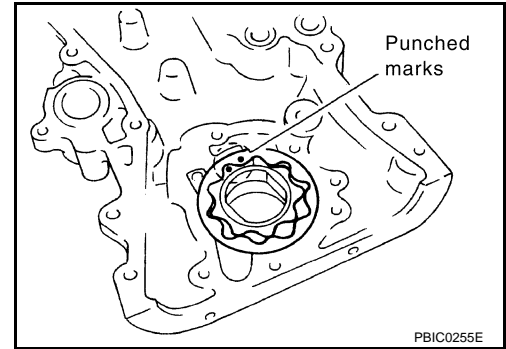

Inspection

INFOID:000000005254510

INSPECTION AFTER DISASSEMBLY

Oil Pump Clearance

- Measure the clearance with feeler gauge.
 - Clearance between outer rotor and front cover (Position "1")

Standard : Refer to [LU-14, "Oil Pump"](#).

- Tip clearance between inner rotor and outer rotor (Position "2")

Standard : Refer to [LU-14, "Oil Pump"](#).

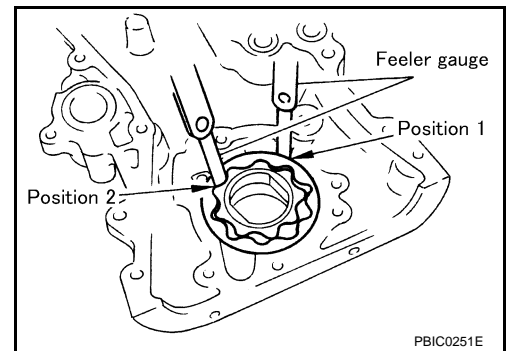

- Measure the clearance with feeler gauge and straightedge.
 - Side clearance between inner rotor and front cover (Position "3")

Standard : Refer to [LU-14, "Oil Pump"](#).

- Side clearance between outer rotor and front cover (Position "4")

Standard : Refer to [LU-14, "Oil Pump"](#).

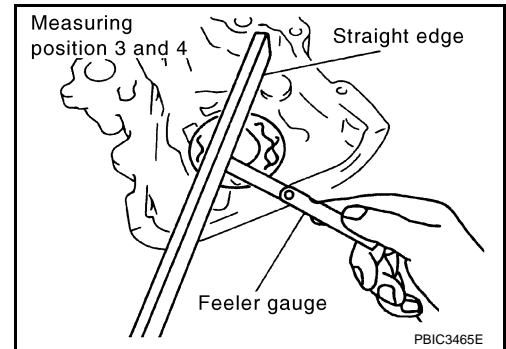

- Calculate the clearance between oil pump inner rotor and oil pump body as follows:

FRONT COVER INNER DIAMETER

- Measure the outer diameter of protruded portion of inner rotor with micrometer. (Position "5")

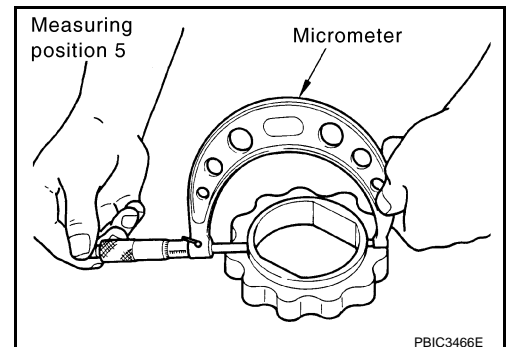

OIL PUMP INNER ROTOR OUTER DIAMETER

OIL PUMP

< UNIT DISASSEMBLY AND ASSEMBLY >

- Measure the inner diameter of front cover with inside micrometer.
(Position "6")

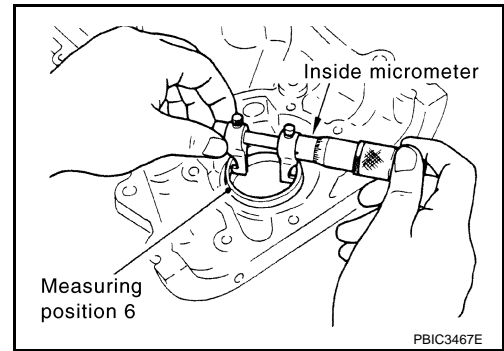

OIL PUMP INNER ROTOR TO FRONT COVER CLEARANCE

- (Clearance) = (Front cover inner diameter) – (Oil pump inner rotor outer diameter)

Standard : Refer to [LU-14, "Oil Pump"](#).

- If measured/calculated values are out of the standard, replace front cover.

Regulator Valve Clearance

- (Clearance) = (Regulator valve hole diameter) – (Regulator valve outer diameter)

Standard : Refer to [LU-14, "Regulator Valve"](#).

- If the calculated value is out of the standard, replace front cover.

CAUTION:

- Coat regulator valve with engine oil.
- Check that it falls smoothly into valve hole by its own weight.

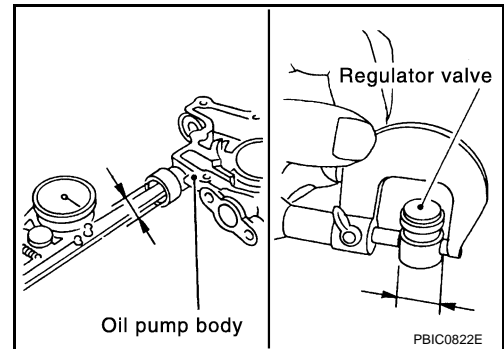

INSPECTION AFTER INSTALLATION

1. Check the engine oil level. Refer to [LU-5, "Inspection"](#).
2. Start the engine, and check that there is no leakage of engine oil.
3. Stop the engine and wait for 10 minutes.
4. Check the engine oil level and adjust the level. Refer to [LU-5, "Inspection"](#).

SERVICE DATA AND SPECIFICATIONS (SDS)

< SERVICE DATA AND SPECIFICATIONS (SDS)

SERVICE DATA AND SPECIFICATIONS (SDS)

SERVICE DATA AND SPECIFICATIONS (SDS)

Periodical Maintenance Specification

INFOID:000000005254511

ENGINE OIL CAPACITY (APPROXIMATE)

Unit: ℓ (US qt, Imp qt)

Drain and refill	With oil filter change	4.6 (4-7/8, 4)
	Without oil filter change	4.3 (4-1/2, 3/4)
Dry engine (Overhaul)		5.4 (5-3/4, 4-3/4)

Engine Oil Pressure

INFOID:000000005254512

Unit: kPa (kg/cm², psi)

Engine speed	Approximate discharge pressure*
Idle speed	More than 98 (1.0, 14)
2,000 rpm	More than 294 (3.0, 43)

*: Engine oil temperature at 80°C (176°F)

Oil Pump

INFOID:000000005254513

Unit: mm (in)

Clearance between outer rotor and front cover	0.114 - 0.179 (0.0045 - 0.0070)
Tip clearance between inner rotor and outer rotor	0.170 - 0.220 (0.0067 - 0.0087)
Side clearance between inner rotor and front cover	0.030 - 0.070 (0.0012 - 0.0028)
Side clearance between outer rotor and front cover	0.060 - 0.110 (0.0024 - 0.0043)
Oil pump inner rotor to front cover clearance	0.045 - 0.091 (0.0018 - 0.0036)

Regulator Valve

INFOID:000000005254514

Unit: mm (in)

Regulator valve to oil pump cover clearance	0.040 - 0.097 (0.0016 - 0.0038)
---	---------------------------------