

SECTION **RAX**
REAR AXLE

A
B
C

RAX

CONTENTS

E

2WD	PRECAUTION	9	F
SYMPTOM DIAGNOSIS	PRECAUTIONS	9	G
NOISE, VIBRATION AND HARSHNESS (NVH) TROUBLESHOOTING	Precautions for Drive Shaft	9	
NVH Troubleshooting Chart	PREPARATION	10	H
PREPARATION	PREPARATION	10	I
PREPARATION	Special Service Tool	10	
Commercial Service Tool	Commercial Service Tool	10	
PERIODIC MAINTENANCE	PERIODIC MAINTENANCE	11	J
REAR WHEEL HUB AND HOUSING	REAR WHEEL HUB AND HOUSING	11	K
Inspection	Inspection	11	
REMOVAL AND INSTALLATION	REAR DRIVE SHAFT	12	L
REAR WHEEL HUB	Inspection	12	M
Exploded View	REMOVAL AND INSTALLATION	13	
Removal and Installation	REAR WHEEL HUB AND HOUSING	13	N
Inspection	Exploded View	13	
SERVICE DATA AND SPECIFICATIONS (SDS)	Removal and Installation	13	O
SERVICE DATA AND SPECIFICATIONS (SDS)	Inspection	14	
Wheel Bearing	REAR DRIVE SHAFT	15	P
AWD	Exploded View	15	
SYMPTOM DIAGNOSIS	Removal and Installation	15	
NOISE, VIBRATION AND HARSHNESS (NVH) TROUBLESHOOTING	Disassembly and Assembly	16	
NVH Troubleshooting Chart	Inspection	21	
	SERVICE DATA AND SPECIFICATIONS (SDS)	23	
	SERVICE DATA AND SPECIFICATIONS (SDS)	23	
	Wheel Bearing	23	
	Drive Shaft	23	

NOISE, VIBRATION AND HARSHNESS (NVH) TROUBLESHOOTING

< SYMPTOM DIAGNOSIS >

[2WD]

SYMPTOM DIAGNOSIS

NOISE, VIBRATION AND HARSHNESS (NVH) TROUBLESHOOTING

NVH Troubleshooting Chart

INFOID:000000005254515

Use chart below to find the cause of the symptom. If necessary, repair or replace these parts.

Reference page			RAX-5	—	RAX-4	NVH in RAX and RSU sections	NVH in WT section	NVH in WT section	NVH in BR section
Possible cause and SUSPECTED PARTS			Improper installation, looseness	Parts interference	Wheel bearing damage	REAR AXLE AND REAR SUSPENSION	TIRE	ROAD WHEEL	BRAKE
Symptom	REAR AXLE	Noise	x	x	x	x	x	x	x
		Shake	x	x	x	x	x	x	x
		Vibration	x	x	x	x	x		
		Shimmy	x	x		x	x	x	x
		Judder	x			x	x	x	x
		Poor quality ride or handling	x	x		x	x	x	

x: Applicable

PREPARATION

< PREPARATION >

[2WD]

PREPARATION

PREPARATION

Commercial Service Tool

INFOID:000000005254516

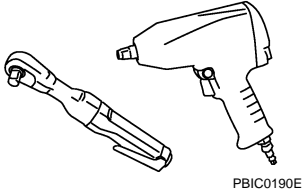
Tool name	Description
Power tool  PBIC0190E	Loosening bolts and nuts

A

B

C

RAX

E

F

G

H

I

J

K

L

M

N

O

P

PERIODIC MAINTENANCE

REAR WHEEL HUB AND HOUSING

Inspection

INFOID:000000005254517

MOUNTING INSPECTION

Make sure the mounting conditions (looseness, back lash) of each component and component conditions (wear, damage) are normal.

WHEEL BEARING INSPECTION

- Move wheel hub and bearing assembly in the axial direction by hand. Make sure there is no looseness of wheel bearing.

Standard

Axial end play : Refer to [RAX-7, "Wheel Bearing"](#).

- Rotate wheel hub, and make sure there is no unusual noise or other irregular conditions. If there is any of irregular conditions, replace wheel hub and bearing assembly.

REAR WHEEL HUB

< REMOVAL AND INSTALLATION >

[2WD]

REMOVAL AND INSTALLATION

REAR WHEEL HUB

Exploded View

INFOID:000000005254518

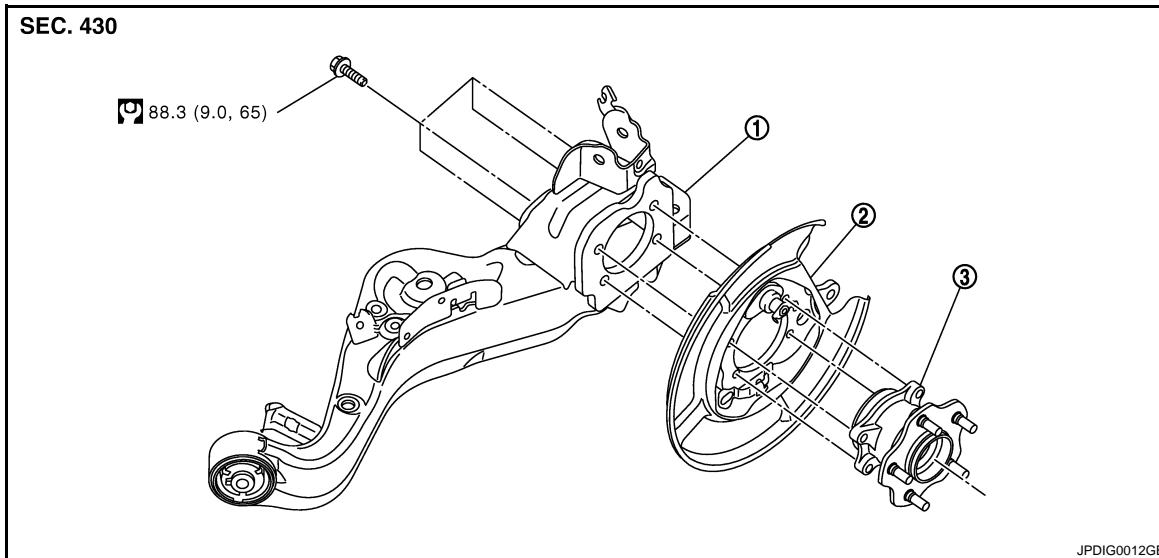

1. Suspension arm
2. Back plate
3. Wheel hub and bearing assembly

Refer to [GI-4, "Components"](#) for symbols in the figure.

Removal and Installation

INFOID:000000005254519

REMOVAL

Wheel Hub and Bearing Assembly

1. Remove tires with power tool.
2. Remove wheel sensor from hub and bearing assembly. Refer to [BRC-176, "REAR WHEEL SENSOR : Exploded View"](#) (without VDC), [BRC-176, "REAR WHEEL SENSOR : Exploded View"](#) (with VDC).
CAUTION:
Never pull on wheel sensor harness.
3. Remove torque member mounting bolts with power tool. Hang torque member not to interfere with work. Refer to [BR-44, "BRAKE CALIPER ASSEMBLY : Exploded View"](#).
CAUTION:
Never depress brake pedal while brake caliper is removed.
4. Remove disc rotor. Refer to [BR-44, "BRAKE CALIPER ASSEMBLY : Removal and Installation"](#).
CAUTION:
 - Put matching marks on the wheel hub and bearing assembly and the disc rotor before removing the disc rotor.
 - Never drop disc rotor.
5. Remove wheel hub and bearing assembly.

INSTALLATION

Note the following, and install in the reverse order of removal.

REAR WHEEL HUB

< REMOVAL AND INSTALLATION >

[2WD]

- Align the matching marks (A) made during removal when reusing the disc rotor.

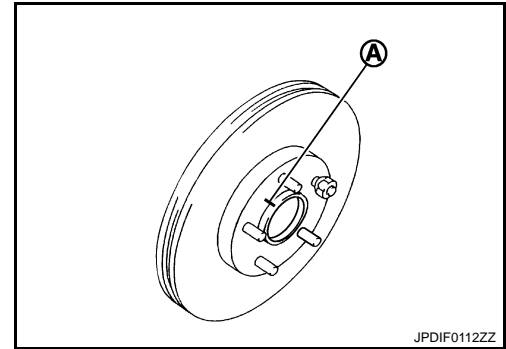

Inspection

INFOID:000000005254520

INSPECTION AFTER REMOVAL

Check wheel hub and bearing assembly for wear, cracks, and damage. Replace if there are.

INSPECTION AFTER INSTALLATION

1. Adjust parking brake operation (stroke). Refer to [PB-3, "Inspection and Adjustment"](#).
2. Check wheel alignment. Refer to [RSU-6, "Inspection"](#).
3. Adjust neutral position of steering angle sensor. Refer to [BRC-76, "ADJUSTMENT OF STEERING ANGLE SENSOR NEUTRAL POSITION : Special Repair Requirement"](#) (with VDC).

SERVICE DATA AND SPECIFICATIONS (SDS)

< SERVICE DATA AND SPECIFICATIONS (SDS)

[2WD]

SERVICE DATA AND SPECIFICATIONS (SDS)

SERVICE DATA AND SPECIFICATIONS (SDS)

Wheel Bearing

INFOID:000000005254521

Item	Standard
Axial end play	0.05 mm (0.002 in) or less

A

B

C

RAX

E

F

G

H

I

J

K

L

M

N

O

P

NOISE, VIBRATION AND HARSHNESS (NVH) TROUBLESHOOTING

< SYMPTOM DIAGNOSIS >

[AWD]

SYMPTOM DIAGNOSIS

NOISE, VIBRATION AND HARSHNESS (NVH) TROUBLESHOOTING

NVH Troubleshooting Chart

INFOID:000000005254522

Use chart below to find the cause of the symptom. If necessary, repair or replace these parts.

Reference page		Possible cause and SUSPECTED PARTS													
		Excessive joint angle	Joint sliding resistance	Imbalance	Improper installation, looseness	Parts interference	PROPELLER SHAFT	DIFFERENTIAL	REAR AXLE AND REAR SUSPENSION	REAR AXLE	TIRE	ROAD WHEEL	DRIVE SHAFT	BRAKE	
Symptom	DRIVE SHAFT	Noise	x	x				x	x	x	x	x		x	
		Shake	x		x			x		x	x	x		x	
	REAR AXLE	Noise				x	x	x	x		x	x	x	x	
		Shake				x	x	x		x		x	x	x	
		Vibration				x	x	x		x		x		x	
		Shimmy				x	x			x		x		x	
		Judder				x				x		x		x	
		Poor quality ride or handling				x	x			x		x			

x: Applicable

PRECAUTIONS

[AWD]

< PRECAUTION >

PRECAUTION

PRECAUTIONS

Precautions for Drive Shaft

INFOID:000000005254523

- Observe the following precautions when disassembling and assembling drive shaft.
- Never disassemble joint sub-assembly because it is non-overhaul parts.
- Perform work in a location which is as dust-free as possible.
- Clean the parts, before disassembling and assembling.
- Prevent the entry of foreign objects during disassembly of the service location.
- Reassemble disassembled parts carefully in the correct order. If work is interrupted, a clean cover must be placed over parts.
- Use paper waste. Fabric shop cloths must not be used because of the danger of lint adhering to parts.
- Clean disassembled parts (except for rubber parts) with kerosene which shall be removed by blowing with air or wiping with paper waste.

A

B

C

RAX

E

F

G

H

I

J

K

L

M

N

O

P

PREPARATION

< PREPARATION >

[AWD]

PREPARATION

PREPARATION

Special Service Tool

INFOID:000000005254524

The actual shapes of Kent-More tools may differ from those of special service tools illustrated here.

Tool number (Kent-More No.) Tool name	Description
KV38100500 (—) Drift a: 80 mm (3.15 in) dia. b: 60 mm (2.36 in) dia.	Installing sensor rotor
KV40101840 (—) Collar a: 67 mm (2.64 in) dia. b: 85 mm (3.35 in) dia.	Installing sensor rotor

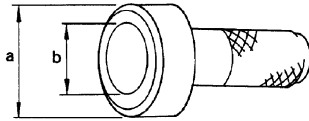

ZZA0701D

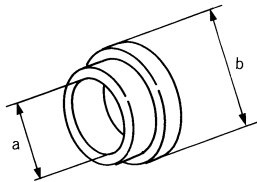

ZZA1113D

Commercial Service Tool

INFOID:000000005254525

Tool name	Description
Power tool	Loosening bolts and nuts

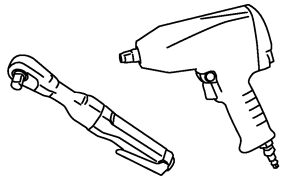

PBIC0190E

REAR WHEEL HUB AND HOUSING

< PERIODIC MAINTENANCE >

[AWD]

PERIODIC MAINTENANCE

REAR WHEEL HUB AND HOUSING

Inspection

INFOID:000000005254526

MOUNTING INSPECTION

Make sure the mounting conditions (looseness, back lash) of each component and component conditions (wear, damage) are normal.

WHEEL BEARING INSPECTION

- Move wheel hub and bearing assembly in the axial direction by hand. Make sure there is no looseness of wheel bearing.

Standard

Axial end play : Refer to [RAX-23, "Wheel Bearing"](#).

- Rotate wheel hub, and make sure there is no unusual noise or other irregular conditions. If there is any of irregular conditions, replace wheel hub and bearing assembly.

A
B
C
RAX
E
F
G
H
I
J
K
L
M
N
O
P

REAR DRIVE SHAFT

< PERIODIC MAINTENANCE >

[AWD]

REAR DRIVE SHAFT

Inspection

INFOID:000000005254527

- Check drive shaft mounting point and joint for looseness and other damage.
- Check boot for cracks and other damage.

CAUTION:

Replace entire drive shaft assembly when noise or vibration occurs from drive shaft.

REAR WHEEL HUB AND HOUSING

< REMOVAL AND INSTALLATION >

[AWD]

REMOVAL AND INSTALLATION

REAR WHEEL HUB AND HOUSING

Exploded View

INFOID:000000005254528

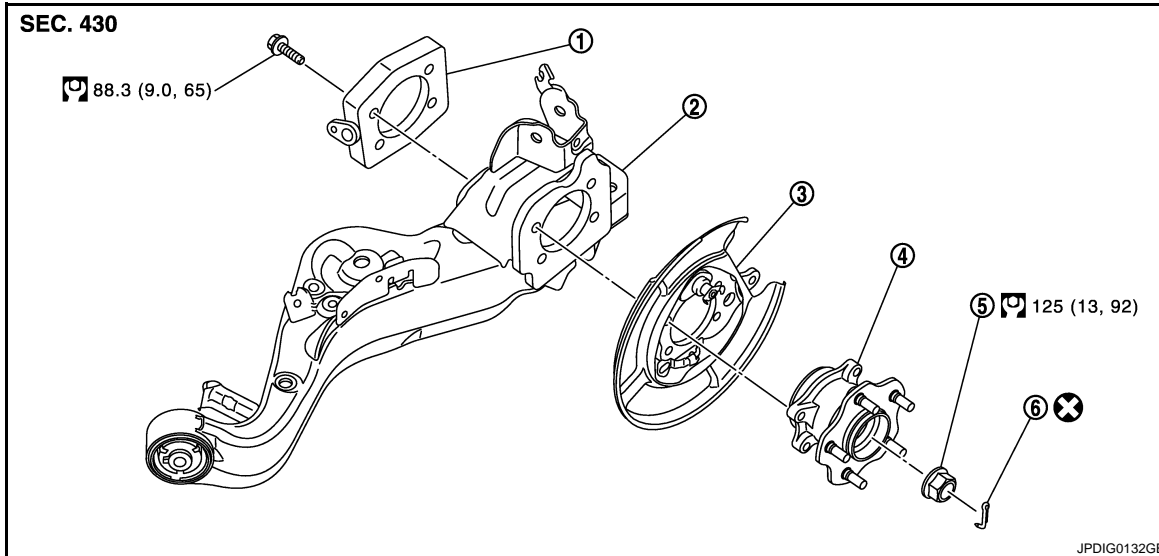

- | | | |
|-----------------------------------|-----------------------|---------------|
| 1. Axle housing | 2. Suspension arm | 3. Back plate |
| 4. Wheel hub and bearing assembly | 5. Wheel hub lock nut | 6. Cotter pin |

Refer to [GI-4, "Components"](#) for symbols in the figure.

Removal and Installation

INFOID:000000005254529

REMOVAL

Wheel Hub and Bearing Assembly

1. Remove tires with power tool.
2. Remove wheel sensor from axle housing. Refer to [BRC-176, "REAR WHEEL SENSOR : Exploded View"](#) (without VDC), [BRC-176, "REAR WHEEL SENSOR : Exploded View"](#) (with VDC).
CAUTION:
Never pull on wheel sensor harness.
3. Remove torque member mounting bolts. Hang torque member not to interfere with work. Refer to [BR-44, "BRAKE CALIPER ASSEMBLY : Exploded View"](#).
CAUTION:
Never depress brake pedal while brake caliper is removed.
4. Remove disc rotor. Refer to [BR-44, "BRAKE CALIPER ASSEMBLY : Removal and Installation"](#).
CAUTION:
 - Put matching marks on the wheel hub and bearing assembly and the disc rotor before removing the disc rotor.
 - Never drop disc rotor.
5. Remove cotter pin, and then loosen wheel hub lock nut with power tool.

REAR WHEEL HUB AND HOUSING

[AWD]

< REMOVAL AND INSTALLATION >

6. Patch wheel hub lock nut with a piece of wood. Hammer the wood to disengage wheel hub and bearing assembly from drive shaft. Remove the wheel hub lock nut.

CAUTION:

- Never place drive shaft joint at an extreme angle. Also be careful not to overextend slide joint.
- Never allow drive shaft to hang down without support for housing (or joint sub-assembly), shaft and the other parts.

NOTE:

Use suitable puller, if wheel hub and bearing assembly and drive shaft cannot be separated even after performing the above procedure.

7. Remove wheel hub and bearing assembly.

INSTALLATION

Note the following, and install in the reverse order of removal.

- Align the matching marks (A) made during removal when reusing the disc rotor.

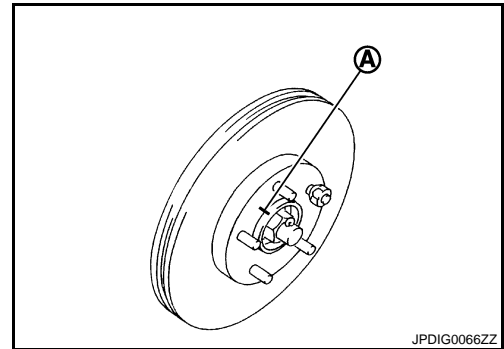
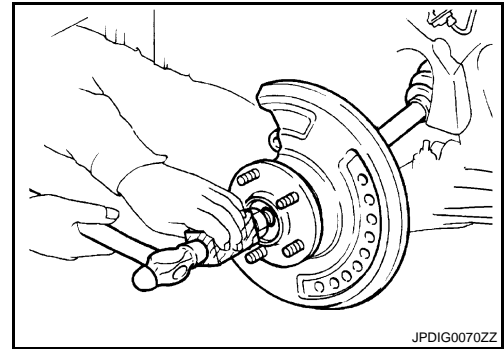

Inspection

INFOID:000000005254530

INSPECTION AFTER REMOVAL

Check wheel hub and bearing assembly for wear, cracks, and damage. Replace if there are abnormal conditions.

INSPECTION AFTER INSTALLATION

1. Adjust parking brake operation (stroke). Refer to [PB-3, "Inspection and Adjustment"](#).
2. Check wheel alignment. Refer to [RSU-6, "Inspection"](#).
3. Adjust neutral position of steering angle sensor. Refer to [BRC-76, "ADJUSTMENT OF STEERING ANGLE SENSOR NEUTRAL POSITION : Special Repair Requirement"](#) (with VDC).

REAR DRIVE SHAFT

< REMOVAL AND INSTALLATION >

[AWD]

REAR DRIVE SHAFT

Exploded View

INFOID:000000005254531

REMOVAL

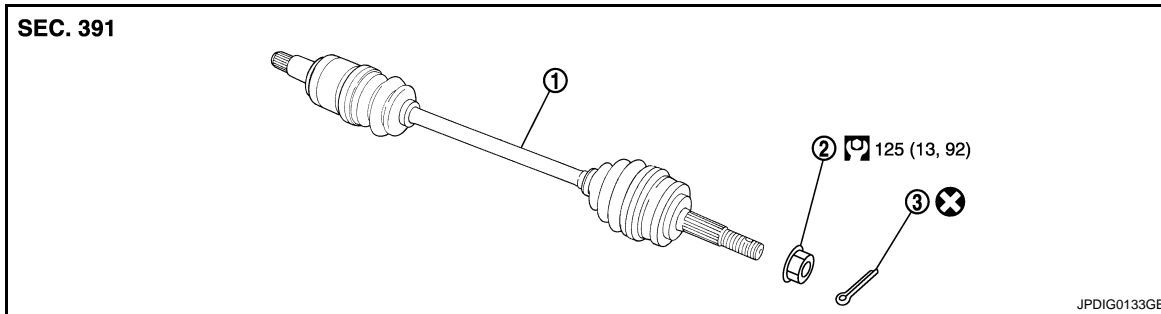

- | | | |
|----------------|-----------------------|---------------|
| 1. Drive shaft | 2. Wheel nub lock nut | 3. Cotter pin |
|----------------|-----------------------|---------------|

Refer to [GI-4, "Components"](#) for symbols in the figure.

DISASSEMBLY

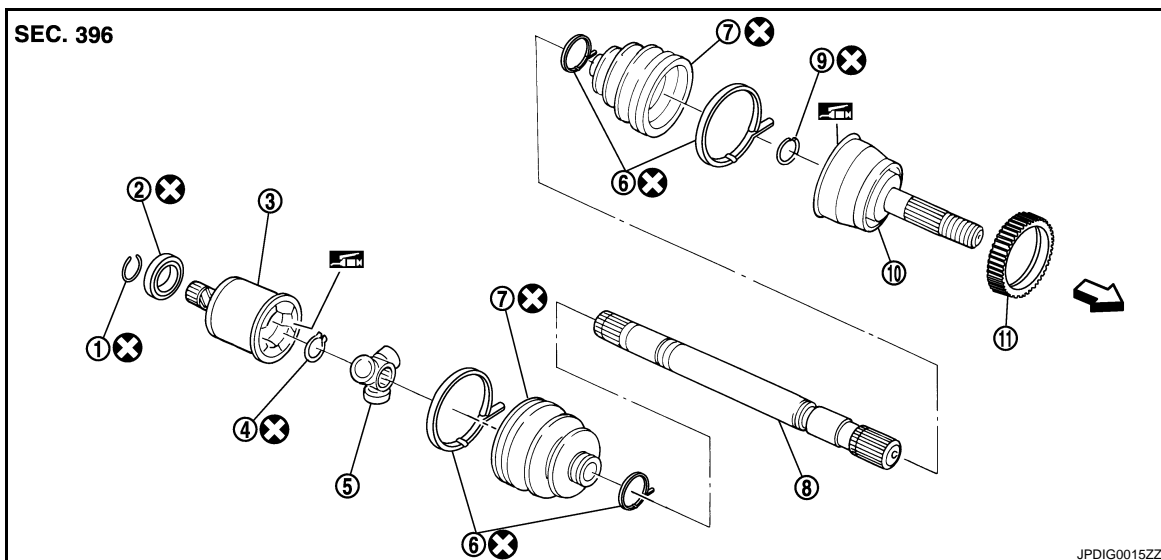

- | | | |
|------------------------|--------------------|------------------|
| 1. Circular clip | 2. Dust shield | 3. Housing |
| 4. Snap ring | 5. Spider assembly | 6. Boot band |
| 7. Boot | 8. Shaft | 9. Circular clip |
| 10. Joint sub-assembly | 11. Sensor rotor | |

⇐: Wheel side

: Fill NISSAN genuine grease or an equivalent.

Refer to [GI-4, "Components"](#) for symbols not described on the above.

Removal and Installation

INFOID:000000005254532

REMOVAL

1. Remove tires with power tool.
2. Remove torque member mounting bolts with power tool. Hang torque member not to interfere with work. Refer to [BR-44, "BRAKE CALIPER ASSEMBLY : Exploded View"](#).

CAUTION:

Never depress brake pedal while brake caliper is removed.

A
B
C
RAX
E
F
G
H
I
J
K
L
M
N
O
P

REAR DRIVE SHAFT

[AWD]

< REMOVAL AND INSTALLATION >

3. Remove disc rotor. Refer to [BR-44, "BRAKE CALIPER ASSEMBLY : Removal and Installation"](#).
4. Remove cotter pin, then loosen wheel hub lock nut with power tool.
5. Patch wheel hub lock nut with a piece of wood. Hammer the wood to disengage wheel hub and bearing assembly from drive shaft.

CAUTION:

- Never place drive shaft joint at an extreme angle. Also be careful not to overextend slide joint.
- Never allow drive shaft to hang down without support for housing (or joint sub-assembly), shaft and the other parts.

NOTE:

Use a suitable puller if the wheel hub and bearing assembly and drive shaft cannot be separated even after performing the above procedure.

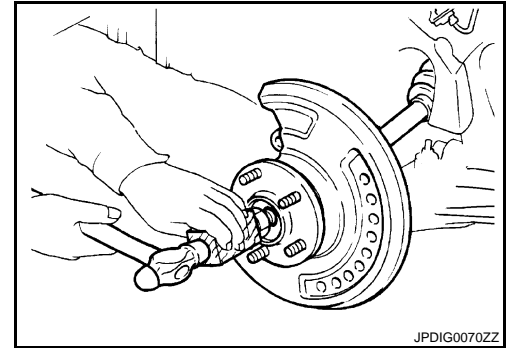

6. Remove the wheel hub lock nut.
7. Remove wheel sensor from axle housing. Refer to [BRC-176, "REAR WHEEL SENSOR : Exploded View"](#) (without VDC), [BRC-176, "REAR WHEEL SENSOR : Exploded View"](#) (with VDC).
8. Remove stabilizer link. Refer to [RSU-18, "Exploded View"](#).
9. Set suitable jack under suspension arm.
10. Remove shock absorber from suspension arm. Refer to [RSU-10, "Exploded View"](#).
11. Remove upper link from suspension arm with power tool. Refer to [RSU-16, "Exploded View"](#).
12. Remove lower link from suspension arm with power tool. Refer to [RSU-14, "Exploded View"](#).
13. Remove drive shaft from final drive assembly.

INSTALLATION

Note the following, and install in the reverse order of removal.

- Align the matching marks (A) made during removal when reusing the disc rotor.
- Perform final tightening of bolts and nuts at suspension arm (rubber bushing), under unladen conditions with tires on level ground.

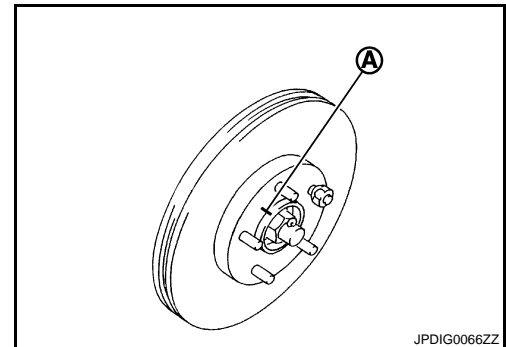

Disassembly and Assembly

INFOID:000000005254533

DISASSEMBLY

Final Drive Side

1. Fix shaft with a vise.
CAUTION:
Protect shaft using aluminum or copper plates when fixing with a vise.
2. Remove boot bands, and then remove boot from housing.
3. Put matching marks on housing and shaft, and then pull out housing from shaft.
CAUTION:
Use paint or an equivalent for matching marks. Never scratch the surface.

REAR DRIVE SHAFT

[AWD]

< REMOVAL AND INSTALLATION >

- Put matching marks (A) on the spider assembly and shaft.

CAUTION:

Use paint or an equivalent for matching marks. Never scratch the surface.

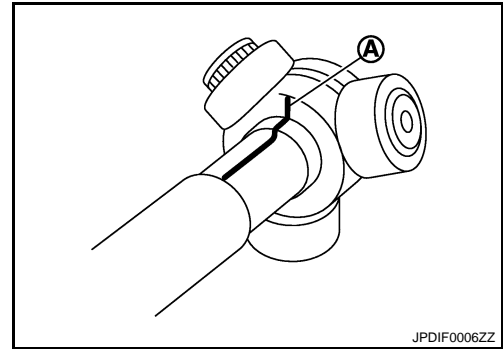

- Remove snap ring (1), and then remove spider assembly from shaft.
- Remove boot from shaft.
- Remove circular clip housing.
- Remove dust shield to housing.
- Remove old grease on housing with paper waste.

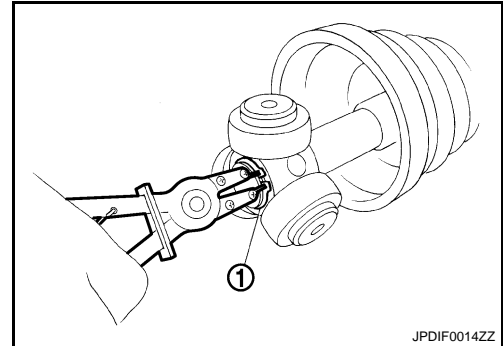

Wheel Side

- If sensor rotor needs to be removed, use a bearing replacer (A) and puller (B).

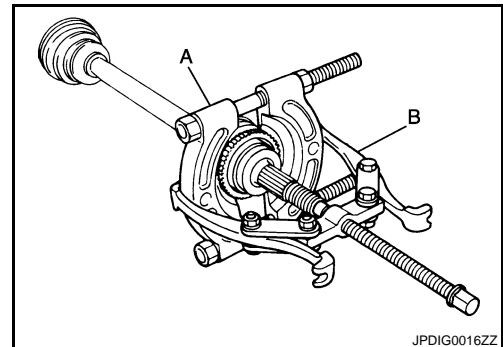

- Fix shaft with a vise.
CAUTION:
Protect shaft using aluminum or copper plates when fixing with a vise.

- Remove boot bands and then remove boot from joint sub-assembly.
- Screw the drive shaft puller (A) 30 mm (1.18 in) or more into the thread of joint sub-assembly, and pull joint sub-assembly with a sliding hammer (B) from shaft.

CAUTION:

- If joint sub-assembly cannot be removed after five or more unsuccessful attempts, replace shaft and joint sub-assembly as a set.
- Align sliding hammer and drive shaft and remove them by pulling forcibly.

- Remove circular clip from shaft.

CAUTION:

Never reuse circular clip.

- Remove boot from shaft.
- Clean old grease on joint sub-assembly with paper waste while rotating ball cage.

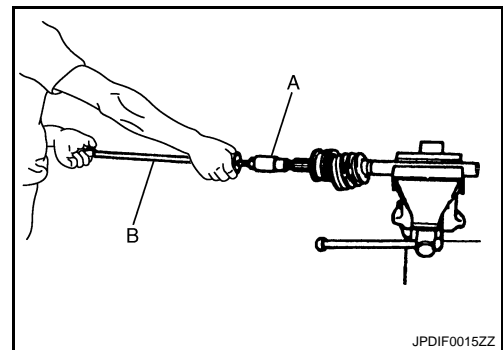

ASSEMBLY

Final drive Side

A
B
C
RAX
E
F
G
H
I
J
K
L
M
N
O
P

REAR DRIVE SHAFT

[AWD]

< REMOVAL AND INSTALLATION >

1. Wrap serration on shaft with tape (A) to protect boot from damage. Install new boot and boot band to shaft.

CAUTION:

Never reuse boot and boot band.

2. Remove the tape wrapped around the serration on shaft.

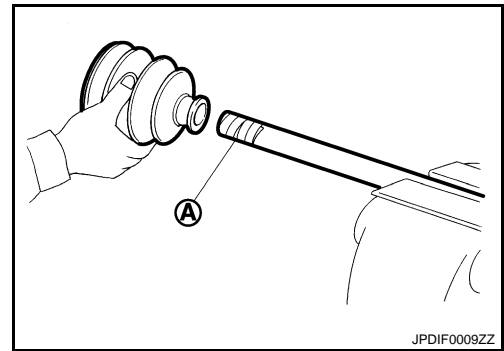

JPDIF0009ZZ

3. To install the spider assembly (1), align it with the matching marks (A) on the shaft (2) put during the removal, and direct the serration mounting surface (B) to the shaft.

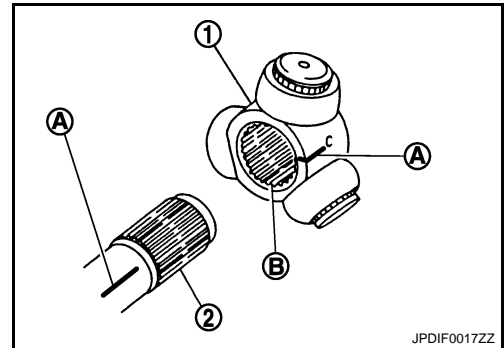

JPDIF0017ZZ

4. Secure spider assembly onto shaft with snap ring (1).

CAUTION:

Never reuse snap ring.

5. Apply the appropriate amount of grease onto housing and sliding surface.
6. Assemble the housing onto spider assembly, and apply the balance of the specified amount grease.

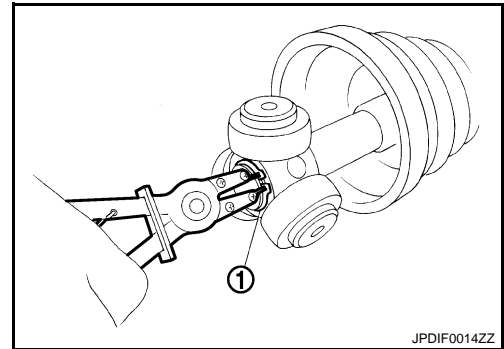

JPDIF0014ZZ

Standard

Grease amount : Refer to [RAX-23, "Drive Shaft"](#).

7. Align matching marks put during the removal of housing.
8. Install boot securely into grooves (indicated by "*" marks) shown in the figure.

CAUTION:

If grease adheres to the boot mounting surfaces (indicated by "*" marks) on shaft or housing, boot may be removed. Remove all grease from the boot mounting surfaces (*).

9. To prevent the deformation of the boot, adjust the boot installation length (L) to the value shown below by inserting the suitable tool into the inside of boot from the large diameter side of boot and discharging inside air.

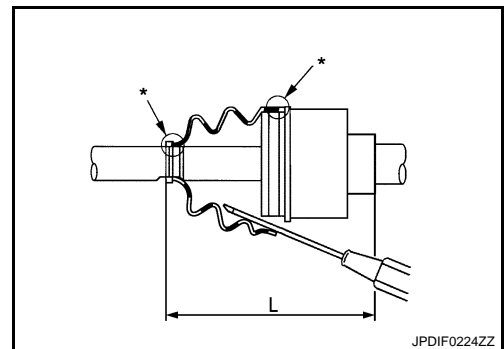

JPDIF0224ZZ

Standard

Boots installed length (L) : Refer to [RAX-23, "Drive Shaft"](#).

CAUTION:

- If the boot installation length is outside the standard, it may cause breakage of boot.
- Be careful not to touch the inside of the boot with the tip of tool.

10. Install new boot bands securely.

CAUTION:

Never reuse boot band.

REAR DRIVE SHAFT

[AWD]

< REMOVAL AND INSTALLATION >

- a. For one-touch clamp band
 - Secure the large and small ends of boot with new boot bands as shown in the figure.

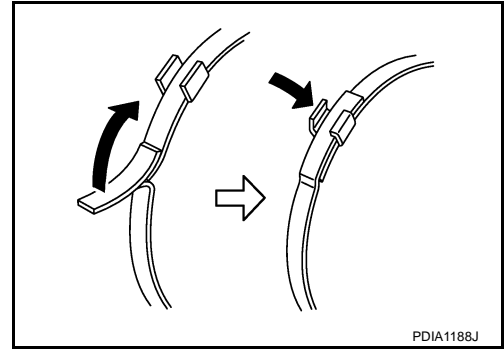

- b. For low profile type band
 - i. Put boot band in the groove on drive shaft boot. Then fit pawls (←) into holes to temporary installation.

NOTE:

For the large diameter side, fit projection (A) and guide slit (B) at first.

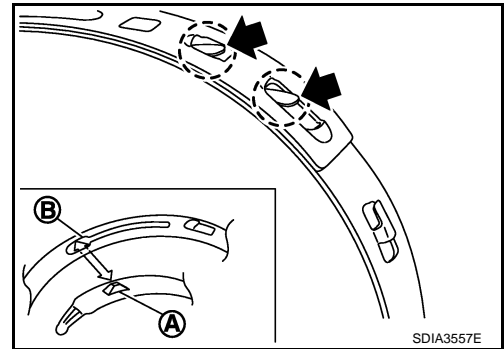

- ii. Pinch projection on the band with suitable pliers to tighten band.
- iii. Insert tip of band below end of the pawl.

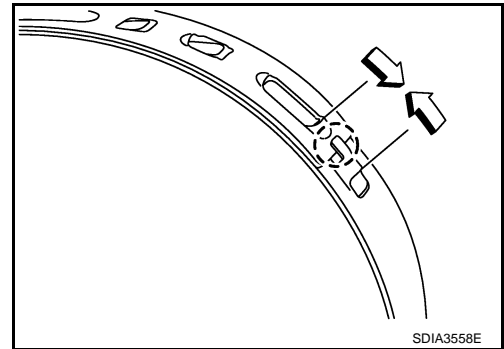

- 11. Secure housing and shaft, and then make sure that they are in the correct position when rotating boot. Install them with new boot band when the mounting positions become incorrect.
- 12. Install dust shield to housing.
 - CAUTION:**
 - Never reuse dust shield.**
- 13. Install circular clip to housing.
 - CAUTION:**
 - Never reuse circular clip.**

Wheel Side

- 1. If sensor rotor (1) is removed, use a drift (A) [SST: KV38100500 (—)] and collar (B) [SST: KV40101840 (—)] to press in a new one.

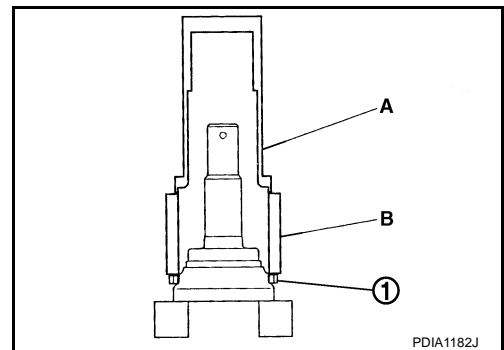

A
B
C
RAX
E
F
G
H
I
J
K
L
M
N
O
P

REAR DRIVE SHAFT

< REMOVAL AND INSTALLATION >

[AWD]

2. Fill serration slot joint sub-assembly (1) with NISSAN genuine grease or equivalent until the serration slot and ball groove become full to the brim.

CAUTION:

After applying grease, use a paper waste to wipe off old grease that has oozed out.

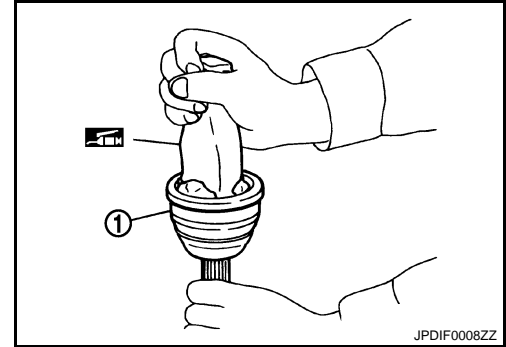

3. Wrap separation on shaft with tape (A) to protect the boot from damage. Install boot and boot band to shaft.

CAUTION:

Never reuse boot and boot band.

4. Remove the tape wrapped around the serration on shaft.

5. Position circular clip on groove at the shaft edge.

CAUTION:

Never reuse circular clip.

NOTE:

Drive joint inserter is recommended when installing circular clip.

6. Align both center axles of the shaft edge and joint sub-assembly. Then assemble shaft with circular clip joint sub-assembly.

7. Install joint sub-assembly to shaft using plastic hammer.

CAUTION:

Confirm that joint sub-assembly is correctly engaged while rotating drive shaft.

8. Apply the balance of the specified amount of grease into the boot inside from large diameter side of boot.

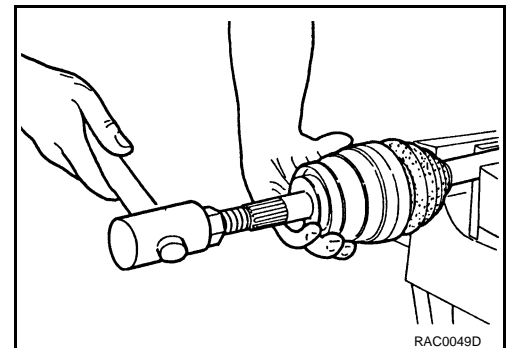
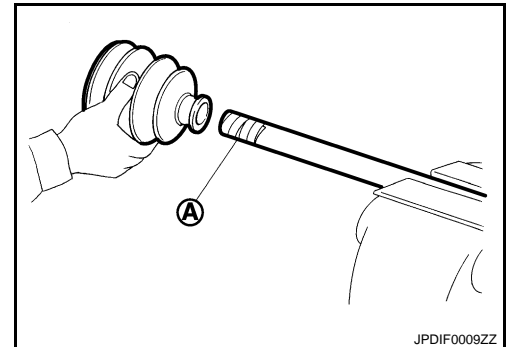

Standard

Grease amount : Refer to [RAX-23, "Drive Shaft"](#).

9. Install the boot securely into grooves (indicated by "*" marks) shown in the figure.

CAUTION:

If grease adheres to the boot mounting surface (indicated by "*" mark) on the shaft or joint sub-assembly, boot may be removed. Remove all grease from the boot mounting surfaces.

10. To prevent the deformation of the boot, adjust the boot installation length (L) to the specified value shown below by inserting the suitable tool into inside of the boot from the large diameter side of boot and discharging the inside air.

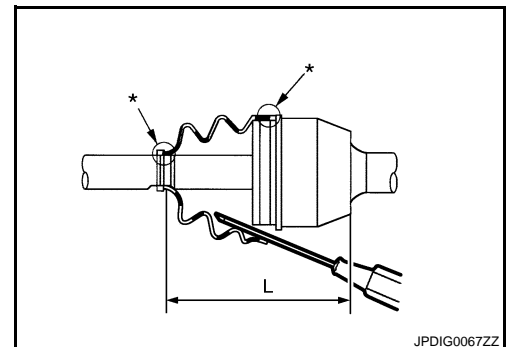

Standard

Boots installed length (L) : Refer to [RAX-23, "Drive Shaft"](#).

CAUTION:

- If the boot installation length is outside the standard, it may cause breakage of boot.
- Be careful not to touch the inside of the boot with the tip of tool.

11. Install new boot bands securely.

CAUTION:

REAR DRIVE SHAFT

< REMOVAL AND INSTALLATION >

[AWD]

Never reuse boot band.

- a. For one-touch clamp band
 - Secure the large and small ends of boot with new boot bands as shown in the figure.

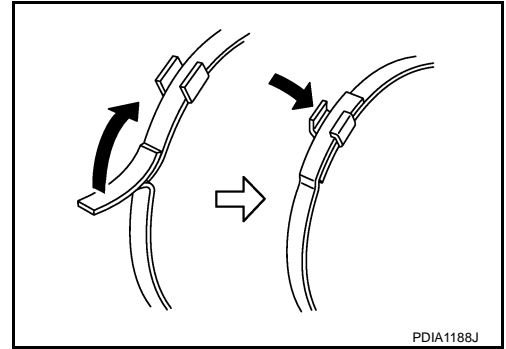

- b. For low profile type band
 - i. Put boot band in the groove on drive shaft boot. Then fit pawls (←) into holes to temporary installation.

NOTE:

For the large diameter side, fit projection (A) and guide slit (B) at first.

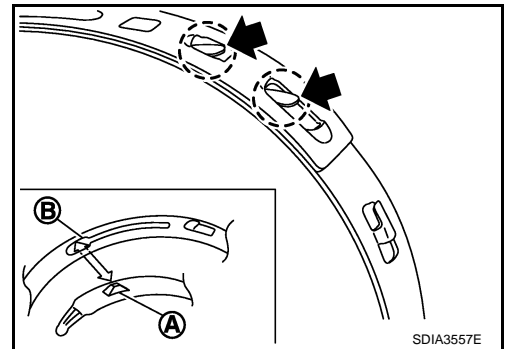

- ii. Pinch projection on the band with suitable pliers to tighten band.
 - iii. Insert tip of band below end of the pawl.

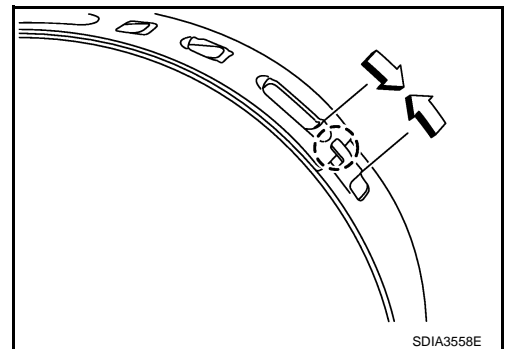

- 12. Secure joint sub-assembly and shaft, and then make sure that they are in the correct position when rotating boot. Install them with new boot band when the mounting positions become incorrect.

Inspection

INFOID:000000005254534

INSPECTION AFTER REMOVAL

- Move joint up/down, left/right, and in the axial direction. Check for motion that is not smooth and for significant looseness.
- Check boot for cracks or other damage, and also for grease leakage.
- If a malfunction is found, disassemble drive shaft, and then replace with new one.

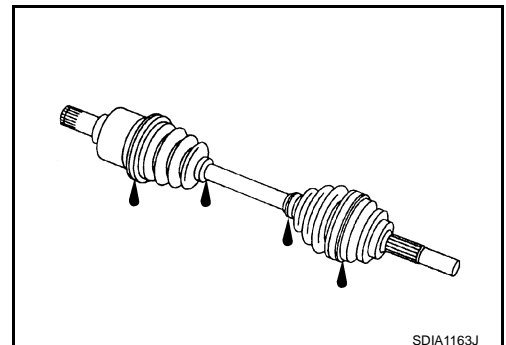

A
B
C
RAX
E
F
G
H
I
J
K
L
M
N
O
P

REAR DRIVE SHAFT

< REMOVAL AND INSTALLATION >

[AWD]

INSPECTION AFTER DISASSEMBLY

Shaft

Check shaft for runout, cracks, or other damage. Replace if there are any abnormal condition.

Joint Sub-Assembly (Wheel Side)

Check the following:

- Joint sub-assembly for rough rotation and excessive axial looseness.
 - The inside of the joint sub-assembly for entry of foreign material.
 - Joint sub-assembly for compression scars, cracks, and fractures inside of joint sub-assembly.
- Replace joint sub-assembly if there are any non-standard conditions of components.

Housing and Spider assembly (Final Drive Side)

Replace housing and spider assembly if there is scratching or wear of housing roller contact surface or spider roller contact surface.

NOTE:

Housing and spider assembly are used in a set.

SERVICE DATA AND SPECIFICATIONS (SDS)

< SERVICE DATA AND SPECIFICATIONS (SDS)

[AWD]

SERVICE DATA AND SPECIFICATIONS (SDS)

SERVICE DATA AND SPECIFICATIONS (SDS)

Wheel Bearing

INFOID:0000000005254535

Item	Standard
Axial end play	0.05 mm (0.002 in) or less

Drive Shaft

INFOID:0000000005254536

Item	Standard	
	Wheel side	Final drive side
Joint		
Grease quantity	35 – 45 g (1.23 – 1.59 oz)	40 – 50 g (1.41 – 1.76 oz)
Boots installed length (L)	90.2 – 92.2 mm (3.551 – 3.630 in)	151.55 – 153.55 mm (5.97 – 6.05 in)

A
B
C
RAX
E
F
G
H
I
J
K
L
M
N
O
P