

SECTION **MA**
 MAINTENANCE

A
 B
 C
 D
 E
 F
 G
 H
 I
 J
 K
 L
 M
 N
 O

CONTENTS

PREPARATION	3	FOR MEXICO	16
PREPARATION	3	FOR MEXICO : Fluids and Lubricants	16
FOR NORTH AMERICA	3	FOR MEXICO : SAE Viscosity Number	17
FOR NORTH AMERICA : Special Service Tool	3	FOR MEXICO : Engine Coolant Mixture Ratio	17
FOR NORTH AMERICA : Commercial Service Tool	3	ENGINE MAINTENANCE	18
FOR MEXICO	3	DRIVE BELTS	18
FOR MEXICO : Special Service Tool	4	DRIVE BELTS : Exploded View	18
FOR MEXICO : Commercial Service Tool	4	DRIVE BELTS : Checking	18
PERIODIC MAINTENANCE	5	DRIVE BELTS : Tension Adjustment	18
GENERAL MAINTENANCE	5	ENGINE COOLANT	18
FOR NORTH AMERICA	5	ENGINE COOLANT : Inspection	18
FOR NORTH AMERICA : Explanation of General Maintenance	5	ENGINE COOLANT : Draining	19
FOR MEXICO	6	ENGINE COOLANT : Refilling	20
FOR MEXICO : General Maintenance	6	ENGINE COOLANT : Flushing	21
PERIODIC MAINTENANCE	9	RADIATOR CAP	22
FOR NORTH AMERICA	9	RADIATOR CAP : Inspection	22
FOR NORTH AMERICA : Introduction of Periodic Maintenance	9	RADIATOR	23
FOR NORTH AMERICA : Schedule 1	9	RADIATOR : Inspection	23
FOR NORTH AMERICA : Schedule 2	11	FUEL LINES	23
FOR MEXICO	12	FUEL LINES : Inspection	24
FOR MEXICO : Periodic Maintenance	12	AIR CLEANER FILTER	24
RECOMMENDED FLUIDS AND LUBRICANTS	15	AIR CLEANER FILTER : Removal and Installation	24
FOR NORTH AMERICA	15	ENGINE OIL	24
FOR NORTH AMERICA : Fluids and Lubricants	15	ENGINE OIL : Draining	24
FOR NORTH AMERICA : Engine Oil Recommendation	15	ENGINE OIL : Refilling	25
FOR NORTH AMERICA : Anti-Freeze Coolant Mixture Ratio	16	OIL FILTER	25
		OIL FILTER : Removal and Installation	25
		OIL FILTER : Inspection	26
		SPARK PLUG	26
		SPARK PLUG : Removal and Installation	26
		SPARK PLUG : Inspection	26
		EVAP VAPOR LINES	27

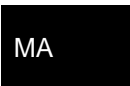

EVAP VAPOR LINES : Inspection	27	STEERING GEAR AND LINKAGE : Inspection	36
CHASSIS MAINTENANCE	28	AXLE AND SUSPENSION PARTS	36
EXHAUST SYSTEM	28	AXLE AND SUSPENSION PARTS : Inspection	37
EXHAUST SYSTEM : Inspection	28	DRIVE SHAFT	37
CVT FLUID	28	DRIVE SHAFT : Inspection	37
CVT FLUID : Inspection	28	BODY MAINTENANCE	38
CVT FLUID : Changing	29	LOCKS, HINGES AND HOOD LATCH	38
TRANSFER OIL	30	LOCKS, HINGES AND HOOD LATCH : Lubricat-	
TRANSFER OIL : Inspection	30	ing	38
TRANSFER OIL : Draining	30	SEAT BELT, BUCKLES, RETRACTORS, AN-	
TRANSFER OIL : Refilling	30	CHORS AND ADJUSTERS	38
REAR PROPELLER SHAFT	31	SEAT BELT, BUCKLES, RETRACTORS, AN-	
REAR PROPELLER SHAFT : Inspection	31	CHORS AND ADJUSTERS : Inspection	38
REAR DIFFERENTIAL GEAR OIL	31	SERVICE DATA AND SPECIFICATIONS	
REAR DIFFERENTIAL GEAR OIL : Inspection	31	(SDS)	39
REAR DIFFERENTIAL GEAR OIL : Draining	31	SERVICE DATA AND SPECIFICATIONS	
REAR DIFFERENTIAL GEAR OIL : Refilling	32	(SDS)	39
WHEELS	32	DRIVE BELTS	39
WHEELS : Adjustment	32	DRIVE BELTS : Drive belt	39
BRAKE FLUID LEVEL AND LEAKS	34	ENGINE COOLANT	39
BRAKE FLUID LEVEL AND LEAKS : Inspection ...	34	ENGINE COOLANT : Periodical Maintenance	
BRAKE LINES AND CABLES	34	Specification	39
BRAKE LINES AND CABLES : Inspection	35	ENGINE OIL	39
BRAKE FLUID	35	ENGINE OIL :	
BRAKE FLUID : Changing	35	Periodical Maintenance Specification	39
DISC BRAKE	35	SPARK PLUG	39
DISC BRAKE : Inspection	35	SPARK PLUG : Spark Plug	39
DISC BRAKE : Front Disc Brake	36	ROAD WHEEL	39
DISC BRAKE : Rear Disc Brake	36	ROAD WHEEL : Road Wheel	39
STEERING GEAR AND LINKAGE	36		

PREPARATION

< PREPARATION >

PREPARATION

PREPARATION
FOR NORTH AMERICA

FOR NORTH AMERICA : Special Service Tool

INFOID:000000007351391

The actual shapes of Kent-Moore tools may differ from those of special service tools illustrated here.

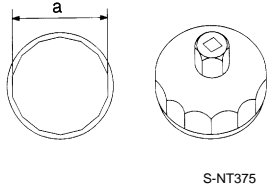
Tool number (Kent-Moore No.) Tool name	Description
KV10115801 (J-38956) Oil filter wrench  <p style="text-align: center;">S-NT375</p>	Removing and installing oil filter a: 64.3 mm (2.531 in)

FOR NORTH AMERICA : Commercial Service Tool

INFOID:000000007351392

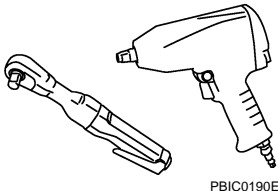
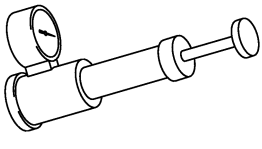
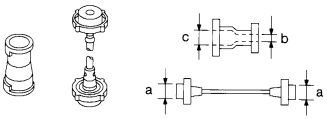
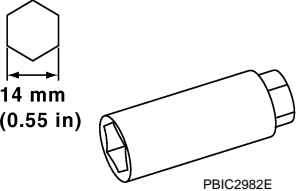
(Kent-Moore No.) Tool name	Description
(—) Power tool  <p style="text-align: center;">PBIC0190E</p>	Loosening nuts and bolts
(—) Radiator cap tester  <p style="text-align: center;">PBIC1982E</p>	Checking radiator and radiator cap
(—) Radiator cap tester adapter  <p style="text-align: center;">S-NT564</p>	Adapting radiator cap tester to radiator cap and radiator filler neck a: 28 (1.10) dia. b: 31.4 (1.236) dia. c: 41.3 (1.626) dia. Unit: mm (in)
(—) Spark plug wrench  <p style="text-align: center;">PBIC2982E</p>	Removing and installing spark plug

FOR MEXICO

A
B
C
D
E
F
G
H
I
J
K
L
M
N
O

MA

PREPARATION

< PREPARATION >

FOR MEXICO : Special Service Tool

INFOID:000000007351393

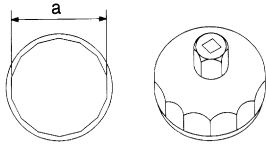
Tool number Tool name	Description
KV10115801 Oil filter wrench  <p style="text-align: center;">S-NT375</p>	Removing and installing oil filter a: 64.3 mm (2.531 in)

FOR MEXICO : Commercial Service Tool

INFOID:000000007351394

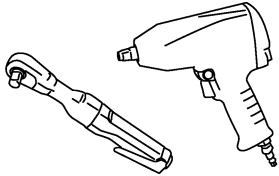
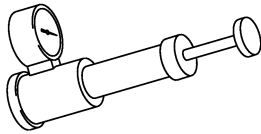
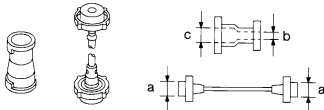
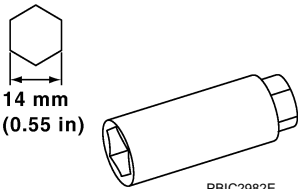
Tool name	Description
Power tool  <p style="text-align: center;">PBIC0190E</p>	Loosening nuts and bolts
Radiator cap tester  <p style="text-align: center;">PBIC1982E</p>	Checking radiator and radiator cap
Radiator cap tester adapter  <p style="text-align: center;">S-NT564</p>	Adapting radiator cap tester to radiator cap and radiator filler neck a: 28 (1.10) dia. b: 31.4 (1.236) dia. c: 41.3 (1.626) dia. Unit: mm (in)
Spark plug wrench  <p style="text-align: center;">PBIC2982E</p>	Removing and installing spark plug

GENERAL MAINTENANCE

< PERIODIC MAINTENANCE >

PERIODIC MAINTENANCE

GENERAL MAINTENANCE FOR NORTH AMERICA

FOR NORTH AMERICA : Explanation of General Maintenance

INFOID:000000007351395

General maintenance includes those items which should be checked during the normal day-to-day operation of the vehicle. They are essential if the vehicle is to continue operating properly. The owners can perform checks and inspections themselves or have their **NISSAN** dealers do them.

OUTSIDE THE VEHICLE

The maintenance items listed here should be performed from time to time, unless otherwise specified.

Item		Reference page
Tires	Check the pressure with a gauge often and always prior to long distance trips. Adjust the pressure in all tires, including the spare, to the pressure specified. Check carefully for damage, cuts or excessive wear.	WT-49
Wheel nuts	When checking the tires, make sure no nuts are missing, and check for any loose nuts. Tighten if necessary.	—
Tire rotation	Tires should be rotated every 7,500 miles (12,000 km). If the vehicle is equipped with different sized tires in the front and rear, tires cannot be rotated.	MA-32
Tire Pressure Monitoring System (TPMS) transmitter components	Replace the TPMS transmitter grommet seal, valve core and cap when the tires are replaced due to wear or age.	WT-9
Wheel alignment and balance	If the vehicle should pull to either side while driving on a straight and level road, or if you detect uneven or abnormal tire wear, there may be a need for wheel alignment. If the steering wheel or seat vibrates at normal highway speeds, wheel balancing may be needed. For additional information regarding tires, refer to "Important Tire Safety Information" (US) or "Tire Safety Information" (Canada) in the NISSAN Warranty Information Booklet.	FSU-7 RSU-6 MA-32
Windshield	Clean the windshield on a regular basis. Check the windshield at least every six months for cracks or other damage. Repair as necessary.	—
Windshield wiper blades	Check for cracks or wear if they do not wipe properly.	—
Doors and engine hood	Check that all doors and the engine hood operate smoothly as well as the back door. Also make sure that all latches lock securely. Lubricate if necessary. Make sure that the secondary latch keeps the hood from opening when the primary latch is released. When driving in areas using road salt or other corrosive materials, check lubrication frequently.	MA-38
Lamps	Make sure that the headlamps, stop lamps, tail lamps, turn signal lamps, and other lamps are all operating properly and installed securely. Also check headlamp aim. Clean the headlamps on a regular basis.	—

INSIDE THE VEHICLE

The maintenance items listed here should be checked on a regular basis, such as when performing periodic maintenance, cleaning the vehicle, etc.

Item		Reference page
Warning lamps and chimes	Make sure that all warning lamps and chimes are operating properly.	—
Windshield wiper and washer	Check that the wipers and washer operate properly and that the wipers do not streak.	—
Windshield defroster	Check that the air comes out of the defroster outlets properly and in sufficient quantity when operating the heater or air conditioner.	—
Steering wheel	Check that it has the specified play. Check for changes in the steering condition, such as excessive play, hard steering or strange noises. Free play: Less than 35 mm (1.38 in)	—

GENERAL MAINTENANCE

< PERIODIC MAINTENANCE >

Item		Reference page
Seats	Check seat position controls such as seat adjusters, seatback recliner, etc. to make sure they operate smoothly and that all latches lock securely in every position. Check that the head restraints move up and down smoothly and that the locks (if equipped) hold securely in all latched positions. Check that the latches lock securely for folding-down rear seatbacks.	—
Seat belts	Check that all parts of the seat belt system (e.g. buckles, anchors, adjusters and retractors) operate properly and smoothly and are installed securely. Check the belt webbing for cuts, fraying, wear or damage.	MA-38
Accelerator pedal	Check the pedal for smooth operation and make sure the pedal does not catch or require uneven effort. Keep the floor mats away from the pedal.	—
Brakes	Check that the brake does not pull the vehicle to one side when applied.	—
Brake pedal and booster	Check the pedal for smooth operation and make sure it has the proper distance under it when depressed fully. Check the brake booster function. Be sure to keep the floor mats away from the pedal.	BR-8 BR-14
Parking brake	Check that the lever or the pedal has the proper travel and make sure that the vehicle is held securely on a fairly steep hill when only the parking brake is applied.	PB-3
CVT P (Park) position mechanism	On a fairly steep hill check that the vehicle is held securely with the selector lever in the P (Park) position without applying any brakes.	—

UNDER THE HOOD AND VEHICLE

The maintenance items listed here should be checked periodically (e.g. each time you check the engine oil or refuel).

Item		Reference page
Windshield washer fluid	Check that there is adequate fluid in the tank.	—
Engine coolant level	Check the coolant level when the engine is cold.	MA-18
Radiator and hoses	Check the front of the radiator and clean off any dirt, insects, leaves, etc., that may have accumulated. Make sure the hoses have no cracks, deformation, deterioration or loose connections.	MA-23
Brake fluid level	Make sure that the brake fluid level is between the "MAX" and "MIN" lines on the reservoir.	MA-34
Battery	Check the fluid level in each cell. It should be between the "MAX" and "MIN" lines. Vehicles operated in high temperatures or under severe conditions require frequent checks of the battery fluid level.	PG-3
Engine drive belts	Make sure that no belt is frayed, worn, cracked or oily.	MA-18
Engine oil level	Check the level on the oil level gauge after parking the vehicle on a level spot and turning off the engine.	LU-5
Exhaust system	Make sure there are no loose supports, cracks or holes. If the sound of the exhaust seems unusual or there is a smell of exhaust fumes, immediately locate the trouble and correct it.	MA-28
Underbody	The underbody is frequently exposed to corrosive substances such as those used on icy roads or to control dust. It is very important to remove these substances, otherwise rust will form on the floor pan, frame, fuel lines and around the exhaust system. At the end of winter, the underbody should be thoroughly flushed with plain water, being careful to clean those areas where mud and dirt can easily accumulate.	—
Fluid leaks	Check under the vehicle for fuel, oil, water or other fluid leaks after the vehicle has been parked for a while. Water dripping from the air conditioner after use is normal. If you should notice any leaks or gasoline fumes are evident, check for the cause and correct it immediately.	—

FOR MEXICO

FOR MEXICO : General Maintenance

INFOID:000000007732559

General maintenance includes those items which should be checked during the normal day-to-day operation of the vehicle. They are essential if the vehicle is to continue operating properly. The owners can perform the checks and inspections themselves or they can have their **NISSAN** dealers do them.

GENERAL MAINTENANCE

< PERIODIC MAINTENANCE >

OUTSIDE THE VEHICLE

The maintenance items listed here should be performed from time to time, unless otherwise specified.

Item	Reference page
Lamps Clean the head lamps on a regular basis. Make sure that the headlamps, stop lamps, tail lamps, turn signal lamps, and other lamps are all operating properly and installed securely. Also check the aim of the headlamps.	—
Tires Check the pressure with a gauge often and always prior to long distance trips. Adjust the pressure in all tires, including the spare, to the pressure specified. Check carefully for damage, cuts or excessive wear.	WT-49
Wiper blades Check for cracks or wear if not functioning correctly.	—
Doors and engine hood Check that all doors and the engine hood operate smoothly as well as the back door, trunk lid and glass hatch. Also make sure that all latches lock securely. Lubricate if necessary. Make sure that the secondary latch keeps the hood from opening when the primary latch is released. When driving in areas using road salt or other corrosive materials, check lubrication frequently.	MA-38
Tire rotation Tires should be rotated every 10,000 km (6,000 miles) for 2WD models and every 5,000 km (3,000 miles) for 4WD models.	MA-32
Windshield Clean the windshield on a regular basis. Check the windshield at least every six months for cracks or other damage. Repair as necessary.	—

INSIDE THE VEHICLE

The maintenance items listed here should be checked on a regular basis, such as when performing periodic maintenance, cleaning the vehicle, etc.

Item	Reference page
Accelerator pedal Check the pedal for smooth operation and make sure that the pedal does not catch or require uneven effort. Keep the floor mats away from the pedal.	—
Brake pedal Check the pedal for smooth operation and make sure that it has the proper distance under it when depressed fully. Check the brake booster function. Be sure to keep the floor mats away from the pedal.	BR-8
Parking brake Check that the lever or the pedal has the proper travel and make sure that the vehicle is held securely on a fairly steep hill when only the parking brake is applied.	PB-3
Warning lamps and chimes Make sure that all warning lamps and chimes are operating properly.	—
Windshield defogger Check that the air comes out of the defogger outlets properly and in good quantity when operating the heater or air conditioner.	—
Windshield wiper and washer Check that the wipers and washer operate properly and that the wipers do not streak.	—
Steering wheel Check that it has the specified play. Check for changes in the steering condition, such as excessive play, hard steering or strange noises. Free play: Less than 35 mm (1.38 in)	—
Seat belts Check that all parts of the seat belt system (e.g. buckles, anchors, adjusters and retractors) operate properly and smoothly, and are installed securely. Check the belt webbing for cuts, fraying, wear or damage.	MA-38

UNDER THE HOOD AND VEHICLE

The maintenance items listed here should be checked periodically (e.g. each time you check the engine oil or refuel.)

Item	Reference page
Windshield washer fluid Check that there is adequate fluid in the tank.	—
Engine coolant level Check the coolant level when the engine is cold.	MA-18
Engine drive belts Make sure that drive belts are not frayed, worn, cracked or oily.	MA-18
Engine oil level Check the level after parking the vehicle (on a level ground) and turning off the engine.	LU-5
Brake fluid level Make sure that the brake fluid level is between the "MAX" and "MIN" lines on the reservoir.	MA-34

GENERAL MAINTENANCE

< PERIODIC MAINTENANCE >

	Item	Reference page
Battery	Check the fluid level in each cell. It should be between the "MAX" and "MIN" lines. Vehicles operated in high temperatures or under severe conditions require frequent checks of the battery fluid level.	PG-3
Fluid leaks	Check under the vehicle for fuel, oil, water or other fluid leaks after the vehicle has been parked for a while. Water dripping from the air conditioner after use is normal. If you should notice any leaks or if fuel fumes are evident, check for cause and have it corrected immediately.	—

PERIODIC MAINTENANCE

< PERIODIC MAINTENANCE >

PERIODIC MAINTENANCE FOR NORTH AMERICA

FOR NORTH AMERICA : Introduction of Periodic Maintenance

INFOID:000000007351397

Two different maintenance schedules are provided, and should be used, depending upon the conditions in which the vehicle is mainly operated. **After 60,000 miles (96,000 km) or 48 months, continue the periodic maintenance at the same mileage/time intervals.**

Schedule 1	Follow Periodic Maintenance Schedule 1 if the driving habits frequently include one or more of the following driving conditions: <ul style="list-style-type: none"> • Repeated short trips of less than 5 miles (8 km). • Repeated short trips of less than 10 miles (16 km) with outside temperatures remaining below freezing. • Operating in hot weather in stop-and-go "rush hour" traffic. • Extensive idling and/or low speed driving for long distances, such as police, taxi or door-to-door delivery use. • Driving in dusty conditions. • Driving on rough, muddy, or salt spread roads. • Towing a trailer, using a camper or a car-top carrier. 	Emission Control System Maintenance	MA-9
		Chassis and Body Maintenance	MA-9
Schedule 2	Follow Periodic Maintenance Schedule 2 if none of driving conditions shown in Schedule 1 apply to the driving habits.	Emission Control System Maintenance	MA-11
		Chassis and Body Maintenance	MA-11

FOR NORTH AMERICA : Schedule 1

INFOID:000000007351398

EMISSION CONTROL SYSTEM MAINTENANCE

Abbreviations: R = Replace. I = Inspect. Correct or replace if necessary. []: At the mileage intervals only

MAINTENANCE OPERATION		MAINTENANCE INTERVAL								Reference Section - Page or - Content Title
Perform at number of miles, kilometers or months, whichever comes first.	Miles x 1,000 (km x 1,000) Months	3.75 (6)	7.50 (12)	11.25 (18)	15 (24)	18.75 (30)	22.5 (36)	26.25 (42)	30 (48)	
Drive belts	NOTE (1)									MA-18
Air cleaner filter	NOTE (2)								[R]	MA-24
EVAP vapor lines									I*	MA-27
Fuel lines									I*	MA-24
Fuel filter	NOTE (3)									-
Engine coolant*	NOTE (4)									MA-19
Engine oil		R	R	R	R	R	R	R	R	MA-24
Engine oil filter (Use genuine NISSAN engine oil filter or equivalent.)		R	R	R	R	R	R	R	R	MA-25
Spark plugs (Iridium-tipped type)		Replace every 105,000 miles (168,000 km).								MA-26
Intake & exhaust valve clearance*	NOTE (5)									EM-22

MAINTENANCE OPERATION		MAINTENANCE INTERVAL								Reference Section - Page or - Content Title
Perform at number of miles, kilometers or months, whichever comes first.	Miles x 1,000 (km x 1,000) Months	33.75 (54)	37.5 (60)	41.25 (66)	45 (72)	48.75 (78)	52.5 (84)	56.25 (90)	60 (96)	
Drive belts	NOTE (1)								I*	MA-18
Air cleaner filter	NOTE (2)								[R]	MA-24
EVAP vapor lines									I*	MA-27

PERIODIC MAINTENANCE

< PERIODIC MAINTENANCE >

MAINTENANCE OPERATION		MAINTENANCE INTERVAL								Reference Section - Page or - Content Title
Perform at number of miles, kilometers or months, whichever comes first.	Miles x 1,000 (km x 1,000) Months	33.75 (54) 27	37.5 (60) 30	41.25 (66) 33	45 (72) 36	48.75 (78) 39	52.5 (84) 42	56.25 (90) 45	60 (96) 48	
Fuel lines									I*	MA-24
Fuel filter	NOTE (3)									-
Engine coolant*	NOTE (4)									MA-19
Engine oil		R	R	R	R	R	R	R	R	MA-24
Engine oil filter (Use genuine NISSAN engine oil filter or equivalent.)		R	R	R	R	R	R	R	R	MA-25
Spark plugs (Iridium-tipped type)		Replace every 105,000 miles (168,000 km).								MA-26
Intake & exhaust valve clearance*	NOTE (5)									EM-22

NOTE:

(1) After 60,000 miles (96,000 km) or 48 months, inspect every 15,000 miles (24,000 km) or 12 months. Replace the drive belts if found damaged (or if the auto belt tensioner reading reaches maximum limit).

(2) If operating mainly in dusty conditions, more frequent maintenance may be required.

(3) Maintenance-free item. For service procedures, refer to FL section.

(4) First replacement interval is 105,000 miles (168,000 km) or 84 months. After first replacement, replace every 75,000 miles (120,000 km) or 60 months. Use only Genuine NISSAN Long Life Antifreeze/Coolant (blue) or equivalent with proper mixture ratio of 50% anti-freeze and 50% demineralized or distilled water. Mixing any other type of coolant or the use of non-distilled water will reduce the life expectancy of the factory-fill coolant.

(5) Periodic maintenance is not required. However, if valve noise increases, inspect valve clearance.

* Maintenance items and intervals with "*" are recommended by NISSAN for reliable vehicle operation. The owner need not perform such maintenance in order to maintain the emission warranty or manufacturer recall liability. Other maintenance items and intervals are required.

CHASSIS AND BODY MAINTENANCE

Abbreviations: R = Replace. I = Inspect. Correct or replace if necessary.

MAINTENANCE OPERATION		MAINTENANCE INTERVAL								Reference Section - Page or - Content Title
Perform at number of miles, kilometers or months, whichever comes first.	Miles x 1,000 (km x 1,000) Months	3.75 (6) 3	7.50 (12) 6	11.25 (18) 9	15 (24) 12	18.75 (30) 15	22.5 (36) 18	26.25 (42) 21	30 (48) 24	
Brake lines & cables					I				I	MA-35
Brake fluid					R				R	MA-35
Brake pads & rotors			I		I		I		I	MA-35
CVT fluid	NOTE (1)				I				I	MA-28
Transfer oil & differential gear oil	NOTE (2)				I				I	MA-30 MA-31
Steering gear & linkage, axle & suspension parts			I		I		I		I	MA-36 MA-37
Tire rotation	NOTE (3)									MA-5 MA-32
Propeller shaft (AWD models) & drive shaft boots			I		I		I		I	MA-31 MA-37
Exhaust system			I		I		I		I	MA-28
In-cabin microfilter					R				R	VTL-9

PERIODIC MAINTENANCE

< PERIODIC MAINTENANCE >

MAINTENANCE OPERATION		MAINTENANCE INTERVAL								Reference Section - Page or - Content Title
		Miles x 1,000 (54) 27	37.5 (60) 30	41.25 (66) 33	45 (72) 36	48.75 (78) 39	52.5 (84) 42	56.25 (90) 45	60 (96) 48	
Perform at number of miles, kilometers or months, whichever comes first.	Miles x 1,000 (km x 1,000) Months	33.75 (54) 27	37.5 (60) 30	41.25 (66) 33	45 (72) 36	48.75 (78) 39	52.5 (84) 42	56.25 (90) 45	60 (96) 48	
Brake lines & cables					I				I	MA-35
Brake fluid					R				R	MA-35
Brake pads & rotors			I		I		I		I	MA-35
CVT fluid	NOTE (1)				I				I	MA-28
Transfer oil & differential gear oil	NOTE (2)				I				I	MA-30 MA-31
Steering gear & linkage, axle & suspension parts			I		I		I		I	MA-36 MA-37
Tire rotation	NOTE (3)									MA-5 MA-32
Propeller shaft (AWD models) & drive shaft boots			I		I		I		I	MA-31 MA-37
Exhaust system			I		I		I		I	MA-28
In-cabin microfilter					R				R	VTL-9

NOTE:

- (1) If towing a trailer, using a camper or a car-top carrier, or driving on rough or muddy roads, inspect CVT fluid deterioration with CONSULT every 60,000 miles (96,000 km), then change CVT fluid if necessary. (Refer to [TM-46, "CONSULT Function"](#).) And if CONSULT is not available, change (not just inspect) CVT fluid every 60,000 miles (96,000 km). Using transmission fluid other than Genuine NISSAN CVT Fluid will damage the CVT, which is not covered by the NISSAN new vehicle limited warranty.
- (2) If towing a trailer, using a camper or a car-top carrier, or driving on rough or muddy roads, change (not just inspect) oil at every 30,000 miles (48,000 km) or 24 months.
- (3) Refer to "Tire rotation" under the "GENERAL MAINTENANCE" heading earlier in this section.

FOR NORTH AMERICA : Schedule 2

INFOID:000000007351399

EMISSION CONTROL SYSTEM MAINTENANCE

Abbreviations: R = Replace. I = Inspect. Correct or replace if necessary. []: At the mileage intervals only

MAINTENANCE OPERATION		MAINTENANCE INTERVAL								Reference Section - Page or - Content Title
		Miles x 1,000 (12) 6	15 (24) 12	22.5 (36) 18	30 (48) 24	37.5 (60) 30	45 (72) 36	52.5 (84) 42	60 (96) 48	
Perform at number of miles, kilometers or months, whichever comes first.	Miles x 1,000 (km x 1,000) Months	7.5 (12) 6	15 (24) 12	22.5 (36) 18	30 (48) 24	37.5 (60) 30	45 (72) 36	52.5 (84) 42	60 (96) 48	
Drive belts	NOTE (1)								I*	MA-18
Air cleaner filter					[R]				[R]	MA-24
EVAP vapor lines					I*				I*	MA-27
Fuel lines					I*				I*	MA-24
Fuel filter	NOTE (2)									-
Engine coolant*	NOTE (3)									MA-19
Engine oil		R	R	R	R	R	R	R	R	MA-24
Engine oil filter (Use genuine NISSAN engine oil filter or equivalent.)		R	R	R	R	R	R	R	R	MA-25
Spark plugs (Iridium-tipped type)		Replace every 105,000 miles (168,000 km).								MA-26
Intake & exhaust valve clearance*	NOTE (4)									EM-22

NOTE:

- (1) After 60,000 miles (96,000 km) or 48 months, inspect every 15,000 miles (24,000 km) or 12 months. Replace the drive belts if found damaged or if the auto belt tensioner reading reaches maximum limit.
- (2) Maintenance-free item. For service procedures, refer to FL section.

PERIODIC MAINTENANCE

< PERIODIC MAINTENANCE >

(3) First replacement interval is 105,000 miles (168,000 km) or 84 months. After first replacement, replace every 75,000 miles (120,000 km) or 60 months. Use only Genuine NISSAN Long Life Antifreeze/Coolant (blue) or equivalent with proper mixture ratio of 50% anti-freeze and 50% demineralized or distilled water. Mixing any other type of coolant or the use of non-distilled water will reduce the life expectancy of the factory-fill coolant.

(4) Periodic maintenance is not required. However, if valve noise increases, inspect valve clearance.

* Maintenance items and intervals with “*” are recommended by NISSAN for reliable vehicle operation. The owner need not perform such maintenance in order to maintain the emission warranty or manufacturer recall liability. Other maintenance items and intervals are required.

CHASSIS AND BODY MAINTENANCE

Abbreviations: R = Replace. I = Inspect. Correct or replace if necessary.

MAINTENANCE OPERATION		MAINTENANCE INTERVAL								Reference Section - Page or - Content Title
Perform at number of miles, kilometers or months, whichever comes first.	Miles x 1,000 (km x 1,000) Months	7.5 (12) 6	15 (24) 12	22.5 (36) 18	30 (48) 24	37.5 (60) 30	45 (72) 36	52.5 (84) 42	60 (96) 48	
Brake lines & cables			I		I		I		I	MA-35
Brake fluid					R				R	MA-35
Brake pads & rotors			I		I		I		I	MA-35
CVT fluid	NOTE (1)		I		I		I		I	MA-28
Transfer oil & differential gear oil			I		I		I		I	MA-30 MA-31
Steering gear & linkage, axle & suspension parts					I				I	MA-36 MA-37
Tire rotation	NOTE (2)									MA-5 MA-32
Propeller shaft (AWD models) & drive shaft boots			I		I		I		I	MA-31 MA-37
Exhaust system					I				I	MA-28
In-cabin microfilter			R		R		R		R	VTL-9

NOTE:

(1) Using transmission fluid other than Genuine Nissan CVT Fluid will damage the CVT, which is not covered by the NISSAN new vehicle limited warranty.

(2) Refer to “Tire rotation” under the “GENERAL MAINTENANCE” heading earlier in this section.

FOR MEXICO

FOR MEXICO : Periodic Maintenance

INFOID:000000007351400

The following tables show the normal maintenance schedule. Depending upon weather and atmospheric conditions, varying road surfaces, individual driving habits and vehicle usage, additional or more frequent maintenance may be required.

Periodic maintenance beyond the last period shown on the tables requires similar maintenance.

ENGINE AND EMISSION CONTROL MAINTENANCE

Abbreviations: I = Inspect and correct or replace as necessary, R = Replace, E = Check and correct the engine coolant mixture ratio.

MAINTENANCE OPERATION		MAINTENANCE INTERVAL								Reference page
Perform at number of kilometers (miles) or months, whichever comes first.	km x 1,000 (Miles x 1,000) Months	10 (6) 6	20 (12) 12	30 (18) 18	40 (24) 24	50 (30) 30	60 (36) 36	70 (42) 42	80 (48) 48	
Underhood and under vehicle										
Intake & exhaust valve clearance	See NOTE (1)									EM-22
Drive belts	See NOTE (2)				I				I	MA-18
Engine oil (Use recommended oil.)★		R	R	R	R	R	R	R	R	MA-24
Engine oil filter (Use genuine NISSAN engine oil filter or equivalent)★		R	R	R	R	R	R	R	R	MA-25

PERIODIC MAINTENANCE

< PERIODIC MAINTENANCE >

MAINTENANCE OPERATION	km x 1,000 (Miles x 1,000) Months	MAINTENANCE INTERVAL								Reference page
		10 (6) 6	20 (12) 12	30 (18) 18	40 (24) 24	50 (30) 30	60 (36) 36	70 (42) 42	80 (48) 48	
Perform at number of kilometers (miles) or months, whichever comes first.										
Engine coolant (Use Genuine NISSAN Engine Coolant or equivalent in its quality.)	See NOTE (3)				E				R	MA-19
Cooling system					I				I	MA-18 MA-22 MA-23
Fuel lines					I				I	MA-24
Air cleaner filter (Viscous paper type)★					R				R	MA-24
Fuel filter (In-tank type)	See NOTE (4)									—
Spark plugs (Iridium-tipped type)		Replace every 100,000 km (60,000 miles)								MA-26
EVAP vapor lines (With carbon canister)					I				I	MA-27

NOTE:

- Maintenance items with “★” should be performed more frequently according to “Maintenance Under Severe Driving Conditions”.
- (1) Periodic maintenance is not required. However, if valve noise increases, check valve clearance.
- (2) Replace the drive belts if found damaged or if the auto belt tensioner reading reaches the maximum limit.
- (3) Use Genuine NISSAN Engine Coolant or equivalent in its quality, in order to avoid possible aluminum corrosion within the engine cooling system caused by the use of non-genuine engine coolant. After first replacement, replace every 40,000 km (24,000 miles) or 24 months.
- (4) Maintenance-free item. For service procedures, refer to FL section.

CHASSIS AND BODY MAINTENANCE

Abbreviations: I = Inspect and correct or replace as necessary, R = Replace, L = Lubricate.

MAINTENANCE OPERATION	km x 1,000 (Miles x 1,000) Months	MAINTENANCE INTERVAL								Reference page
		10 (6) 6	20 (12) 12	30 (18) 18	40 (24) 24	50 (30) 30	60 (36) 36	70 (42) 42	80 (48) 48	
Underhood and under vehicle										
Brake line & cables			I		I		I		I	MA-35
Brake fluid (For level & leaks)			I		I		I		I	MA-34
Brake fluid★					R				R	MA-35
CVT fluid (For level & leaks)	See NOTE (1)		I		I		I		I	MA-28
Exhaust system					I				I	MA-28
Transfer oil (For level & leaks)			I		I		I		I	MA-30
Differential gear oil (For level & leaks)★			I		I		I		I	MA-31
Propeller shaft & drive shafts★			I		I		I		I	MA-31 MA-37
Steering gear & linkage, axle & suspension parts★					I				I	MA-36 MA-37
Outside and inside										
Wheel alignment (If necessary, rotate & balance wheels)			I		I		I		I	FSU-7 RSU-6 MA-32
Brake pads, rotors, drums & linings★			I		I		I		I	MA-35 BR-15 BR-17

PERIODIC MAINTENANCE

< PERIODIC MAINTENANCE >

MAINTENANCE OPERATION		MAINTENANCE INTERVAL								Reference page
Perform at number of kilometers (miles) or months, whichever comes first.	km x 1,000 (Miles x 1,000) Months	10 (6) 6	20 (12) 12	30 (18) 18	40 (24) 24	50 (30) 30	60 (36) 36	70 (42) 42	80 (48) 48	
Foot brake & parking brake (For free play, stroke & operation)			I		I		I		I	BR-8 PB-3
Air conditioner filter★			R		R		R		R	VTL-9

NOTE:

- Maintenance items with “★” should be performed more frequently according to “Maintenance Under Severe Driving Conditions”.
- (1) If towing a trailer, using a camper or a car-top carrier, or driving on rough or muddy roads, inspect CVT fluid deterioration with CONSULT every 100,000 km (60,000 miles), then change CVT fluid if necessary. (Refer to [TM-46. "CONSULT Function"](#).) And if CONSULT is not available, change (not just inspect) CVT fluid every 100,000 km (60,000 miles). Using transmission fluid other than Genuine NISSAN CVT Fluid will damage the CVT, which is not covered by the warranty.

MAINTENANCE UNDER SEVERE DRIVING CONDITIONS

The maintenance intervals shown on the preceding pages are for normal operating conditions. If the vehicle is mainly operated under severe driving conditions as shown below, more frequent maintenance must be performed on the following items as shown in the table.

Severe driving conditions

- A — Driving under dusty conditions
- B — Driving repeatedly short distances
- C — Towing a trailer or caravan
- D — Extensive idling
- E — Driving in extremely adverse weather conditions or in areas where ambient temperatures are either extremely low or extremely high
- F — Driving in high humidity or mountainous areas
- G — Driving in areas using salt or other corrosive areas
- H — Driving on rough and/or muddy roads or in the desert
- I — Driving with frequent use of braking or in mountainous areas
- J — Frequent driving in water

Maintenance operation: Inspect. Correct or replace if necessary.

Driving condition										Maintenance item		Maintenance operation	Maintenance interval	Reference page
A	Air cleaner filter	Viscous paper type	Replace	More frequently	MA-24
A	B	C	D	Engine oil & engine oil filter		Replace	Every 5,000 km (3,000 miles) or 3 months	MA-24 MA-25
.	F	Brake fluid		Replace	Every 20,000 km (12,000 miles) or 12 months	MA-35
.	.	C	H	.	.	Differential gear oil		Replace	Every 40,000 km (24,000 miles) or 24 months	MA-31
.	G	H	.	.	Propeller shaft & drive shafts		Inspect	Every 10,000 km (6,000 miles) or 6 months	MA-31 MA-37
.	G	H	.	.	Steering gear & linkage, axle & suspension parts		Inspect	Every 20,000 km (12,000 miles) or 12 months	MA-36 MA-37
A	.	C	.	.	.	G	H	I	.	Brake pads, rotors, drums & linings		Inspect	Every 5,000 km (3,000 miles) or 3 months	MA-35 BR-15 BR-17
A	Air conditioner filter		Replace	More frequently	VTL-9

RECOMMENDED FLUIDS AND LUBRICANTS

< PERIODIC MAINTENANCE >

RECOMMENDED FLUIDS AND LUBRICANTS FOR NORTH AMERICA

FOR NORTH AMERICA : Fluids and Lubricants

INFOID:000000007351401

		Capacity (Approximate)			Recommended Fluids/Lubricants
		US measure	Imp measure	Liter	
Engine oil Drain and refill	With oil filter change	5-1/8 qt	4-1/4 qt	4.8	Engine oil with API Certification Mark* ¹ Viscosity SAE 5W-30
	Without oil fil- ter change	4-3/4 qt	4 qt	4.5	
Dry engine (Overhaul)		5-3/4 qt	4-3/4 qt	5.4	
Cooling system	With reservoir tank	7-3/4 qt	6-3/8 qt	7.3	Pre-diluted Genuine NISSAN Long Life Anti- freeze/Coolant (blue) or equivalent
	Reservoir tank	3/4 qt	5/8 qt	0.75	
CVT fluid	2WD	Without fluid cooler	7-3/4 qt	6-3/8 qt	Genuine NISSAN CVT Fluid NS-2 * ²
		With fluid cooler	7-7/8 qt	6-5/8 qt	
	AWD	Without fluid cooler	8-3/4 qt	7-1/4 qt	
		With fluid cooler	9 qt	7-1/2 qt	
Differential gear oil		1-1/8 pt	1 pt	0.55	Genuine NISSAN Differential Oil Hypoid Su- per GL-5 80W-90 or API GL-5, Viscosity SAE 80W-90 * ³
Transfer oil		3/4 pt	5/8 pt	0.36	Genuine NISSAN Differential Oil Hypoid Su- per GL-5 80W-90 or API GL-5, Viscosity SAE 80W-90
Brake fluid		—	—	—	Genuine NISSAN Super Heavy Duty Brake Fluid* ⁴ or equivalent DOT 3 (US FMVSS No. 116)
Multi-purpose grease		—	—	—	NLGI No. 2 (Lithium soap base)
Windshield washer fluid		—	—	—	Genuine NISSAN Windshield Washer Con- centrate Cleaner & Antifreeze or equivalent
Fuel recommendation		—	—	—	Refer to GI-34. "Fuel"

*1: For additional information, see "Engine Oil Recommendation".

*2: Use only Genuine NISSAN CVT Fluid NS-2. Using transmission fluid other than Genuine NISSAN CVT Fluid NS-2 will damage the CVT, which is not covered by the NISSAN new vehicle limited warranty.

*3: For hot climates, viscosity SAE 90 is suitable for ambient temperatures above 32°F (0°C).

*4: Available in mainland U.S.A. through a NISSAN dealer.

FOR NORTH AMERICA : Engine Oil Recommendation

INFOID:000000007351402

NISSAN recommends the use of an energy conserving oil in order to improve fuel economy. Select only engine oils that meet the American Petroleum Institute (API) certification and International Lubricant Standardization and Approval Committee (ILSAC) certification and SAE viscosity standard. These oils have the API certification mark on the front of the container. Oils which do not have the specified quality label should not be used as they could cause engine damage.

A
B
C
D
E
F
G
H
I
J
K
L
M
N
O

MA

RECOMMENDED FLUIDS AND LUBRICANTS

< PERIODIC MAINTENANCE >

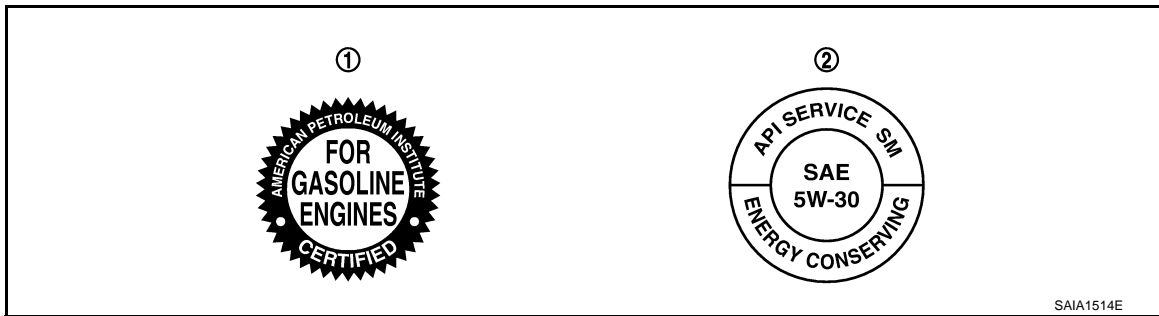

1. API certification mark

2. API service symbol

FOR NORTH AMERICA : Anti-Freeze Coolant Mixture Ratio

INFOID:000000007351403

The engine cooling system is filled at the factory with a high-quality, year-round, anti-freeze coolant solution. The anti-freeze solution contains rust and corrosion inhibitors. Therefore, additional cooling system additives are not necessary.

For outside temperatures down to:		Genuine NISSAN Anti-freeze Coolant (blue) or equivalent	Demineralized water or distilled water
°C	°F		
-35	-30	50%	50%

CAUTION:

When adding or replacing coolant, be sure to use only Genuine NISSAN Long Life Antifreeze/Coolant (blue) or equivalent with the proper mixture ratio of 50% anti-freeze and 50% demineralized or distilled water.

Mixing any other type of coolant or the use of non-distilled water will reduce the life expectancy of the factory-fill coolant.

FOR MEXICO

FOR MEXICO : Fluids and Lubricants

INFOID:000000007351404

		Capacity (Approximate)		Recommended Fluids/Lubricants
		Liter	Imp measure	
Engine oil Drain and re-fill	With oil filter change	4.8	4-1/4 qt	Genuine NISSAN engine oil*1 API grade SL or SM*1 ILSAC grade GF-2, GF-3 or GF-4*1 Viscosity SAE 10W-30
	Without oil filter change	4.5	4 qt	
Dry engine (engine overhaul)		5.4	4-3/4 qt	
Cooling system (with reservoir)		7.3	6-3/8 qt	Genuine NISSAN Engine Coolant or equivalent in its quality*2
Reservoir tank		0.75	5/8 qt	
Transfer oil		0.36	5/8 pt	Genuine NISSAN Differential Oil Hypoid Super GL-5 80W-90 or API GL-5, Viscosity SAE 80W-90
Differential gear oil		0.55	1 pt	
CVT fluid	2WD	7.5	6-5/8 qt	Genuine NISSAN CVT fluid NS-2*3
	4WD	8.5	7-1/2 qt	
Brake fluid		—	—	Genuine NISSAN Brake Fluid, or equivalent DOT 3 (US FMVSS No. 116)
Multi-purpose grease		—	—	NLGI No. 2 (Lithium soap base)

*1: For additional information, see "SAE Viscosity Number".

*2: Use Genuine NISSAN Engine Coolant or equivalent in its quality, in order to avoid possible aluminum corrosion within the engine cooling system caused by the use of non-genuine engine coolant.

Note that any repairs for the incidents within the engine cooling system while using non-genuine engine coolant may not be covered by the warranty even if such incidents occurred during the warranty period.

RECOMMENDED FLUIDS AND LUBRICANTS

< PERIODIC MAINTENANCE >

*3: Use only Genuine NISSAN CVT fluid NS-2. Using transmission fluid other than Genuine NISSAN CVT fluid NS-2 will damage the CVT, which is not covered by the warranty.

FOR MEXICO : SAE Viscosity Number

INFOID:000000007351405

GASOLINE ENGINE

- 10W-30 is preferable.
5W-30 is also preferable and will improve fuel economy.
If 10W-30 or 5W-30 is not available, select the viscosity, from the chart, that is suitable for the outside temperature range.

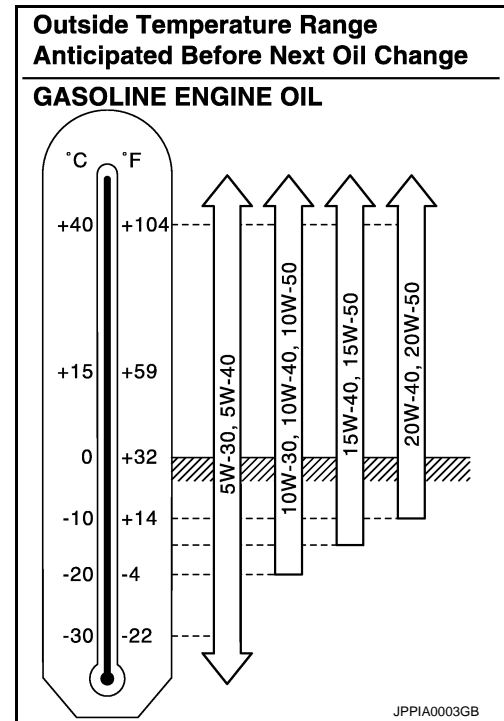

FOR MEXICO : Engine Coolant Mixture Ratio

INFOID:000000007351406

The engine cooling system is filled at the factory with a high-quality, year-round and extended life engine coolant. The high quality engine coolant contains the specific solutions effective for the anti-corrosion and the anti-freeze function. Therefore, additional cooling system additives are not necessary.

CAUTION:

- When adding or replacing coolant, be sure to use only Genuine NISSAN Engine Coolant or equivalent in its quality with the proper mixture ratio. See the examples shown right.

The use of other types of engine coolant may damage the engine cooling system.

- When checking the engine coolant mixture ratio by the coolant hydrometer, use the chart below to correct your hydrometer reading (specific gravity) according to coolant temperature.

Mixed coolant specific gravity

Outside temperature down to		Composition	
°C	°F	Engine coolant (Concentrated)	Demineralized water or distilled water
-15	5	30%	70%
-35	-30	50%	50%

SMA089D

Unit: specific gravity

Engine coolant mixture ratio	Coolant temperature °C (°F)			
	15 (59)	25 (77)	35 (95)	45 (113)
30%	1.046 - 1.050	1.042 - 1.046	1.038 - 1.042	1.033 - 1.038
50%	1.076 - 1.080	1.070 - 1.076	1.065 - 1.071	1.059 - 1.065

WARNING:

Never remove the radiator cap when the engine is hot. Serious burns could be caused by high pressure fluid escaping from the radiator. Wait until the engine and radiator cool down.

ENGINE MAINTENANCE

< PERIODIC MAINTENANCE >

ENGINE MAINTENANCE

DRIVE BELTS

DRIVE BELTS : Exploded View

INFOID:000000007351407

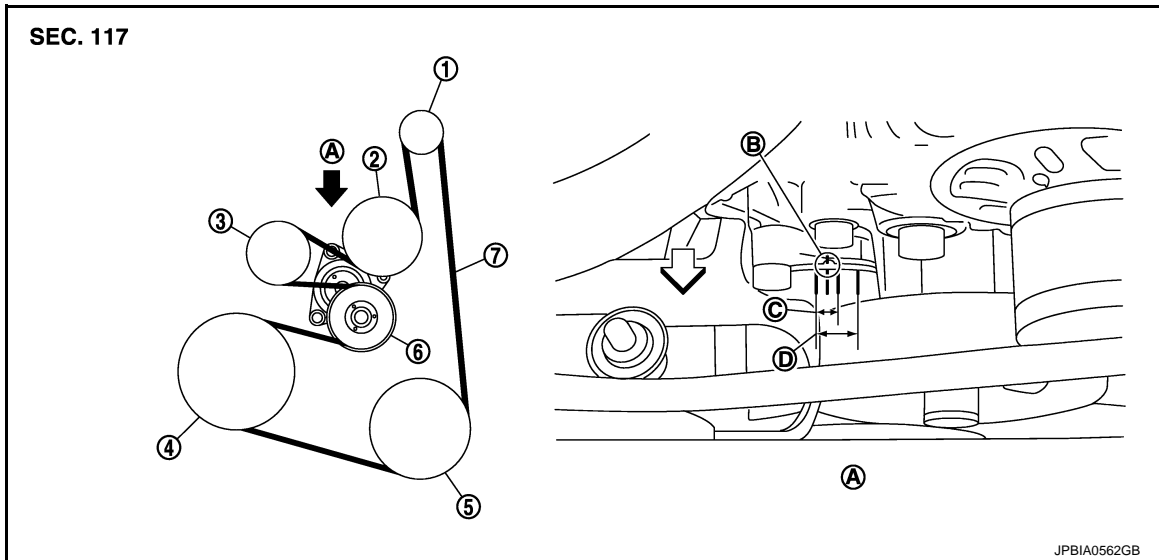

- | | | |
|----------------------|-------------------|------------------------------|
| 1. Alternator | 2. Water pump | 3. Idler pulley |
| 4. Crankshaft pulley | 5. A/C compressor | 6. Drive belt auto-tensioner |
| 7. Drive belt | | |
- A. View A B. Indicator (notch on the fixed side) C. Range when new drive belt is installed
- D. Possible use range
- ↶ : Engine front

DRIVE BELTS : Checking

INFOID:000000007351408

WARNING:

Be sure to perform this step when the engine is stopped.

- Check that the indicator (notch on fixed side) of drive belt auto-tensioner is within the possible use range (between four line notches on moving side).

NOTE:

- Check the drive belt auto-tensioner indication when the engine is cold.
- When new drive belt is installed, the indicator (notch on fixed side) should be within the range (C) in the figure.
- Visually check entire drive belt for wear, damage or cracks.
- If the indicator (notch on fixed side) is out of the possible use range or belt is damaged, replace drive belt.

DRIVE BELTS : Tension Adjustment

INFOID:000000007351409

Refer to : [EM-118, "Drive belt"](#).

ENGINE COOLANT

ENGINE COOLANT : Inspection

INFOID:000000007351410

LEVEL

ENGINE MAINTENANCE

< PERIODIC MAINTENANCE >

- Check that the reservoir tank engine coolant level is within the "MIN" to "MAX" when the engine is cool.

A : MAX

B : MIN

- Adjust the engine coolant level if necessary.

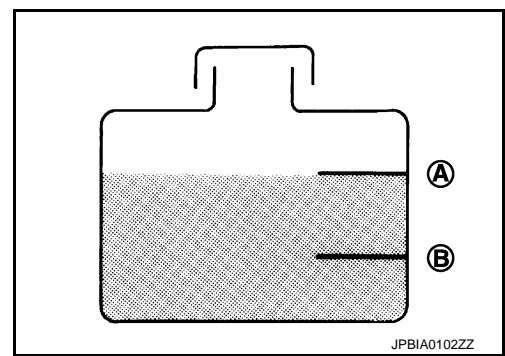

LEAKAGE

- To check for leakage, apply pressure to the cooling system with the radiator cap tester (commercial service tool) (A) and the radiator cap tester adapter (commercial service tool) (B).

Testing pressure: Refer to [CO-28, "Radiator"](#).

WARNING:

Never remove radiator cap when engine is hot. Serious burns may occur from high-pressure engine coolant escaping from radiator.

CAUTION:

Higher test pressure than specified may cause radiator damage.

NOTE:

In a case that engine coolant decreases, replenish radiator with engine coolant.

- If anything is found, repair or replace damaged parts.

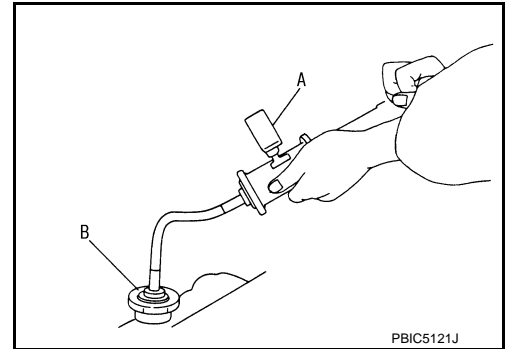

ENGINE COOLANT : Draining

INFOID:000000007351411

WARNING:

- Never remove radiator cap when engine is hot. Serious burns may occur from high-pressure engine coolant escaping from radiator.
- Wrap a thick cloth around the radiator cap. Slowly turn it a quarter of a turn to release built-up pressure. Then turn it all the way.

1. Remove engine under cover.
2. Open radiator drain plug at the bottom of radiator, and then remove radiator cap.

A : Radiator drain plug hole

⇐ : Vehicle front

CAUTION:

Perform this step when engine is cold.

- When draining all of engine coolant in the system, open water drain plugs on cylinder block. Refer to [EM-93, "Exploded View"](#).

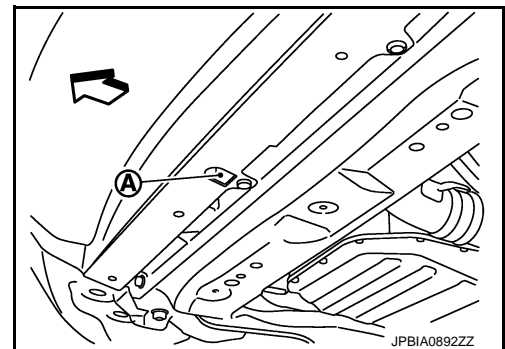

3. Remove reservoir tank if necessary, and drain engine coolant and clean reservoir tank before installing.

MA

ENGINE MAINTENANCE

< PERIODIC MAINTENANCE >

- Move reservoir tank (3), and then remove it numerical order as shown in the figure.

↔ : Vehicle front

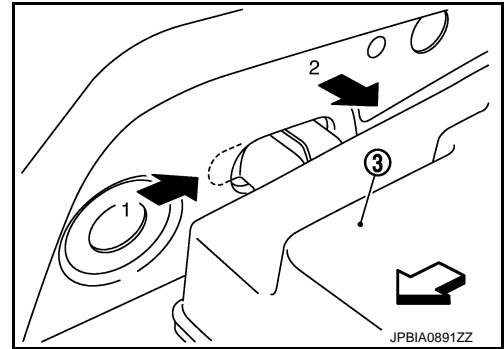

4. Check drained engine coolant for contaminants such as rust, corrosion or discoloration. If contaminated, flush the engine cooling system. Refer to [MA-21, "ENGINE COOLANT : Flushing"](#).

ENGINE COOLANT : Refilling

INFOID:000000007351412

1. Install reservoir tank if removed and radiator drain plug.

CAUTION:

Be sure to clean drain plug and install with new O-ring.

Radiator drain plug: Refer to [CO-17, "Exploded View"](#).

- If water drain plugs on cylinder block are removed, close and tighten them. Refer to [EM-93, "Exploded View"](#).
2. Check that each hose clamp has been firmly tightened.
 3. Remove air duct assembly, and move electric throttle control actuator to aside. Refer to [EM-29, "Exploded View"](#) and [EM-31, "Exploded View"](#).
 4. Disconnect heater hose (1) at the position (↔) in the figure.

↔ : Vehicle front

- Lift up the heater hose end approximately 100 mm (3.94 in) (a) higher than the height at installation.

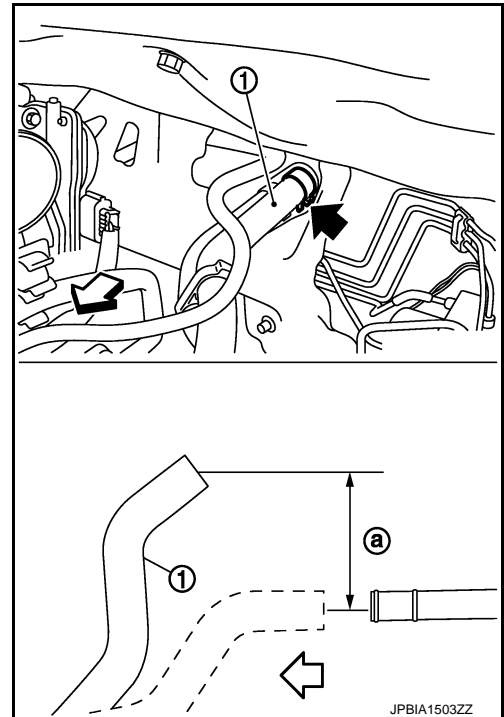

ENGINE MAINTENANCE

< PERIODIC MAINTENANCE >

5. Fill radiator (1) to specified level.

CAUTION:

Never adhere the engine coolant to electronic equipments (alternator etc.).

- Pour engine coolant through engine coolant filler neck slowly of less than 2 ℓ (2-1/8 US qt, 1-3/4 Imp qt) a minute to allow air in system to escape.
- When engine coolant overflows disconnected heater hose, connect heater hose, and continue filling the engine coolant.
- Use Genuine NISSAN Long Life Antifreeze/Coolant or equivalent mixed with water (distilled or demineralized). Refer to [MA-15, "FOR NORTH AMERICA : Fluids and Lubricants"](#) (Except for Mexico) or [MA-16, "FOR MEXICO : Fluids and Lubricants"](#) (for Mexico).

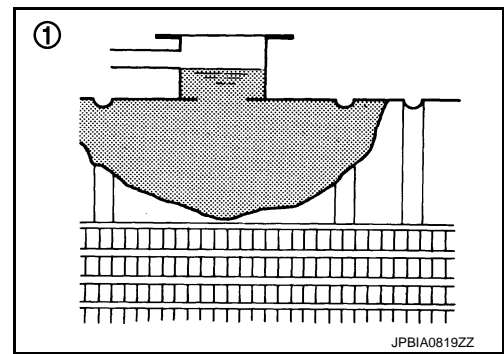

**Engine coolant capacity
(With reservoir tank at "MAX" level)**

Refer to [CO-28, "Periodical Maintenance Specification"](#).

6. Refill reservoir tank to "MAX" level line with engine coolant.

- A : MAX
B : MIN

**Reservoir tank engine coolant capacity
(At "MAX" level)**

Refer to [CO-28, "Periodical Maintenance Specification"](#).

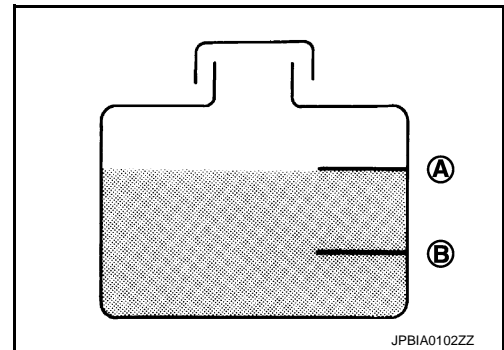

7. Install radiator cap.
8. Install air duct assembly and electric throttle control actuator. Refer to [EM-29, "Exploded View"](#) and [EM-31, "Exploded View"](#).
9. Warm up engine until opening thermostat. Standard for warming-up time is approximately 10 minutes at 3,000 rpm.
- Check thermostat opening condition by touching radiator hose (lower) to see a flow of warm water.
- CAUTION:**
Watch water temperature gauge so as not to overheat engine.
10. Stop the engine and cool down to less than approximately 50°C (122°F).
- Cool down using fan to reduce the time.
 - If necessary, refill radiator up to filler neck with engine coolant.
- CAUTION:**
Never adhere the engine coolant to electronic equipments (alternator etc.).
11. Refill reservoir tank to "MAX" level line with engine coolant.
12. Repeat steps 5 through 10 two or more times with radiator cap installed until engine coolant level no longer drops.
13. Check cooling system for leakage with engine running.
14. Warm up the engine, and check for sound of engine coolant flow while running engine from idle up to 3,000 rpm with heater temperature controller set at several position between "COOL" and "WARM".
- Sound may be noticeable at heater unit.
15. Repeat step 14 three times.
16. If sound is heard, bleed air from cooling system by repeating step 5 through 10 until engine coolant level no longer drops.

ENGINE COOLANT : Flushing

INFOID:000000007351413

1. Install reservoir tank if removed and radiator drain plug.

CAUTION:

Be sure to clean drain plug and install with new O-ring.

A
B
C
D
E
F
G
H
I
J
K
L
M
N
O

MA

ENGINE MAINTENANCE

< PERIODIC MAINTENANCE >

Radiator drain plug : Refer to [CO-17, "Exploded View"](#).

- If water drain plugs on cylinder block are removed, close and tighten them. Refer to [EM-93, "Exploded View"](#).
2. Remove air duct assembly and move electric throttle control actuator to aside. Refer to [EM-29, "Exploded View"](#) and [EM-31, "Exploded View"](#).
3. Disconnect heater hose (1) at the position (←) in the figure.

← : Vehicle front

- Lift up the heater hose end approximately 100 mm (3.94 in) (a) higher than the height at installation.

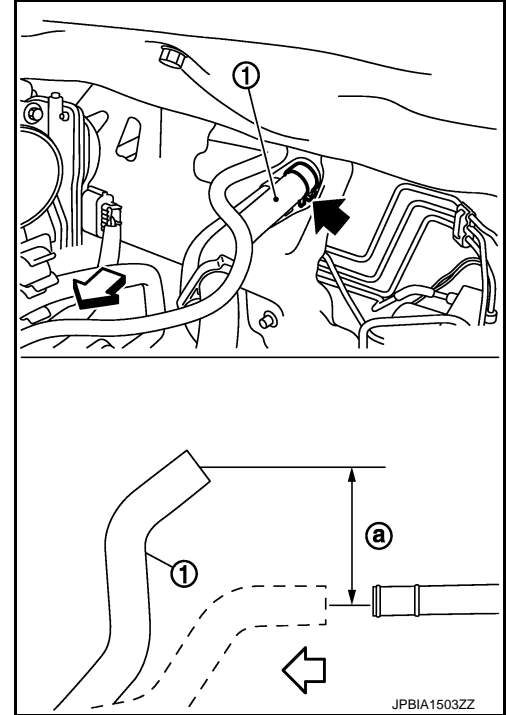

4. Fill radiator and reservoir tank with water and reinstall radiator cap.
 - When engine coolant overflows disconnected heater hose, connect heater hose, and continue filling the engine coolant.
5. Install air duct assembly and electric throttle control actuator. Refer to [EM-29, "Exploded View"](#) and [EM-31, "Exploded View"](#).
6. Run the engine and warm it up to normal operating temperature.
7. Rev the engine two or three times under no-load.
8. Stop the engine and wait until it cools down.
9. Drain water from the system. Refer to [MA-19, "ENGINE COOLANT : Draining"](#).
10. Repeat steps 1 through 9 until clear water begins to drain from radiator.

RADIATOR CAP

RADIATOR CAP : Inspection

INFOID:000000007351414

- Check valve seat of radiator cap.

A : Valve seat
B : Metal plunger

- Check that valve seat is swollen to the extent that the edge of the plunger cannot be seen when watching it vertically from the top.
- Check that valve seat has no soil and damage.

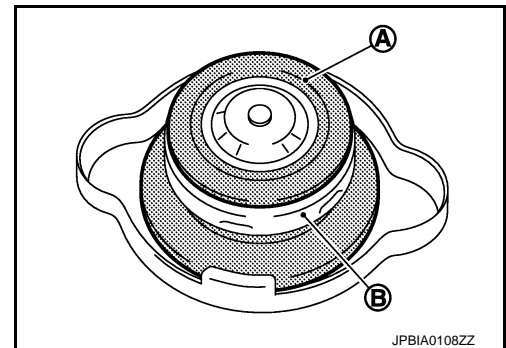

ENGINE MAINTENANCE

< PERIODIC MAINTENANCE >

- Pull negative-pressure valve to open it, and check that it close completely when released.
- Check that there is no dirt or damage on the valve seat of radiator cap negative-pressure valve.
- Check that there are no unusualness in the opening and closing conditions of negative-pressure valve.

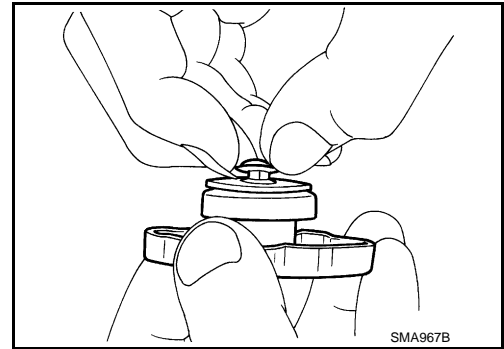

- Check radiator cap relief pressure.

Standard and Limit: Refer to CO-28, "Radiator".

- When connecting radiator cap to the radiator cap tester (commercial service tool) (A) and the radiator cap tester adapter (commercial service tool) (B), apply engine coolant to the cap seal surface.

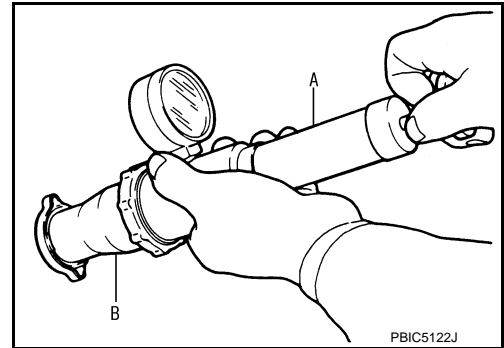

- Replace radiator cap if there is an unusualness related to the above three.

CAUTION:

When installing radiator cap, thoroughly wipe out the radiator filler neck to remove any waxy residue or foreign material.

RADIATOR

RADIATOR : Inspection

INFOID:000000007351415

Check radiator for mud or clogging. If necessary, clean radiator as follows.

CAUTION:

- **Be careful not to bend or damage radiator fins.**
 - **When radiator is cleaned without removal, remove all surrounding parts such as radiator cooling fan assembly and horns. Then tape harness and harness connectors to prevent water from entering.**
1. Apply water by hose to the back side of the radiator core vertically downward.
 2. Apply water again to all radiator core surfaces once per minute.
 3. Stop washing if any stains no longer flow out from radiator.
 4. Blow air into the back side of radiator core vertically downward.
 - Use compressed air lower than 490 kPa (5 kg/cm², 71 psi) and keep distance more than 30 cm (11.81 in).
 5. Blow air again into all the radiator core surfaces once per minute until no water sprays out.

FUEL LINES

A
B
C
D
E
F
G
H
I
J
K
L
M
N
O

MA

ENGINE MAINTENANCE

< PERIODIC MAINTENANCE >

FUEL LINES : Inspection

INFOID:000000007351416

Inspect fuel lines, fuel filler cap and, fuel tank for improper attachment, leakage, cracks, damage, loose connections, chafing or deterioration.

- A : Engine
- B : Fuel line
- C : Fuel tank

If necessary, repair or replace damaged parts.

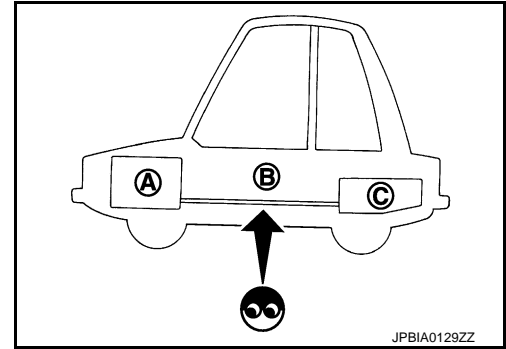

AIR CLEANER FILTER

AIR CLEANER FILTER : Removal and Installation

INFOID:000000007351417

REMOVAL

1. Push the tabs (A) of both ends of the air cleaner cover (1) into the inside (B).
2. Pull up the air cleaner cover forward (C) and remove it.

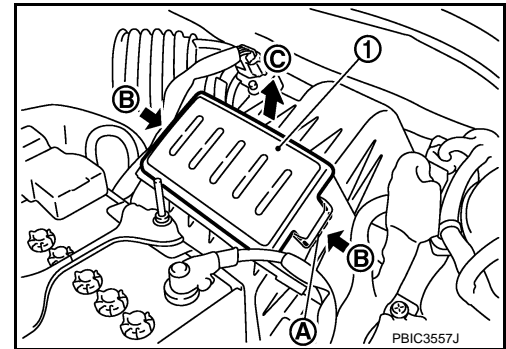

3. Remove the air cleaner filter (1) and holder (2) assembly from the air cleaner case.
4. Remove the air cleaner filter from the holder.

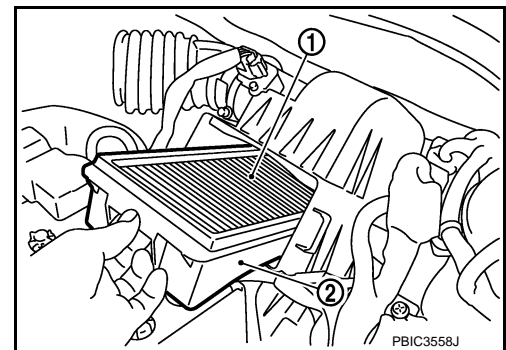

INSTALLATION

Install in the reverse order of removal.

ENGINE OIL

ENGINE OIL : Draining

INFOID:000000007351418

WARNING:

- Be careful not to get burn yourself, as engine oil may be hot.
- Prolonged and repeated contact with used engine oil may cause skin cancer. Try to avoid direct skin contact with used engine oil. If skin contact is made, wash thoroughly with soap or hand cleaner as soon as possible.

1. Warm up the engine, and check for engine oil leakage from engine components. Refer to [LU-5. "Inspection"](#).
2. Stop the engine and wait for 10 minutes.
3. Loosen oil filler cap.

ENGINE MAINTENANCE

< PERIODIC MAINTENANCE >

4. Remove drain plug (1) and then drain engine oil.

← : Vehicle front

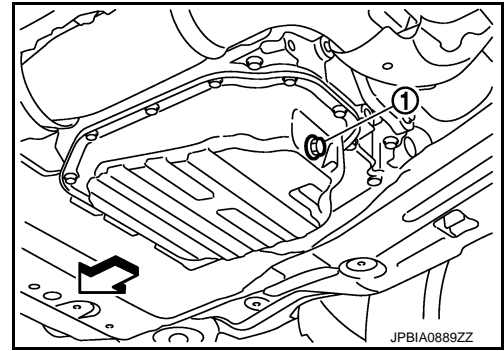

INFOID:000000007351419

ENGINE OIL : Refilling

1. Install drain plug with new drain plug washer. Refer to [EM-37, "Exploded View"](#).

CAUTION:

Be sure to clean drain plug and install with new drain plug washer.

Tightening torque : Refer to [EM-37, "Exploded View"](#).

2. Refill with new engine oil.
Engine oil specification and viscosity: Refer to [MA-15, "FOR NORTH AMERICA : Fluids and Lubricants"](#) (Except for Mexico) or [MA-16, "FOR MEXICO : Fluids and Lubricants"](#) (for Mexico).

Engine oil capacity : Refer to [LU-14, "Periodical Maintenance Specification"](#).

CAUTION:

- The refill capacity depends on the engine oil temperature and drain time. Use these specifications for reference only.
- Always use oil level gauge to determine the proper amount of engine oil in engine.

3. Warm up the engine and check area around drain plug and oil filter for engine oil leakage.
4. Stop the engine and wait for 10 minutes.
5. Check the engine oil level. Refer to [LU-5, "Inspection"](#).

OIL FILTER

OIL FILTER : Removal and Installation

INFOID:000000007351420

REMOVAL

1. Remove splash guard. Refer to [EXT-22, "Exploded View"](#).
2. Using oil filter wrench [SST: KV10115801 (J-38956)] (A), remove oil filter.

← : Vehicle front

CAUTION:

- Oil filter is provided with relief valve. Use genuine NISSAN oil filter or equivalent.
- Be careful not to get burned when engine and engine oil may be hot.
- When removing, prepare a shop cloth to absorb any engine oil leakage or spillage.
- Never allow engine oil to adhere to drive belt.
- Completely wipe off any engine oil that adheres to engine and vehicle.

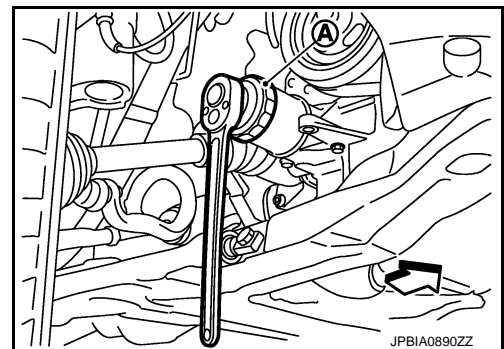

INSTALLATION

1. Remove foreign materials adhering to oil filter installation surface.

ENGINE MAINTENANCE

< PERIODIC MAINTENANCE >

2. Apply new engine oil to the oil seal contact surface of new oil filter.

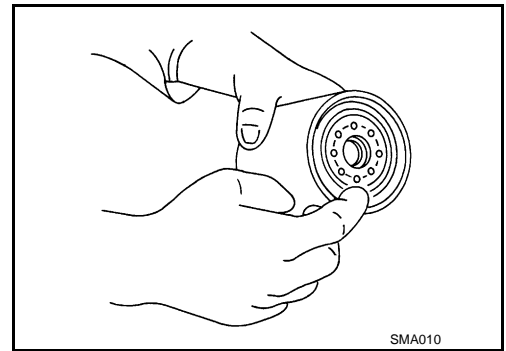

3. Screw oil filter manually until it touches the installation surface, then tighten it by 2/3 turn (A). Or tighten to the specification.

Oil filter:

 : 17.6 N·m (1.8 kg-m, 13 ft-lb)

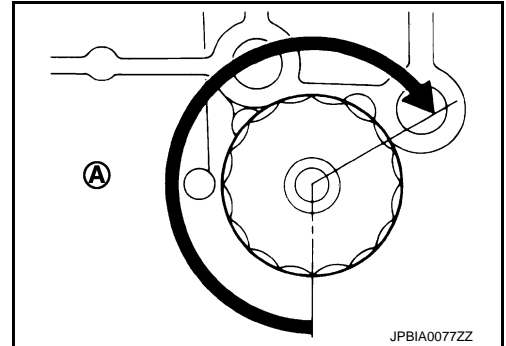

OIL FILTER : Inspection

INFOID:000000007351421

INSPECTION AFTER INSTALLATION

1. Check the engine oil level. Refer to [LU-5, "Inspection"](#).
2. Start the engine, and check there is no leakage of engine oil.
3. Stop the engine and wait for 10 minutes.
4. Check the engine oil level, and adjust the level. Refer to [LU-5, "Inspection"](#).

SPARK PLUG

SPARK PLUG : Removal and Installation

INFOID:000000007351422

REMOVAL

1. Remove ignition coil. Refer to [EM-44, "Removal and Installation"](#).
2. Remove spark plug with spark plug wrench (commercial service tool).

CAUTION:

Never drop or shock spark plug.

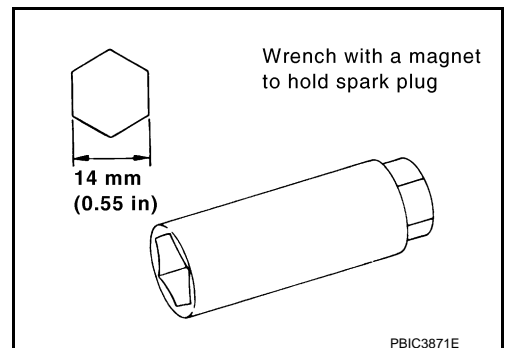

INSTALLATION

Install in the reverse order of removal.

SPARK PLUG : Inspection

INFOID:000000007351423

INSPECTION AFTER REMOVAL

Use standard type spark plug for normal condition.

ENGINE MAINTENANCE

< PERIODIC MAINTENANCE >

Spark plug (standard) : Refer to [EM-118, "Spark Plug"](#).

CAUTION:

- Never drop or shock spark plug.
- Never use wire brush for cleaning.
- If plug tip is covered with carbon, spark plug cleaner may be used.

Cleaner air pressure: Less than 588 kPa (6 kg/cm², 85 psi)

Cleaning time: Less than 20 seconds

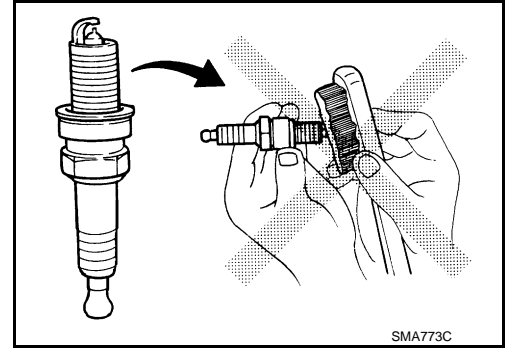

- Checking and adjusting plug gap is not required between change intervals.

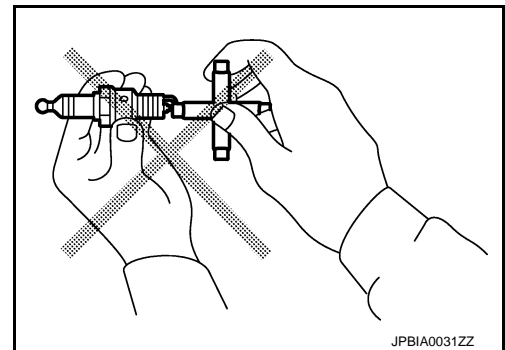

EVAP VAPOR LINES

EVAP VAPOR LINES : Inspection

Except for Mexico, refer to [EC-461, "Inspection"](#).
For Mexico, refer to [EC-800, "Inspection"](#).

INFOID:000000007351424

A
B
C
D
E
F
G
H
I
J
K
L
M
N
O
MA

CHASSIS MAINTENANCE

< PERIODIC MAINTENANCE >

CHASSIS MAINTENANCE EXHAUST SYSTEM

EXHAUST SYSTEM : Inspection

INFOID:000000007351425

Check exhaust pipes, muffler, and mounting for improper attachment, leakage, cracks, damage or deterioration.

- If anything is found, repair or replace damaged parts.

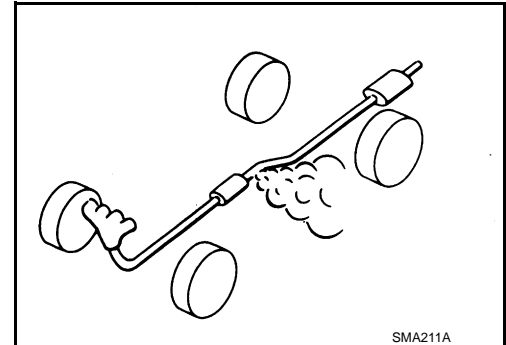

CVT FLUID

CVT FLUID : Inspection

INFOID:00000000734080

CHECKING CVT FLUID

The fluid level should be checked with the fluid warmed up to 50 to 80°C (122 to 176°F). The fluid level check procedure is as follows:

1. Check for fluid leakage.
2. With the engine warmed up, drive the vehicle in an urban area. When ambient temperature is 20°C (68°F), it takes about 10 minutes for the CVT fluid to warm up to 50 to 80°C (122 to 176°F).
3. Park the vehicle on a level surface.
4. Apply parking brake firmly.
5. With engine at idle, while depressing brake pedal, shift selector lever throughout the entire shift range.
6. Pull out the CVT fluid level gauge from the CVT fluid charging pipe after pressing the tab on the CVT fluid level gauge to release the lock.

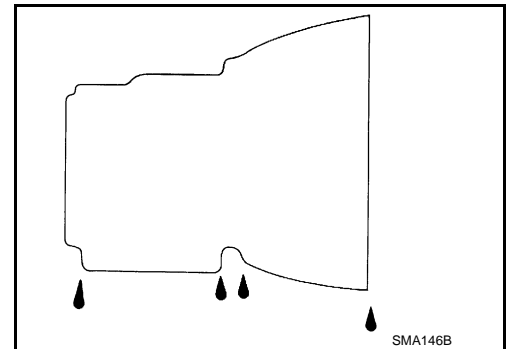

7. Wipe fluid off the CVT fluid level gauge. Insert the CVT fluid level gauge rotating 180° from the originally installed position, then securely push the CVT fluid level gauge until it meets the top end of the CVT fluid charging pipe.

CAUTION:

When wiping away the CVT fluid level gauge, always use lint-free paper, not a cloth rag.

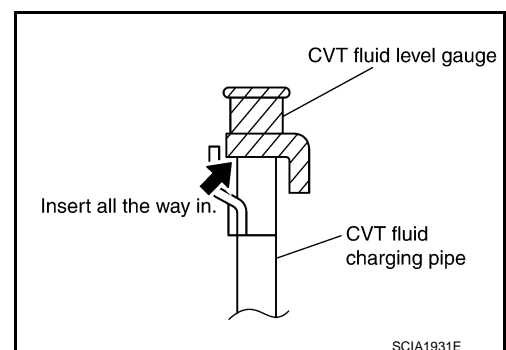
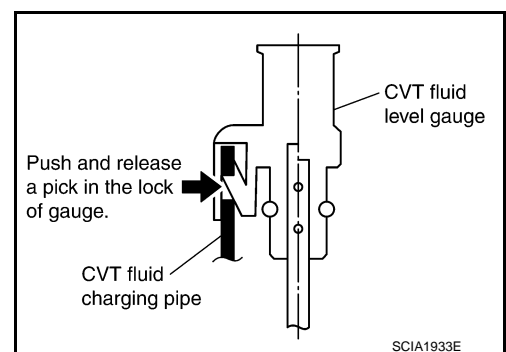

CHASSIS MAINTENANCE

< PERIODIC MAINTENANCE >

- Place the selector lever in "P" or "N" and check that the fluid level is within the specified range.

CAUTION:

When reinstalling CVT fluid level gauge, insert it into the CVT fluid charging pipe and rotate it to the original installation position until securely locked.

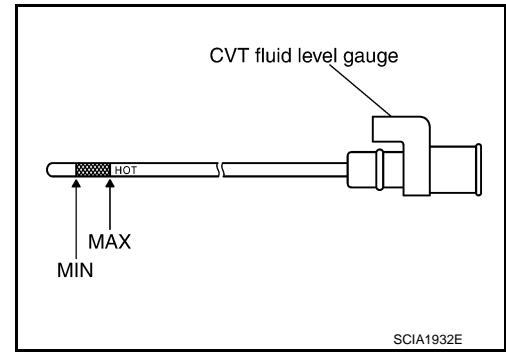

CVT FLUID CONDITION

Check CVT fluid condition.

- If CVT fluid is very dark or smells burned, check operation of CVT. Flush cooling system after repair of CVT.
- If CVT fluid contains frictional material (clutches, brakes, etc.), replace radiator and flush cooler line using cleaning solvent and compressed air after repair of CVT. Refer to [TM-206. "FLUID COOLER : Exploded view"](#) (with fluid cooler), [TM-159. "Cleaning"](#).

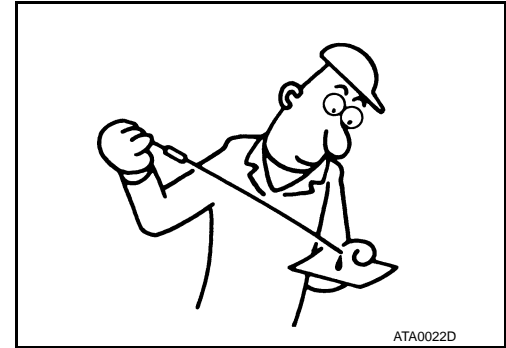

Fluid status	Conceivable cause	Required operation
Varnished (viscous varnish state)	CVT fluid become degraded due to high temperatures.	Replace the CVT fluid and check the CVT main unit and the vehicle for malfunctions (wire harnesses, cooler pipes, etc.)
Milky white or cloudy	Water in the fluid	Replace the CVT fluid and check for places where water is getting in.
Large amount of metal powder mixed in	Unusual wear of sliding parts within CVT	Replace the CVT fluid and check for improper operation of the CVT.

CVT FLUID : Changing

INFOID:000000007734081

- Remove drain plug from oil pan and then the CVT fluid.
- Remove drain plug gasket from drain plug.
- Install drain plug gasket to drain plug
CAUTION:
Never reuse drain plug gasket.
- Install drain plug to oil pan. Refer to [TM-184. "Exploded View"](#).
- Fill CVT fluid from CVT fluid charging pipe to the specified level.

CVT fluid : Refer to [TM-219. "General Specification"](#).

Fluid capacity : Refer to [TM-219. "General Specification"](#).

CAUTION:

- Use only Genuine NISSAN CVT Fluid NS-2. Never mix with other fluid.
- Using CVT fluid other than Genuine NISSAN CVT Fluid NS-2 will deteriorate in driveability and CVT durability, and may damage the CVT, which is not covered by the warranty.
- When filling CVT fluid, take care not to scatter heat generating parts such as exhaust.
- Sufficiently shake the container of CVT fluid before using.
- Delete CVT fluid deterioration date with CONSULT after changing CVT fluid. Refer to [TM-46. "CONSULT Function"](#).

- With the engine warmed up, drive the vehicle in an urban area.

NOTE:

When ambient temperature is 20°C (68°F), it takes about 10 minutes for the CVT fluid to warm up to 50 to 80°C (122 to 176°F).

A
B
C
D
E
F
G
H
I
J
K
L
M
N
O

MA

CHASSIS MAINTENANCE

< PERIODIC MAINTENANCE >

7. Check CVT fluid level and condition.
8. Repeat steps 1 to 5 if CVT fluid has been contaminated.

TRANSFER OIL

TRANSFER OIL : Inspection

INFOID:000000007351428

OIL LEAKAGE

Check transfer surrounding area (oil seal, drain plug, filler plug, and transfer case, etc.) for oil leakage.

OIL LEVEL

1. Remove filler plug (1) and gasket. Then check that oil is filled up (A) from mounting hole for the filler plug.
2. Before installing filler plug, set a new gasket. Install filler plug on transfer and tighten to the specified torque. Refer to [DLN-58, "Exploded View"](#).

CAUTION:

Never reuse gaskets.

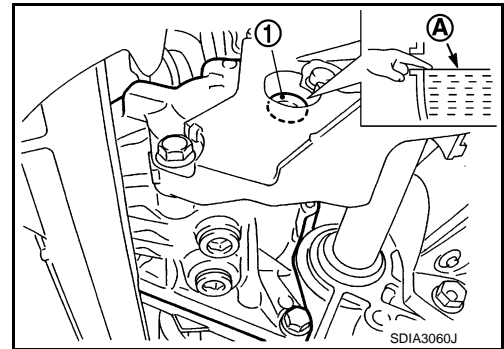

TRANSFER OIL : Draining

INFOID:000000007351429

1. Run the vehicle to warm up the transfer unit sufficiently.
2. Stop the engine and remove drain plug (1) and gaskets to drain the transfer oil.

CAUTION:

Never remove tooth contact test hole plug (2).

3. Before installing drain plug, set a new gasket. Install drain plug on transfer and tighten to the specified torque. Refer to [DLN-58, "Exploded View"](#).

CAUTION:

Never reuse gaskets.

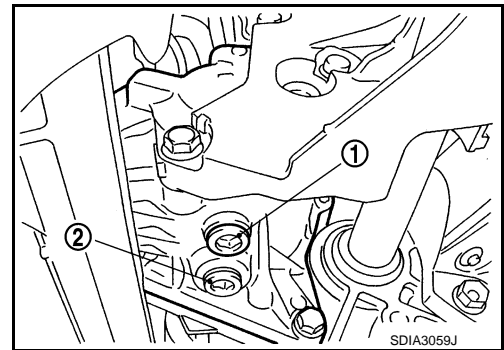

TRANSFER OIL : Refilling

INFOID:000000007351430

1. Remove filler plug (1) and gasket. Then fill oil up to mounting hole (A) for the filler plug.

Oil grade and viscosity

: Refer to [MA-15, "FOR NORTH AMERICA : Fluids and Lubricants"](#) (for NORTH AMERICA), [MA-16, "FOR MEXICO : Fluids and Lubricants"](#) (for MEXICO).

Oil capacity

: Refer to [DLN-81, "General Specifications"](#).

CAUTION:

Carefully fill the oil. (Fill up for approximately 3 minutes.)

2. Leave the vehicle for 3 minutes. Then check oil level again.
3. Before installing filler plug, set a new gasket. Install filler plug on transfer and tighten to the specified torque. Refer to [DLN-58, "Exploded View"](#).

CAUTION:

Never reuse gasket.

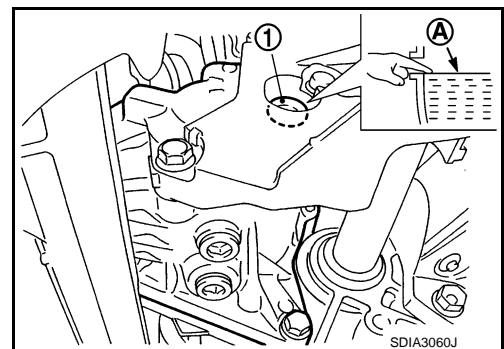

CHASSIS MAINTENANCE

< PERIODIC MAINTENANCE >

REAR PROPELLER SHAFT

REAR PROPELLER SHAFT : Inspection

INFOID:000000007687371

NOISE

- Check the propeller shaft tube surface for dents or cracks. If damaged, replace propeller shaft assembly.
- If center bearing is noisy or damaged, replace propeller shaft assembly.

VIBRATION

If vibration is present at high speed, inspect propeller shaft runout first.

1. With a dial indicator, measure propeller shaft runout at runout measuring points by rotating final drive companion flange with hands.

Propeller shaft runout : Refer to [DLN-89, "Propeller Shaft Runout"](#).

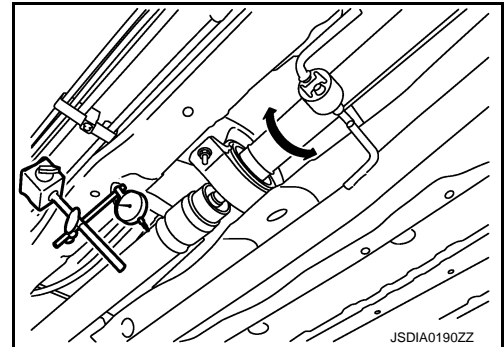

- Propeller shaft runout measuring point (Point "Δ").

↔ : Vehicle front

Dimension **A: 501 mm (19.72 in)**
 B: 445 mm (17.52 in)

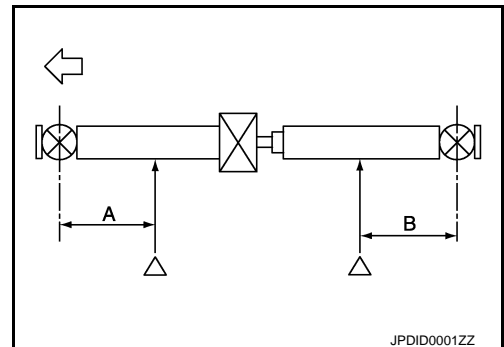

2. If runout still exceeds specifications, separate propeller shaft at final drive companion flange or transfer companion flange; then change the phase between companion flange and propeller shaft by the one bolt hole at a time and install propeller shaft.
3. Check runout again. If runout still exceeds specifications, replace propeller shaft assembly.
4. Check the vibration by driving vehicle.

REAR DIFFERENTIAL GEAR OIL

REAR DIFFERENTIAL GEAR OIL : Inspection

INFOID:000000007351432

OIL LEAKAGE

Make sure that oil is not leaking from final drive assembly or around it.

OIL LEVEL

- Remove filler plug (1) and check oil level from filler plug mounting hole as shown in the figure.

CAUTION:

Never start engine while checking oil level.

- Set a new gasket on filler plug and install it on final drive assembly. Refer to [DLN-106, "Exploded View"](#).

CAUTION:

Never reuse gasket.

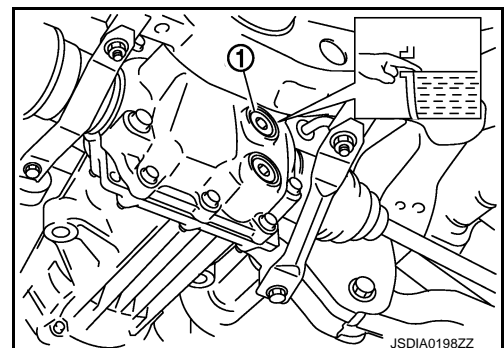

REAR DIFFERENTIAL GEAR OIL : Draining

INFOID:000000007351433

1. Stop engine.

A
B
C
D
E
F
G
H
I
J
K
L
M
N
O

MA

CHASSIS MAINTENANCE

< PERIODIC MAINTENANCE >

2. Remove drain plug (1) and drain gear oil.
3. Set a new gasket on drain plug and install it to final drive assembly and tighten to the specified torque. Refer to [DLN-106](#), "[Exploded View](#)".

CAUTION:

Never reuse gasket.

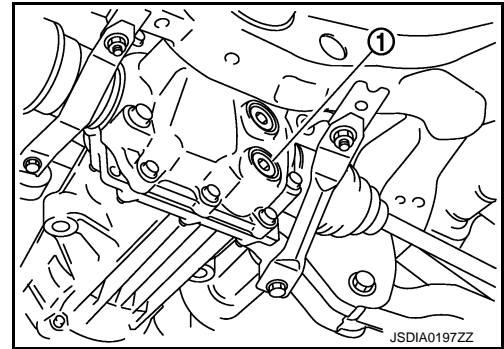

REAR DIFFERENTIAL GEAR OIL : Refilling

INFOID:000000007351434

1. Remove filler plug (1). Fill with new gear oil until oil level reaches the specified level near filler plug mounting hole.

Oil grade and viscosity

: Refer to [MA-15](#), "[FOR NORTH AMERICA : Fluids and Lubricants](#)" (for NORTH AMERICA), [MA-16](#), "[FOR MEXICO : Fluids and Lubricants](#)" (for MEXICO).

Oil capacity

: Refer to [DLN-128](#), "[General Specification](#)".

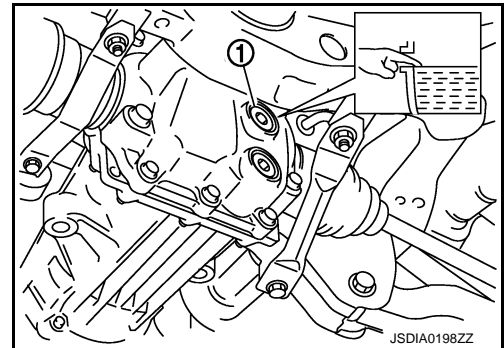

2. After refilling oil, check oil level. Set a new gasket to filler plug, then install it to final drive assembly. Refer to [DLN-106](#), "[Exploded View](#)".

CAUTION:

Never reuse gasket.

WHEELS

WHEELS : Adjustment

INFOID:00000000734082

BALANCING WHEELS (ALUMINUM WHEEL)

Preparation Before Adjustment

Using releasing agent, remove double-faced adhesive tape from the road wheel.

CAUTION:

- **Be careful not scratch the road wheel during removal.**
- **After removing double-faced adhesive tape, wipe clean traces of releasing agent from the road wheel.**

Wheel Balance Adjustment

- The details of the adjustment procedure are different for each model of wheel balancer. Therefore, refer to each instruction manual.
- If a tire balance machine has adhesion balance weight mode settings and drive-in weight mode setting, select and adjust a drive-in weight mode suitable for road wheels.

1. Set road wheel on tire balance machine using the center hole as a guide. Start the tire balance machine.
2. When inner and outer unbalance values are shown on the tire balance machine indicator, multiply outer unbalance value by 5/3 to determine balance weight that should be used. Select the outer balance weight with a value closest to the calculated value above and install in to the designated outer position of, or at the designated angle in relation to the road wheel.

CAUTION:

- **Never install the inner balance weight before installing the outer balance weight.**
- **Before installing the balance weight, be sure to clean the mating surface of the road wheel.**

CHASSIS MAINTENANCE

< PERIODIC MAINTENANCE >

- a. Indicated unbalance value $\times 5/3 =$ balance weight to be installed

Calculation example:

23 g (0.81 oz) $\times 5/3 = 38.33$ g (1.35 oz) \Rightarrow 40 g (1.41 oz) balance weight (closer to calculated balance weight value)

NOTE:

Note that balance weight value must be closer to the calculated balance weight value.

Example:

37.4 \Rightarrow 35 g (1.23 oz)

37.5 \Rightarrow 40 g (1.41 oz)

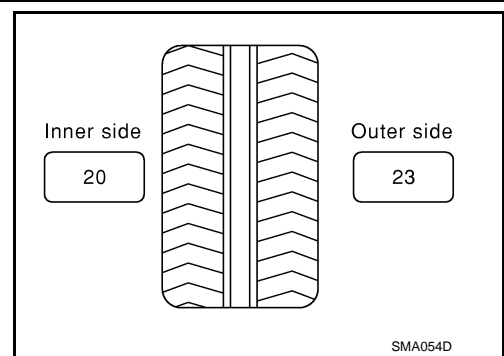

- b. Installed balance weight in the position.

- When installing balance weight (1) to road wheels, set it into the grooved area (A) on the inner wall of the road wheel as shown in the figure so that the balance weight center (B) is aligned with the tire balance machine indication position (angle) (C).

CAUTION:

- Always use genuine NISSAN adhesion balance weights.
- Balance weights are non-reusable; always replace with new ones.
- Never install three or more sheets of balance weight.

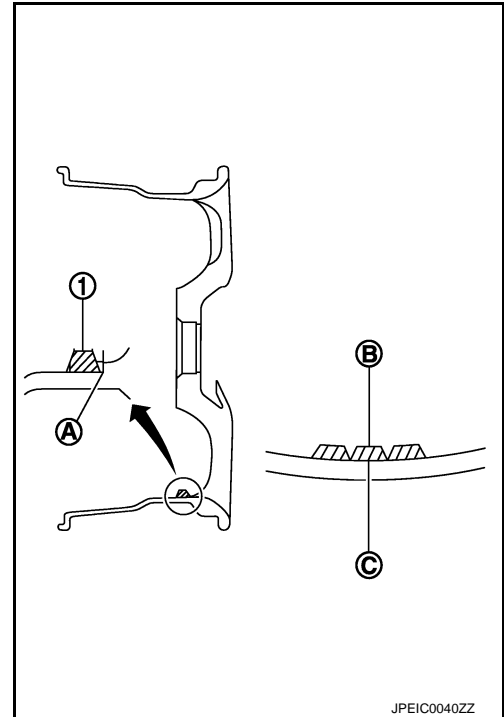

- c. If calculated balance weight value exceeds 50 g (1.76 oz), install two balance weight sheets in line with each other as shown in the figure.

CAUTION:

Never install one balance weight sheet on top of another.

- Start tire balance machine again.
- Install drive-in balance weight on inner side of road wheel in the tire balance machine indication position (angle).

CAUTION:

Never install three or more balance weight.

- Start the tire balance machine. Check that the inner and outer residual unbalance value is within the allowable unbalance value.

CAUTION:

If either residual unbalance value exceeds limit, repeat installation procedures.

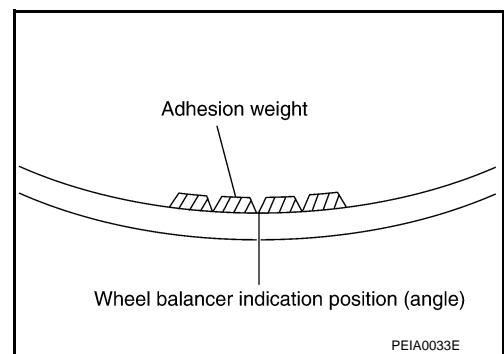

Allowable unbalance value

Dynamic (At flange) : Refer to [WT-49, "Road Wheel"](#).

Static (At flange) : Refer to [WT-49, "Road Wheel"](#).

BALANCING WHEELS (STEEL WHEEL)

A
B
C
D
E
F
G
H
I
J
K
L
M
N
O

MA

CHASSIS MAINTENANCE

< PERIODIC MAINTENANCE >

Preparation Before Adjustment

Remove balance weight from the road wheel.

CAUTION:

Be careful not to scratch the road wheel during removal.

Wheel Balance Adjustment

- The details of the adjustment procedure are different for each model of wheel balancer. Therefore, refer to each instruction manual.
- If a tire balance machine has adhesion balance weight mode settings and drive-in weight mode setting, select and adjust a drive-in weight mode suitable for steel wheels.

1. Set road wheel to wheel balancer, and then start wheel balancer.
2. Install balance weight to road wheel according to the unbalance and position (angle) displayed on wheel balancer.

CAUTION:

- Always use genuine NISSAN balance weights.
- Balance weights are non-reusable; always replace with new ones.
- Always use a plastic hammer when attaching the weight.
- Never install three or more balance weights on one side.

3. Start the tire balance machine. Check that the inner and outer residual unbalance value is within the allowable unbalance value.

CAUTION:

If either residual unbalance value exceeds limit, repeat installation procedures.

Allowable unbalance value

Dynamic (At flange) : Refer to [WT-49, "Road Wheel"](#).

Static (At flange) : Refer to [WT-49, "Road Wheel"](#).

TIRE ROTATION

- Follow the maintenance schedule for tire rotation service intervals. Refer to [MA-9, "FOR NORTH AMERICA : Schedule 1"](#).

- When installing the wheel, tighten wheel nuts to the specified torque. Refer to [WT-44, "Exploded View"](#).

CAUTION:

- Do not include the T-type spare tire when rotating the tires.
 - When installing wheels, tighten them diagonally by dividing the work two to three times in order to prevent the wheels from developing any distortion.
 - Be careful not to tighten wheel nut at torque exceeding the criteria for preventing strain of disc rotor.
 - Use NISSAN genuine wheel nuts for aluminum wheels.
- Perform the ID registration, after tire rotation. Refer to [WT-7, "Work Procedure"](#).

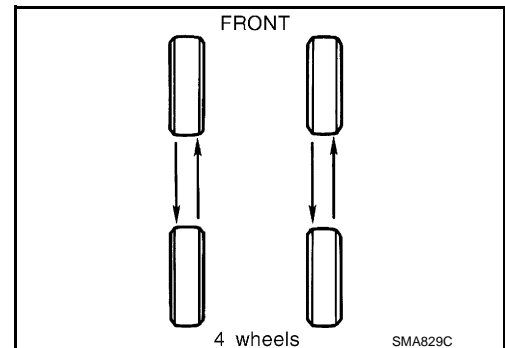

BRAKE FLUID LEVEL AND LEAKS

BRAKE FLUID LEVEL AND LEAKS : Inspection

INFOID:000000007351436

- If fluid level is extremely low, check brake system for leaks.

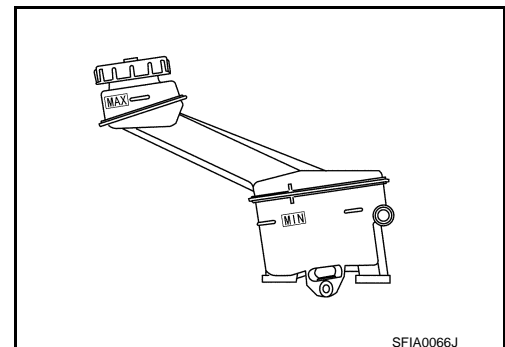

BRAKE LINES AND CABLES

CHASSIS MAINTENANCE

< PERIODIC MAINTENANCE >

BRAKE LINES AND CABLES : Inspection

INFOID:000000007351437

- Check brake fluid lines and parking brake cables for improper attachment, leaks, chafing, abrasions, deterioration, etc.

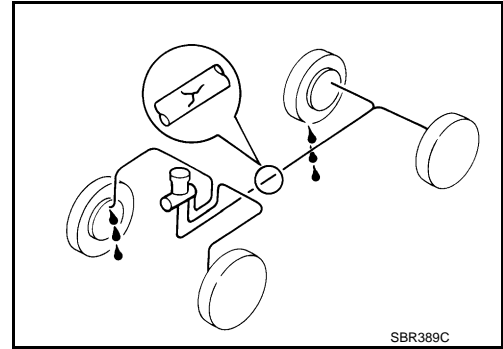

BRAKE FLUID

BRAKE FLUID : Changing

INFOID:000000007351438

1. Drain brake fluid from each bleed valve.
2. Refill until new brake fluid comes out from each bleed valve. Use same procedure as in bleeding hydraulic system to refill brake fluid.
Refer to [BR-11. "Refilling"](#).
 - Refill with recommended brake fluid.
Refer to [MA-15. "FOR NORTH AMERICA : Fluids and Lubricants"](#) (FOR NORTH AMERICA), [MA-16. "FOR MEXICO : Fluids and Lubricants"](#) (FOR MEXICO).
 - Never reuse drained brake fluid.
 - Be careful not to splash brake fluid on painted areas.

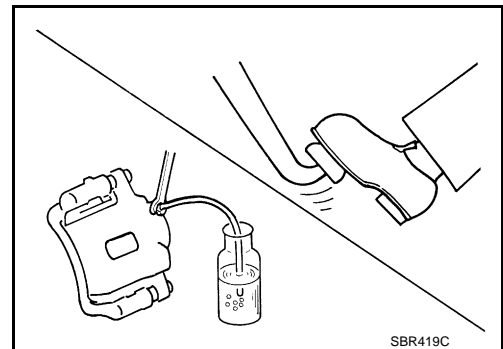

DISC BRAKE

DISC BRAKE : Inspection

INFOID:000000007351439

DISC ROTOR

Check condition, wear, and damage.

CALIPER

- Check for leakage.

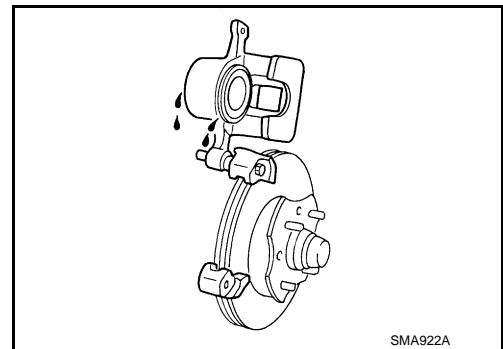

BRAKE PAD

A
B
C
D
E
F
G
H
I
J
K
L
M
N
O

MA

CHASSIS MAINTENANCE

< PERIODIC MAINTENANCE >

- Check for wear or damage.

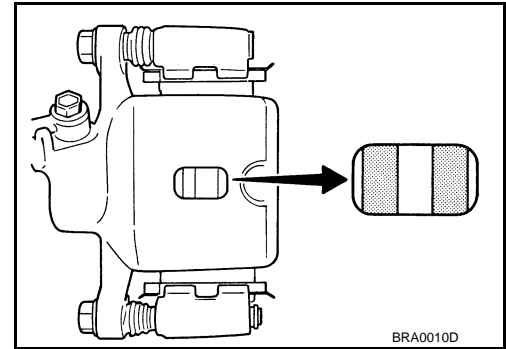

DISC BRAKE : Front Disc Brake

INFOID:000000007351440

Unit: mm (in)

Brake pad	Standard thickness	11.0 (0.433)
	Wear limit thickness	2.0 (0.079)
Disc rotor	Standard thickness	26.0 (1.024)
	Wear limit thickness	24.0 (0.945)
	Thickness variation (measured at 8 positions)	0.020 (0.0008)
	Runout limit (with it attached to the vehicle)	0.035 (0.0014)

DISC BRAKE : Rear Disc Brake

INFOID:000000007351441

Unit: mm (in)

Brake pad	Standard thickness	8.5 (0.335)
	Wear limit thickness	1.5 (0.059)
Disc rotor	Standard thickness	16.0 (0.630)
	Wear limit thickness	14.0 (0.551)
	Thickness variation (measured at 8 positions)	0.020 (0.0008)
	Runout limit (with it attached to the vehicle)	0.070 (0.0028)

STEERING GEAR AND LINKAGE

STEERING GEAR AND LINKAGE : Inspection

INFOID:000000007351442

STEERING GEAR

- Check gear housing and boots for looseness, damage and grease leakage.
- Check connection with steering column for looseness.

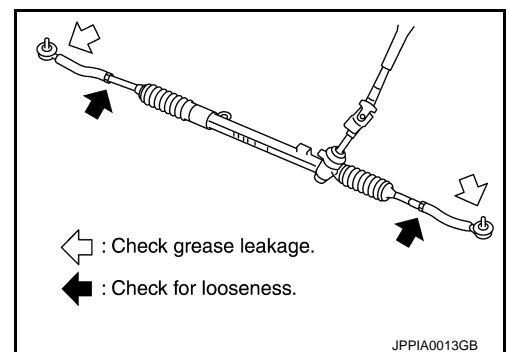

STEERING LINKAGE

Check ball joint, dust cover and other component parts for looseness, wear, damage and grease leakage.

AXLE AND SUSPENSION PARTS

CHASSIS MAINTENANCE

< PERIODIC MAINTENANCE >

AXLE AND SUSPENSION PARTS : Inspection

INFOID:000000007351443

Check front and rear axle and suspension parts for excessive play, cracks, wear or other damage.

- Shake each wheel to check for excessive play.
- Check wheel bearings for smooth operation.
- Check axle and suspension nuts and bolts for looseness.
- Check strut (shock absorber) for oil leakage or other damage.
- Check suspension ball joint for grease leakage and ball joint dust cover for cracks or other damage.

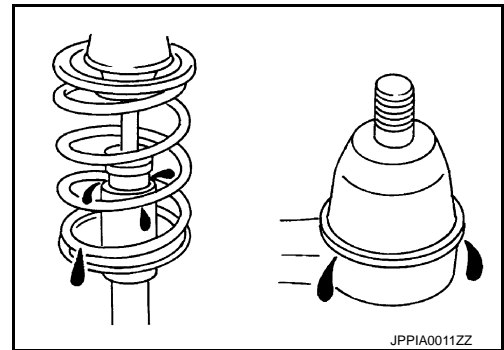
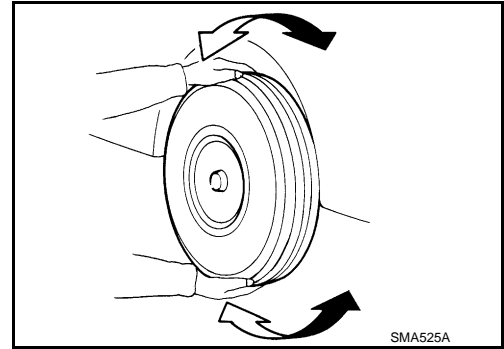

DRIVE SHAFT

DRIVE SHAFT : Inspection

INFOID:000000007351444

- Check boot and drive shaft for cracks, wear, damage and grease leakage.

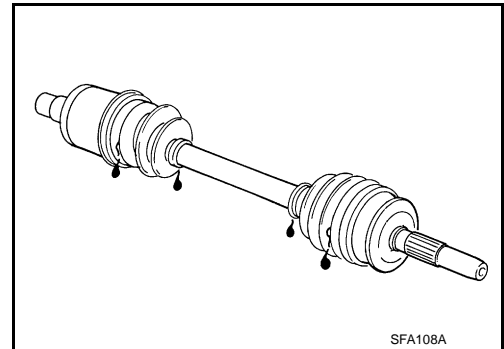

A
B
C
D
E
F
G
H
I
J
K
L
M
N
O

MA

BODY MAINTENANCE

< PERIODIC MAINTENANCE >

BODY MAINTENANCE

LOCKS, HINGES AND HOOD LATCH

LOCKS, HINGES AND HOOD LATCH : Lubricating

INFOID:000000007351445

WITH INTELLIGENT KEY SYSTEM

For hood and hood lock illustration.

- Hood: Refer to [DLK-200, "HOOD ASSEMBLY : Exploded View"](#).
- Hood lock control: Refer to [DLK-205, "HOOD LOCK CONTROL : Exploded View"](#).

For front door and front door lock illustration.

- Front door: Refer to [DLK-211, "DOOR ASSEMBLY : Exploded View"](#).
- Front door lock: Refer to [DLK-229, "DOOR LOCK : Exploded View"](#).
- Rear door: Refer to [DLK-216, "DOOR ASSEMBLY : Exploded View"](#).
- Rear door lock: Refer to [DLK-236, "DOOR LOCK : Exploded View"](#).

For back door and back door lock illustration.

- Back door: Refer to [DLK-221, "BACK DOOR ASSEMBLY : Exploded View"](#).
- Back door lock: Refer to [DLK-241, "DOOR LOCK : Exploded View"](#).

WITHOUT INTELLIGENT KEY SYSTEM

For hood and hood lock illustration.

- Hood: Refer to [DLK-367, "HOOD ASSEMBLY : Exploded View"](#).
- Hood lock control: Refer to [DLK-372, "HOOD LOCK CONTROL : Exploded View"](#).

For front door and front door lock illustration.

- Front door: Refer to [DLK-378, "DOOR ASSEMBLY : Exploded View"](#).
- Front door lock: Refer to [DLK-396, "DOOR LOCK : Exploded View"](#).
- Rear door: Refer to [DLK-383, "DOOR ASSEMBLY : Exploded View"](#).
- Rear door lock: Refer to [DLK-403, "DOOR LOCK : Exploded View"](#).

For back door and back door lock illustration.

- Back door: Refer to [DLK-388, "BACK DOOR ASSEMBLY : Exploded View"](#).
- Back door lock: Refer to [DLK-408, "DOOR LOCK : Exploded View"](#).

SEAT BELT, BUCKLES, RETRACTORS, ANCHORS AND ADJUSTERS

SEAT BELT, BUCKLES, RETRACTORS, ANCHORS AND ADJUSTERS : Inspection

INFOID:000000007351446

For front seat belt illustration. Refer to [SB-7, "SEAT BELT RETRACTOR : Exploded View"](#).

For rear seat belt illustration. Refer to [SB-12, "SEAT BELT RETRACTOR : Exploded View"](#).

CAUTION:

- **After any collision, inspect all seat belt assemblies, including retractors and other attached hardwares (i.e. anchor bolt, guide rail set). Nissan recommends to replace all seat belt assemblies in use during a collision, unless not damaged and properly operating after minor collision. Also inspect seat belt assemblies not in use during a collision, and replace if damaged or improperly operating.**
- **Seat belt pre-tensioner should be replaced even if the seat belts are not in use during a frontal collision where the driver and passenger air bags are deployed.**
- **If any component of seat belt assembly is questionable, do not repair. Replace as seat belt assembly.**
- **If webbing is cut, frayed, or damaged, replace belt assembly.**
- **Never oil tongue and buckle.**
- **Use a genuine NISSAN seat belt assembly.**

For details, refer to [SB-5, "SEAT BELT RETRACTOR : Inspection"](#) , [SB-10, "SEAT BELT RETRACTOR : Inspection"](#) in SB section.

- Check anchors for loose mounting
- Check belts for damage
- Check retractor for smooth operation
- Check function of buckles and tongues when buckled and released

SERVICE DATA AND SPECIFICATIONS (SDS)

< SERVICE DATA AND SPECIFICATIONS (SDS)

SERVICE DATA AND SPECIFICATIONS (SDS)

SERVICE DATA AND SPECIFICATIONS (SDS)

DRIVE BELTS

DRIVE BELTS : Drive belt

INFOID:000000007351447

DRIVE BELT

Tension of drive belt	Belt tension is not necessary, as it is automatically adjusted by drive belt auto-tensioner.
-----------------------	--

ENGINE COOLANT

ENGINE COOLANT : Periodical Maintenance Specification

INFOID:000000007351448

ENGINE COOLANT CAPACITY (APPROXIMATE)

Unit: ℓ (US qt, Imp qt)

Engine coolant capacity (With reservoir tank at "MAX" level)	7.3 (7-3/4, 6-3/8)
Reservoir tank	0.75 (5/8)

ENGINE OIL

ENGINE OIL : Periodical Maintenance Specification

INFOID:000000007351449

ENGINE OIL CAPACITY (APPROXIMATE)

Unit: ℓ (US qt, Imp qt)

Drain and refill	With oil filter change	4.8 (5-1/8, 4-1/4)
	Without oil filter change	4.5 (4-3/4, 4)
Dry engine (Overhaul)		5.4 (5-3/4, 4-3/4)

SPARK PLUG

SPARK PLUG : Spark Plug

INFOID:000000007351450

SPARK PLUG

Unit: mm (in)

Make	NGK
Standard type	DILKAR6A-11
Spark plug gap (Nominal)	1.1 (0.043)

ROAD WHEEL

ROAD WHEEL : Road Wheel

INFOID:000000007734083

ALUMINUM WHEEL

Item		Limit
Runout	Axial runout	Less than 0.3 mm (0.012 in)
	Radial runout	
Allowable unbalance	Dynamic (At flange)	Less than 5 g (0.17 oz) (one side)
	Static (At flange)	Less than 10 g (0.35 oz)

STEEL WHEEL

A
B
C
D
E
F
G
H
I
J
K
L
M
N
O

MA

SERVICE DATA AND SPECIFICATIONS (SDS)

< SERVICE DATA AND SPECIFICATIONS (SDS)

Item		Limit
Runout	Axial runout (Average)	Less than 0.8 mm (0.031 in)
	Radial runout (Average)	Less than 0.5 mm (0.020 in)
Allowable unbalance	Dynamic (At flange)	Less than 5 g (0.17 oz) (one side)
	Static (At flange)	Less than 10 g (0.35 oz)

STEEL WHEEL (EMERGENCY)

Item		Limit
Runout	Axial runout (Average)	Less than 1.2 mm (0.047 in)
	Radial runout (Average)	Less than 1.3 mm (0.051 in)