

SECTION **ACC**
ACCELERATOR CONTROL SYSTEM

A

ACC

C

D

E

CONTENTS

PRECAUTION	2	FOR MEXICO : Precaution for Supplemental Restraint System (SRS) "AIR BAG" and "SEAT BELT PRE-TENSIONER"	2	F
PRECAUTIONS	2			
FOR USA AND CANADA	2	REMOVAL AND INSTALLATION	4	G
FOR USA AND CANADA : Precaution for Supplemental Restraint System (SRS) "AIR BAG" and "SEAT BELT PRE-TENSIONER"	2	ACCELERATOR CONTROL SYSTEM	4	H
FOR MEXICO	2	Exploded View	4	
		Removal and Installation	4	
		Inspection	5	I

F

G

H

I

J

K

L

M

N

O

P

PRECAUTIONS

< PRECAUTION >

PRECAUTION

PRECAUTIONS

FOR USA AND CANADA

FOR USA AND CANADA : Precaution for Supplemental Restraint System (SRS) "AIR BAG" and "SEAT BELT PRE-TENSIONER"

INFOID:000000008279613

The Supplemental Restraint System such as "AIR BAG" and "SEAT BELT PRE-TENSIONER", used along with a front seat belt, helps to reduce the risk or severity of injury to the driver and front passenger for certain types of collision. This system includes seat belt switch inputs and dual stage front air bag modules. The SRS system uses the seat belt switches to determine the front air bag deployment, and may only deploy one front air bag, depending on the severity of a collision and whether the front occupants are belted or unbelted.

Information necessary to service the system safely is included in the "SRS AIR BAG" and "SEAT BELT" of this Service Manual.

WARNING:

Always observe the following items for preventing accidental activation.

- **To avoid rendering the SRS inoperative, which could increase the risk of personal injury or death in the event of a collision that would result in air bag inflation, all maintenance must be performed by an authorized NISSAN/INFINITI dealer.**
- **Improper maintenance, including incorrect removal and installation of the SRS, can lead to personal injury caused by unintentional activation of the system. For removal of Spiral Cable and Air Bag Module, see "SRS AIR BAG".**
- **Never use electrical test equipment on any circuit related to the SRS unless instructed to in this Service Manual. SRS wiring harnesses can be identified by yellow and/or orange harnesses or harness connectors.**

PRECAUTIONS WHEN USING POWER TOOLS (AIR OR ELECTRIC) AND HAMMERS

WARNING:

Always observe the following items for preventing accidental activation.

- **When working near the Air Bag Diagnosis Sensor Unit or other Air Bag System sensors with the ignition ON or engine running, never use air or electric power tools or strike near the sensor(s) with a hammer. Heavy vibration could activate the sensor(s) and deploy the air bag(s), possibly causing serious injury.**
- **When using air or electric power tools or hammers, always switch the ignition OFF, disconnect the battery, and wait at least 3 minutes before performing any service.**

FOR MEXICO

FOR MEXICO : Precaution for Supplemental Restraint System (SRS) "AIR BAG" and "SEAT BELT PRE-TENSIONER"

INFOID:000000008279614

The Supplemental Restraint System such as "AIR BAG" and "SEAT BELT PRE-TENSIONER", used along with a front seat belt, helps to reduce the risk or severity of injury to the driver and front passenger for certain types of collision. Information necessary to service the system safely is included in the "SRS AIR BAG" and "SEAT BELT" of this Service Manual.

WARNING:

Always observe the following items for preventing accidental activation.

- **To avoid rendering the SRS inoperative, which could increase the risk of personal injury or death in the event of a collision that would result in air bag inflation, all maintenance must be performed by an authorized NISSAN/INFINITI dealer.**
- **Improper maintenance, including incorrect removal and installation of the SRS, can lead to personal injury caused by unintentional activation of the system. For removal of Spiral Cable and Air Bag Module, see "SRS AIR BAG".**
- **Never use electrical test equipment on any circuit related to the SRS unless instructed to in this Service Manual. SRS wiring harnesses can be identified by yellow and/or orange harnesses or harness connectors.**

PRECAUTIONS WHEN USING POWER TOOLS (AIR OR ELECTRIC) AND HAMMERS

WARNING:

PRECAUTIONS

< PRECAUTION >

Always observe the following items for preventing accidental activation.

- When working near the Air Bag Diagnosis Sensor Unit or other Air Bag System sensors with the ignition ON or engine running, never use air or electric power tools or strike near the sensor(s) with a hammer. Heavy vibration could activate the sensor(s) and deploy the air bag(s), possibly causing serious injury.
- When using air or electric power tools or hammers, always switch the ignition OFF, disconnect the battery, and wait at least 3 minutes before performing any service.

A

ACC

C

D

E

F

G

H

I

J

K

L

M

N

O

P

ACCELERATOR CONTROL SYSTEM

< REMOVAL AND INSTALLATION >

REMOVAL AND INSTALLATION

ACCELERATOR CONTROL SYSTEM

Exploded View

INFOID:000000008279615

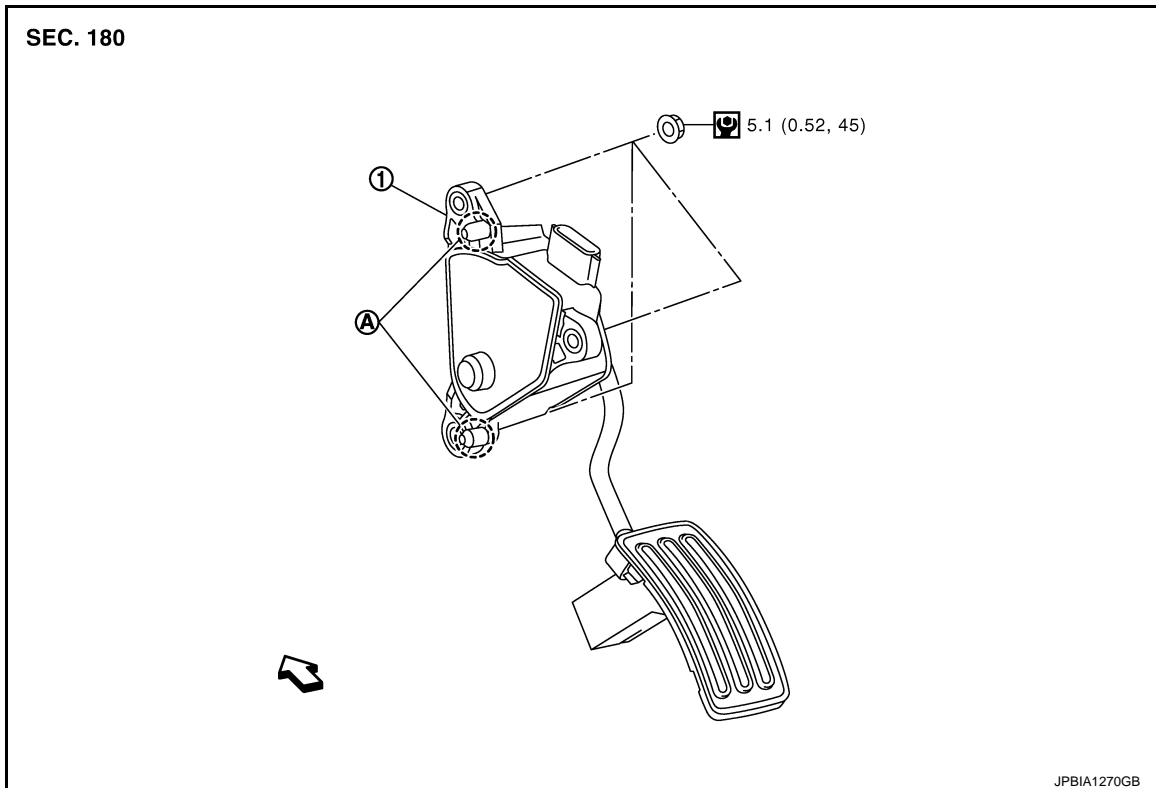

1. Accelerator pedal assembly

A. Locating pin

← : Vehicle front

⊗ : N·m (kg-m, in-lb)

Removal and Installation

INFOID:000000008279616

REMOVAL

1. Disconnect accelerator pedal position sensor harness connector.
2. Remove accelerator pedal assembly mounting nuts.
3. Loosen brake pedal assembly mounting nuts. Refer to [BR-19, "Exploded View"](#).

NOTE:

Brake pedal assembly does not have to be removed from the vehicle.

4. Remove accelerator pedal assembly.

CAUTION:

- Never disassemble accelerator lever. Never remove accelerator pedal position sensor from accelerator lever.
- Avoid impact from dropping etc. during handling.
- Be careful to keep accelerator lever away from water.

INSTALLATION

Note the following, and install in the reverse order of removal.

- Insert locating pin into vehicle side to position accelerator pedal assembly. Tighten mounting nuts to accelerator pedal assembly.

ACCELERATOR CONTROL SYSTEM

< REMOVAL AND INSTALLATION >

Inspection

INFOID:000000008279617

A

INSPECTION AFTER INSTALLATION

- Check that accelerator pedal moves smoothly within the whole operation range when it is depressed fully and released.
- Check that accelerator pedal returns securely to the fully released position.
- For the electrical inspection of accelerator pedal position sensor. Refer to the following:
 - For Mexico: [EC-718, "Component Inspection"](#).
 - Except for Mexico: [EC-373, "Component Inspection"](#).
- **CAUTION:**
When harness connector of accelerator pedal position sensor is disconnected, perform "ACCELERATOR PEDAL RELEASED POSITION LEARNING". Refer to [EC-473, "ACCELERATOR PEDAL RELEASED POSITION LEARNING : Description"](#) (for Mexico) or [EC-22, "ACCELERATOR PEDAL RELEASED POSITION LEARNING : Description"](#) (Except for Mexico).

ACC

C

D

E

F

G

H

I

J

K

L

M

N

O

P