

SECTION **DLN**
DRIVELINE

A
B
C

DLN

CONTENTS

E

TRANSFER: TY30A

BASIC INSPECTION	4	C1210 ECM	19	F
DIAGNOSIS AND REPAIR WORK FLOW	4	Description	19	
Work Flow	4	DTC Logic	19	
SYSTEM DESCRIPTION	5	Diagnosis Procedure	19	G
AWD SYSTEM	5	C1211 AWD COMMUNICATION	20	
System Diagram	5	Description	20	H
System Description	7	DTC Logic	20	
Component Parts Location	9	Diagnosis Procedure	20	
Component Description	9	C1212 AWD COMMUNICATION	22	I
DIAGNOSIS SYSTEM (AWD CONTROL UNIT)	10	Description	22	
CONSULT Function	10	DTC Logic	22	
DTC/CIRCUIT DIAGNOSIS	12	Diagnosis Procedure	22	J
C1201 AWD CONTROL UNIT	12	U1000 CAN COMM CIRCUIT	24	
Description	12	Description	24	
DTC Logic	12	DTC Logic	24	K
Diagnosis Procedure	12	Diagnosis Procedure	24	
C1203 ABS ACTUATOR AND ELECTRIC UNIT (CONTROL UNIT)	13	U1010 CONTROL UNIT (CAN)	25	L
Description	13	Description	25	
DTC Logic	13	DTC Logic	25	
Diagnosis Procedure	13	Diagnosis Procedure	25	M
C1204 AWD SOLENOID	14	POWER SUPPLY AND GROUND CIRCUIT	26	
Description	14	Description	26	
DTC Logic	14	Diagnosis Procedure	26	N
Diagnosis Procedure	14	AWD LOCK SWITCH	28	
Component Inspection	16	Description	28	
C1205 AWD ACTUATOR RELAY	17	Diagnosis Procedure	28	O
Description	17	Component Inspection	29	
DTC Logic	17	AWD WARNING LAMP	30	P
Diagnosis Procedure	17	Description	30	
		Diagnosis Procedure	30	
		AWD LOCK INDICATOR LAMP	32	
		Description	32	
		Diagnosis Procedure	32	

ECU DIAGNOSIS INFORMATION	33	PREPARATION	51
AWD CONTROL UNIT	33	PREPARATION	51
Reference Value (Without VDC)	33	Special Service Tools	51
Reference Value (With VDC)	35	PERIODIC MAINTENANCE	54
Wiring Diagram - AWD SYSTEM -	36	TRANSFER OIL	54
Fail Safe	37	Inspection	54
DTC Inspection Priority Chart	38	Draining	54
DTC Index	39	Refilling	54
SYMPTOM DIAGNOSIS	40	REMOVAL AND INSTALLATION	55
AWD WARNING LAMP DOES NOT TURN ON		AWD CONTROL UNIT	55
.....	40	Exploded View	55
Description	40	Removal and Installation	55
Diagnosis Procedure	40	UNIT REMOVAL AND INSTALLATION	56
AWD WARNING LAMP DOES NOT TURN OFF	41	TRANSFER ASSEMBLY	56
Description	41	Exploded View	56
Diagnosis Procedure	41	Removal and Installation	56
HEAVY TIGHT-CORNER BRAKING SYMPTOM OCCURS	42	UNIT DISASSEMBLY AND ASSEMBLY ...	58
Description	42	ADAPTER CASE	58
Diagnosis Procedure	42	Exploded View	58
VEHICLE DOES NOT ENTER AWD MODE	43	Disassembly	59
Description	43	Assembly	59
Diagnosis Procedure	43	Inspection After Disassembly	60
AWD WARNING LAMP BLINKS QUICKLY	44	RING GEAR SHAFT	61
Description	44	Exploded View	61
AWD WARNING LAMP BLINKS SLOWLY	45	Disassembly	62
Description	45	Assembly	63
Diagnosis Procedure	45	Inspection After Disassembly	64
NORMAL OPERATING CONDITION	46	DRIVE PINION	65
Description	46	Exploded View	65
NOISE, VIBRATION AND HARSHNESS (NVH) TROUBLESHOOTING	47	Disassembly	66
NVH Troubleshooting Chart	47	Assembly	67
PRECAUTION	48	Adjustment	68
PRECAUTIONS	48	Inspection After Disassembly	77
FOR USA AND CANADA	48	TRANSFER CASE	78
FOR USA AND CANADA : Precaution for Supplemental Restraint System (SRS) "AIR BAG" and "SEAT BELT PRE-TENSIONER"	48	Exploded View	78
FOR USA AND CANADA : Service Notice or Precautions for Transfer	48	Disassembly	79
FOR MEXICO	49	Assembly	79
FOR MEXICO : Precaution for Supplemental Restraint System (SRS) "AIR BAG" and "SEAT BELT PRE-TENSIONER"	49	Inspection	80
FOR MEXICO : Service Notice or Precautions for Transfer	49	SERVICE DATA AND SPECIFICATIONS (SDS)	81
		SERVICE DATA AND SPECIFICATIONS (SDS)	81
		General Specifications	81
		Preload Torque	81
		Backlash	81
		Companion Flange Runout	81

REAR PROPELLER SHAFT: 3F SPL18-DOJ75	REAR DIFFERENTIAL GEAR OIL	96	
	Inspection	96	A
	Draining	96	
	Refilling	96	
SYMPTOM DIAGNOSIS	REMOVAL AND INSTALLATION	97	B
NOISE, VIBRATION AND HARSHNESS (NVH) TROUBLESHOOTING	FRONT OIL SEAL	97	
NVH Troubleshooting Chart	Exploded View	97	C
	Removal and Installation	97	
PREPARATION	SIDE OIL SEAL	99	
	Exploded View	99	
PREPARATION	Removal and Installation	99	DLN
Commercial Service Tool	ELECTRIC CONTROLLED COUPLING	100	
	Exploded View	100	E
PERIODIC MAINTENANCE	Removal and Installation	100	
REAR PROPELLER SHAFT	UNIT REMOVAL AND INSTALLATION ...	104	F
Inspection	REAR FINAL DRIVE ASSEMBLY	104	
REMOVAL AND INSTALLATION	Exploded View	104	G
REAR PROPELLER SHAFT	Removal and Installation	104	
Exploded View	UNIT DISASSEMBLY AND ASSEMBLY .	106	H
Removal and Installation	ELECTRIC CONTROLLED COUPLING	106	
Inspection	Exploded View	106	
SERVICE DATA AND SPECIFICATIONS (SDS)	Disassembly	107	I
SERVICE DATA AND SPECIFICATIONS (SDS)	Assembly	107	
General Specifications	Adjustment	109	J
Propeller Shaft Runout	Inspection After Disassembly	109	
Journal Axial Play	DIFFERENTIAL ASSEMBLY	111	
REAR FINAL DRIVE: R145	Exploded View	111	
SYSTEM DESCRIPTION	Disassembly	112	K
REAR FINAL DRIVE ASSEMBLY	Assembly	113	
System Diagram	Inspection After Disassembly	116	L
SYMPTOM DIAGNOSIS	DRIVE PINION	118	
NOISE, VIBRATION AND HARSHNESS (NVH) TROUBLESHOOTING	Exploded View	118	
NVH Troubleshooting Chart	Disassembly	119	M
PRECAUTION	Assembly	120	
PRECAUTIONS	Adjustment	123	
Service Notice or Precautions for Rear Final Drive...	Inspection After Disassembly	126	N
	SERVICE DATA AND SPECIFICATIONS (SDS)	128	
PREPARATION	SERVICE DATA AND SPECIFICATIONS (SDS)	128	O
	General Specification	128	
PREPARATION	Drive Gear Runout	128	P
Special Service Tools	Differential Side Gear Clearance	128	
Commercial Service Tools	Preload Torque	128	
PERIODIC MAINTENANCE	Backlash	128	
	Companion Flange Runout	128	

BASIC INSPECTION

DIAGNOSIS AND REPAIR WORK FLOW

Work Flow

INFOID:000000008280048

DETAILED FLOW

1. INTERVIEW FROM THE CUSTOMER

Clarify customer complaints before inspection. First of all, reproduce symptoms, and understand them fully. Ask customer about his/her complaints carefully. Check symptoms by driving vehicle with customer, if necessary.

CAUTION:

Customers are not professional. Never guess easily like “maybe the customer means that...,” or “maybe the customer mentions this symptom”.

>> GO TO 2.

2. CHECK AWD WARNING LAMP

Start engine and drive at 30 km/h (19 MPH) or more for approx. 1 minute.

Does AWD warning lamp turn ON?

- YES >> GO TO 3.
- NO >> GO TO 6.

3. PERFORM SELF-DIAGNOSIS

Ⓟ With CONSULT

1. Perform self-diagnosis for “ALL MODE AWD/4WD”.
2. Check malfunction detected by self-diagnosis.
3. Erase self-diagnostic results for “ALL MODE AWD/4WD”.

>> GO TO 4.

4. CHECK TERMINALS AND HARNESS CONNECTORS

Check pin terminals for damage or loose connection with harness connector.

>> GO TO 5.

5. CHECK SYMPTOM REPRODUCTION

Ⓟ With CONSULT

Perform DTC reproduction procedure for the error system.

Is any error detected?

- YES >> GO TO 2.
- NO >> GO TO 6.

6. PERFORM SYMPTOM DIAGNOSIS

Perform the symptom diagnosis for each system.

Is any malfunction present?

- YES >> GO TO 2.
- NO >> GO TO 7.

7. FINAL CHECK

Ⓟ With CONSULT

Check input/output signal standard for “ALL MODE AWD/4WD”.

Is the input/output the standard value?

- YES >> INSPECTION END
- NO >> GO TO 2.

AWD SYSTEM

< SYSTEM DESCRIPTION >

[TRANSFER: TY30A]

SYSTEM DESCRIPTION

AWD SYSTEM

System Diagram

INFOID:000000008280049

CONTROL DIAGRAM (WITHOUT VDC)

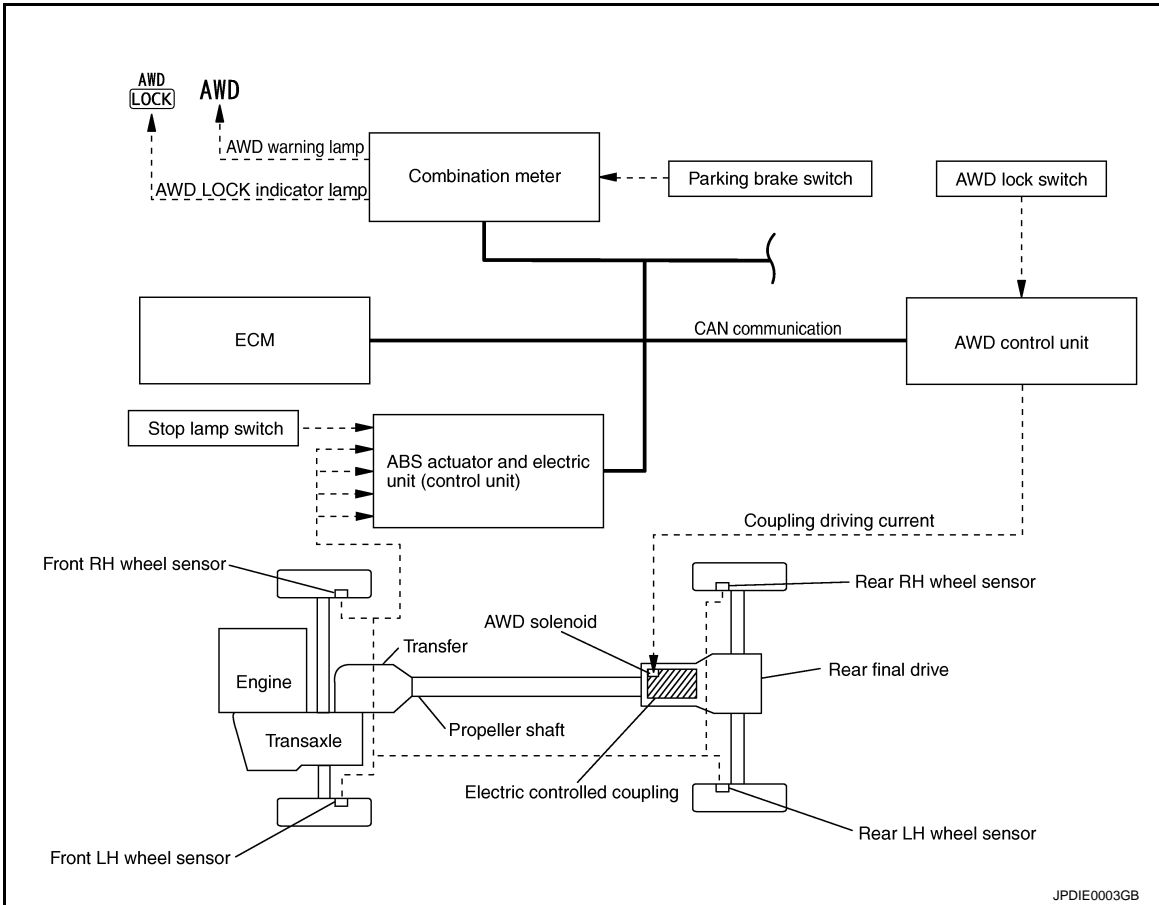

CONTROL DIAGRAM (WITH VDC)

A
B
C
DLN
E
F
G
H
I
J
K
L
M
N
O
P

AWD SYSTEM

< SYSTEM DESCRIPTION >

[TRANSFER: TY30A]

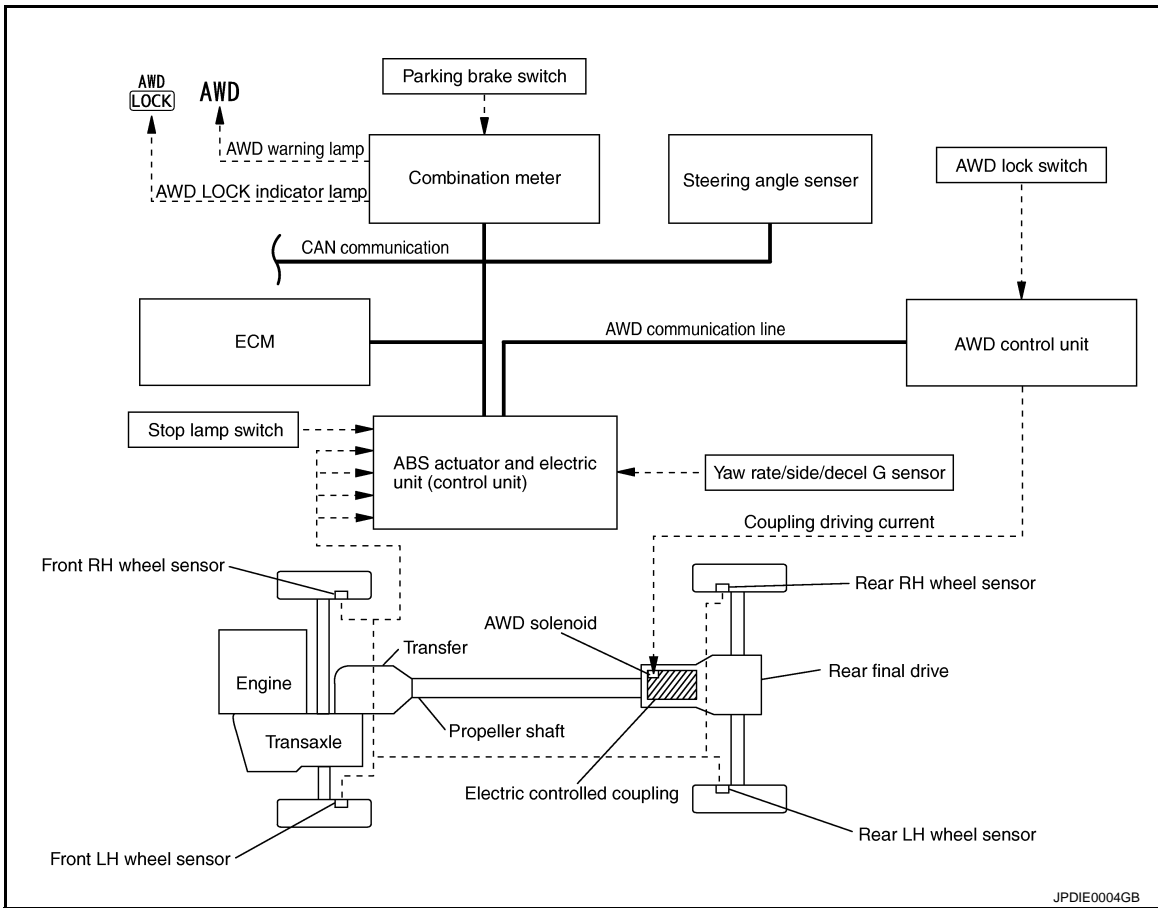

JPDIE0004GB

CROSS-SECTIONAL VIEW

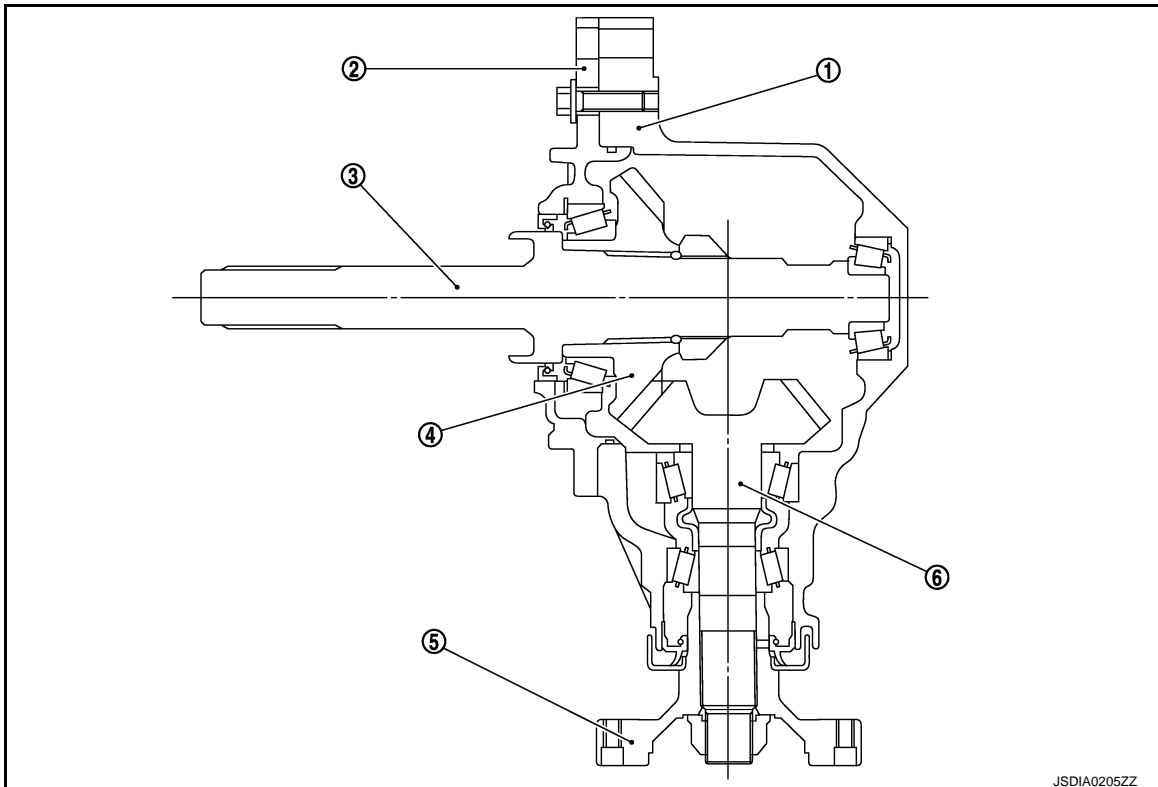

JSDIA0205ZZ

AWD SYSTEM

< SYSTEM DESCRIPTION >

[TRANSFER: TY30A]

- | | | |
|------------------|---------------------|--------------------|
| 1. Transfer case | 2. Adapter case | 3. Ring gear shaft |
| 4. Ring gear | 5. Companion flange | 6. Drive pinion |

A

System Description

INFOID:000000008280050

B

DESCRIPTION

- AWD controls distribution of drive power between front-wheel drive (100:0) and 4-wheel drive (50:50) conditions according to signals from sensors.
- By receiving the steering angle sensor signal and G sensor signal, vehicle with VDC corrects a torque distribution for front and rear wheels according to a driving operation and a behavior of the vehicle during cornering and improves driveability and safety on a slippery road surface.
- It transmits/receives each signal from the following AWD control unit via CAN communication line (without VDC).

C

DLN

Component parts	Function
ABS actuator and electric unit (control unit)	Transmits the following signals via CAN communication to AWD control unit. <ul style="list-style-type: none"> • Vehicle speed signal • Stop lamp switch signal (brake signal)
ECM	Transmits the following signals via CAN communication to AWD control unit. <ul style="list-style-type: none"> • Accelerator pedal position signal • Engine speed signal
Combination meter	Transmits conditions of parking brake switch signal via CAN communication for AWD control unit.
	Receives the following signals via CAN communication to AWD control unit. <ul style="list-style-type: none"> • AWD warning lamp signal • Mode lamp signal

E

F

G

H

- It transmits/receives each signal from the following ABS actuator and electric unit (control unit) control unit via CAN communication line (with VDC).

I

Component parts	Function
ECM	Transmits the following signals via CAN communication to ABS actuator and electric unit (control unit). <ul style="list-style-type: none"> • Accelerator pedal position signal • Engine speed signal
Combination meter	Transmits conditions of parking brake switch signal via CAN communication for ABS actuator and electric unit (control unit).
	Receives the following signals via CAN communication to ABS actuator and electric unit (control unit). <ul style="list-style-type: none"> • AWD warning lamp signal • Mode lamp signal

J

K

L

M

- It transmits/receives each signal from the following AWD control unit via AWD communication line (with VDC).

N

Component parts	Function
ABS actuator and electric unit (control unit)	Transmits conditions of AWD solenoid signal via AWD communication for AWD control unit.
	Receives the following signals via AWD communication from AWD control unit. <ul style="list-style-type: none"> • AWD lock switch signal • AWD solenoid monitor signal

O

P

AUTO Mode

- Electronic control allows optimal distribution of torque to front/rear wheels to match road conditions.
- AWD mode makes possible stable driving possible with no wheel spin, on snowy roads or other slippery surfaces.
- On roads which do not require 4-wheel drive, AUTO mode contributes to improved fuel economy by driving in conditions close to front-wheel drive.

AWD SYSTEM

[TRANSFER: TY30A]

< SYSTEM DESCRIPTION >

- Sensor inputs determine the vehicle's turning condition, and tight cornering/braking are controlled by distributing optimum torque to rear wheels.

LOCK Mode

- Front/rear wheel torque distribution is fixed, ensuring stable driving when climbing slopes.
- Vehicle will switch automatically to AUTO mode if vehicle speed increases. Vehicle automatically returns to direct 4-wheel driving conditions if vehicle speed decreases.

NOTE:

If there is a significant difference in pressure or wear between tires, full vehicle performance is not available. LOCK mode may be prohibited, or speeds at which LOCK mode is enabled may be restricted according to the tire conditions.

CAUTION:

Never switch to LOCK when rotation speed of front and rear wheel differs.

POWER TRANSFER DIAGRAM

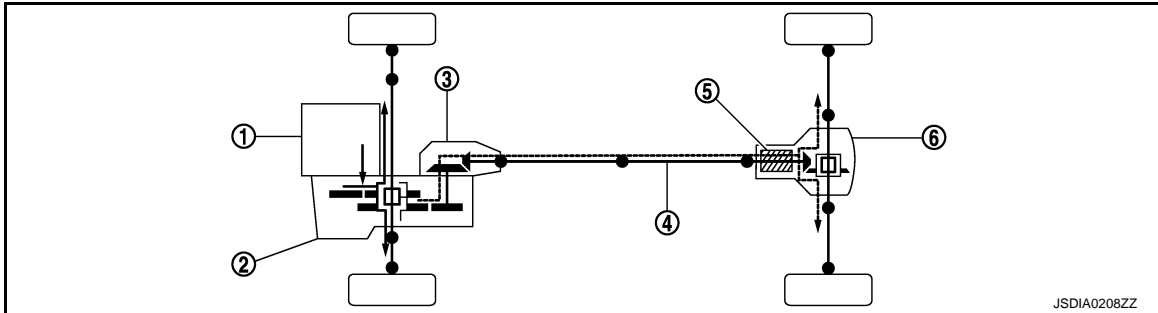

- | | | |
|--------------------|---------------------------------|---------------------|
| 1. Engine | 2. Transaxle | 3. Transfer |
| 4. Propeller shaft | 5. Electric controlled coupling | 6. Rear final drive |

OPERATION PRINCIPLE

Electric Controlled Coupling

1. The AWD control unit supplies command current to electric controlled coupling (AWD solenoid).
2. The control clutch is engaged by electromagnet and torque is detected in control clutch.
3. The cam operates in response to control clutch torque and applies pressure to main clutch.
4. The main clutch transmits torque to front wheels according to pressing power.

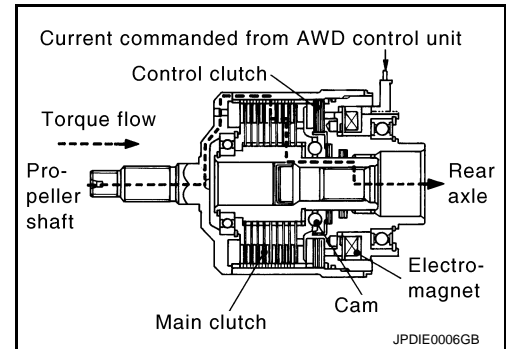

- Transmission torque to the rear wheels is determined according to command current.

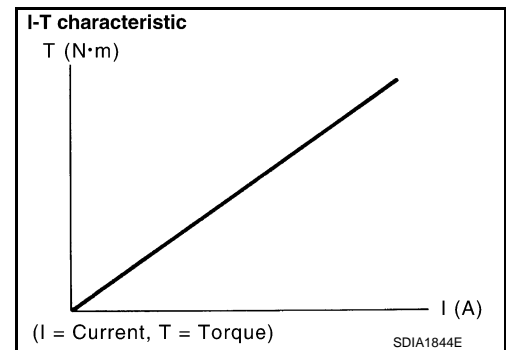

AWD SYSTEM

< SYSTEM DESCRIPTION >

[TRANSFER: TY30A]

Component Parts Location

INFOID:000000008280051

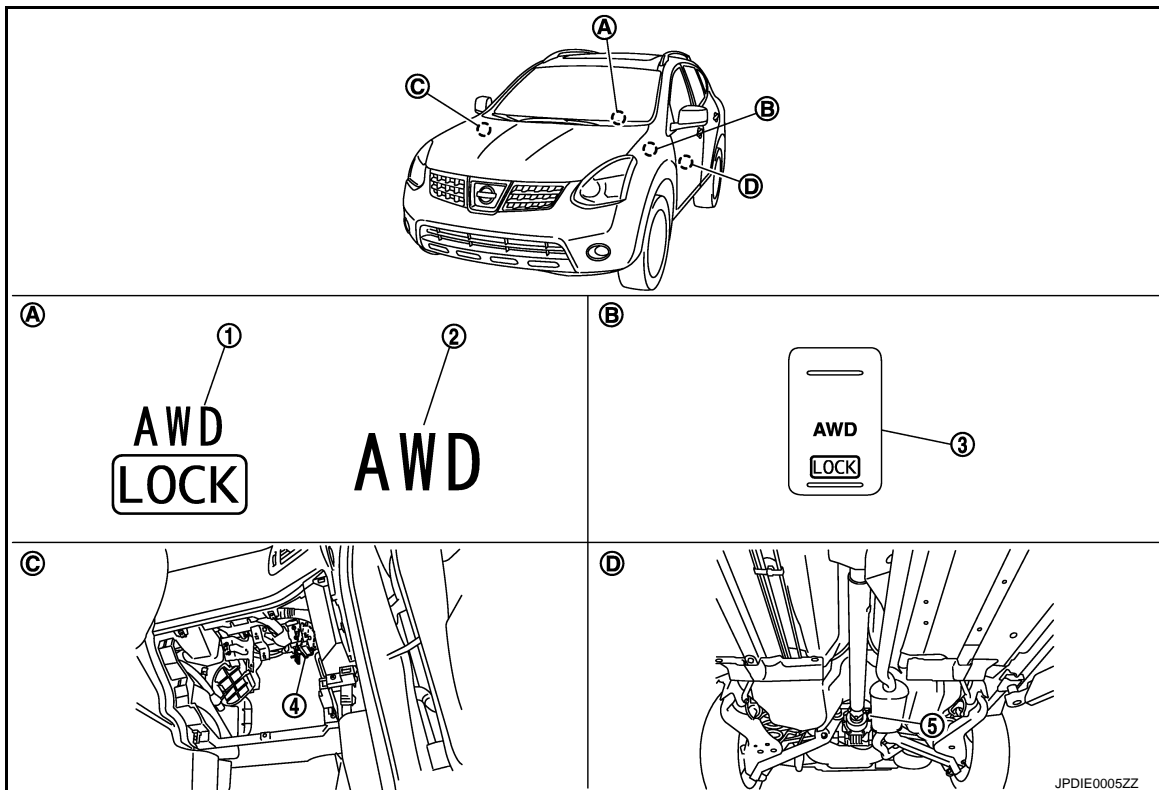

- 1. AWD LOCK indicator lamp
- 2. AWD warning lamp
- 3. AWD lock switch
- 4. AWD control unit
- 5. AWD solenoid (in rear final drive)
- A. Combination meter
- B. Instrument panel
- C. Glove box cover assembly removed
- D. Rear final drive assembly

Component Description

INFOID:000000008280052

Component parts	Reference/Function
AWD control unit	DLN-12. "Description"
Wheel sensors	BRC-18. "Description"
AWD solenoid	DLN-14. "Description"
Electric controlled coupling	Transmits driving force to rear final drive.
AWD warning lamp	DLN-30. "Description"
AWD LOCK indicator lamp	DLN-32. "Description"
AWD lock switch	DLN-28. "Description"
ABS actuator and electric unit (control unit)	DLN-13. "Description"
ECM	DLN-19. "Description"
Combination meter	DLN-30. "Description"
Steering angle sensor*	BRC-134. "Description"
Yaw rate/side/decel G sensor*	BRC-112. "Description"

*: With VDC

DIAGNOSIS SYSTEM (AWD CONTROL UNIT)

< SYSTEM DESCRIPTION >

[TRANSFER: TY30A]

DIAGNOSIS SYSTEM (AWD CONTROL UNIT)

CONSULT Function

INFOID:000000008280053

FUNCTION

CONSULT can display each diagnostic item using the diagnostic test modes as follows.

Diagnostic test mode	Function
ECU Identification	AWD control unit part number can be read.
Self Diagnostic Result	Self-diagnostic results can be read and erased quickly.
Data Monitor	Input/Output data in the AWD control unit can be read.
Active Test	Diagnostic Test Mode in which CONSULT drives some actuators apart from the AWD control unit and also shifts some parameters in a specified range.

SELF DIAGNOSTIC RESULT

Drive at 30 km/h (19 MPH) or more for approximately 1 minute before performing the self-diagnosis.

Display Item List

Refer to [DLN-39, "DTC Index"](#).

How to Erase Self-Diagnostic Results

Before erasing DTC memory, start the engine and drive at 30 km/h (19 MPH) or more for approximately 1 minute. Check that ABS warning lamp turns OFF.

NOTE:

When 4WD warning lamp is ON with system malfunction of DTC "C1203", run the vehicle at 30 km/h (19MPH) or more for a minute and check that ABS warning lamp is turned OFF. Then turn ignition switch OFF, and start the engine again. Otherwise 4WD warning lamp may not turn OFF even if it is normal.

DATA MONITOR

Display Item List

NOTE:

The following table includes information (items) inapplicable to this vehicle. For information (items) applicable to this vehicle, refer to CONSULT display items.

×: Applicable ▼: Optional item

Monitor item (Unit)	Monitor Menu		Remarks
	ECU INPUT SIGNALS	MAIN SIGNALS	
FR RH SENSOR [km/h] or [mph]	×	×	Wheel speed calculated by front RH wheel sensor signal is displayed.
FR LH SENSOR [km/h] or [mph]	×	×	Wheel speed calculated by front LH wheel sensor signal is displayed.
RR RH SENSOR [km/h] or [mph]	×	×	Wheel speed calculated by rear RH wheel sensor signal is displayed.
RR LH SENSOR [km/h] or [mph]	×	×	Wheel speed calculated by rear LH wheel sensor signal is displayed.
BATTERY VOLT [V]	▼	▼	Power supply voltage for AWD control unit
THRTL POS SEN [%]	▼	▼	Throttle opening status is displayed.
ETS SOLENOID [A]	▼	▼	Monitored value of current at AWD solenoid
STOP LAMP SW [On/Off]	▼	▼	Stop lamp switch signal status via CAN communication line is displayed.
ENG SPEED SIG [Run/Stop]	▼	▼	Engine status is displayed.
ETS ACTUATOR [On/Off]	▼	▼	Operating condition of AWD actuator relay (integrated in AWD control unit) is displayed.
4WD WARN LAMP [On/Off]	▼	▼	Control status of AWD warning lamp is displayed.

DIAGNOSIS SYSTEM (AWD CONTROL UNIT)

< SYSTEM DESCRIPTION >

[TRANSFER: TY30A]

Monitor item (Unit)	Monitor Menu		Remarks
	ECU INPUT SIGNALS	MAIN SIGNALS	
4WD MODE SW [AUTO/LOCK]	▼	▼	AWD lock switch status is displayed.
4WD MODE MON [AUTO/LOCK]	▼	▼	Control status of AWD is displayed.
DIS-TIRE MONI [mm]	▼	▼	Improper size tire installed condition is displayed.
P BRAKE SW [On/Off]	▼	▼	Parking switch signal status via CAN communication line is displayed.

ACTIVE TEST

Description

Use this mode to determine and identify the details of a malfunction based on self-diagnostic results or data monitor. AWD control unit gives drive signal to actuator with receiving command from CONSULT to check operation of actuator.

Test Item

Test item	Condition	Description
ETS S/V (Detects AWD solenoid)	<ul style="list-style-type: none"> Vehicle stopped Engine running No DTC detected 	Change command current value to AWD solenoid, and then change driving mode. (Monitor value is normal if it is within approximately $\pm 10\%$ of command value.) <ul style="list-style-type: none"> Qu: Increase current value in increments of 0.2 A Qd: Decrease current value in increments of 0.2 A UP: Increase current value in increments of 0.02 A DOWN: Decrease current value in increments of 0.02 A

CAUTION:

Never energize continuously for a long time.

A
B
C
DLN
E
F
G
H
I
J
K
L
M
N
O
P

DTC/CIRCUIT DIAGNOSIS

C1201 AWD CONTROL UNIT

Description

INFOID:000000008280054

- Controls driving force distribution by signals from each sensor from front wheel driving mode (100:0) to 4-wheel driving mode (50:50) (without VDC).
- Controls driving force distribution by signals from ABS actuator and electric unit (control unit) from front-wheel driving mode (100:0) to 4-wheel driving mode (50:50) (with VDC).
- Front wheel driving conditions is available by fail-safe function if malfunction is detected in AWD system.

DTC Logic

INFOID:000000008280055

DTC DETECTION LOGIC

DTC	Items (CONSULT screen terms)	Diagnostic item is detected when...	Possible cause
C1201	CONTROLLER FAILURE	Malfunction has occurred inside AWD control unit.	Internal malfunction of AWD control unit

DTC CONFIRMATION PROCEDURE

1. DTC REPRODUCTION PROCEDURE

Ⓟ With CONSULT

1. Turn the ignition switch OFF to ON.
2. Perform self-diagnosis for "ALL MODE AWD/4WD".

Is DTC "C1201" detected?

- YES >> Proceed to diagnosis procedure. Refer to [DLN-12. "Diagnosis Procedure"](#).
 NO >> INSPECTION END

Diagnosis Procedure

INFOID:000000008280056

1. PERFORM SELF-DIAGNOSIS

Ⓟ With CONSULT

1. Erase self-diagnostic results for "ALL MODE AWD/4WD".
2. Turn ignition switch OFF, and then wait 10 seconds or more.
3. Perform self-diagnosis for "ALL MODE AWD/4WD".

Is DTC "C1201" detected?

- YES >> Replace AWD control unit. Refer to [DLN-55. "Exploded View"](#).
 NO >> Check AWD control unit pin terminals for damage or loose connection with harness connector. If any items are damaged, repair or replace damaged parts.

C1203 ABS ACTUATOR AND ELECTRIC UNIT (CONTROL UNIT)

< DTC/CIRCUIT DIAGNOSIS >

[TRANSFER: TY30A]

C1203 ABS ACTUATOR AND ELECTRIC UNIT (CONTROL UNIT)

Description

INFOID:000000008280057

- Transmits the following signals via CAN communication to AWD control unit (without VDC).
 - Vehicle speed signal
 - Stop lamp switch signal (brake signal)
- Transmits AWD solenoid signal via AWD communication to AWD control unit (with VDC).

DTC Logic

INFOID:000000008280058

DTC DETECTION LOGIC

DTC	Items (CONSULT screen terms)	Diagnostic item is detected when...	Possible cause
C1203	ABS SYSTEM	Malfunction related to ABS system has been detected by ABS actuator and electric unit (control unit).	ABS malfunction <ul style="list-style-type: none">• Malfunction of ABS actuator and electric unit (control unit)• Vehicle speed signal error

DTC CONFIRMATION PROCEDURE

1. DTC REPRODUCTION PROCEDURE

With CONSULT

1. Start engine and drive at 30 km/h (19 MPH) or more for approx. 1 minute.
2. Perform self-diagnosis for "ALL MODE AWD/4WD".

Is DTC "C1203" detected?

- YES >> Proceed to diagnosis procedure. Refer to [DLN-13, "Diagnosis Procedure"](#).
NO >> INSPECTION END

Diagnosis Procedure

INFOID:000000008280059

1. PERFORM ABS ACTUATOR AND ELECTRIC UNIT (CONTROL UNIT) SELF-DIAGNOSIS

With CONSULT

Perform self-diagnosis for "ABS".

Is any error system detected?

- YES >> Check the error system.
NO >> GO TO 2.

2. PERFORM SELF-DIAGNOSIS

With CONSULT

1. Erase self-diagnostic results for "ALL MODE AWD/4WD".
2. Start engine and drive vehicle at 30 km/h (19 MPH) for at least 1 minute.
3. Make sure that ABS warning lamp turns OFF.
4. Perform self-diagnosis for "ALL MODE AWD/4WD".

Is DTC "C1203" detected?

- YES-1(Without VDC)>> Replace AWD control unit. Refer to [DLN-55, "Exploded View"](#).
YES-2 (With VDC)>> Replace ABS actuator and electric unit (control unit). Refer to [BRC-180, "Exploded View"](#).
NO >> Check AWD control unit pin terminals (without VDC) or ABS actuator and electric unit (control unit) pin terminals (with VDC) for damage or loose connection with harness connector. If any items are damaged, repair or replace damaged parts.

C1204 AWD SOLENOID

< DTC/CIRCUIT DIAGNOSIS >

[TRANSFER: TY30A]

C1204 AWD SOLENOID

Description

INFOID:000000008280060

Controls electric controlled coupling by command current from AWD control unit.

DTC Logic

INFOID:000000008280061

DTC DETECTION LOGIC

DTC	Items (CONSULT screen terms)	Diagnostic item is detected when...	Possible cause
C1204	4WD SOLENOID	Malfunction related to AWD solenoid has been detected.	<ul style="list-style-type: none"> Internal malfunction of electronic controlled coupling Malfunction of AWD solenoid power supply circuit (open or short) Malfunction of AWD solenoid command current

DTC CONFIRMATION PROCEDURE

1. DTC REPRODUCTION PROCEDURE

With CONSULT

- Turn the ignition switch OFF to ON.
- Perform self-diagnosis for "ALL MODE AWD/4WD".

Is DTC "C1204" detected?

- YES >> Proceed to diagnosis procedure. Refer to [DLN-14, "Diagnosis Procedure"](#).
- NO >> INSPECTION END

Diagnosis Procedure

INFOID:000000008280062

1. CHECK AWD SOLENOID POWER SUPPLY

- Turn the ignition switch OFF.
- Disconnect AWD control unit harness connector.
- Check the voltage between AWD control unit harness connector and ground.

AWD control unit		Ground	Voltage (Approx.)
Connector	Terminal		
M69	9	Ground	Battery voltage

Is the inspection result normal?

- YES >> GO TO 2.
- NO >> Perform the trouble diagnosis for power supply circuit. Refer to [DLN-26, "Diagnosis Procedure"](#).

2. CHECK AWD SOLENOID GROUND

- Turn the ignition switch OFF.
- Check the continuity between AWD control unit harness connector and ground.

AWD control unit		Ground	Continuity
Connector	Terminal		
M69	10	Ground	Existed
	11		

Is the inspection result normal?

- YES >> GO TO 3.
- NO >> Repair or replace damaged parts.

3. CHECK AWD SOLENOID CIRCUIT (1)

C1204 AWD SOLENOID

< DTC/CIRCUIT DIAGNOSIS >

[TRANSFER: TY30A]

Check the resistance between AWD control unit harness connector terminals.

AWD control unit			Resistance (Approx.)
Connector	Terminal		
M69	1	2	2.45 Ω

Is the inspection result normal?

YES >> GO TO 5.

NO >> GO TO 4.

4.CHECK AWD SOLENOID CIRCUIT (2)

1. Disconnect AWD solenoid harness connector.
2. Check the continuity between AWD control unit harness connector and AWD solenoid harness connector.

AWD control unit		AWD solenoid		Continuity
Connector	Terminal	Connector	Terminal	
M69	1	B251	1	Existed
	2		2	

3. Check the continuity between AWD control unit harness connector and the ground.

AWD control unit		Ground	Continuity
Connector	Terminal		
M69	1	Ground	Not existed
	2		

4. Check the continuity between AWD solenoid harness connector and the ground.

AWD solenoid		Ground	Continuity
Connector	Terminal		
B251	1	Ground	Not existed
	2		

Is the inspection result normal?

YES >> GO TO 5.

NO >> Repair or replace damaged parts.

5.CHECK AWD SOLENOID

Check the resistance between AWD solenoid harness connector terminals.

AWD solenoid			Resistance (Approx.)
Connector	Terminal		
B251	1	2	2.45 Ω

Is the inspection result normal?

YES >> GO TO 6.

NO >> AWD solenoid is malfunctioning. Replace electric controlled coupling. Refer to [DLN-100](#), "[Exploded View](#)".

6.CHECK TERMINALS AND HARNESS CONNECTORS

1. Check AWD control unit pin terminals for damage or loose connection with harness connector.
2. Check AWD solenoid pin terminals for damage or loose connection with harness connector.

Is the inspection result normal?

YES >> Replace AWD control unit. Refer to [DLN-55](#), "[Exploded View](#)".

NO >> Repair or replace damaged parts.

C1204 AWD SOLENOID

< DTC/CIRCUIT DIAGNOSIS >

[TRANSFER: TY30A]

Component Inspection

INFOID:000000008280063

1. CHECK AWD SOLENOID

1. Turn the ignition switch OFF.
2. Disconnect AWD solenoid harness connector.
3. Check the resistance between AWD solenoid harness connector terminals.

AWD solenoid		Resistance (Approx.)
Terminal		
1	2	2.45 Ω

Is the inspection result normal?

YES >> INSPECTION END

NO >> AWD solenoid is malfunctioning. Replace electric controlled coupling. Refer to [DLN-100](#).
["Exploded View"](#).

C1205 AWD ACTUATOR RELAY

< DTC/CIRCUIT DIAGNOSIS >

[TRANSFER: TY30A]

C1205 AWD ACTUATOR RELAY

Description

INFOID:000000008280064

AWD solenoid is supplied with voltage by the internal circuit of AWD control unit.

DTC Logic

INFOID:000000008280065

DTC DETECTION LOGIC

DTC	Items (CONSULT screen terms)	Diagnostic item is detected when...	Possible cause
C1205	4WD ACTUATOR RLY	Malfunction has been detected from AWD actuator relay integrated with AWD control unit, or malfunction related to AWD solenoid has been detected.	<ul style="list-style-type: none"> Internal malfunction of AWD control unit Malfunction of AWD solenoid power supply circuit (open or short)

DTC CONFIRMATION PROCEDURE

1. DTC REPRODUCTION PROCEDURE

With CONSULT

- Turn the ignition switch OFF to ON.
- Perform self-diagnosis for "ALL MODE AWD/4WD".

Is DTC "C1205" detected?

- YES >> Proceed to diagnosis procedure. Refer to [DLN-17, "Diagnosis Procedure"](#).
 NO >> INSPECTION END

Diagnosis Procedure

INFOID:000000008280066

1. CHECK AWD SOLENOID CIRCUIT (1)

- Turn the ignition switch OFF.
- Disconnect AWD control unit harness connector.
- Check the continuity between AWD control unit harness connector and the ground.

AWD control unit		Ground	Continuity
Connector	Terminal		
M69	1	Ground	Not existed
	2		

Is the inspection result normal?

- YES >> GO TO 2.
 NO >> GO TO 3.

2. CHECK TERMINALS AND HARNESS CONNECTORS

- Check AWD control unit pin terminals for damage or loose connection with harness connector.
- Check AWD solenoid pin terminals for damage or loose connection with harness connector.

Is the inspection result normal?

- YES >> After connecting each harness connector, perform DTC confirmation procedure again. When DTC "C1205" is detected, replace AWD control unit. Refer to [DLN-55, "Exploded View"](#).
 NO >> Repair or replace damaged parts.

3. CHECK AWD SOLENOID

- Disconnect AWD solenoid harness connector.
- Check the continuity between AWD solenoid harness connector and the ground.

C1205 AWD ACTUATOR RELAY

< DTC/CIRCUIT DIAGNOSIS >

[TRANSFER: TY30A]

AWD solenoid Terminal	Ground	Continuity
1	Ground	Not existed
2		

Is the inspection result normal?

YES >> GO TO 4.

NO >> AWD solenoid is malfunctioning. Replace electric controlled coupling. Refer to [DLN-100](#), "[Exploded View](#)".

4. CHECK THE AWD SOLENOID CIRCUIT (2)

Check the continuity between AWD control unit harness connector and the ground.

AWD control unit		Ground	Continuity
Connector	Terminal		
M69	1	Ground	Not existed
	2		

Is the inspection result normal?

YES >> GO TO 5.

NO >> Repair or replace damaged parts.

5. CHECK TERMINALS AND HARNESS CONNECTORS

1. Check AWD control unit pin terminals for damage or loose connection with harness connector.
2. Check AWD solenoid pin terminals for damage or loose connection with harness connector.

Is the inspection result normal?

YES >> After connecting each harness connector, perform DTC confirmation procedure again. When DTC "C1205" is detected, GO TO 1.

NO >> Repair or replace damaged parts.

C1210 ECM

Description

INFOID:000000008280067

Transmits the following signals via CAN communication to AWD control unit (without VDC) or ABS actuator and electric unit (control unit) (with VDC).

- Accelerator pedal position signal
- Engine speed signal

DTC Logic

INFOID:000000008280068

DTC DETECTION LOGIC

DTC	Items (CONSULT screen terms)	Diagnostic item is detected when...	Possible cause
C1210	ENGINE SIGNAL 1	Malfunction related to engine signal has been detected.	Malfunction of engine control system

DTC CONFIRMATION PROCEDURE

1. DTC REPRODUCTION PROCEDURE

With CONSULT

1. Start the engine. Drive the vehicle for a while.
2. Perform self-diagnosis for "ALL MODE AWD/4WD".

Is DTC "C1210" detected?

- YES >> Proceed to diagnosis procedure. Refer to [DLN-19, "Diagnosis Procedure"](#).
- NO >> INSPECTION END

Diagnosis Procedure

INFOID:000000008280069

1. PERFORM ECM SELF-DIAGNOSIS

With CONSULT

Perform self-diagnosis for "ENGINE".

Is any error system detected?

- YES >> Check the error system.
- NO >> GO TO 2.

2. PERFORM SELF-DIAGNOSIS

With CONSULT

1. Erase self-diagnostic results for "ALL MODE AWD/4WD".
2. Turn the ignition switch OFF.
3. Start the engine. Drive the vehicle for a while.
4. Stop the vehicle. Perform self-diagnosis for "ALL MODE AWD/4WD".

Is DTC "C1210" detected?

- YES-1 (Without VDC)>> Replace AWD control unit. Refer to [DLN-55, "Exploded View"](#).
- YES-2 (With VDC)>> Replace ABS actuator and electric unit (control unit). Refer to [BRC-180, "Exploded View"](#).
- NO >> Check AWD control unit pin terminals (without VDC) or ABS actuator and electric unit (control unit) pin terminals (with VDC) for damage or loose connection with harness connector. If any items are damaged, repair or replace damaged parts.

C1211 AWD COMMUNICATION

< DTC/CIRCUIT DIAGNOSIS >

[TRANSFER: TY30A]

C1211 AWD COMMUNICATION

Description

INFOID:000000008280070

- AWD communication transmits and receives signals between control units (ABS control unit to AWD control unit) connected with a dedicated line (single line).
- Transmits conditions of AWD solenoid signal via AWD communication for AWD control unit.
- Receives the following signals via AWD communication from AWD control unit.
 - AWD lock switch signal
 - AWD solenoid monitor signal

DTC Logic

INFOID:000000008280071

DTC DETECTION LOGIC

DTC	Items (CONSULT screen terms)	Diagnostic item is detected when...	Possible cause
C1211	4WD COMM CIRCUIT	AWD control unit cannot transmit signals to ABS actuator and electric unit (control unit).	<ul style="list-style-type: none">• Open of the harness of AWD communication line• AWD communication error<ul style="list-style-type: none">- Transmission by AWD control unit- Reception by ABS actuator and electric unit (control unit)

DTC CONFIRMATION PROCEDURE

1. DTC REPRODUCTION PROCEDURE

With CONSULT

1. Turn the ignition switch OFF to ON.
2. Perform self-diagnosis for "ALL MODE AWD/4WD".

Is DTC "C1211" detected?

- YES >> Proceed to diagnosis procedure. Refer to [DLN-20, "Diagnosis Procedure"](#).
NO >> INSPECTION END

Diagnosis Procedure

INFOID:000000008280072

1. CHECK AWD COMMUNICATION LINE

1. Turn the ignition switch OFF.
2. Disconnect AWD control unit harness connector and ABS actuator and electric unit (control unit).
3. Check the continuity between AWD control unit harness connector and ABS actuator and electric unit (control unit).

AWD control unit		ABS actuator and electric unit (control unit)		Continuity
Connector	Terminal	Connector	Terminal	
M69	6	E36	20	Existed

Is the inspection result normal?

- YES >> GO TO 2.
NO >> Repair or replace damaged parts.

2. CHECK TERMINALS AND HARNESS CONNECTORS

- Check AWD control unit pin terminals for damage or loose connection with harness connector.
- Check ABS actuator and electric unit (control unit) pin terminals for damage or loose connection with harness connector.

Is the inspection result normal?

- YES >> Replace AWD control unit, and then GO TO 3. Refer to [DLN-55, "Exploded View"](#).
NO >> Repair or replace damaged parts.

C1211 AWD COMMUNICATION

< DTC/CIRCUIT DIAGNOSIS >

[TRANSFER: TY30A]

3.PERFORM SELF-DIAGNOSIS

With CONSULT

1. Erase self-diagnostic results for "ALL MODE AWD/4WD" and "ABS".
2. Perform self-diagnosis for "ALL MODE AWD/4WD".

Is DTC "C1211" detected?

- YES >> Replace ABS actuator and electric unit (control unit). Refer to [BRC-180, "Exploded View"](#).
NO >> INSPECTION END

A
B
C
E
F
G
H
I
J
K
L
M
N
O
P

DLN

C1212 AWD COMMUNICATION

< DTC/CIRCUIT DIAGNOSIS >

[TRANSFER: TY30A]

C1212 AWD COMMUNICATION

Description

INFOID:000000008280073

- AWD communication transmits and receives signals between control units (ABS control unit to AWD control unit) connected with a dedicated line (single line).
- Transmits conditions of AWD solenoid signal via AWD communication for AWD control unit.
- Receives the following signals via AWD communication from AWD control unit.
 - AWD lock switch signal
 - AWD solenoid monitor signal

DTC Logic

INFOID:000000008280074

DTC DETECTION LOGIC

DTC	Items (CONSULT screen terms)	Diagnostic item is detected when...	Possible cause
C1212	4WD COMM CIRCUIT	AWD control unit cannot receive signals from ABS actuator and electric unit (control unit).	<ul style="list-style-type: none"> • Short of harness of AWD communication line on the power supply side or on the ground side. • AWD communication error <ul style="list-style-type: none"> - Reception by AWD control unit - Transmission by ABS actuator and electric unit (control unit)

DTC CONFIRMATION PROCEDURE

1. DTC REPRODUCTION PROCEDURE

Ⓜ With CONSULT

1. Turn the ignition switch OFF to ON.
2. Perform self-diagnosis for "ALL MODE AWD/4WD".

Is DTC "C1212" detected?

- YES >> Proceed to diagnosis procedure. Refer to [DLN-22. "Diagnosis Procedure"](#).
- NO >> INSPECTION END

Diagnosis Procedure

INFOID:000000008280075

1. CHECK AWD COMMUNICATION LINE (1)

1. Turn the ignition switch OFF.
2. Disconnect AWD control unit harness connector and ABS actuator and electric unit (control unit).
3. Check the voltage between AWD control unit harness connector and ground.

AWD control unit		Ground	Voltage (Approx.)
Connector	Terminal		
M69	6	Ground	0 V

Is the inspection result normal?

- YES >> GO TO 2.
- NO >> Repair or replace damaged parts.

2. CHECK AWD COMMUNICATION LINE (2)

Check the continuity between AWD control unit harness connector and ground.

AWD control unit		Ground	Continuity
Connector	Terminal		
M69	6	Ground	Not existed

Is the inspection result normal?

C1212 AWD COMMUNICATION

< DTC/CIRCUIT DIAGNOSIS >

[TRANSFER: TY30A]

- YES >> GO TO 3.
NO >> Repair or replace damaged parts.

3. CHECK TERMINALS AND HARNESS CONNECTORS

- Check ABS actuator and electric unit (control unit) pin terminals for damage or loose connection with harness connector.
- Check AWD control unit pin terminals for damage or loose connection with harness connector.

Is the inspection result normal?

- YES >> Replace ABS actuator and electric unit (control unit), and then GO TO 4. Refer to [BRC-180](#), "[Exploded View](#)".
NO >> Repair or replace damaged parts.

4. PERFORM SELF-DIAGNOSIS

With CONSULT

1. Erase self-diagnostic results for "ALL MODE AWD/4WD" and "ALL MODE AWD/4WD".
2. Perform self-diagnosis for "ALL MODE AWD/4WD".

Is DTC "C1212" detected?

- YES >> Replace AWD control unit. Refer to [DLN-55](#), "[Exploded View](#)".
NO >> INSPECTION END

A
B
C
DLN
E
F
G
H
I
J
K
L
M
N
O
P

U1000 CAN COMM CIRCUIT

< DTC/CIRCUIT DIAGNOSIS >

[TRANSFER: TY30A]

U1000 CAN COMM CIRCUIT

Description

INFOID:000000008280076

CAN (Controller Area Network) is a serial communication line for real time application. It is an on-vehicle multiplex communication line with high data communication speed and excellent error detection ability. Many electronic control units are equipped onto a vehicle, and each control unit shares information and links with other control units during operation (not independent). In CAN communication, control units are connected with 2 communication lines (CAN-H line, CAN-L line) allowing a high rate of information transmission with less wiring. Each control unit transmits/receives data but selectively reads required data only. Refer to [LAN-26, "CAN Communication Signal Chart"](#).

DTC Logic

INFOID:000000008280077

DTC DETECTION LOGIC

DTC	Items (CONSULT screen terms)	Diagnostic item is detected when...	Possible cause
U1000	CAN COMM CIRCUIT	<ul style="list-style-type: none">• AWD control unit is not transmitting/receiving CAN communication signal for 2 seconds or more (without VDC).• ABS actuator and electric unit (control unit) is not transmitting/receiving CAN communication signal for 2 seconds or more (with VDC).	<ul style="list-style-type: none">• CAN communication error• Malfunction of AWD control unit (without VDC)• Malfunction of ABS actuator and electric unit (control unit) (with VDC)

DTC CONFIRMATION PROCEDURE

1. DTC REPRODUCTION PROCEDURE

With CONSULT

1. Turn the ignition switch OFF to ON.
2. Perform self-diagnosis for "ALL MODE AWD/4WD".

Is DTC "U1000" detected?

- YES >> Proceed to diagnosis procedure. Refer to [DLN-24, "Diagnosis Procedure"](#).
NO >> INSPECTION END

Diagnosis Procedure

INFOID:000000008280078

Proceed to [LAN-16, "Trouble Diagnosis Flow Chart"](#).

U1010 CONTROL UNIT (CAN)

< DTC/CIRCUIT DIAGNOSIS >

[TRANSFER: TY30A]

U1010 CONTROL UNIT (CAN)

Description

INFOID:000000008280079

CAN (Controller Area Network) is a serial communication line for real time application. It is an on-vehicle multiplex communication line with high data communication speed and excellent error detection ability. Many electronic control units are equipped onto a vehicle, and each control unit shares information and links with other control units during operation (not independent). In CAN communication, control units are connected with 2 communication lines (CAN-H line, CAN-L line) allowing a high rate of information transmission with less wiring. Each control unit transmits/receives data but selectively reads required data only. Refer to [LAN-26, "CAN Communication Signal Chart"](#).

DTC Logic

INFOID:000000008280080

DTC DETECTION LOGIC

DTC	Items (CONSULT- screen terms)	Diagnostic item is detected when...	Possible cause
U1010	CONTROL UNIT (CAN)	<ul style="list-style-type: none">• Detecting error during the initial diagnosis of CAN controller of AWD control unit (without VDC).• Detecting error during the initial diagnosis of CAN controller of ABS actuator and electric unit (control unit) (with VDC).	<ul style="list-style-type: none">• Malfunction of AWD control unit (without VDC)• Malfunction of ABS actuator and electric unit (control unit) (with VDC)

DTC CONFIRMATION PROCEDURE

1. DTC REPRODUCTION PROCEDURE

With CONSULT

1. Turn the ignition switch OFF to ON.
2. Perform self-diagnosis for "ALL MODE AWD/4WD".

Is DTC "U1010" detected?

- YES >> Proceed to diagnosis procedure. Refer to [DLN-25, "Diagnosis Procedure"](#).
NO >> INSPECTION END

Diagnosis Procedure

INFOID:000000008280081

1. CHECK AWD CONTROL UNIT

Check AWD control unit harness connector for disconnection and deformation.

Is the inspection result normal?

- YES-1 (Without VDC)>> Replace AWD control unit. Refer to [DLN-55, "Exploded View"](#).
YES-2 (With VDC)>> Replace ABS actuator and electric unit (control unit). Refer to [BRC-180, "Exploded View"](#).
NO >> Repair or replace damaged parts.

POWER SUPPLY AND GROUND CIRCUIT

< DTC/CIRCUIT DIAGNOSIS >

[TRANSFER: TY30A]

POWER SUPPLY AND GROUND CIRCUIT

Description

INFOID:000000008280082

Supplies power to AWD control unit.

NOTE:

AWD system of vehicle with VDC shares various controls with ABS actuator and electric unit (control unit). Therefore, checking power supply and ground earth circuit is required.

Diagnosis Procedure

INFOID:000000008280083

1. CHECK POWER SUPPLY AND GROUND CIRCUIT [ABS ACTUATOR AND ELECTRIC UNIT (CONTROL UNIT)]

Perform the trouble diagnosis for power supply and ground circuit. Refer to [BRC-107. "Diagnosis Procedure"](#).

Is the inspection result normal?

YES >> GO TO 2.

NO >> Repair or replace the malfunctioning part.

2. CHECK AWD CONTROL UNIT POWER SUPPLY (1)

1. Turn the ignition switch OFF.
2. Disconnect AWD control unit harness connector.
3. Check the voltage between AWD control unit harness connector and ground.

AWD control unit		—	Voltage (Approx.)
Connector	Terminal		
M69	7	Ground	0 V

4. Turn the ignition switch ON.

CAUTION:

Never start the engine.

5. Check the voltage between AWD control unit harness connector and ground.

AWD control unit		—	Voltage
Connector	Terminal		
M69	7	Ground	Battery voltage

Is the inspection result normal?

YES >> GO TO 4.

NO >> GO TO 3.

3. CHECK AWD CONTROL UNIT POWER SUPPLY (2)

1. Turn the ignition switch OFF.
2. Check the 10A fuse (#59).
3. Disconnect IPDM E/R harness connector.
4. Check the continuity between AWD control unit harness connector and IPDM E/R harness connector.

AWD control unit		IPDM E/R		Continuity
Connector	Terminal	Connector	Terminal	
M69	7	E15	59	Existed

5. Check the continuity between AWD control unit harness connector and the ground.

AWD control unit		—	Continuity
Connector	Terminal		
M69	7	Ground	Not existed

Is the inspection result normal?

POWER SUPPLY AND GROUND CIRCUIT

< DTC/CIRCUIT DIAGNOSIS >

[TRANSFER: TY30A]

- YES >> Perform the trouble diagnosis for ignition power supply circuit. Refer to [PG-18, "Wiring Diagram - IGNITION POWER SUPPLY -"](#).
- NO >> Repair or replace error-detected parts.

4.CHECK AWD SOLENOID POWER SUPPLY (1)

1. Turn the ignition switch OFF.
2. Check the voltage between AWD control unit harness connector and ground.

AWD control unit		—	Voltage
Connector	Terminal		
M69	9	Ground	Battery voltage

3. Turn the ignition switch ON.
CAUTION:
Never start the engine.
4. Check the voltage between AWD control unit harness connector and ground.

AWD control unit		—	Voltage
Connector	Terminal		
M69	9	Ground	Battery voltage

Is the inspection result normal?

- YES >> GO TO 6.
- NO >> GO TO 5.

5.CHECK AWD SOLENOID POWER SUPPLY (2)

1. Turn the ignition switch OFF.
2. Check the 10A fuse (#12).

Is the inspection result normal?

- YES >> Perform the trouble diagnosis for power supply circuit. Refer to [PG-6, "Wiring Diagram - BATTERY POWER SUPPLY -"](#).
- NO >> Repair or replace error-detected parts.

6.CHECK AWD CONTROL UNIT GROUND

1. Turn the ignition switch OFF.
2. Check the continuity between AWD control unit harness connector and ground.

AWD control unit		—	Continuity
Connector	Terminal		
M69	10	Ground	Existed
	11		

Is the inspection result normal?

- YES >> INSPECTION END
- NO >> Repair or replace error-detected parts.

A
B
C
DLN
E
F
G
H
I
J
K
L
M
N
O
P

AWD LOCK SWITCH

< DTC/CIRCUIT DIAGNOSIS >

[TRANSFER: TY30A]

AWD LOCK SWITCH

Description

INFOID:000000008280084

Able to select AUTO or LOCK mode.

Diagnosis Procedure

INFOID:000000008280085

1. CHECK AWD LOCK SWITCH

1. Turn the ignition switch OFF.
2. Remove AWD lock switch.
3. Check the continuity between AWD lock switch connector terminals.

AWD lock switch				Continuity
Connector	Terminal		Condition	
M8	1	3	AWD lock switch: AUTO (OFF)	Not existed
			AWD lock switch: LOCK (ON) (State of hold of LOCK position)	Existed

Is the inspection result normal?

- YES >> GO TO 2.
 NO >> Replace AWD lock switch.

2. CHECK AWD LOCK SWITCH CIRCUIT (1)

Check the continuity between AWD lock switch harness connector and ground.

AWD lock switch		Ground	Continuity
Connector	Terminal		
M8	3	Ground	Existed

Is the inspection result normal?

- YES >> GO TO 3.
 NO >> Repair or replace damaged parts.

3. CHECK AWD LOCK SWITCH CIRCUIT (2)

1. Disconnect AWD control unit harness connector.
2. Check the continuity between AWD control unit harness connector and AWD lock switch harness connector.

AWD control unit		AWD lock switch		Continuity
Connector	Terminal	Connector	Terminal	
M69	5 ^{*1}	M8	1	Existed
	14 ^{*2}			

*1: With VDC

*2: Without VDC

3. Check the continuity between AWD control unit harness connector and ground.

AWD control unit		Ground	Continuity
Connector	Terminal		
M69	5 ^{*1}	Ground	Not existed
	14 ^{*2}		

*1: With VDC

*2: Without VDC

Is the inspection result normal?

AWD LOCK SWITCH

[TRANSFER: TY30A]

< DTC/CIRCUIT DIAGNOSIS >

- YES >> GO TO 4.
NO >> Repair or replace damaged parts.

4.CHECK AWD CONTROL UNIT OUTPUT SIGNAL

1. Connect AWD control unit harness connector.
2. Turn the ignition switch ON.
CAUTION:
Never start the engine.
3. Check the voltage between AWD lock switch harness connector and ground.

AWD lock switch		Ground	Voltage (Approx.)
Connector	Terminal		
M8	1	Ground	Battery voltage

Is the inspection result normal?

- YES >> Check each harness connector pin terminal for disconnection.
NO >> Replace AWD control unit. Refer to [DLN-55. "Exploded View"](#).

Component Inspection

INFOID:000000008280086

1.CHECK AWD LOCK SWITCH

1. Turn the ignition switch OFF.
2. Remove AWD lock switch.
3. Check the continuity between AWD lock switch connector terminals.

AWD lock switch		Condition	Continuity
Terminal			
1	3	When releasing AWD lock switch.	Not existed
		When AWD lock switch is hold pressed.	Existed

Is the inspection result normal?

- YES >> INSPECTION END
NO >> Replace AWD lock switch.

AWD WARNING LAMP

< DTC/CIRCUIT DIAGNOSIS >

[TRANSFER: TY30A]

AWD WARNING LAMP

Description

INFOID:000000008280087

- Turns ON when there is a malfunction in AWD system. AWD warning lamp indicates the vehicle is in fail-safe mode and shifting to front-wheel drive or 4-wheel drive (rear-wheels still have some driving torque).
- Also turns ON when ignition switch is turned ON, for the purpose of lamp check. Turns OFF after the engine starts if system is normal.

AWD WARNING LAMP INDICATION

Condition	AWD warning lamp
Lamp check	Turns ON when ignition switch is turned ON. Turns OFF after engine start.
AWD system malfunction	ON
Protection function is activated due to heavy load to electric controlled coupling. (AWD system is not malfunctioning and AWD system changes to front wheel drive.)	Quick blinking: 2 times/second (Blinking in approx. 1 minute and then turning OFF)
Large difference in diameter of front/rear tires	Slow blinking: 1 time/2 seconds (Continuing to blink until turning ignition switch OFF)
Other than above (system normal)	OFF

CAUTION:

- AWD warning lamp also turns ON due to data reception error, CAN communication error etc.
- AWD warning lamp also turns ON due to data reception error, AWD communication error (with VDC).

Diagnosis Procedure

INFOID:000000008280088

1. CHECK POWER SUPPLY AND GROUND CIRCUIT

Perform the trouble diagnosis for power supply and ground circuit. Refer to [DLN-26, "Diagnosis Procedure"](#).

Is the inspection result normal?

YES-1 (With VDC)>>GO TO 2.

YES-2 (Without VDC)>>GO TO 3.

NO >> Repair or replace the malfunctioning part.

2. CHECK POWER SUPPLY AND GROUND CIRCUIT [ABS ACTUATOR AND ELECTRIC UNIT (CONTROL UNIT)]

Perform the trouble diagnosis for power supply and ground circuit. Refer to [BRC-107, "Diagnosis Procedure"](#).

Is the inspection result normal?

YES >> GO TO 3.

NO >> Repair or replace the malfunctioning part.

3. PERFORM SELF-DIAGNOSIS

With CONSULT

Perform self-diagnosis for "ALL MODE AWD/4WD".

Is DTC "U1000" detected?

YES >> CAN specification chart. Refer to [LAN-16, "Trouble Diagnosis Flow Chart"](#).

NO >> GO TO 4.

4. CHECK AWD WARNING LAMP SIGNAL

With CONSULT

1. Turn the ignition switch ON.

CAUTION:

Never start the engine.

2. Check "4WD WARN LAMP" of CONSULT "DATA MONITOR" for "ALL MODE AWD/4WD".

Does the item on "DATA MONITOR" indicate "On"?

YES >> GO TO 5.

NO-1 (Without VDC)>>Replace AWD control unit. Refer to [DLN-55, "Exploded View"](#).

AWD WARNING LAMP

< DTC/CIRCUIT DIAGNOSIS >

[TRANSFER: TY30A]

NO-2 (With VDC)>>Replace ABS actuator and electric unit (control unit). Refer to [BRC-180. "Exploded View"](#).

A

5.CHECK COMBINATION METER POWER SUPPLY CIRCUIT

Perform the trouble diagnosis for combination meter power supply circuit. Refer to [MWI-55. "COMBINATION METER : Diagnosis Procedure"](#).

B

Is the inspection result normal?

YES >> INSPECTION END

C

NO >> Repair or replace the malfunctioning part.

DLN

E

F

G

H

I

J

K

L

M

N

O

P

AWD LOCK INDICATOR LAMP

< DTC/CIRCUIT DIAGNOSIS >

[TRANSFER: TY30A]

AWD LOCK INDICATOR LAMP

Description

INFOID:000000008280089

The following is the indications of indicator lamp after engine start.

AWD LOCK INDICATOR LAMP

Condition	AWD LOCK indicator lamp
Lamp check	Turns ON for approx. 1 second when ignition switch is turned ON.
AUTO mode	OFF
LOCK mode	ON

Diagnosis Procedure

INFOID:000000008280090

1. CHECK AWD WARNING LAMP

Start engine and drive at 30 km/h (19 MPH) or more for approx. 1 minute.

Does AWD warning lamp turn ON?

- YES >> Proceed to [DLN-30, "Diagnosis Procedure"](#).
- NO >> GO TO 2.

2. CHECK AWD LOCK SWITCH

Perform the trouble diagnosis for AWD lock switch. Refer to [DLN-28, "Diagnosis Procedure"](#).

Is the inspection result normal?

- YES >> GO TO 3.
- NO >> Repair or replace the malfunctioning part.

3. CHECK AWD LOCK INDICATOR LAMP SIGNAL (1)

Ⓟ With CONSULT

1. Start the engine.

CAUTION:

Stop the vehicle.

2. Change AWD lock switch to "LOCK" from "AUTO".
3. Check "4WD MODE MON" of CONSULT "DATA MONITOR" for "ALL MODE AWD/4WD".

Does the item on "DATA MONITOR" indicate "LOCK"?

- YES >> GO TO 5.
- NO-1 (Without VDC)>>Replace AWD control unit. Refer to [DLN-55, "Exploded View"](#).
- NO-2 (With VDC)>>Replace ABS actuator and electric unit (control unit), and then GO TO 4. Refer to [BRC-180, "Exploded View"](#).

4. CHECK AWD LOCK INDICATOR LAMP SIGNAL (2)

Ⓟ With CONSULT

Check "4WD MODE MON" of CONSULT "DATA MONITOR" for "ALL MODE AWD/4WD".

Does the item on "DATA MONITOR" indicate "LOCK"?

- YES >> GO TO 5.
- NO >> Replace AWD control unit. Refer to [DLN-55, "Exploded View"](#).

5. CHECK COMBINATION METER POWER SUPPLY CIRCUIT

Perform the trouble diagnosis for combination meter power supply circuit. Refer to [MWI-55, "COMBINATION METER : Diagnosis Procedure"](#).

Is the inspection result normal?

- YES >> INSPECTION END
- NO >> Repair or replace the malfunctioning part.

AWD CONTROL UNIT

< ECU DIAGNOSIS INFORMATION >

[TRANSFER: TY30A]

ECU DIAGNOSIS INFORMATION

AWD CONTROL UNIT

Reference Value (Without VDC)

INFOID:000000008280091

VALUES ON THE DIAGNOSIS TOOL

NOTE:

The following table includes information (items) inapplicable to this vehicle. For information (items) applicable to this vehicle, refer to CONSULT display items.

Monitor item	Condition		Value/Status
FR RH SENSOR	Vehicle stopped		0.00 km/h (0.00 mph)
	Vehicle running CAUTION: Check air pressure of tire under standard condition.		Approx. equal to the indication on speedometer (Inside of ±10%)
FR LH SENSOR	Vehicle stopped		0.00 km/h (0.00 mph)
	Vehicle running CAUTION: Check air pressure of tire under standard condition.		Approx. equal to the indication on speedometer (Inside of ±10%)
RR RH SENSOR	Vehicle stopped		0.00 km/h (0.00 mph)
	Vehicle running CAUTION: Check air pressure of tire under standard condition.		Approx. equal to the indication on speedometer (Inside of ±10%)
RR LH SENSOR	Vehicle stopped		0.00 km/h (0.00 mph)
	Vehicle running CAUTION: Check air pressure of tire under standard condition.		Approx. equal to the indication on speedometer (Inside of ±10%)
BATTERY VOLT	Always		Battery voltage
THRTL POS SEN	When depressing accelerator pedal (Value rises gradually in response to throttle position.)		0 – 100%
ETS SOLENOID	Engine running • At idle speed	AWD LOCK indicator lamp: OFF	Approx. 0.000 A
		AWD LOCK indicator lamp: ON	Approx. 0.000 A
	Engine running • 3,000 rpm or more constant	AWD LOCK indicator lamp: OFF	Approx. 0.000 – 1.800 A*
		AWD LOCK indicator lamp: ON	Approx. 1.800 A
STOP LAMP SW	Brake pedal: Depressed		On
	Brake pedal: Released		Off
ENG SPEED SIG	Engine stopped (Engine speed: Less than 400 rpm)		Stop
	Engine running (Engine speed: 400 rpm or more)		Run
ETS ACTUATOR	Engine stopped (Ignition switch: ON)		Off
	Engine running		On
4WD WARN LAMP	AWD warning lamp: ON		On
	AWD warning lamp: OFF		Off
4WD MODE SW	Releasing AWD lock switch.		AUTO
	AWD lock switch is hold pressed.		LOCK
4WD MODE MON	AWD LOCK indicator lamp: OFF		AUTO
	AWD LOCK indicator lamp: ON	Vehicle speed below 10 km/h (6 mph)	LOCK
		Vehicle speed above 10 km/h (6 mph)	AUTO

AWD CONTROL UNIT

< ECU DIAGNOSIS INFORMATION >

[TRANSFER: TY30A]

Monitor item	Condition	Value/Status
DIS-TIRE MONI	Vehicle running with normal size tire installed	0 – 4 mm
	Vehicle running with improper size tire installed (Front/rear tire size difference, wear condition)	4 – 8 mm, 8 – mm
P BRAKE SW	Parking brake operated	On
	Parking brake not operated	Off

*: The values are changed by throttle opening and engine speed.

TERMINAL LAYOUT

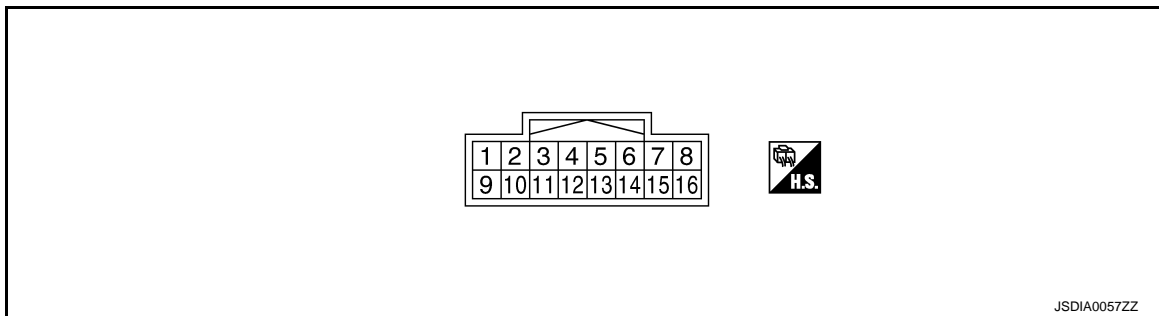

PHYSICAL VALUES

Terminal No. (Wire color)		Description	Input/ Output	Condition	Value (Approx.)
+	-				
1 (LG)	Ground	AWD solenoid power supply	Output	Engine speed: At idle	AWD LOCK indicator lamp: OFF 0 V
					AWD LOCK indicator lamp: ON 0 V
				Engine speed: 3,000 rpm or more constant	AWD LOCK indicator lamp: OFF 2.5 V*
					AWD LOCK indicator lamp: ON 8 V
2 (G)	Ground	AWD solenoid ground	—	Engine speed: At idle	0 V
				Engine speed: 3,000 rpm or more constant	0 V
7 (GR)	Ground	Ignition switch	Input	Ignition switch: ON	Battery voltage
				Ignition switch: OFF	0 V
8 (L)	—	CAN-H	Input/ Output	—	—
9 (W)	Ground	Power supply (AWD solenoid)	Input	Ignition switch: ON	Battery voltage
				Ignition switch: OFF	Battery voltage
10 (B)	Ground	Ground	—	Always	0 V
11 (B)	Ground	Ground	—	Always	0 V
14 (BR)	Ground	AWD lock switch	Output	Ignition switch: ON	Releasing AWD lock switch Battery voltage
					AWD lock switch is hold pressed. 0 V
16 (P)	—	CAN-L	Input/ Output	—	—

*: The values are changed by throttle opening and engine speed.

CAUTION:

When using circuit tester to measure voltage for inspection, be sure not to extend forcibly any connector terminals.

AWD CONTROL UNIT

< ECU DIAGNOSIS INFORMATION >

[TRANSFER: TY30A]

Reference Value (With VDC)

INFOID:000000008280092

VALUES ON THE DIAGNOSIS TOOL

NOTE:

The following table includes information (items) inapplicable to this vehicle. For information (items) applicable to this vehicle, refer to CONSULT display items.

Monitor item	Condition	Value/Status	
FR RH SENSOR	Vehicle stopped	0.00 km/h (0.00 mph)	
	Vehicle running CAUTION: Check air pressure of tire under standard condition.	Approx. equal to the indication on speedometer (Inside of ±10%)	
FR LH SENSOR	Vehicle stopped	0.00 km/h (0.00 mph)	
	Vehicle running CAUTION: Check air pressure of tire under standard condition.	Approx. equal to the indication on speedometer (Inside of ±10%)	
RR RH SENSOR	Vehicle stopped	0.00 km/h (0.00 mph)	
	Vehicle running CAUTION: Check air pressure of tire under standard condition.	Approx. equal to the indication on speedometer (Inside of ±10%)	
RR LH SENSOR	Vehicle stopped	0.00 km/h (0.00 mph)	
	Vehicle running CAUTION: Check air pressure of tire under standard condition.	Approx. equal to the indication on speedometer (Inside of ±10%)	
BATTERY VOLT	Always	Battery voltage	
THRTL POS SEN	When depressing accelerator pedal (Value rises gradually in response to throttle position.)	0 – 100%	
ETS SOLENOID	Engine running • At idle speed	AWD LOCK indicator lamp: OFF	Approx. 0.000 A
		AWD LOCK indicator lamp: ON	Approx. 0.000 A
	Engine running • 3,000 rpm or more constant	AWD LOCK indicator lamp: OFF	Approx. 0.000 – 1.800 A*
		AWD LOCK indicator lamp: ON	Approx. 1.800 A
STOP LAMP SW	Brake pedal: Depressed	On	
	Brake pedal: Released	Off	
ENG SPEED SIG	Engine stopped (Engine speed: Less than 400 rpm)	Stop	
	Engine running (Engine speed: 400 rpm or more)	Run	
ETS ACTUATOR	Engine stopped (Ignition switch: ON)	Off	
	Engine running	On	
4WD WARN LAMP	AWD warning lamp: ON	On	
	AWD warning lamp: OFF	Off	
4WD MODE SW	Releasing AWD lock switch.	AUTO	
	AWD lock switch is hold pressed.	LOCK	
4WD MODE MON	AWD LOCK indicator lamp: OFF		AUTO
	AWD LOCK indicator lamp: ON	Vehicle speed below 10 km/h (6 mph)	LOCK
		Vehicle speed above 10 km/h (6 mph)	AUTO
DIS-TIRE MONI	Vehicle running with normal size tire installed	0 – 4 mm	
	Vehicle running with improper size tire installed (Front/rear tire size difference, wear condition)	4 – 8 mm, 8 – mm	

A
B
C
DLN
E
F
G
H
I
J
K
L
M
N
O
P

AWD CONTROL UNIT

< ECU DIAGNOSIS INFORMATION >

[TRANSFER: TY30A]

Monitor item	Condition	Value/Status
P BRAKE SW	Parking brake operated	On
	Parking brake not operated	Off

*: The values are changed by throttle opening and engine speed.

TERMINAL LAYOUT

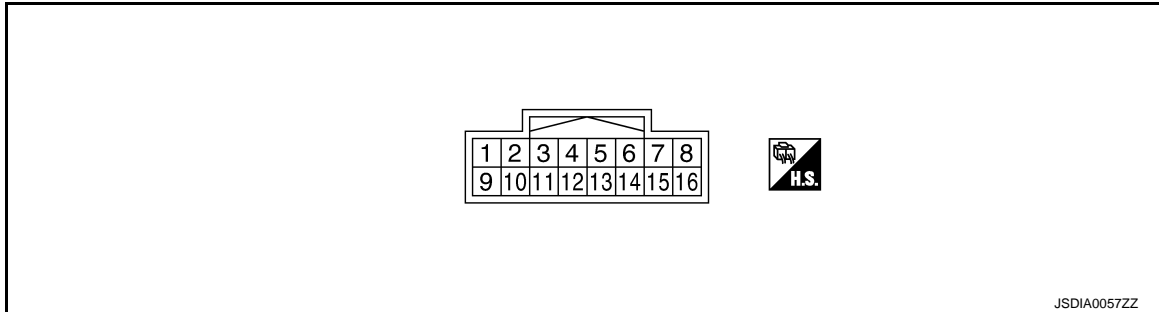

PHYSICAL VALUES

Terminal No. (Wire color)		Description	Input/ Output	Condition		Value (Approx.)
+	-			Signal name		
1 (LG)	Ground	AWD solenoid power supply	Output	Engine speed: At idle	AWD LOCK indicator lamp: OFF	0 V
					AWD LOCK indicator lamp: ON	0 V
				Engine speed: 3,000 rpm or more constant	AWD LOCK indicator lamp: OFF	2.5 V*
					AWD LOCK indicator lamp: ON	8 V
2 (G)	Ground	AWD solenoid ground	—	Engine speed: At idle		0 V
				Engine speed: 3,000 rpm or more constant		0 V
5 (BR)	Ground	AWD lock switch	Output	Ignition switch: ON	Releasing AWD lock switch	Battery voltage
				Ignition switch: ON	AWD lock switch is hold pressed.	0 V
6 (L)	—	AWD communication	Input/ Output	—		—
7 (GR)	Ground	Ignition switch	Input	Ignition switch: ON		Battery voltage
				Ignition switch: OFF		0 V
9 (W)	Ground	Power supply (AWD solenoid)	Input	Ignition switch: ON		Battery voltage
				Ignition switch: OFF		Battery voltage
10 (B)	Ground	Ground	—	Always		0 V
11 (B)	Ground	Ground	—	Always		0 V

*: The values are changed by throttle opening and engine speed.

CAUTION:

When using circuit tester to measure voltage for inspection, be sure not to extend forcibly any connector terminals.

Wiring Diagram - AWD SYSTEM -

INFOID:000000008280093

For connector terminal arrangements, harness layouts, and alphabets in a (option abbreviation; if not described in wiring diagram), refer to [GI-12. "Connector Information"](#).

AWD CONTROL UNIT

< ECU DIAGNOSIS INFORMATION >

[TRANSFER: TY30A]

AWD SYSTEM

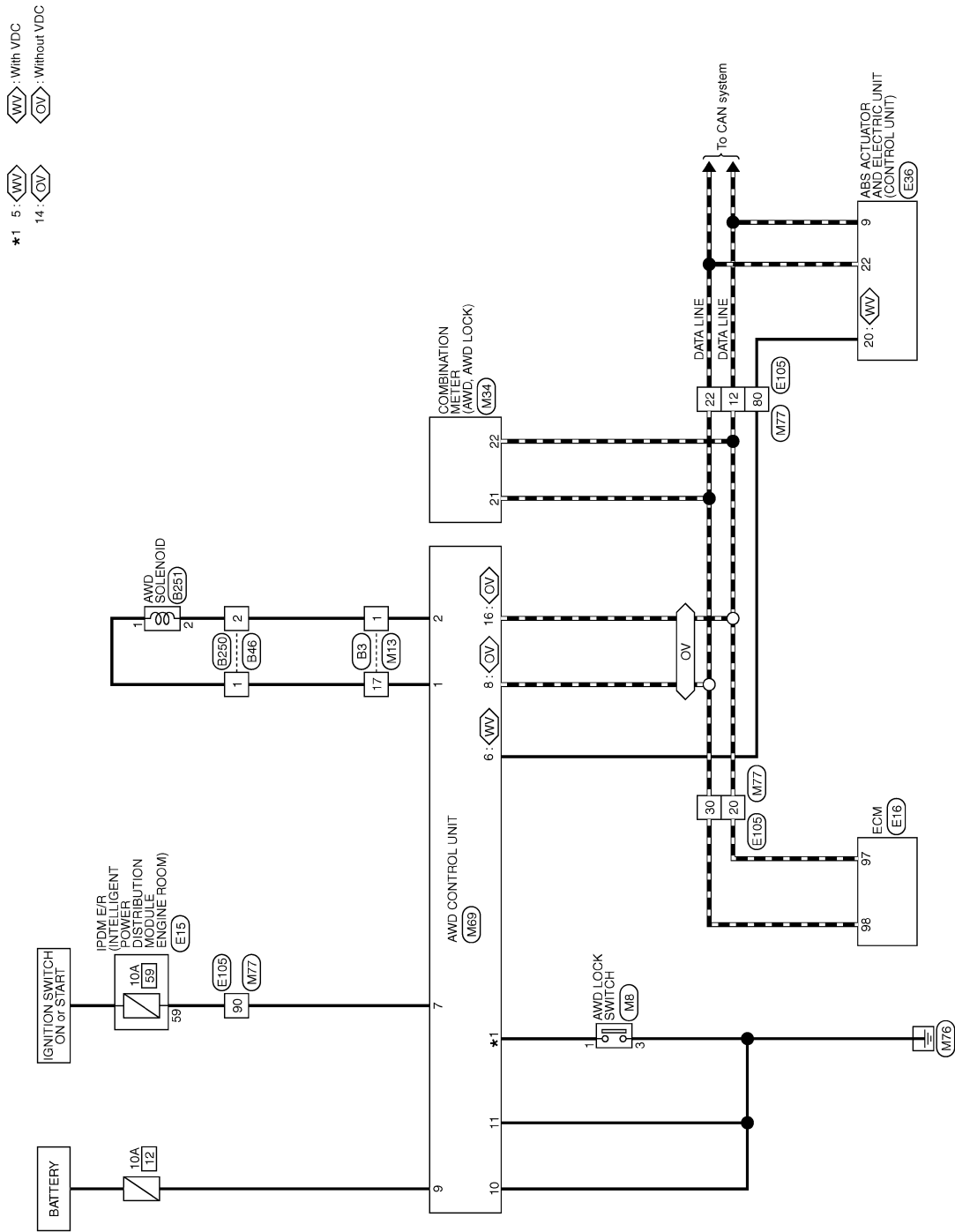

*1 5: <WV> : With VDC
 14: <OV> : Without VDC

2012/05/23

JRDWC0399GB

INFOID:0000000008280094

Fail Safe

AWD system

- If any malfunction occurs in AWD electrical system, and control unit detects the malfunction, AWD warning lamp on combination meter turns ON to indicate system malfunction.
- When AWD warning lamp is ON, vehicle changes to front-wheel drive or shifts to 4-wheel drive (rear-wheels still have some driving torque).

A
 B
 C
DLN
 E
 F
 G
 H
 I
 J
 K
 L
 M
 N
 O
 P

AWD CONTROL UNIT

< ECU DIAGNOSIS INFORMATION >

[TRANSFER: TY30A]

- AWD system activates its protection function (shuts down AWD system temporarily) if AWD system detects high load continuously or the front wheel tire size differs from the rear tire size. (AWD system is automatically restored if AWD system no longer detects any overload or the tire size difference is eliminated.)

Mode	Warning lamp	DTC	Detected area (Error area)	Error area and root cause
Protection function	Blinking *1	—	AWD control unit	Transfer assembly in protection mode. It is not malfunction. (Internal temperature rise of electronic controlled coupling)
	Blinking *2	—	Outer diameters of front and rear wheel tires	Malfunction in each tire or different tire diameter
Fail-safe	ON	C1201	AWD control unit	Internal malfunction of AWD control unit
		C1203	ABS actuator and electric unit (control unit)	<ul style="list-style-type: none"> • Malfunction of ABS actuator and electric unit (control unit) • Vehicle speed signal error
		C1204	AWD solenoid	<ul style="list-style-type: none"> • Internal malfunction of electronic controlled coupling • Malfunction of AWD solenoid power supply circuit (open or short) • Malfunction of AWD solenoid command current
		C1205	<ul style="list-style-type: none"> • AWD control unit • AWD solenoid 	<ul style="list-style-type: none"> • Internal malfunction of AWD control unit • Malfunction of AWD solenoid power supply circuit (open or short)
		C1210	ECM	Malfunction of engine control system
		C1211	AWD communication line/ AWD control unit/ABS actuator and electric unit (control unit)	<ul style="list-style-type: none"> • Open of the harness of AWD communication line • AWD communication error - Transmission by AWD control unit - Reception by ABS actuator and electric unit (control unit)
		C1212	AWD communication line/ ABS actuator and electric unit (control unit)/AWD control unit	<ul style="list-style-type: none"> • Short of harness of AWD communication line on the power supply side or on the ground side. • AWD communication error - Reception by AWD control unit - Transmission by ABS actuator and electric unit (control unit)
		U1000	CAN communication line	<ul style="list-style-type: none"> • CAN communication error • Malfunction of AWD control unit (without VDC) • Malfunction of ABS actuator and electric unit (control unit) (with VDC)
U1010	AWD control unit	<ul style="list-style-type: none"> • Malfunction of AWD control unit (without VDC) • Malfunction of ABS actuator and electric unit (control unit) (with VDC) 		

*1: Quick blinking: 2 times/second (blinking for approx. 1 minute and then turned OFF)

*2: Slow blinking: 1 time/2 seconds (continuing to blink until ignition switch is turned OFF)

DTC Inspection Priority Chart

INFOID:000000008280095

If some DTCs are displayed at the same time, perform inspections one by one based on the following priority chart.

Priority	Detected items (DTC)
1	<ul style="list-style-type: none"> • U1000 CAN COMM CIRCUIT • U1010 CONTROL UNIT (CAN)
2	<ul style="list-style-type: none"> • C1201 CONTROLLER FAILURE • C1205 4WD ACTUATOR RLY • C1211 4WD COMM CIRCUIT • C1212 4WD COMM CIRCUIT
3	<ul style="list-style-type: none"> • C1204 4WD SOLENOID
4	<ul style="list-style-type: none"> • C1203 ABS SYSTEM • C1210 ENGINE SIGNAL 1

AWD CONTROL UNIT

< ECU DIAGNOSIS INFORMATION >

[TRANSFER: TY30A]

DTC Index

INFOID:000000008280096

DTC	Items (CONSULT screen terms)	Reference
C1201	CONTROLLER FAILURE	DLN-12, "DTC Logic"
C1203	ABS SYSTEM	DLN-13, "DTC Logic"
C1204	4WD SOLENOID	DLN-14, "DTC Logic"
C1205	4WD ACTUATOR RLY	DLN-17, "DTC Logic"
C1210	ENGINE SIGNAL 1	DLN-19, "DTC Logic"
C1211	4WD COMM CIRCUIT	DLN-20, "DTC Logic"
C1212	4WD COMM CIRCUIT	DLN-22, "DTC Logic"
U1000	CAN COMM CIRCUIT	DLN-24, "DTC Logic"
U1010	CONTROL UNIT (CAN)	DLN-25, "DTC Logic"

A
B
C
DLN
E
F
G
H
I
J
K
L
M
N
O
P

AWD WARNING LAMP DOES NOT TURN ON

< SYMPTOM DIAGNOSIS >

[TRANSFER: TY30A]

SYMPTOM DIAGNOSIS

AWD WARNING LAMP DOES NOT TURN ON

Description

INFOID:000000008280097

AWD warning lamp does not turn ON when the ignition switch is turned to ON.

Diagnosis Procedure

INFOID:000000008280098

1. CHECK AWD WARNING LAMP

Perform the trouble diagnosis for AWD warning lamp. Refer to [DLN-30. "Diagnosis Procedure"](#).

Is the inspection result normal?

- YES >> Check each harness connector pin terminal for malfunction or disconnection.
- NO >> Repair or replace the malfunctioning part.

AWD WARNING LAMP DOES NOT TURN OFF

< SYMPTOM DIAGNOSIS >

[TRANSFER: TY30A]

AWD WARNING LAMP DOES NOT TURN OFF

Description

INFOID:000000008280099

AWD warning lamp does not turn OFF several seconds after engine started.

Diagnosis Procedure

INFOID:000000008280100

1.PERFORM SELF-DIAGNOSIS

With CONSULT

Perform self-diagnosis for "ALL MODE AWD/4WD".

Is any error system detected?

YES >> Check the error system.

NO >> GO TO 2.

2.CHECK AWD WARNING LAMP

Perform the trouble diagnosis of the AWD warning lamp. Refer to [DLN-30, "Diagnosis Procedure"](#).

Is the inspection result normal?

YES-1 (Without VDC)>>GO TO 3.

YES-2 (With VDC)>> GO TO 4.

NO >> Repair or replace the malfunctioning part.

3.CHECK AWD CONTROL UNIT POWER SUPPLY AND GROUND CIRCUIT

Perform the trouble diagnosis of the power supply and ground circuit. Refer to [DLN-26, "Diagnosis Procedure"](#).

Is the inspection result normal?

YES >> Check each harness connector pin terminal for malfunction or disconnection.

NO >> Repair or replace the malfunctioning part.

4.CHECK ABS ACTUATOR AND ELECTRIC UNIT (CONTROL UNIT) POWER SUPPLY AND GROUND CIRCUIT

Perform the trouble diagnosis of the power supply and ground circuit. Refer to [BRC-107, "Diagnosis Procedure"](#).

Is the inspection result normal?

YES >> Check each harness connector pin terminal for malfunction or disconnection.

NO >> Repair or replace the malfunctioning part.

A
B
C
DLN
E
F
G
H
I
J
K
L
M
N
O
P

HEAVY TIGHT-CORNER BRAKING SYMPTOM OCCURS

< SYMPTOM DIAGNOSIS >

[TRANSFER: TY30A]

HEAVY TIGHT-CORNER BRAKING SYMPTOM OCCURS

Description

INFOID:000000008280101

Heavy tight-corner braking symptom occurs when the vehicle is driven and the steering wheel is turned fully to either side after the engine is started.

NOTE:

Light tight-corner braking symptom may occur depending on driving conditions. This is not malfunction.

Diagnosis Procedure

INFOID:000000008280102

1. PERFORM ECM SELF-DIAGNOSIS

With CONSULT

Perform self-diagnosis for "ENGINE".

Is any error system detected?

YES >> Check the error system.

NO >> GO TO 2.

2. PERFORM SELF-DIAGNOSIS

With CONSULT

Perform self-diagnosis for "ALL MODE AWD/4WD".

Is DTC "U1000" detected?

YES >> CAN specification chart. Refer to [LAN-16, "Trouble Diagnosis Flow Chart"](#).

NO-1 (With VDC)>>GO TO 3.

NO-2 (Without VDC)>>GO TO 4.

3. PERFORM SELF-DIAGNOSIS

With CONSULT

Perform self-diagnosis for "ALL MODE AWD/4WD".

Is DTC "C1211" or "C1212" detected?

YES >> Proceed to diagnosis procedure. Refer to [DLN-20, "Diagnosis Procedure"](#) (DTC "C1211") or [DLN-22, "Diagnosis Procedure"](#) (DTC "C1212").

NO >> GO TO 4.

4. CHECK AWD SOLENOID

Perform the trouble diagnosis of the AWD solenoid. Refer to [DLN-14, "Diagnosis Procedure"](#).

Is the inspection result normal?

YES >> GO TO 5.

NO >> Repair or replace the malfunctioning part.

5. CHECK ELECTRIC CONTROLLED COUPLING

1. Turn the ignition switch OFF.
2. Set the transaxle to neutral. Release the parking brake.
3. Lift up the vehicle.
4. Rotate the propeller shaft by hand.
5. Hold rear wheel of right and left lightly.

Does rear wheel rotate?

YES >> Replace electric controlled coupling for mechanical malfunction (clutch sticking etc.). Refer to [DLN-100, "Exploded View"](#).

NO >> Check each harness connector pin terminal for disconnection.

VEHICLE DOES NOT ENTER AWD MODE

< SYMPTOM DIAGNOSIS >

[TRANSFER: TY30A]

VEHICLE DOES NOT ENTER AWD MODE

Description

INFOID:000000008280103

Vehicle does not enter 4-wheel drive mode even though AWD warning lamp turned to OFF.

Diagnosis Procedure

INFOID:000000008280104

1. CHECK AWD WARNING LAMP

Turn the ignition switch ON.

Does AWD warning lamp turn ON?

YES >> GO TO 2.

NO >> Proceed to [DLN-30, "Diagnosis Procedure"](#).

2. CHECK PARKING BRAKE SWITCH SIGNAL

With CONSULT

Check "P BRAKE SW" of CONSULT- "DATA MONITOR" for "ALL MODE AWD/4WD".

Monitor Item	Condition	Status
P BRAKE SW	When the parking brake pedal is operation.	ON
	When the parking brake pedal is not operation.	OFF

Is the inspection result normal?

YES >> GO TO 3.

NO >> Proceed to diagnosis procedure. Refer to [BRC-151, "Diagnosis Procedure"](#) (with VDC), [BRC-50, "Diagnosis Procedure"](#) (without VDC).

3. CRUISE TEST

Drive the vehicle for a period of time.

Does any symptom occur?

YES >> Replace electric controlled coupling for mechanical malfunction (mechanical engagement of clutch is not possible). Refer to [DLN-100, "Exploded View"](#).

NO >> Check each harness connector pin terminal for disconnection.

A
B
C
DLN
E
F
G
H
I
J
K
L
M
N
O
P

AWD WARNING LAMP BLINKS QUICKLY

< SYMPTOM DIAGNOSIS >

[TRANSFER: TY30A]

AWD WARNING LAMP BLINKS QUICKLY

Description

INFOID:000000008280105

While driving, AWD warning lamp blinks 2 times in 1 second and it turns OFF after 1 minute.

- This symptom protects drivetrain parts when a heavy load is applied to the electric controlled coupling and multiple disc clutch temperature increases. Also, optional distribution of torque sometimes becomes rigid before lamp blinks quickly. Both cases are not malfunction.
- When this symptom occurs, stop vehicle and allow it to idle for some times. Blinking will stop and system will be restored.

AWD WARNING LAMP BLINKS SLOWLY

< SYMPTOM DIAGNOSIS >

[TRANSFER: TY30A]

AWD WARNING LAMP BLINKS SLOWLY

Description

INFOID:000000008280106

AWD warning lamp blinks at approximately 2 seconds intervals while driving.

Diagnosis Procedure

INFOID:000000008280107

1.CHECK TIRE

Check the following.

- Tire pressure
- Wear condition
- Front and rear tire size (There is no difference between front and rear tires.)

Is the inspection result normal?

YES >> GO TO 2.

NO >> Repair or replace damaged parts. And then, drive the vehicle at speed of 20 km/h (12 MPH) or more for 5 seconds or more. Improper size information is initialized accordingly.

2.CHECK INPUT SIGNAL OF TIRE DIAMETER

 **With CONSULT**

1. Start engine.
2. Drive at 20 km/h (12 MPH) or more for approx. 200 seconds.
3. Check "DIS-TIRE MONI" of "DATA MONITOR" for "ALL MODE AWD/4WD".

Does the item on "DATA MONITOR" indicate "0 - 4 mm"?

YES >> INSPECTION END

NO >> GO TO 3.

3.TERMINAL INSPECTION

Check AWD control unit harness connector (without VDC) or ABS actuator and electric unit (control unit) harness connector (with VDC) for disconnection.

Is the inspection result normal?

YES-1 (Without VDC)>>Replace AWD control unit. Refer to [DLN-55, "Exploded View"](#).

YES-2 (With VDC)>>Replace ABS actuator and electric unit (control unit). Refer to [BRC-180, "Exploded View"](#)

NO >> Repair or replace the malfunctioning part.

A
B
C
DLN
E
F
G
H
I
J
K
L
M
N
O
P

NORMAL OPERATING CONDITION

< SYMPTOM DIAGNOSIS >

[TRANSFER: TY30A]

NORMAL OPERATING CONDITION

Description

INFOID:000000008280108

While driving, AWD warning lamp blinks 2 times in 1 second and it turns OFF after 1 minute.

- This symptom protects drivetrain parts when a heavy load is applied to the electric controlled coupling and multiple disc clutch temperature increases. Also, optional distribution of torque sometimes becomes rigid before lamp blinks quickly. Both cases are not malfunction.
- When this symptom occurs, stop vehicle and allow it to idle for some times. Blinking will stop and system will be restored.

NOISE, VIBRATION AND HARSHNESS (NVH) TROUBLESHOOTING

< SYMPTOM DIAGNOSIS >

[TRANSFER: TY30A]

NOISE, VIBRATION AND HARSHNESS (NVH) TROUBLESHOOTING

NVH Troubleshooting Chart

INFOID:000000008280109

Use the chart below to find the cause of the symptom. The numbers indicate the order of the inspection. If necessary, repair or replace these parts.

Reference		DLN-54, "Inspection"			DLN-58, "Exploded View"		DLN-58, "Exploded View"		DLN-58, "Exploded View"		DLN-64, "Inspection After Disassembly"		DLN-64, "Inspection After Disassembly"	
SUSPECTED PARTS (Possible cause)		TRANSFER OIL (Level low)	TRANSFER OIL (Wrong)	TRANSFER OIL (Level too high)	LIQUID GASKET (Damaged)	O-RING (Worn or damaged)	OIL SEAL (Worn or damaged)	GEAR (Worn or damaged)	BEARING (Worn or damaged)					
Symptom	Noise	1	2				3	3	3					
	Transfer oil leakage		3	1	2	2	2							

A
B
C
DLN
E
F
G
H
I
J
K
L
M
N
O
P



PRECAUTION**PRECAUTIONS****FOR USA AND CANADA****FOR USA AND CANADA : Precaution for Supplemental Restraint System (SRS) "AIR BAG" and "SEAT BELT PRE-TENSIONER"**

INFOID:000000008280110

The Supplemental Restraint System such as "AIR BAG" and "SEAT BELT PRE-TENSIONER", used along with a front seat belt, helps to reduce the risk or severity of injury to the driver and front passenger for certain types of collision. This system includes seat belt switch inputs and dual stage front air bag modules. The SRS system uses the seat belt switches to determine the front air bag deployment, and may only deploy one front air bag, depending on the severity of a collision and whether the front occupants are belted or unbelted.

Information necessary to service the system safely is included in the "SRS AIR BAG" and "SEAT BELT" of this Service Manual.

WARNING:

Always observe the following items for preventing accidental activation.

- To avoid rendering the SRS inoperative, which could increase the risk of personal injury or death in the event of a collision that would result in air bag inflation, all maintenance must be performed by an authorized NISSAN/INFINITI dealer.
- Improper maintenance, including incorrect removal and installation of the SRS, can lead to personal injury caused by unintentional activation of the system. For removal of Spiral Cable and Air Bag Module, see "SRS AIR BAG".
- Never use electrical test equipment on any circuit related to the SRS unless instructed to in this Service Manual. SRS wiring harnesses can be identified by yellow and/or orange harnesses or harness connectors.

PRECAUTIONS WHEN USING POWER TOOLS (AIR OR ELECTRIC) AND HAMMERS**WARNING:**

Always observe the following items for preventing accidental activation.

- When working near the Air Bag Diagnosis Sensor Unit or other Air Bag System sensors with the ignition ON or engine running, never use air or electric power tools or strike near the sensor(s) with a hammer. Heavy vibration could activate the sensor(s) and deploy the air bag(s), possibly causing serious injury.
- When using air or electric power tools or hammers, always switch the ignition OFF, disconnect the battery, and wait at least 3 minutes before performing any service.

FOR USA AND CANADA : Service Notice or Precautions for Transfer

INFOID:000000008280111

CAUTION:

- After overhaul refill the transfer with new transfer oil.
- Check the oil level or replace the oil only with the vehicle parked on level surface.
- During removal or installation, keep inside of transfer clear of dust or dirt.
- Replace all tires at the same time. Always use tires of the proper size and the same brand and pattern. Fitting improper size and unusual wear tires applies excessive force to vehicle mechanism and can cause longitudinal vibration.
- Disassembly should be done in a clean work area.
- Before proceeding with disassembly, thoroughly clean the transfer. It is important to prevent the internal parts from becoming contaminated by dirt or other foreign matter.
- Check for the correct installation status prior to removal or disassembly. If matching marks are required, be certain they do not interfere with the function of the parts when applied.
- All parts should be carefully cleaned with a general purpose, non-flammable solvent before inspection or reassembly.
- Check appearance of the disassembled parts for damage, deformation, and unusual wear. Replace them with a new one if necessary.
- Gaskets, seals, O-rings and lock nuts should be replaced any time when the transfer is disassembled.
- In principle, tighten bolts or nuts gradually in several steps working diagonally from inside to outside. If tightening sequence is specified, use it.
- Observe the specified torque when assembling.

PRECAUTIONS

[TRANSFER: TY30A]

< PRECAUTION >

- Clean and flush the parts sufficiently and blow-dry them.
- Never damage sliding surfaces and mating surfaces.
- Use lint-free cloth or towels for wiping parts clean. Common shop rags can leave fibers that could interfere with the operation of the transfer.

FOR MEXICO

FOR MEXICO : Precaution for Supplemental Restraint System (SRS) "AIR BAG" and "SEAT BELT PRE-TENSIONER"

INFOID:000000008280112

The Supplemental Restraint System such as "AIR BAG" and "SEAT BELT PRE-TENSIONER", used along with a front seat belt, helps to reduce the risk or severity of injury to the driver and front passenger for certain types of collision. Information necessary to service the system safely is included in the "SRS AIR BAG" and "SEAT BELT" of this Service Manual.

WARNING:

Always observe the following items for preventing accidental activation.

- To avoid rendering the SRS inoperative, which could increase the risk of personal injury or death in the event of a collision that would result in air bag inflation, all maintenance must be performed by an authorized NISSAN/INFINITI dealer.
- Improper maintenance, including incorrect removal and installation of the SRS, can lead to personal injury caused by unintentional activation of the system. For removal of Spiral Cable and Air Bag Module, see "SRS AIR BAG".
- Never use electrical test equipment on any circuit related to the SRS unless instructed to in this Service Manual. SRS wiring harnesses can be identified by yellow and/or orange harnesses or harness connectors.

PRECAUTIONS WHEN USING POWER TOOLS (AIR OR ELECTRIC) AND HAMMERS

WARNING:

Always observe the following items for preventing accidental activation.

- When working near the Air Bag Diagnosis Sensor Unit or other Air Bag System sensors with the ignition ON or engine running, never use air or electric power tools or strike near the sensor(s) with a hammer. Heavy vibration could activate the sensor(s) and deploy the air bag(s), possibly causing serious injury.
- When using air or electric power tools or hammers, always switch the ignition OFF, disconnect the battery, and wait at least 3 minutes before performing any service.

FOR MEXICO : Service Notice or Precautions for Transfer

INFOID:000000008280113

CAUTION:

- After overhaul refill the transfer with new transfer oil.
- Check the oil level or replace the oil only with the vehicle parked on level surface.
- During removal or installation, keep inside of transfer clear of dust or dirt.
- Replace all tires at the same time. Always use tires of the proper size and the same brand and pattern. Fitting improper size and unusual wear tires applies excessive force to vehicle mechanism and can cause longitudinal vibration.
- Disassembly should be done in a clean work area.
- Before proceeding with disassembly, thoroughly clean the transfer. It is important to prevent the internal parts from becoming contaminated by dirt or other foreign matter.
- Check for the correct installation status prior to removal or disassembly. If matching marks are required, be certain they do not interfere with the function of the parts when applied.
- All parts should be carefully cleaned with a general purpose, non-flammable solvent before inspection or reassembly.
- Check appearance of the disassembled parts for damage, deformation, and unusual wear. Replace them with a new one if necessary.
- Gaskets, seals, O-rings and lock nuts should be replaced any time when the transfer is disassembled.
- In principle, tighten bolts or nuts gradually in several steps working diagonally from inside to outside. If tightening sequence is specified, use it.
- Observe the specified torque when assembling.
- Clean and flush the parts sufficiently and blow-dry them.
- Never damage sliding surfaces and mating surfaces.

PRECAUTIONS

< PRECAUTION >

[TRANSFER: TY30A]

-
- Use lint-free cloth or towels for wiping parts clean. Common shop rags can leave fibers that could interfere with the operation of the transfer.

PREPARATION

< PREPARATION >

[TRANSFER: TY30A]

PREPARATION

PREPARATION

Special Service Tools

INFOID:000000008280114

The actual shapes of TechMate tools may differ from those of special service tools illustrated here.

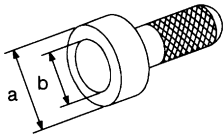
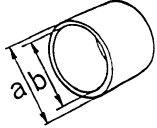
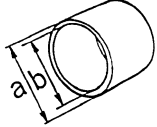
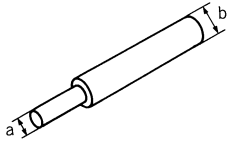
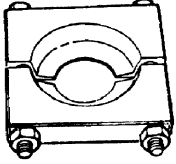
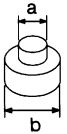
Tool number (TechMate No.) Tool name	Description
ST30720000 (J-25405) Drift a: 77 mm (3.03 in) dia. b: 55.5 mm (2.185 in) dia.	 <p style="text-align: center;">NT115</p> <ul style="list-style-type: none"> Installing adapter case oil seal Installing drive pinion oil seal
ST27861000 (—) Drift a: 62 mm (2.44 in) dia. b: 52 mm (2.05 in) dia.	 <p style="text-align: center;">ZZA1003D</p> <ul style="list-style-type: none"> Installing adapter case oil seal Installing drive pinion oil seal Installing inner race of ring gear shaft bearing (adapter case side)
KV40104830 (—) Drift a: 70 mm (2.76 in) dia. b: 63.5 mm (2.500 in) dia.	 <p style="text-align: center;">ZZA1003D</p> <p>Installing adapter case oil seal</p>
ST20610000 Drift (J-26366) a: 12 mm (0.47 in) dia. b: 18 mm (0.71 in) dia.	 <p style="text-align: center;">ZZA1178D</p> <p>Removing inner race of ring gear shaft bearing (transfer case side)</p>
ST22730000 (J-25681) Replacer	 <p style="text-align: center;">ZZA0700D</p> <ul style="list-style-type: none"> Removing inner race of ring gear shaft bearing (transfer case side) Removing inner race of drive pinion bearing (front side)
ST33052000 (—) Drift a: 22 mm (0.87 in) dia. b: 28 mm (1.10 in) dia.	 <p style="text-align: center;">NT116</p> <ul style="list-style-type: none"> Removing ring gear Removing inner race of drive pinion bearing (front side)

A

B

C

DLN

E

F

G

H

I

J

K

L

M

N

O

P

PREPARATION

< PREPARATION >

[TRANSFER: TY30A]

Tool number (TechMate No.) Tool name	Description
KV38104010 Drift (—) a: 49 mm (1.93 in) dia. b: 67 mm (2.64 in) dia.	Removing inner race of ring gear shaft bearing (adapter case side)
ST30621000 (J-35869) Drift a: 79 mm (3.11 in) dia. b: 59 mm (2.32 in) dia.	<ul style="list-style-type: none"> • Installing outer race of ring gear shaft bearing (adapter case side) • Installing outer race of drive pinion bearing (front side)
ST01530000 (—) Drift a: 48 mm (1.89 in) dia. b: 41 mm (1.61 in) dia.	Installing ring gear
ST35272000 (J-26092) Drift a: 72 mm (2.83 in) dia. b: 40 mm (1.57 in) dia. c: 35.5 mm (1.398 in) dia.	<ul style="list-style-type: none"> • Installing ring gear • Installing outer race of drive pinion bearing (front side)
KV10111400 (—) Drift a: 25 mm (0.98 in) dia. b: 20.8 mm (0.819 in) dia.	Installing inner race of ring gear shaft bearing (transfer case side)
KV381054S0 (—) Puller	Removing drive pinion oil seal
ST23860000 (—) Drift a: 38 mm (1.50 in) dia. b: 33 mm (1.30 in) dia.	Installing inner race of drive pinion bearing (front side)

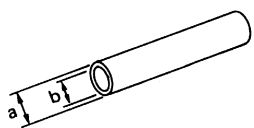
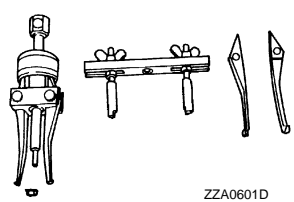
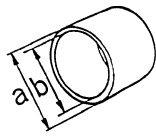
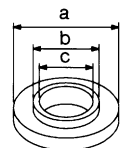
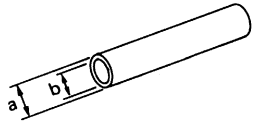
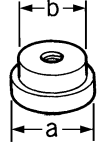
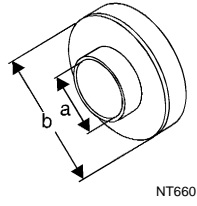

PREPARATION

< PREPARATION >

[TRANSFER: TY30A]

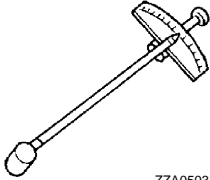
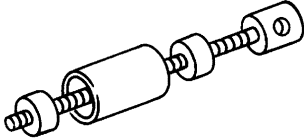
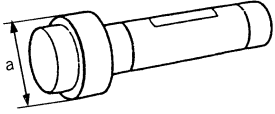
Tool number (TechMate No.) Tool name	Description	A
ST3127S000 (J-25765-A) Preload gauge <div style="text-align: center;">  <p>ZZA0503D</p> </div>	Measuring preload torque	B C
ST38280000 (J-38198) Bushing remover <div style="text-align: center;">  <p>NT685</p> </div>	Installing outer race of drive pinion bearing (front side)	DLN E F
ST33230000 (J-35867) Drift a: 51 mm (2.01 in) dia. <div style="text-align: center;">  <p>ZZA0938D</p> </div>	Installing outer race of drive pinion bearing (rear side)	G H

DLN

PERIODIC MAINTENANCE

TRANSFER OIL

Inspection

INFOID:000000008280115

OIL LEAKAGE

Check transfer surrounding area (oil seal, drain plug, filler plug, and transfer case, etc.) for oil leakage.

OIL LEVEL

1. Remove filler plug (1) and gasket. Then check that oil is filled up (A) from mounting hole for the filler plug.
2. Before installing filler plug, set a new gasket. Install filler plug on transfer and tighten to the specified torque. Refer to [DLN-58, "Exploded View"](#).

CAUTION:

Never reuse gaskets.

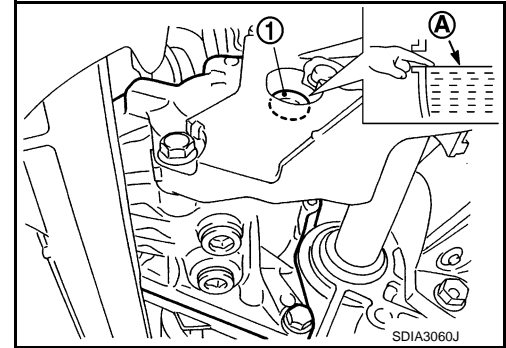

Draining

INFOID:000000008280116

1. Run the vehicle to warm up the transfer unit sufficiently.
2. Stop the engine and remove drain plug (1) and gaskets to drain the transfer oil.

CAUTION:

Never remove tooth contact test hole plug (2).

3. Before installing drain plug, set a new gasket. Install drain plug on transfer and tighten to the specified torque. Refer to [DLN-58, "Exploded View"](#).

CAUTION:

Never reuse gaskets.

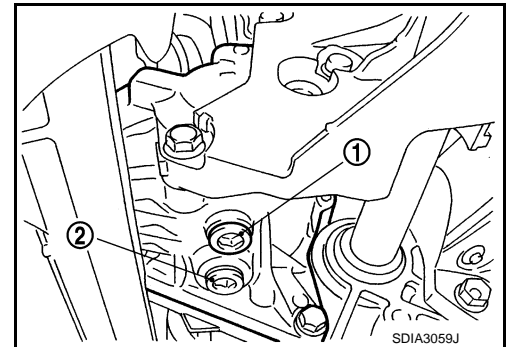

Refilling

INFOID:000000008280117

1. Remove filler plug (1) and gasket. Then fill oil up to mounting hole (A) for the filler plug.

Oil grade and viscosity

: Refer to [MA-15, "FOR NORTH AMERICA : Fluids and Lubricants"](#) (for NORTH AMERICA), [MA-16, "FOR MEXICO : Fluids and Lubricants"](#) (for MEXICO).

Oil capacity

: Refer to [DLN-81, "General Specifications"](#).

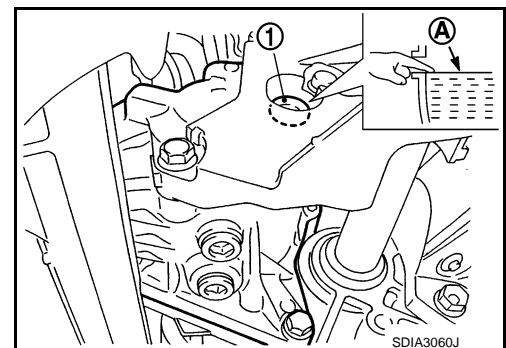

CAUTION:

Carefully fill the oil. (Fill up for approximately 3 minutes.)

2. Leave the vehicle for 3 minutes. Then check oil level again.
3. Before installing filler plug, set a new gasket. Install filler plug on transfer and tighten to the specified torque. Refer to [DLN-58, "Exploded View"](#).

CAUTION:

Never reuse gasket.

AWD CONTROL UNIT

< REMOVAL AND INSTALLATION >

[TRANSFER: TY30A]

REMOVAL AND INSTALLATION

AWD CONTROL UNIT

Exploded View

INFOID:000000008280118

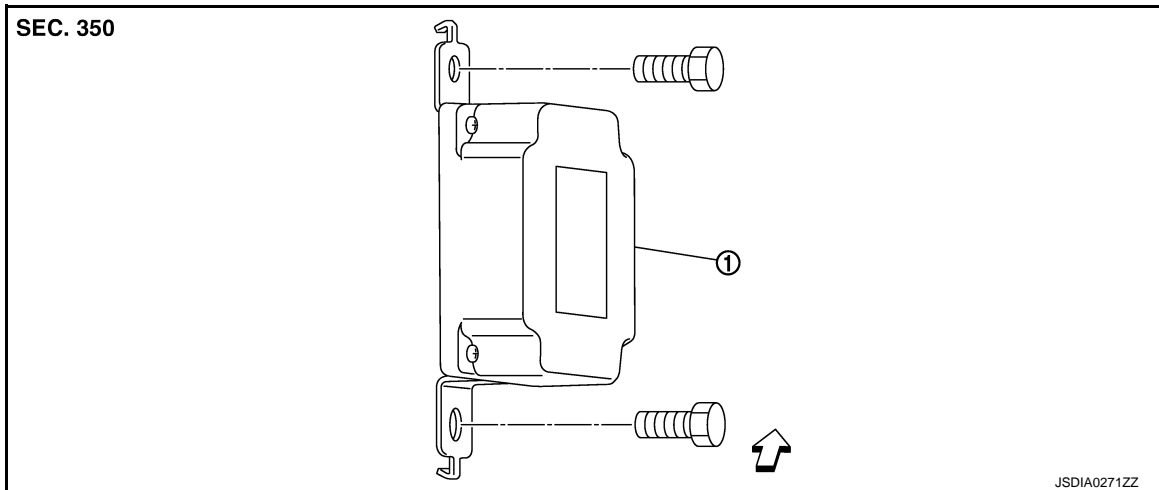

1. AWD control unit

←: Vehicle front

Removal and Installation

INFOID:000000008280119

REMOVAL

1. Remove the glove box cover assembly. Refer to [JP-13, "Exploded View"](#).
2. Disconnect AWD control unit harness connector.
3. Remove AWD control unit (1) mounting bolts.
4. Remove AWD control unit.

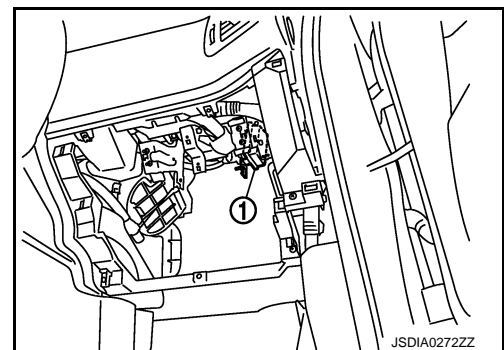

INSTALLATION

Install is the reverse order of removal.

UNIT REMOVAL AND INSTALLATION

TRANSFER ASSEMBLY

Exploded View

INFOID:000000008280120

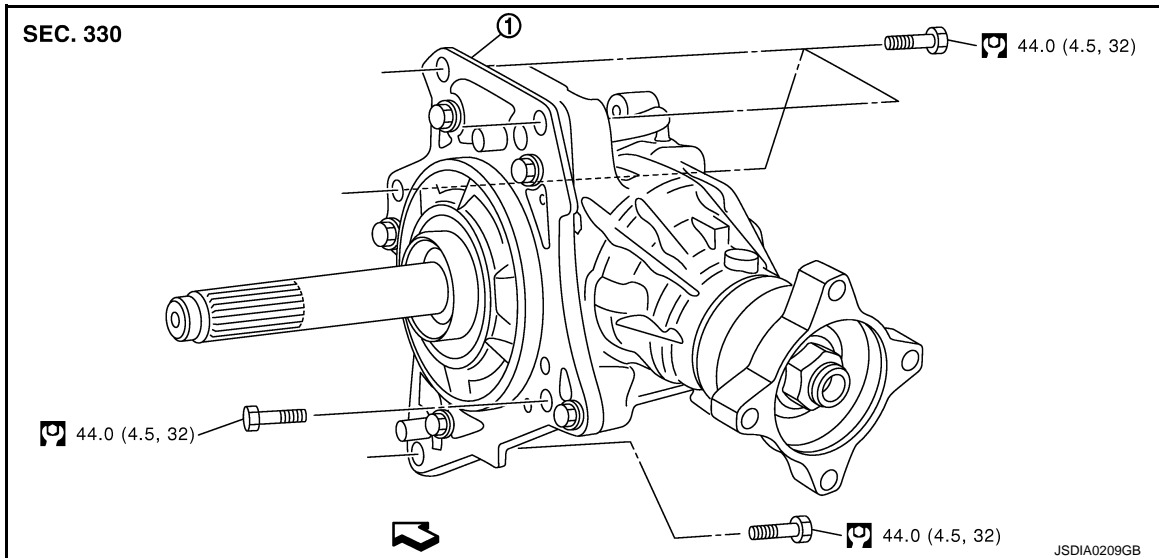

1. Transfer assembly

↔: Vehicle front

Refer to [GI-4, "Components"](#) for symbols in the figure.

Removal and Installation

INFOID:000000008280121

REMOVAL

1. Remove the exhaust front tube. Refer to [EX-4, "Exploded View"](#).
2. Remove the exhaust center tube. Refer to [EX-4, "Exploded View"](#).
3. Separate the rear propeller shaft. Refer to [DLN-85, "Exploded View"](#).
4. Remove right side drive shaft and support bearing bracket. Refer to [FAX-45, "Exploded View"](#).
5. Remove the mounting bolts (↔) of transaxle assembly and transfer assembly.

CAUTION:

Never remove the mounting bolts (↔) of adapter case.

6. Remove transfer assembly from the vehicle.

CAUTION:

- Never damage ring gear shaft.
- Never damage air breather hose.

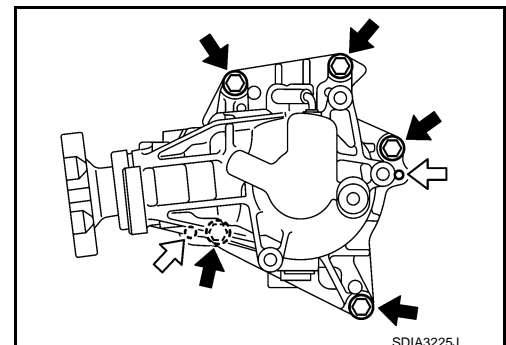

INSTALLATION

Note the following, and install in the reverse order of removal.

TRANSFER ASSEMBLY

< UNIT REMOVAL AND INSTALLATION >

[TRANSFER: TY30A]

- Install mounting bolts according to the standard below when installing transfer assembly to the transaxle assembly.

Bolt symbol	A	B
Installation direction	Transfer ⇒ Transaxle	Transaxle ⇒ Transfer

CAUTION:

- When installing transfer assembly to transaxle assembly, replace the side oil seal (transfer joint). Refer to [TM-199, "AWD : Exploded View"](#).
- Never damage side seal (the joint part of transfer) and dust cover of transaxle assembly.
- Check oil level and check for oil leakage after installation. Refer to [DLN-54, "Inspection"](#).

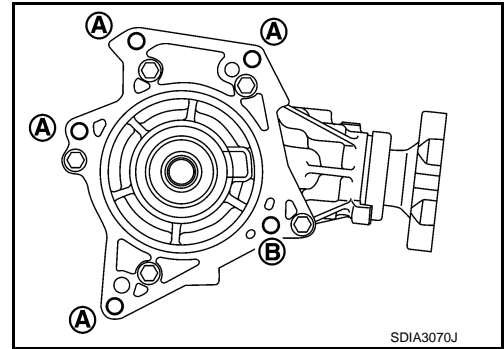

A
B
C

DLN

E
F
G
H
I
J
K
L
M
N
O
P

ADAPTER CASE

< UNIT DISASSEMBLY AND ASSEMBLY >

[TRANSFER: TY30A]

UNIT DISASSEMBLY AND ASSEMBLY

ADAPTER CASE

Exploded View

INFOID:000000008280122

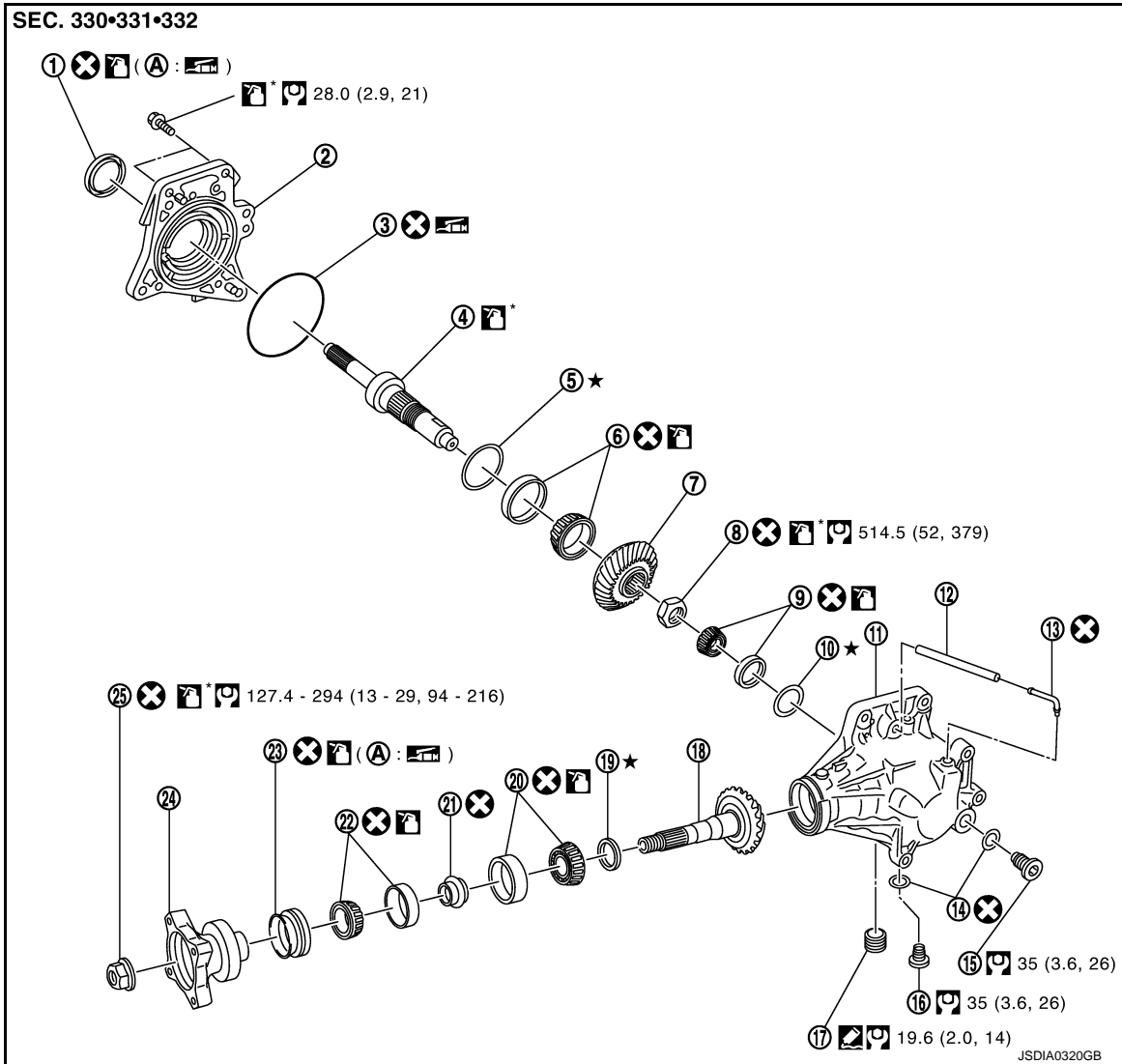



- | | | |
|---|---|---|
| 1. Adapter case oil seal | 2. Adapter case | 3. O-ring |
| 4. Ring gear shaft | 5. Ring gear adjusting shim (adapter case side) | 6. Ring gear shaft bearing (adapter case side) |
| 7. Ring gear | 8. Ring gear nut | 9. Ring gear shaft bearing (transfer case side) |
| 10. Ring gear adjusting shim (transfer case side) | 11. Transfer case | 12. Air breather hose |
| 13. Air breather tube | 14. Gasket | 15. Filler plug |
| 16. Drain plug | 17. Plug | 18. Drive pinion |
| 19. Drive pinion adjusting shim | 20. Drive pinion bearing (front side) | 21. Collapsible spacer |
| 22. Drive pinion bearing (rear side) | 23. Drive pinion oil seal | 24. Companion flange |
| 25. Lock nut | | |
- A: Oil seal lip

ADAPTER CASE

< UNIT DISASSEMBLY AND ASSEMBLY >

[TRANSFER: TY30A]

: Apply gear oil.

: Apply multi-purpose grease.

: Apply anti-corrosive oil.

: Apply Genuine Silicone RTV or equivalent. Refer to [GI-22, "Recommended Chemical Products and Sealants"](#).

Refer to [GI-4, "Components"](#) for symbols not described above.

Disassembly

INFOID:000000008280123

1. Remove adapter case mounting bolts (←).

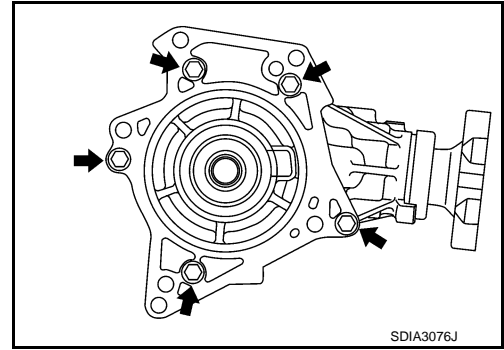

2. Lightly tap adapter case with a plastic hammer to remove adapter case.

3. Remove O-ring from adapter case.

CAUTION:

- Never use a tool.
- Never damage adapter case.

4. Lightly tap the metal part of adapter case oil seal with punch from back side of adapter case to remove adapter case oil seal.

CAUTION:

When removing oil seal, never damage adapter case by scooping it out with a tool.

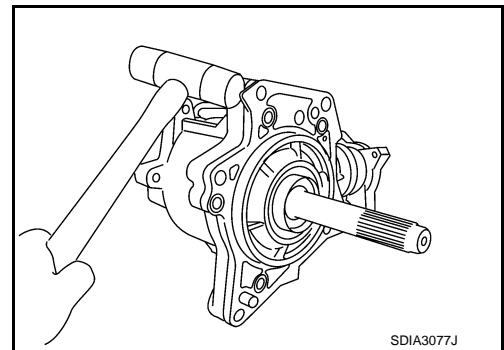

Assembly

INFOID:000000008280124

1. Install O-ring to adapter case.

CAUTION:

- Never reuse O-ring.
- When installing O-ring, never use a tool.
- Never damage adapter case.
- Apply multi-purpose grease to O-ring.

2. Install adapter case to the transfer case.

3. Apply anti-corrosive oil onto threads and seats of bolts (←), and tighten with the specified torque.

4. Check backlash, tooth contact, total preload and companion flange runout. Refer to [DLN-68, "Adjustment"](#).

CAUTION:

Measure the total preload without the adapter case oil seal.

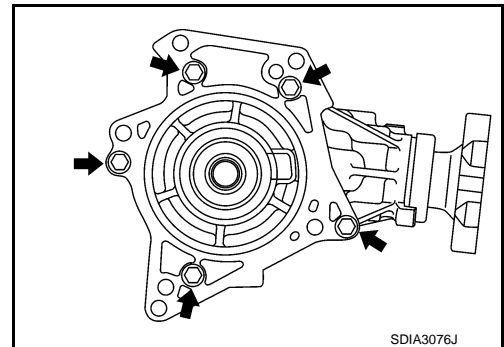

A

B

C

DLN

E

F

G

H

I

J

K

L

M

N

O

P

ADAPTER CASE

< UNIT DISASSEMBLY AND ASSEMBLY >

[TRANSFER: TY30A]

5. Install adapter case oil seal (1) to the adapter case with drifts.

A : Drift [SST: ST30720000 (J-25405)]

B : Drift [SST: ST27861000 (—)]

C : Drift [SST: KV40104830 (—)]

Dimension "D" : 0.5 – 1.5 mm (0.020 – 0.059 in)

CAUTION:

- **Never reuse adapter case oil seal.**
- **Apply multi-purpose grease onto oil seal lips, and gear oil onto the circumference.**

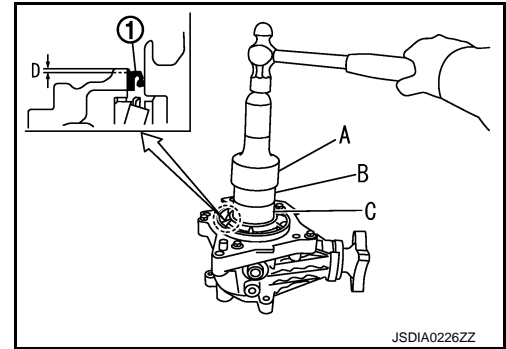

Inspection After Disassembly

INFOID:000000008280125

Check items below. If necessary, replace them with new ones.

CASE

Check the bearing mounting surface for wear, cracks and damages.

RING GEAR SHAFT

< UNIT DISASSEMBLY AND ASSEMBLY >

[TRANSFER: TY30A]

RING GEAR SHAFT

Exploded View

INFOID:000000008280126

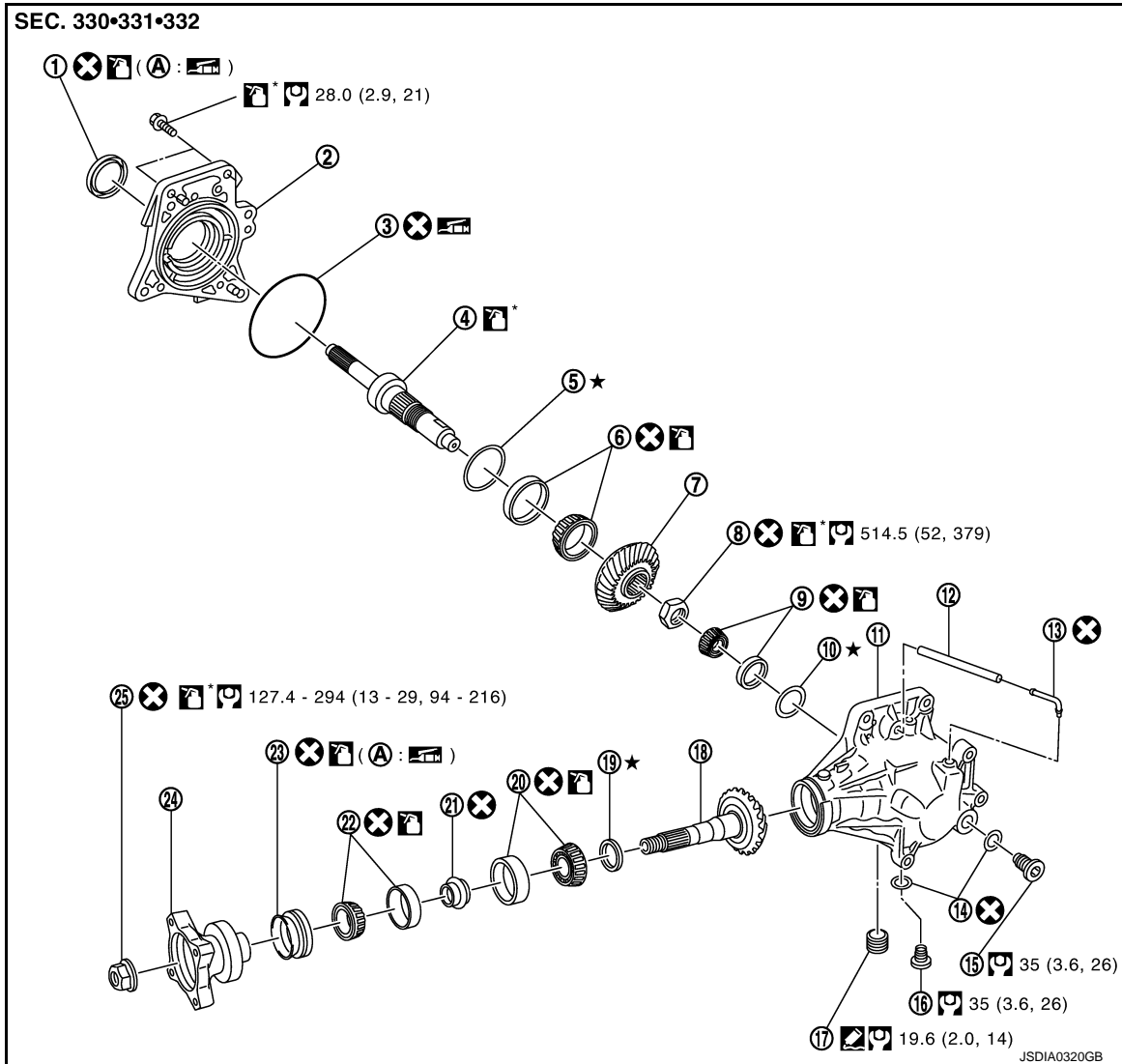

- | | | |
|---|---|---|
| 1. Adapter case oil seal | 2. Adapter case | 3. O-ring |
| 4. Ring gear shaft | 5. Ring gear adjusting shim (adapter case side) | 6. Ring gear shaft bearing (adapter case side) |
| 7. Ring gear | 8. Ring gear nut | 9. Ring gear shaft bearing (transfer case side) |
| 10. Ring gear adjusting shim (transfer case side) | 11. Transfer case | 12. Air breather hose |
| 13. Air breather tube | 14. Gasket | 15. Filler plug |
| 16. Drain plug | 17. Plug | 18. Drive pinion |
| 19. Drive pinion adjusting shim | 20. Drive pinion bearing (front side) | 21. Collapsible spacer |
| 22. Drive pinion bearing (rear side) | 23. Drive pinion oil seal | 24. Companion flange |
| 25. Lock nut | | |

A: Oil seal lip

: Apply gear oil.

: Apply multi-purpose grease.

A

B

C

DLN

E

F

G

H

I

J

K

L

M

N

O

P

RING GEAR SHAFT

< UNIT DISASSEMBLY AND ASSEMBLY >

[TRANSFER: TY30A]

 : Apply anti-corrosive oil.

 : Apply Genuine Silicone RTV or equivalent. Refer to [GI-22. "Recommended Chemical Products and Sealants"](#).
Refer to [GI-4. "Components"](#) for symbols not described above.

Disassembly

INFOID:000000008280127

1. Remove adapter case. Refer to [DLN-59. "Disassembly"](#).
2. Remove adapter case oil seal from the adapter case. Refer to [DLN-59. "Disassembly"](#).
3. Tap the ring gear adjusting shim from the cutout on the adapter case with a brass rod to remove ring gear shaft bearing outer race (adapter case side) and ring gear adjusting shim (adapter case side).

CAUTION:
Never damage adapter case.

4. Remove ring gear shaft assembly from the transfer case.
5. Remove outer race of ring gear shaft bearing (transfer case side) and ring gear adjusting shim (transfer case side) from the transfer case.
6. Remove inner race of ring gear shaft bearing (transfer case side) from ring gear shaft with drift (A) and replacer (B).

A : Drift [SST: ST20610000 (J-26366)]

B : Replacer [SST: ST22730000 (J-25681)]

7. Remove ring gear nut (1).

CAUTION:
Never damage ring gear shaft.

8. Remove ring gear from ring gear shaft with a drift (A) [SST: ST33052000 (—)].

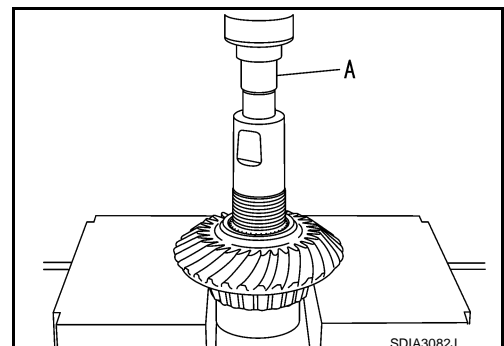
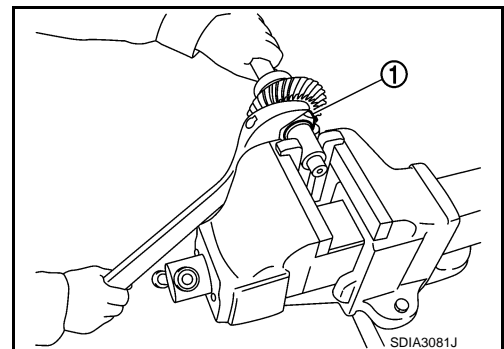
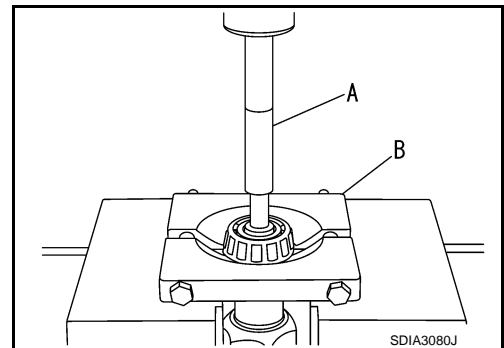
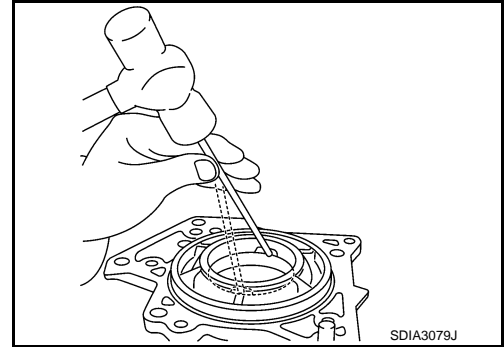

RING GEAR SHAFT

< UNIT DISASSEMBLY AND ASSEMBLY >

[TRANSFER: TY30A]

9. Remove inner race of ring gear shaft bearing (adapter case side) from ring gear with a drift (A) [SST: 38104010 (—)] and replacer.

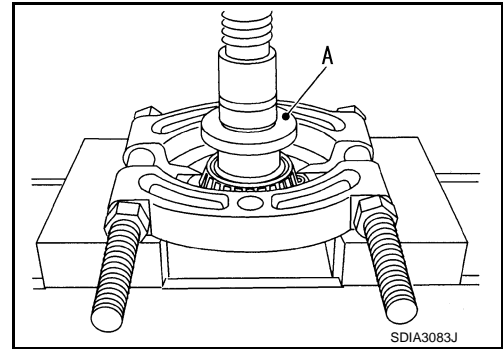

Assembly

INFOID:000000008280128

1. Select ring gear adjusting shim (transfer case side). Refer to [DLN-68, "Adjustment"](#).
2. Assemble the selected ring gear adjusting shim (transfer case side) and outer races of ring gear shaft bearing (transfer case side) to the transfer case.

CAUTION:

- Never reuse ring gear shaft bearing (transfer case side).
- Apply gear oil to the ring gear shaft bearing (transfer case side).

3. Select ring gear adjusting shim (adapter case side). Refer to [DLN-68, "Adjustment"](#).
4. Install the selected ring gear adjusting shim (adapter case side) to the adapter case.
5. Install outer race of ring gear shaft bearing (adapter case side) to the adapter case with a drift (A) [SST: ST30621000 (J-35869)].

CAUTION:

- Never reuse ring gear shaft bearing (adapter case side).
- Apply gear oil to the ring gear shaft bearing (adapter case side).

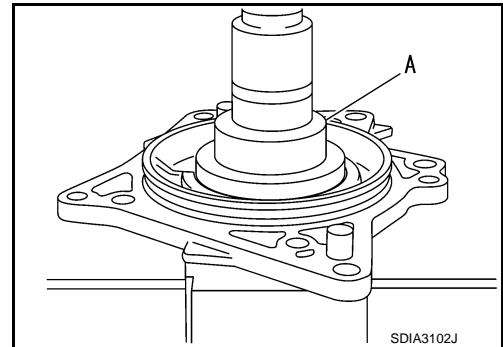

6. Install inner race of ring gear shaft bearing (adapter case side) to the ring gear with drifts.

A : Press adapter (If necessary)

B : Drift [SST: ST27861000 (—)]

CAUTION:

- Never reuse ring gear shaft bearing (adapter case side).
- Apply gear oil to the ring gear shaft bearing (adapter case side).

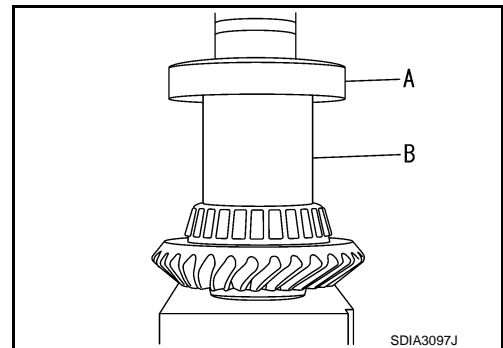

7. Apply anti-corrosive oil to the spline of ring gear shaft. Install the ring gear to ring gear shaft with drifts.

A : Drift [SST: ST01530000 (—)]

B : Drift [SST: ST35272000 (J-26092)]

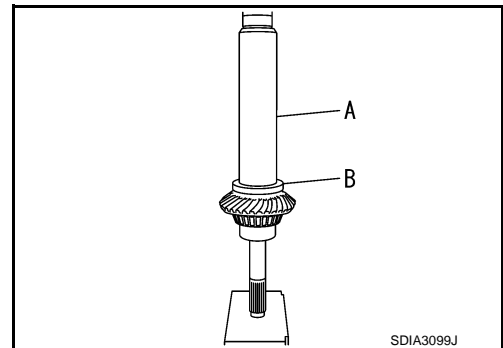

RING GEAR SHAFT

< UNIT DISASSEMBLY AND ASSEMBLY >

[TRANSFER: TY30A]

8. Apply anti-corrosive oil to threads and seats of ring gear nut. Tighten the ring gear nut with the specified torque by using a torque wrench.

CAUTION:

- Never reuse ring gear nut.
- Never damage ring gear shaft.

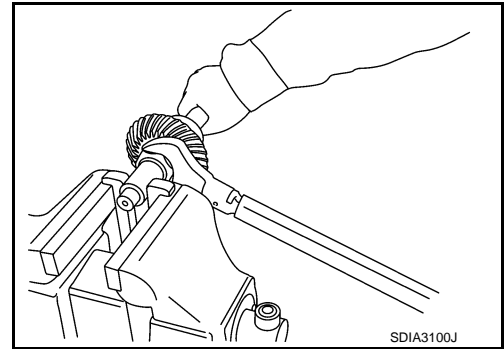

9. Install inner race of ring gear shaft bearing (transfer case side) to the ring gear shaft with a drift (A) [SST: KV10111400 (—)].

CAUTION:

- Never reuse ring gear shaft bearing (transfer case side).
- Apply gear oil to the ring gear shaft bearing (transfer race side).

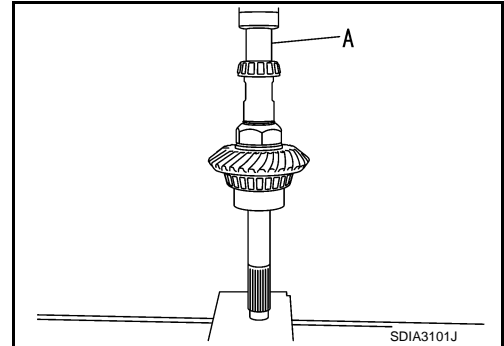

10. Assemble the ring gear shaft assembly to the transfer case.
11. Install adapter case. Refer to [DLN-59, "Assembly"](#).
12. Check backlash, tooth contact, total preload and companion flange runout. Refer to [DLN-68, "Adjustment"](#).

CAUTION:

Measure the total preload without the adapter case oil seal.

13. Install adapter case oil seal to the adapter case. Refer to [DLN-59, "Assembly"](#).

Inspection After Disassembly

INFOID:000000008280129

Check items below. If necessary, replace them with new ones.

GEAR AND SHAFT

Check gear face and shaft for wear, cracks, damage, and seizure.

CAUTION:

Replace ring gear and drive pinion as a set (hypoid gear set) if any malfunction is detected on the ring gear or drive pinion.

BEARING

Check for seizure, peeling, wear, corrosion, sticking, unusual noise, roughness in hand turning, and other damage.

CAUTION:

Always replace inner race and outer race as a pair when replacing the bearing.

SHIM

Check for seizure, damage, and unusual wear.

CASE

Check the bearing mounting surface for wear, cracks and damages.

DRIVE PINION

< UNIT DISASSEMBLY AND ASSEMBLY >

[TRANSFER: TY30A]

DRIVE PINION

Exploded View

INFOID:000000008280130

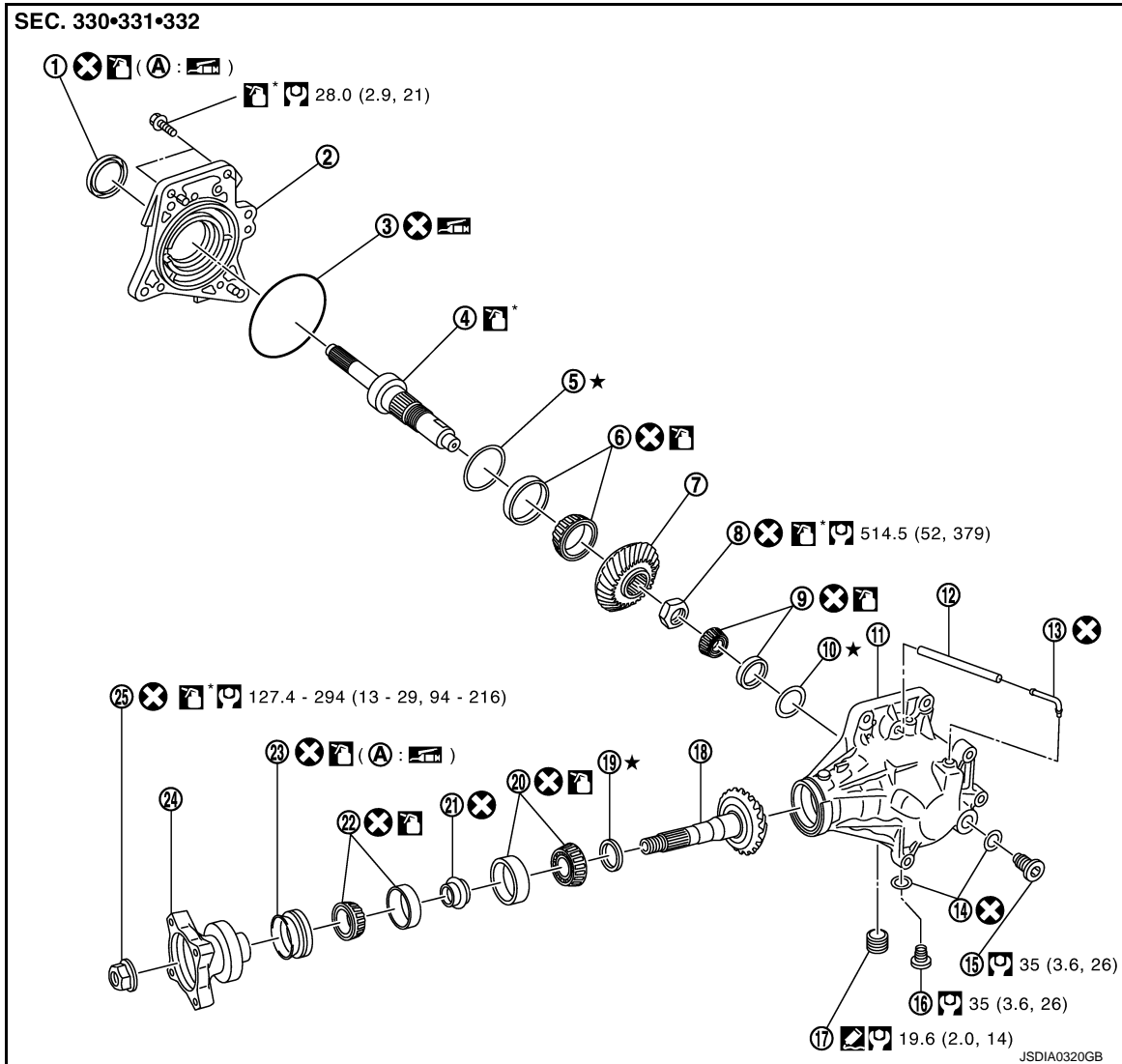

- | | | |
|---|---|---|
| 1. Adapter case oil seal | 2. Adapter case | 3. O-ring |
| 4. Ring gear shaft | 5. Ring gear adjusting shim (adapter case side) | 6. Ring gear shaft bearing (adapter case side) |
| 7. Ring gear | 8. Ring gear nut | 9. Ring gear shaft bearing (transfer case side) |
| 10. Ring gear adjusting shim (transfer case side) | 11. Transfer case | 12. Air breather hose |
| 13. Air breather tube | 14. Gasket | 15. Filler plug |
| 16. Drain plug | 17. Plug | 18. Drive pinion |
| 19. Drive pinion adjusting shim | 20. Drive pinion bearing (front side) | 21. Collapsible spacer |
| 22. Drive pinion bearing (rear side) | 23. Drive pinion oil seal | 24. Companion flange |

25. Lock nut
- A: Oil seal lip

: Apply gear oil.

: Apply multi-purpose grease.

A
B
C
DLN
E
F
G
H
I
J
K
L
M
N
O
P

DRIVE PINION

< UNIT DISASSEMBLY AND ASSEMBLY >

[TRANSFER: TY30A]

*: Apply anti-corrosive oil.

: Apply Genuine Silicone RTV or equivalent. Refer to [GI-22. "Recommended Chemical Products and Sealants"](#).
Refer to [GI-4. "Components"](#) for symbols not described above.

Disassembly

INFOID:00000008280131

1. Remove adapter case. Refer to [DLN-59. "Disassembly"](#).
2. Remove ring gear shaft assembly. Refer to [DLN-62. "Disassembly"](#).
3. Remove lock nut from the drive pinion.
4. Put matching marks (A) on screw ends of companion flange (1) and drive pinion.

CAUTION:

Use paint to avoid scratching the surface.

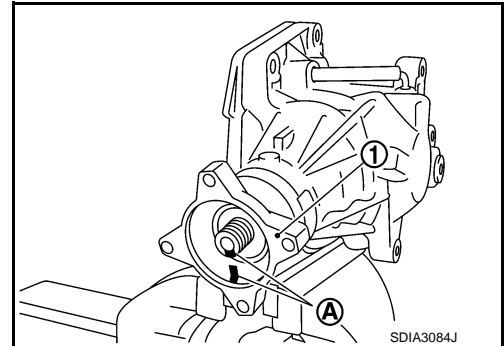

5. Remove companion flange from drive pinion with a puller.

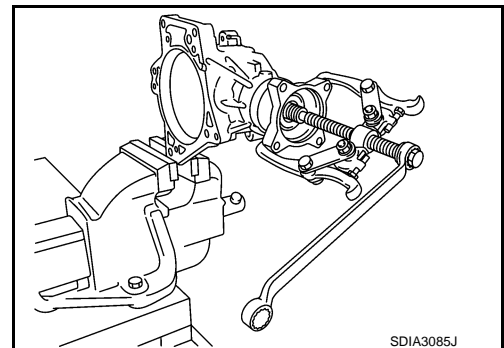

6. Remove drive pinion oil seal from the transfer case with a puller (A) [SST: KV381054S0 (—)].

CAUTION:

Never damage transfer case.

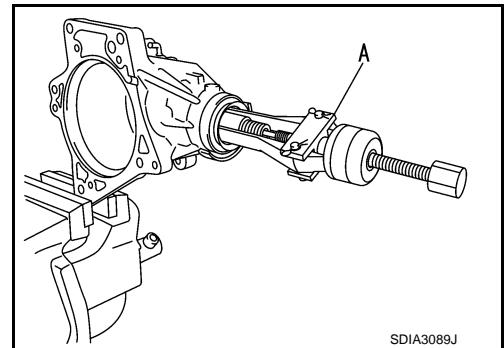

7. Remove drive pinion assembly from transfer case while tapping the drive pinion lightly with a plastic hammer.

CAUTION:

Never drop the drive pinion assembly.

8. Remove collapsible spacer from the drive pinion.
9. Remove inner race of drive pinion bearing (rear side) from transfer case.

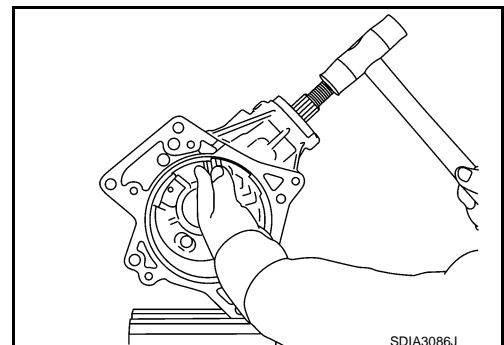

DRIVE PINION

< UNIT DISASSEMBLY AND ASSEMBLY >

[TRANSFER: TY30A]

10. Remove inner race of drive pinion bearing (front side) from drive pinion with a drift (A) and replacer (B).

A : Drift [SST:ST33052000 (—)]

B : Replacer [SST: 22730000 (J-25681)]

11. Remove drive pinion adjusting shim from the drive pinion.

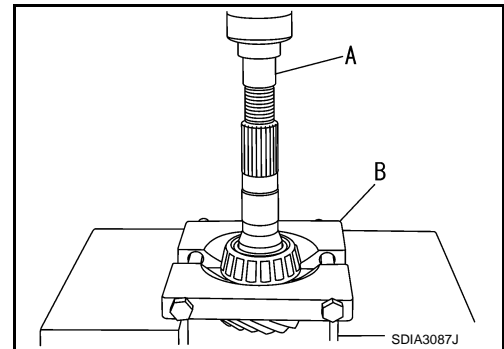

INFOID:000000008280132

Assembly

1. Select drive pinion adjusting shim. Refer to [DLN-68, "Adjustment"](#).
2. Install selected drive pinion adjusting shim to drive pinion.
3. Install inner race of drive pinion bearing (front side) to drive pinion with a drift (A) [SST: ST23860000 (—)].

CAUTION:

- Never reuse drive pinion bearing (front side).
- Apply gear oil to the drive pinion bearing (front side).

4. Assemble the inner race of drive pinion bearing (rear side) into the transfer case.

CAUTION:

- Never reuse drive pinion bearing (rear side).
- Apply gear oil to the drive pinion bearing (rear side).

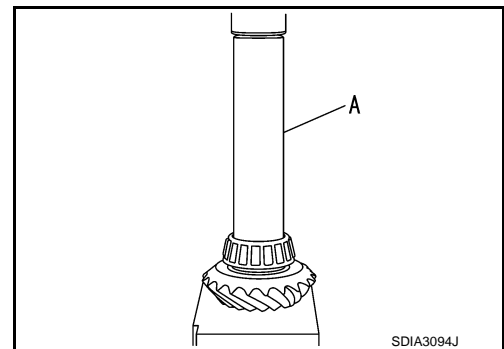

5. Install drive pinion oil seal to transfer case with drifts so that it becomes flush with case end surface.

A : Drift [SST: ST27861000 (—)]

B : Drift [SST: ST30720000 (J-25405)]

CAUTION:

- Never reuse oil seal.
- Apply multi-purpose grease onto oil seal lips, and gear oil onto the circumference.

6. Assemble a collapsible spacer onto the drive pinion.

CAUTION:

Never reuse the collapsible spacer.

7. Assemble drive pinion assembly into the transfer case, and then install companion flange (1) to drive pinion.

NOTE:

Align matching marks (A) on the thread edge of companion flange and drive pinion and install companion flange if drive pinion is reused.

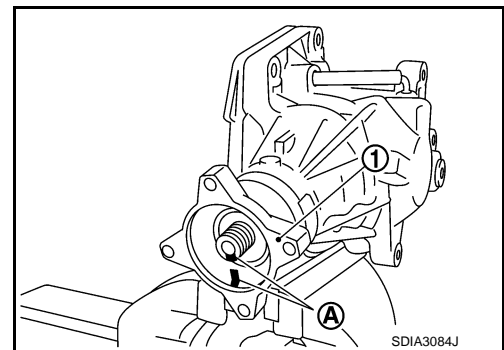
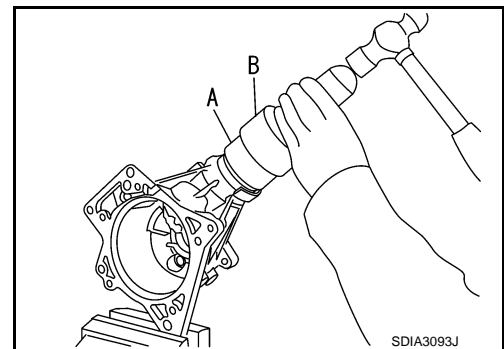

A
B
C
DLN
E
F
G
H
I
J
K
L
M
N
O
P

DRIVE PINION

< UNIT DISASSEMBLY AND ASSEMBLY >

[TRANSFER: TY30A]

- Tap the companion flange with a plastic hammer as far as the lock nut can be tightened.

CAUTION:

Never damage drive pinion oil seal.

- Apply anti-corrosive oil to the thread and seat of the lock nut, and temporarily tighten lock nut to the drive pinion.

CAUTION:

Never reuse lock nut.

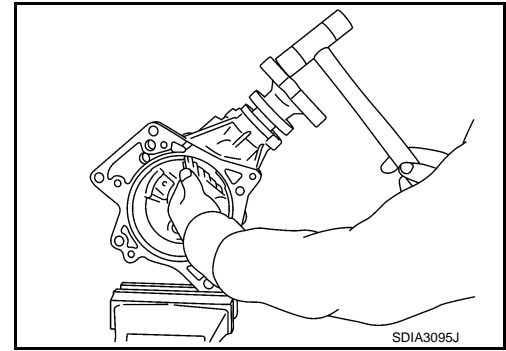

- Tighten lock nut within the specified torque range with a preload gauge (A) [SST: ST3127S000 (—)] so that the drive pinion bearing preload is within standard.

Standard

Drive pinion bearing preload : Refer to [DLN-81, "Pre-load Torque"](#).

CAUTION:

- Start the tightening of lock nut from lower limit of the specified torque. Check the preload every 5° to 10° while tightening the lock nut.
- Replace the collapsible spacer and tighten it again to adjust if preload exceeds the specified value. Never loosen lock nut to adjust preload.
- After adjustment, rotate the drive pinion back and forth from 2 to 3 times to check for unusual noise, sticking, binding, and so on.

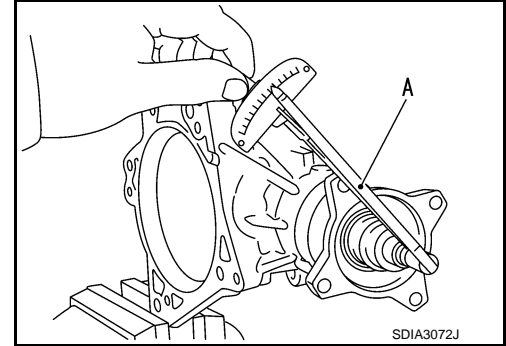

- Install ring gear shaft assembly. Refer to [DLN-63, "Assembly"](#).

- Install adapter case. Refer to [DLN-59, "Assembly"](#).

- Check backlash, tooth contact, total preload and companion flange runout. Refer to [DLN-68, "Adjustment"](#).

CAUTION:

Measure the total preload without the adapter case oil seal.

Adjustment

INFOID:000000008280133

BACKLASH

- Install the bolt (A) to the companion flange.
- Fit a dial indicator onto the bolt.
- Measure the circumference backlash of the companion flange.

Standard

Backlash : Refer to [DLN-81, "Backlash"](#).

Disassemble the transfer assembly to check and adjust each part if it is outside the standard.

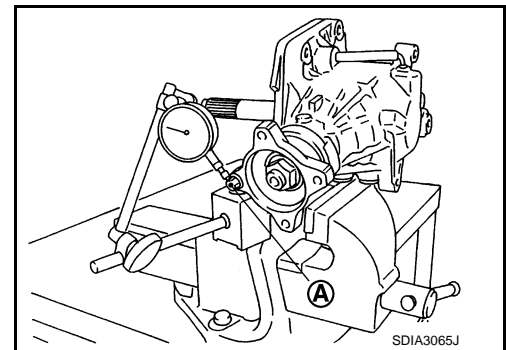

TOOTH CONTACT

- Remove adapter case. Refer to [DLN-59, "Disassembly"](#).

DRIVE PINION

< UNIT DISASSEMBLY AND ASSEMBLY >

[TRANSFER: TY30A]

- Remove ring gear shaft assembly from transfer case. Then apply red lead onto the ring gear.

CAUTION:

Apply red lead to both faces of 3 to 4 gears at 4 locations evenly spaced on the ring gear.

- Assemble the ring gear shaft assembly to the transfer case.
- Install adapter case. Refer to [DLN-59. "Assembly"](#).
- Remove plug on the lower side of the transfer case.

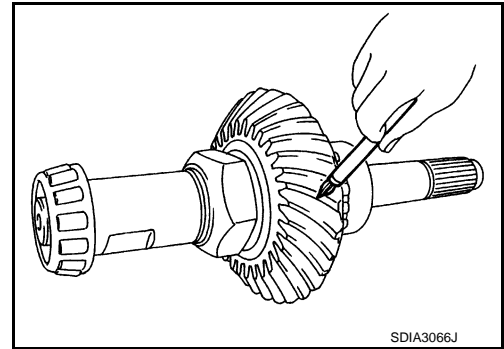

- Rotate the companion flange back and forth several times. Then check drive pinion to ring gear tooth contact by viewing from the tooth contact test hole. (A: Drive side, B: Reverse side)

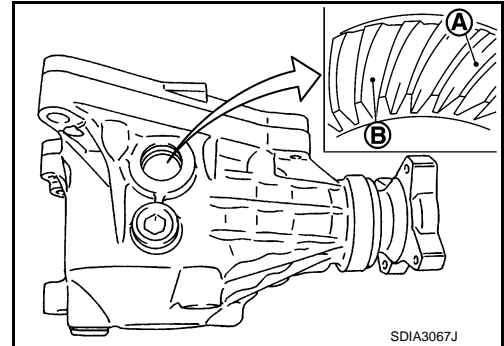

Tooth Contact Judgment Guide

Drive pinion adjusting shim selection value mm (in)		Tooth contact condition		Need for adjustment
		Drive side	Back	
↑ Thicker	+0.12 (+0.0047)	Heel side Toe side		Yes
	+0.09 (+0.0035)			
	+0.06 (+0.0024)			
	+0.03 (+0.0012)			
	0 (0.0)			
↓ Thinner	-0.03 (-0.0012)			Yes
	-0.06 (-0.0024)			
	-0.09 (-0.0035)			
	-0.12 (-0.0047)			

JSDIA0213GB

A
B
C
DLN
E
F
G
H
I
J
K
L
M
N
O
P

DRIVE PINION

< UNIT DISASSEMBLY AND ASSEMBLY >

[TRANSFER: TY30A]

7. Follow the procedure below to adjust pinion height (dimension X) if tooth contact is improper. For selecting adjusting shims, refer to the latest parts information.

CAUTION:

If no adjusting shim with the calculated value is available, select the thicker and closest one.

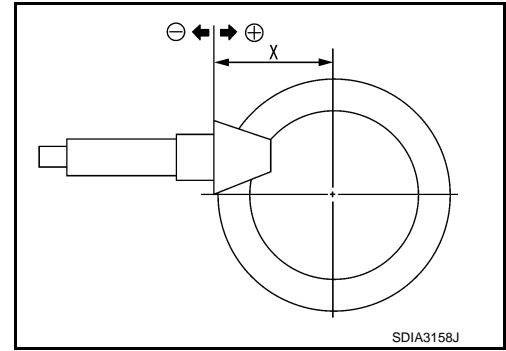

- Thicken the drive pinion adjusting shim to move the drive pinion closer to the ring gear in case of face contact or heel contact.

CAUTION:

Only one adjusting shim can be selected.

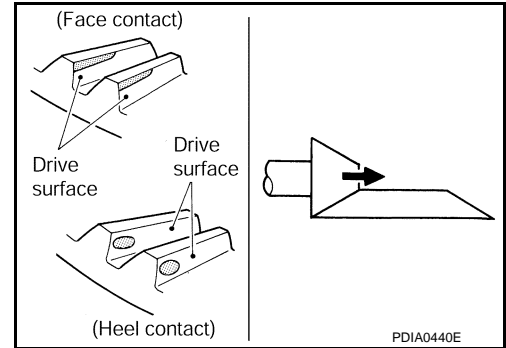

- Thin the drive pinion adjusting shim to move the drive pinion farther from the ring gear in case of flank contact or toe contact.

CAUTION:

Only one adjusting shim can be selected.

8. Assemble the plug to the transfer case.

CAUTION:

- Remove old gasket on mounting surface, then remove any moisture, oil, and foreign material on the application and mounting surfaces.
- Apply sealant to the thread, and tighten to the specified torque when installing plug.
- Use Genuine Silicone RTV or equivalent. Refer to [GI-22, "Recommended Chemical Products and Sealants"](#).

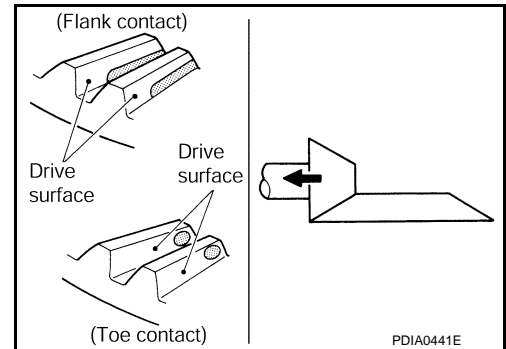

DRIVE PINION BEARING PRELOAD

1. Remove adapter case. Refer to [DLN-59, "Disassembly"](#).
2. Remove ring gear shaft assembly from the transfer case.
3. Rotate the companion flange back and forth from 2 to 3 times to check for unusual noise, binding, sticking, and so on.
4. Rotate the companion flange at least 20 times to check for smooth operation of the bearing.
5. Measure the drive pinion bearing preload with a preload gauge (A) [SST: ST3127S000 (—)].

Standard

Drive pinion bearing preload : Refer to [DLN-81, "Pre-load Torque"](#).

CAUTION:

Each rotational part should rotate smoothly with the specified gear oil.

- Disassemble the drive pinion assembly to check and adjust each part if outside the standard.

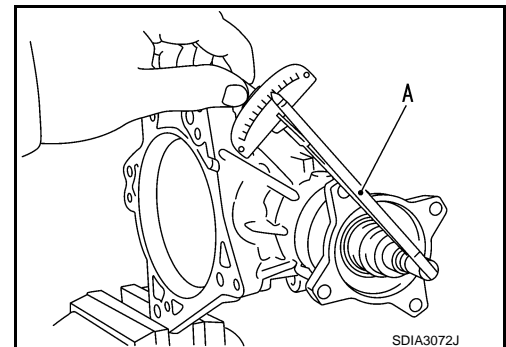

TOTAL PRELOAD

DRIVE PINION

< UNIT DISASSEMBLY AND ASSEMBLY >

[TRANSFER: TY30A]

1. Measure drive pinion bearing preload (P1). Refer to "DRIVE PINION BEARING PRELOAD".
CAUTION:
Check that the drive pinion bearing preload is within the standard.
2. Assemble the ring gear shaft assembly to the transfer case.
3. Install adapter case. Refer to [DLN-59, "Assembly"](#).
4. Rotate the companion flange at least 20 times to check for smooth operation of the bearing.
5. Measure the total preload with a preload gauge (A) [SST: ST3127S000 (—)].

Standard

Total preload

All oil seals are installed

: Refer to [DLN-81, "Preload Torque"](#).

Without adapter case oil seal

: Refer to [DLN-81, "Preload Torque"](#).

CAUTION:

- Each rotational part should rotate smoothly with the specified gear oil.
- Disassemble the transfer assembly to check and adjust each part if outside the standard. Measure it with the adapter case oil seals removed when measuring total preload after disassembly. Then install adapter case oil seals.

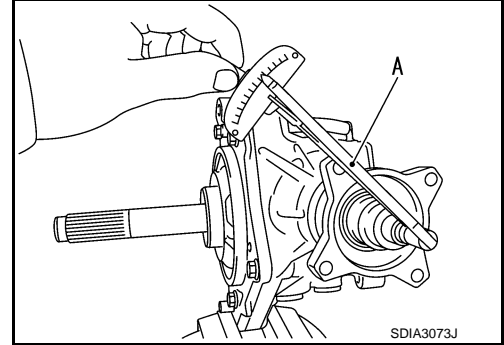

COMPANION FLANGE RUNOUT

1. Fit a dial indicator onto the companion flange face (inner side of the propeller shaft bolt holes).
2. Rotate the companion flange to check for runout.

Limit

Companion flange runout

: Refer to [DLN-81, "Companion Flange Runout"](#).

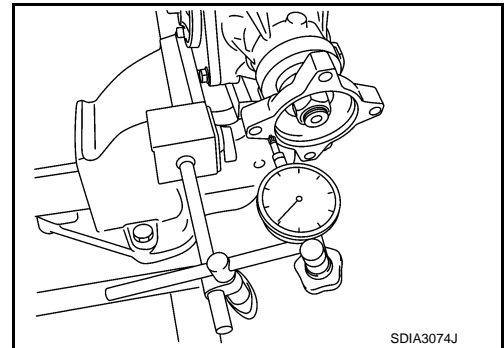

3. Fit a test indicator to the inner side of the companion flange (socket diameter).
4. Rotate the companion flange to check for runout.

Limit

Companion flange runout

: Refer to [DLN-81, "Companion Flange Runout"](#).

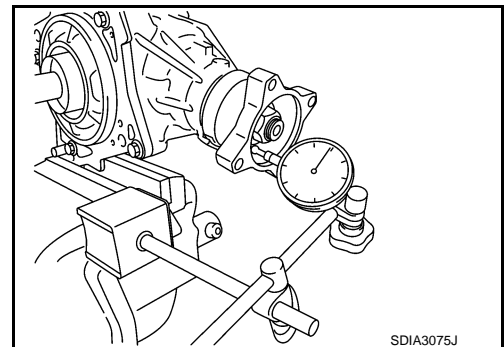

5. Follow the procedure below to adjust if runout value is outside the repair limit.

CAUTION:

Replace collapsible spacer to check and adjust each part when companion flange is adjusted or replaced.

- a. Check for runout while changing the phase between companion flange and drive pinion in 90° steps. Then search for the minimum point.
- b. Replace companion flange if runout value is still outside the limit after the phase has been changed.
- c. Adjust assembly status of the drive pinion bearings and drive pinion, or replace drive pinion bearings if runout is outside the standard after the companion flange is replaced.

ADJUSTING SHIM SELECTION

Measuring Point

A
B
C
DLN
E
F
G
H
I
J
K
L
M
N
O
P

DRIVE PINION

< UNIT DISASSEMBLY AND ASSEMBLY >

[TRANSFER: TY30A]

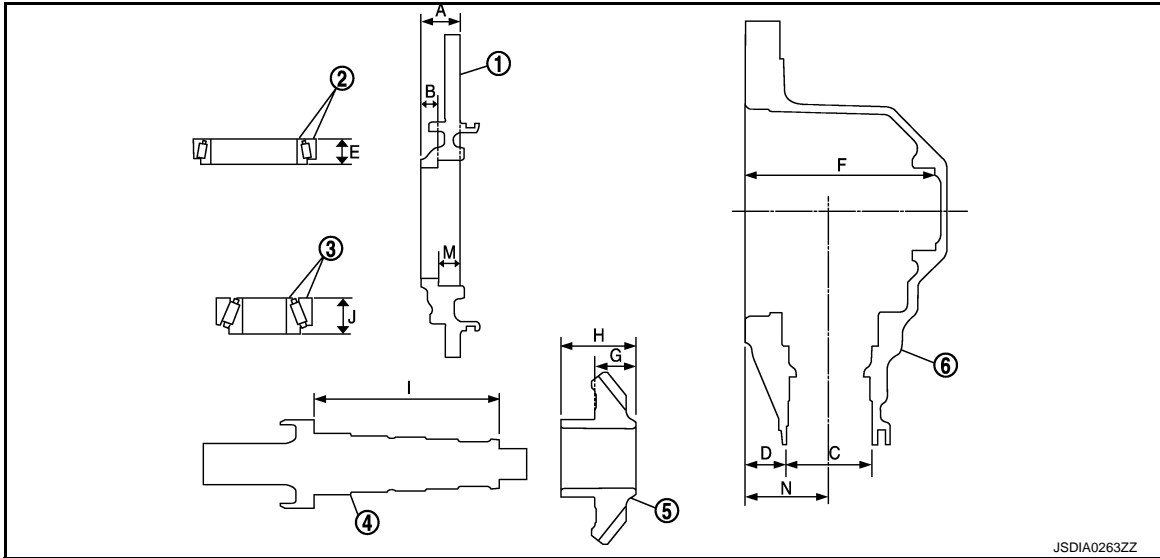

- | | | |
|--------------------|---|--|
| 1. Adapter case | 2. Ring gear shaft bearing
(Adapter case side) | 3. Ring gear shaft bearing
(Transfer case side) |
| 4. Ring gear shaft | 5. Ring gear | 6. Transfer case |

Ring Gear Adjusting Shim (Adapter Case Side)

1. Measure the dimensions of each measuring point with the following procedure:

Dimension "A" measurement

- Measure dimension from transfer case mounting surface of adapter case to adapter case edge surface with a pair of vernier calipers and straightedge. Refer to "Measuring point".

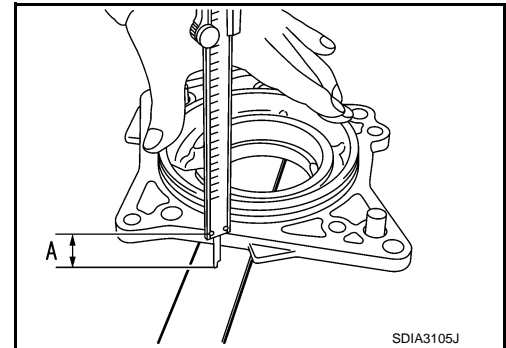

Dimension "B" measurement

- Measure dimension from ring gear adjusting shim mounting surface of adapter case to adapter case edge surface with a pair of vernier calipers and straightedge. Refer to "Measuring point".

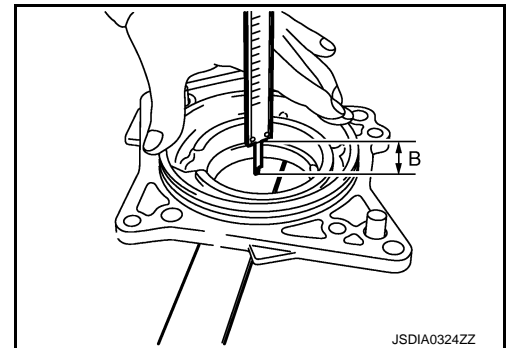

Dimension "C" measurement

DRIVE PINION

< UNIT DISASSEMBLY AND ASSEMBLY >

[TRANSFER: TY30A]

- Measure the diameter of drive pinion bearing (rear side) mounting area of transfer case with a pair of vernier calipers. Refer to “Measuring point”.

CAUTION:

Never damage transfer case.

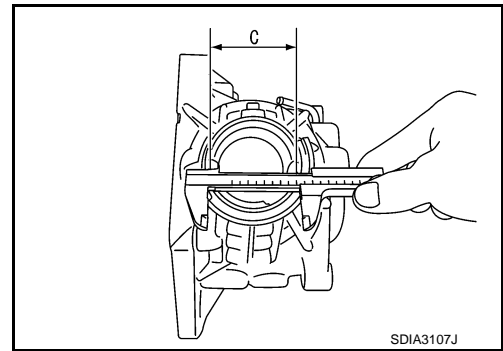

A

B

C

DLN

Dimension “D” measurement

- Measure dimension from adapter case mounting surface of transfer case to drive pinion bearing (rear side) mounting surface with a pair of vernier calipers and straightedge. Refer to “Measuring point”.

CAUTION:

- **Never damage transfer case.**
- **Consider the thickness of a straightedge.**

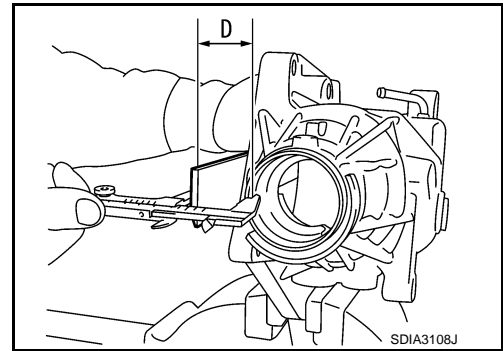

E

F

G

H

Dimension “E” measurement

- Measure dimension from outer race edge surface of ring gear shaft bearing (adapter case side) to inner race edge surface with a pair of vernier calipers. Refer to “Measuring point”.

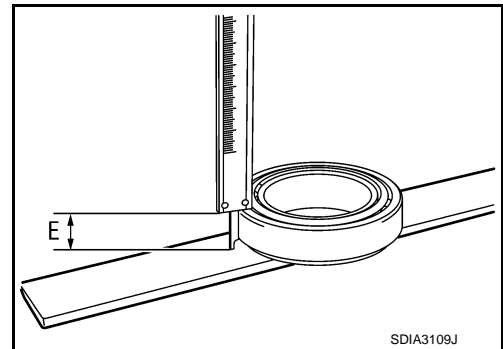

I

J

K

L

2. Calculate dimensions “M” and “N” by the formula below.

Dimension “M” = “A” – “B”

Dimension “N” = “C” × 0.5 mm (0.020 in) + “D”

3. Convert the dimensions “E”, “M” and “N” according to the standards below.

“E” : Decide actual value regarding 20.00 mm (0.7874 in) as 0 in increments of 0.01 mm (0.0004 in).

“M” : Decide actual value regarding 13.90 mm (0.5472 in) as 0 in increments of 0.01 mm (0.0004 in).

“N” : Decide actual value regarding 55.00 mm (2.1654 in) as 0 in increments of 0.01 mm (0.0004 in).

M

N

O

P

DRIVE PINION

< UNIT DISASSEMBLY AND ASSEMBLY >

[TRANSFER: TY30A]

4. Check dimension "Z" (machining difference) on the ring gear back surface.

NOTE:

Dimension "Z" indicates difference between optimum engagement and the standard dimensions in increments of 0.01 mm (0.0004 in) written on the ring gear back surface.

5. Calculate the thickness of the ring gear adjusting shim (adapter case side) "T₁" by the formula below.

$$\text{"T}_1\text{"} = (\text{"M"} + \text{"N"} - \text{"E"} - \text{"Z"}) \times 0.01 \text{ mm (0.0004 in)} + 1.40 \text{ mm (0.0551 in)}$$

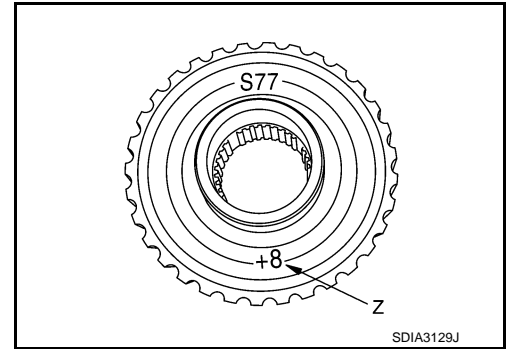

6. Select ring gear adjusting shim (adapter case side). For selecting adjusting shim, refer to the latest parts information.

CAUTION:

- Only one adjusting shim can be selected.
- Select the closest one, favoring thicker over thinner when necessary if no adjusting shim with the calculated value is available.

Ring Gear Adjusting Shim (Transfer Case Side)

1. Measure the dimensions of each measuring point with the following procedure:

Dimension "C" measurement

- Measure the diameter of drive pinion bearing (rear side) mounting area of transfer case with a pair of vernier calipers. Refer to "Measuring point".

CAUTION:

Never damage transfer case.

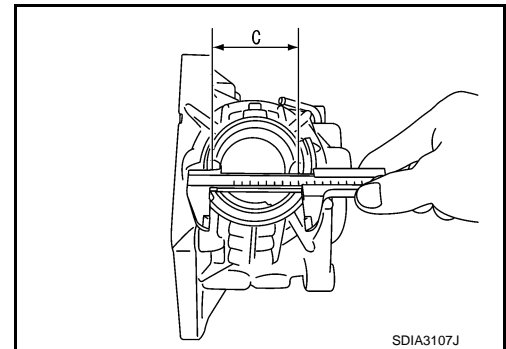

Dimension "D" measurement

- Measure dimension from adapter case mounting surface of transfer case to drive pinion bearing (rear side) mounting surface with a pair of vernier calipers and straightedge. Refer to "Measuring point".

CAUTION:

- Never damage transfer case.
- Consider the thickness of a straightedge.

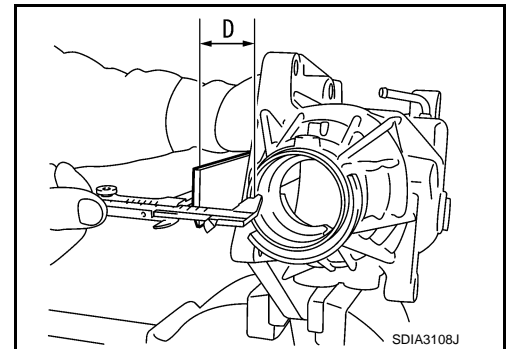

Dimension "F" measurement

DRIVE PINION

< UNIT DISASSEMBLY AND ASSEMBLY >

[TRANSFER: TY30A]

- Measure dimension from adapter case mounting surface of transfer case to ring gear adjusting shim mounting surface with a depth gauge. Refer to "Measuring point".

CAUTION:

Never damage transfer case.

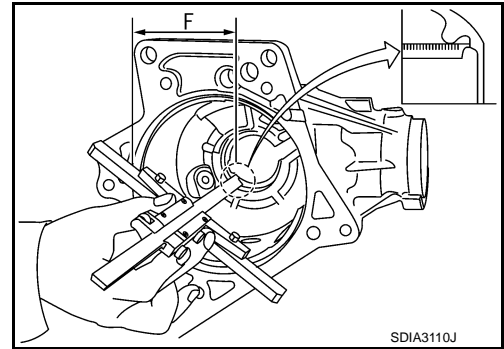

A
B
C

DLN

Dimension "G" measurement

- Measure dimension from ring gear shaft bearing mounting surface of ring gear to transfer case side edge surface with a micrometer and straightedge. Refer to "Measuring point".

CAUTION:

Consider the thickness of a straightedge.

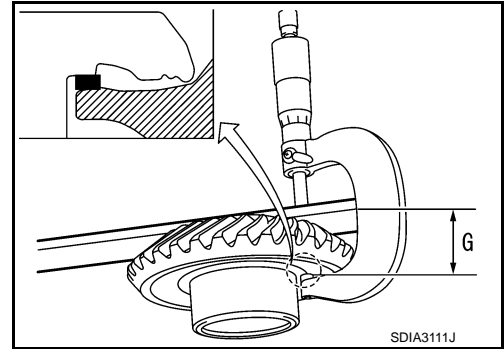

E
F
G

H

Dimension "H" measurement

- Measure dimension from transfer case side edge surface of ring gear to adapter case side edge surface with a pair of vernier calipers. Refer to "Measuring point".

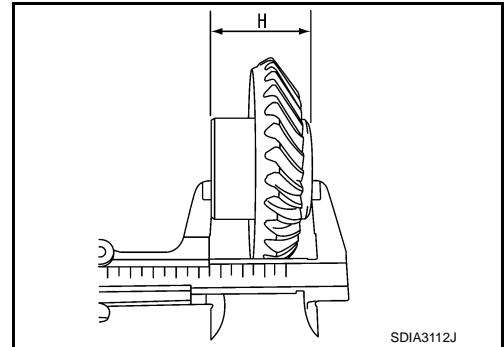

I
J
K

L

Dimension "I" measurement

- Measure dimension from ring gear mounting surface of ring gear shaft to ring gear shaft bearing (transfer case side) mounting surface with a pair of vernier calipers. Refer to "Measuring point".

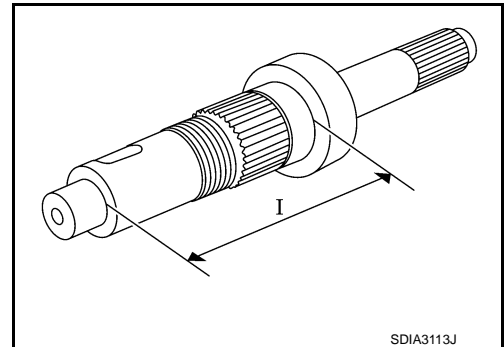

M
N
O

P

Dimension "J" measurement

DRIVE PINION

< UNIT DISASSEMBLY AND ASSEMBLY >

[TRANSFER: TY30A]

- Measure dimension from outer race edge surface of ring gear shaft bearing (transfer case side) to inner race edge surface with a pair of vernier calipers. Refer to “Measuring point”.

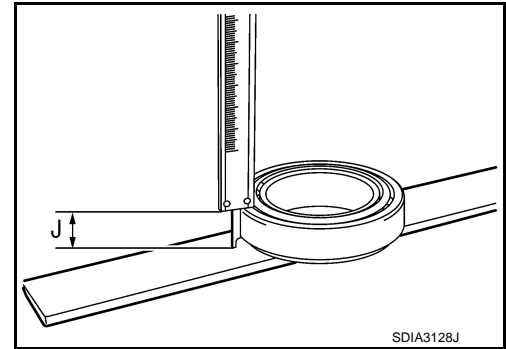

2. Calculate dimension “N” by the formula below.

$$\text{Dimension “N”} = \text{“C”} \times 0.5 \text{ mm (0.020 in)} + \text{“D”}$$

3. Convert the dimensions “F”, “G”, “H”, “I”, “J” and “N” according to the standards below.

- “F” : Decide actual value regarding 122.60 mm (4.83 in) as 0 in increments of 0.01 mm (0.0004 in).
- “G” : Decide actual value regarding 26.60 mm (1.0472 in) as 0 in increments of 0.01 mm (0.0004 in).
- “H” : Decide actual value regarding 48.60 mm (1.9134 in) as 0 in increments of 0.01 mm (0.0004 in).
- “I” : Decide actual value regarding 119.40 mm (4.70 in) as 0 in increments of 0.01 mm (0.0004 in).
- “J” : Decide actual value regarding 16.25 mm (0.6398 in) as 0 in increments of 0.01 mm (0.0004 in).
- “N” : Decide actual value regarding 55.00 mm (2.1654 in) as 0 in increments of 0.01 mm (0.0004 in).

4. Check dimension “Z” (machining difference) on the ring gear back surface.

NOTE:

Dimension “Z” indicates difference between optimum engagement and the standard dimensions in increments of 0.01 mm (0.0004 in) written on the ring gear back surface.

5. Calculate the thickness of the ring gear adjusting shim (transfer case side) “T₂” by the formula below.

$$\text{“T}_2\text{”} = (\text{“F”} - \text{“G”} + \text{“H”} - \text{“I”} - \text{“J”} - \text{“N”} + \text{“Z”}) \times 0.01 \text{ mm (0.0004 in)} + 1.65 \text{ mm (0.0650 in)}$$

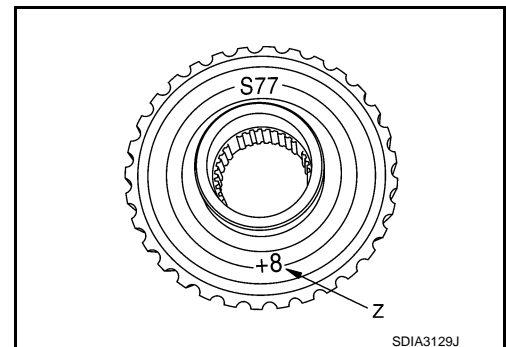

6. Select ring gear adjusting shim (transfer case side). For selecting adjusting shim, refer to the latest parts information.

CAUTION:

- Only one adjusting shim can be selected.
- Select the closest one, favoring thicker over thinner when necessary if no adjusting shim with the calculated value is available.

Drive Pinion Adjusting Shim

DRIVE PINION

< UNIT DISASSEMBLY AND ASSEMBLY >

[TRANSFER: TY30A]

1. Check the dimension “U” (machining difference) between old and new drive pinions when hypoid gear set (drive pinion and ring gear) has been replaced.

(Assemble new drive pinion adjusting shims with the same thickness as the ones removed prior to disassembly or removed drive pinion adjusting shims when reusing the hypoid gear set.)

NOTE:

Dimension “U” indicates the difference between optimum engagement and the standard dimensions in increments of 0.01 mm (0.0004 in). It is written on the gear end of the drive pinion for reference.

2. Calculate the thickness of the drive pinion adjusting shim “T” by the formula below.

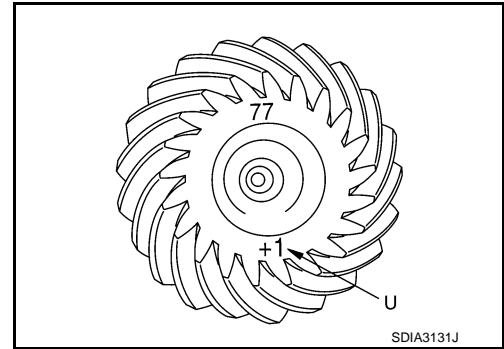

$$\text{“T”} = T_0 + [(t_1 - t_2) \times 0.01 \text{ mm (0.0004 in)}]$$

“T” : Thickness of new shim

T₀ : Thickness of old shim

t₁ : Dimension “U” displayed on the gear end of old drive pinion

t₂ : Dimension “U” displayed on the gear end of new drive pinion

[Example]

$$\text{“T”} = 3.21 + [(2 + 1) \times 0.01 \text{ mm (0.0004 in)}]$$

T₀ : 3.21

t₁ : +2

t₂ : -1

3. Select drive pinion adjusting shim. For selecting adjusting shim, refer to the latest parts information.

CAUTION:

- Only one adjusting shim can be selected.
- Select the closest one, if no adjusting shim with the calculated value is available.

Inspection After Disassembly

INFOID:000000008280134

Check items below. If necessary, replace them with new ones.

GEAR AND SHAFT

Check gear face and shaft for wear, cracks, damage, and seizure.

CAUTION:

Replace ring gear and drive pinion as a set (hypoid gear set) if any malfunction is detected on the ring gear or drive pinion.

BEARING

Check for seizure, peeling, wear, corrosion, sticking, unusual noise, roughness in hand turning, and other damage.

CAUTION:

Always replace inner race and outer race as a pair when replacing the bearing.

SHIM

Check for seizure, damage, and unusual wear.

CASE

Check the bearing mounting surface for wear, cracks and damages.

A
B
C
DLN
E
F
G
H
I
J
K
L
M
N
O
P

TRANSFER CASE

< UNIT DISASSEMBLY AND ASSEMBLY >

[TRANSFER: TY30A]

TRANSFER CASE

Exploded View

INFOID:000000008280135

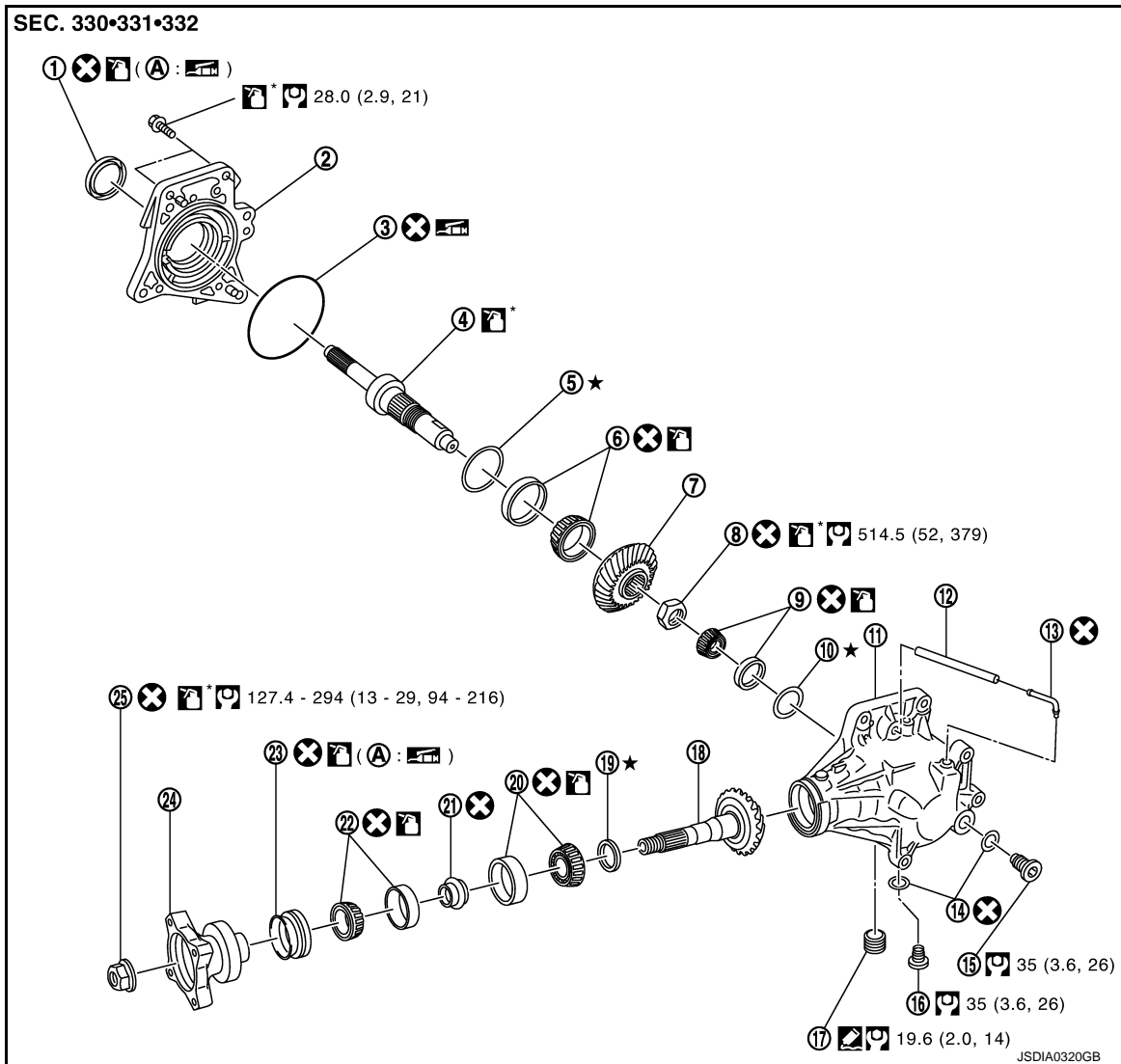

- | | | |
|---|---|---|
| 1. Adapter case oil seal | 2. Adapter case | 3. O-ring |
| 4. Ring gear shaft | 5. Ring gear adjusting shim (adapter case side) | 6. Ring gear shaft bearing (adapter case side) |
| 7. Ring gear | 8. Ring gear nut | 9. Ring gear shaft bearing (transfer case side) |
| 10. Ring gear adjusting shim (transfer case side) | 11. Transfer case | 12. Air breather hose |
| 13. Air breather tube | 14. Gasket | 15. Filler plug |
| 16. Drain plug | 17. Plug | 18. Drive pinion |
| 19. Drive pinion adjusting shim | 20. Drive pinion bearing (front side) | 21. Collapsible spacer |
| 22. Drive pinion bearing (rear side) | 23. Drive pinion oil seal | 24. Companion flange |
| 25. Lock nut | | |

A: Oil seal lip

: Apply gear oil.

: Apply multi-purpose grease.

TRANSFER CASE

< UNIT DISASSEMBLY AND ASSEMBLY >

[TRANSFER: TY30A]

 : Apply anti-corrosive oil.

 : Apply Genuine Silicone RTV or equivalent. Refer to [GI-22, "Recommended Chemical Products and Sealants"](#).
Refer to [GI-4, "Components"](#) for symbols not described above.

Disassembly

INFOID:000000008280136

1. Remove adapter case. Refer to [DLN-59, "Disassembly"](#).
2. Remove ring gear shaft assembly. Refer to [DLN-62, "Disassembly"](#).
3. Remove drive pinion assembly. Refer to [DLN-66, "Disassembly"](#).
4. Tap the outer race of drive pinion bearing from transfer case with a brass rod to remove outer race of drive pinion bearing (front side and rear side).
CAUTION:
Never damage transfer case.
5. Remove air breather hose from transfer case.
CAUTION:
Never damage air breather hose.
6. Remove air breather tube from transfer case.
7. Remove the filler plug and drain plug from the transfer case, and then remove each gasket.
8. Remove plug from transfer case.

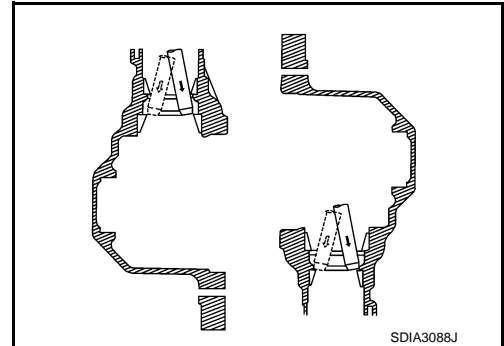

Assembly

INFOID:000000008280137

1. Install outer race of drive pinion bearing (front side) to the transfer case with drifts and bushing remover.

- A : Drift [SST: ST30621000 (J-35869)]
- B : Drift [SST: ST35272000 (J-26092)]
- C : Bushing remover [SST: ST38280000 (J-38198)]

- CAUTION:**
- **Never reuse drive pinion bearing (front side).**
 - **Apply gear oil to the drive pinion bearing (front side)**

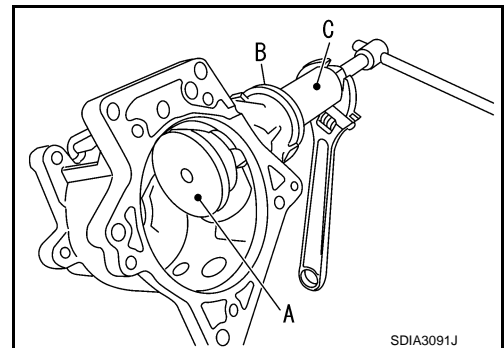

2. Install outer race of drive pinion bearing (rear side) to transfer case with a drift (A) [SST: ST33230000 (J-35867)].

- CAUTION:**
- **Never reuse drive pinion bearing (rear side).**
 - **Apply gear oil to the drive pinion bearing (rear side).**

3. Install drive pinion assembly. Refer to [DLN-67, "Assembly"](#).
4. Install ring gear shaft assembly. Refer to [DLN-63, "Assembly"](#).
5. Install adapter case. Refer to [DLN-59, "Assembly"](#).

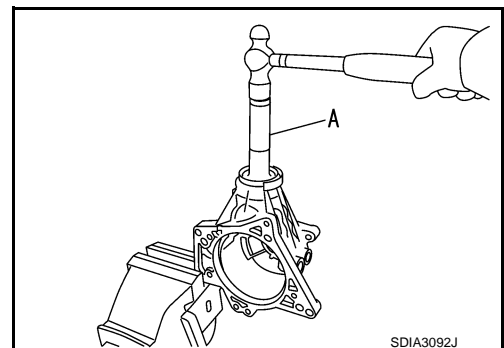

TRANSFER CASE

< UNIT DISASSEMBLY AND ASSEMBLY >

[TRANSFER: TY30A]

6. Install the air breather tube to the transfer case with its opening facing (A) rearward from transfer input shaft direction (B).

Angle "A" : 25° – 45°

CAUTION:

Never reuse air breather tube.

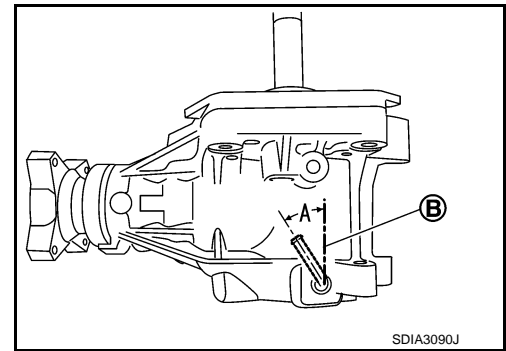

7. Install air breather hose.

- With paint on hose

CAUTION:

- Face the paint area (A) in the position shown in the figure.
- Never damage air breather hose.

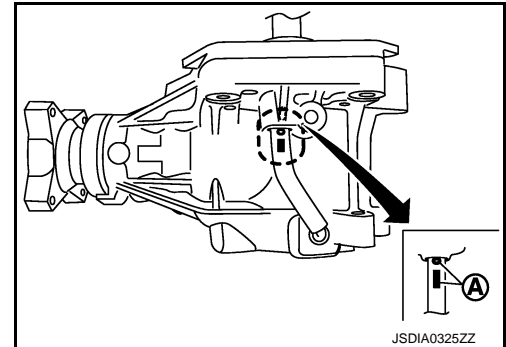

- Without paint on hose

CAUTION:

- Measure hose standard insertion length (A) and put marking on it before installation, then install hose to the marked position.

Insertion length (A) : 59 – 69 mm (2.32 – 2.72 in)

- For marking, use paint.
- Never damage air breather hose.

8. Check backlash, tooth contact, total preload and companion flange runout. Refer to [DLN-68, "Adjustment"](#).

CAUTION:

Measure the total preload without the adapter case oil seals.

9. Assemble the plug to the transfer case.

CAUTION:

- Remove old gasket on mounting surface, then remove any moisture, oil, and foreign material on the application and mounting surfaces.
- Apply liquid gasket to the threads of plug.

10. Install gaskets onto filler plug and drain plug and install them into transfer case.

CAUTION:

- Never reuse gaskets.
- Install filler plug after oil is filled.

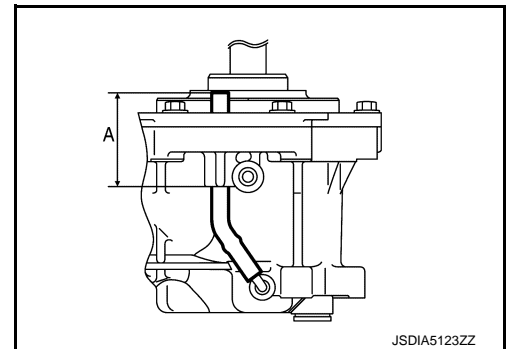

Inspection

INFOID:000000008280138

Check items below. If necessary, replace them with new ones.

CASE

Check the bearing mounting surface for wear, cracks and damages.

SERVICE DATA AND SPECIFICATIONS (SDS)

< SERVICE DATA AND SPECIFICATIONS (SDS)

[TRANSFER: TY30A]

SERVICE DATA AND SPECIFICATIONS (SDS)

SERVICE DATA AND SPECIFICATIONS (SDS)

General Specifications

INFOID:0000000008280139

Applied model	AWD	
	QR25DE	
	CVT	
Transfer model	TY30A	
Oil capacity (Approx.)	ℓ (US pt, Imp pt)	0.36 (3/4, 5/8)
Gear ratio	0.656	
Number of teeth	Ring gear	32
	Drive pinion	21

Preload Torque

INFOID:0000000008280140

Unit: N·m (kg·m, in·lb)

Item	Standard	
Drive pinion bearing preload (P1)	0.52 – 1.01 (0.06 – 0.10, 5 – 8)	
Total preload	With all oil seals	P1 + 0.71 – 0.91 (0.08 – 0.09, 7 – 8)
	Without adapter case oil seal	P1 + 0.55 – 0.75 (0.06 – 0.07, 5 – 6)

Backlash

INFOID:0000000008280141

Unit: mm (in)

Item	Standard
Ring gear to drive pinion	0.13 – 0.19 (0.0051 – 0.0075)

Companion Flange Runout

INFOID:0000000008280142

Unit: mm (in)

Item	Limit
Companion flange face (inner side of the propeller shaft bolt holes)	0.1 (0.004)
Inside of companion flange (socket diameter)	0.2 (0.008)

NOISE, VIBRATION AND HARSHNESS (NVH) TROUBLESHOOTING

< SYMPTOM DIAGNOSIS >

[REAR PROPELLER SHAFT: 3F SPL18-DOJ75]

SYMPTOM DIAGNOSIS

NOISE, VIBRATION AND HARSHNESS (NVH) TROUBLESHOOTING

NVH Troubleshooting Chart

INFOID:000000008280143

Use the chart below to find the cause of the symptom. If necessary, repair or replace these parts.

Symptom		Possible cause and SUSPECTED PARTS													
		Uneven rotating torque	Center bearing improper installation	Excessive center bearing axial end play	Center bearing mounting (insulator) cracks, damage or deterioration	Excessive joint angle	Rotation imbalance	Excessive runout	DIFFERENTIAL	AXLE AND SUSPENSION	TIRE	ROAD WHEEL	DRIVE SHAFT	BRAKE	STEERING
Noise	Noise	x	x	x	x	x	x	x	x	x	x	x	x	x	x
	Shake		x			x				x	x	x	x	x	x
	Vibration	x	x	x	x	x	x	x		x	x		x		x
Reference		DLN-84, "Inspection"	DLN-87, "Inspection"	—	DLN-87, "Inspection"	—	DLN-87, "Inspection"	DLN-84, "Inspection"	NVH of REAR FINAL DRIVE in this section.	NVH in FAX, RAX, FSU and RSU section	NVH in WT section	NVH in WT section	NVH in FAX and RAX section	NVH in BR section	NVH in ST section

x: Applicable

PREPARATION

[REAR PROPELLER SHAFT: 3F SPL18-DOJ75]

< PREPARATION >

PREPARATION

PREPARATION

Commercial Service Tool

INFOID:000000008280144

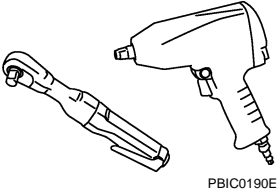
Tool name	Description
<p data-bbox="164 411 277 438">Power tool</p>  <p data-bbox="873 632 943 646">PBIC0190E</p>	<p data-bbox="1068 411 1321 438">Loosening bolts and nuts</p>

A

B

C

DLN

E

F

G

H

I

J

K

L

M

N

O

P

REAR PROPELLER SHAFT

< PERIODIC MAINTENANCE >

[REAR PROPELLER SHAFT: 3F SPL18-DOJ75]

PERIODIC MAINTENANCE

REAR PROPELLER SHAFT

Inspection

INFOID:000000008280145

NOISE

- Check the propeller shaft tube surface for dents or cracks. If damaged, replace propeller shaft assembly.
- If center bearing is noisy or damaged, replace propeller shaft assembly.

VIBRATION

If vibration is present at high speed, inspect propeller shaft runout first.

1. With a dial indicator, measure propeller shaft runout at runout measuring points by rotating final drive companion flange with hands.

Propeller shaft runout : Refer to [DLN-89, "Propeller Shaft Runout"](#).

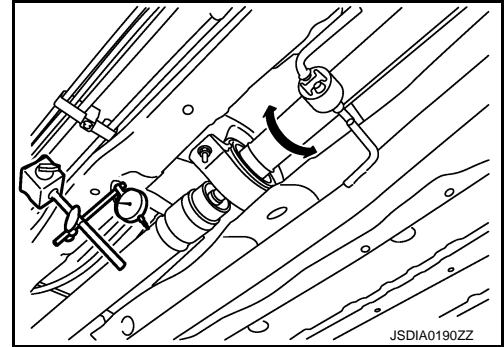

- Propeller shaft runout measuring point (Point "△").

↔ : Vehicle front

Dimension **A: 501 mm (19.72 in)**
 B: 445 mm (17.52 in)

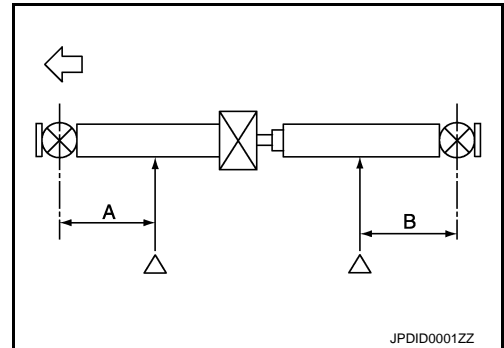

2. If runout still exceeds specifications, separate propeller shaft at final drive companion flange or transfer companion flange; then change the phase between companion flange and propeller shaft by the one bolt hole at a time and install propeller shaft.
3. Check runout again. If runout still exceeds specifications, replace propeller shaft assembly.
4. Check the vibration by driving vehicle.

REAR PROPELLER SHAFT

< REMOVAL AND INSTALLATION >

[REAR PROPELLER SHAFT: 3F SPL18-DOJ75]

REMOVAL AND INSTALLATION

REAR PROPELLER SHAFT

Exploded View

INFOID:000000008280146

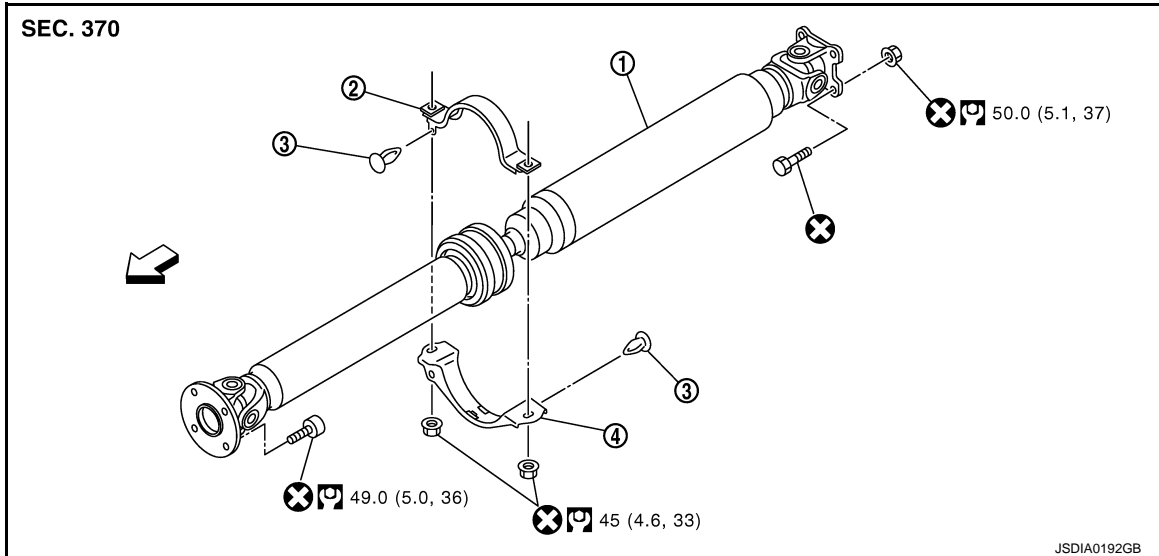

1. Propeller shaft assembly
2. Center bearing mounting bracket (upper)
3. Clip
4. Center bearing mounting bracket (lower)

↔: Vehicle front

Refer to [GI-4, "Components"](#) for symbols in the figure.

Removal and Installation

INFOID:000000008280147

REMOVAL

1. Shift the transaxle to the neutral position, and then release the parking brake.
2. Remove the following parts with power tool.
 - Muffler assembly: Refer to [EX-4, "Exploded View"](#).
 - Exhaust center tube: Refer to [EX-4, "Exploded View"](#).
3. Put matching marks onto propeller shaft flange yoke and final drive and transfer companion flanges.

CAUTION:

For matching marks, use paint. Never damage propeller shaft flange yoke and transfer companion flange.

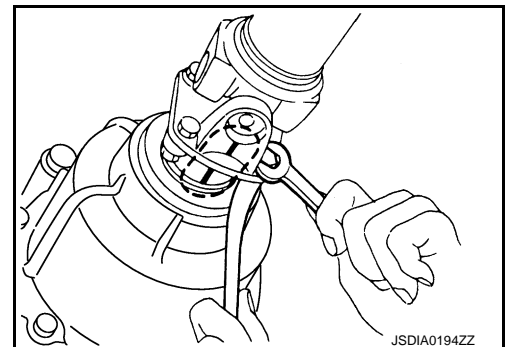

REAR PROPELLER SHAFT

< REMOVAL AND INSTALLATION >

[REAR PROPELLER SHAFT: 3F SPL18-DOJ75]

- Loosen mounting nuts of center bearing mounting brackets (upper/lower).

↔ : Vehicle front

CAUTION:

Tighten mounting nuts temporarily.

- Remove propeller shaft assembly fixing bolts and nuts.
- Remove center bearing mounting bracket fixing nuts.
- Remove propeller shaft assembly.

CAUTION:

If constant velocity joint was bent during propeller shaft assembly removal, installation, or transportation, its boot may be damaged. Wrap boot interference area to metal part with shop cloth or rubber to protect boot from breakage.

- Remove clips and center bearing mounting bracket (upper/lower).

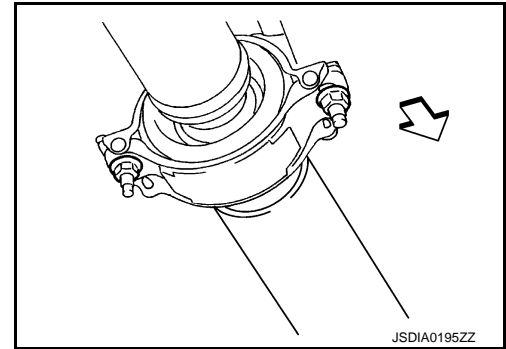

INSTALLATION

Note the following, and install in the reverse order of removal.

- Install center bearing mounting bracket (upper) (1) with its arrow mark (A) facing forward.
- Adjust position of center bearing mounting bracket (upper), center bearing mounting bracket (lower) (2) sliding back and forth to prevent play in thrust direction of center bearing insulator (3). Install center bearing mounting bracket (upper/lower) to vehicle.
- Align matching marks to install propeller shaft assembly to final drive and transfer companion flanges.
- Perform inspection after installation. Refer to [DLN-87, "Inspection"](#).

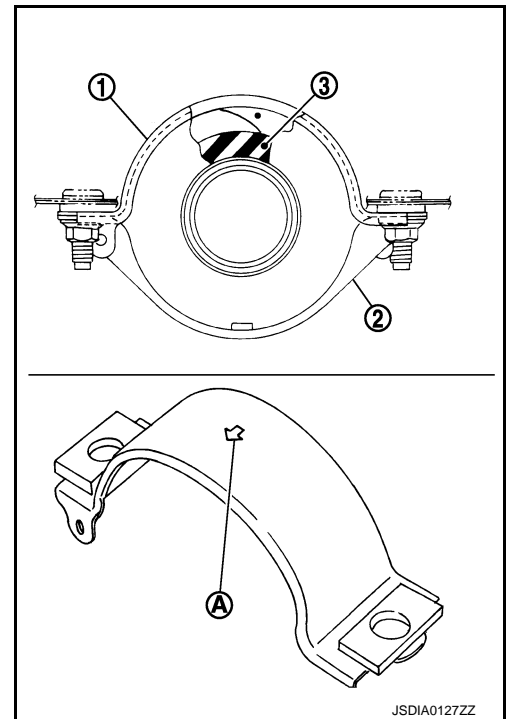

- After tightening the bolts and nuts to the specified torque, make sure that the bolts (3) on the flange side is tightened as shown in the figure.

- 1 : Final drive assembly
- 2 : Propeller shaft assembly

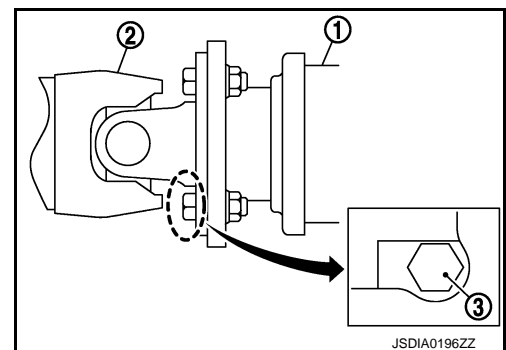

- If propeller shaft assembly or final drive assembly has been replaced, connect them as follows:

REAR PROPELLER SHAFT

< REMOVAL AND INSTALLATION >

[REAR PROPELLER SHAFT: 3F SPL18-DOJ75]

- Face the companion flange mark (A) of the final drive (1) upward. With the mark (A) faced upward, couple the propeller shaft and the final drive so that the matching mark (B) of propeller shaft (2) can be positioned as closest as possible with the matching mark (C) of the final drive companion flange.
- Tighten mounting bolts and nuts of propeller shaft and final drive to the specified torque.

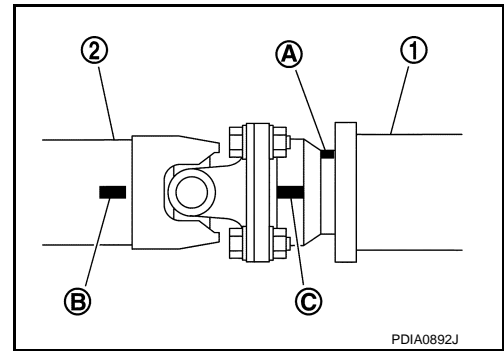

PDA0892J

INFOID:000000008280148

Inspection

INSPECTION AFTER REMOVAL

Appearance

Check propeller shaft for bend and damage. If damage is detected, replace propeller shaft assembly.

Propeller Shaft Runout

Check propeller shaft runout at measuring points with a dial indicator. If runout exceeds specifications, replace propeller shaft assembly.

Limit

Propeller shaft runout

: Refer to [DLN-89, "Propeller Shaft Runout"](#).

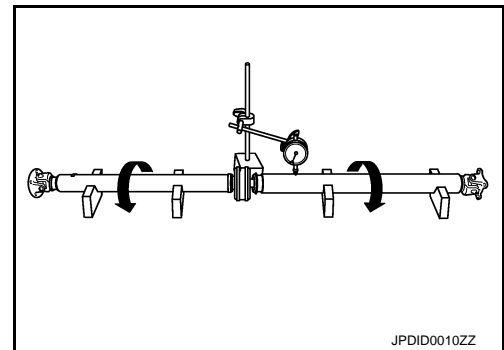

JPDID0010ZZ

- Propeller shaft runout measuring point (Point "△").

← : Vehicle front

Dimension

A: 501 mm (19.72 in)

B: 445 mm (17.52 in)

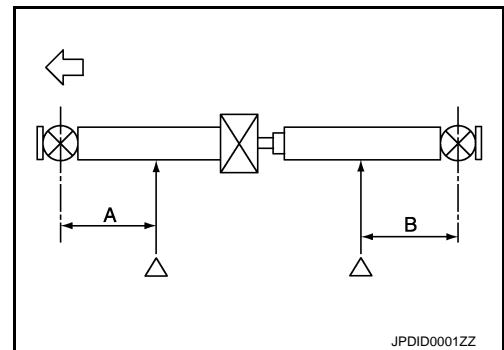

JPDID0001ZZ

Journal Axial Play

As shown in the figure, while fixing yoke on one side, check axial play of joint. If it is outside the standard, replace propeller shaft assembly.

Standard

Journal axial play

: Refer to [DLN-89, "Journal Axial Play"](#).

CAUTION:

Never disassemble joints.

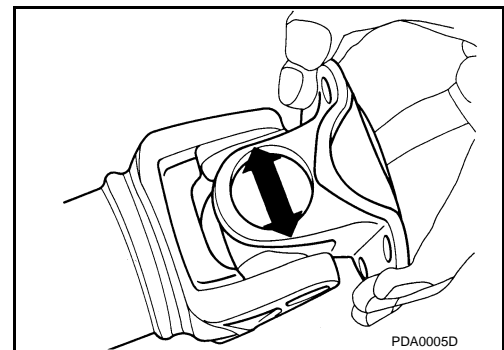

PDA0005D

Center Bearing

Check center bearing for noise and damage. If noise or damage is detected, replace propeller shaft assembly.

CAUTION:

Never disassemble center bearing.

REAR PROPELLER SHAFT

< REMOVAL AND INSTALLATION >

[REAR PROPELLER SHAFT: 3F SPL18-DOJ75]

INSPECTION AFTER INSTALLATION

After assembly, perform a driving test to check propeller shaft vibration. If vibration occurred, separate propeller shaft from final drive or transfer. Reinstall companion flange by changing the phase between companion flange and propeller shaft by the one bolt hole at a time. Then perform driving test and check propeller shaft vibration again at each point.

SERVICE DATA AND SPECIFICATIONS (SDS)

< SERVICE DATA AND SPECIFICATIONS (SDS) [REAR PROPELLER SHAFT: 3F SPL18-DOJ75]

SERVICE DATA AND SPECIFICATIONS (SDS)

SERVICE DATA AND SPECIFICATIONS (SDS)

General Specifications

INFOID:000000008280149

Applied model		AWD
		QR25DE
		CVT
Propeller shaft model		3F SPL18-DOJ75
Number of joints		3
Type of journal bearings (Non-disassembly type)	1st joint	Shell type
	2nd joint	DOJ type
	3rd joint	Shell type
Coupling method with transfer		Flange type
Coupling method with rear final drive		Flange type
Shaft length	1st (Spider to DOJ joint center)	1110 mm (43.70 in)
	2nd (DOJ joint center to spider)	887 mm (34.92 in)
Shaft outer diameter	1st	57 mm (2.24 in)
	2nd	70 mm (2.76 in)

Propeller Shaft Runout

INFOID:000000008280150

Unit: mm (in)

Item	Limit
Propeller shaft runout	0.6 (0.024)

Journal Axial Play

INFOID:000000008280151

Unit: mm (in)

Item	Standard
Journal axial play	0 (0)

REAR FINAL DRIVE ASSEMBLY

< SYSTEM DESCRIPTION >

[REAR FINAL DRIVE: R145]

SYSTEM DESCRIPTION

REAR FINAL DRIVE ASSEMBLY

System Diagram

INFOID:000000008280152

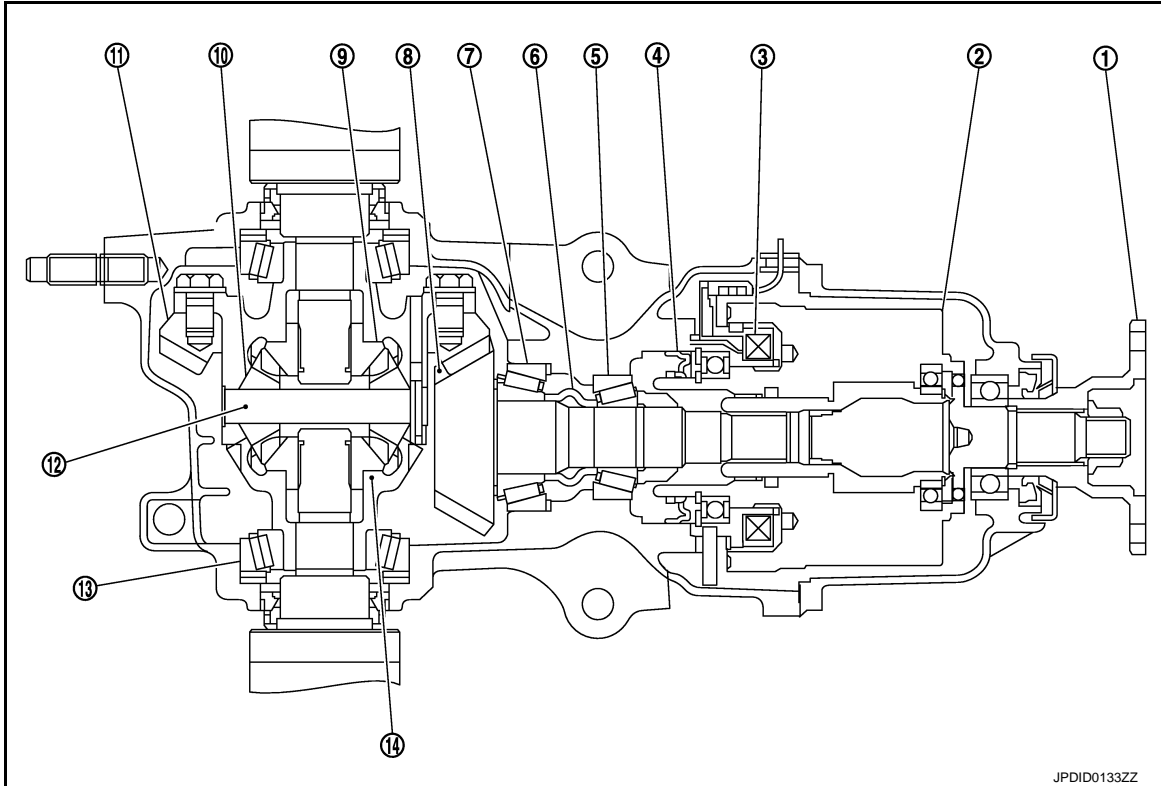

- | | | |
|------------------------|---------------------------------|-----------------------|
| 1. Companion flange | 2. Electric controlled coupling | 3. AWD solenoid |
| 4. Center oil seal | 5. Pinion front bearing | 6. Collapsible spacer |
| 7. Pinion rear bearing | 8. Drive pinion | 9. Side gear |
| 10. Pinion mate gear | 11. Drive gear | 12. Pinion mate shaft |
| 13. Side bearing | 14. Differential case | |

NOISE, VIBRATION AND HARSHNESS (NVH) TROUBLESHOOTING

< SYMPTOM DIAGNOSIS >

[REAR FINAL DRIVE: R145]

SYMPTOM DIAGNOSIS

NOISE, VIBRATION AND HARSHNESS (NVH) TROUBLESHOOTING

NVH Troubleshooting Chart

INFOID:000000008280153

Use the chart below to find the cause of the symptom. If necessary, repair or replace these parts.

Symptom	Noise														
Reference			DLN-116, "Inspection After Disassembly"	DLN-123, "Adjustment"	DLN-116, "Inspection After Disassembly"	DLN-123, "Adjustment"	DLN-123, "Adjustment"	DLN-96, "Inspection"	NVH of REAR PROPELLER SHAFT in this section.	NVH in FAX, RAX, FSU and RSU sections	NVH in WT section	NVH in WT section	NVH in FAX and RAX section	NVH in BR section	NVH in ST section
Possible cause and SUSPECTED PARTS		Gear tooth rough	Gear contact improper	Tooth surfaces worn	Backlash incorrect	Companion flange excessive runout	Gear oil improper	PROPELLER SHAFT	AXLE AND SUSPENSION	TIRE	ROAD WHEEL	DRIVE SHAFT	BRAKE	STEERING	
		x	x	x	x	x	x	x	x	x	x	x	x	x	x

x: Applicable

A
B
C
DLN
E
F
G
H
I
J
K
L
M
N
O
P

PRECAUTION

PRECAUTIONS

Service Notice or Precautions for Rear Final Drive

INFOID:000000008280154

- Check for the correct installation status prior to removal or disassembly. If matching marks are required, be certain they never interfere with the function of the parts when applied.
- Overhaul should be done in a clean work area, it is preferable to work in dustproof area.
- Before disassembly, using steam or white gasoline, completely remove sand and mud from the exterior of the unit, preventing them from entering into the unit during disassembly or assembly.
- Check appearance of the disassembled parts for damage, deformation, and unusual wear. Replace them with a new one if necessary.
- Gaskets, seals and O-rings should be replaced any time when the unit is disassembled.
- In principle, tighten bolts or nuts gradually in several steps working diagonally from inside to outside. If tightening sequence is specified, observe it.
- Clean and flush the parts sufficiently and blow-dry them.
- Never damage sliding surfaces and mating surfaces.
- When applying sealant, remove the old sealant from the mounting surface; then remove any moisture, oil, and foreign materials from the application and mounting surfaces.
- Always use shop paper for cleaning the inside of components.
- Avoid using cotton gloves or shop rags to prevent entering of lint.
- During assembly, observe the specified tightening torque, and apply new gear oil, petroleum jelly, or multi-purpose grease as specified for each vehicle, if necessary.

PREPARATION

< PREPARATION >

[REAR FINAL DRIVE: R145]

PREPARATION

PREPARATION

Special Service Tools

INFOID:000000008280155

The actual shapes of TechMate tools may differ from those of special service tools illustrated here.

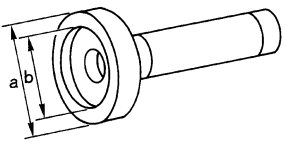
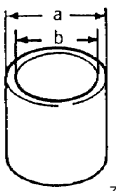
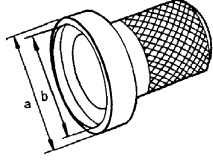
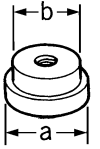
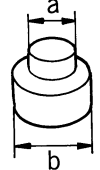
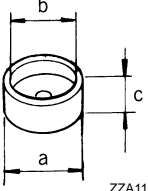
Tool number (TechMate No.) Tool name	Description
KV38100200 (J-26233) Drift a: 65 mm (2.56 in) dia. b: 49 mm (1.93 in) dia.	 <p style="text-align: center;">ZZA1143D</p> <ul style="list-style-type: none"> Installing front oil seal Installing side oil seal
ST27861000 (—) Drift a: 62 mm (2.44 in) dia. b: 52 mm (2.05 in) dia.	 <p style="text-align: center;">ZZA0832D</p> <p>Installing front oil seal</p>
ST35271000 (J-26091) Drift a: 72 mm (2.83 in) dia. b: 63 mm (2.48 in) dia.	 <p style="text-align: center;">ZZA0814D</p> <p>Installing center oil seal</p>
KV40100610 (J-26089) Drift a: 63 mm (2.48 in) dia. b: 54.3 mm (2.138 in) dia.	 <p style="text-align: center;">ZZA1000D</p> <p>Removing and installing gear carrier and rear cover (2 pieces are used)</p>
ST33052000 (—) Drift a: 22 mm (0.87 in) dia. b: 28 mm (1.10 in) dia.	 <p style="text-align: center;">ZZA1023D</p> <p>Removing side bearing inner race</p>
KV40105020 (—) Drift a: 39.7 mm (1.563 in) dia. b: 35 mm (1.38 in) dia. c: 15 mm (0.59 in)	 <p style="text-align: center;">ZZA1133D</p> <p>Installing side bearing inner race</p>

A
B
C
DLN
E
F
G
H
I
J
K
L
M
N
O
P

PREPARATION

< PREPARATION >

[REAR FINAL DRIVE: R145]

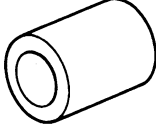
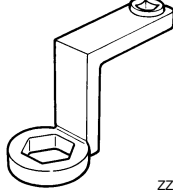
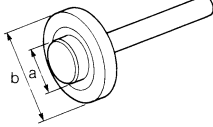
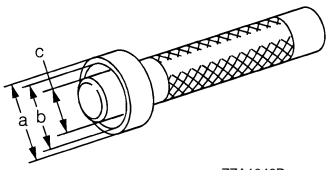
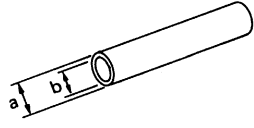
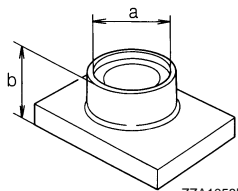
Tool number (TechMate No.) Tool name	Description
KV38109500 (—) Drive pinion socket	<ul style="list-style-type: none"> • Removing and installing drive pinion nut • Measuring preload torque
 ZZA1205D	
KV38109400 (—) Pinion nut wrench	Removing and installing drive pinion nut
 ZZA1206D	
ST17130000 (—) Drift a: 31.8 mm (1.252 in) dia. b: 58 mm (2.28 in) dia.	Installing pinion rear bearing outer race
 ZZA0836D	
ST33230000 (J-25805-01) Drift a: 51 mm (2.01 in) dia. b: 41 mm (1.61 in) dia. c: 28.5 mm (1.122 in) dia.	Installing pinion front bearing outer race
 ZZA1046D	
ST23860000 (—) Drift a: 38 mm (1.50 in) dia. b: 33 mm (1.30 in) dia.	<ul style="list-style-type: none"> • Installing pinion rear bearing inner race • Installing pinion front bearing inner race
 ZZA0534D	
ST38220000 (—) Press stand a: 63 mm (2.48 in) b: 65 mm (2.56 in) dia.	Installing pinion front bearing inner race
 ZZA1058D	

PREPARATION

< PREPARATION >

[REAR FINAL DRIVE: R145]

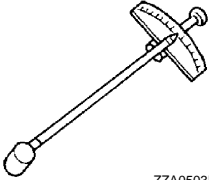
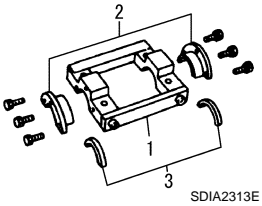
Tool number (TechMate No.) Tool name	Description	
ST3127S000 (J-25765-A) Preload gauge	 ZZA0503D	A B C
KV381086S1 (—) Dummy cover set 1. KV38108610 (—) Dummy cover 2. KV38108621 (—) Dummy cover spacer 3. KV38108630 (—) Dummy cover shim	 SDIA2313E	DLN E F G

Commercial Service Tools

INFOID:000000008280156

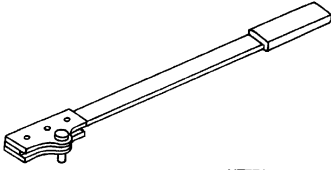
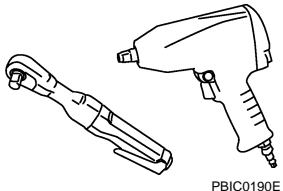
Tool name	Description	
Flange wrench	 NT771	H I J
Power tool	 PBIC0190E	K L M

A
B
C
DLN
E
F
G
H
I
J
K
L
M
N
O
P

PERIODIC MAINTENANCE

REAR DIFFERENTIAL GEAR OIL

Inspection

INFOID:000000008280157

OIL LEAKAGE

Make sure that oil is not leaking from final drive assembly or around it.

OIL LEVEL

- Remove filler plug (1) and check oil level from filler plug mounting hole as shown in the figure.

CAUTION:

Never start engine while checking oil level.

- Set a new gasket on filler plug and install it on final drive assembly. Refer to [DLN-106, "Exploded View"](#).

CAUTION:

Never reuse gasket.

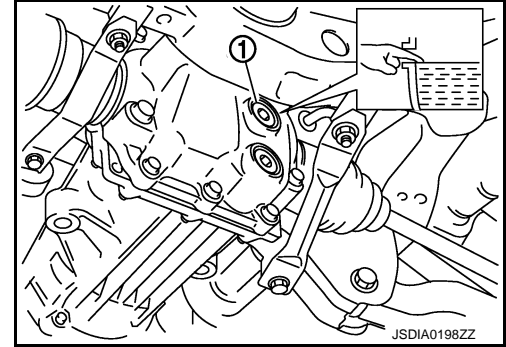

JSDIA0198ZZ

Draining

INFOID:000000008280158

- Stop engine.
- Remove drain plug (1) and drain gear oil.
- Set a new gasket on drain plug and install it to final drive assembly and tighten to the specified torque. Refer to [DLN-106, "Exploded View"](#).

CAUTION:

Never reuse gasket.

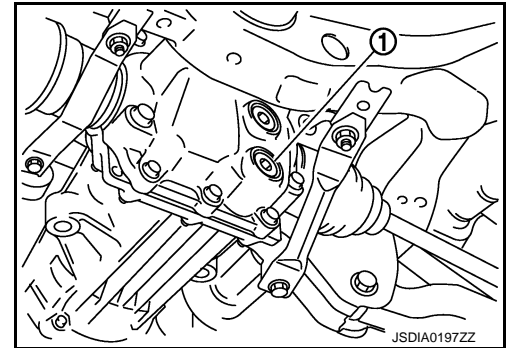

JSDIA0197ZZ

Refilling

INFOID:000000008280159

- Remove filler plug (1). Fill with new gear oil until oil level reaches the specified level near filler plug mounting hole.

Oil grade and viscosity

: Refer to [MA-15, "FOR NORTH AMERICA : Fluids and Lubricants"](#) (for NORTH AMERICA), [MA-16, "FOR MEXICO : Fluids and Lubricants"](#) (for MEXICO).

Oil capacity

: Refer to [DLN-128, "General Specification"](#).

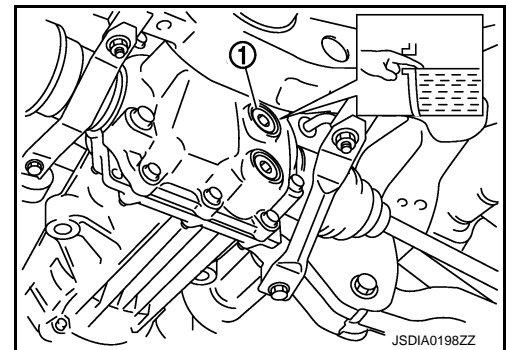

JSDIA0198ZZ

- After refilling oil, check oil level. Set a new gasket to filler plug, then install it to final drive assembly. Refer to [DLN-106, "Exploded View"](#).

CAUTION:

Never reuse gasket.

REMOVAL AND INSTALLATION

FRONT OIL SEAL

Exploded View

INFOID:000000008280160

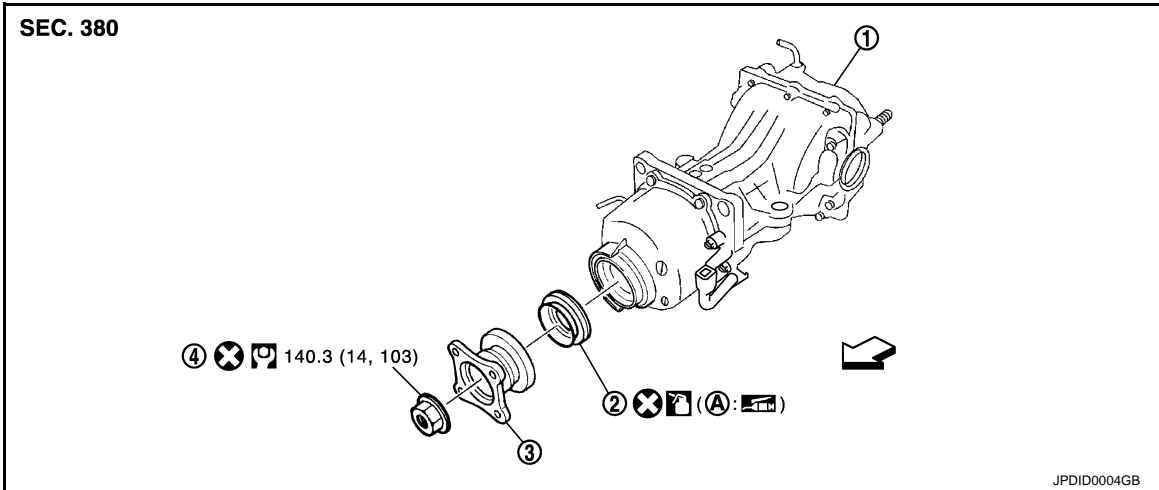

- 1. Final drive assembly
 - 2. Front oil seal
 - 3. Companion flange
 - 4. Companion flange lock nut
- A: Oil seal lip

↔: Vehicle front

: Apply gear oil.

Refer to [GI-4. "Components"](#) for symbols not described above.

Removal and Installation

INFOID:000000008280161

REMOVAL

1. Remove rear propeller shaft. Refer to [DLN-85. "Exploded View"](#).
2. Put matching mark on the thread edge of electric controlled coupling. The matching mark should be in line with the matching mark on companion flange.

CAUTION:
For matching mark, use paint. Never damage electric controlled coupling.

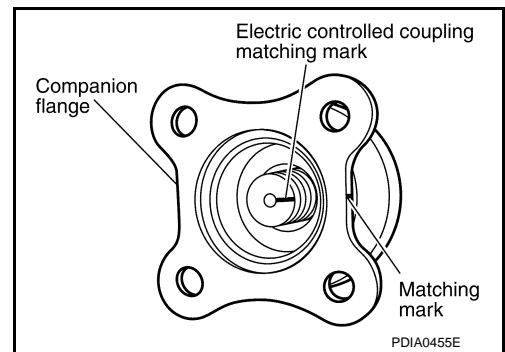

FRONT OIL SEAL

< REMOVAL AND INSTALLATION >

[REAR FINAL DRIVE: R145]

3. Remove companion flange lock nut, using a flange wrench (commercial service tool). Then remove companion flange.

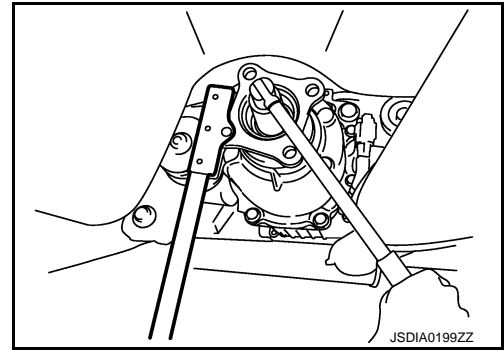

4. Remove front oil seal from coupling cover, using a suitable tool.
CAUTION:
Never damage coupling cover.

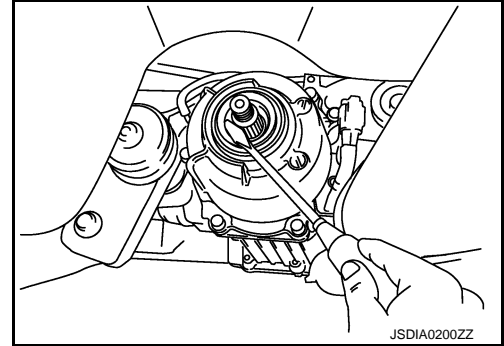

INSTALLATION

1. Install front oil seal until it becomes flush with the coupling cover end, using the drifts.

A : Drift [SST: KV38100200 (J-26233)]

B : Drift [SST: ST27861000 (—)]

CAUTION:

- Never reuse oil seal.
- When installing, never incline oil seal.
- Apply multi-purpose grease onto oil seal lips, and gear oil onto the circumference of oil seal.

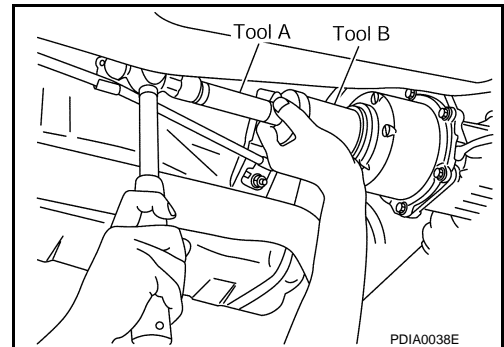

2. Align the matching mark of electric controlled coupling with the matching mark of companion flange, then install the companion flange.
3. Install companion flange lock nut with a flange wrench (commercial service tool), tighten to the specified torque.

CAUTION:

Never reuse companion flange lock nut.

4. Install rear propeller shaft. Refer to [DLN-85, "Exploded View"](#).
5. When oil leaks while removing, check oil level after the installation. Refer to [DLN-96, "Inspection"](#).

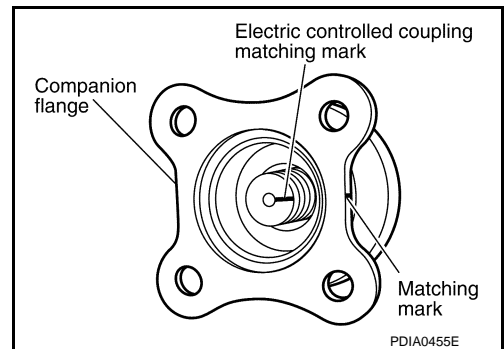

SIDE OIL SEAL

< REMOVAL AND INSTALLATION >

[REAR FINAL DRIVE: R145]

SIDE OIL SEAL

Exploded View

INFOID:000000008280162

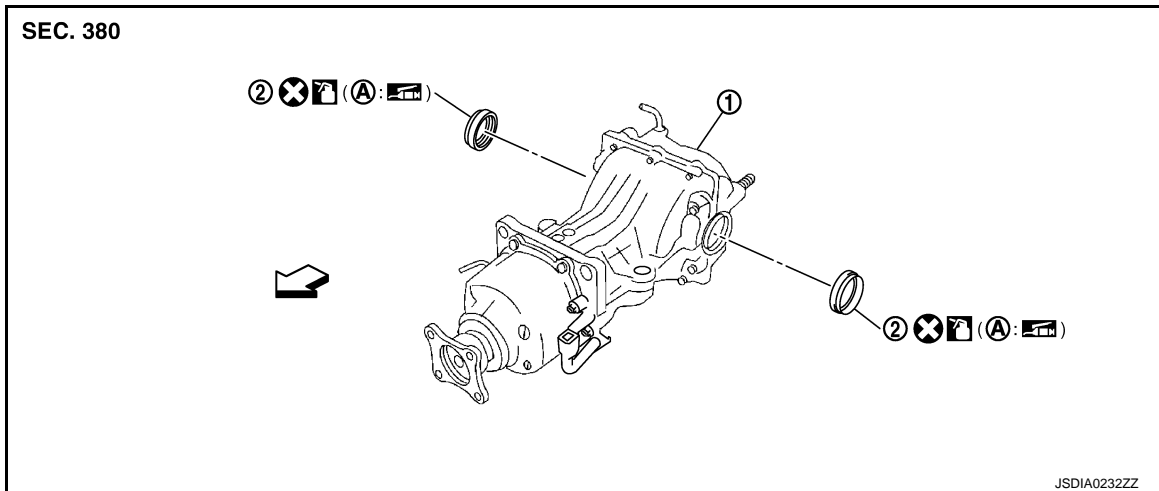

1. Final drive assembly 2. Side oil seal

A: Oil seal lip

←: Vehicle front

: Apply gear oil.

Refer to [GI-4, "Components"](#) for symbols not described above.

Removal and Installation

INFOID:000000008280163

REMOVAL

1. Remove rear drive shafts with power tool. Refer to [RAX-16, "Exploded View"](#).
2. Remove side oil seals, using a suitable tool.

CAUTION:
Never damage gear carrier and rear cover.

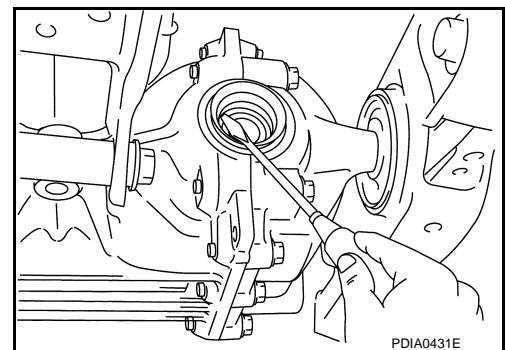

INSTALLATION

1. Install side oil seals until it becomes flush with the carrier end, using the drift (A) [SST: KV38100200 (J-26233)].

CAUTION:

- Never reuse oil seals.
- When installing, never incline oil seals.
- Apply multi-purpose grease onto oil seal lips, and gear oil onto the circumference of oil seal.

2. Install rear drive shafts. Refer to [RAX-16, "Exploded View"](#).
3. When oil leaks while removing, check oil level after the installation. Refer to [DLN-96, "Inspection"](#).

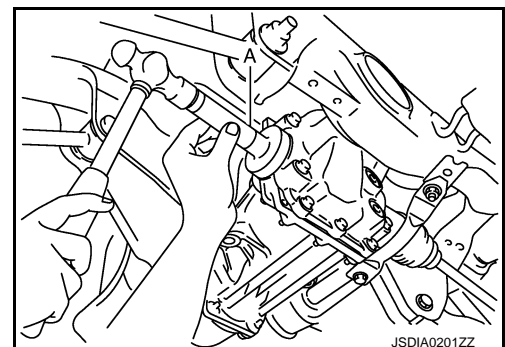

ELECTRIC CONTROLLED COUPLING

< REMOVAL AND INSTALLATION >

[REAR FINAL DRIVE: R145]

ELECTRIC CONTROLLED COUPLING

Exploded View

INFOID:000000008280164

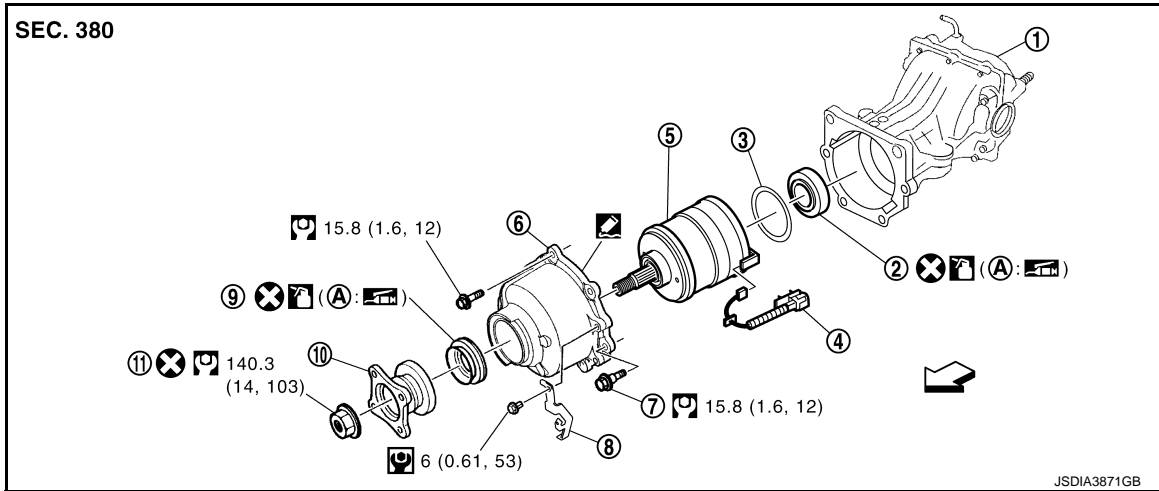

- | | | |
|-------------------------|----------------------------------|-------------------|
| 1. Final drive assembly | 2. Center oil seal* | 3. Wave spring |
| 4. AWD solenoid harness | 5. Electric controlled coupling* | 6. Coupling cover |
| 7. Reamer bolt | 8. Connector bracket | 9. Front oil seal |
| 10. Companion flange | 11. Companion flange lock nut | |

A. Oil seal lip

*: When replacing electric controlled coupling, replace center oil seal.

←: Vehicle front

: Apply gear oil.

: Apply Genuine Silicone RTV or equivalent. Refer to [GI-22, "Recommended Chemical Products and Sealants"](#).

Refer to [GI-4, "Components"](#) for symbols not described above.

Removal and Installation

INFOID:000000008280165

REMOVAL

1. Remove rear propeller shaft. Refer to [DLN-85, "Exploded View"](#).
2. Disconnect AWD solenoid harness connector.
3. Remove connector bracket.
4. Put matching mark on the thread edge of electric controlled coupling. The matching mark should be in line with the matching mark on the companion flange.

CAUTION:

For matching mark, use paint. Never damage electric controlled coupling.

NOTE:

When replacing electric controlled coupling, matching mark is not necessary.

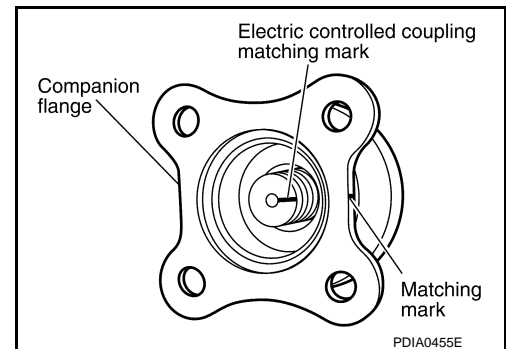

ELECTRIC CONTROLLED COUPLING

< REMOVAL AND INSTALLATION >

[REAR FINAL DRIVE: R145]

5. Remove companion flange lock nut, using a flange wrench (commercial service tool).
6. Remove companion flange.
7. Remove electric controlled coupling breather hose from coupling cover.

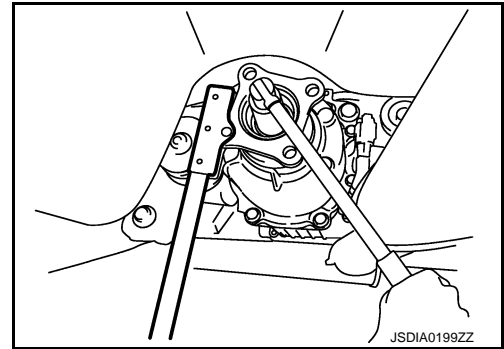

8. Remove coupling cover with electric controlled coupling from final drive assembly.
9. Remove wave spring.
10. Remove center oil seal from final drive assembly.
CAUTION:
When removing electric controlled coupling, replace center oil seal.
11. Remove electric controlled coupling from coupling cover.
12. Remove AWD solenoid harness.

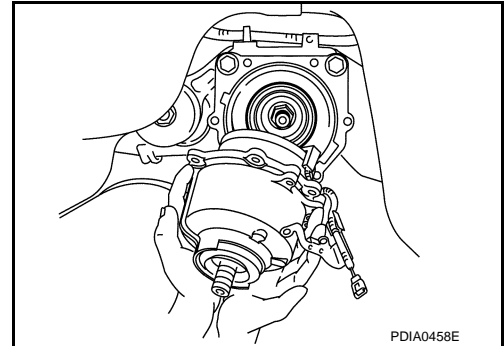

13. Remove front oil seal from coupling cover, using a suitable tool.
CAUTION:
Never damage coupling cover.

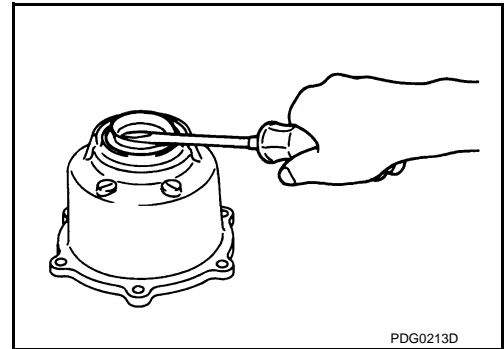

INSTALLATION

1. Using the drift (A) [SST: ST35271000 (J-26091)], install center oil seal (1) as shown in the figure.

Dimension (D) : 0.05 – 0.45 mm (0.0020 – 0.0177 in)

CAUTION:

- Never reuse oil seal.
- When installing, never incline oil seal.
- Apply multi-purpose grease onto oil seal lips, and gear oil onto the circumference of oil seal.
- The specifications of center oil seals depend on the vehicle mounted electric controlled coupling. Therefore, when replacing only a center oil seal, measure the inner diameter of the removed center oil seal to install a new one appropriate to the electric controlled coupling. For selecting oil seal, refer to the latest parts information.

2. Install wave spring to gear carrier.
3. Connect AWD solenoid harness to electric controlled coupling.

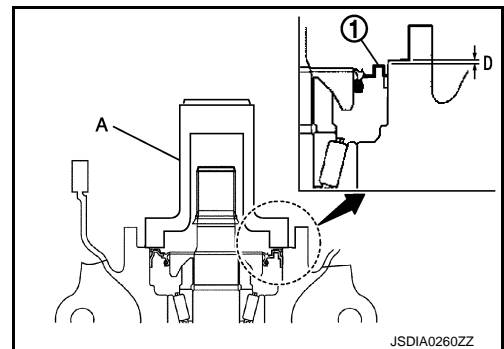

ELECTRIC CONTROLLED COUPLING

< REMOVAL AND INSTALLATION >

[REAR FINAL DRIVE: R145]

4. Install electric controlled coupling to spline of drive pinion inside gear carrier.

CAUTION:

- Align the pin on electric controlled coupling with the groove of gear carrier.
- Never damage center oil seal.

5. Set AWD solenoid harness guide to gear carrier.

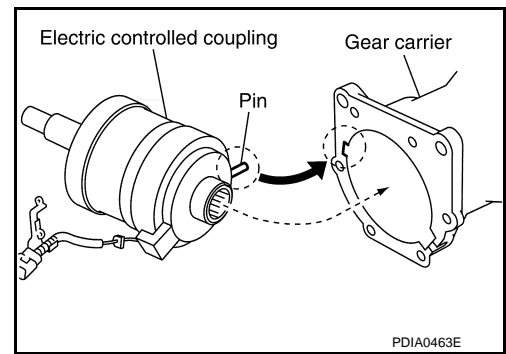

6. Using the drifts, drive front oil seal until it becomes flush with the coupling cover end.

A : Drift [SST: KV38100200 (J-26233)]

B : Drift [SST: ST27861000 (—)]

CAUTION:

- Never reuse oil seal.
- When installing, never incline oil seal.
- Apply multi-purpose grease onto oil seal lips, and gear oil onto the circumference of oil seal.

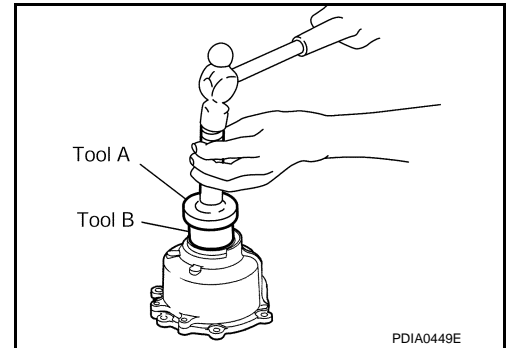

7. Apply liquid gasket to mating surface of coupling cover. Overlap both ends of the bead for at least 3 mm (0.12 in).

- Use Genuine Silicone RTV or equivalent. Refer to [GI-22, "Recommended Chemical Products and Sealants"](#).

CAUTION:

Remove old gasket adhering to the mounting surfaces. Also remove any moisture, oil, or foreign material adhering to the mounting surfaces.

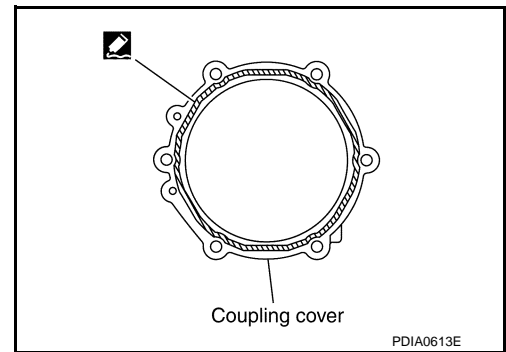

8. Install coupling cover to final drive assembly with arrow facing upward, temporarily tighten reamer bolts to the positions shown in the figure.

9. Tighten reamer bolts and coupling cover mounting bolts to the specified torque.

10. Install electric controlled coupling breather hose to coupling cover.

11. Install connector bracket, and tighten bolts to the specified torque.

12. Connect AWD solenoid harness connector.

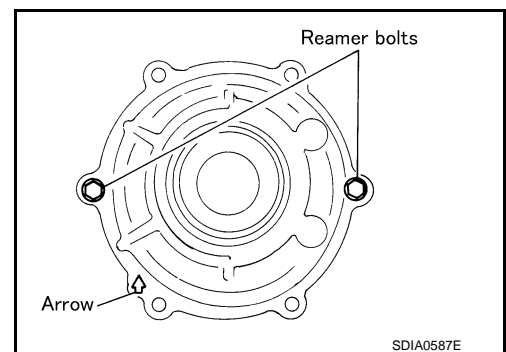

13. Install companion flange.

NOTE:

When reusing electric controlled coupling, align the matching mark of electric controlled coupling with the matching mark of companion flange, then install companion flange.

14. Install companion flange lock nut with flange wrench (commercial service tool), tighten to the specified torque.

CAUTION:

Never reuse companion flange lock nut.

15. Check companion flange runout. Refer to [DLN-109, "Adjustment"](#).

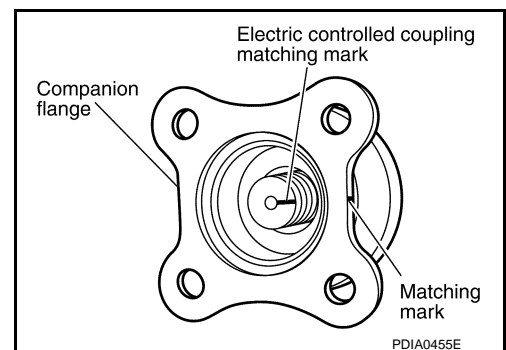

ELECTRIC CONTROLLED COUPLING

< REMOVAL AND INSTALLATION >

[REAR FINAL DRIVE: R145]

16. Install rear propeller shaft. Refer to [DLN-85, "Exploded View"](#).
17. When oil leaks while removing, check oil level after the installation. Refer to [DLN-96, "Inspection"](#).

A
B
C
DLN
E
F
G
H
I
J
K
L
M
N
O
P

REAR FINAL DRIVE ASSEMBLY

< UNIT REMOVAL AND INSTALLATION >

[REAR FINAL DRIVE: R145]

UNIT REMOVAL AND INSTALLATION

REAR FINAL DRIVE ASSEMBLY

Exploded View

INFOID:000000008280166

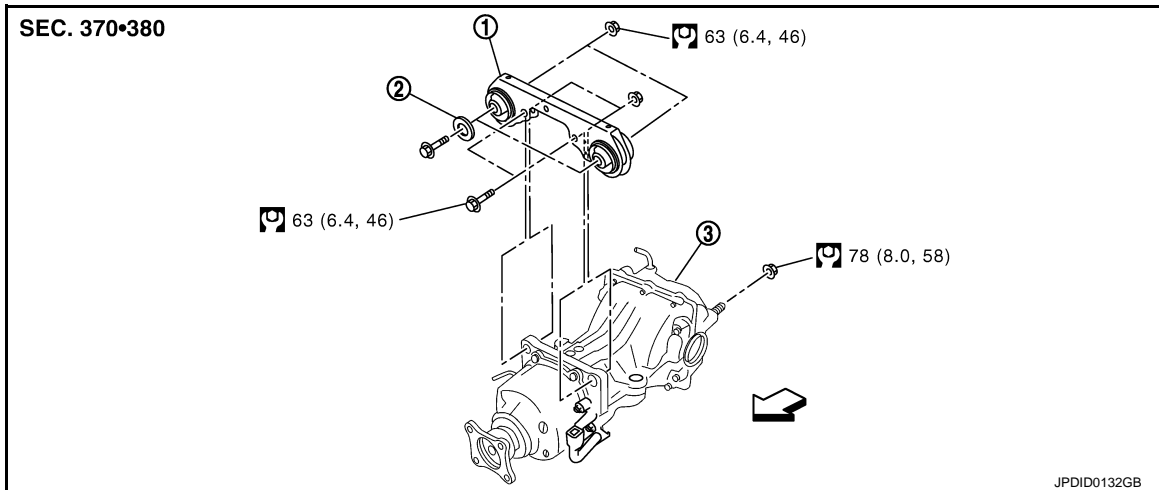

1. Final drive mounting bracket 2. Washer 3. Final drive assembly

↶ Vehicle front

Refer to [GI-4, "Components"](#) for symbols in the figure.

Removal and Installation

INFOID:000000008280167

REMOVAL

1. Remove rear propeller shaft. Refer to [DLN-85, "Exploded View"](#).
2. Remove rear drive shafts. Refer to [RAX-16, "Exploded View"](#).
3. Disconnect AWD solenoid harness connector.
4. Remove rear final drive breather hose and electric controlled coupling breather hose.
5. Support final drive assembly with a suitable jack.
6. Remove final drive mounting nuts and final drive mounting bolts with power tool.
If necessary, remove final drive mounting bracket and washer with power tool.

CAUTION:

Secure final drive assembly to a suitable jack while removing it.

INSTALLATION

Note the following, and install in the reverse order of removal.

CAUTION:

Make sure there are no pinched or restricted areas on the breather hose caused by bending or winding when installing it.

- Install the breatherhose (1) and hose clamp until dimension (A) shown as follows.

A:

Final drive side : 20 mm (0.79 in)

Suspension member side : 20 mm (0.79 in)

CAUTION:

- **Never reuse hose clamp.**
- **Install the hose clamp at the final drive side, with the tab facing down ward.**

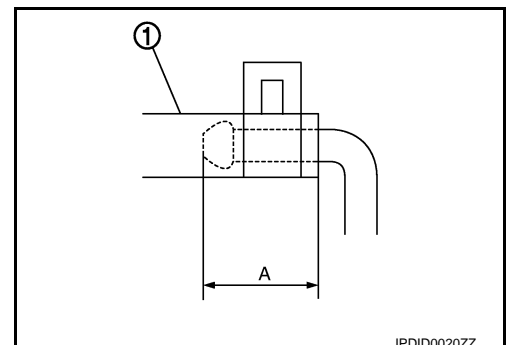

REAR FINAL DRIVE ASSEMBLY

< UNIT REMOVAL AND INSTALLATION >

[REAR FINAL DRIVE: R145]

- Install the breather hose (1) and breather connector (2) as shown in the figure.
- Install rear final drive breather hose (1) to breather connector (2). Install the breather connector to bracket (3).

↔ : Vehicle front

CAUTION:

- **Never reuse bracket clip and metal connector.**
- **If remove metal connector (4), install metal connector to rear cover with aiming paint marking (A) to vehicle front.**

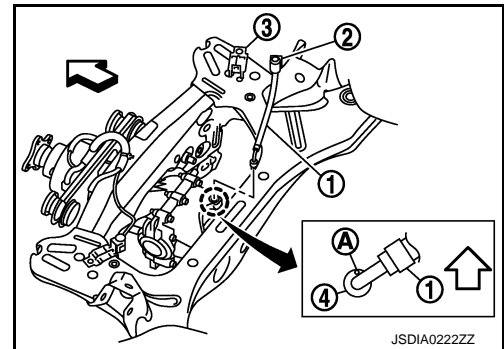

- Install electric controlled coupling breather hose (1) as shown in the figure.
- Install electric controlled coupling breather hose at the coupling side to metal connector (3) of the coupling cover (2) all the way to the point shown by the solid arrow (↔).

↔ : Vehicle front

CAUTION:

- **Never reuse metal connector and hose clip.**
- **If remove metal connector, install metal connector to the coupling cover, facing to vehicle front.**
- When oil leaks while removing final drive assembly, check oil level after the installation. Refer to [DLN-96. "Inspection"](#).

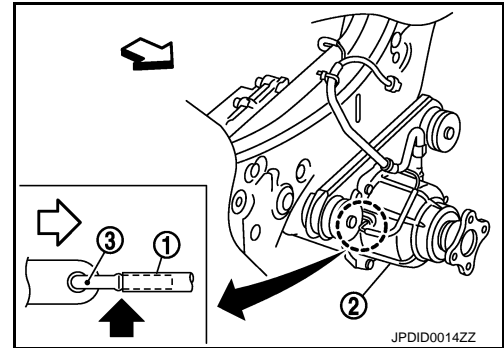

A
B
C
DLN
E
F
G
H
I
J
K
L
M
N
O
P

ELECTRIC CONTROLLED COUPLING

< UNIT DISASSEMBLY AND ASSEMBLY >

[REAR FINAL DRIVE: R145]

UNIT DISASSEMBLY AND ASSEMBLY

ELECTRIC CONTROLLED COUPLING

Exploded View

INFOID:000000008280168

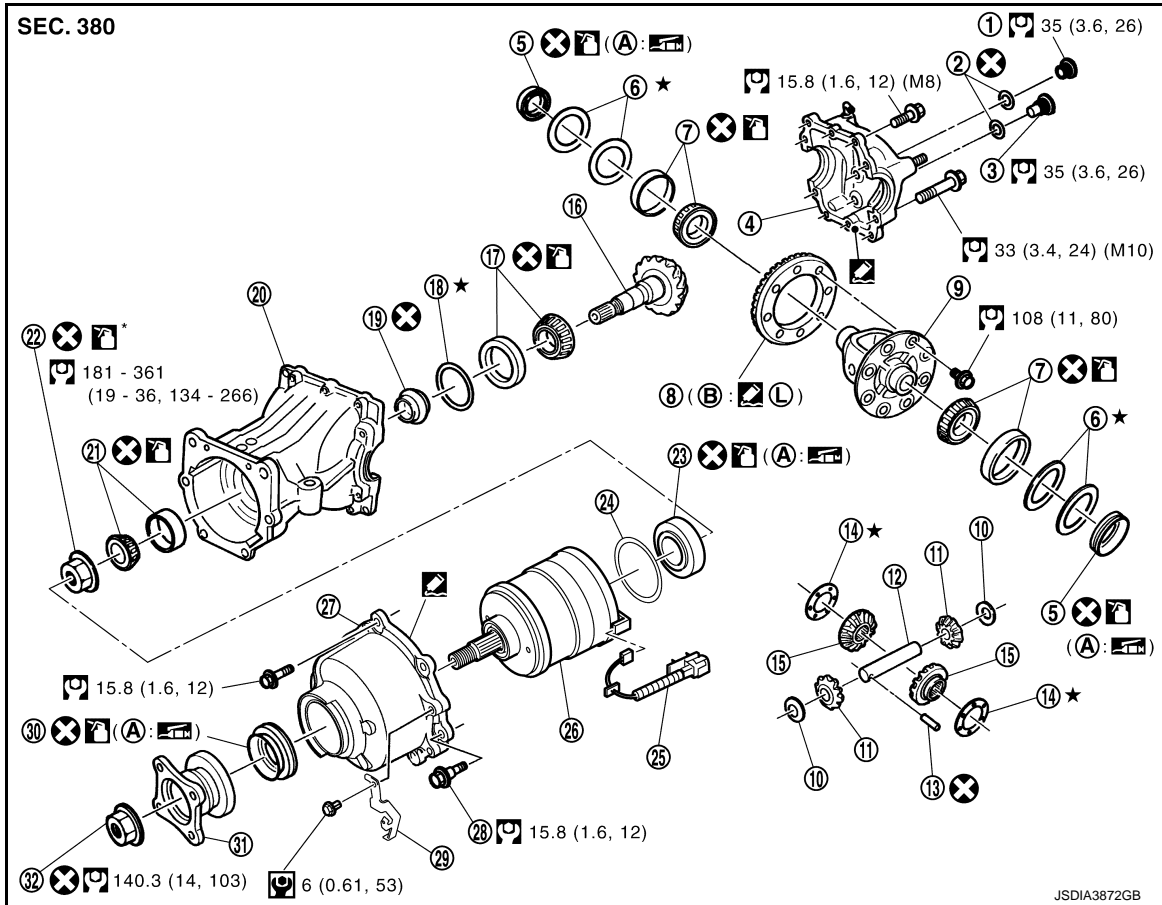

- | | | |
|-------------------------------|-----------------------------------|---------------------------------|
| 1. Filler plug | 2. Gasket | 3. Drain plug |
| 4. Rear cover | 5. Side oil seal | 6. Side bearing adjusting shim |
| 7. Side bearing | 8. Drive gear | 9. Differential case |
| 10. Pinion mate thrust washer | 11. Pinion mate gear | 12. Pinion mate shaft |
| 13. Lock pin | 14. Side gear thrust washer | 15. Side gear |
| 16. Drive pinion | 17. Pinion rear bearing | 18. Drive pinion adjusting shim |
| 19. Collapsible spacer | 20. Gear carrier | 21. Pinion front bearing |
| 22. Drive pinion nut | 23. Center oil seal* | 24. Wave spring |
| 25. AWD solenoid harness | 26. Electric controlled coupling* | 27. Coupling cover |
| 28. Reamer bolt | 29. Connector bracket | 30. Front oil seal |
| 31. Companion flange | 32. Companion flange lock nut | |
- A. Oil seal lip
B. Screw hole

*: When replacing electric controlled coupling, replace center oil seal.

: Apply gear oil.

: Apply anti-corrosive oil.

: Apply Genuine Silicone RTV or equivalent. Refer to [GI-22, "Recommended Chemical Products and Sealants"](#).

ELECTRIC CONTROLLED COUPLING

< UNIT DISASSEMBLY AND ASSEMBLY >

[REAR FINAL DRIVE: R145]

: Apply Genuine High Strength Thread Locking Sealant or equivalent. Refer to [GI-22. "Recommended Chemical Products and Sealants"](#).

Refer to [GI-4. "Components"](#) for symbols not described above.

Disassembly

INFOID:000000008280169

1. Remove connector bracket.
2. Put matching mark on the thread edge of electric controlled coupling. The matching mark should be in line with the matching mark on companion flange.

CAUTION:

For matching mark, use paint. Never damage electric controlled coupling.

NOTE:

When replacing electric controlled coupling, matching mark is not necessary.

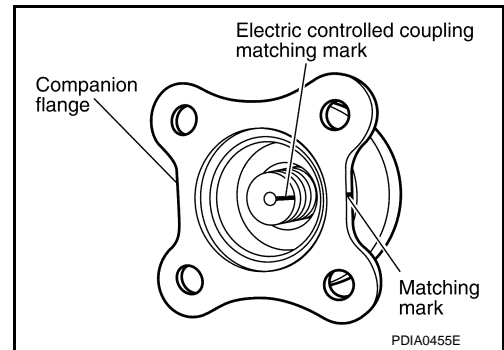

3. Remove companion flange lock nut, using a flange wrench (commercial service tool).
4. Remove companion flange.
5. Remove coupling cover.

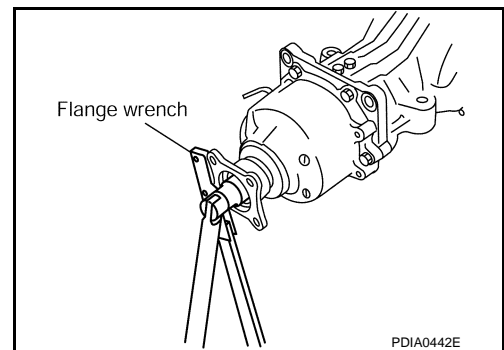

6. Remove front oil seal from coupling cover, using a suitable tool.

CAUTION:

Never damage coupling cover.

7. Remove electric controlled coupling.
8. Remove wave spring.
9. Remove center oil seal from gear carrier.

CAUTION:

When removing electric controlled coupling, replace center oil seal.

10. Remove AWD solenoid harness.

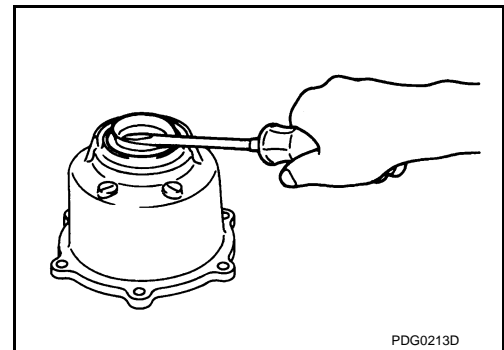

Assembly

INFOID:000000008280170

1. Using the drift (A) [SST: ST35271000 (J-26091)], install center oil seal (1) as shown in the figure.

Dimension (D) : 0.05 – 0.45 mm (0.0020 – 0.0177 in)

CAUTION:

- Never reuse oil seal.
- When installing, never incline oil seal.
- Apply multi-purpose grease onto oil seal lips, and gear oil onto the circumference of oil seal.
- The specifications of center oil seals depend on the vehicle mounted electric controlled coupling. Therefore, when replacing only a center oil seal, measure the inner diame-

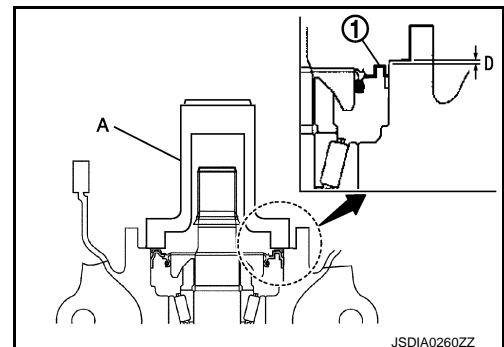

ELECTRIC CONTROLLED COUPLING

< UNIT DISASSEMBLY AND ASSEMBLY >

[REAR FINAL DRIVE: R145]

ter of the removed center oil seal to install a new one appropriate to the electric controlled coupling. For selecting oil seal, refer to the latest parts information.

2. Install wave spring to gear carrier.
3. Connect AWD solenoid harness to electric controlled coupling.
4. Install electric controlled coupling to spline of drive pinion inside gear carrier.

CAUTION:

- Align the pin on electric controlled coupling with the groove of gear carrier.
- Never damage center oil seal.

5. Set AWD solenoid harness guide to gear carrier.

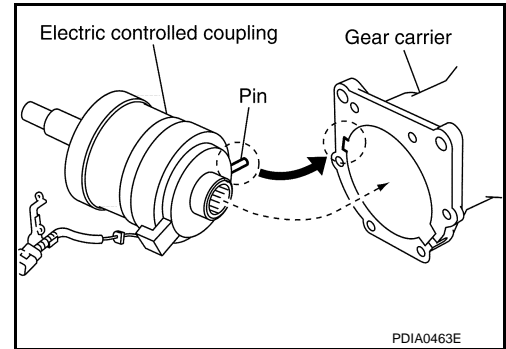

6. Using the drifts, drive front oil seal until it becomes flush with the coupling cover end.

A : Drift [SST: KV38100200 (J-26233)]

B : Drift [SST: ST27861000 (—)]

CAUTION:

- Never reuse oil seal.
- When installing, never incline oil seal.
- Apply multi-purpose grease onto oil seal lips, and gear oil onto the circumference of oil seal.

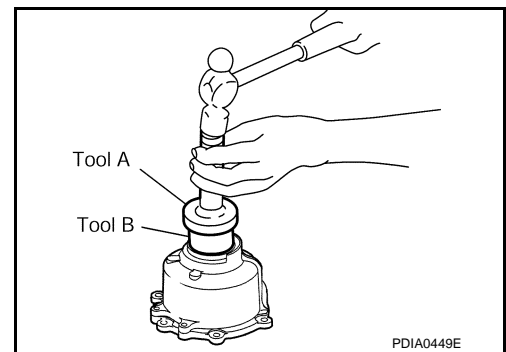

7. Apply liquid gasket to mating surface of coupling cover. Overlap both ends of the bead for at least 3 mm (0.12 in).

- Use Genuine Silicone RTV or equivalent. Refer to [GI-22, "Recommended Chemical Products and Sealants"](#).

CAUTION:

Remove old gasket adhering to the mounting surfaces. Also remove any moisture, oil, or foreign material adhering to the mounting surfaces.

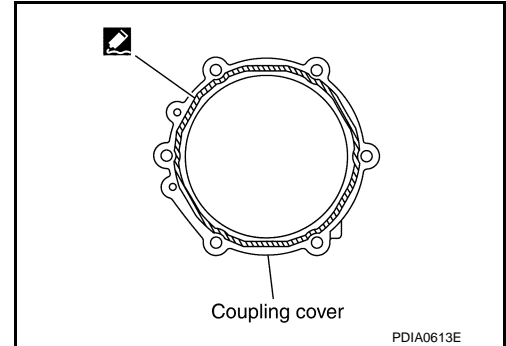

8. Install coupling cover to gear carrier with arrow facing upward, temporarily tighten reamer bolts to the positions shown in the figure.

9. Tighten reamer bolts and coupling cover mounting bolts to the specified torque.

10. Install connector bracket, and tighten bolts to the specified torque.

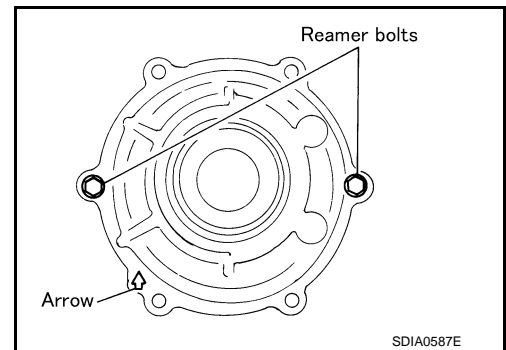

ELECTRIC CONTROLLED COUPLING

< UNIT DISASSEMBLY AND ASSEMBLY >

[REAR FINAL DRIVE: R145]

11. Install companion flange.

NOTE:

When reusing electric controlled coupling, align the matching mark of electric controlled coupling with the matching mark of companion flange, then install companion flange.

12. Install companion flange lock nut with flange wrench (commercial service tool), tighten to the specified torque.

CAUTION:

Never reuse companion flange lock nut.

13. Check companion flange runout. Refer to [DLN-109. "Adjustment"](#).

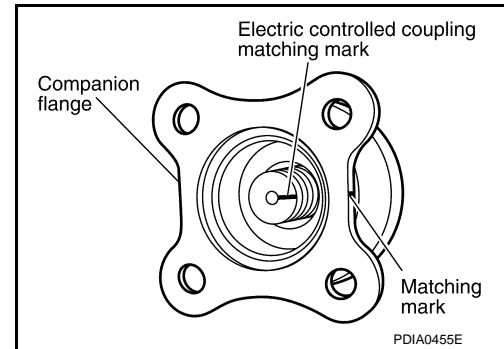

INFOID:000000008280171

Adjustment

COMPANION FLANGE RUNOUT

1. Fit a dial indicator onto the companion flange face (inner side of the rear propeller shaft mounting bolt holes).
2. Rotate companion flange to check for runout.

Limit

Companion flange runout : Refer to [DLN-128. "Companion Flange Runout"](#).

3. Fit a test indicator to the inner side of companion flange (socket diameter).
4. Rotate companion flange to check for runout.

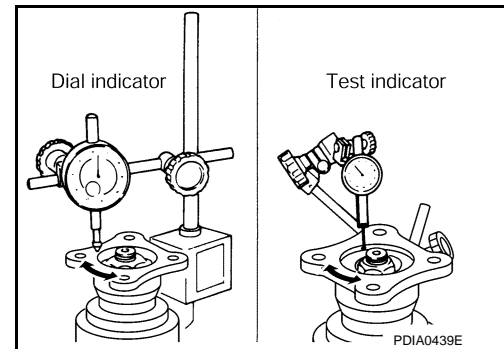

Limit

Companion flange runout : Refer to [DLN-128. "Companion Flange Runout"](#).

5. If the runout value is outside the runout limit, follow the procedure below to adjust.
 - a. Check for runout while changing the phase between companion flange and drive pinion by 90° step, and search for the position where the runout is the minimum.
 - b. If the runout value is still outside of the limit after the phase has been changed, replace companion flange.
 - c. If the runout value is still outside of the limit after companion flange has been replaced, possible cause will be an assembly malfunction of drive pinion and electric controlled coupling, malfunctioning coupling bearing, or malfunctioning of electric controlled coupling.

Inspection After Disassembly

INFOID:000000008280172

DRIVE GEAR AND DRIVE PINION

- Clean up the disassembled parts.
- If the gear teeth never mesh or line-up correctly, determine the cause and adjust or replace as necessary.
- If the gears are worn, cracked, damaged, pitted or chipped (by friction) noticeably, replace with new drive gear and drive pinion as a set.

BEARING

- Clean up the disassembled parts.
- If any chipped (by friction), pitted, worn, rusted or scratched marks, or unusual noise from the bearing is observed, replace as a bearing assembly (as a new set).

SIDE GEAR AND PINION MATE GEAR

- Clean up the disassembled parts.
- If any cracks or damage on the surface of the tooth is found, replace.
- If any worn or chipped mark on the contact sides of the thrust washer is found, replace.

SIDE GEAR THRUST WASHER AND PINION MATE THRUST WASHER

- Clean up the disassembled parts.

A
B
C
DLN

E
F
G
H
I
J
K
L

M
N
O
P

ELECTRIC CONTROLLED COUPLING

< UNIT DISASSEMBLY AND ASSEMBLY >

[REAR FINAL DRIVE: R145]

- If it is chipped (by friction), damaged, or unusually worn, replace.

OIL SEAL

- Whenever disassembled, replace.
- If wear, deterioration of adherence (sealing force lips), or damage is detected on the lips, replace them.

DIFFERENTIAL CASE

- Clean up the disassembled parts.
- If any wear or crack on the contact sides of the differential case is found, replace.

COMPANION FLANGE

- Clean up the disassembled parts.
- If any chipped mark [about 0.1 mm, (0.004 in)] or other damage on the contact sides of the lips of the companion flange is found, replace.

DIFFERENTIAL ASSEMBLY

< UNIT DISASSEMBLY AND ASSEMBLY >

[REAR FINAL DRIVE: R145]

DIFFERENTIAL ASSEMBLY

Exploded View

INFOID:000000008280173

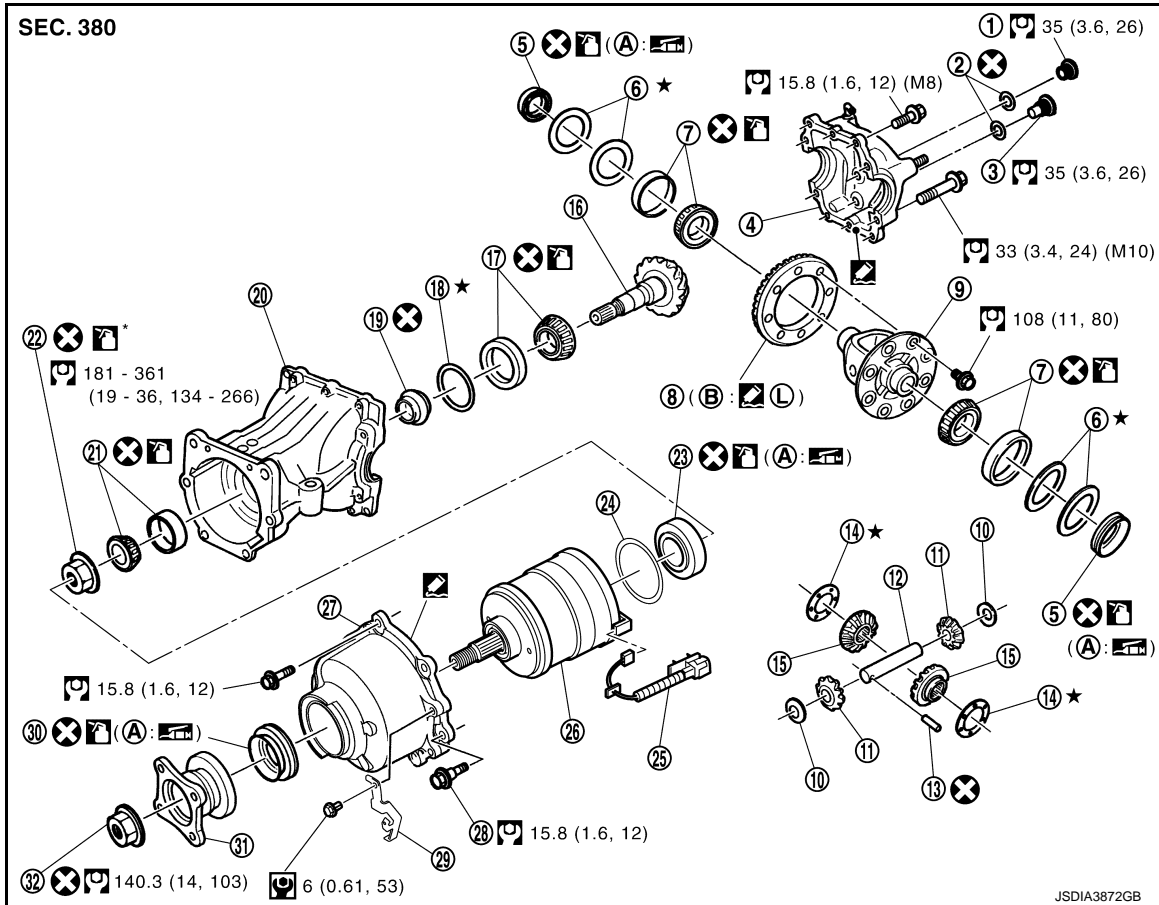

- | | | |
|-------------------------------|-----------------------------------|---------------------------------|
| 1. Filler plug | 2. Gasket | 3. Drain plug |
| 4. Rear cover | 5. Side oil seal | 6. Side bearing adjusting shim |
| 7. Side bearing | 8. Drive gear | 9. Differential case |
| 10. Pinion mate thrust washer | 11. Pinion mate gear | 12. Pinion mate shaft |
| 13. Lock pin | 14. Side gear thrust washer | 15. Side gear |
| 16. Drive pinion | 17. Pinion rear bearing | 18. Drive pinion adjusting shim |
| 19. Collapsible spacer | 20. Gear carrier | 21. Pinion front bearing |
| 22. Drive pinion nut | 23. Center oil seal* | 24. Wave spring |
| 25. AWD solenoid harness | 26. Electric controlled coupling* | 27. Coupling cover |
| 28. Reamer bolt | 29. Connector bracket | 30. Front oil seal |
| 31. Companion flange | 32. Companion flange lock nut | |

A. Oil seal lip
 B. Screw hole
 *: When replacing electric controlled coupling, replace center oil seal.

: Apply gear oil.

: Apply anti-corrosive oil.

: Apply Genuine Silicone RTV or equivalent. Refer to [GI-22, "Recommended Chemical Products and Sealants"](#).

: Apply Genuine High Strength Thread Locking Sealant or equivalent. Refer to [GI-22, "Recommended Chemical Products and Sealants"](#).

Refer to [GI-4, "Components"](#) for symbols not described above.

A
 B
 C
 DLN
 E
 F
 G
 H
 I
 J
 K
 L
 M
 N
 O
 P

DIFFERENTIAL ASSEMBLY

< UNIT DISASSEMBLY AND ASSEMBLY >

[REAR FINAL DRIVE: R145]

Disassembly

INFOID:000000008280174

1. Remove side oil seals, using a suitable tool.
CAUTION:
Never damage gear carrier and rear cover.
2. Remove rear cover mounting bolts.

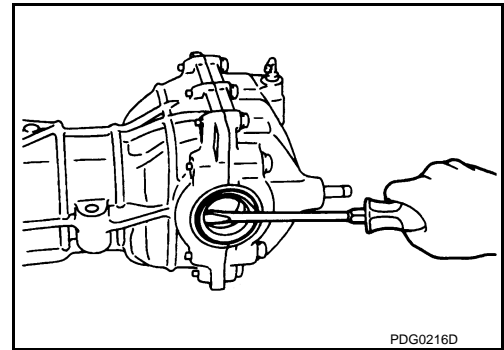

3. Set drifts [SST: KV40100610 (J-26089)] to the right and left side bearing adjusting shims individually. Press differential case assembly with side bearing to remove gear carrier assembly and rear cover assembly.

CAUTION:

The pressure shall be as low as possible to remove gear carrier assembly and rear cover assembly. The maximum pressure shall be 10 kN (1 ton, 1.1 US ton, 1.0 Imp ton).

NOTE:

Differential case assembly, side bearings, and adjusting shims are compressed and integrated in gear carrier and rear cover.

4. Remove drain plug and filler plug.
5. Remove side bearing adjusting shims and side bearing outer races.

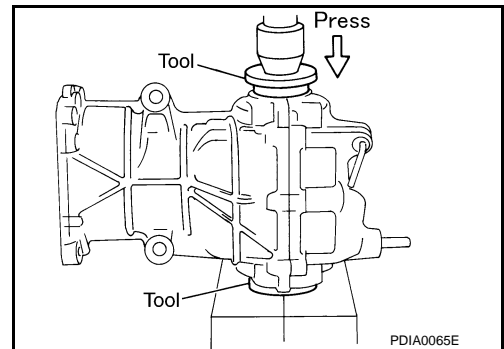

CAUTION:

Mark the side bearing adjusting shims so that the original mounting positions (right/left) can be identified later.

6. Remove drive gear mounting bolts and then remove drive gear from differential case.

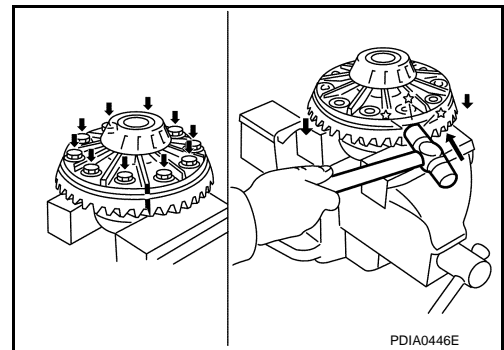

7. Remove side bearing inner races, using pullers and the drift [SST: ST33052000 (—)].

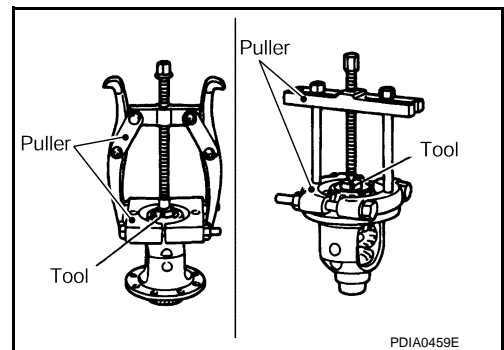

DIFFERENTIAL ASSEMBLY

< UNIT DISASSEMBLY AND ASSEMBLY >

[REAR FINAL DRIVE: R145]

8. Pull the lock pin out of pinion mate shaft, using the pin punch.

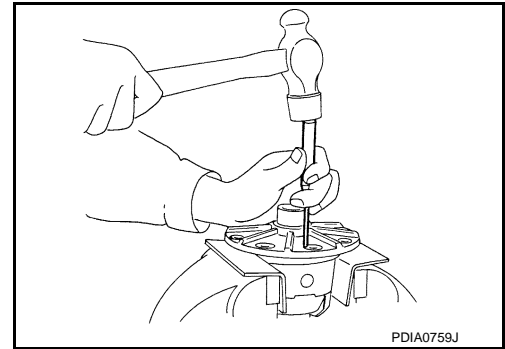

9. Remove pinion mate shaft, pinion mate gears, pinion mate thrust washers, side gears, side gear thrust washers from differential case.

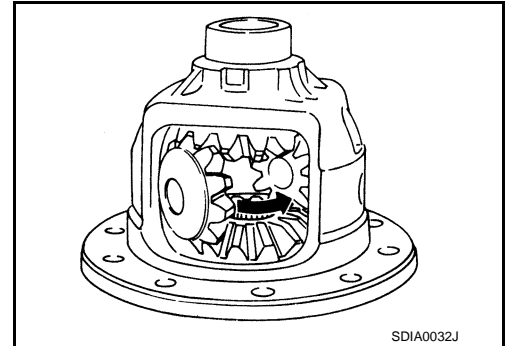

INFOID:000000008280175

Assembly

1. Install new side gear thrust washers with the same thickness as the ones installed prior to disassembly or reinstall the old ones on the side gears.
2. Install side gears and side gear thrust washers into differential case.

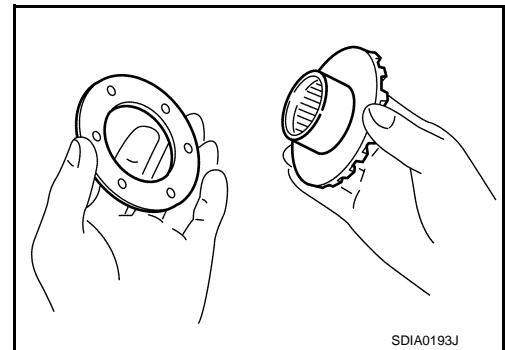

3. Align 2 pinion mate gears in diagonally opposite positions, then rotate and install them into differential case after installing pinion mate thrust washers to pinion mate gears.

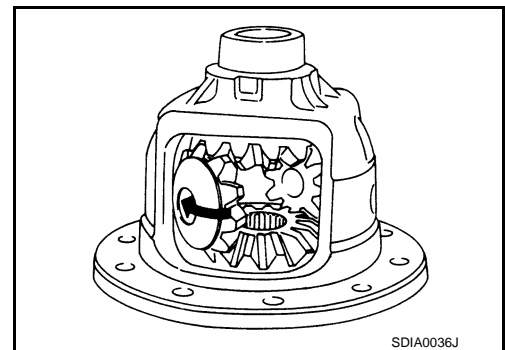

A
B
C
DLN
E
F
G
H
I
J
K
L
M
N
O
P

DIFFERENTIAL ASSEMBLY

< UNIT DISASSEMBLY AND ASSEMBLY >

[REAR FINAL DRIVE: R145]

4. Align the lock pin holes on differential case with shaft, and install pinion mate shaft.

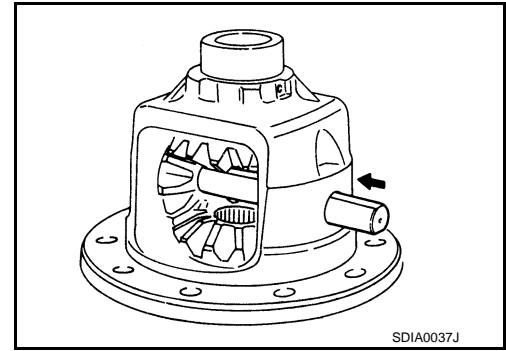

5. Measure side gear end play following the procedure below, and select the appropriate side gear thrust washers.
 - a. Place differential case straight up so that side gear to be measured comes upward.

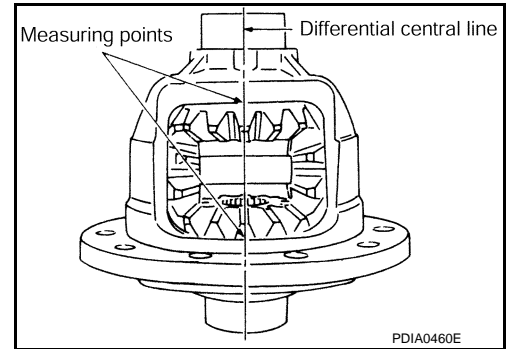

- b. Using thickness gauges, measure the clearance between side gear back and differential case at 3 different positions, while rotating side gear. Average the 3 readings, and then decide the clearance. (Measure the clearance of the other side as well.)

Standard

Side gear back clearance : Refer to [DLN-128, "Differential Side Gear Clearance"](#).

CAUTION:

To prevent side gear from tilting, insert thickness gauges with the same thickness from both sides.

- c. If the back clearance is outside the specification, use a thicker/thinner side gear thrust washer to adjust. For selecting thrust washer, refer to the latest parts information.

When the back clearance is large:

Use a thicker thrust washer.

When the back clearance is small:

Use a thinner thrust washer.

CAUTION:

Select a side gear thrust washer for right and left individually.

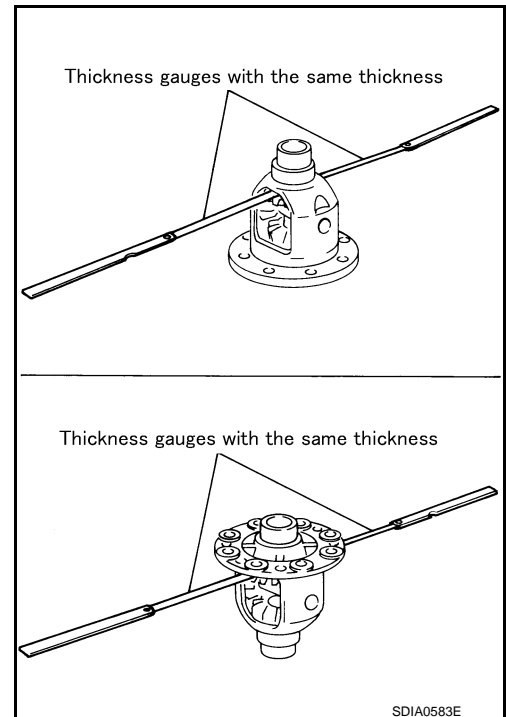

DIFFERENTIAL ASSEMBLY

< UNIT DISASSEMBLY AND ASSEMBLY >

[REAR FINAL DRIVE: R145]

6. Drive a lock pin into pinion mate shaft, using the pin punch.

CAUTION:
Never reuse lock pin.

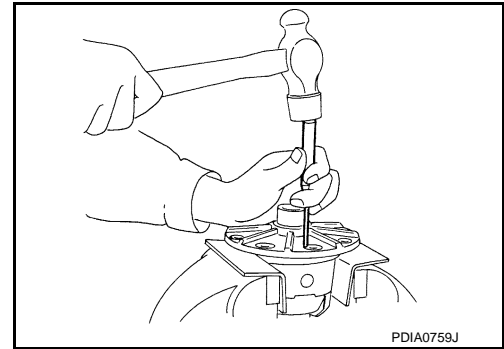

7. Press side bearing inner races to differential case, using the drift [SST: KV40105020 (—)].

CAUTION:
Never reuse side bearing inner races.

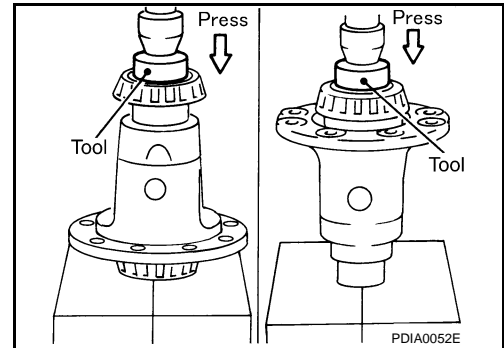

8. Apply locking sealant into the thread hole of drive gear.
- Use Genuine High Strength Thread Locking Sealant or equivalent. Refer to [GI-22. "Recommended Chemical Products and Sealants"](#).

CAUTION:
The drive gear back and threaded holes shall be cleaned and decreased sufficiently.

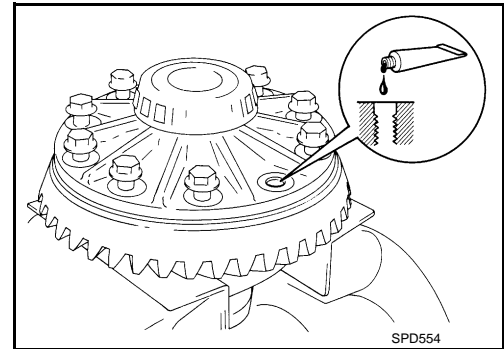

9. Install drive gear to the differential case, and then tighten to the specified torque.

10. Apply gear oil to side bearings, and install new side bearing adjusting shims (2 pieces for one side) with the same thickness as the ones installed prior to disassembly or re-install the old ones, with side bearing outer race to differential case. If side bearing adjusting shims have been already selected, use them.

CAUTION:
Never reuse side bearing outer race.

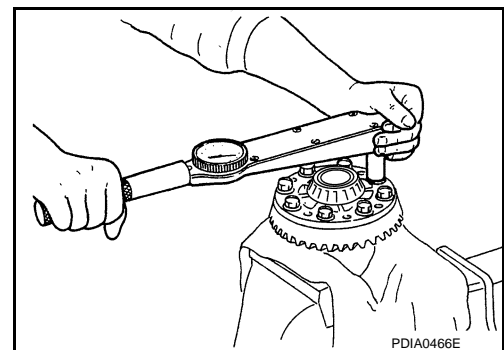

11. Set the drifts [SST: KV40100610 (J-26089)] to the right and left side bearing adjusting shims individually. Compress differential case assembly and side bearing to install gear carrier assembly to differential case assembly.

CAUTION:

- The drift shall be placed on the center of the adjusting shims.
- The pressure shall be as low as possible to install differential assembly into gear carrier assembly. The maximum pressure shall be 10 kN (1 ton, 1.1 US ton, 1.0 Imp ton).
- If the adjusting shims are installed by tapping, the gear carrier may be damaged. Avoid tapping.

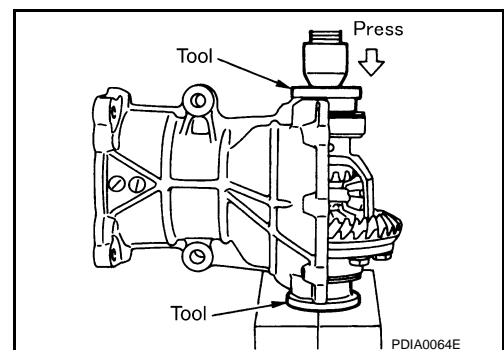

A

B

C

DLN

E

F

G

H

I

J

K

L

M

N

O

P

DIFFERENTIAL ASSEMBLY

< UNIT DISASSEMBLY AND ASSEMBLY >

[REAR FINAL DRIVE: R145]

12. Install dummy cover set, check and adjust drive gear runout, tooth contact, backlash, and total preload torque. Refer to [DLN-123, "Adjustment"](#).
13. Remove dummy cover set.
14. Apply liquid gasket to mating surface of rear cover. Overlap both ends of the bead for at least 3 mm (0.12 in).
 - Use Genuine Silicone RTV or equivalent. Refer to [GI-22, "Recommended Chemical Products and Sealants"](#).

CAUTION:

Remove old gasket adhering to the mounting surfaces. Also remove any moisture, oil, or foreign material adhering to the mounting surfaces.

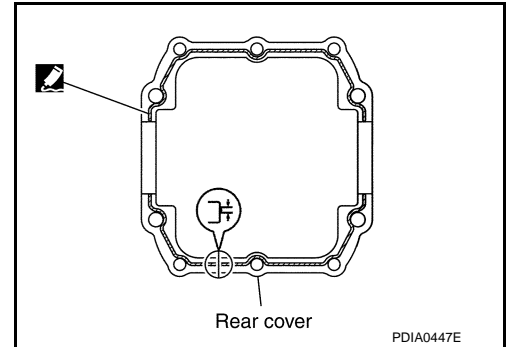

15. Set the drifts [SST: KV40100610 (J-26089)] to the right and left side bearing adjusting shims individually. Compress differential case assembly and side bearing to install rear cover.

CAUTION:

- The drift shall be placed on the center of the adjusting shims.
- The pressure shall be as low as possible to install the rear cover. The maximum pressure shall be 10 kN (1 ton, 1.0 Imp ton).
- If rear cover is forced in by tapping, rear cover may be damaged by adjusting shims. Avoid tapping.

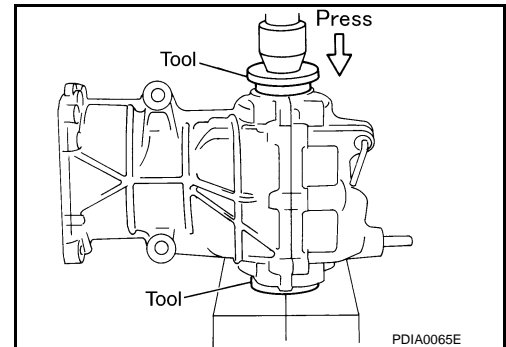

16. Tighten rear cover mounting bolts to the specified torque.
17. Using the drift [SST: KV38100200 (J-26233)], drive side oil seals until it becomes flush with the carrier end.

CAUTION:

- Never reuse oil seals.
- When installing, do not incline oil seals.
- Apply multi-purpose grease onto oil seal lips, and gear oil onto the circumference of oil seal.

18. Check total preload torque. Refer to [DLN-123, "Adjustment"](#).

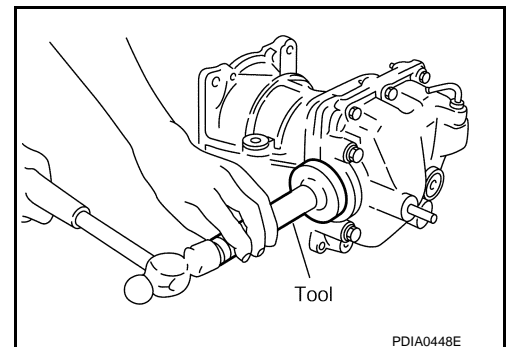

Inspection After Disassembly

INFOID:000000008280176

DRIVE GEAR AND DRIVE PINION

- Clean up the disassembled parts.
- If the gear teeth never mesh or line-up correctly, determine the cause and adjust or replace as necessary.
- If the gears are worn, cracked, damaged, pitted or chipped (by friction) noticeably, replace with new drive gear and drive pinion as a set.

BEARING

- Clean up the disassembled parts.
- If any chipped (by friction), pitted, worn, rusted or scratched marks, or unusual noise from the bearing is observed, replace as a bearing assembly (as a new set).

SIDE GEAR AND PINION MATE GEAR

- Clean up the disassembled parts.
- If any cracks or damage on the surface of the tooth is found, replace.
- If any worn or chipped mark on the contact sides of the thrust washer is found, replace.

SIDE GEAR THRUST WASHER AND PINION MATE THRUST WASHER

- Clean up the disassembled parts.
- If it is chipped (by friction), damaged, or unusually worn, replace.

DIFFERENTIAL ASSEMBLY

< UNIT DISASSEMBLY AND ASSEMBLY >

[REAR FINAL DRIVE: R145]

OIL SEAL

- Whenever disassembled, replace.
- If wear, deterioration of adherence (sealing force lips), or damage is detected on the lips, replace them.

A

DIFFERENTIAL CASE

- Clean up the disassembled parts.
- If any wear or crack on the contact sides of the differential case is found, replace.

B

COMPANION FLANGE

- Clean up the disassembled parts.
- If any chipped mark [about 0.1 mm, (0.004 in)] or other damage on the contact sides of the lips of the companion flange is found, replace.

C

DLN

E

F

G

H

I

J

K

L

M

N

O

P

DRIVE PINION

< UNIT DISASSEMBLY AND ASSEMBLY >

[REAR FINAL DRIVE: R145]

DRIVE PINION

Exploded View

INFOID:000000008280177

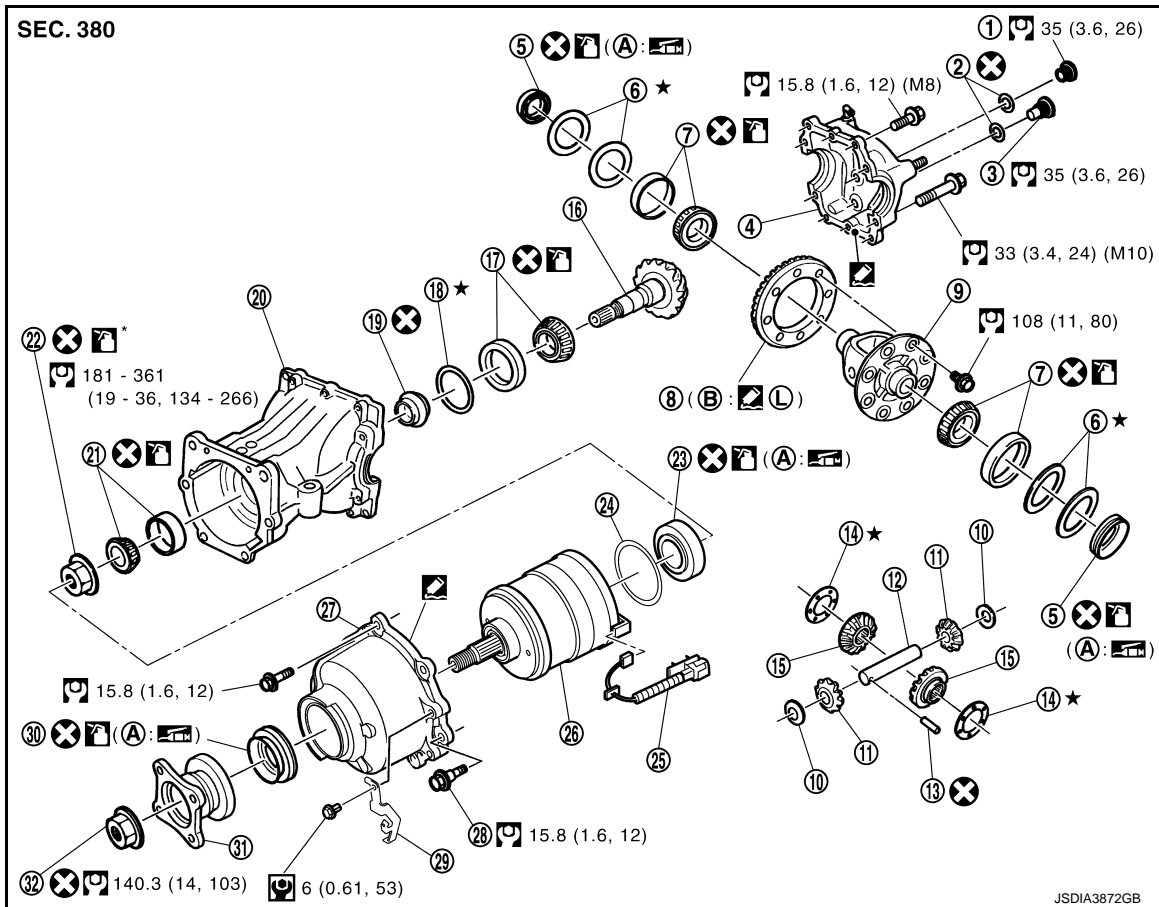

- | | | |
|-------------------------------|-----------------------------------|---------------------------------|
| 1. Filler plug | 2. Gasket | 3. Drain plug |
| 4. Rear cover | 5. Side oil seal | 6. Side bearing adjusting shim |
| 7. Side bearing | 8. Drive gear | 9. Differential case |
| 10. Pinion mate thrust washer | 11. Pinion mate gear | 12. Pinion mate shaft |
| 13. Lock pin | 14. Side gear thrust washer | 15. Side gear |
| 16. Drive pinion | 17. Pinion rear bearing | 18. Drive pinion adjusting shim |
| 19. Collapsible spacer | 20. Gear carrier | 21. Pinion front bearing |
| 22. Drive pinion nut | 23. Center oil seal* | 24. Wave spring |
| 25. AWD solenoid harness | 26. Electric controlled coupling* | 27. Coupling cover |
| 28. Reamer bolt | 29. Connector bracket | 30. Front oil seal |
| 31. Companion flange | 32. Companion flange lock nut | |
- A. Oil seal lip
B. Screw hole

*: When replacing electric controlled coupling, replace center oil seal.

: Apply gear oil.

*: Apply anti-corrosive oil.

: Apply Genuine Silicone RTV or equivalent. Refer to [GI-22, "Recommended Chemical Products and Sealants"](#).

L: Apply Genuine High Strength Thread Locking Sealant or equivalent. Refer to [GI-22, "Recommended Chemical Products and Sealants"](#).

Refer to [GI-4, "Components"](#) for symbols not described above.

DRIVE PINION

< UNIT DISASSEMBLY AND ASSEMBLY >

[REAR FINAL DRIVE: R145]

INFOID:00000000280178

Disassembly

1. Remove electric controlled coupling assembly. Refer to [DLN-107, "Disassembly"](#).
2. Remove differential case assembly. Refer to [DLN-112, "Disassembly"](#).
3. Fit drive pinion socket (A) [SST: KV38109500 (—)] onto drive pinion spline. Remove drive pinion nut, using the pinion nut wrench (B) [SST: KV38109400 (—)].

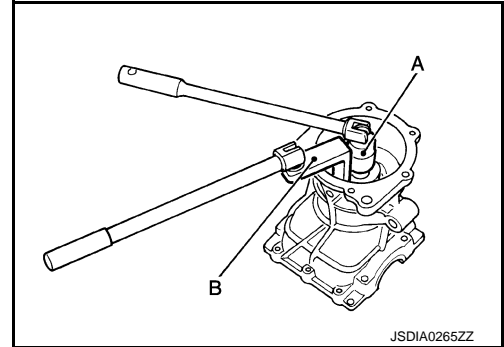

4. Press drive pinion assembly out of gear carrier.

CAUTION:
Never drop drive pinion assembly.

5. Remove pinion front bearing inner race.
6. Remove collapsible spacer.

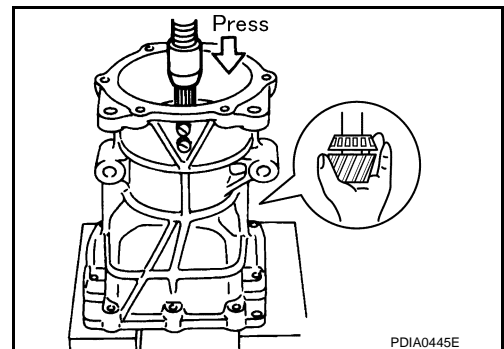

7. Remove pinion rear bearing inner race from drive pinion, using puller and bearing puller.

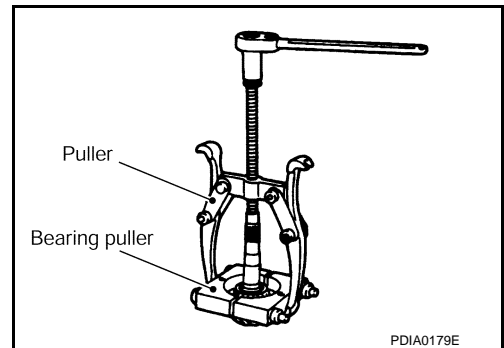

8. Using a brass rod, tap pinion front bearing outer race evenly from the 2 cutouts on gear carrier and remove pinion front bearing outer race.

CAUTION:
Never damage gear carrier.

9. Using a brass rod, tap drive pinion adjusting shim evenly from the 2 cutouts on gear carrier and remove drive pinion adjusting shim and pinion rear bearing outer race.

CAUTION:
Never damage the gear carrier.

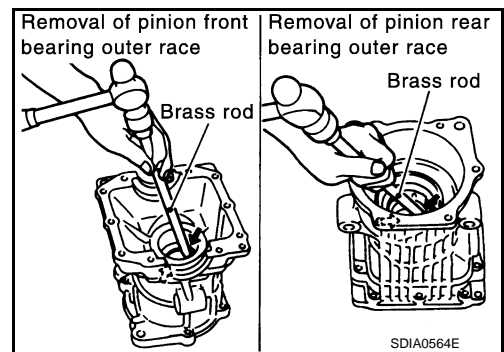

A
B
C
DLN
E
F
G
H
I
J
K
L
M
N
O
P

DRIVE PINION

< UNIT DISASSEMBLY AND ASSEMBLY >

[REAR FINAL DRIVE: R145]

INFOID:000000008280179

Assembly

1. Install a drive pinion adjusting shim of the same thickness as was installed prior to disassembly. Press pinion rear bearing outer race into gear carrier, using the drift [SST: ST1713000 (—)].

CAUTION:

- At first, using a hammer, tap bearing outer race until it becomes flush to gear carrier.
- Never reuse pinion rear bearing outer race.

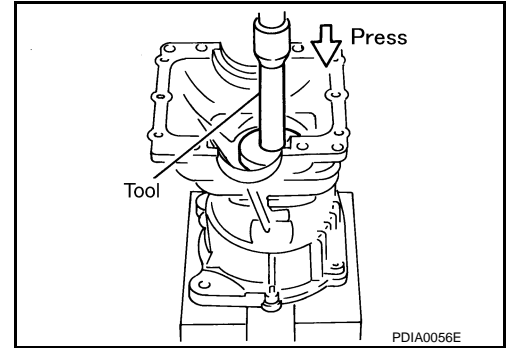

2. Press pinion front bearing outer race into gear carrier, using the drift [SST: 33230000 (J-25805-01)].

CAUTION:

- At first, using a hammer, tap bearing outer race until it becomes flush to gear carrier.
- Never reuse pinion front bearing outer race.

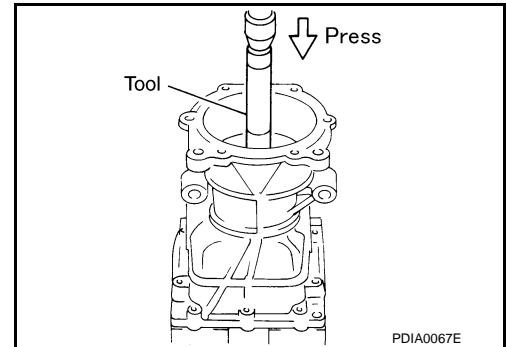

3. Press pinion rear bearing inner race to drive pinion, using the drift [SST: ST23860000 (—)].

CAUTION:

- Never reuse pinion rear bearing inner race.

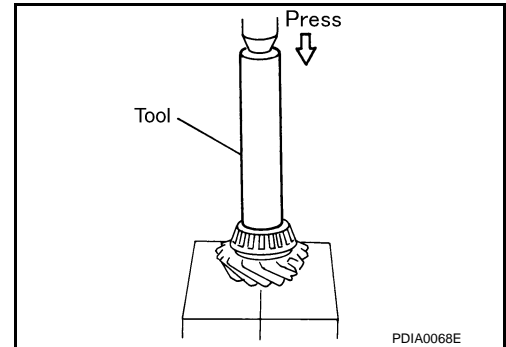

4. After checking and adjusting the tooth contact and backlash of the drive gear and drive pinion following the procedure below.

- a. Apply gear oil to the pinion rear bearing, and assemble the drive pinion to the gear carrier.

CAUTION:

- Never assemble a collapsible spacer.

- b. Apply gear oil to pinion front bearing, and assemble pinion front bearing inner race to drive pinion. Using the drifts and stand, press pinion front bearing inner race to drive pinion as far as drive pinion nut can be tightened.

A : Drift [SST: KV40100610 (J-26089)]

B : Drift [SST: ST38220000 (—)]

C : Drift [SST: ST23860000 (—)]

CAUTION:

- Never reuse pinion front bearing inner race.

- c. Temporarily tighten removed drive pinion nut to drive pinion.

NOTE:

Use removed drive pinion nut only for the preload measurement.

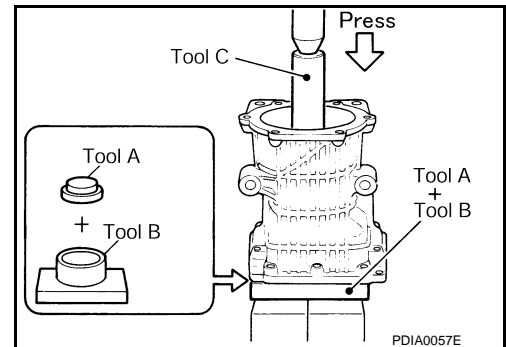

DRIVE PINION

< UNIT DISASSEMBLY AND ASSEMBLY >

[REAR FINAL DRIVE: R145]

- d. Fit the drive pinion socket (A) [SST: KV38109500 (—)] onto the drive pinion spline. Using the pinion nut wrench (B) [SST: KV38109400 (—)], tighten drive pinion nut to the specified preload torque.

C : Preload gauge [SST: ST3127S000 (J-25765-A)]

Standard

Pinion bearing preload : Refer to [DLN-128. "Pre-load Torque"](#).

CAUTION:

Drive pinion nut is tightened with no collapsible spacer. Never overtighten it. While measuring the preload, tighten it by 5° to 10°.

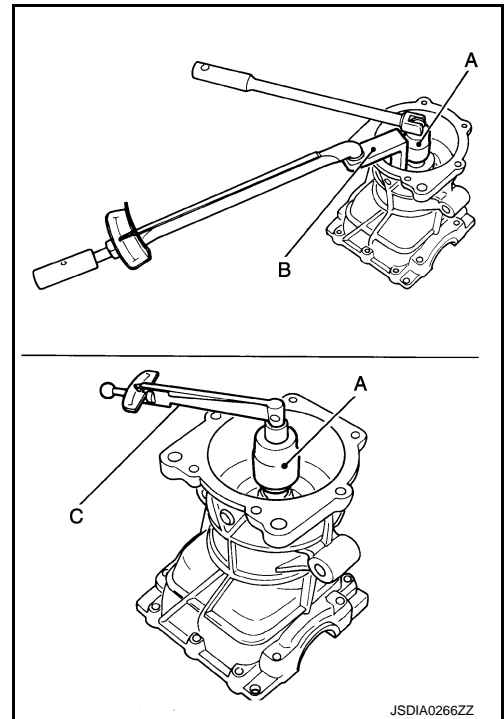

- e. Apply gear oil to side bearings, and install new side bearing adjusting shims with the same thickness or re-install the old ones to the same mounting position they were in prior to disassembly. Set the drifts [SST: KV40100610 (J-26089)] to the right and left. Install differential case assembly to gear carrier.

CAUTION:

- The drifts shall be placed on the center of the adjusting shims.
- The pressure shall be as low as possible to install gear carrier assembly to differential assembly. The maximum pressure shall be 10 kN (1 ton, 1.1 US ton, 1.0 Imp ton).
- If adjusting shims are installed by tapping, gear carrier may be damaged. Avoid tapping.

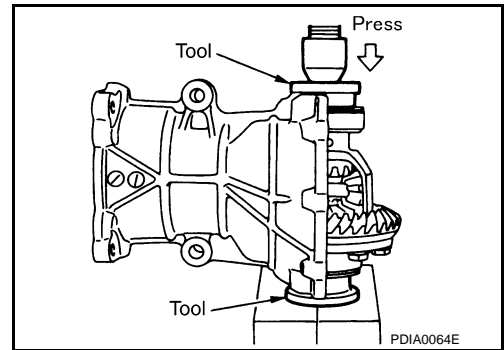

- f. Check and adjust the tooth contact. Refer to [DLN-123. "Adjustment"](#).
 g. Check and adjust the backlash. Refer to [DLN-123. "Adjustment"](#).
 h. Remove dummy cover set, and remove differential case assembly.
 i. Remove drive pinion nut and press drive pinion assembly out of gear carrier.

CAUTION:

Never drop drive pinion assembly.

- j. Remove pinion front bearing inner race.

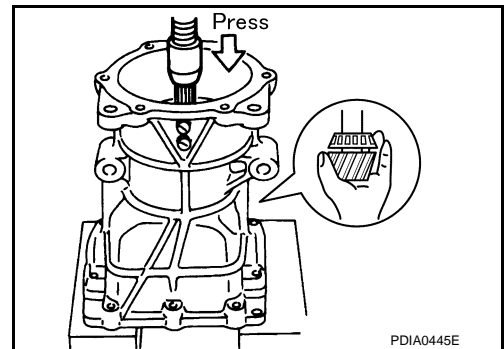

A
B
C
DLN
E
F
G
H
I
J
K
L
M
N
O
P

DRIVE PINION

< UNIT DISASSEMBLY AND ASSEMBLY >

[REAR FINAL DRIVE: R145]

5. Assemble collapsible spacer to drive pinion.

CAUTION:

- Be careful of the mounting direction of collapsible spacer.
- Never reuse collapsible spacer.

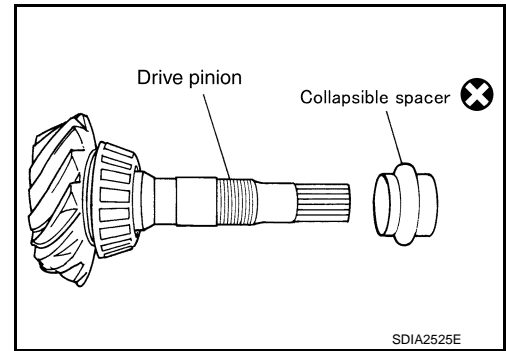

6. Apply gear oil to pinion front bearing, and assemble pinion front bearing inner race to drive pinion. Using the drifts and stand, press pinion front bearing inner race to drive pinion as far as drive pinion nut can be tightened.

- A : Drift [SST: KV40100610 (J-26089)]
 B : Drift [SST: ST38220000 (—)]
 C : Drift [SST: ST23860000 (—)]

CAUTION:

Never reuse pinion front bearing inner race.

7. Apply anti-corrosive oil to the thread and seat of drive pinion nut, and temporarily tighten drive pinion nut to drive pinion.

CAUTION:

Never reuse drive pinion nut.

8. Fit the drive pinion socket (A) [SST: KV38109500 (—)] onto the drive pinion spline. Using the pinion nut wrench (B) [SST: KV38109400 (—)], adjust the drive pinion nut tightening torque and pinion bearing preload torque.

- C : Preload gauge [SST: ST3127S000 (J-25765-A)]

Drive pinion tightening torque : Refer to [DLN-118, "Exploded View"](#).

Standard

Pinion bearing preload : Refer to [DLN-128, "Pre-load Torque"](#).

CAUTION:

- Adjust the lower limit of the drive pinion nut tightening torque first.
- If the preload torque exceeds the specified value, replace collapsible spacer and tighten it again to adjust. Never loosen drive pinion nut to adjust the preload torque.
- After adjustment, rotate drive pinion back and forth 2 to 3 times to check for unusual noise, rotation malfunction, and other malfunctions.

9. Install differential case assembly. Refer to [DLN-113, "Assembly"](#).

CAUTION:

Never install rear cover.

10. Install dummy cover set [SST: KV381086S1 (—)], and check drive gear runout, tooth contact, and backlash. Refer to [DLN-123, "Adjustment"](#).

11. Remove dummy cover set [SST: KV381086S1 (—)], then install rear cover, and side oil seal. Refer to [DLN-113, "Assembly"](#).

12. Check total preload torque. Refer to [DLN-123, "Adjustment"](#).

13. Install electric controlled coupling assembly. Refer to [DLN-107, "Assembly"](#).

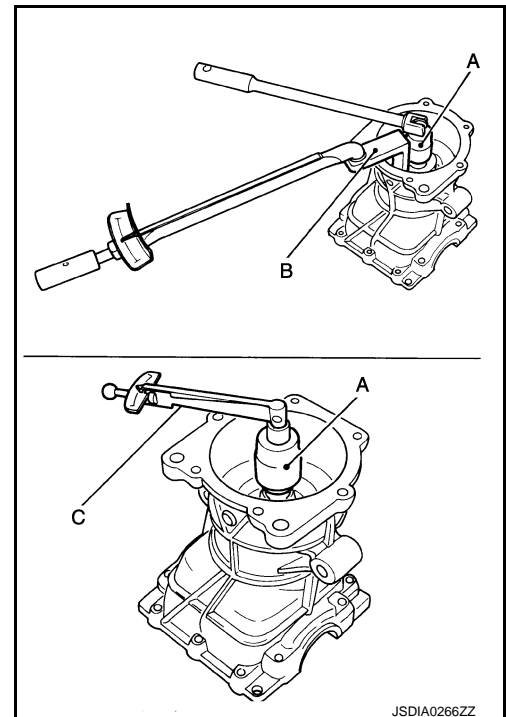
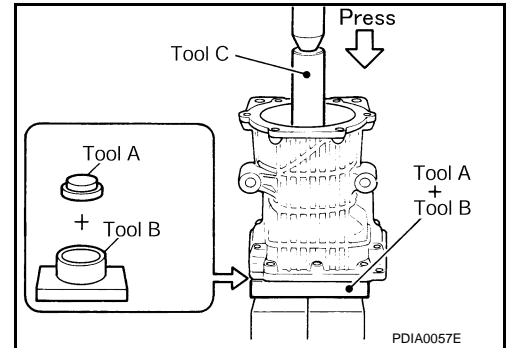

DRIVE PINION

< UNIT DISASSEMBLY AND ASSEMBLY >

[REAR FINAL DRIVE: R145]

14. Check companion flange runout. Refer to [DLN-109, "Adjustment"](#).

Adjustment

INFOID:000000008280180

TOTAL PRELOAD TORQUE

1. Remove electric controlled coupling assembly. Refer to [DLN-107, "Disassembly"](#).
2. Rotate drive pinion back and forth 2 to 3 times to check for unusual noise and rotation malfunction.
3. Rotate drive pinion at least 20 times to check for smooth operation of the bearing.
4. Fit drive pinion socket onto drive pinion spline. Measure the total preload, using the preload gauge (A) [SST: 3127S000 (J-27565-A)] and drive pinion socket (B) [SST: KV38109500 (—)].

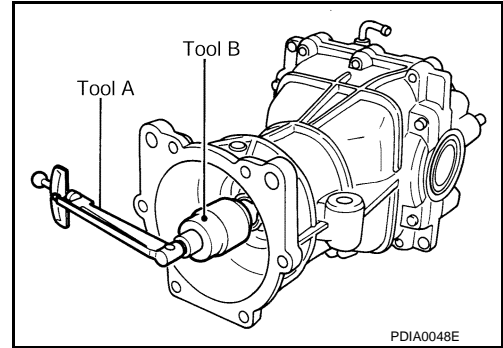

Standard

Total preload torque : Refer to [DLN-128, "Pre-load Torque"](#).

NOTE:

Total preload torque = Pinion bearing torque + Side bearing torque

- If measured value is out of the specification, disassemble it to check and adjust each part. Adjust the pinion bearing preload and side bearing preload. Adjust the pinion bearing preload first, then adjust the side bearing preload.

When the preload torque is large

On pinion bearings: Replace the collapsible spacer.

On side bearings: Use thinner side bearing adjusting shims. For selecting adjusting shim, refer to the latest parts information.

When the preload is small

On pinion bearings: Tighten the drive pinion nut.

On side bearings: Use thicker side bearing adjusting shims. For selecting adjusting shim, refer to the latest parts information.

DRIVE GEAR RUNOUT

1. Remove rear cover. Refer to [DLN-112, "Disassembly"](#).
2. Following the procedure below, install a dummy cover set [SST: KV381086S1 (—)] to gear carrier.
 - a. Set dummy cover shims [SST: KV38108630 (—)] to the right and left side bearing adjusting shims.
 - b. Temporarily tighten dummy cover [SST: KV38108610 (—)] to gear carrier.
 - c. Position dummy cover spacers [SST: KY38108621 (—)] to dummy cover [SST: 38108610 (—)].
 - d. Tighten rear cover mounting bolts to the specified torque. Refer to [DLN-118, "Exploded View"](#).
 - e. Tighten dummy cover spacer mounting bolts evenly to the specified torque.

 : 5.9 N·m (0.6 kg·m, 52 in·lb)

DRIVE PINION

< UNIT DISASSEMBLY AND ASSEMBLY >

[REAR FINAL DRIVE: R145]

3. Fit a dial indicator to the drive gear back face.
4. Rotate the drive gear to measure runout.

Limit

Drive gear back face runout : Refer to [DLN-128, "Drive Gear Runout"](#).

- If the runout is outside of the repair limit, check drive gear assembly condition; foreign material may be caught between drive gear and differential case, or differential case or drive gear may be deformed, etc.

CAUTION:

Replace drive gear and drive pinion as a set.

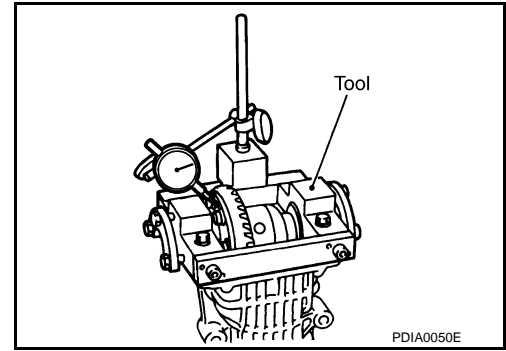

TOOTH CONTACT

1. Remove rear cover. Refer to [DLN-112, "Disassembly"](#).
2. Following the procedure below, install a dummy cover set [SST: KV381086S1 (—)] to gear carrier.
 - a. Set dummy cover shims [SST: KV38108630 (—)] to the right and left side bearing adjusting shims.
 - b. Temporarily tighten dummy cover [SST: 38108620 (—)] to gear carrier.
 - c. Position dummy cover spacers [SST: 38108621 (—)] to dummy cover [SST: 38108620 (—)].
 - d. Tighten rear cover mounting bolts to the specified torque. Refer to [DLN-118, "Exploded View"](#).
 - e. Tighten dummy cover spacer mounting bolts evenly to the specified torque.

 : 5.9 N·m (0.6 kg-m, 52 in-lb)

3. Apply red lead to drive gear.

CAUTION:

Apply red lead to both the faces of 3 to 4 gears at 4 locations evenly spaced on drive gear.

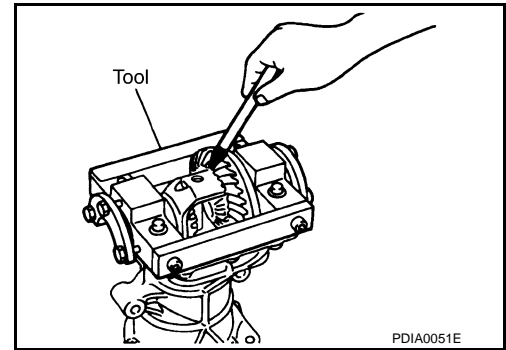

4. Rotate drive gear back and forth several times, check drive pinion gear to drive gear tooth contact.

CAUTION:

Check tooth contact on drive side and reverse side.

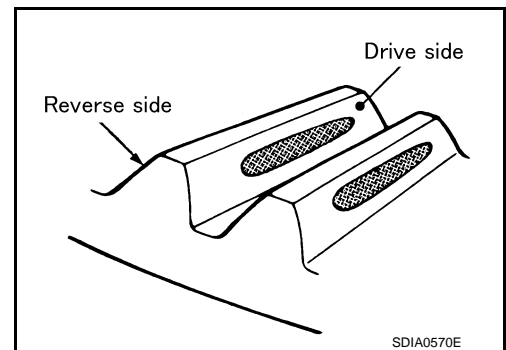

DRIVE PINION

< UNIT DISASSEMBLY AND ASSEMBLY >

[REAR FINAL DRIVE: R145]

Tooth Contact Judgment Guide

Tooth contact condition		Drive pinion adjusting shim selection value [mm (in)]	Adjustment (Yes/No)	Possible cause
Drive side	Back side			
Heel side 	Toe side 	↑ Thicker	Yes	Occurrence of noise and scoring sound in all speed ranges.
				+0.09 (+0.0035)
		↓ Thinner	No	-
		+0.03 (+0.0012)	Yes	Occurrence of noise at constant speed and decreasing speed.
		0		
		-0.03 (-0.0012)	Yes	Occurrence of noise and scoring sound in all speed ranges.
		-0.06 (-0.0024)		
		-0.09 (-0.0035)		

SDIA2549E

5. If tooth contact is improperly adjusted, follow the procedure below to adjust the pinion height (dimension X).

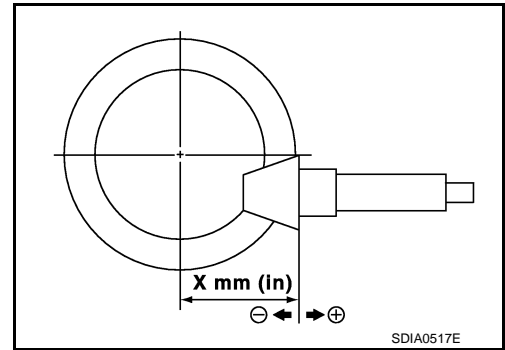

- If the tooth contact is near the face (face contact), or near the heel (heel contact), thicken drive pinion gear adjusting shim to move drive pinion closer to drive gear. For selecting adjusting shim, refer to the latest parts information.

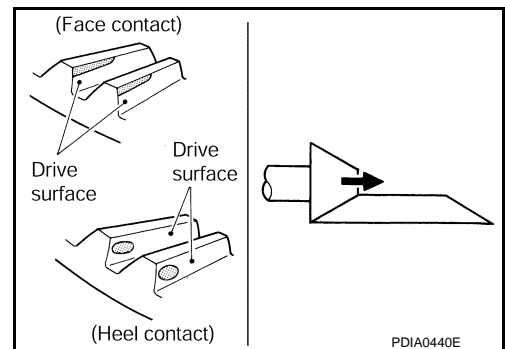

A
B
C
DLN
E
F
G
H
I
J
K
L
M
N
O
P

DRIVE PINION

< UNIT DISASSEMBLY AND ASSEMBLY >

[REAR FINAL DRIVE: R145]

- If the tooth contact is near the flank (flank contact), or near the toe (toe contact), thin drive pinion gear adjusting shim to move drive pinion farther from drive gear.
For selecting adjusting shim, refer to the latest parts information.

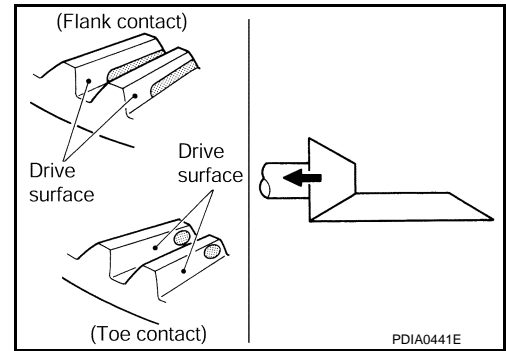

BACKLASH

1. Remove rear cover. Refer to [DLN-112, "Disassembly"](#).
2. Following the procedure below, install a dummy cover set [SST: KV381086S1 (—)] to gear carrier.
 - a. Set dummy cover shims [SST: KV38108630 (—)] to the right and left side bearing adjusting shims.
 - b. Temporarily tighten dummy cover [SST: KV38108610 (—)] to gear carrier.
 - c. Position dummy cover spacers [SST: KV38108621 (—)] to dummy cover [SST: KV38108610 (—)].
 - d. Tighten rear cover mounting bolts to the specified torque. Refer to [DLN-118, "Exploded View"](#).
 - e. Tighten dummy cover spacer mounting bolts evenly to the specified torque.

 : 5.9 N·m (0.6 kg·m, 52 in·lb)

3. Fit a dial indicator to the drive gear face to measure the backlash.

**Standard
Backlash**

: Refer to [DLN-128, "Backlash"](#).

- If the backlash is outside of the specified value, change the thickness of side bearing adjusting shims.

When the backlash is large:

Make drive gear back adjusting shims thicker, and drive gear front adjusting shims thinner. For selecting adjusting shim, refer to the latest parts information.

When the backlash is small:

Make drive gear back adjusting shims thinner, and drive gear front adjusting shims thicker. For selecting adjusting shim, refer to the latest parts information.

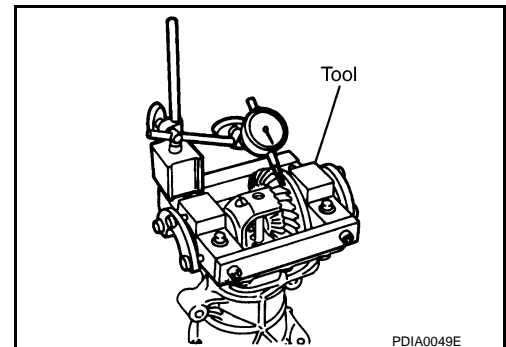

Inspection After Disassembly

INFOID:000000008280181

DRIVE GEAR AND DRIVE PINION

- Clean up the disassembled parts.
- If the gear teeth never mesh or line-up correctly, determine the cause and adjust or replace as necessary.
- If the gears are worn, cracked, damaged, pitted or chipped (by friction) noticeably, replace with new drive gear and drive pinion as a set.

BEARING

- Clean up the disassembled parts.
- If any chipped (by friction), pitted, worn, rusted or scratched marks, or unusual noise from the bearing is observed, replace as a bearing assembly (as a new set).

DRIVE PINION

< UNIT DISASSEMBLY AND ASSEMBLY >

[REAR FINAL DRIVE: R145]

SIDE GEAR AND PINION MATE GEAR

- Clean up the disassembled parts.
- If any cracks or damage on the surface of the tooth is found, replace.
- If any worn or chipped mark on the contact sides of the thrust washer is found, replace.

A

SIDE GEAR THRUST WASHER AND PINION MATE THRUST WASHER

- Clean up the disassembled parts.
- If it is chipped (by friction), damaged, or unusually worn, replace.

B

OIL SEAL

- Whenever disassembled, replace.
- If wear, deterioration of adherence (sealing force lips), or damage is detected on the lips, replace them.

C

DIFFERENTIAL CASE

- Clean up the disassembled parts.
- If any wear or crack on the contact sides of the differential case is found, replace.

E

COMPANION FLANGE

- Clean up the disassembled parts.
- If any chipped mark [about 0.1 mm, (0.004 in)] or other damage on the contact sides of the lips of the companion flange is found, replace.

F

G

H

I

J

K

L

M

N

O

P

DLN

SERVICE DATA AND SPECIFICATIONS (SDS)

< SERVICE DATA AND SPECIFICATIONS (SDS)

[REAR FINAL DRIVE: R145]

SERVICE DATA AND SPECIFICATIONS (SDS)

SERVICE DATA AND SPECIFICATIONS (SDS)

General Specification

INFOID:000000008280182

Applied model	AWD
	QR25DE
	CVT
Final drive model	R145
Gear ratio	2.466
Number of teeth (Drive gear/Drive pinion)	37/15
Oil capacity (Approx.) ℓ (US pt, Imp pt)	0.55 (1-1/8, 1)
Number of pinion gears	2
Drive pinion adjustment spacer type	Collapsible

Drive Gear Runout

INFOID:000000008280183

Unit: mm (in)

Item	Limit
Drive gear back face runout	0.05 (0.0020)

Differential Side Gear Clearance

INFOID:000000008280184

Unit: mm (in)

Item	Standard
Side gear backlash (Clearance between side gear and differential case)	0.2 (0.008) or less (Each gear should rotate smoothly without excessive resistance during differential motion.)

Preload Torque

INFOID:000000008280185

Unit: N·m (kg·m, in·lb)

Item	Standard
Pinion bearing (P1)	0.69 – 1.18 (0.07 – 0.12, 7 – 10)
Side bearing (P2)	0.64 – 0.98 (0.07 – 0.09, 6 – 8)
Side bearing to pinion bearing (Total preload) (Total preload = P1 + P2)	1.33 – 2.16 (0.14 – 0.22, 12 – 19)

Backlash

INFOID:000000008280186

Unit: mm (in)

Item	Standard
Drive gear to drive pinion gear	0.10 – 0.15 (0.0039 – 0.0059)

Companion Flange Runout

INFOID:000000008280187

Unit: mm (in)

Item	Limit
Companion flange face	0.13 (0.0051)
Inner side of the companion flange	0.19 (0.0075)