

SECTION **SN**
SONAR SYSTEM

A
B
C
D
E
F
G
H
I
J
K
L
M
N
O
P

CONTENTS

PRECAUTION	3	Work Flow	15
PRECAUTIONS	3	DTC/CIRCUIT DIAGNOSIS	17
FOR MEXICO	3	B2704 CORNER SENSOR [RL]	17
FOR MEXICO : Precaution for Supplemental Restraint System (SRS) "AIR BAG" and "SEAT BELT PRE-TENSIONER"	3	DTC Logic	17
EXCEPT FOR MEXICO	3	B2705 SENSOR HARNESS OPEN [CR-RL]	18
EXCEPT FOR MEXICO : Precaution for Supplemental Restraint System (SRS) "AIR BAG" and "SEAT BELT PRE-TENSIONER"	3	DTC Logic	18
SYSTEM DESCRIPTION	5	Diagnosis Procedure	18
COMPONENT PARTS	5	B2706 CORNER SENSOR [RR]	19
Component Parts Location	5	DTC Logic	19
Component Description	5	B2707 SENSOR HARNESS OPEN [CR-RR] ...	20
SONAR SYSTEM	6	DTC Logic	20
System Diagram	6	Diagnosis Procedure	20
System Description	6	B2708 CENTER SENSOR [BL]	21
DIAGNOSIS SYSTEM (SONAR CONTROL UNIT)	9	DTC Logic	21
CONSULT Function	9	B2709 SENSOR HARNESS OPEN [CT-BL]	22
ECU DIAGNOSIS INFORMATION	11	DTC Logic	22
SONAR CONTROL UNIT	11	Diagnosis Procedure	22
Reference Value	11	B270A CENTER SENSOR [BR]	23
Fail Safe	13	DTC Logic	23
DTC Index	13	B270B SENSOR HARNESS OPEN [CT-BR] ...	24
WIRING DIAGRAM	14	DTC Logic	24
SONAR SYSTEM	14	Diagnosis Procedure	24
Wiring Diagram	14	POWER SUPPLY AND GROUND CIRCUIT	25
BASIC INSPECTION	15	SONAR CONTROL UNIT	25
DIAGNOSIS AND REPAIR WORKFLOW	15	SONAR CONTROL UNIT : Diagnosis Procedure....	25
		R RANGE SIGNAL CIRCUIT	26
		Description	26
		Component Function Check	26
		Diagnosis Procedure	26
		SYMPTOM DIAGNOSIS	27

SN

SONAR SYSTEM SYMPTOMS	27	SONAR CONTROL UNIT	29
Symptom Table	27	Removal and Installation	29
NORMAL OPERATING CONDITION	28	SONAR SENSOR	30
Symptom Table	28	Removal and Installation	30
REMOVAL AND INSTALLATION	29		

PRECAUTIONS

< PRECAUTION >

PRECAUTION

PRECAUTIONS FOR MEXICO

FOR MEXICO : Precaution for Supplemental Restraint System (SRS) "AIR BAG" and "SEAT BELT PRE-TENSIONER"

INFOID:000000008282507

The Supplemental Restraint System such as "AIR BAG" and "SEAT BELT PRE-TENSIONER", used along with a front seat belt, helps to reduce the risk or severity of injury to the driver and front passenger for certain types of collision. Information necessary to service the system safely is included in the "SRS AIR BAG" and "SEAT BELT" of this Service Manual.

WARNING:

Always observe the following items for preventing accidental activation.

- To avoid rendering the SRS inoperative, which could increase the risk of personal injury or death in the event of a collision that would result in air bag inflation, all maintenance must be performed by an authorized NISSAN/INFINITI dealer.
- Improper maintenance, including incorrect removal and installation of the SRS, can lead to personal injury caused by unintentional activation of the system. For removal of Spiral Cable and Air Bag Module, see "SRS AIR BAG".
- Never use electrical test equipment on any circuit related to the SRS unless instructed to in this Service Manual. SRS wiring harnesses can be identified by yellow and/or orange harnesses or harness connectors.

PRECAUTIONS WHEN USING POWER TOOLS (AIR OR ELECTRIC) AND HAMMERS

WARNING:

Always observe the following items for preventing accidental activation.

- When working near the Air Bag Diagnosis Sensor Unit or other Air Bag System sensors with the ignition ON or engine running, never use air or electric power tools or strike near the sensor(s) with a hammer. Heavy vibration could activate the sensor(s) and deploy the air bag(s), possibly causing serious injury.
- When using air or electric power tools or hammers, always switch the ignition OFF, disconnect the battery, and wait at least 3 minutes before performing any service.

EXCEPT FOR MEXICO

EXCEPT FOR MEXICO : Precaution for Supplemental Restraint System (SRS) "AIR BAG" and "SEAT BELT PRE-TENSIONER"

INFOID:000000008282508

The Supplemental Restraint System such as "AIR BAG" and "SEAT BELT PRE-TENSIONER", used along with a front seat belt, helps to reduce the risk or severity of injury to the driver and front passenger for certain types of collision. This system includes seat belt switch inputs and dual stage front air bag modules. The SRS system uses the seat belt switches to determine the front air bag deployment, and may only deploy one front air bag, depending on the severity of a collision and whether the front occupants are belted or unbelted. Information necessary to service the system safely is included in the "SRS AIR BAG" and "SEAT BELT" of this Service Manual.

WARNING:

Always observe the following items for preventing accidental activation.

- To avoid rendering the SRS inoperative, which could increase the risk of personal injury or death in the event of a collision that would result in air bag inflation, all maintenance must be performed by an authorized NISSAN/INFINITI dealer.
- Improper maintenance, including incorrect removal and installation of the SRS, can lead to personal injury caused by unintentional activation of the system. For removal of Spiral Cable and Air Bag Module, see "SRS AIR BAG".
- Never use electrical test equipment on any circuit related to the SRS unless instructed to in this Service Manual. SRS wiring harnesses can be identified by yellow and/or orange harnesses or harness connectors.

PRECAUTIONS WHEN USING POWER TOOLS (AIR OR ELECTRIC) AND HAMMERS

WARNING:

A
B
C
D
E
F
G
H
I
J
K
L
M
SN
O
P

PRECAUTIONS

< PRECAUTION >

Always observe the following items for preventing accidental activation.

- **When working near the Air Bag Diagnosis Sensor Unit or other Air Bag System sensors with the ignition ON or engine running, never use air or electric power tools or strike near the sensor(s) with a hammer. Heavy vibration could activate the sensor(s) and deploy the air bag(s), possibly causing serious injury.**
- **When using air or electric power tools or hammers, always switch the ignition OFF, disconnect the battery, and wait at least 3 minutes before performing any service.**

COMPONENT PARTS

< SYSTEM DESCRIPTION >

SYSTEM DESCRIPTION

COMPONENT PARTS

Component Parts Location

INFOID:0000000008282509

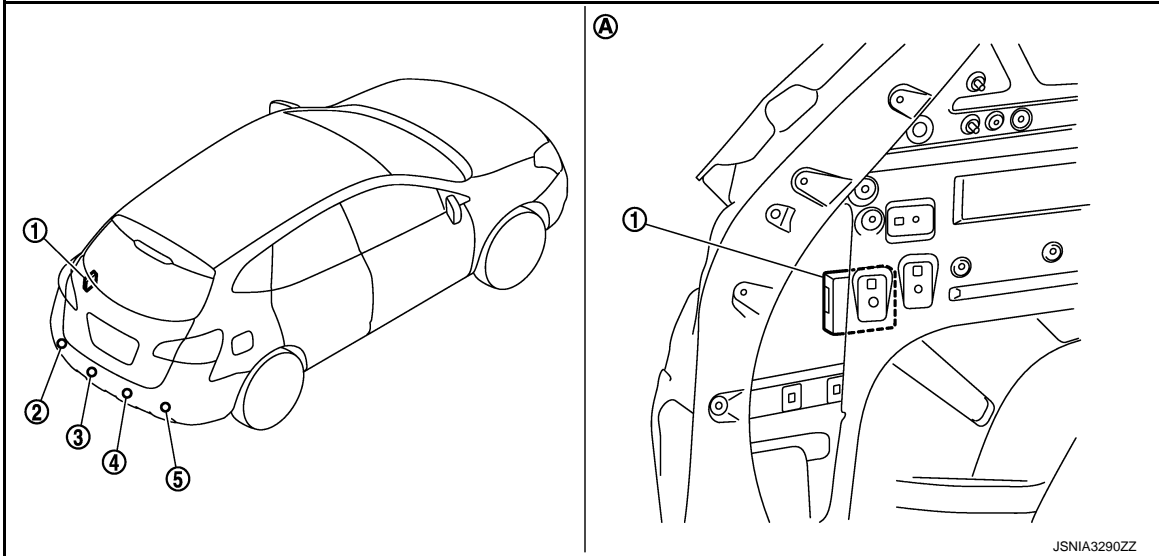

- 1. Sonar control unit
- 2. Corner sensor rear LH
- 3. Center sensor rear LH
- 4. Center sensor rear RH
- 5. Corner sensor rear RH
- A. Luggage side LH

Component Description

INFOID:0000000008282510

Component	Description
SONAR CONTROL UNIT	<ul style="list-style-type: none"> • An integrated warning buzzer sounds when receiving a sensor signal from the corner/center sensor. • When reverse signal is input, a power supply is input into sonar control unit. • The activation condition is controlled by inputting reverse signal. • Capable of system settings and trouble diagnoses with CONSULT (K-LINE).
CORNER/CENTER SENSOR	The obstacle distance is detected. The signal is transmitted to the sonar control unit.

A
B
C
D
E
F
G
H
I
J
K
L
M
N
O
P

SN

SONAR SYSTEM

< SYSTEM DESCRIPTION >

SONAR SYSTEM

System Diagram

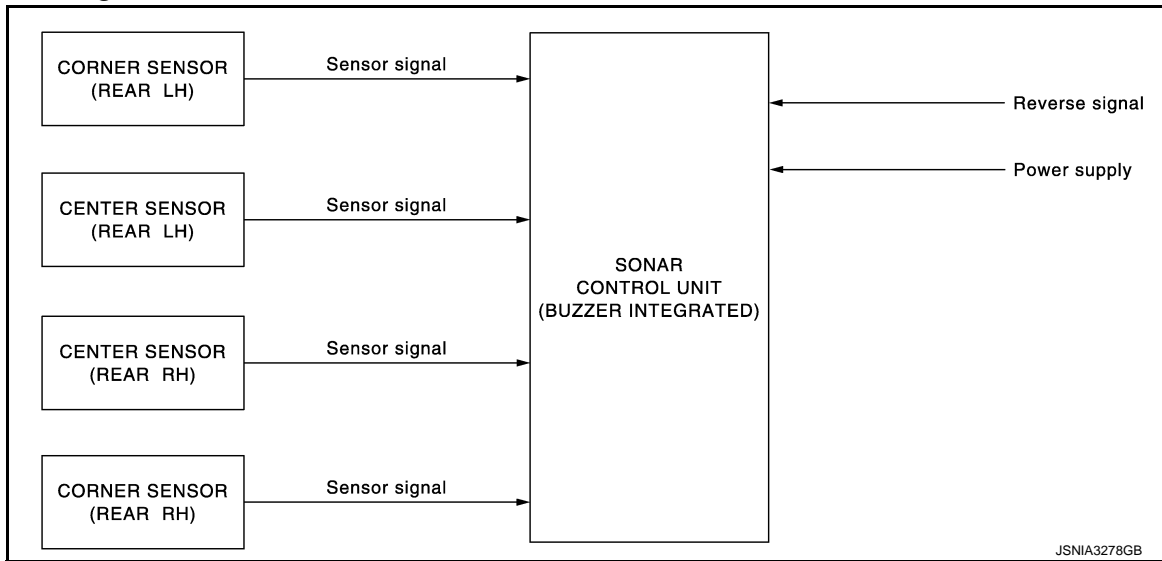

System Description

INFOID:000000008282512

- The sonar sensor installed to the rear bumper detects obstacles around the bumper.
- The distance between a bumper and obstacles is informed to the driver with different frequency of buzzer.

ACTIVATION CONDITION

The rear sensor activates and outputs the warning buzzer in the following conditions.

- Reverse signal ON
- Obstacle detection

OBSTACLE DETECTION DISTANCE

- The sonar control unit controls the obstacle detection distance. The detection distance differs between the corner sensor and the center sensor.
- The sonar control unit outputs the warning buzzer frequency at 3 levels according to the corner sensor detection condition.
- The sonar control unit outputs the warning buzzer frequency at 4 levels according to the center sensor detection condition.
- The detection condition setting is adjustable to 4 levels with CONSULT. Refer to [SN-9, "CONSULT Function"](#).
- CONSULT enables the center sensor (rear) not to detect the range of 40 cm (15.7 in) or less to prevent from the trailer hitch vehicles misdetection. Refer to [SN-9, "CONSULT Function"](#).

SONAR SYSTEM

< SYSTEM DESCRIPTION >

Obstacle detection range image

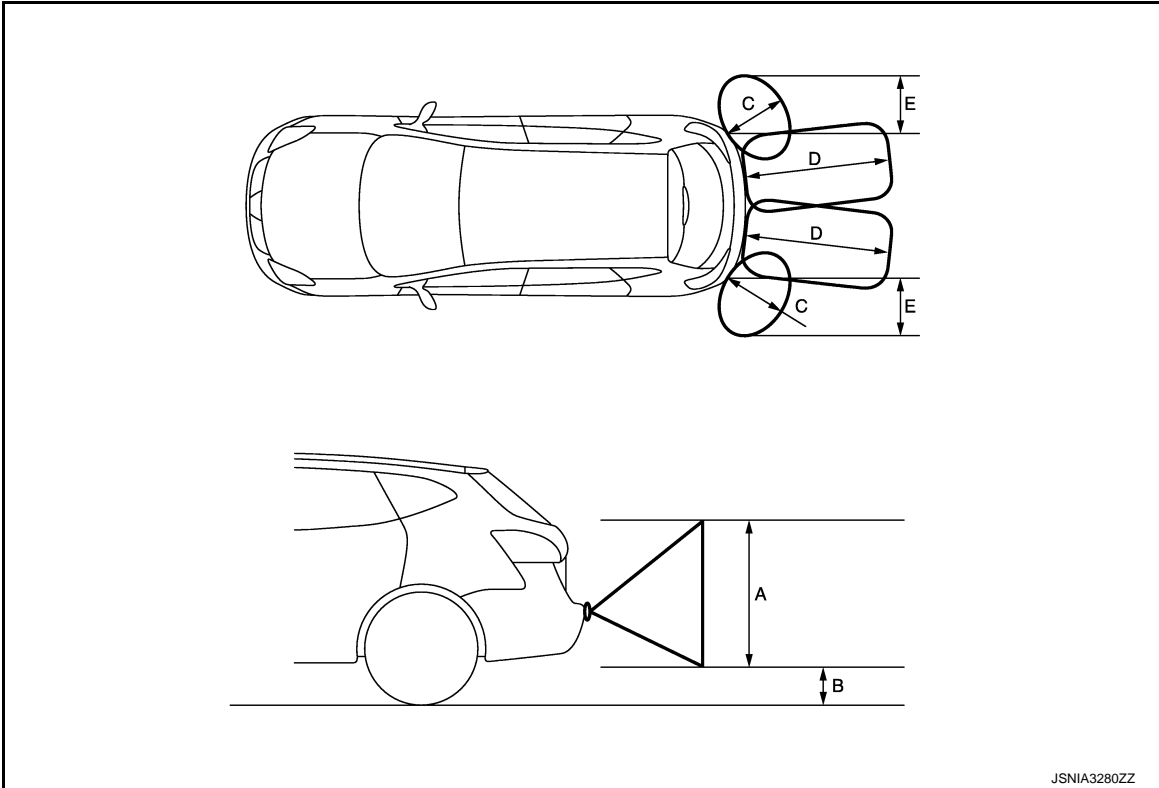

- A. Approx. 50 cm (19.6 in)
- B. Approx. 15 cm (5.9 in)
- C. Approx. 60 cm (23.6 in)
- D. Approx. 100 cm (39.3 in)
- E. Approx. 50 cm (19.6 in)

Detection distance (Default)

Warning item	Corner sensor	Center sensor
First stage warning	—	60 – 100 cm (23.6 – 39.3 in)
Second stage warning	50 – 60 cm (19.6 – 23.6 in)	50 – 60 cm (19.6 – 23.6 in)
Third stage warning	30 – 50 cm (11.8 – 19.6 in)	30 – 50 cm (11.8 – 19.6 in)
Fourth stage warning	Less than 30 cm (11.8 in)	Less than 30 cm (11.8 in)

Warning Buzzer Frequency

- The warning buzzer output frequency changes 4 levels (for center) and 3 levels (for corner) according to the detection distance.
- The nearest sensor from the detected obstacle applies the buzzer output frequency if plural sensors detect any obstacle simultaneously.

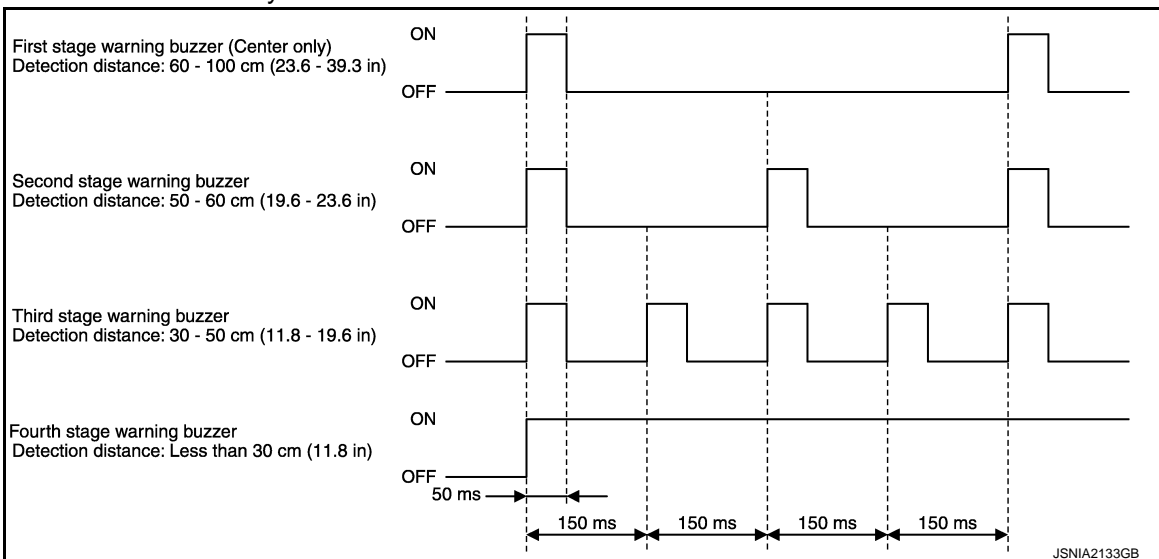

SONAR SYSTEM

< SYSTEM DESCRIPTION >

NOTE:

The warning buzzer of the corner sensor sounds as follows:

- As for the first, second, and third stages, the warning buzzer sounds 3 seconds at maximum.
- As for the fourth stage, the warning buzzer does not stop even after a lapse of 3 seconds.

DIAGNOSIS SYSTEM (SONAR CONTROL UNIT)

< SYSTEM DESCRIPTION >

DIAGNOSIS SYSTEM (SONAR CONTROL UNIT)

CONSULT Function

INFOID:000000008282513

APPLICATION ITEMS

CONSULT can display each diagnostic item using the diagnostic test modes shown as follows:

Test mode	Function
Ecu Identification	Sonar control unit part number can be read.
Self Diagnostic Results	Sonar control unit checks the conditions and displays memorized error.
Data Monitor	Sonar control unit input/output data in real time.
Work support	Changes setting of each function.
Active Test	Gives a drive signal to a load to check the operation.

ECU IDENTIFICATION

Displays the part number of the sonar control unit.

SELF-DIAGNOSTIC RESULTS

For details, refer to [SN-13, "DTC Index"](#).

DATA MONITOR

Monitor Item	Display	Description
REAR BUZZER	On	Buzzer is output condition.
	Off	Buzzer is non-output condition.
REVERSE RANGE	On	Selector lever in R position.
	Off	Other than selector lever in R position.
CR SEN [RL] CR SEN [RR]	ERROR	When a sensor is abnormal.
	LV.0	When a sensor is not detection.
	LV.2	The distance between the corner sensor and an obstacle is 50 cm (19.6 in) or more and less than 60 cm (23.6 in).
	LV.3	The distance between the corner sensor and an obstacle is 30 cm (11.8 in) or more and less than 50 cm (19.6 in).
	LV.4	The distance between corner sensor and an obstacle less than 30 cm (11.8 in).
CTR SEN [RL] CTR SEN [RR]	ERROR	When a sensor is abnormal.
	LV.0	When a sensor is not detection.
	LV.1	The distance between the center sensor and an obstacle is 60 cm (23.6 in) or more and less than 100 cm (39.3 in).
	LV.2	The distance between the center sensor and an obstacle is 50 cm (19.6 in) or more and less than 60 cm (23.6 in).
	LV.3	The distance between the center sensor and an obstacle is 30 cm (11.8 in) or more and less than 50 cm (19.6 in).
	LV.4	The distance between center sensor and an obstacle less than 30 cm (11.8 in).

ACTIVE TEST

Active test item	Function
BUZZER	This test is able to check buzzer (backward) operation.
SONAR SENSOR	This test is able to check each sonar sensor operation.

WORK SUPPORT

DIAGNOSIS SYSTEM (SONAR CONTROL UNIT)

< SYSTEM DESCRIPTION >

Work support item	Function
CORNER SEN DISTANCE SET	Corner sensor warning buzzer distance is adjustable to 4 phases.
CENTER SEN DISTANCE SET	Center sensor warning buzzer distance is adjustable to 4 phases.
TRAILER HITCH MODE	Center sensor (RR, RL) only is adjustable not to detect the distance less than 40 cm (15.7 in). NOTE: This adjustment is for preventing to miss detect the distance when installing the trailer hitch.

CORNER SEN DISTANCE SET

Corner sensor warning buzzer distance can set it to 4 phases as follows.

Warning item	FARTHER	FAR	NORMAL (Default)	NEAR
Second stage warning	70 – 80 cm (27.5 – 31.4 in)	60 – 70 cm (23.6 – 27.5 in)	50 – 60 cm (19.6 – 23.6 in)	40 – 50 cm (15.7 – 19.6 in)
Third stage warning	50 – 70 cm (19.6 – 27.5 in)	40 – 60 cm (15.7 – 23.6 in)	30 – 50 cm (11.8 – 19.6 in)	30 – 40 cm (11.8 – 15.7 in)
Fourth stage warning	Less than 50 cm (19.6 in)	Less than 40 cm (15.7 in)	Less than 30 cm (11.8 in)	Less than 30 cm (11.8 in)

The default of this model is “NORMAL”.

CENTER SEN DISTANCE SET

Center sensor warning buzzer distance can set it to 4 phases as follows.

Warning item	FARTHER	FAR	NORMAL (Default)	NEAR
First stage warning	80 – 120 cm (31.4 – 47.2 in)	70 – 110 cm (27.5 – 43.3 in)	60 – 100 cm (23.6 – 39.3 in)	50 – 90 cm (19.6 – 35.4 in)
Second stage warning	70 – 80 cm (27.5 – 31.4 in)	60 – 70 cm (23.6 – 27.5 in)	50 – 60 cm (19.6 – 23.6 in)	40 – 50 cm (15.7 – 19.6 in)
Third stage warning	50 – 70 cm (19.6 – 27.5 in)	40 – 60 cm (15.7 – 23.6 in)	30 – 50 cm (11.8 – 19.6 in)	30 – 40 cm (11.8 – 15.7 in)
Fourth stage warning	Less than 50 cm (19.6 in)	Less than 40 cm (15.7 in)	Less than 30 cm (11.8 in)	Less than 30 cm (11.8 in)

The default of this model is “NORMAL”.

TRAILER HITCH MODE

Center sensor (RR, RL) only is adjustable not to detect the distance less than 40 cm (15.7 in).

When installing the trailer hitch : ON

When not installing the trailer hitch : OFF

SONAR CONTROL UNIT

< ECU DIAGNOSIS INFORMATION >

ECU DIAGNOSIS INFORMATION

SONAR CONTROL UNIT

Reference Value

INFOID:000000008282514

VALUES ON THE DIAGNOSIS TOOL

NOTE:

The following table includes information (items) inapplicable to this vehicle. For information (items) applicable to this vehicle, refer to CONSULT display items.

Monitor Item	Display	Description
REAR BUZZER	On	Buzzer (backward) output condition.
	Off	Buzzer (backward) non-output condition.
REVERSE RANGE	On	Selector lever in R position.
	Off	Other than selector lever in R position.
CR SEN [RL]	ERROR	When a sensor is abnormal.
	LV.0	When a sensor is not detection.
	LV.2	The distance between the corner sensor and an obstacle is 50 cm (19.6 in) or more and less than 60 cm (23.6 in).
	LV.3	The distance between the corner sensor and an obstacle is 30 cm (11.8 in) or more and less than 50 cm (19.6 in).
	LV.4	The distance between corner sensor and an obstacle less than 30 cm (11.8 in).
CR SEN [RR]	ERROR	When a sensor is abnormal.
	LV.0	When a sensor is not detection.
	LV.2	The distance between the corner sensor and an obstacle is 50 cm (19.6 in) or more and less than 60 cm (23.6 in).
	LV.3	The distance between the corner sensor and an obstacle is 30 cm (11.8 in) or more and less than 50 cm (19.6 in).
	LV.4	The distance between corner sensor and an obstacle less than 30 cm (11.8 in).
CTR SEN [RL]	ERROR	When a sensor is abnormal.
	LV.0	When a sensor is not detection.
	LV.1	The distance between the center sensor and an obstacle is 60 cm (23.6 in) or more and less than 100 cm (39.3 in).
	LV.2	The distance between the center sensor and an obstacle is 50 cm (19.6 in) or more and less than 60 cm (23.6 in).
	LV.3	The distance between the center sensor and an obstacle is 30 cm (11.8 in) or more and less than 50 cm (19.6 in).
CTR SEN [RR]	ERROR	When a sensor is abnormal.
	LV.0	When a sensor is not detection.
	LV.1	The distance between the center sensor and an obstacle is 60 cm (23.6 in) or more and less than 100 cm (39.3 in).
	LV.2	The distance between the center sensor and an obstacle is 50 cm (19.6 in) or more and less than 60 cm (23.6 in).
	LV.3	The distance between the center sensor and an obstacle is 30 cm (11.8 in) or more and less than 50 cm (19.6 in).
	LV.4	The distance between center sensor and an obstacle less than 30 cm (11.8 in).

SONAR CONTROL UNIT

< ECU DIAGNOSIS INFORMATION >

TERMINAL LAYOUT

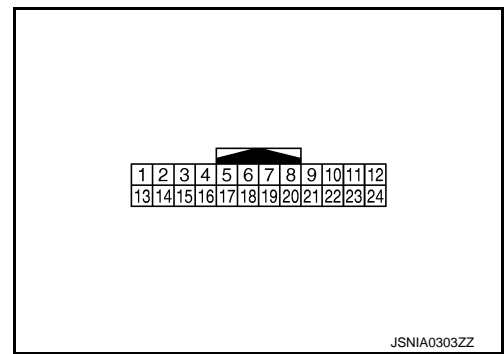

PHYSICAL VALUES

Terminal No. (Wire color)		Description		Condition		Reference value (Approx.)
+	-	Signal name	Input/ Output			
3 (L)	12 (W)	Center sensor signal LH	Input	Ignition switch ON	—	<p style="text-align: right;">SKIB8942E</p>
4 (BR)	12 (W)	Center sensor signal RH	Input	Ignition switch ON	—	<p style="text-align: right;">SKIB8942E</p>
5 (Y)	12 (W)	Corner sensor signal LH	Input	Ignition switch ON	—	<p style="text-align: right;">SKIB8942E</p>
6 (G)	12 (W)	Corner sensor signal RH	Input	Ignition switch ON	—	<p style="text-align: right;">SKIB8942E</p>
13 (G)	Ground	Ignition power supply	Input	Ignition switch ON	—	Battery voltage
17 (SB)	Ground	Reverse signal	Input	Ignition switch ON	Shift the selector lever to "R" position.	Battery voltage
					Shift the selector lever oth- er than "R" position.	0 V

SONAR CONTROL UNIT

< ECU DIAGNOSIS INFORMATION >

Terminal No. (Wire color)		Description		Condition		Reference value (Approx.)
+	-	Signal name	Input/ Output			
18 (P)	—	K-line (CONSULT)	Input/ Output	—	—	—
24 (B)	Ground	Ground	—	Ignition switch ON	—	0 V

Fail Safe

INFOID:000000008282515

The sonar control unit detects sonar sensor malfunction and activates warning chime approximately 3 seconds when the selector lever is in the reverse position.

DTC Index

INFOID:000000008282516

DTC	Display item	Malfunction is detected when...	Refer to
B2704	CORNER SENSOR [RL] [B2704]	Corner sensor rear LH is malfunctioning.	SN-17
B2705	SENSOR HARNESS OPEN [CR-RL] [B2705]	Corner sensor rear LH harness circuit is open.	SN-18
B2706	CORNER SENSOR [RR] [B2706]	Corner sensor rear RH is malfunctioning.	SN-19
B2707	SENSOR HARNESS OPEN [CR-RR] [B2707]	Corner sensor rear RH harness circuit is open.	SN-20
B2708	CENTER SENSOR [BL] [B2708]	Center sensor rear LH is malfunctioning.	SN-21
B2709	SENSOR HARNESS OPEN [CT-BL] [B2709]	Center sensor rear LH harness circuit is open.	SN-22
B270A	CENTER SENSOR [BR] [B270A]	Center sensor rear RH is malfunctioning.	SN-23
B270B	SENSOR HARNESS OPEN [CT-BR] [B270B]	Center sensor rear RH harness circuit is open.	SN-24

NOTE:

“TIME” means the following.

- 0: Means detected malfunction at present. (From malfunction detection to turning ignition switch OFF)
- 1–39: Means detected malfunction in past.

A
B
C
D
E
F
G
H
I
J
K
L
M
N
O
P

SN

SONAR SYSTEM

< WIRING DIAGRAM >

WIRING DIAGRAM

SONAR SYSTEM

Wiring Diagram

INFOID:000000008282517

For connector terminal arrangements, harness layouts, and alphabets in a  (option abbreviation; if not described in wiring diagram), refer to [GI-12. "Connector Information"](#).

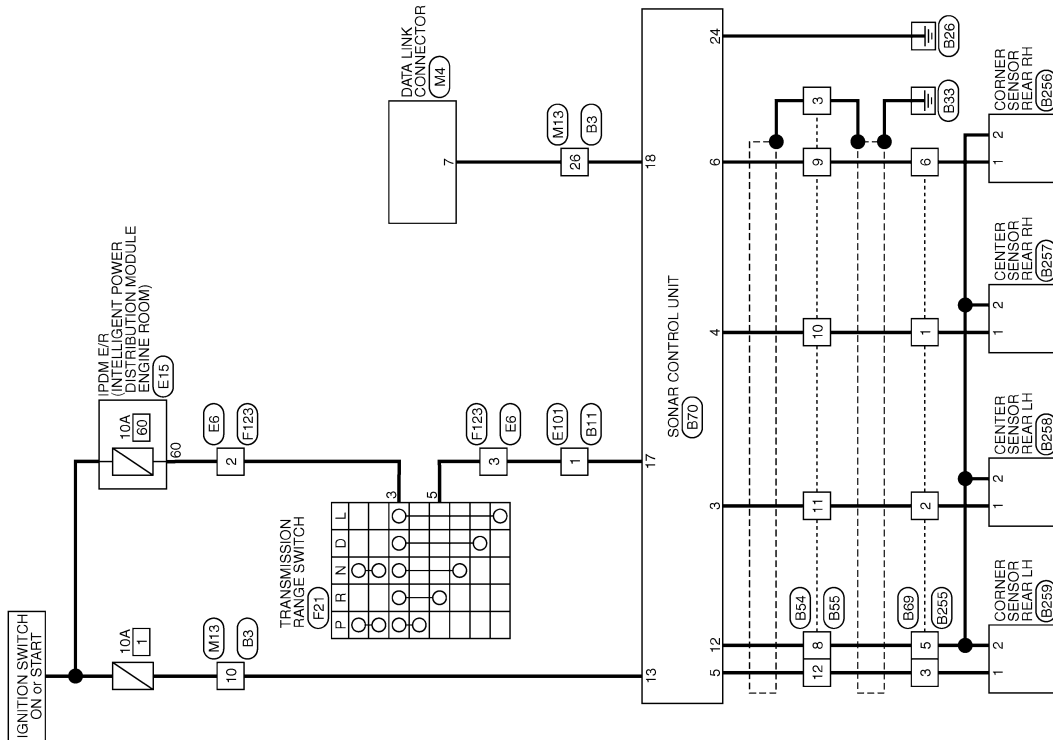

SONAR SYSTEM

2012/05/23

JRNWC2398GB

DIAGNOSIS AND REPAIR WORKFLOW

< BASIC INSPECTION >

BASIC INSPECTION

DIAGNOSIS AND REPAIR WORKFLOW

Work Flow

INFOID:000000008282518

OVERALL SEQUENCE

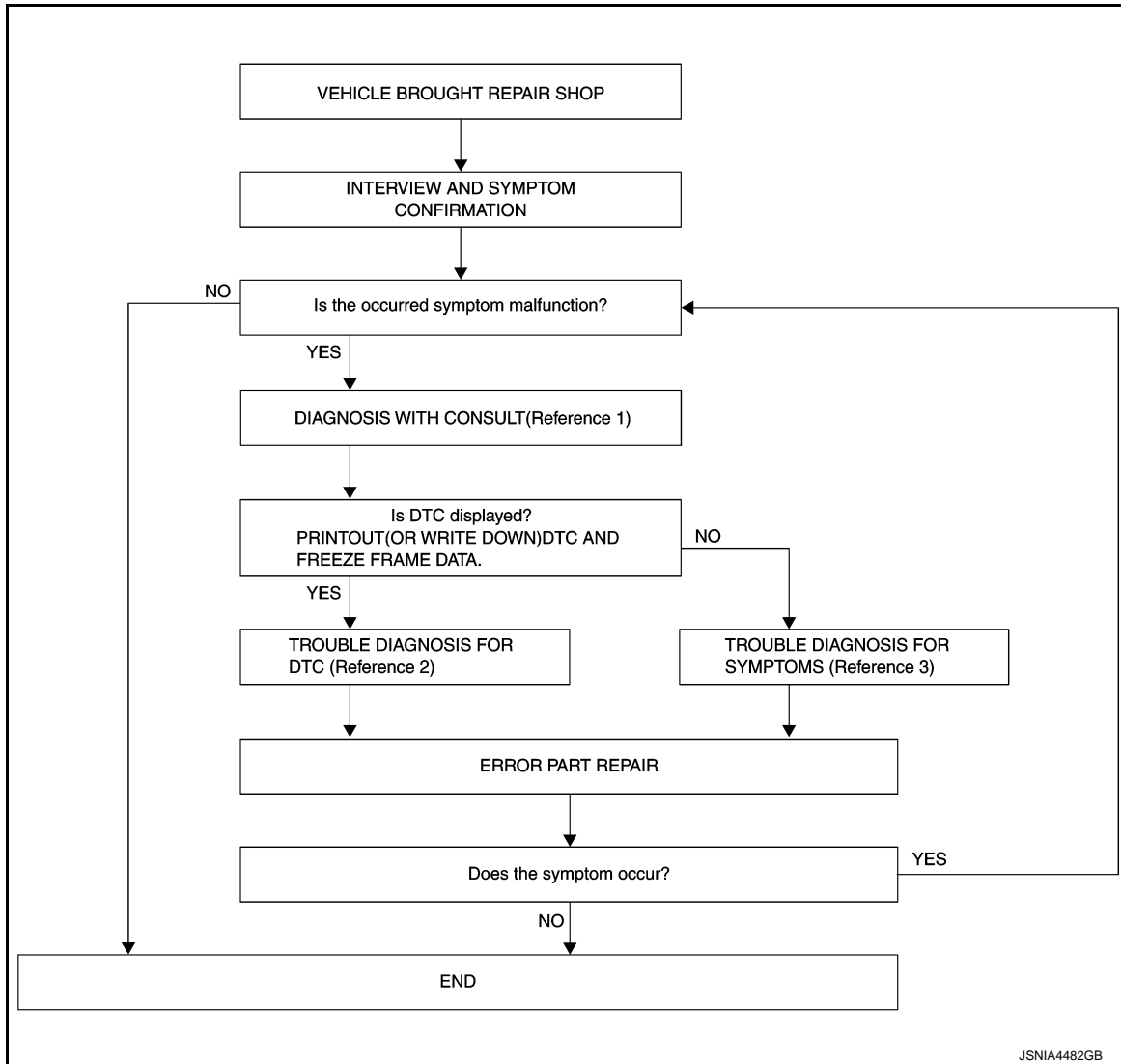

- Reference 1... Refer to [SN-9, "CONSULT Function"](#).
- Reference 2... Refer to [SN-13, "DTC Index"](#).
- Reference 3... Refer to [SN-27, "Symptom Table"](#).

DETAILED FLOW

1. INTERVIEW AND SYMPTOM CONFIRMATION

Check the malfunction symptoms by performing the following items.

- Interview the customer to obtain the malfunction information (conditions and environment when the malfunction occurred).
- Check if mud, or other foreign objects are not adhering to the sonar sensor.
- Check if there is no deformation, scratches, or other damage to the sonar sensor.
- Check if water has not accumulated in the sonar sensor.
- Check the symptom.

Is the occurred symptom malfunction?

YES >> GO TO 2.

DIAGNOSIS AND REPAIR WORKFLOW

< BASIC INSPECTION >

NO >> INSPECTION END

2. DIAGNOSIS WITH CONSULT

1. Connect CONSULT and perform a self-diagnosis for "SONAR". Refer to [SN-9. "CONSULT Function"](#).
2. When DTC is detected, follow the instructions below:
 - Record DTC and Freeze Frame Data.

Is DTC displayed?

YES >> GO TO 3.

NO >> GO TO 4.

3. TROUBLE DIAGNOSIS FOR DTC

1. Check the DTC indicated in the self-diagnosis results.
2. Perform the relevant diagnosis referring to the DTC Index. Refer to [SN-13. "DTC Index"](#).

>> GO TO 5.

4. TROUBLE DIAGNOSIS FOR SYMPTOMS

Perform the relevant diagnosis referring to the diagnosis chart by symptom. Refer to [SN-27. "Symptom Table"](#).

>> GO TO 5.

5. ERROR PART REPAIR

1. Repair or replace the identified malfunctioning parts.
2. Perform a self-diagnosis for "SONAR" with CONSULT.
3. Check that the symptom does not occur.

Does the symptom occur?

YES >> GO TO 1.

NO >> INSPECTION END

B2704 CORNER SENSOR [RL]

< DTC/CIRCUIT DIAGNOSIS >

DTC/CIRCUIT DIAGNOSIS

B2704 CORNER SENSOR [RL]

DTC Logic

INFOID:000000008282519

DTC DETECTION LOGIC

DTC No.	CONSULT indication	DTC detection condition	Troubleshooting
B2704	CORNER SENSOR [RL]	Corner sensor rear LH is malfunctioning.	Replace corner sensor rear LH. Refer to SN-30, "Removal and Installation" .

A
B
C
D
E
F
G
H
I
J
K
L
M
O
P

SN

B2705 SENSOR HARNESS OPEN [CR-RL]

< DTC/CIRCUIT DIAGNOSIS >

B2705 SENSOR HARNESS OPEN [CR-RL]

DTC Logic

INFOID:000000008282520

DTC DETECTION LOGIC

DTC No.	CONSULT indication	DTC detection condition	Troubleshooting
B2705	SENSOR HARNESS OPEN [CR-RL]	Corner sensor rear LH harness circuit is open.	Check corner sensor rear LH circuit.

Diagnosis Procedure

INFOID:000000008282521

1. CHECK HARNESS CORNER SENSOR REAR LH SIGNAL CIRCUIT

1. Turn ignition switch OFF.
2. Disconnect sonar control unit connector and corner sensor rear LH connector.
3. Check continuity between sonar control unit harness connector and corner sensor rear LH harness connector.

Sonar control unit		Corner sensor rear LH		Continuity
Connector	Terminal	Connector	Terminal	
B70	5	B259	1	Existed

4. Check continuity between sonar control unit harness connector and ground.

Sonar control unit		Ground	Continuity
Connector	Terminal		
B70	5		Not existed

Is the inspection result normal?

- YES >> GO TO 2.
NO >> Repair harness or connector.

2. CHECK HARNESS CORNER SENSOR REAR LH GROUND CIRCUIT

Check continuity between sonar control unit harness connector and corner sensor rear LH harness connector.

Sonar control unit		Corner sensor rear LH		Continuity
Connector	Terminal	Connector	Terminal	
B70	12	B259	2	Existed

Is the inspection result normal?

- YES >> Replace sonar control unit. Refer to [SN-29. "Removal and Installation"](#).
NO >> Repair harness or connector.

B2706 CORNER SENSOR [RR]

< DTC/CIRCUIT DIAGNOSIS >

B2706 CORNER SENSOR [RR]

DTC Logic

INFOID:000000008282522

DTC DETECTION LOGIC

DTC No.	CONSULT indication	DTC detection condition	Troubleshooting
B2706	CORNER SENSOR [RR]	Corner sensor rear RH is malfunctioning.	Replace corner sensor rear RH. Refer to SN-30, "Removal and Installation" .

A
B
C
D
E
F
G
H
I
J
K
L
M
O
P

SN

B2707 SENSOR HARNESS OPEN [CR-RR]

< DTC/CIRCUIT DIAGNOSIS >

B2707 SENSOR HARNESS OPEN [CR-RR]

DTC Logic

INFOID:000000008282523

DTC DETECTION LOGIC

DTC No.	CONSULT indication	DTC detection condition	Troubleshooting
B2707	SENSOR HARNESS OPEN [CR-RR]	Corner sensor rear RH harness circuit is open.	Check corner sensor rear RH circuit.

Diagnosis Procedure

INFOID:000000008282524

1. CHECK HARNESS CORNER SENSOR REAR RH SIGNAL CIRCUIT

1. Turn ignition switch OFF.
2. Disconnect sonar control unit connector and corner sensor rear RH connector.
3. Check continuity between sonar control unit harness connector and corner sensor rear RH harness connector.

Sonar control unit		Corner sensor rear RH		Continuity
Connector	Terminal	Connector	Terminal	
B70	6	B256	1	Existed

4. Check continuity between sonar control unit harness connector and ground.

Sonar control unit		Ground	Continuity
Connector	Terminal		
B70	6		Not existed

Is the inspection result normal?

- YES >> GO TO 2.
NO >> Repair harness or connector.

2. CHECK HARNESS CORNER SENSOR REAR RH GROUND CIRCUIT

Check continuity between sonar control unit harness connector and corner sensor rear RH harness connector.

Sonar control unit		Corner sensor rear RH		Continuity
Connector	Terminal	Connector	Terminal	
B70	12	B256	2	Existed

Is the inspection result normal?

- YES >> Replace sonar control unit. Refer to [SN-29. "Removal and Installation"](#).
NO >> Repair harness or connector.

B2708 CENTER SENSOR [BL]

< DTC/CIRCUIT DIAGNOSIS >

B2708 CENTER SENSOR [BL]

DTC Logic

INFOID:000000008282525

DTC DETECTION LOGIC

DTC No.	CONSULT indication	DTC detection condition	Troubleshooting
B2708	CENTER SENSOR [BL]	Center sensor rear LH is malfunctioning.	Replace center sensor rear LH. Refer to SN-30, "Removal and Installation" .

A
B
C
D
E
F
G
H
I
J
K
L
M
O
P

SN

B2709 SENSOR HARNESS OPEN [CT-BL]

< DTC/CIRCUIT DIAGNOSIS >

B2709 SENSOR HARNESS OPEN [CT-BL]

DTC Logic

INFOID:000000008282526

DTC DETECTION LOGIC

DTC No.	CONSULT indication	DTC detection condition	Troubleshooting
B2709	SENSOR HARNESS OPEN [CT-BL]	Center sensor rear LH harness circuit is open.	Check center sensor rear LH circuit.

Diagnosis Procedure

INFOID:000000008282527

1. CHECK HARNESS CENTER SENSOR REAR LH SIGNAL CIRCUIT

1. Turn ignition switch OFF.
2. Disconnect sonar control unit connector and center sensor rear LH connector.
3. Check continuity between sonar control unit harness connector and center sensor rear LH harness connector.

Sonar control unit		Center sensor rear LH		Continuity
Connector	Terminal	Connector	Terminal	
B70	3	B258	1	Existed

4. Check continuity between sonar control unit harness connector and ground.

Sonar control unit		Ground	Continuity
Connector	Terminal		
B70	3		Not existed

Is the inspection result normal?

- YES >> GO TO 2.
NO >> Repair harness or connector.

2. CHECK HARNESS CENTER SENSOR REAR LH GROUND CIRCUIT

Check continuity between sonar control unit harness connector and center sensor rear LH harness connector.

Sonar control unit		Center sensor rear LH		Continuity
Connector	Terminal	Connector	Terminal	
B70	12	B258	2	Existed

Is the inspection result normal?

- YES >> Replace sonar control unit. Refer to [SN-29. "Removal and Installation"](#).
NO >> Repair harness or connector.

B270A CENTER SENSOR [BR]

< DTC/CIRCUIT DIAGNOSIS >

B270A CENTER SENSOR [BR]

DTC Logic

INFOID:000000008282528

DTC DETECTION LOGIC

DTC No.	CONSULT indication	DTC detection condition	Troubleshooting
B270A	CENTER SENSOR [BR]	Center sensor rear RH is malfunctioning.	Replace center sensor rear RH. Refer to SN-30, "Removal and Installation" .

A
B
C
D
E
F
G
H
I
J
K
L
M
O
P

SN

B270B SENSOR HARNESS OPEN [CT-BR]

< DTC/CIRCUIT DIAGNOSIS >

B270B SENSOR HARNESS OPEN [CT-BR]

DTC Logic

INFOID:000000008282529

DTC DETECTION LOGIC

DTC No.	CONSULT indication	DTC detection condition	Troubleshooting
B270B	SENSOR HARNESS OPEN [CT-BR]	Center sensor rear RH harness circuit is open.	Check center sensor rear RH circuit.

Diagnosis Procedure

INFOID:000000008282530

1. CHECK HARNESS CENTER SENSOR REAR RH SIGNAL CIRCUIT

1. Turn ignition switch OFF.
2. Disconnect sonar control unit connector and center sensor rear RH connector.
3. Check continuity between sonar control unit harness connector and center sensor rear RH harness connector.

Sonar control unit		Center sensor rear RH		Continuity
Connector	Terminal	Connector	Terminal	
B70	4	B257	1	Existed

4. Check continuity between sonar control unit harness connector and ground.

Sonar control unit		Ground	Continuity
Connector	Terminal		
B70	4		Not existed

Is the inspection result normal?

- YES >> GO TO 2.
NO >> Repair harness or connector.

2. CHECK HARNESS CENTER SENSOR REAR RH GROUND CIRCUIT

Check continuity between sonar control unit harness connector and center sensor rear RH harness connector.

Sonar control unit		Center sensor rear RH		Continuity
Connector	Terminal	Connector	Terminal	
B70	12	B257	2	Existed

Is the inspection result normal?

- YES >> Replace sonar control unit. Refer to [SN-29. "Removal and Installation"](#).
NO >> Repair harness or connector.

POWER SUPPLY AND GROUND CIRCUIT

< DTC/CIRCUIT DIAGNOSIS >

POWER SUPPLY AND GROUND CIRCUIT SONAR CONTROL UNIT

SONAR CONTROL UNIT : Diagnosis Procedure

INFOID:000000008282531

1. CHECK FUSE

Check for blown fuses.

Power source	Fuse No.
Ignition switch ON or START	1

Is the inspection result normal?

YES >> GO TO 2.

NO >> Be sure to eliminate the cause of malfunction before installing new fuse.

2. CHECK POWER SUPPLY CIRCUIT

1. Turn ignition switch ON.
2. Check voltage between sonar control unit harness connector and ground.

Signal name	Connector No.	Terminal No.	Ignition switch position	Value
Power supply	B70	13	ON	Battery voltage

Is the inspection result normal?

YES >> GO TO 3.

NO >> Repair or replace sonar control unit power supply circuit.

3. CHECK GROUND CIRCUIT

1. Turn ignition switch OFF.
2. Disconnect sonar control unit connector.
3. Check continuity between sonar control unit harness connector and ground.

Signal name	Connector No.	Terminal No.	Ignition switch position	Continuity
Ground	B70	24	OFF	Existed

Is the inspection result normal?

YES >> INSPECTION END

NO >> Repair or replace sonar control unit ground circuit.

A
B
C
D
E
F
G
H
I
J
K
L
M
O
P

SN

R RANGE SIGNAL CIRCUIT

< DTC/CIRCUIT DIAGNOSIS >

R RANGE SIGNAL CIRCUIT

Description

INFOID:000000008282532

The sonar control unit turns the sonar system activation ON when inputting the reverse signal.

Component Function Check

INFOID:000000008282533

1. SONAR CONTROL UNIT DATA MONITOR INSPECTION

Check "REVERSE RANGE" with "DATA MONITOR" of "SONAR".

REVERSE RANGE

Vehicle condition	Indication
Selector lever is in R position	: On
Selector lever is in other than R position	: Off

>> INSPECTION END

Diagnosis Procedure

INFOID:000000008282534

1. CHECK R RANGE SIGNAL

1. Turn ignition switch ON.
2. Check voltage between sonar control unit harness connector and ground.

(+) Sonar control unit		(-)	Condition	Voltage (Approx.)
Connector	Terminal			
B70	17	Ground	Selector lever is in R position.	12.0 V
			Selector lever is in other than R position.	0 V

Is the inspection result normal?

- YES >> INSPECTION END
NO >> Repair harness or connector.

SONAR SYSTEM SYMPTOMS

< SYMPTOM DIAGNOSIS >

SYMPTOM DIAGNOSIS

SONAR SYSTEM SYMPTOMS

Symptom Table

INFOID:000000008282535

Symptom	Check item	Diagnosis method
All sonar sensors do not activate.	Buzzer beeps when indicating "On" on "BUZZER" screen of the ACTIVE TEST.	Check reverse signal for sonar control unit. Refer to SN-26, "Diagnosis Procedure" .
	Buzzer does not beeps when indicating "On" on "BUZZER" screen of the ACTIVE TEST.	Replace sonar control unit. Refer to SN-29, "Removal and Installation" .
	Sonar is not displayed on CONSULT menu items.	Check sonar control unit power supply and ground circuit. Refer to SN-25, "SONAR CONTROL UNIT : Diagnosis Procedure" .
Any sonar sensor does not activate.	—	Perform "Self Diagnostic Result" of "SONAR" with CONSULT. Refer to SN-9, "CONSULT Function" .

A
B
C
D
E
F
G
H
I
J
K
L
M
N
O
P

SN

NORMAL OPERATING CONDITION

< SYMPTOM DIAGNOSIS >

NORMAL OPERATING CONDITION

Symptom Table

INFOID:000000008714278

Symptom	Possible cause
Unstable object detection	<ul style="list-style-type: none">• The degree of surface roughness of a stone or gravel is large.• When used in poor weather conditions, such as heavy snow/rain or strong wind.• When subjected to an ultrasonic noise generated from exhaust muffler or brakes.• When left standing under a boiling sun or in cold climate.• When the surface of the sensor is frozen or covered with snow/dirt/moisture.• When a retrofitted xenon lamp, lighting license plate, or harness is close to the sensor body or sensor harness.• When subjected to loop coil noises generated from a vehicle detector placed at an intersection or coin parking area.
Object undetectable	<ul style="list-style-type: none">• Air-containing objects, such as cloth, cotton, glass wool, dust, and snow.• Thin objects, such as rope, chain, and wire.• Smooth-faced objects placed in a slanting direction.• Fast-moving small animals.• A corner of an angular object. <p>NOTE: If the sensor detection part is scratched, obstacles cannot be detected.</p>

SONAR CONTROL UNIT

< REMOVAL AND INSTALLATION >

REMOVAL AND INSTALLATION

SONAR CONTROL UNIT

Removal and Installation

INFOID:000000008282536

REMOVAL

1. Remove luggage side lower finisher LH. Refer to [INT-31, "Exploded View"](#).
2. Remove sonar control unit screw, then disconnect sonar control unit connector and remove the sonar control unit.

INSTALLATION

Install in the reverse order of removal.

A

B

C

D

E

F

G

H

I

J

K

L

M

SN

O

P

SONAR SENSOR

< REMOVAL AND INSTALLATION >

SONAR SENSOR

Removal and Installation

INFOID:000000008282537

REMOVAL

1. Remove the bumper fascia assembly. Refer to [EXT-16. "Exploded View"](#).
2. Disconnect sonar sensor connector.
3. Press out the sonar sensor from back of bumper fascia assembly to remove sonar sensor.

INSTALLATION

Install in the reverse order of removal.

CAUTION:

The connector direction is shown below:

- The connectors must be faced left ward when viewed from the vehicle rear side.
- within $\pm 10^\circ$ from the horizontal position when assembling the bumper. Please refer below drawing for connector direction of the sensor. (About all sensors)

A : Horizontal position

a : 10°

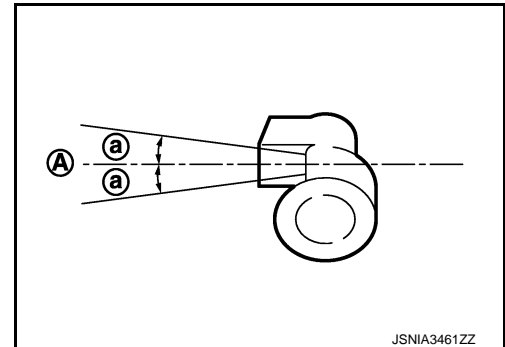

JSNIA3461ZZ