

WT
SECTION
ROAD WHEELS & TIRES

A
B
C
D

WT

CONTENTS

<p>BASIC INSPECTION 3</p> <p>DIAGNOSIS AND REPAIR WORKFLOW 3</p> <p style="padding-left: 20px;">Work Flow3</p> <p>ADDITIONAL SERVICE WHEN REPLACING BCM 5</p> <p style="padding-left: 20px;">Description5</p> <p style="padding-left: 20px;">Work Procedure5</p> <p>TIRE PRESSURE SENSOR WAKE UP OPERATION 6</p> <p style="padding-left: 20px;">Description6</p> <p style="padding-left: 20px;">Work Procedure6</p> <p>ID REGISTRATION 7</p> <p style="padding-left: 20px;">Description7</p> <p style="padding-left: 20px;">Work Procedure7</p> <p>SYSTEM DESCRIPTION 9</p> <p>SYSTEM 9</p> <p style="padding-left: 20px;">System Diagram9</p> <p style="padding-left: 20px;">System Description9</p> <p style="padding-left: 20px;">Component Parts Location 11</p> <p style="padding-left: 20px;">Component Description 11</p> <p>DIAGNOSIS SYSTEM (BCM)12</p> <p>COMMON ITEM12</p> <p style="padding-left: 20px;">COMMON ITEM : CONSULT Function (BCM - COMMON ITEM) 12</p> <p>AIR PRESSURE MONITOR12</p> <p style="padding-left: 20px;">AIR PRESSURE MONITOR : CONSULT Function (BCM - AIR PRESSURE MONITOR) 13</p> <p>DTC/CIRCUIT DIAGNOSIS14</p> <p>C1704, C1705, C1706, C1707 LOW TIRE PRESSURE14</p> <p style="padding-left: 20px;">Description 14</p> <p style="padding-left: 20px;">DTC Logic 14</p>	<p style="padding-left: 20px;">Diagnosis Procedure14</p> <p>C1708, C1709, C1710, C1711 TIRE PRESSURE SENSOR16</p> <p style="padding-left: 20px;">DTC Logic16</p> <p style="padding-left: 20px;">Diagnosis Procedure16</p> <p>C1716, C1717, C1718, C1719 TIRE PRESSURE SENSOR19</p> <p style="padding-left: 20px;">Description19</p> <p style="padding-left: 20px;">DTC Logic19</p> <p style="padding-left: 20px;">Diagnosis Procedure19</p> <p>C1729 VEHICLE SPEED SIGNAL21</p> <p style="padding-left: 20px;">Description21</p> <p style="padding-left: 20px;">DTC Logic21</p> <p style="padding-left: 20px;">Diagnosis Procedure21</p> <p>C1735 IGNITION SIGNAL22</p> <p style="padding-left: 20px;">Description22</p> <p style="padding-left: 20px;">DTC Logic22</p> <p style="padding-left: 20px;">Diagnosis Procedure22</p> <p>REMOTE KEYLESS ENTRY RECEIVER23</p> <p style="padding-left: 20px;">Description23</p> <p style="padding-left: 20px;">Component Function Check23</p> <p style="padding-left: 20px;">Diagnosis Procedure23</p> <p>LOW TIRE PRESSURE WARNING LAMP25</p> <p style="padding-left: 20px;">Description25</p> <p style="padding-left: 20px;">Component Function Check25</p> <p style="padding-left: 20px;">Diagnosis Procedure25</p> <p>POWER SUPPLY AND GROUND CIRCUIT26</p> <p style="padding-left: 20px;">Diagnosis Procedure26</p> <p>ECU DIAGNOSIS INFORMATION27</p> <p>BCM27</p> <p style="padding-left: 20px;">List of ECU Reference27</p> <p>WIRING DIAGRAM28</p>
--	---

F
G
H
I
J
K
L
M
N
O
P

TIRE PRESSURE MONITORING SYSTEM	28	FOR USA AND CANADA : Service Notice and Precautions	38
Wiring Diagram	28		
SYMPTOM DIAGNOSIS	29	FOR MEXICO	38
TPMS	29	FOR MEXICO : Precaution for Supplemental Re- straint System (SRS) "AIR BAG" and "SEAT BELT PRE-TENSIONER"	38
Symptom Table	29	FOR MEXICO : Service Notice and Precautions ...	39
LOW TIRE PRESSURE WARNING LAMP DOES NOT TURN ON	32	PREPARATION	40
Description	32	PREPARATION	40
Diagnosis Procedure	32	Special Service Tools	40
LOW TIRE PRESSURE WARNING LAMP DOES NOT TURN OFF	33	Commercial Service Tools	40
Description	33	PERIODIC MAINTENANCE	41
Diagnosis Procedure	33	ROAD WHEEL	41
LOW TIRE PRESSURE WARNING LAMP BLINKS	35	Adjustment	41
Description	35	REMOVAL AND INSTALLATION	44
Diagnosis Procedure	35	ROAD WHEEL TIRE ASSEMBLY	44
ID REGISTRATION CANNOT BE COMPLET- ED	36	Exploded View	44
Description	36	Removal and Installation	44
Diagnosis Procedure	36	Inspection	44
NOISE, VIBRATION AND HARSHNESS (NVH) TROUBLESHOOTING	37	TIRE PRESSURE SENSOR	46
NVH Troubleshooting Chart	37	Exploded View	46
PRECAUTION	38	Removal and Installation	46
PRECAUTIONS	38	TIRE PRESSURE RECEIVER	49
FOR USA AND CANADA	38	Removal and Installation	49
FOR USA AND CANADA : Precaution for Supple- mental Restraint System (SRS) "AIR BAG" and "SEAT BELT PRE-TENSIONER"	38	SERVICE DATA AND SPECIFICATIONS (SDS)	50
		SERVICE DATA AND SPECIFICATIONS (SDS)	50
		Road Wheel	50
		Tire Air Pressure	50

DIAGNOSIS AND REPAIR WORKFLOW

< BASIC INSPECTION >

BASIC INSPECTION

DIAGNOSIS AND REPAIR WORKFLOW

Work Flow

INFOID:000000008279670

DETAILED FLOW

1. COLLECT THE INFORMATION FROM THE CUSTOMER

It is also important to clarify customer concerns before starting the inspection. Reproduce the symptom, and understand it fully. Interview the customer about the concerns carefully. In some cases, it is necessary to check the symptoms by driving the vehicle with the customer.

CAUTION:

Customers are not professionals. Never assume “maybe the customer means...” or “maybe the customer mentioned this symptom.”

>> GO TO 2.

2. BASIC INSPECTION

1. Turn the ignition switch ON.

CAUTION:

Never start the engine.

2. Check the tire pressure for all wheels and adjust to the specified value. Refer to [WT-50, "Tire Air Pressure"](#).

Is the inspection result normal?

YES >> GO TO 3.

NO >> Inspect or repair the tires or wheels.

3. CHECK LOW TIRE PRESSURE WARNING LAMP

Check low tire pressure warning lamp display.

Does not low tire pressure warning lamp turn OFF?

YES >> GO TO 4.

NO >> INSPECTION END

4. CRUISE TEST

Start the engine and drive the vehicle.

>> GO TO 5.

5. PERFORM SELF-DIAGNOSIS

 **With CONSULT**

Perform “SELF-DIAG RESULTS”.

Is any DTC detected?

YES >> Record or print DTC and freeze frame data (FFD). GO TO 7.

NO >> GO TO 6.

6. CHECK SYMPTOM

Perform trouble diagnosis for the applicable symptom. Refer to [WT-29, "Symptom Table"](#).

Is the cause of the malfunction detected?

YES >> GO TO 8.

NO >> GO TO 10.

7. CIRCUIT DIAGNOSIS

Inspect the malfunctioning system indicated by the DTC code that is detected during self-diagnosis. Refer to [BCS-61, "DTC Index"](#).

>> GO TO 8.

DIAGNOSIS AND REPAIR WORKFLOW

< BASIC INSPECTION >

8. REPAIR WORK

Repair or replace the malfunctioning part.

>> GO TO 9.

9. PERFORM SELF-DIAGNOSIS

1. Select "SELF-DIAG RESULTS" in "AIR PRESSURE MONITOR" of "BCM".
2. Touch "ERASE" on CONSULT screen to erase memory of the BCM.
3. Drive the vehicle.
4. Perform "SELF-DIAG RESULTS" in "AIR PRESSURE MONITOR" of "BCM".

Is any DTC detected?

- YES >> GO TO 7.
NO >> GO TO 10.

10. FINAL CHECK

1. Perform a cruise test.
2. Check that the low tire pressure warning lamp turn OFF.

Dose the tire pressure warning lamp turn OFF?

- YES >> INSPECTION END
NO >> GO TO 2.

ADDITIONAL SERVICE WHEN REPLACING BCM

< BASIC INSPECTION >

ADDITIONAL SERVICE WHEN REPLACING BCM

Description

INFOID:000000008279671

When replacing BCM, transmitter ID registration is required.

Work Procedure

INFOID:000000008279672

1. PERFORM TRANSMITTER ID REGISTRATION

Perform transmitter ID registration.

>> Refer to [WT-7. "Work Procedure"](#).

A

B

C

D

WT

F

G

H

I

J

K

L

M

N

O

P

TIRE PRESSURE SENSOR WAKE UP OPERATION

< BASIC INSPECTION >

TIRE PRESSURE SENSOR WAKE UP OPERATION

Description

INFOID:000000008279673

This procedure must be done after replacement of a tire pressure sensor, BCM, or rotation of wheels.

Work Procedure

INFOID:000000008279674

1. TIRE PRESSURE SENSOR WAKE-UP PROCEDURE

1. Turn the ignition switch ON.

CAUTION:

Never start the engine.

NOTE:

The position of an inactive tire pressure sensor can be identified by checking the blinking timing of the low tire pressure warning lamp.

Low tire pressure warning lamp blinking timing		Activation tire position
ON OFF		Front LH
ON OFF		Front RH
ON OFF		Rear RH
ON OFF		Rear LH
ON OFF		All tires

JPEIC0089GB

2. Contact the activation tool (J-45295) (1) to the side of the tire at the location to the tire pressure sensor.
3. Press and hold the activation tool button while pushing the tool to the tire surface. (approximately for 5 seconds)

CAUTION:

Perform the wake-up procedure starting from the vehicle front left wheel, then repeat the procedure in the order of the front right wheel, rear right wheel, and rear left wheel.

4. Check that the turn signal lamps blink twice when the tire pressure sensor wake-up procedure for all wheels is completed.
5. Check that the low tire pressure warning lamp turns OFF, after the tire pressure sensor wake-up procedure is completed for all wheels and turns OFF.

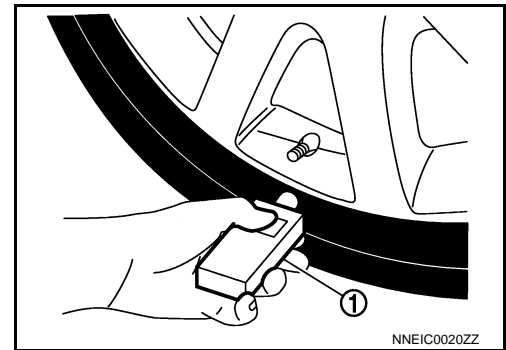

NNEIC0020ZZ

Is the tire pressure sensor wake-up procedure completed?

- YES >> Perform the tire pressure sensor ID registration procedure. Refer to [WT-7, "Work Procedure"](#).
 NO >> Perform trouble diagnosis for the tire pressure sensor. Refer to [WT-16, "Diagnosis Procedure"](#).

ID REGISTRATION

< BASIC INSPECTION >

ID REGISTRATION

Description

INFOID:000000008279675

This procedure must be done after replacing or rotating wheels, replacing tire pressure sensor or BCM.

Work Procedure

INFOID:000000008279676

1. TIRE PRESSURE SENSOR ID REGISTRATION PROCEDURE

CAUTION:

To perform ID registration, observe the following points:

- Never register ID in a place where radio waves are interfered (e.g. radio tower).
- Never register ID in a place close to vehicles including TPMS.

Ⓜ With CONSULT

1. Display the "WORK SUPPORT" screen and select "ID REGIST".

Is the activation tool (J-45295) used for the tire pressure sensor ID registration procedure?

- YES >> GO TO 2.
NO >> GO TO 3.

2. TIRE PRESSURE SENSOR ID REGISTRATION PROCEDURE (WITH THE ACTIVATION TOOL)

1. Turn the ignition switch ON.
2. Select the start button on the "ID REGIST" screen.
3. Contact the activation tool (J-45295) (1) to the side of the tire at the location to the tire pressure sensor.
4. Press and hold the activation tool button while pushing the tool to the tire surface. (approximately for 5 seconds)

CAUTION:

Perform the ID registration procedure starting from the vehicle front left wheel, then repeat the procedure in the order of the front right wheel, rear right wheel, and rear left wheel.

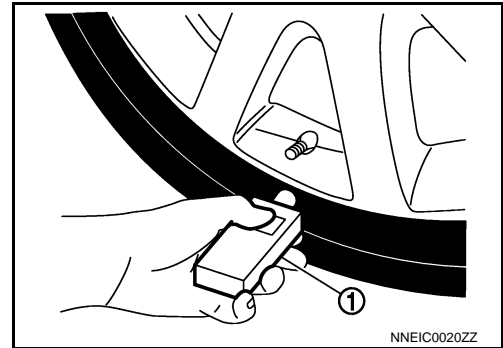

5. When ID registration is completed, check the following pattern at each wheel.

Se-quence	ID registration position	Turn signal lamp	CONSULT
1	Front left wheel	2 blinks	"Red" ↓ "Green"
2	Front right wheel		
3	Rear right wheel		
4	Rear left wheel		

6. After the ID registration procedure for all wheels is completed, press "END" to end ID registration, and check that ID registration for all wheels is completed.

Is the check result normal?

- YES >> ID registration END.
NO >> Refer to [WT-36. "Diagnosis Procedure"](#).

3. TIRE PRESSURE SENSOR ID REGISTRATION PROCEDURE (WITHOUT THE ACTIVATION TOOL)

1. Adjust the tire pressure for all wheels to match the list below.

Tire position	Tire pressure kPa (kg/cm ² , psi)
Front LH	240 (2.4, 35)
Front RH	220 (2.2, 31)

A
B
C
D
WT
F
G
H
I
J
K
L
M
N
O
P

ID REGISTRATION

< BASIC INSPECTION >

Tire position	Tire pressure kPa (kg/cm ² , psi)
Rear RH	200 (2.0, 29)
Rear LH	180 (1.8, 26)

2. Drive the vehicle at a speed at more than 40 km/h (25 MPH) for 3 minutes or more, then perform the tire pressure sensor ID registration procedure.
3. After ID registration for all wheels is completed, press "END" to end ID registration.

ID registration position	CONSULT
Front LH	"Red" ↓ "Green"
Front RH	
Rear RH	
Rear LH	

4. Adjust the tire pressures for all wheels to the specified value. Refer to [WT-50, "Tire Air Pressure"](#).

Is ID registrations for all wheels completed?

YES >> ID registration END.

NO >> Perform "SELF-DIAG RESULTS" of "AIR PRESSURE MONITOR" in "BCM". Refer to [BCS-61, "DTC Index"](#).

SYSTEM

< SYSTEM DESCRIPTION >

SYSTEM DESCRIPTION

SYSTEM

System Diagram

INFOID:000000008279677

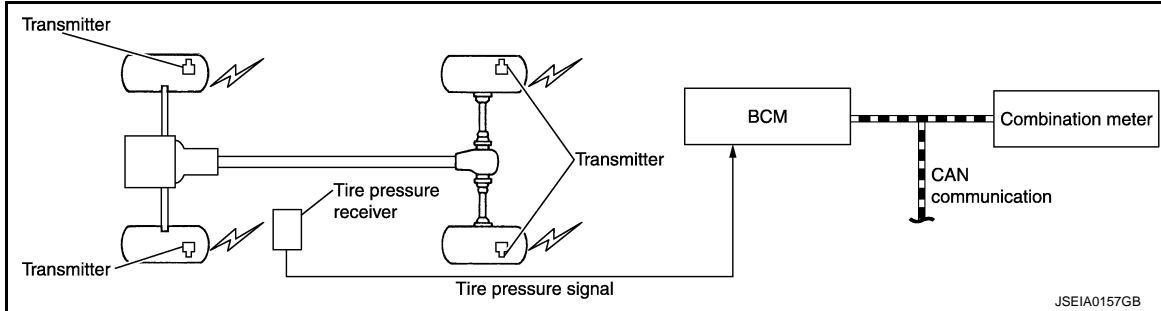

System Description

INFOID:000000008279678

DISCRIPTION

During driving, the TPMS (Tire Pressure Monitoring System) receives the signal transmitted from tire pressure sensor installed in each wheel, when the tire pressure becomes low. The BCM (Body Control Module) of this system has pressure judgment and trouble diagnosis functions. When the tire pressure monitoring system detects low inflation pressure or another unusual symptom, the low tire pressure warning lamps in the combination meter comes on.

INPUT/OUTPUT SIGNAL

The signal transmission/reception between units via a communication line is mainly as listed in the following table.

Component parts	Signal item
BCM	Transmits the following signals via CAN communication to the combination meter. <ul style="list-style-type: none"> • Low tire pressure warning lamp signal • TPMS malfunction warning lamp signal

TIRE PRESSURE SENSOR

The tire pressure sensor (1) integrated with a valve is installed on a wheel (2), and transmits a detected air pressure signal by radio wave.

↔ : Outside

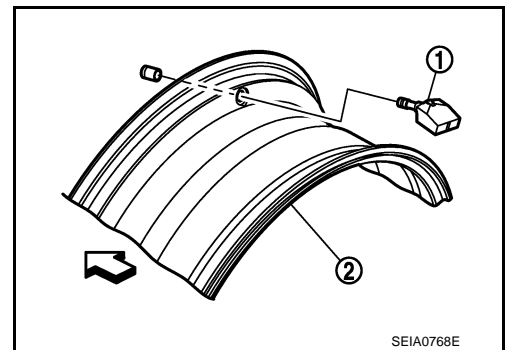

REMOTE KEYLESS ENTRY RECEIVER (TIRE PRESSURE RECEIVER)

SYSTEM

< SYSTEM DESCRIPTION >

The remote keyless entry receiver (tire pressure receiver) (1) receives the air pressure signal transmitted by the tire pressure sensor in each wheel.

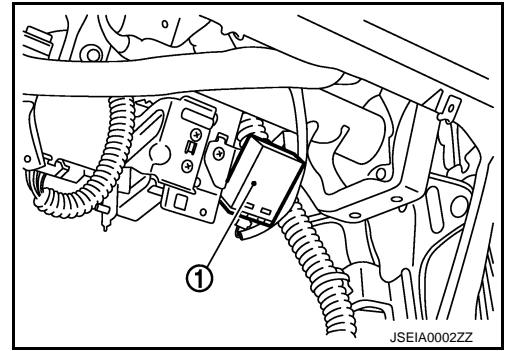

BCM (BODY CONTROL MODULE)

The BCM (1) reads the air pressure signal received by the remote keyless entry receiver (tire pressure receiver), and controls the low tire pressure warning lamp and the buzzer operations. It also has a judgment function to detect a system malfunction.

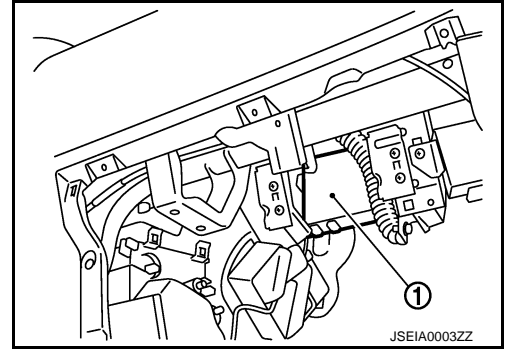

LOW TIRE PRESSURE WARNING LAMP

The combination meter receives tire pressure status from the BCM using CAN communication. When BCM judges from a tire pressure sensor signal that tire pressure is insufficient, BCM transmits a signal to combination meter through CAN communication. combination meter turns on the low tire pressure warning lamp mounted on the combination meter.

Condition	Low tire pressure warning lamp
Ignition switch OFF	OFF
Ignition switch ON (system normal)	Warning lamp turns on for 1second, then turns off.
Low tire pressure	ON
Tire pressure sensor ID not registered in BCM	
Tire pressure monitoring system malfunction (Other diagnostic item)	Warning lamp blinks 1 min, then turns on.

SYSTEM

< SYSTEM DESCRIPTION >

Component Parts Location

INFOID:000000008279679

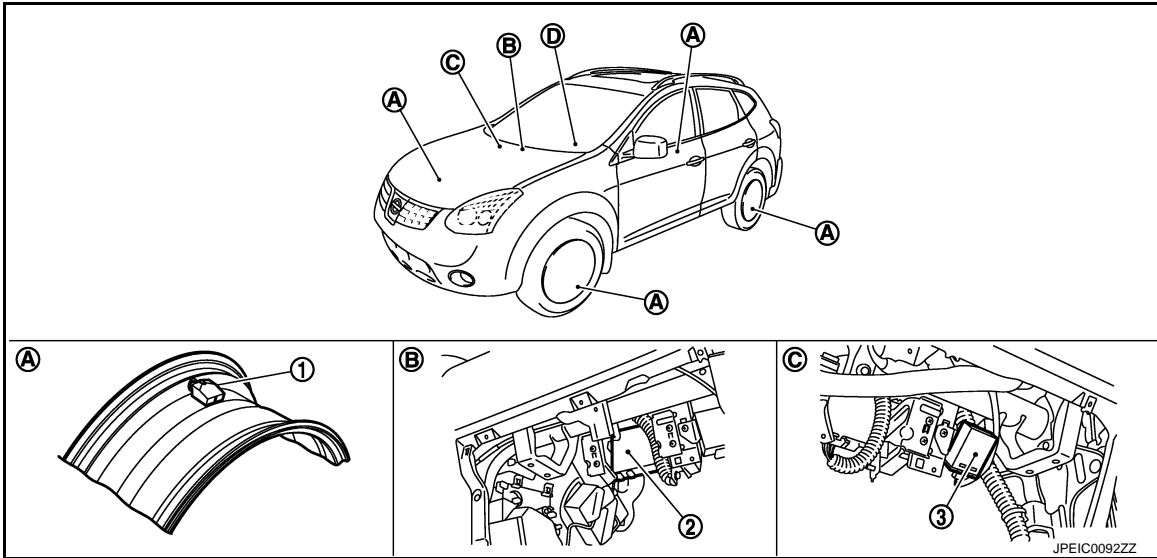

1. Tire pressure sensor

2. BCM

3. Remote keyless entry receiver
(Tire pressure receiver)

A. Wheel

B. Behind glove box cover assembly

C. Behind glove box cover assembly

D. Low tire pressure warning lamp (in
combination meter)

Component Description

INFOID:000000008279680

Component parts	Function
BCM (Body Control Module)	BCS-7, "System Description" .
Tire pressure sensor	WT-19, "Description" .
Remote keyless entry receiver (Tire pressure receiver)	WT-23, "Description" .
Turn signal lamp	ID registration of each wheel has been completed, turn signal lamp flashes.
Combination meter	Controls a low tire pressure warning lamp, turn signal lamp, and buzzer by signals from the BCM.
Low tire pressure warning lamp	WT-25, "Description" l.

DIAGNOSIS SYSTEM (BCM)

< SYSTEM DESCRIPTION >

DIAGNOSIS SYSTEM (BCM)

COMMON ITEM

COMMON ITEM : CONSULT Function (BCM - COMMON ITEM)

INFOID:000000008279681

APPLICATION ITEM

CONSULT can display each diagnostic item using the diagnostic test modes shown following.

Diagnosis mode	Function description
ECU Identification	BCM part number is displayed.
Self-Diagnostic Result	Displays the diagnosis results judged by BCM. Refer to BCS-61, "DTC Index" .
Data Monitor	BCM input/output signals are displayed.
Active Test	The signals used to activate each device are forcibly supplied from BCM.
Work Support	Changes the setting for each system function.
Configuration	<ul style="list-style-type: none"> Read and save the vehicle specification. Write the vehicle specification when replacing BCM.
CAN Diag Support Monitor	Monitors the reception status of CAN communication viewed from BCM.

SYSTEM APPLICATION

BCM can perform the following functions for each system.

NOTE:

It can perform the diagnosis modes except the following for all sub system selection items.

×: Applicable item

System	CONSULT sub system selection item	Diagnosis mode		
		Work Support	Data Monitor	Active Test
Door lock	DOOR LOCK	×	×	×
Rear window defogger	REAR DEFOGGER		×	×
Warning chime	BUZZER		×	×
Interior room lamp control	INT LAMP	×	×	×
Remote keyless entry system	MULTI REMOTE ENT	×	×	×
Exterior lamp	HEAD LAMP	×	×	×
Wiper and washer	WIPER	×	×	×
Turn signal and hazard warning lamps	FLASHER		×	×
<ul style="list-style-type: none"> Auto air conditioning system Manual air conditioning system 	AIR CONDITONER		×	
Intelligent Key system	INTELLIGENT KEY		×	
Combination switch	COMB SW		×	
Body control system	BCM	×		
Immobilizer	IMMU		×	×
Interior room lamp battery saver	BATTERY SAVER	×	×	×
Back door open	TRUNK		×	×
Vehicle security system	THEFT ALM	×	×	×
RAP system	RETAINED PWR	×	×	×
Signal buffer system	SIGNAL BUFFER		×	×
—	FUEL LID*			
TPMS	AIR PRESSURE MONITOR	×	×	×
Panic alarm system	PANIC ALARM			×

*: This item is displayed, but is not function.

AIR PRESSURE MONITOR

DIAGNOSIS SYSTEM (BCM)

< SYSTEM DESCRIPTION >

AIR PRESSURE MONITOR : CONSULT Function (BCM - AIR PRESSURE MONITOR)

INFOID:000000008279682

WORK SUPPORT MODE

ID Read

The registered ID number is displayed.

ID Regist

Refer to [WT-7, "Work Procedure"](#).

SELF-DIAG RESULTS MODE

Operation Procedure

Refer to [BCS-61, "DTC Index"](#).

DATA MONITOR MODE

Screen of data monitor mode is displayed.

NOTE:

When malfunction is detected, CONSULT perform REAL-TIME DIAGNOSIS.

Also, any malfunction detected while in this mode will be displayed at real time.

The following table includes information (items) inapplicable to this vehicle. For information (items) applicable to this vehicle, refer to CONSULT display items.

Display item list

Monitor	Condition	Specification
VEHICLE SPEED	Drive vehicle	Vehicle speed (km/h or MPH)
AIR PRESS FL AIR PRESS FR AIR PRESS RR AIR PRESS RL	<ul style="list-style-type: none"> Drive vehicle for a few minutes. or Ignition switch ON and tire pressure sensor activation tool is transmitting activation signals. 	Tire pressure (kPa, kg/cm ² or Psi)
ID REGST FL ID REGST FR ID REGST RR ID REGST RL	Ignition switch ON	Registration ID: Done No registration: Yet
WARNING LAMP		Low tire pressure warning lamp ON: On Low tire pressure warning lamp OFF: Off
BUZZER		Buzzer in combination meter ON: On Buzzer in combination meter OFF: Off

NOTE:

Before performing the self-diagnosis, be sure to register the ID, or erase the actual malfunction location may be different from that displayed on CONSULT.

ACTIVE TEST MODE

NOTE:

Before performing the self-diagnosis, be sure to register the ID, or erase the actual malfunction may be different from that displayed on CONSULT.

TEST ITEM LIST

Test item	Content
WARNING LAMP	This test is able to check to check that the low tire pressure warning lamp turns on.
ID REGIST WARNING	This test is able to check to check that the buzzer sounds or the low tire pressure warning lamp turns on.
FLAT TIRE WARNING	This test is able to check to check that the buzzer sounds.
HORN	This test is able to check to check that the horn sounds.
FLASHER	This test is able to check to check that each turn signal lamp turns on.
RUNFLAT TIRE W/L	NOTE: This item is displayed, but cannot be use this item.

C1704, C1705, C1706, C1707 LOW TIRE PRESSURE

< DTC/CIRCUIT DIAGNOSIS >

DTC/CIRCUIT DIAGNOSIS

C1704, C1705, C1706, C1707 LOW TIRE PRESSURE

Description

INFOID:000000008279683

When the tire pressure monitoring system detects low inflation pressure, the low tire pressure warning lamps in the combination meter comes on.

DTC Logic

INFOID:000000008279684

DTC DETECTION LOGIC

DTC	Display item	Malfunction detected condition	Possible cause
C1704	LOW PRESSURE FL	Front LH tire pressure drops to * kPa (* kg/cm ² , * psi) or less. [NOTE]	• Low tire pressure • tire pressure sensor malfunction
C1705	LOW PRESSURE FR	Front RH tire pressure drops to * kPa (* kg/cm ² , * psi) or less. [NOTE]	
C1706	LOW PRESSURE RR	Rear RH tire pressure drops to * kPa (* kg/cm ² , * psi) or less. [NOTE]	
C1707	LOW PRESSURE RL	Rear LH tire pressure drops to * kPa (* kg/cm ² , * psi) or less. [NOTE]	

NOTE:

- 182.7 kPa (1.9 kg/cm², 26 psi): Standard air pressure is for 230 kPa (2.3 kg/cm², 26 psi) vehicles.
- 205.1 kPa (2.1 kg/cm², 30 psi): Standard air pressure is for 260 kPa (2.6 kg/cm², 38 psi) vehicles.

DTC CONFIRMATION PROCEDURE

1. DTC REPRODUCTION PROCEDURE

Ⓢ With CONSULT

1. Turn the ignition switch ON.

CAUTION:

Never start the engine.

2. Check the tire pressure for all wheels and adjust to the specified value. Refer to [WT-50, "Tire Air Pressure"](#).
3. Perform "SELF-DIAG RESULTS" in "AIR PRESSURE MONITOR" of "BCM".

Is DTC "C1704", "C1705", "C1706", "C1707" detected?

- YES >> Perform trouble diagnosis. Refer to [WT-14, "Diagnosis Procedure"](#).
NO >> INSPECTION END

Diagnosis Procedure

INFOID:000000008279685

1. CHECK TIRE PRESSURE

Check the internal pressure of all wheels. Refer to [WT-50, "Tire Air Pressure"](#).

Is the inspection result normal?

- YES >> Replace the DTC-detected malfunctioning tire pressure sensor. Refer to [WT-46, "Exploded View"](#).
NO >> After adjusting the air pressure, GO TO 2.

2. CHECK TIRE PRESSURE SIGNAL

Ⓢ With CONSULT

1. Drive for 3 minutes at a speed of 40 km/h (25 MPH) or more, then drive normally for 10 minutes.
2. Perform "DATA MONITOR" in "AIR PRESSURE MONITOR" of "BCM".
3. Select "BCM" in "DATA MONITOR", and check that the tire pressures match the standard value.

C1704, C1705, C1706, C1707 LOW TIRE PRESSURE

< DTC/CIRCUIT DIAGNOSIS >

Monitor item	Condition	Displayed value
AIR PRESS FL	Drive for 3 minutes at a speed of 40 km/h (25 MPH) or more, then drive normally for 10 minutes.	Internal pressure of tires
AIR PRESS FR		
AIR PRESS RR		
AIR PRESS RL		

CAUTION:

Stop the vehicle and within 5 minutes, use “DATA MONITOR” in “AIR PRESSURE MONITOR” of “BCM” to display the tire pressure for all wheels.

Is the inspection result normal?

- YES >> Inspect or repair the tires or wheels and adjust the tire pressure to the specification.
- NO >> GO TO 1.

A
B
C
D
E
F
G
H
I
J
K
L
M
N
O
P

WT

C1708, C1709, C1710, C1711 TIRE PRESSURE SENSOR

< DTC/CIRCUIT DIAGNOSIS >

C1708, C1709, C1710, C1711 TIRE PRESSURE SENSOR

DTC Logic

INFOID:000000008279686

DTC DETECTION LOGIC

DTC	Display item	Malfunction detected condition	Possible cause
C1708	[NO DATA] FL	Tire pressure data signal from the front left wheel tire pressure sensor cannot be detected.	<ul style="list-style-type: none"> • Harness or connector (Tire pressure receiver, BCM) • ID registration is not finished • Tire pressure sensor malfunction • BCM malfunction
C1709	[NO DATA] FR	Tire pressure data signal from the front right wheel tire pressure sensor cannot be detected.	
C1710	[NO DATA] RR	Tire pressure data signal from the rear right wheel tire pressure sensor cannot be detected.	
C1711	[NO DATA] RL	Tire pressure data signal from the rear left wheel tire pressure sensor cannot be detected.	

DTC CONFIRMATION PROCEDURE

1. DTC REPRODUCTION PROCEDURE

Ⓜ With CONSULT

1. Drive for 3 minutes at a speed of 40 km/h (25 MPH) or more, then drive normally for 10 minutes.
2. Perform "SELF-DIAG RESULTS" in "AIR PRESSURE MONITOR" of "BCM".

Is DTC "C1708", "C1709", "C1710", "C1711" detected?

- YES >> Perform trouble diagnosis. Refer to [WT-16, "Diagnosis Procedure"](#).
 NO >> INSPECTION END

Diagnosis Procedure

INFOID:000000008279687

1. CHECK TIRE PRESSURE SIGNAL

Ⓜ With CONSULT

1. Drive for 3 minutes at a speed of 40 km/h (25 MPH) or more, then drive normally for 10 minutes.
2. Perform "DATA MONITOR" in "AIR PRESSURE MONITOR" of "BCM".
3. Select "BCM" in "DATA MONITOR", and check that the tire pressures match the standard value.

Monitor item	Condition	Displayed value
AIR PRESS FL	Drive for 3 minutes at a speed of 40 km/h (25 MPH) or more, then drive normally for 10 minutes.	Internal pressure of tires
AIR PRESS FR		
AIR PRESS RR		
AIR PRESS RL		

CAUTION:

Stop the vehicle and within 5 minutes, use "DATA MONITOR" in "AIR PRESSURE MONITOR" of "BCM" to display the tire pressure for all wheels.

Is a tire pressure of 0 kPa (0 kg/cm², 0 Psi) displayed for all wheels?

- YES >> GO TO 2.
 NO >> GO TO 5.

2. CHECK HARNESS BETWEEN BCM AND REMOTE KEYLESS ENTRY RECEIVER (TIRE PRESSURE RECEIVER)

1. Turn the ignition switch OFF.
2. Disconnect BCM harness connector and remote keyless entry receiver (tire pressure receiver) harness connector.
3. Check the continuity between BCM harness connector and remote keyless entry receiver (tire pressure receiver) harness connector.

C1708, C1709, C1710, C1711 TIRE PRESSURE SENSOR

< DTC/CIRCUIT DIAGNOSIS >

BCM		Remote keyless entry receiver (Tire pressure receiver)		Continuity
Connector	Terminal	Connector	Terminal	
M65	18	M91	1	Existed
	19		4	
	20		2	

4. Check the continuity between BCM harness connector and ground.

BCM		—	Continuity
Connector	Terminal		
M65	18	Ground	Not existed
	19		
	20		

Is the inspection result normal?

YES >> GO TO 3.

NO >> Repair or replace damaged parts.

3. CHECK REMOTE KEYLESS ENTRY RECEIVER (TIRE PRESSURE RECEIVER) POWER SUPPLY CIRCUIT

1. Connect the BCM harness connector.

2. Turn the ignition switch ON.

CAUTION:

Never start the engine.

3. Check the voltage between the BCM harness connector and ground.

BCM		—	Voltage (Approx.)
Connector	Terminal		
M65	18	Ground	5 V

Is the inspection result normal?

YES >> GO TO 4.

NO >> Repair or replace damaged parts.

4. CHECK REMOTE KEYLESS ENTRY RECEIVER (TIRE PRESSURE RECEIVER)

Check remote keyless entry receiver (tire pressure receiver). Refer to [WT-23. "Diagnosis Procedure"](#).

Is the inspection result normal?

YES >> GO TO 5.

NO >> Replace remote keyless entry receiver (tire pressure receiver). Refer to [WT-49. "Removal and Installation"](#).

5. CHECK ID REGISTRATION

Perform ID registration of all tire pressure sensors. Refer to [WT-7. "Work Procedure"](#).

Can ID registration of all tire pressure sensors be completed?

YES >> GO TO 6.

NO >> Replace tire pressure sensor. Refer to [WT-46. "Exploded View"](#).

6. CHECK TIRE PRESSURE MONITORING SYSTEM

Ⓜ With CONSULT

1. Drive at a speed of 40 km/h (25 MPH) or more for several minutes without stopping.

2. Perform "DATA MONITOR" in "AIR PRESSURE MONITOR" of "BCM".

3. Select "BCM" in "DATA MONITOR", and check that the tire pressures match the standard value.

C1708, C1709, C1710, C1711 TIRE PRESSURE SENSOR

< DTC/CIRCUIT DIAGNOSIS >

Monitor item	Condition	Displayed value
AIR PRESS FL	Drive at a speed of 40 km/h (25 MPH) or more, for several minutes without stopping.	Internal pressure of tires
AIR PRESS FR		
AIR PRESS RR		
AIR PRESS RL		

CAUTION:

Stop the vehicle and within 15 minutes, use “DATA MONITOR” in “AIR PRESSURE MONITOR” of “BCM” to read the tire pressure for all wheels.

Is the inspection result normal?

- YES >> Replace the DTC-detected malfunctioning tire pressure sensor. Refer to [WT-46. "Exploded View"](#).
NO >> Replace BCM. Refer to [BCS-65. "Exploded View"](#).

C1716, C1717, C1718, C1719 TIRE PRESSURE SENSOR

< DTC/CIRCUIT DIAGNOSIS >

C1716, C1717, C1718, C1719 TIRE PRESSURE SENSOR

Description

INFOID:000000008279688

The tire pressure sensor integrated with a valve is installed on a wheel, and transmits a detected tire pressure signal by radio wave.

DTC Logic

INFOID:000000008279689

DTC DETECTION LOGIC

DTC	Display item	Malfunction detected condition	Possible case
C1716	[PRESSDATA ERR] FL	Malfunction in the tire pressure data from the front left wheel tire pressure sensor.	<ul style="list-style-type: none">• ID registration is not finished• Tire pressure sensor malfunction
C1717	[PRESSDATA ERR] FR	Malfunction in the tire pressure data from the front right wheel tire pressure sensor.	
C1718	[PRESSDATA ERR] RR	Malfunction in the tire pressure data from the rear right wheel tire pressure sensor.	
C1719	[PRESSDATA ERR] RL	Malfunction in the tire pressure data from the rear left wheel tire pressure sensor.	

DTC CONFIRMATION PROCEDURE

1. DTC REPRODUCTION PROCEDURE

④ With CONSULT

1. Turn the ignition switch ON.

CAUTION:

Never start the engine.

2. Check the tire pressure for all wheels and adjust to the specified value. Refer to [WT-50, "Tire Air Pressure"](#).
3. Perform "SELF-DIAG RESULTS" in "AIR PRESSURE MONITOR" of "BCM".

Is DTC "C1716", "C1717", "C1718", "C1719" detected?

YES >> Perform trouble diagnosis. Refer to [WT-19, "Diagnosis Procedure"](#).

NO >> INSPECTION END

Diagnosis Procedure

INFOID:000000008279690

1. CHECK TIRE PRESSURE

Check the internal pressure of all wheels. Refer to [WT-50, "Tire Air Pressure"](#).

Is the inspection result normal?

YES >> Replace the DTC-detected malfunctioning tire pressure sensor. Refer to [WT-46, "Exploded View"](#).

NO >> After adjusting the tire pressure, GO TO 2.

2. CHECK TIRE PRESSURE SIGNAL

④ With CONSULT

1. Check and adjust the tire pressure for all wheels. Refer to [WT-50, "Tire Air Pressure"](#).
2. Perform tire pressure sensor ID registration for all wheels. Refer to [WT-7, "Work Procedure"](#).
3. Drive for 3 minutes at a speed of 40 km/h (25 MPH) or more, then drive normally for 10 minutes.
4. Perform "DATA MONITOR" in "AIR PRESSURE MONITOR" of "BCM".
5. Select "BCM" in "DATA MONITOR", and check that the tire pressures match the standard value.

CAUTION:

Stop the vehicle and within 15 minutes, use "DATA MONITOR" in "AIR PRESSURE MONITOR" of "BCM" to read the tire pressure for all wheels.

6. Check that "DATA MONITOR" displays tire pressure of 438.60 kPa (4.47 kg/cm², 63.60 Psi).

Is the inspection 438.60 kPa (4.47 kg/cm², 63.60 Psi)?

YES >> Replace tire pressure sensor the tire pressure 438.60 kPa (4.47 kg/cm², 63.60 Psi) displayed. Refer to [WT-46, "Exploded View"](#).

C1716, C1717, C1718, C1719 TIRE PRESSURE SENSOR

< DTC/CIRCUIT DIAGNOSIS >

NO >> GO TO 1.

C1729 VEHICLE SPEED SIGNAL

< DTC/CIRCUIT DIAGNOSIS >

C1729 VEHICLE SPEED SIGNAL

Description

INFOID:000000008279691

BCM detects no vehicle speed signal.

DTC Logic

INFOID:000000008279692

DTC DETECTION LOGIC

DTC	Display item	Malfunction detected condition	Possible case
C1729	VHCL SPEED SIG ERR	Vehicle speed signal not detected.	<ul style="list-style-type: none">CAN communication errorCombination meter malfunction

DTC CONFIRMATION PROCEDURE

1. DTC REPRODUCTION PROCEDURE

④ With CONSULT

- Drive for several minutes at a speed of 40 km/h (25 MPH) or more, then stop the vehicle.
- Perform "SELF-DIAG RESULTS" in "AIR PRESSURE MONITOR" of "BCM".

Is DTC "C1729" detected?

- YES >> Perform trouble diagnosis. Refer to [WT-21, "Diagnosis Procedure"](#).
NO >> INSPECTION END

Diagnosis Procedure

INFOID:000000008279693

1. PERFORM COMBINATION METER SELF-DIAGNOSIS

④ With CONSULT

Perform "SELF-DIAG RESULTS" of "METER/M&A".

Is any DTC detected?

- YES >> Check the DTC. Refer to [MWI-40, "DTC Index"](#).
NO >> GO TO 2.

2. CHECK INFORMATION

④ With CONSULT

- Perform "DATA MONITOR" in "AIR PRESSURE MONITOR" of "BCM".
- Select "BCM" in "DATA MONITOR", and check the input/output values. Refer to [BCS-42, "Reference Value"](#).

Is the inspection result normal?

- YES >> Check pin terminal and connection of each harness connector for malfunctioning conditions.
NO >> Replace BCM. Refer to [BCS-65, "Exploded View"](#).

C1735 IGNITION SIGNAL

< DTC/CIRCUIT DIAGNOSIS >

C1735 IGNITION SIGNAL

Description

INFOID:000000008279694

The BCM monitors the IGN ON signal on the CAN line and compares it to its direct IGN ON signal. When these two signals do not match, the BCM sets C1735.

DTC Logic

INFOID:000000008279695

DTC DETECTION LOGIC

DTC	Display item	Malfunction detected condition	Possible case
C1735	IGNITION SIGNAL LINE - BCM/TPMS	BCM has detected a mismatch between IGN ON signals.	<ul style="list-style-type: none">• CAN communication error• BCM malfunction

DTC CONFIRMATION PROCEDURE

1.CHECK SELF-DIAGNOSTIC RESULTS

Perform "SELF-DIAG RESULTS" in "AIR PRESSURE MONITOR" of "BCM".

Is DTC "C1735" detected?

- YES >> Perform trouble diagnosis. Refer to [WT-22, "Diagnosis Procedure"](#).
- NO >> INSPECTION END

Diagnosis Procedure

INFOID:000000008279696

1.CHECK IGNITION SIGNAL

ⓂWith CONSULT

1. Perform "DATA MONITOR" of "BCM".
2. Select "BCM" in "DATA MONITOR", and check the "IGN SW CAN". Refer to [BCS-42, "Reference Value"](#).

Is the inspection result normal?

- YES >> GO TO 2.
- NO >> Perform CAN diagnosis. Refer to [LAN-26, "CAN System Specification Chart"](#).

2.CHECK POWER SUPPLY CIRCUIT

Check BCM power supply circuit. Refer to [WT-26, "Diagnosis Procedure"](#).

Is the inspection result normal?

- YES >> GO TO 3.
- NO >> Repair or replace damaged parts.

3.CHECK SELF-DIAGNOSTIC RESULTS

ⓂWith CONSULT

1. Drive for 3 minutes at a speed of 40 km/h (25 MPH) or more, then drive normally for 10 minutes.
2. Perform "SELF-DIAG RESULTS" in "AIR PRESSURE MONITOR" of "BCM".

Is DTC "C1735" detected?

- YES >> Replace BCM. Refer to [BCS-65, "Exploded View"](#).
- NO >> INSPECTION END

REMOTE KEYLESS ENTRY RECEIVER

< DTC/CIRCUIT DIAGNOSIS >

REMOTE KEYLESS ENTRY RECEIVER

Description

INFOID:000000008279697

The remote keyless entry receiver (tire pressure receiver) receives the air pressure signal transmitted by the tire pressure sensor in each wheel.

Component Function Check

INFOID:000000008279698

1. TIRE PRESSURE MONITORING SYSTEM OPERATION

Ⓜ With CONSULT

1. Drive for 3 minutes at a speed of 40 km/h (25 MPH) or more, then drive normally for 10 minutes.
2. Perform "DATA MONITOR" in "AIR PRESSURE MONITOR" of "BCM".
3. Select "BCM" in "DATA MONITOR", and check that the tire pressures match the standard value.

Monitor item	Condition	Displayed value
AIR PRESS FL	Drive for 3 minutes at a speed of 40 km/h (25 MPH) or more, then drive normally for 10 minutes.	Internal pressure of tires
AIR PRESS FR		
AIR PRESS RR		
AIR PRESS RL		

CAUTION:

Stop the vehicle and within 5 minutes, use "DATA MONITOR" in "AIR PRESSURE MONITOR" of "BCM" to display the tire pressure for all wheels.

Is the inspection result normal?

YES >> INSPECTION END

NO >> Perform trouble diagnosis. Refer to [WT-23. "Diagnosis Procedure"](#).

Diagnosis Procedure

INFOID:000000008279699

1. CHECK REMOTE KEYLESS ENTRY RECEIVER (TIRE PRESSURE RECEIVER) SIGNAL

1. Turn the ignition switch ON.

CAUTION:

Never start the engine.

2. Check remote keyless entry receiver (tire pressure receiver) connector and ground signal with oscilloscope.

Remote keyless entry receiver (Tire pressure receiver)		—	Condition	Voltage (Approx.)
Connector	Terminal			
M91	2	Ground	Stand by state	<p>OCC3881D</p>
			When receiving the signal from the tire pressure sensor	<p>OCC3880D</p>

Is the inspection result normal?

REMOTE KEYLESS ENTRY RECEIVER

< DTC/CIRCUIT DIAGNOSIS >

- YES >> INSPECTION END
NO >> GO TO 2.

2. CHECK REMOTE KEYLESS ENTRY RECEIVER (TIRE PRESSURE RECEIVER) INPUT VOLTAGE

1. Disconnect remote keyless entry receiver (tire pressure receiver) connector.
2. Check voltage between remote keyless entry receiver (tire pressure receiver) connector and ground.

Remote keyless entry receiver (Tire pressure receiver)		—	Voltage (Approx.)
Connector	Terminal		
M91	4	Ground	5.0 V

Is the inspection result normal?

- YES >> GO TO 3.
NO >> Repair or replace damaged parts.

3. CHECK REMOTE KEYLESS ENTRY RECEIVER (TIRE PRESSURE RECEIVER) GROUND CIRCUIT

1. Disconnect BCM harness connector.
2. Check continuity between BCM harness connector and remote keyless entry receiver (tire pressure receiver) connector.

BCM		Remote keyless entry receiver (Tire pressure receiver)		Continuity
Connector	Terminal	Connector	Terminal	
M65	18	M91	1	Existed

3. Check continuity between BCM harness connector and ground.

BCM		—	Continuity
Connector	Terminal		
M65	18	Ground	Not existed

Is the inspection result normal?

- YES >> GO TO 4.
NO >> Repair or replace damaged parts.

4. CHECK BCM CIRCUIT

Inspect the BCM circuit. Refer to [WT-26. "Diagnosis Procedure"](#).

Is the BCM circuit normal?

- YES >> Replace remote keyless entry receiver (tire pressure receiver). Refer to [WT-49. "Removal and Installation"](#).
NO >> Replace BCM. Refer to [BCS-65. "Exploded View"](#).

LOW TIRE PRESSURE WARNING LAMP

< DTC/CIRCUIT DIAGNOSIS >

LOW TIRE PRESSURE WARNING LAMP

Description

INFOID:000000008279700

The combination meter receives tire pressure status from the BCM using CAN communication. When BCM judges from a tire pressure sensor signal that tire pressure is insufficient, BCM transmits a signal to combination meter through CAN communication. combination meter turns on the low tire pressure warning lamp mounted on the combination meter.

Condition	Low tire pressure warning lamp
Ignition switch OFF	OFF
Ignition switch ON (system normal)	Warning lamp turns on for 1second, then turns off.
Low tire pressure	ON
Tire pressure sensor ID not registered in BCM	
Tire pressure monitoring system malfunction (Other diagnostic item)	Warning lamp blinks 1 min, then turns on.

Component Function Check

INFOID:000000008279701

1. CHECK THE ILLUMINATION OF THE LOW TIRE PRESSURE WARNING LAMP

Check that the low tire pressure warning lamp is turned OFF after illuminating for approximately 1 second, when the ignition switch is turned ON.

Is the inspection result normal?

YES >> INSPECTION END

NO >> Perform trouble diagnosis. Refer to [WT-25, "Diagnosis Procedure"](#).

Diagnosis Procedure

INFOID:000000008279702

1. POWER SUPPLY AND GROUND CIRCUIT

Check power supply and ground circuit. Refer to [WT-26, "Diagnosis Procedure"](#).

Is the inspection result normal?

YES >> GO TO 2.

NO >> Repair or replace damaged parts.

2. PERFORM SELF-DIAGNOSIS

 With CONSULT

Perform "SELF-DIAG RESULTS" in "AIR PRESSURE MONITOR" of "BCM".

Is any DTC detected?

YES >> Check the DTC. Refer to [BCS-61, "DTC Index"](#).

NO >> GO TO 3.

3. CHECK LOW TIRE PRESSURE WARNING LAMP SIGNAL

 With CONSULT

1. Turn the ignition switch ON.

CAUTION:

Never start the engine.

2. Perform "DATA MONITOR" in "AIR PRESSURE MONITOR" of "BCM".

3. Select "BCM" in "DATA MONITOR", and check that the low tire pressure warning lamp is turned OFF after illuminating for approximately 1 second, when the ignition switch is turned ON.

Is the inspection result normal?

YES >> Check the combination meter. Refer to [MWI-8, "METER SYSTEM : System Description"](#).

NO >> Replace the BCM. Refer to [BCS-65, "Exploded View"](#).

POWER SUPPLY AND GROUND CIRCUIT

< DTC/CIRCUIT DIAGNOSIS >

POWER SUPPLY AND GROUND CIRCUIT

Diagnosis Procedure

INFOID:000000008279703

1. POWER SUPPLY SYSTEM CHECK

1. Turn the ignition switch OFF.
2. Disconnect the BCM harness connector.
3. Turn the ignition switch ON.
CAUTION:
Never start the engine.
4. Check the voltage between the BCM harness connector and the ground.

BCM		—	Voltage
Connector	Terminal		
M67	57	Ground	Battery voltage
	70		

Is the inspection result normal?

- YES >> GO TO 2.
NO >> Repair or replace damaged parts.

2. GROUND SYSTEM INSPECTION

1. Turn the ignition switch OFF.
2. Check the continuity between the BCM harness connector and the ground.

BCM		—	Continuity
Connector	Terminal		
M67	67	Ground	Existed

Is the inspection result normal?

- YES >> • Check the 10 A fuse [No. 10 in fuse block (J/B)].
• Check the 50 A fusible link [No. J in fuse block].
NO >> Repair or replace damaged parts.

BCM

< ECU DIAGNOSIS INFORMATION >

ECU DIAGNOSIS INFORMATION

BCM

List of ECU Reference

INFOID:000000008279704

ECU	Reference
	BCS-42, "Reference Value"
BCM	BCS-60, "Fail-safe"
	BCS-61, "DTC Inspection Priority Chart"
	BCS-61, "DTC Index"

A

B

C

D

WT

F

G

H

I

J

K

L

M

N

O

P

TIRE PRESSURE MONITORING SYSTEM

< WIRING DIAGRAM >

WIRING DIAGRAM

TIRE PRESSURE MONITORING SYSTEM

Wiring Diagram

INFOID:000000008752351

For connector terminal arrangements, harness layouts, and alphabets in a  (option abbreviation; if not described in wiring diagram), refer to [GI-12. "Connector Information"](#).

TIRE PRESSURE MONITORING SYSTEM

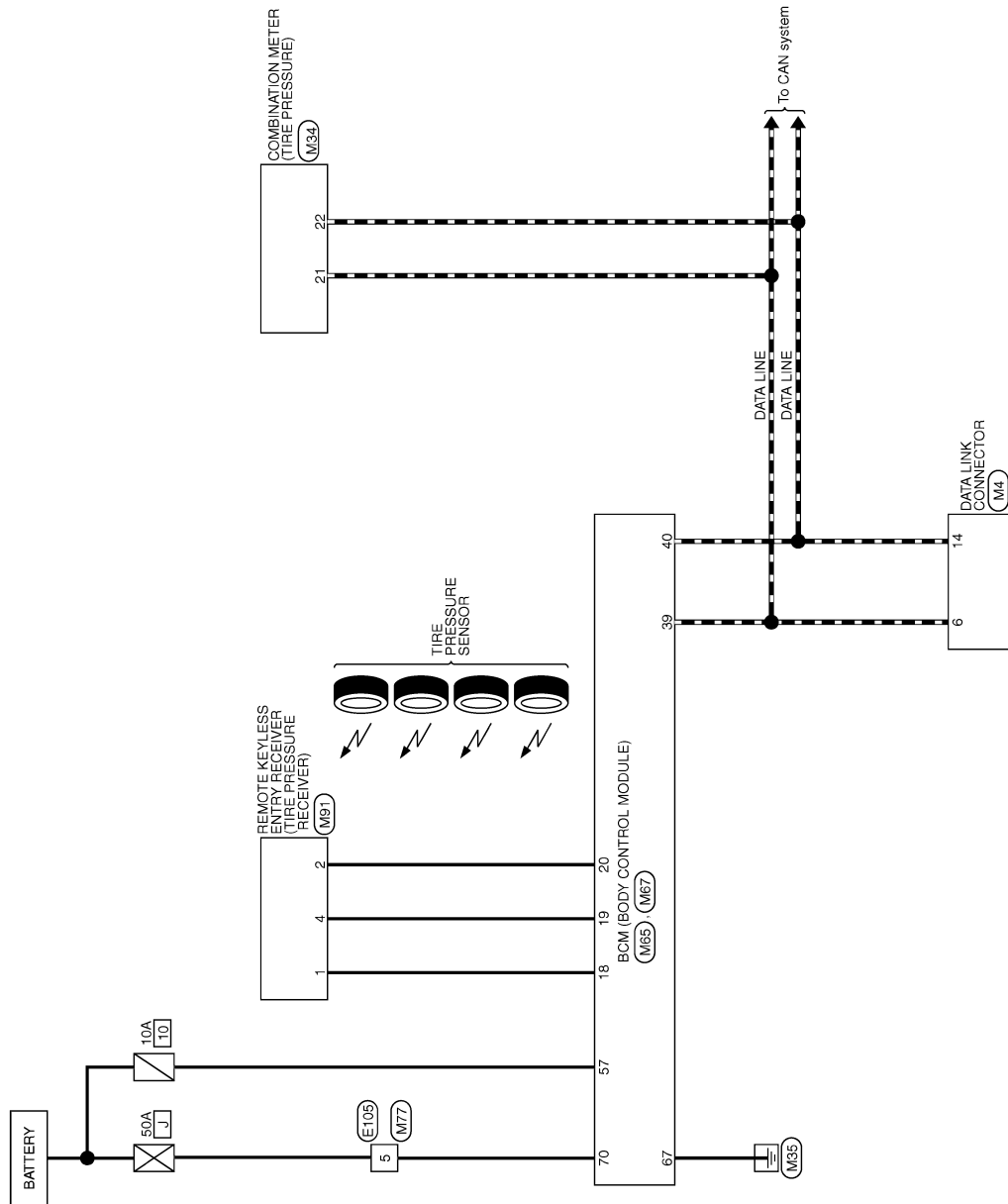

2012/05/23

JREW0097GB

< SYMPTOM DIAGNOSIS >

SYMPTOM DIAGNOSIS

TPMS

Symptom Table

INFOID:000000008279706

LOW TIRE PRESSURE WARNING LAMP SYMPTOM CHART

A

B

C

D

WT

F

G

H

I

J

K

L

M















N

O

P

TPMS

< SYMPTOM DIAGNOSIS >

Diagnosis items	Symptom (Ignition switch ON)	Low tire pressure warning lamp	Cause	Action
Low tire pressure warning lamp	The low tire pressure warning lamp illuminates for 1 second, then turns OFF.	  ON 1 sec > stays OFF <small>SEIA0592E</small>	Wake-up operation for all tire pressure sensors at wheels is completed.	No system malfunctions
	The low tire pressure warning lamp repeats blinking ON for 2 seconds and OFF for 0.2 seconds.	 Blinks:  ON 2 sec > OFF 0.2 sec <small>SEIA0593E</small>	Wake-up operation for all tire pressure sensors at wheels is not completed.	Perform the wake-up operation for all tire pressure sensors at wheels. Refer to WT-6, "Work Procedure" .
	The low tire pressure warning lamp blinks once.	 Blinks 1 time ON 0.3 sec > OFF 1.0 sec <small>JPEIC0090GB</small>	The front left tire pressure sensor is not activated.	Perform the wake-up operation for the tire pressure sensor at front left wheel. Refer to WT-6, "Work Procedure" .
	The low tire pressure warning lamp repeats blinking twice.	  Blinks 2 times ON 0.3 sec > OFF 0.3 sec <small>SEIA0595E</small>	The front right tire pressure sensor is not activated.	Perform the wake-up operation for the tire pressure sensor at front right wheel. Refer to WT-6, "Work Procedure" .
	The low tire pressure warning lamp repeats blinking for 3 times.	   Blinks 3 times ON 0.3 sec > OFF 0.3 sec <small>SEIA0596E</small>	The rear right tire pressure sensor is not activated.	Perform the wake-up operation for the tire pressure sensor at rear right wheel. Refer to WT-6, "Work Procedure" .
	The low tire pressure warning lamp repeats blinking for 4 times.	    Blinks 4 times ON 0.3 sec > OFF 0.3 sec <small>SEIA0597E</small>	The rear left tire pressure sensor is not activated.	Perform the wake-up operation for the tire pressure sensor at rear left wheel. Refer to WT-6, "Work Procedure" .
	The low tire pressure warning lamp turns ON and stays illuminated.	 Comes ON and stays ON <small>SEIA0598E</small>	Low tire pressure	Check the tire pressure for all wheels and adjust to the specified value. Refer to WT-50, "Tire Air Pressure" .

TPMS

< SYMPTOM DIAGNOSIS >

Diagnosis items	Symptom (Ignition switch ON)	Low tire pressure warning lamp	Cause	Action
Low tire pressure warning lamp	The low tire pressure warning lamp repeats blinking at 0.5-second intervals for 1 minute, and then stays illuminated.	 <p style="text-align: center;">Blinks 1 min</p> <p style="text-align: center;">ON 0.5 sec > OFF 0.5 sec and stays ON</p> <p style="text-align: center;"><small>SEIA0788E</small></p>	The combination meter fuse is open or removed (or pulled out).	Check and install the combination meter fuse. If necessary, replace the fuse.
			The BCM harness connector is removed.	Check the connection conditions of the BCM harness connector, and repair if necessary.
			Tire Pressure Monitoring System (TPMS) malfunction.	<ul style="list-style-type: none"> Perform CONSULT self-diagnosis. Refer to WT-12, "COMMON ITEM : CONSULT Function (BCM - COMMON ITEM)". If necessary, perform tire pressure sensor ID registration. Refer to WT-7, "Work Procedure".
Turn signal lamp	The turn signal lamps do not blink twice when the tire pressure sensor is activated. Or the buzzer does not sound.	—	<ol style="list-style-type: none"> The activation tool (J-45295) does not activate. The ignition switch is OFF when the tire pressure sensor wake-up operation is performed. The activation tool (J-45295) is not used in the correct position. The tire pressure sensor is already waked up. 	<ol style="list-style-type: none"> Replace the battery in the activation tool (J-45295). Turn the ignition switch ON when performing the tire pressure sensor wake-up operation. Operate the activation tool (J-45295) in the correct position when performing the wake-up operation. No procedure.

NOTE:

If tire pressure sensor wake-up operation is not completed for two or more tire pressure sensors, the applicable low tire pressure warning lamp blinking patterns are displayed continuously.
 (Example: Blinks once/OFF/blinks 3 times = Wake-up operation is not completed at the front left wheel and rear right wheel tire pressure sensors.)

A
B
C
D
WT
F
G
H
I
J
K
L
M
N
O
P

LOW TIRE PRESSURE WARNING LAMP DOES NOT TURN ON

< SYMPTOM DIAGNOSIS >

LOW TIRE PRESSURE WARNING LAMP DOES NOT TURN ON

Description

INFOID:000000008279707

DESCRIPTION

The low tire pressure warning lamp illuminates for approximately 1 second and then turns OFF when the ignition switch is turned ON. This is to check that no abnormal condition is present in the tire pressure monitoring system.

The lamp bulb may be burnt out or the tire pressure monitoring system may be malfunctioning if the low tire pressure warning lamp does not illuminate when the ignition switch is turned ON.

Diagnosis Procedure

INFOID:000000008279708

1.CHECK SELF-DIAGNOSIS RESULTS

Ⓜ With CONSULT

Perform "SELF-DIAG RESULTS" in "AIR PRESSURE MONITOR" of "BCM".

Is "CAN COMM CIRCUIT" displayed in the self-diagnosis display items?

YES >> Perform trouble diagnosis for CAN communication system. Refer to [LAN-26, "CAN System Specification Chart"](#).

NO >> GO TO 2.

2.CHECK COMBINATION METER

Check combination meter function. Refer to [MWI-27, "CONSULT Function"](#).

Is the inspection result normal?

YES >> GO TO 3.

NO >> Repair or replace damaged parts.

3.CHECK LOW TIRE PRESSURE WARNING LAMP

1. Turn the ignition switch "OFF".
2. Disconnect BCM harness connectors.
3. Turn ignition switch "ON". (Never start engine.)

Does low tire pressure warning lamp turn on?

YES >> GO TO 4.

NO >> Check combination meter and repair or replace. Refer to [MWI-8, "METER SYSTEM : System Description"](#).

4.CHECK SYMPTOM

Check again.

Is the inspection result normal?

YES >> INSPECTION END

NO >> GO TO 5.

5.CHECK BCM

Check BCM input/output signal. Refer to [BCS-42, "Reference Value"](#).

Is the inspection result normal?

YES >> GO TO 4.

NO >> GO TO 6.

6.CHECK BCM HARNESS CONNECTOR

Check BCM pin terminals for damage or loose connection with harness connector.

Is the inspection result normal?

YES >> Replace BCM. Refer to [BCS-65, "Exploded View"](#).

NO >> Repair or replace damaged parts.

LOW TIRE PRESSURE WARNING LAMP DOES NOT TURN OFF

< SYMPTOM DIAGNOSIS >

LOW TIRE PRESSURE WARNING LAMP DOES NOT TURN OFF

Description

INFOID:000000008279709

DESCRIPTION

The tire pressure monitoring system is checked and the warning lamp is illuminated for approximately 1 second when the ignition switch is turned ON. The low tire pressure warning lamp turns OFF after the system check finishes.

The system may be malfunctioning if the low tire pressure warning lamp does not turn off approximately 1 second after the ignition switch is turned ON.

Diagnosis Procedure

INFOID:000000008279710

1. CHECK TIRE PRESSURE

1. Turn the ignition switch ON.

CAUTION:

Never start the engine.

2. Check the tire pressure for all wheels and adjust to the specified value. Refer to [WT-50, "Tire Air Pressure"](#).

Is the inspection result normal?

YES >> GO TO 2.

NO >> Inspect or repair the tires or wheels.

2. CHECK LOW TIRE PRESSURE WARNING LAMP

Check low tire pressure warning lamp display.

Does not low tire pressure warning lamp turn OFF?

YES >> GO TO 3.

NO >> INSPECTION END

3. CHECK SYSTEM FOR BCM

 With CONSULT

Perform "SELF-DIAG RESULTS" in "AIR PRESSURE MONITOR" of "BCM".

Is any DTC detected?

YES >> Perform trouble diagnosis. Refer to [BCS-61, "DTC Index"](#).

NO >> GO TO 4.

4. CHECK ID REGISTRATION

Perform ID registration all tire pressure sensors. Refer to [WT-7, "Work Procedure"](#).

Does low tire pressure warning lamp turn OFF?

YES >> INSPECTION END

NO >> GO TO 5.

5. CHECK POWER SUPPLY CIRCUIT

1. Turn the ignition switch "OFF".
2. Disconnect BCM harness connector.
3. Check voltage between BCM and harness connector terminals and ground.

BCM		—	Voltage (Approx.)
Connector	Terminal		
M67	57	Ground	Battery voltage
	70		

Is the power supply normal?

YES >> GO TO 6.

NO >> Check the following. If any items are damaged, repair or replace damage parts.

- 50 A fusible link [No. J located in the fuse block]. Refer to [PG-98, "Fuse and Fusible Link Arrangement"](#).

LOW TIRE PRESSURE WARNING LAMP DOES NOT TURN OFF

< SYMPTOM DIAGNOSIS >

- 10 A fuse [No.10 located in the fuse block (J/B)]. Refer to [PG-97. "Fuse, Connector and Terminal Arrangement"](#).
- Harness for short or open between battery and BCM harness connector M67 terminal 57.
- Harness for short or open between battery and BCM harness connector M67 terminal 70.
- Check battery voltage.

6.CHECK GROUND CIRCUIT

1. Turn the ignition switch "OFF".
2. Disconnect BCM harness connector.
3. Check continuity between BCM harness connector M67 terminal 67 and ground.

BCM		—	Continuity
Connector	Terminal		
M67	67	Ground	Existed

Also check harness for short to power.

Is the inspection result normal?

- YES >> GO TO 7.
NO >> Repair open circuit or short to power in harness or connectors.

7.CHECK SYMPTOM

Check again.

Is the inspection result normal?

- YES >> INSPECTION END
NO >> GO TO 8.

8.CHECK BCM

Check BCM input/output signal. Refer to [BCS-42. "Reference Value"](#).

Is the inspection result normal?

- YES >> GO TO 7.
NO >> GO TO 9.

9.CHECK BCM HARNESS CONNECTOR

Check BCM pin terminals for damage or loose connection with harness connector.

Is the inspection result normal?

- YES >> Replace BCM. Refer to [BCS-65. "Exploded View"](#).
NO >> Repair or replace damaged parts.

LOW TIRE PRESSURE WARNING LAMP BLINKS

< SYMPTOM DIAGNOSIS >

LOW TIRE PRESSURE WARNING LAMP BLINKS

Description

INFOID:000000008279711

The low tire pressure warning lamp blinks when the ignition switch is turned ON.

NOTE:

The position of an inactive tire pressure sensor can be identified by checking the blinking timing of the low tire pressure warning lamp.

Low tire pressure warning lamp blinking timing		Activation tire position
ON OFF		a : 0.3 sec. b : 1.0 sec. Front LH
ON OFF		a : 0.3 sec. b : 1.0 sec. Front RH
ON OFF		a : 0.3 sec. b : 1.0 sec. Rear RH
ON OFF		a : 0.3 sec. b : 1.0 sec. Rear LH
ON OFF		a : 2 sec. b : 0.2 sec. All tires

JPEIC0089GB

Diagnosis Procedure

INFOID:000000008279712

1. CHECK TIRE PRESSURE SENSOR WAKE-UP OPERATION

Perform the tire pressure sensor wake-up. Refer to [WT-6, "Work Procedure"](#).

Is the tire pressure sensor wake-up completed?

YES >> GO TO 2.

NO >> Perform trouble diagnosis for the tire pressure sensor. Refer to [WT-16, "Diagnosis Procedure"](#).

2. CHECK TIRE PRESSURE SENSOR ID REGISTRATION

Perform tire pressure sensor ID registration. Refer to [WT-7, "Work Procedure"](#).

Is tire pressure sensor ID registration completed?

YES >> INSPECTION END

NO >> Perform "SELF-DIAG RESULTS" "AIR PRESSURE MONITOR" "BCM". Refer to [BCS-61, "DTC Index"](#).

ID REGISTRATION CANNOT BE COMPLETED

< SYMPTOM DIAGNOSIS >

ID REGISTRATION CANNOT BE COMPLETED

Description

INFOID:000000008279713

DESCRIPTION

The ID of the tire pressure sensor installed in each wheel cannot be registered in the tire pressure monitoring system.

Inspect the tire pressure sensor or the tire pressure monitoring system circuit.

Diagnosis Procedure

INFOID:000000008279714

1. CHECK ACTIVATION TOOL

Check activation tool.

Is the inspection result normal?

YES >> GO TO 2.

NO >> Replace battery for activation tool, or repair or replace activation tool.

2. TIRE PRESSURE SENSOR ID REGISTRATION

Perform tire pressure sensor ID registration. Refer to [WT-7, "Work Procedure"](#).

CAUTION:

To perform ID registration, observe the following points:

- Never register ID in a place where radio waves are interfered (e.g. radio tower).
- Never register ID in a place close to vehicles including TPMS.

Is tire pressure sensor ID registration completed?

YES >> INSPECTION END

NO >> GO TO 3.

3. CHECK TIRE PRESSURE SIGNAL

Change the work location and perform ID registration again.

NOTE:

Depending on the tire pressure sensor position*, a blind spot exists, and the tire pressure receiver gets a poor reception. If an ID registration is performed under this condition, the registration may not be completed.

In such case, follow the instructions below to improve the radio wave receiving environment.

- Rotate tire by 90°, 180°, or 270°. (This Step is to change tire pressure sensor position.)
- Open the door close to the tire of which ID registration is ongoing.

*: Radio wave reception condition depends on vehicle architecture (e.g. body harness layout, tire wheel design) or environment.

When ID registration is performed, which wheels do not react?

All wheels react and ID registration is possible.>>INSPECTION END

Only certain wheel(s) do not react.>>Replace applicable tire pressure sensor. Refer to [WT-46, "Removal and Installation"](#).

All wheels do not react.>>Check the tire pressure receiver (Remote keyless entry receiver). Refer to [WT-23, "Component Function Check"](#).

NOISE, VIBRATION AND HARSHNESS (NVH) TROUBLESHOOTING

< SYMPTOM DIAGNOSIS >

NOISE, VIBRATION AND HARSHNESS (NVH) TROUBLESHOOTING

NVH Troubleshooting Chart

INFOID:000000008279715

Use chart below to find the cause of the symptom. If necessary, repair or replace these parts.

Symptom		Possible cause and SUSPECTED PARTS													Reference page				
		Improper installation, looseness	Out-of-round	unbalance	Incorrect tire pressure	Uneven tire wear	Deformation or damage	Non-uniformity	Incorrect tire size	PROPELLER SHAFT	DIFFERENTIAL	FRONT AXLE AND FRONT SUSPENSION	REAR AXLE AND REAR SUSPENSION	TIRES	ROAD WHEELS	DRIVE SHAFT	BRAKE	STEERING	
TIRE	Noise	x	x	x	x	x	x	x		x	x	x	x		x	x	x	x	FSU-9, FSU-6.
	Shake	x	x	x	x	x	x		x	x	x	x		x	x	x	x	x	WT-44, "Inspection"
	Vibration				x				x	x		x	x						WT-41, "Adjustment"
	Shimmy	x	x	x	x	x	x	x	x			x	x		x		x	x	WT-50, "Tire Air Pressure"
	Judder	x	x	x	x	x	x		x			x	x		x		x	x	WT-41, "Adjustment"
	Poor quality ride or handling	x	x	x	x	x	x		x			x		x	x				—
	Noise	x	x	x			x			x	x	x	x	x		x	x	x	—
	Shake	x	x	x			x			x		x	x	x		x	x	x	WT-50, "Tire Air Pressure"
ROAD WHEEL	Shimmy, Judder	x	x	x			x					x	x	x			x	x	NVH in DLN section.
	Poor quality ride or handling	x	x	x			x					x	x	x					NVH in DLN section.
	Noise																		NVH in FAX and FSU sections.
	Shake																		NVH in FAX and FSU sections.
																			Refer to TIRE in this chart.
																			Refer to ROAD WHEEL in this chart.
																			NVH in FAX, RAX section.
																			NVH in BR section.
																			NVH in ST section.

x: Applicable

A
B
C
D
E
F
G
H
I
J
K
L
M
N
O
P

WT

PRECAUTIONS

< PRECAUTION >

PRECAUTION

PRECAUTIONS

FOR USA AND CANADA

FOR USA AND CANADA : Precaution for Supplemental Restraint System (SRS) "AIR BAG" and "SEAT BELT PRE-TENSIONER"

INFOID:000000008279716

The Supplemental Restraint System such as "AIR BAG" and "SEAT BELT PRE-TENSIONER", used along with a front seat belt, helps to reduce the risk or severity of injury to the driver and front passenger for certain types of collision. This system includes seat belt switch inputs and dual stage front air bag modules. The SRS system uses the seat belt switches to determine the front air bag deployment, and may only deploy one front air bag, depending on the severity of a collision and whether the front occupants are belted or unbelted. Information necessary to service the system safely is included in the "SRS AIR BAG" and "SEAT BELT" of this Service Manual.

WARNING:

Always observe the following items for preventing accidental activation.

- **To avoid rendering the SRS inoperative, which could increase the risk of personal injury or death in the event of a collision that would result in air bag inflation, all maintenance must be performed by an authorized NISSAN/INFINITI dealer.**
- **Improper maintenance, including incorrect removal and installation of the SRS, can lead to personal injury caused by unintentional activation of the system. For removal of Spiral Cable and Air Bag Module, see "SRS AIR BAG".**
- **Never use electrical test equipment on any circuit related to the SRS unless instructed to in this Service Manual. SRS wiring harnesses can be identified by yellow and/or orange harnesses or harness connectors.**

PRECAUTIONS WHEN USING POWER TOOLS (AIR OR ELECTRIC) AND HAMMERS

WARNING:

Always observe the following items for preventing accidental activation.

- **When working near the Air Bag Diagnosis Sensor Unit or other Air Bag System sensors with the ignition ON or engine running, never use air or electric power tools or strike near the sensor(s) with a hammer. Heavy vibration could activate the sensor(s) and deploy the air bag(s), possibly causing serious injury.**
- **When using air or electric power tools or hammers, always switch the ignition OFF, disconnect the battery, and wait at least 3 minutes before performing any service.**

FOR USA AND CANADA : Service Notice and Precautions

INFOID:000000008279717

- Low tire pressure warning lamp blinks 1min, then turns ON when occurring any malfunction except low tire pressure. Delete the memory with CONSULT, or register the ID to turn low tire pressure warning lamp OFF. Refer to [WT-7, "Work Procedure"](#).
- ID registration is required when replacing or rotating wheels, replacing tire pressure sensor or BCM. Refer to
- Replace grommet seal, valve core and cap of tire pressure sensor in TPMS every tire replacement by reaching wear limit of tire. Refer to [WT-46, "Exploded View"](#).

FOR MEXICO

FOR MEXICO : Precaution for Supplemental Restraint System (SRS) "AIR BAG" and "SEAT BELT PRE-TENSIONER"

INFOID:000000008279718

The Supplemental Restraint System such as "AIR BAG" and "SEAT BELT PRE-TENSIONER", used along with a front seat belt, helps to reduce the risk or severity of injury to the driver and front passenger for certain types of collision. Information necessary to service the system safely is included in the "SRS AIR BAG" and "SEAT BELT" of this Service Manual.

WARNING:

Always observe the following items for preventing accidental activation.

- **To avoid rendering the SRS inoperative, which could increase the risk of personal injury or death in the event of a collision that would result in air bag inflation, all maintenance must be performed by an authorized NISSAN/INFINITI dealer.**

PRECAUTIONS

< PRECAUTION >

- **Improper maintenance, including incorrect removal and installation of the SRS, can lead to personal injury caused by unintentional activation of the system. For removal of Spiral Cable and Air Bag Module, see “SRS AIR BAG”.**
- **Never use electrical test equipment on any circuit related to the SRS unless instructed to in this Service Manual. SRS wiring harnesses can be identified by yellow and/or orange harnesses or harness connectors.**

PRECAUTIONS WHEN USING POWER TOOLS (AIR OR ELECTRIC) AND HAMMERS

WARNING:

Always observe the following items for preventing accidental activation.

- **When working near the Air Bag Diagnosis Sensor Unit or other Air Bag System sensors with the ignition ON or engine running, never use air or electric power tools or strike near the sensor(s) with a hammer. Heavy vibration could activate the sensor(s) and deploy the air bag(s), possibly causing serious injury.**
- **When using air or electric power tools or hammers, always switch the ignition OFF, disconnect the battery, and wait at least 3 minutes before performing any service.**

FOR MEXICO : Service Notice and Precautions

INFOID:000000008279719

- **Low tire pressure warning lamp blinks 1min, then turns ON when occurring any malfunction except low tire pressure. Delete the memory with CONSULT, or register the ID to turn low tire pressure warning lamp OFF. Refer to [WT-7, "Work Procedure"](#).**
- **ID registration is required when replacing or rotating wheels, replacing tire pressure sensor or BCM. Refer to [WT-46, "Exploded View"](#).**
- **Replace grommet seal, valve core and cap of tire pressure sensor in TPMS every tire replacement by reaching wear limit of tire. Refer to [WT-46, "Exploded View"](#).**

PREPARATION

< PREPARATION >

PREPARATION

PREPARATION

Special Service Tools

INFOID:000000008279720

The actual shapes of Kent-Moore tools may differ from those of special service tools illustrated here.

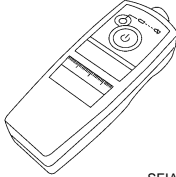
Tool number (Kent-Moore No.) Tool name	Description
– (J-45295) Activation tool  SEIA0462E	Tire pressure sensor wake-up procedure and ID registration

Commercial Service Tools

INFOID:000000008279721

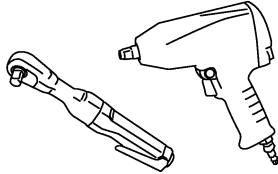
Tool name	Description
Power tool  PBIC0190E	Loosening bolts and nuts

ROAD WHEEL

< PERIODIC MAINTENANCE >

PERIODIC MAINTENANCE

ROAD WHEEL

Adjustment

INFOID:000000008279722

BALANCING WHEELS (ALUMINUM WHEEL)

Preparation Before Adjustment

Using releasing agent, remove double-faced adhesive tape from the road wheel.

CAUTION:

- **Be careful not scratch the road wheel during removal.**
- **After removing double-faced adhesive tape, wipe clean traces of releasing agent from the road wheel.**

Wheel Balance Adjustment

- The details of the adjustment procedure are different for each model of wheel balancer. Therefore, refer to each instruction manual.
- If a tire balance machine has adhesion balance weight mode settings and drive-in weight mode setting, select and adjust a drive-in weight mode suitable for road wheels.

1. Set road wheel on tire balance machine using the center hole as a guide. Start the tire balance machine.
2. When inner and outer unbalance values are shown on the tire balance machine indicator, multiply outer unbalance value by $5/3$ to determine balance weight that should be used. Select the outer balance weight with a value closest to the calculated value above and install in to the designated outer position of, or at the designated angle in relation to the road wheel.

CAUTION:

- **Never install the inner balance weight before installing the outer balance weight.**
- **Before installing the balance weight, be sure to clean the mating surface of the road wheel.**

- a. Indicated unbalance value $\times 5/3 =$ balance weight to be installed

Calculation example:

$23 \text{ g (0.81 oz)} \times 5/3 = 38.33 \text{ g (1.35 oz)} \Rightarrow 40 \text{ g (1.41 oz)}$ balance weight (closer to calculated balance weight value)

NOTE:

Note that balance weight value must be closer to the calculated balance weight value.

Example:

$37.4 \Rightarrow 35 \text{ g (1.23 oz)}$

$37.5 \Rightarrow 40 \text{ g (1.41 oz)}$

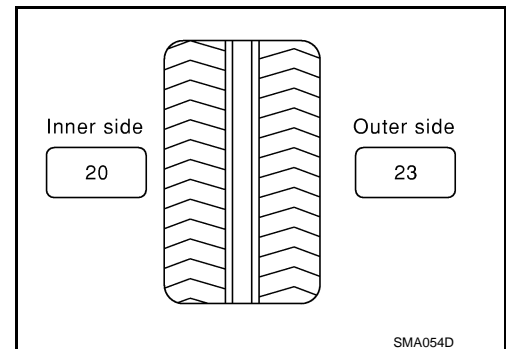

- b. Installed balance weight in the position.

ROAD WHEEL

< PERIODIC MAINTENANCE >

- When installing balance weight (1) to road wheels, set it into the grooved area (A) on the inner wall of the road wheel as shown in the figure so that the balance weight center (B) is aligned with the tire balance machine indication position (angle) (C).

CAUTION:

- Always use genuine NISSAN adhesion balance weights.
- Balance weights are non-reusable; always replace with new ones.
- Never install three or more sheets of balance weight.

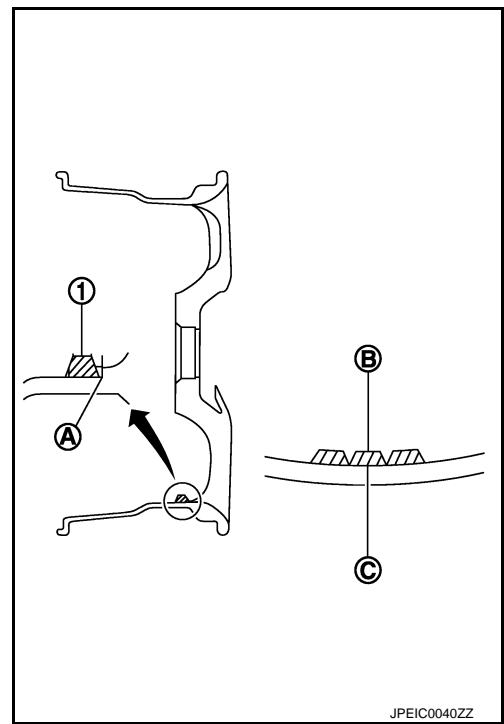

- c. If calculated balance weight value exceeds 50 g (1.76 oz), install two balance weight sheets in line with each other as shown in the figure.

CAUTION:

Never install one balance weight sheet on top of another.

3. Start tire balance machine again.
4. Install drive-in balance weight on inner side of road wheel in the tire balance machine indication position (angle).

CAUTION:

Never install three or more balance weight.

5. Start the tire balance machine. Check that the inner and outer residual unbalance value is within the allowable unbalance value.

CAUTION:

If either residual unbalance value exceeds limit, repeat installation procedures.

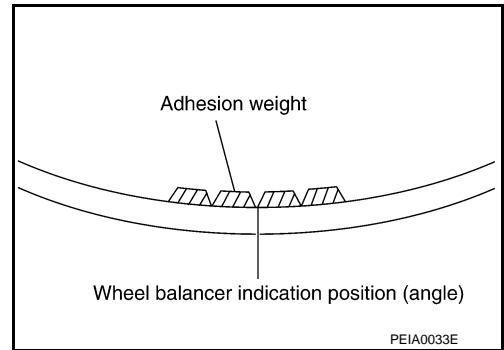

Allowable unbalance value

Dynamic (At flange) : Refer to [WT-50, "Road Wheel"](#).

Static (At flange) : Refer to [WT-50, "Road Wheel"](#).

BALANCING WHEELS (STEEL WHEEL)

Preparation Before Adjustment

Remove balance weight from the road wheel.

CAUTION:

Be careful not to scratch the road wheel during removal.

Wheel Balance Adjustment

- The details of the adjustment procedure are different for each model of wheel balancer. Therefore, refer to each instruction manual.
 - If a tire balance machine has adhesion balance weight mode settings and drive-in weight mode setting, select and adjust a drive-in weight mode suitable for steel wheels.
1. Set road wheel to wheel balancer, and then start wheel balancer.
 2. Install balance weight to road wheel according to the unbalance and position (angle) displayed on wheel balancer.

ROAD WHEEL

< PERIODIC MAINTENANCE >

CAUTION:

- Always use genuine NISSAN balance weights.
- Balance weights are non-reusable; always replace with new ones.
- Always use a plastic hammer when attaching the weight.
- Never install three or more balance weights on one side.

3. Start the tire balance machine. Check that the inner and outer residual unbalance value is within the allowable unbalance value.

CAUTION:

If either residual unbalance value exceeds limit, repeat installation procedures.

Allowable unbalance value

Dynamic (At flange) : Refer to [WT-50, "Road Wheel"](#).

Static (At flange) : Refer to [WT-50, "Road Wheel"](#).

TIRE ROTATION

- Follow the maintenance schedule for tire rotation service intervals. Refer to [MA-9, "FOR NORTH AMERICA : Schedule 1"](#).
- When installing the wheel, tighten wheel nuts to the specified torque. Refer to [WT-44, "Exploded View"](#).

CAUTION:

- Do not include the T-type spare tire when rotating the tires.
 - When installing wheels, tighten them diagonally by dividing the work two to three times in order to prevent the wheels from developing any distortion.
 - Be careful not to tighten wheel nut at torque exceeding the criteria for preventing strain of disc rotor.
 - Use NISSAN genuine wheel nuts for aluminum wheels.
- Perform the ID registration, after tire rotation. Refer to [WT-7, "Work Procedure"](#).

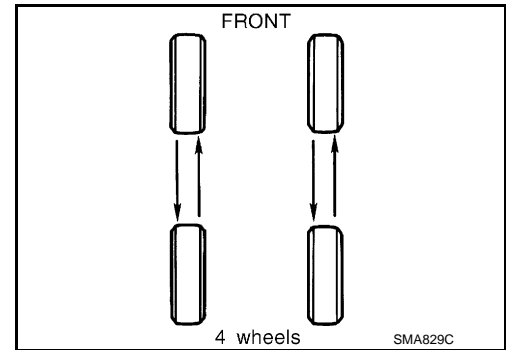

A
B
C
D
WT
F
G
H
I
J
K
L
M
N
O
P

ROAD WHEEL TIRE ASSEMBLY

< REMOVAL AND INSTALLATION >

REMOVAL AND INSTALLATION

ROAD WHEEL TIRE ASSEMBLY

Exploded View

INFOID:000000008279723

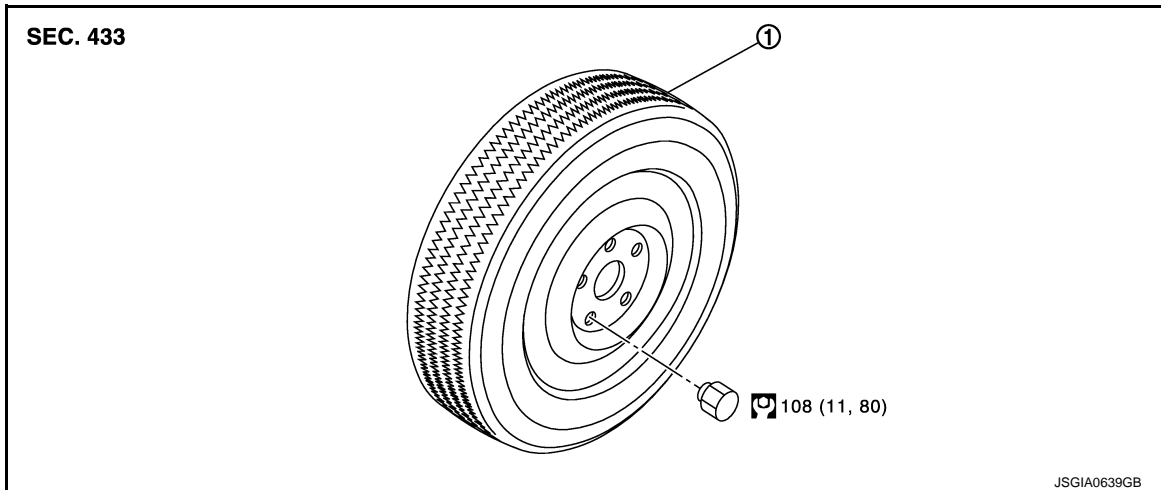

1. Tire assembly

Refer to [GI-4. "Components"](#) for symbols in the figure.

Removal and Installation

INFOID:000000008279724

REMOVAL

1. Remove wheel nuts.
2. Remove tire assembly.

INSTALLATION

Note the following, install in the reverse order of removal.

- When replacing or rotating wheels, perform the ID registration. Refer to [WT-7. "Work Procedure"](#).

Inspection

INFOID:000000008279725

ALUMINUM WHEEL

1. Check tires for wear and improper inflation.
2. Check wheels for deformation, cracks and other damage. If deformed, remove wheel and check wheel runout.
 - a. Remove tire from aluminum wheel and mount on a tire balance machine.
 - b. Set dial indicator as shown in the figure.
 - c. Check runout, if the axial runout (A) or radial runout (B) exceeds the limit, replace aluminum wheel.

Limit

Axial runout (A) : Refer to [WT-50. "Road Wheel"](#).

Radial runout (B) : Refer to [WT-50. "Road Wheel"](#).

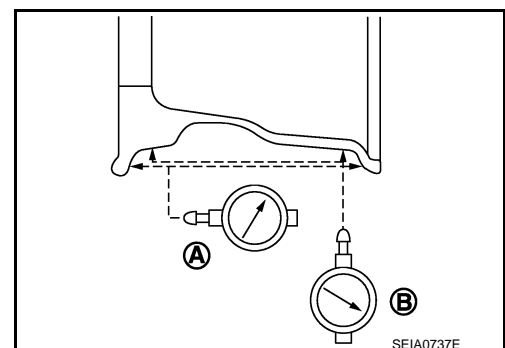

STEEL WHEEL

1. Check tires for wear and improper inflation.

ROAD WHEEL TIRE ASSEMBLY

< REMOVAL AND INSTALLATION >

2. Check wheels for deformation, clacks and other damage. If deformed, remove wheel and check wheel runout.
 - a. Remove tire from steel wheel and mount wheel on a tire balance machine.
 - b. Set two dial indicators as shown in the illustration.
 - c. Set each dial indicator to "0".
 - d. Rotate wheel and check dial indicators at several points around the circumference of the wheel.
 - e. Calculate runout at each point as shown below.

Axial runout (A) : $(1+2)/2$

Radial runout (B) : $(3+4)/2$

- f. Select maximum positive runout value and the maximum negative value. Add the two values to determine total runout.

CAUTION:

In case a positive or negative value is not available, use the maximum value (negative or positive) for total runout.

Limit

A : Refer to [WT-50, "Road Wheel"](#).

B : Refer to [WT-50, "Road Wheel"](#).

- g. If the total runout value exceeds limit, replace steel wheel.

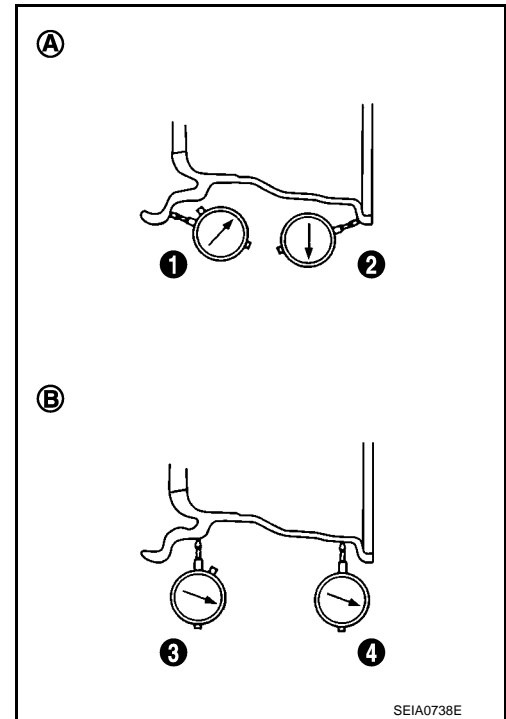

A
B
C
D
WT
F
G
H
I
J
K
L
M
N
O
P

TIRE PRESSURE SENSOR

< REMOVAL AND INSTALLATION >

TIRE PRESSURE SENSOR

Exploded View

INFOID:000000008279726

FOR SCHRADER TYPE

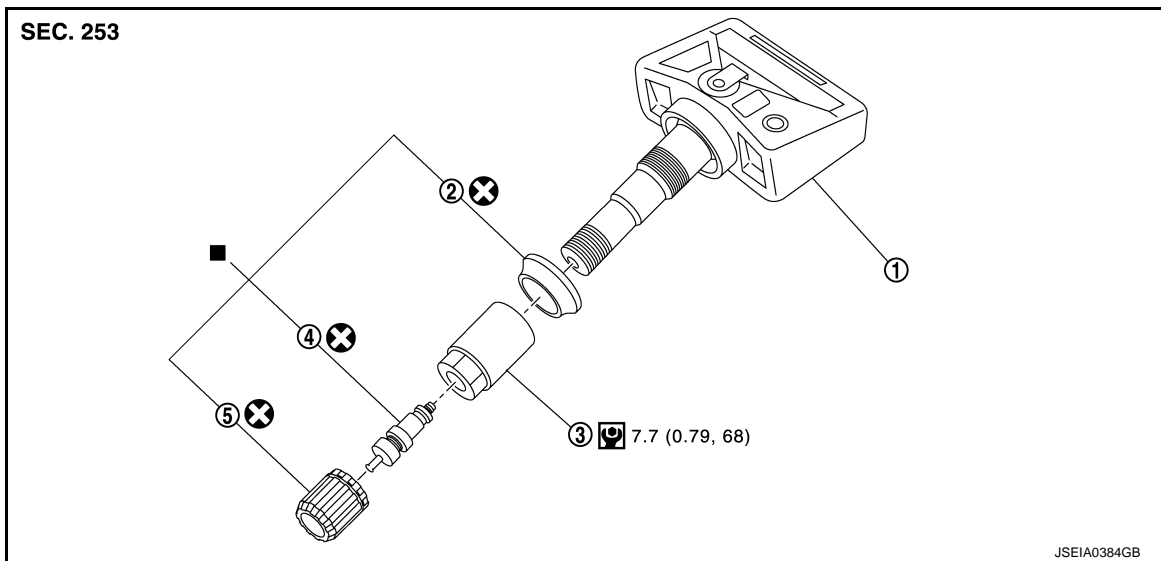

- | | | |
|-------------------------|-----------------|--------------|
| 1. Tire pressure sensor | 2. Grommet seal | 3. Valve nut |
| 4. Valve core | 5. Valve cap | |

■ : Parts that are replaced as a set when the tire is replaced.

Refer to [GI-4, "Components"](#) for symbols not described above.

FOR PACIFIC TYPE

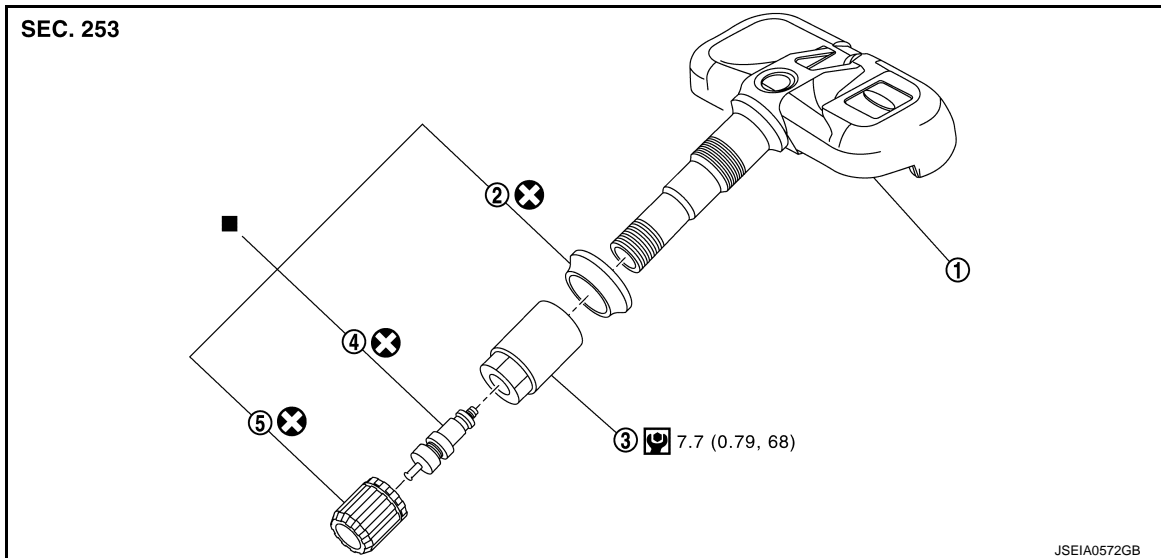

- | | | |
|-------------------------|-----------------|--------------|
| 1. Tire pressure sensor | 2. Grommet seal | 3. Valve nut |
| 4. Valve core | 5. Valve cap | |

■ : Parts that are replaced as a set when the tire is replaced.

Refer to [GI-4, "Components"](#) for symbols not described above.

Removal and Installation

INFOID:000000008279727

REMOVAL

1. Remove tire assembly. Refer to [WT-44, "Removal and Installation"](#).

TIRE PRESSURE SENSOR

< REMOVAL AND INSTALLATION >

- Remove valve cap, valve core and then deflate tire.

NOTE:

If the tire is reused, apply a matching mark to the position of the tire road wheel valve hole for the purpose of wheel balance adjustment after installation.

- Remove valve nut retaining tire pressure sensor and allow tire pressure sensor to fall into tire.
- Use the tire changer and disengage the tire beads.

CAUTION:

- Verify that the tire pressure sensor (1) is at the bottom of the tire while performing the above.
- Be sure not to damage the road wheel or tire pressure sensor.

- Apply bead cream or an equivalent to the tire beads.
- Set tire onto the tire changer turntable so that the tire pressure sensor inside the tire is located close to the road wheel valve hole.

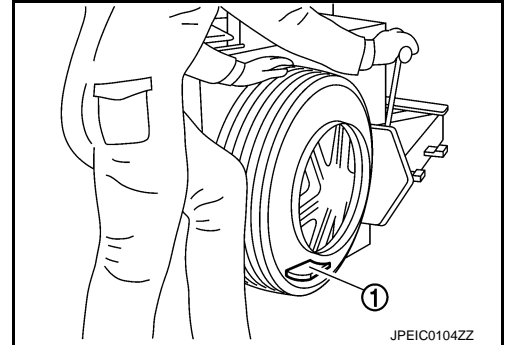

- Turn tire so that valve hole is at bottom and bounce so that tire pressure sensor (1) is near valve hole. Carefully lift tire onto turntable and position valve hole (and tire pressure sensor) 270 degree from mounting/dismounting head (2).

CAUTION:

Be sure not to damage the road wheel and tire pressure sensor.

- Remove tire pressure sensor from tire.
- Remove the grommet seal.

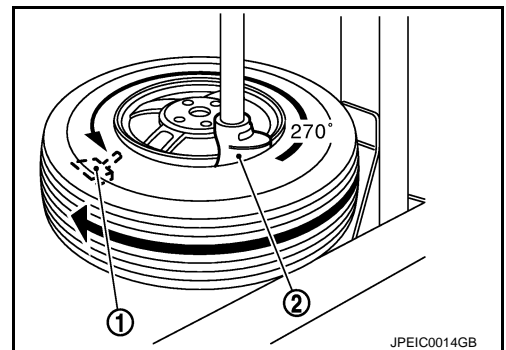

INSTALLATION

- Apply bead cream or an equivalent to the tire beads.
- Install the tire inside beads (1) onto the road wheel (2) in the position shown in the figure.
- Install grommet seal to the tire pressure sensor.

CAUTION:

- Never reuse grommet seal.
- Insert grommet seal all the way to the base.

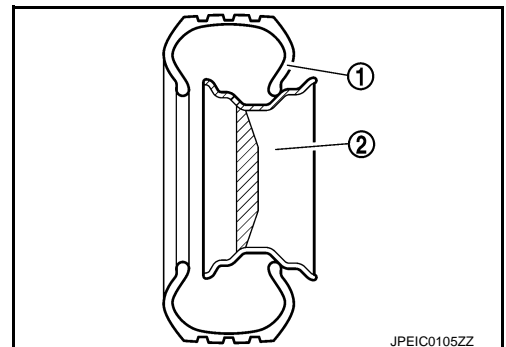

- Hold tire pressure sensor as shown in the figure, and press the sensor in the direction shown by arrow (←) to bring it into absolute contact with valve hole. After this, tighten valve nut to the specified torque.

CAUTION:

- Never reuse valve core and valve cap.
- Check that grommet seal is free of foreign matter.
- Check that grommet seal contacts horizontally with road wheel.
- Manually tighten valve nut all the way to the wheel. (Never use a power tool to avoid impact.)

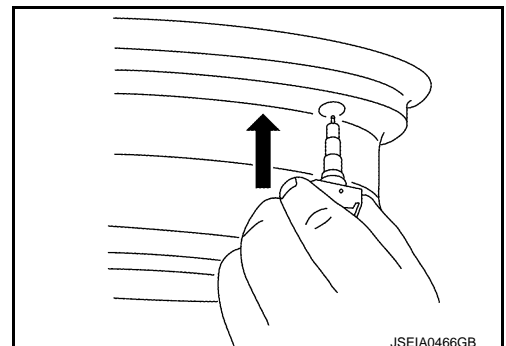

A
B
C
D
WT
F
G
H
I
J
K
L
M
N
O
P

TIRE PRESSURE SENSOR

< REMOVAL AND INSTALLATION >

5. Set the tire onto the turntable so that the tire changer arm (2) is at a position approximately 270° from the tire pressure sensor (1).

CAUTION:

Be sure that the arm does not contact the tire pressure sensor.

6. Install the tire outer side beads onto the road wheel.

CAUTION:

When installing, check that the tire does not turn together with the road wheel.

7. Check the tire pressure for all wheels and adjust to the specified value. Refer to [WT-50, "Tire Air Pressure"](#).

NOTE:

Before adding air, align the tire with the position of the matching mark applied at the time of removal.

8. Install tire to the vehicle. Refer to [WT-44, "Removal and Installation"](#).

9. Perform tire pressure sensor ID registration. Refer to [WT-7, "Work Procedure"](#).

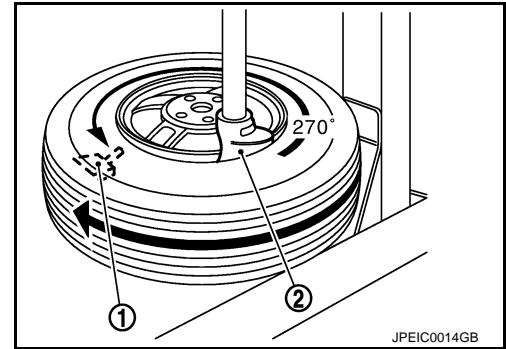

TIRE PRESSURE RECEIVER

< REMOVAL AND INSTALLATION >

TIRE PRESSURE RECEIVER

Removal and Installation

INFOID:000000008279728

REMOVAL

1. Remove the instrument side finisher RH. Refer to [IP-13, "Exploded View"](#).
2. Remove the glove box cover assembly. Refer to [IP-13, "Exploded View"](#).
3. Disconnect tire pressure receiver harness connector.
4. Remove tire pressure receiver.

INSTALLATION

Install is the reverse order of removal.

A

B

C

D

WT

F

G

H

I

J

K

L

M

N

O

P

SERVICE DATA AND SPECIFICATIONS (SDS)

< SERVICE DATA AND SPECIFICATIONS (SDS)

SERVICE DATA AND SPECIFICATIONS (SDS)

SERVICE DATA AND SPECIFICATIONS (SDS)

Road Wheel

INFOID:000000008279729

ALUMINUM WHEEL

Item		Limit
Runout	Axial runout	Less than 0.3 mm (0.012 in)
	Radial runout	
Allowable unbalance	Dynamic (At flange)	Less than 5 g (0.17 oz) (one side)
	Static (At flange)	Less than 10 g (0.35 oz)

STEEL WHEEL

Item		Limit
Runout	Axial runout (Average)	Less than 0.8 mm (0.031 in)
	Radial runout (Average)	Less than 0.5 mm (0.020 in)
Allowable unbalance	Dynamic (At flange)	Less than 5 g (0.17 oz) (one side)
	Static (At flange)	Less than 10 g (0.35 oz)

STEEL WHEEL (EMERGENCY)

Item		Limit
Runout	Axial runout (Average)	Less than 1.2 mm (0.047 in)
	Radial runout (Average)	Less than 1.3 mm (0.051 in)

Tire Air Pressure

INFOID:000000008279730

Unit: kPa (kg/cm², psi)

Tire size	Air pressure	
	Front	Rear
P215/70R16 99H	230 (2.3, 33)	230 (2.3, 33)
P225/60R17 98H	230 (2.3, 33)	230 (2.3, 33)
P225/55R18 97V	2WD	230 (2.3, 33)
	AWD	260 (2.6, 38)
T155/90D16 110M	420 (4.2, 60)	420 (4.2, 60)